

Beckhoff Drive Technology

A primer of linear motors

Last change: 08.11.2001

BECKHOFF

Contents

A primer of linear motors

1. Introduction	4
2. Basic physical principles	5
Principles of magnetism	5
3 Phase Linear Motor AL2000	8
Linear and rotary motors compared	9
3. Positioning	10
The positioning system	10
4. Linear motor system	11
Overview	11
Practical considerations	12
The series AL2000 linear motor	14

1. Introduction

Linear motors (LM) enable linear movements at high speeds with great accuracy. Most linear motors are used in the machine construction industry and for production automation purposes.

In this leaflet the following information can be found:

- The basic physical principles of linear motors.
- The 3 phase linear motor considered.
- A comparison of standard electric (rotary) motors and linear motors.
- The positioning system
- A brief description of a linear motor system and some practical considerations.
- A brief description of series AL2000 linear motor

This leaflet is the first of a series of three, concerning AL2000 series Linear Motors. The series consists of the following titles:

1. A Primer of Linear Motors
2. Designing your Application with AL2000 series Linear Motors
3. Installing AL2000 series Linear Motors

2. Basic physical principles

Principles of magnetism

Attraction and repulsion:

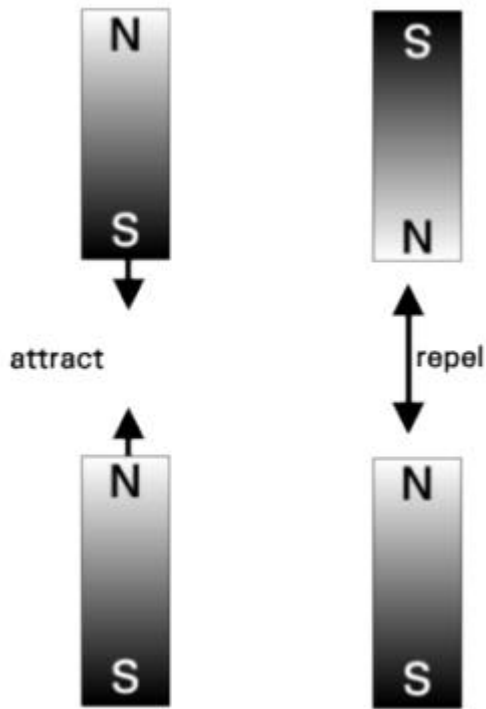

The operation of a linear motor is based on the principles of magnetism. When two permanent magnets are placed in opposition, they will apply a force to each other. Dependent on the position of the poles, they attract or repel each other. Equal poles are repellent and opposite poles are attracting.

Moving principle:

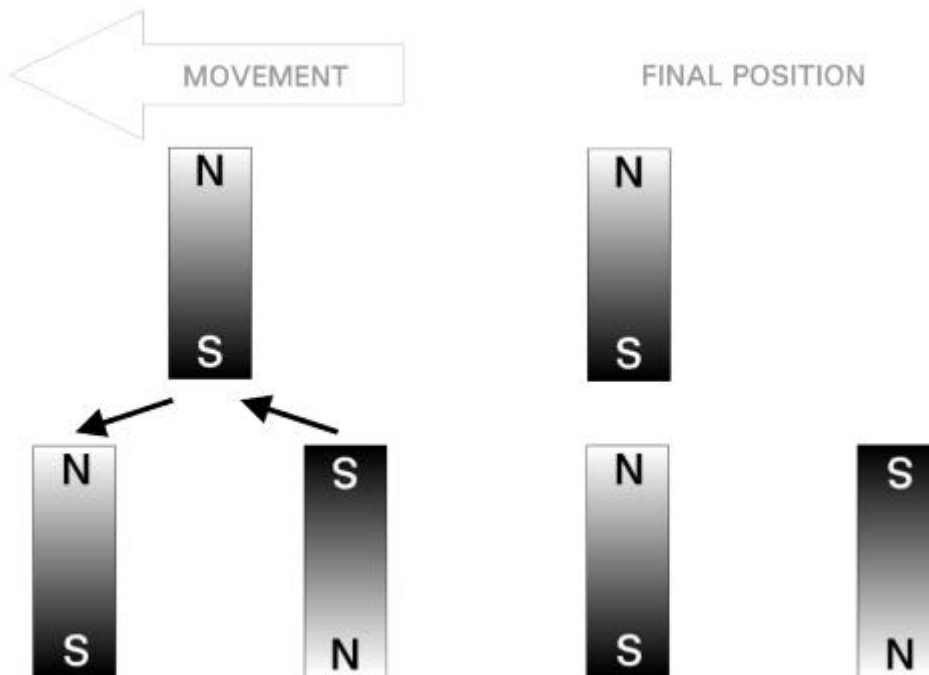

Suppose we have a movable but irrotatable magnet. The magnet only can be moved in a straight horizontal

line. Now this magnet is positioned above two fixed magnets as shown left in the figure. Because of the attracting and repelling forces, it will move towards the magnet with the opposite pole pointing upwards. The movement stops when the magnet is positioned right on top of it. Changing the poles of the upper magnet, would make the magnet move back to the right.

Physical resemblance of permanent magnet and electric coil:

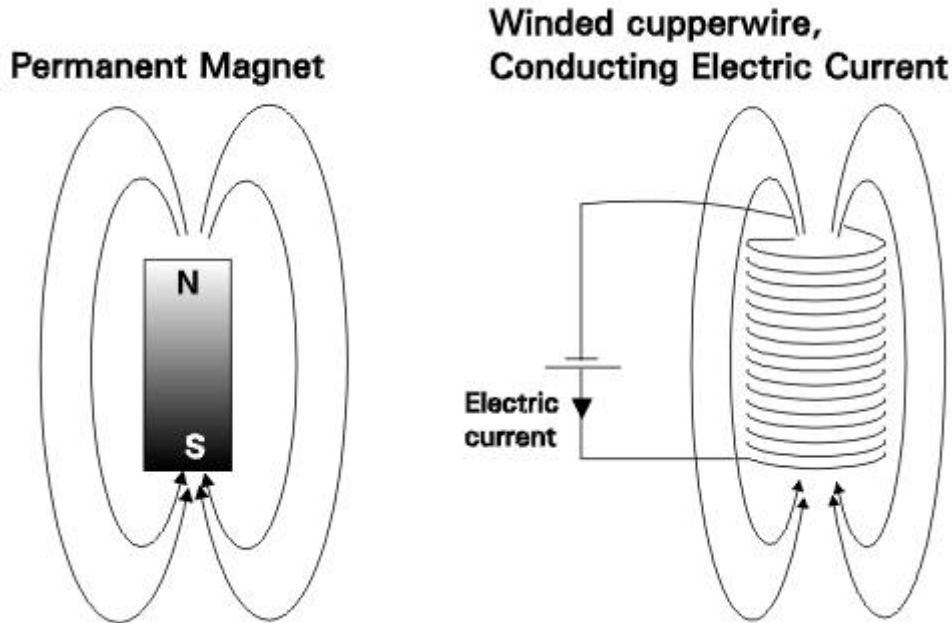

A linear motor is propelled by similar attraction and repulsion forces. The changing the magnetical poles is enabled by using winded copperwire, i.e. a coil, in stead of a permanent magnet. It is known that a metal wire, winded around a core and conducting een electric current, acts like a magnet. Among others, the produced magnetic force of an electric coil depends on

1. the amperage of the current,
2. the number of windings, and
3. the kind of core material.

Electromagnetic exiting of a constant and a commutating magnetic field:

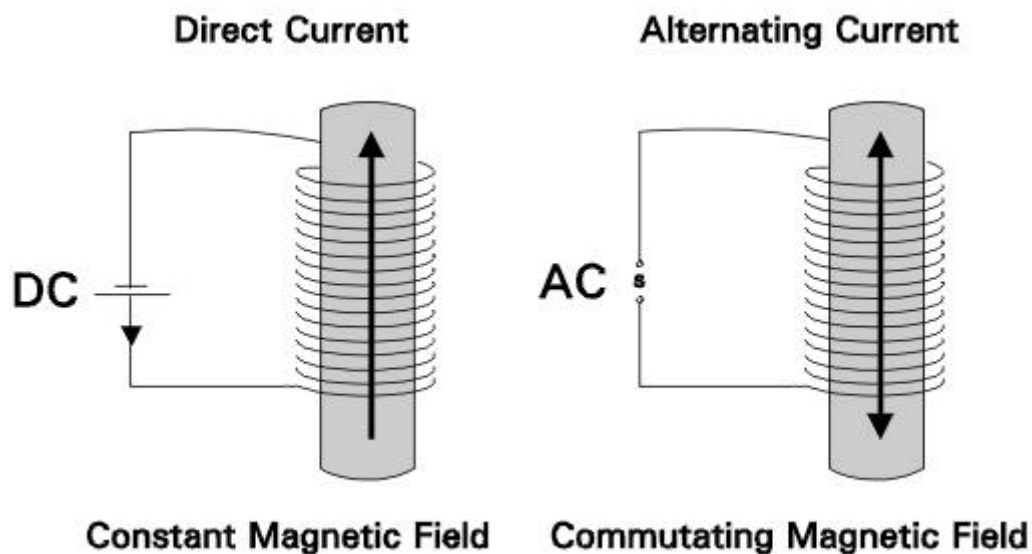

Generally iron is used as core material. Because of its very low magnetic resistance it has some very good characteristics for conducting the magnetic field. In fact the iron core can be considered as a magnet. In the case of a direct current the core behaves like a permanent magnet. In addition, reversing the phase of the current makes the magnetic poles switch. So an alternating current excites a commutating magnetic field.

Linear motor, schematic cross section:

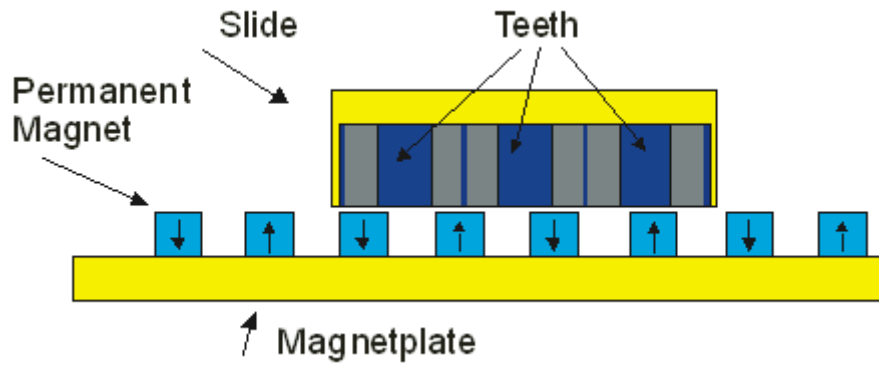

In a linear motor several coils are mounted in a slide, or coil unit. The slide is movable over a bottom plate. On the entire distance this plate is covered with permanent magnets. The plate, included with the magnet assembly, is called the magnetplate. The length of the magnetplate determines the reach of the linear motor.

The linear motor type discussed in this leaflet has coils with an iron core (see following figure). These cores that act like magnets are called 'the teeth'. The coils are supplied with an electric current

The slide is propelled by changing the current phase of each coil. The speed of change allows control of the velocity of the slide. In addition, the amperage of the current is linked to the moving force. So, in- or decreasing the amperage allows control of the motorforce.

Coil unit with three coils, schematic:

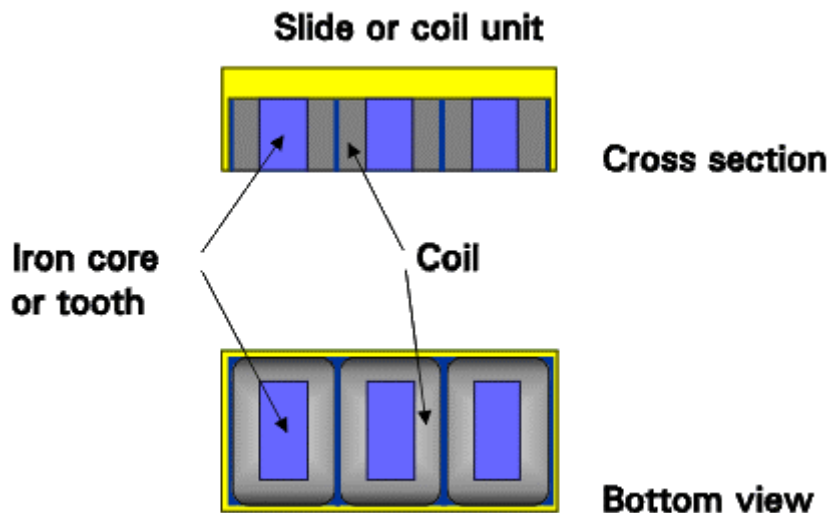

3 Phase Linear Motor AL2000

Different techniques can be applied in order to get an accurate and smooth motion of the slide. The permanent magnets are fixed on the magnetplate. So the phase of the magnetic force of each magnet is invariable. For the coils on the other hand the phase is adjustable. The slide is propagated by commutating the phase of the current. Providing each coil with a suitable phase displacement is one of the appropriate techniques for linear motors. Another point of concern is the position of the coils in respect to the permanent magnets.

Erroneous positioning and phasing

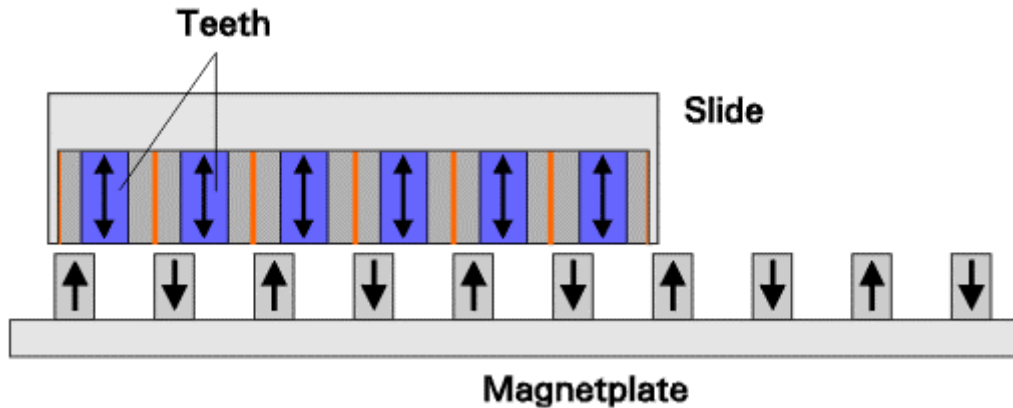

Placing the coils in the same pattern and mutual distance as the magnets, as shown in the figure is problematic. When in addition the coils are provided with equally phased current, the slide won't move at all. Considerations like these should be faced when designing a linear motor of series AL2000.

Positioning and phasing for a 3 phase linear motor AL2000

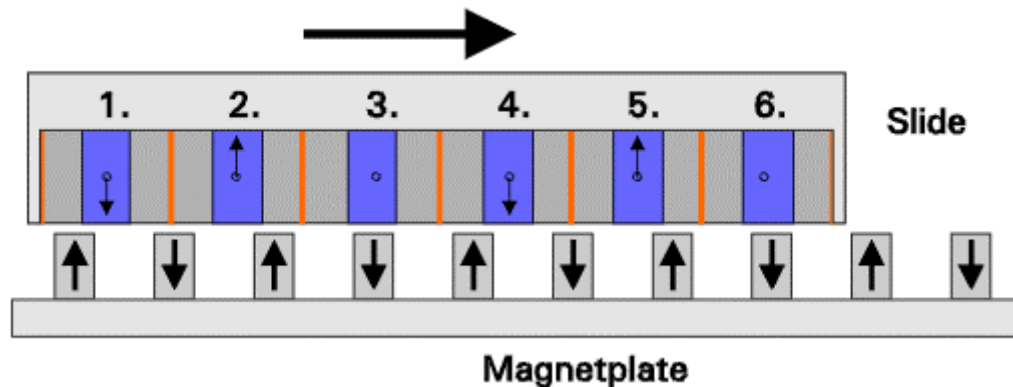

The principle of the three phase linear motor AL2000 comes to meet the mentioned problems. In the example here discussed, the coils are equally positioned in the slide with a ratio 3 to 4 compared to the magnets of the magnetplate (see figure). As a result three different groups of coils can be distinguished. Coil 1 will continuously have a comparable position as coil 4. Coil 2 and 5 are also comparably positioned as well as coil 3 and 6. Smooth and accurate motion is now obtained by providing a three phase rotary current to the coils, one phase to each group. The phase angle depends on the position of the slide. Information about this position is provided by a linear encoder.

Linear and rotary motors compared

A rotary motor opened up and laid out flat

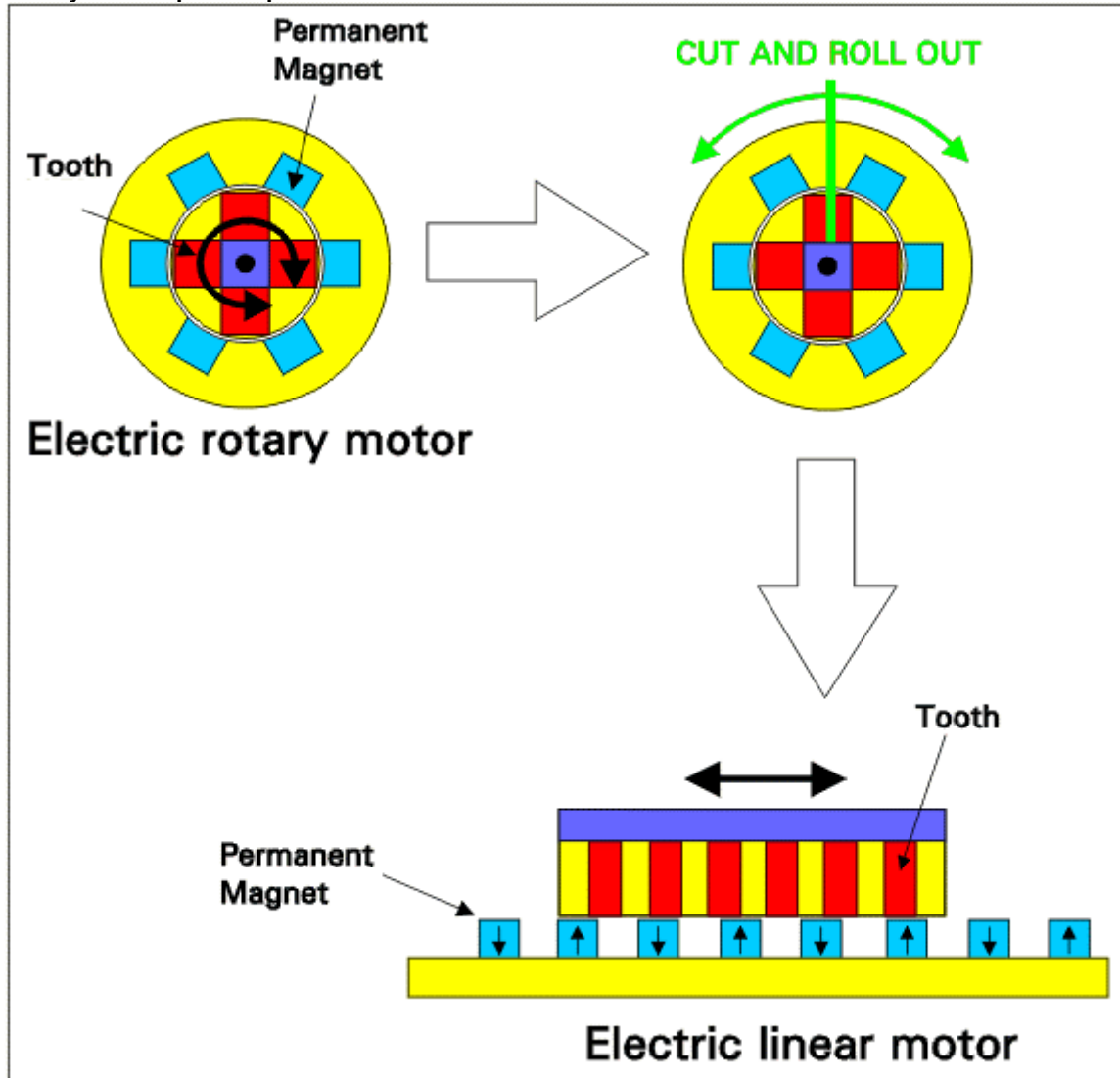

It will be notified that a linear motor is based on the same physical principles as the normal rotary electric motor. In fact a linear motor is a rotary motor opened up and laid out flat (see figure). Hereby the function of the rotor is transformed in the slide function. The torque has become a linear force and so the rotary movement has changed to a flat movement.

Because of its flat topology the main advantage of the linear motor is apparent. It generates a direct linear movement. Whereas a rotary motor needs some kind of transmission, the linear motor directly provides it.

The direct drive results in some significant advantages.

- Accurate position control and response is possible at submicron level.
- A linear motor provides a smooth and controlled motion. No velocity ripple.
- In comparison with standard rotary motor systems a high velocity and acceleration performance is obtained. This is due to the high ratio of peak force to motor inertia.
- Except for the side bearings there is no contacting surface. Friction is negligible, virtually no wear.
- The only limitation on travel displacements is the length of the magnetplate. In the case of added length there are no speed limitations nor is there a higher inertia or lower dynamic stiffness.

3. Positioning

The positioning system

Linear motor applications require a sophisticated position and velocity feedback. A linear encoder and a servo-controller are taken up in the positioning system. The position of the slide is detected by a ruler-probe combination. The linear encoder returns this information to the servocontroller.

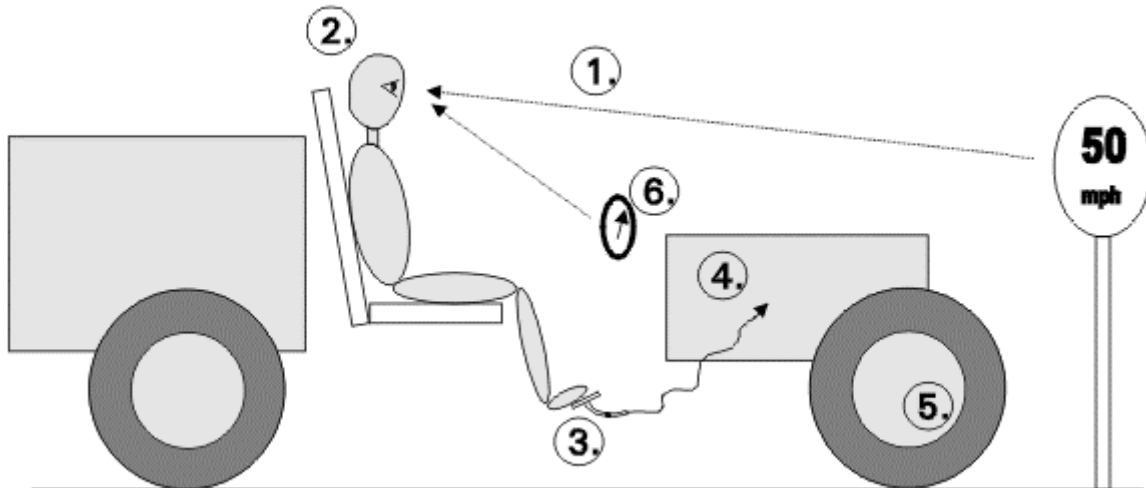

To have some impression of the positioning system a superficial comparison could be made with the speed control of an automobile. The information of the traffic sign (1) is detected and interpreted by the driver (2) and translated into an adjustment of the gas pedal (3). This results in an adjustment of the motor force (4) and consequently of the rotation speed of the wheels (5). The actual speed information is returned to the driver by the speedometer (6). As long as the desired speed is not gained this specific loop back situation is maintained.

What a linear motor system concerns the measurement unit could be compared with the driver's visual system. The measurement probe detects the position and the linear encoder translates it into the right position information. The input ports of the servo-controller act like the eye-nerves. Here the position information is returned to the driver's brain, the very servo-controller. In the controller this information is processed and translated into an appropriate voltage signal to the linear motor, comparable with the gas pedal movement. Because the linear motor needs a powerful input this signal is provided by an amplifier. A bigger amplifier supplies a larger peak force, just like a more powerful car engine produces more horse powers. Comparable with car dynamics the acceleration of a linear motor depends on the ratio of the amplifier power and the total moving load. It should be notified that the voltage signal to the linear motor is provided in the form of pulses with a fixed switching frequency and a fixed voltage. So the pulse width is the parameter to be regulated.

The position information provided by the probe is incremental. So the linear motor has to do without the absolute position of the slide. Especially when starting a motor operation this could be problematical. Herefore the slide is activated to some minimal test movement. This 'magnetic alignment' supplies the positioning system with the required information.

4. Linear motor system

Overview

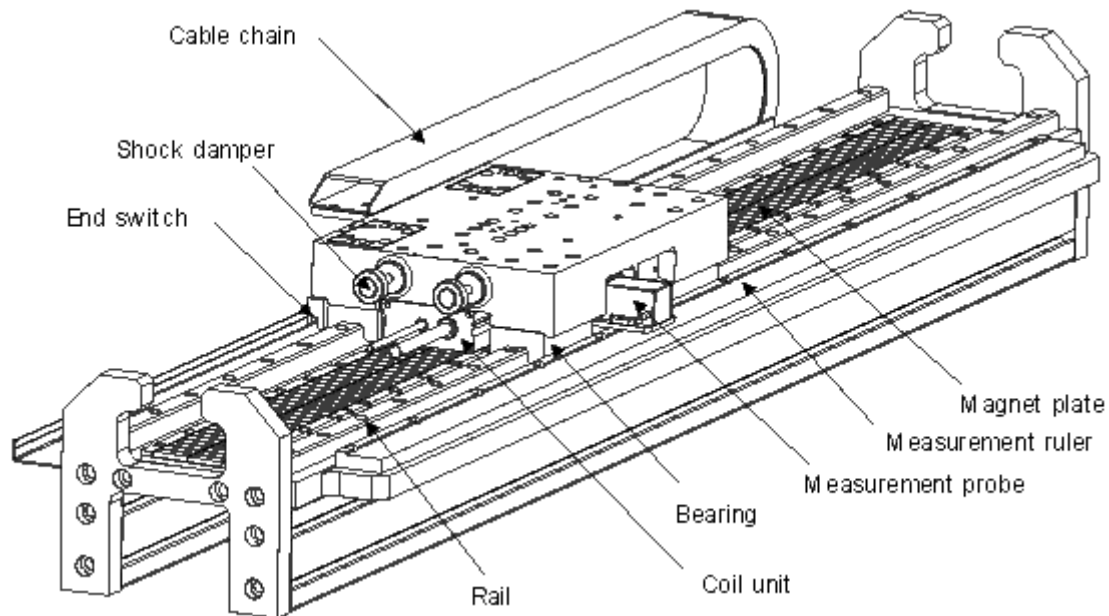

A linear motor usually is part of a bigger system. This system enables controlled movement. A complete linear motor system consist at least of the following parts:

- A mounting frame
- A magnettrack build up out of at least two magnetplates.
- A set of linear guides that support the slide and its load.
- A positioning system consisting of a servo controller, a measurement ruler and probe for position detection and a linear encoder for position feedback to the servo controller.
- A coil unit, water cooled if needed. This slide carries the functional load.
- Safety end dampers and switches to stop the movement in case of malfunctions.

In the next paragraph some practical considerations concerning these items will be discussed.

Practical considerations

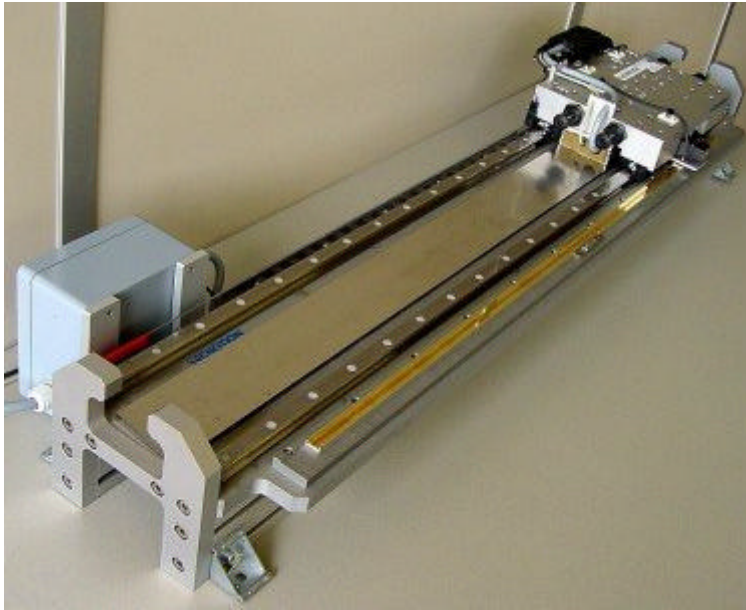

A PART OF A TOTAL MACHINE CONCEPT

A linear motor of Beckhoff Industrie Elektronik is not a system on itsself. It should be build within a total machine concept or a working unit. Depending on the application a choice has to be made between different systems. Therefore it is important to know the specifications of both the total machine concept and the linear motor types. The machine should meet all the applicable CE requirements

MOUNTING FRAME: SOLIDITY AND STABILITY

For two main reasons the mounting frame has to meet special requirements. The propelling peak forces of a linear motor are high, so the frame needs sufficient dynamic stiffness. Because of the accuracy the frame should be insensible to shocks and vibrations. Usually the magnetplate is horizontally fixed to the base of a machine or working unit. The slide will bear a functional load, such as a measurement unit or a laser cutter. Because of this load, the cabling and optional cooling lines the ratio of peak force to motor inertia could be influenced a little. It will be obvious that a vertical position of a linear motor system demands special considerations. If desired contact Beckhoff Industrie Elektronik.

RAILS AND BEARINGS

To assure a free movement the slide is provided with bearings that run smoothly on two rails or with air bearings. The rails are mounted aside the magnetplate. In addition this construction ensures the right airgap between the coil unit and the magnet plate. For the sideward positioning of the coil unit to the magnetplates a small tolerance is acceptable.

HEAT DISSIPATION

Especially in the coil unit the heat dissipation can be significant. Heatflow causes temperature differences. In some cases this could be unacceptable for accuracy or other reasons. So, special attention has to be given to the heatflow to the ambient. In some cases (water) cooling is needed.

ACCURACY

The accuracy of the positioningsystem is crucial, since the linear motor is supposed to be controlled at submicron level. For instance the accuracy can be influenced by heat expansion of the coil unit, by vibrations and shocks from the surroundings or by a lack of stiffness of the mounting frame. Generally the main restriction for the accuracy arises from this lack of stability.

Like most mechanical systems a linear motor deals with resistance, elasticity and inertia. Because of the feedback of position and velocity it also deals with measuring accuracy and certain delay times. For instance the controller has to deal with some delay because of processor and update times. Accuracy could also be limited by the fixed pulse frequency of the servo-amplifier.

Of course the linear ruler and the measurement probe should meet the desired accuracy. This requires a sophisticated ruler-probe combination. The probe should be mounted as close as possible to the working point of the complete moving unit (slide + load). The probe sends signals to the linear encoder, whereby the encoder has a resolution time. At last the linear motor itself is an electromagnetic device. It deals with resistance and selfinductance. This implies that the current in the coils always lags behind the provided voltagesignal. Since the magnetic force is directly linked to the current this means that the motorforce also lags behind.

All these items affect the accuracy of the linear motor, its small signal behaviour.

SERVOCONTROLLER

Linear motors of the AL2000 series could ideally be combined with our 3 Phase servocontrollers of the AX2000 series. The servocontroller AX2000 covers the complete rotary and linear motor range. The prepared motor-, feedback- and thermal-protection cables completes the full linear motor servo system. All default parameters of linear motor-controller combinations are defined and loadable.

BRAKING AND DAMPING

High velocities are gained at short distances. In normal conditions dynamic braking is provided by a reversed electromagnetic force. However, for short runouts braking and damping could be necessary. In certain conditions, for instance a loss of electrical power, this could be critical for safety.

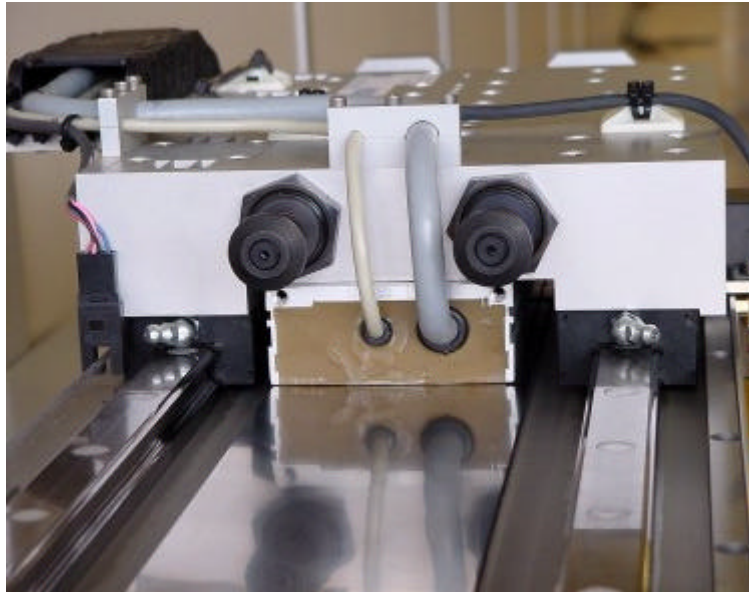

MAGNETIC FLUX AND DISTANCE

Just like a rotary motor a linear motor is propagated by an electromagnetic force. Magnets produce a so called magnetic flux, which can be considered as the density of the magnetic field. This counts for the permanent magnet as well as the electromagnetic coil. The magnetic field is densest in the direct vicinity of the magnetic pole, typically several thousand Gauss. This flux usually diminishes rapidly when measured at some centimeters from the magnet pole. Since the magnetic force depends directly on the magnetic flux, it is important to keep the gap between coil unit and magnetplate small. The gap can vary a little without losing much performance.

COGGING

The permanent magnets produce an attraction force to all magnetic materials in the vicinity. When the coil unit contains such materials, f.i. the iron core, the motorforce could be influenced. Because of the separate positioning of the magnets on the magnetplate, the magnetic field is not homogenous. So, dependent of the position of the magnets the motorforce will be disturbed. Such position dependent disturbance could make the slide cog. Beckhoff Industrie Elektronik sophisticated design meets with the problems of cogging.



CAREFUL INSTALLATION

Installing a linear motor should be done very cautious. Read the installation manual carefully. Installation only by qualified personal. Special attention should be given to the strong magnetic field in the vicinity of the magnetplates. These plates should be handled with care and with proper tools. Beware of the fact that materials or clothes get jammed between magnetplate and iron objects. For mounting and dismounting purposes magnetic field neutralizing protectionplates are to be used. Carefully follow the installation instructions of the applied servo controller and linear encoder. Electronic wiring, such as the sensor cable, should be shielded or combined to twisted pairs in order to reduce the influence of EMI.

The series AL2000 linear motor

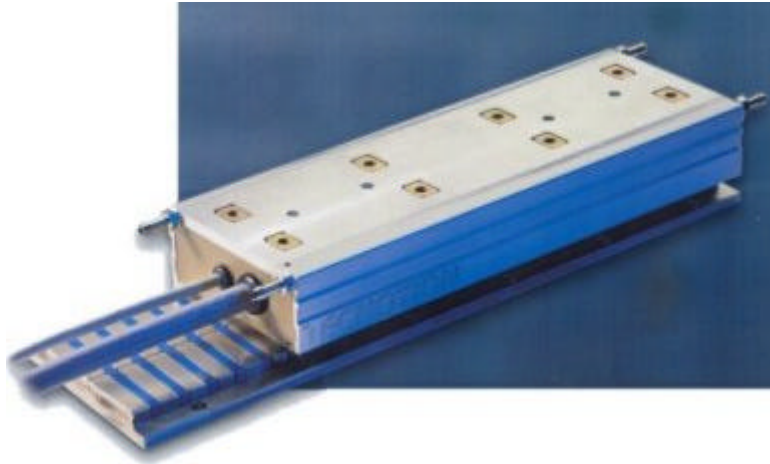

The motors of the AL2000 series are three phase ironcore linear motors in a very compact design. Coils with iron core are mounted in the slide. The slide moves over the magnetplate. The small gap between the plate and the slide is established by the use of rails and bearings. Because of the small airgap the magnetic resistance between coils and magnets is low. This results in a high magnetic force.

- Some characteristics of this linear motortype are High peak force (up to 2000 N).
- High continuous force.
- Relatively small attraction force
- Low heat dissipation.
- Controlled low cogging level.
- Dynamics and accuracy at an intermediate level.
- High speed (up to 10m/s).
- Moderate price of magnet plate.