

Hardware Data Sheet

FB1111-0140

FB1111-0141

FB1111-0142

EtherCAT[®] Piggyback Controller Boards

Version 2.0
Date: 2011-01-07

BECKHOFF

CONTENTS

1	Foreword	1
	1.1 Notes on the Documentation	1
	1.1.1 Liability Conditions	1
	1.2 Safety Instructions	1
	1.2.1 Safety Rules	1
	1.2.2 State at Delivery	1
	1.2.3 Personnel Qualification	1
	1.2.4 Description of Safety Symbols	1
	1.3 Documentation Issue Status	2
2	Overview	3
	2.1 Indicator LEDs	3
	2.2 Variant Differentiation	3
3	Process Data Interfaces	4
	3.1 PDI Configuration	4
	3.2 Power Supply	6
	3.3 Pinout	6
4	Component Placement Specification	8
	4.1 Placed/Unplaced Components	8
	4.2 Test Pads	8
	4.2.1 Port 0 – IN	8
	4.2.2 Port 1 – OUT	8
	4.2.3 Power Test Pads	9
	4.3 FB1111-0142 – 32 bit In/Out digital Interface	10
	4.3.1 Top Side of FB1111-0142	10
	4.3.2 Bottom side of FB1111-0142	11
	4.4 FB1111-0141 – Serial Peripheral Interface	12
	4.4.1 Top side of FB1111-0141	12
	4.4.2 Bottom side of FB1111-0141	13
	4.5 FB1111-0140 – 8/16 bit asynchronous Microcontroller Interface	14
	4.5.1 Top side of FB1111-0140	14
	4.5.2 Bottom side of FB1111-0140	15
5	Interfacing with the EL9820 Evaluation Kit	16
	5.1.1 Left side pin header definition	17
	5.2 EL9820 stacking examples	18
6	Electrical Specification	19
	6.1 Ratings	19
	6.2 EMC – Electro magnetic compatibility	19
7	Mechanical Specification	20
	7.1 Board Dimensions	20

7.2	Physical Connector Specification	21
7.3	Recommended Panel Opening	21
7.4	Top/Bottom Side Component Height Definition	22
8	Appendix	24
8.1	Support and Service	24
	8.1.1 Beckhoff's branch offices and representatives	24
8.2	Beckhoff Headquarters	24

TABLES

Table 1: Indicator LEDs	3
Table 2: Variants of the FB1111-014X	3
Table 3: Process data interfaces in combination with the EL9803	4
Table 4: Resistors for PDI Mapping	4
Table 5: Networks for PDI Mapping	5
Table 6: Pinout for different PDI Configurations	6
Table 7: Port 0 Test Pads	8
Table 8: Port 1 Test Pads	8
Table 9: Power Test Pads	9
Table 10 Pin description of 8 pin right angle header	17
Table 11: Typical Ratings	19

FIGURES

Figure 1: Overview of the FB1111-014X 3

Figure 2: PDI Connector Power Pin Distribution 6

Figure 3: Example for placed/unplaced components 8

Figure 4: Pads of resistor networks and single resistors 8

Figure 5: EL9803 Adapter board – Top Side..... 16

Figure 6: EL9803 Adapter board – Bottom Side 17

Figure 7: Left side right angle header pinout..... 17

Figure 8: Microcontroller Configuration with EL9803 18

Figure 9: SPI Configuration with EL9803 18

Figure 10: Connection to GND-Earth 19

Figure 11: Board dimensions of the FB1111 – Top View..... 20

Figure 12: Recommended Panel Opening 21

Figure 13: Component height zones for the top side of FB1111-014X..... 22

Figure 14: Component height zones for the bottom side of FB1111-014X..... 23

ABBREVIATIONS

μController	Microcontroller
as.	Asynchronous
DC	Direct Current
EEPROM	Electrically Erasable Programmable Read Only Memory. Non-volatile memory used to store ESC configuration and description.
ESC	EtherCAT Slave Controller
EtherCAT	Real-time Standard for Industrial Ethernet Control Automation Technology
GND-Earth	Ground-Earth
LED	Light Emitting Diode, used as an indicator
PCB	Printed Circuit Board
PDI	Process Data interface
SPI	Serial Peripheral Interface
RJ45	FCC Registered Jack, standard Ethernet connector (8P8C)

1 Foreword

1.1 Notes on the Documentation

This description is only intended for the use of trained specialists in control and automation engineering who are familiar with the applicable national standards. It is essential that the following notes and explanations are followed when installing and commissioning these components.

1.1.1 Liability Conditions

The responsible staff must ensure that the application or use of the products described satisfy all the requirements for safety, including all the relevant laws, regulations, guidelines and standards.

The documentation has been prepared with care. The products described are, however, constantly under development. For that reason the documentation is not in every case checked for consistency with performance data, standards or other characteristics. None of the statements of this manual represents a guarantee (Garantie) in the meaning of § 443 BGB of the German Civil Code or a statement about the contractually expected fitness for a particular purpose in the meaning of § 434 par. 1 sentence 1 BGB. In the event that it contains technical or editorial errors, we retain the right to make alterations at any time and without warning. No claims for the modification of products that have already been supplied may be made on the basis of the data, diagrams and descriptions in this documentation.

© This documentation is copyrighted. Any reproduction or third party use of this publication, whether in whole or in part, without the written permission of Beckhoff Automation GmbH, is forbidden.

1.2 Safety Instructions

1.2.1 Safety Rules

The responsible staff must ensure that the application or use of the products described satisfy all the requirements for safety, including all the relevant laws, regulations, guidelines and standards.

1.2.2 State at Delivery

All the components are supplied in particular hardware and software configurations appropriate for the application. Modifications to hardware or software configurations other than those described in the documentation are not permitted, and nullify the liability of Beckhoff Automation GmbH.

1.2.3 Personnel Qualification

This description is only intended for the use of trained specialists in control and automation engineering who are familiar with the applicable national standards.

1.2.4 Description of Safety Symbols

The following safety symbols are used in this operating manual. They are intended to alert the reader to the associated safety instructions.



Danger This symbol is intended to highlight risks for the life or health of personnel.



Warning This symbol is intended to highlight risks for equipment, materials or the environment.



Note This symbol indicates information that contributes to better understanding.

1.3 Documentation Issue Status

Version	Comment
0.1	<ul style="list-style-type: none"> • First Version
0.2	<ul style="list-style-type: none"> • Figure for PDI Connector supply added • PDI-Pinout checked and modified • Section for electrostatic protection added • Figures of component placement updated.
0.3	<ul style="list-style-type: none"> • Description of EL9803 added • Figures illustrating component heights added
0.4	<ul style="list-style-type: none"> • Foreword added • Format corrections
0.5	<ul style="list-style-type: none"> • Corrections in figures
0.6	<ul style="list-style-type: none"> • Errors in sections 4 removed
1.0	<ul style="list-style-type: none"> • First official release
1.1	<ul style="list-style-type: none"> • Modification of component height values in chapter 7.4
1.2	<ul style="list-style-type: none"> • Dimension added in Figure 10
1.3	<ul style="list-style-type: none"> • Table added in chapter 3 • Figure added in chapter 4 • Modifications in chapter 5
1.4	<ul style="list-style-type: none"> • Operating- and storage temperature recommendations
1.5	<ul style="list-style-type: none"> • EEPROM reprogramming information added in chapter 3
1.6	<ul style="list-style-type: none"> • R525 changed to "placed" for SPI-PDI in Table 4
1.7	<ul style="list-style-type: none"> •
1.8	<ul style="list-style-type: none"> • Comment in chapter 3 concerning EL9800_A
1.9	<ul style="list-style-type: none"> • CPU_CLK_IN signal for synchronous μ-Controller interface in Table 6 added
2.0	<ul style="list-style-type: none"> • PIN 30 changed to D[9] in Table 6

2 Overview

The EtherCAT Piggyback controller boards FB1111-014X combine an ET1100 EtherCAT Slave Controller, two EtherCAT ports and a PDI-Connector on a printed circuit board. The Piggyback controller boards can as well be used for EtherCAT evaluation purposes as assembled into customer end products. Three variants with different Process Data Interfaces (PDIs) are existing in order to cooperate with the most commonly known hardware interfaces like digital IO, SPI and Microcontroller.

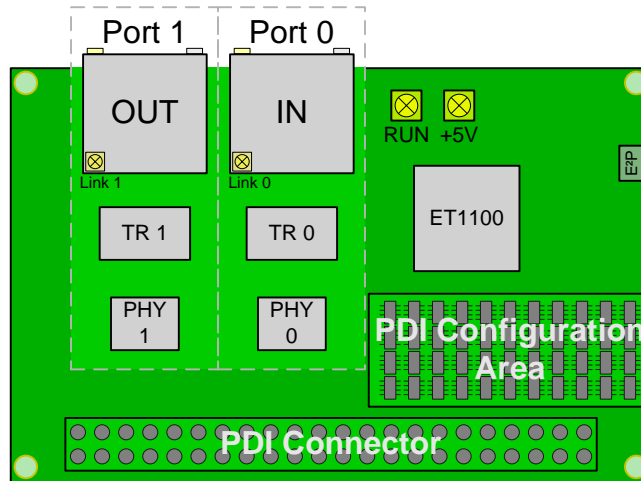

Figure 1: Overview of the FB1111-014X

The board is structured in areas for Port 0 and Port 1, the PDI Connector, a PDI Configuration Area, EEPROM, LEDs, and the ET1100 EtherCAT Slave Controller. While the EtherCAT port configuration, LEDs, ET1100 and EEPROM are identical for the different variants of the FB1111-014X, the PDI Configuration Area differs in order to achieve different PDI Connector pinouts. Each EtherCAT port in Figure 1 combines a PHY, magnetics and an RJ45 connector. The PDI Configuration Area is a field of resistors. Different pinouts on the PDI connector can be achieved by different resistor combinations in this area. (See chapter 3.)

2.1 Indicator LEDs

Four LEDs for information about the device status are available on all three variants of the FB1111. Table 1 is giving an overview over the indicator LEDs on the PCB.

Table 1: Indicator LEDs

LED	Comment
+5V	Indicates 5V power supply
RUN	RUN indicator (LED) for application state
Link 0	Link/Act Indicator (LED) for port 0
Link 1	Link/Act Indicator (LED) for port 1

2.2 Variant Differentiation

The three variants of the FB1111-014X are corresponding to three different PDI configurations. The type of PDI interface can be identified by the last position in the product code. In Table 2 the variants of the FB1111-014X are listed with respect to the different PDI interfaces.

Table 2: Variants of the FB1111-014X

Product Code	Sub Code	PDI Interface	Comment
FB1111	0140	µController	16/8 bit asynchronous Microcontroller Interface
FB1111	0141	SPI	Serial Peripheral Interface (Slave)
FB1111	0142	Digital IO	32 bit In/Out digital interface

3 Process Data Interfaces

The Process Data Interface is used to communicate with external hardware. The printed circuit board of the FB1111 supports three different PDI configurations. Thus the FB1111-0142 can be converted into the FB1111-0140 and FB1111-0141 by replacing resistors in the PDI Configuration Area. As the EL9820 Evaluation Kit contains the EL9803 adapter board, manual modification of the FB1111-0142 is unnecessary. Using the EL9803, the SPI and μ -Controller interfaces can be realized without modifying the FB1111-0142 piggyback controller board. Anyhow for in system testing manual modification of the PDI Configuration Area may be necessary. Therefore in chapter 0 resistor mapping is listed. According to this mapping the signal pinout on the process data interface connector is shown in chapter 3.3.

Table 3 gives an overview about the FB1111-014X and EL9803 combinations. In chapter 5 detailed information about the usage of the EL9803 in combination with the FB1111-0142 piggyback controller board is given.

Table 3: Process data interfaces in combination with the EL9803

Piggyback Variant	Digital IO	μ -Controller	SPI
FB1111-0140		X	
FB1111-0141			X
FB1111-0142	X		
FB1111-0142		with EL9803 in μ C-Position	
FB1111-0142			with EL9803 in SPI-Position

The Process Data Interface can be changed by reprogramming the EtherCAT configuration EEPROM using TwinCAT.



Note

Usage of the EL9803 adaptor board becomes obsolete, if the FB1111-014X is used in combination with the EL9800_4A evaluation board.

3.1 PDI Configuration

Table 4 and Table 5 are showing the resistor and resistor network configuration for the different PDI interfaces. Additionally to the designator (first column) the value (second column) and the footprint of the desired resistor (third column) are listed. In the following columns a "X" is set, if the associated resistor has to be placed on the PCB.

Table 4: Resistors for PDI Mapping

Designator	Value	Footprint	0142 - 32bit Digital IO	0141 - SPI	0140 - 16bit as. μ C
R500	0R	0603		X	X
R501	4.7k	0603			X
R502	0R	0603	X		
R503	4.7k	0603	X		
R504	0R	0603		X	X
R505	4.7k	0603			X
R506	0R	0603	X		
R507	0R	0603		X	X
R508	0R	0603			X
R509	0R	0603	X		
R510	0R	0603	X		
R511	0R	0603			X
R512	0R	0603		X	
R513	0R	0603			X
R514	0R	0603		X	X

Designator	Value	Footprint	0142 - 32bit Digital IO	0141 - SPI	0140 - 16bit as. μ C
R515	0R	0603		X	
R516	0R	0603	X		
R517	0R	0603		X	X
R518	0R	0603	X		
R519	0R	0603	X		
R520	0R	0603	X		
R521	0R	0603		X	X
R522	0R	0603	X		
R523	0R	0603			X
R524	0R	0603		X	
R525	0R	0603		X	X
R526	0R	0603			X
R527	0R	0603		X	
R528	0R	0603	X		
R529	0R	0603	X		
R530	0R	0603	X		
R531	4.7k	0603			X

Table 5: Networks for PDI Mapping

Designator	Value	Footprint	0142 - 32bit Digital IO	0141 - SPI	0140 - 16bit as. μ C
RN500	4Y0R	1206	X		
RN501	4Y0R	1206	X		
RN502	4Y0R	1206	X		
RN503	4Y0R	1206	X		
RN504	4Y0R	1206	X		
RN505	4Y0R	1206	X		
RN506	4Y0R	1206			X
RN507	4Y0R	1206		X	X
RN508	4Y0R	1206		X	X
RN509	4Y0R	1206		X	X
RN510	4Y0R	1206		X	X
RN511	4Y0R	1206		X	X
RN512	4Y0R	1206		X	X
RN513	4Y0R	1206	X		



Note

4Y0R refers to a network of four independent resistors with 0R resistance. For example resistors from PHYCOMP of the type ARV241 1206 0R can be used.



Warning

Incorrect modification of the resistor configuration can cause serious damage to the FB1111 EtherCAT piggyback controller board. Modification of the PDI Configuration is on the users own risk and therefore not covered by warranty.

3.2 Power Supply

Figure 2 shows the distribution of the power pins on the PDI Connector from top side view.

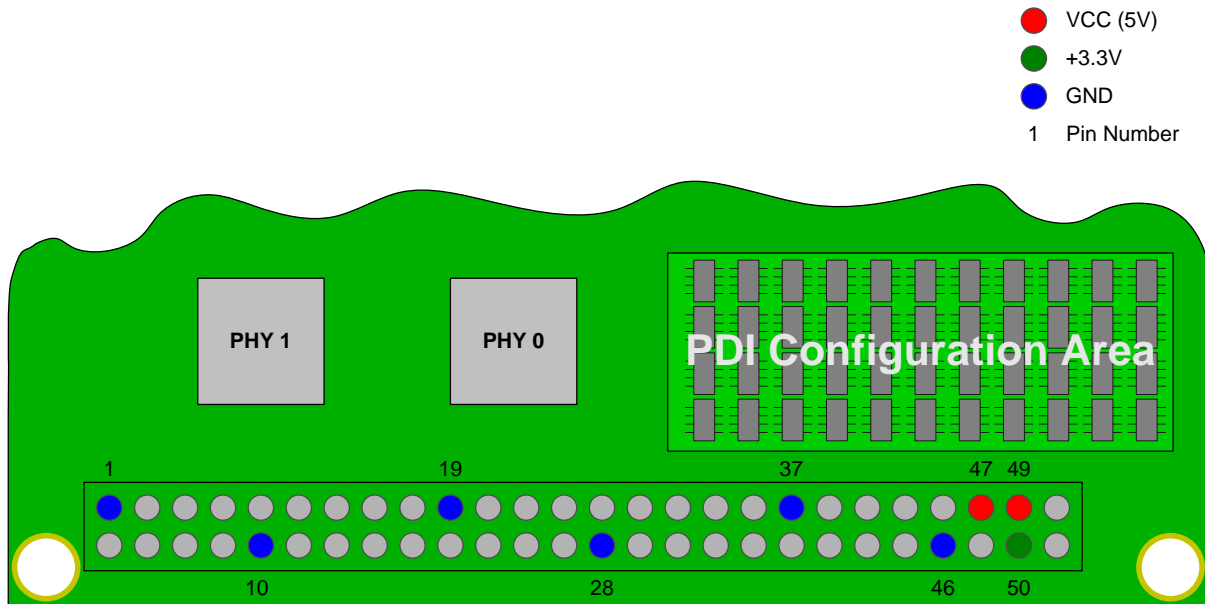

Figure 2: PDI Connector Power Pin Distribution

The Pins 47 and 49 have to be supplied with +5V V_{CC} . Pin 50 is a 3.3V Output from one DC-DC converter on the FB1111-014X. The power supply on the FB1111-014X is divided in two sections. One converter is supplying the PHYs for port 0 and 1. The second DC-DC converter supplies the ET1100 ASIC and all other parts on the printed circuit board. In consequence, the maximum current that can be driven through the 3.3V output (Pin 50) is limited to 100mA. The GND pins, which are marked blue, have to be connected to a ground plane on the supplying PCB. All in- and outputs are 3.3V compatible. Applying higher voltages will cause serious damage to the device.

3.3 Pinout

Table 6: Pinout for different PDI Configurations

Pin number	Port	0142 - 32bit Digital IO	0141 - SPI	0140 - 16bit as. μC
1		GND		
2	PA0	I/O[0]	GPI[6]	A[0]
3	PA1	I/O[1]	GPI[5]	A[1]
4	PA2	I/O[2]	GPI[4]	A[2]
5	PA3	I/O[3]	GPO[7]	A[3]
6	PA4	I/O[4]	GPO[6]	A[4]
7	PA5	I/O[5]	GPO[5]	A[5]
8	PA6	I/O[6]	GPO[4]	A[6]
9	PA7	I/O[7]	GPI[3]	A[7]
10		GND		
11	PB0	I/O[8]	GPI[2]	A[8]
12	PB1	I/O[9]	GPI[1]	A[9]
13	PB2	I/O[10]	GPI[0]	A[10]
14	PB3	I/O[11]	GPO[3]	A[11]
15	PB4	I/O[12]	GPO[2]	A[12]
16	PB5	I/O[13]	EEPROM Loaded	
17	PB6	I/O[14]	GPO[1]	A[13]
18	PB7	I/O[15]	GPI[11]	CPU_CLK_IN

Pin number	Port	0142 - 32bit Digital IO	0141 - SPI	0140 - 16bit as. μ C
19		GND		
20	PC0	I/O[16]	GPI[7]	D[0]
21	PC1	I/O[17]	GPO[8]	D[1]
22	PC2	I/O[18]	SPI_SEL	D[2]
23	PC3	I/O[19]	GPO[10]	D[3]
24	PC4	I/O[20]	GPO[11]	D[4]
25	PC5	I/O[21]	GPI[8]	D[5]
26	PC6	I/O[22]	SPI_INT	D[6]
27	PC7	I/O[23]	GPI[10]	D[7]
28		GND		
29	PD0	I/O[24]	SPI_D_IN	D[8]
30	PD1	I/O[25]	GPO[13]	D[9]
31	PD2	I/O[26]	SPI_D_OUT	D[10]
32	PD3	I/O[27]	GPO[15]	D[11]
33	PD4	I/O[28]	GPI[12]	D[12]
34	PD5	I/O[29]	GPI[13]	D[13]
35	PD6	I/O[30]	GPI[14]	D[14]
36	PD7	I/O[31]	GPI[15]	D[15]
37		GND		
38	PE0	WD_TRIGGER	SPI_CLK	nCS
39	PE1	OUT_VALID	N.C.	nRD
40	PE2	SOF	N.C.	nWR
41	PE3	N.C.	N.C.	nBHE
42	PE4	SYNC[0]/LATCH[0]		
43	PE5	SYNC[1]/LATCH[1]		
44	PE6	LATCH_IN	N.C.	nINT
45	PE7	OE	N.C.	nBUSY
46		GND		
47		VCC		
48		N.C.		
49		VCC (5V Input)		
50		3.3V Out		
51	PF0	OE_CONF	GPO[0]	A[14]
52	PF1	CLK25_OUT	N.C.	A[15]

4 Component Placement Specification

In the following chapters the component placement specification in terms of reference designators and component values are listed for the three variants of the FB1111 EtherCAT piggyback controller board.

4.1 Placed/Unplaced Components

As the variants of the FB1111 are all based on one printed circuit board, the different PDI configurations are achieved by alternative component placements. Figure 3 is an example for placed and unplaced components. Designators for placed components are surrounded by a rectangle. Components that are not mounted for a specific variant are also referenced by a designator, but without the surrounding rectangle.



Figure 3: Example for placed/unplaced components

Most of the resistor pairs within the PDI configuration area are sharing one pad with each other. When modifying the resistor configuration care have to be taken in order to connect the corresponding pads with each other correctly. An example is shown in Figure 4 for single resistors as for an resistor network.

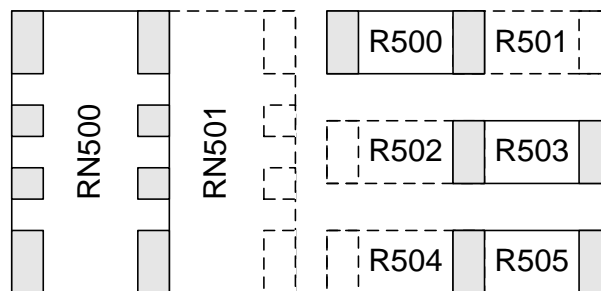

Figure 4: Pads of resistor networks and single resistors

4.2 Test Pads

Independent from the specific variant, a number of test pads are available on the piggyback controller board.

4.2.1 Port 0 – IN

Table 7: Port 0 Test Pads

Designator	Signal	Connected To
TP601	TX_ENABLE	U600 Pin 16
TP602	RX_DV	U600 Pin 9
TP603	GND	GND

4.2.2 Port 1 – OUT

Table 8: Port 1 Test Pads

Designator	Signal	Connected To
TP600	TX_ENABLE	U601 Pin 16
TP604	RX_DV	U601 Pin 9
TP605	GND	GND

4.2.3 Power Test Pads

Table 9: Power Test Pads

Designator	Signal	Connected To
TP800	+2.5V Core	ET1100
TP604	+3.3V	+3.3V
TP605	GND	GND

4.3 FB1111-0142 – 32 bit In/Out digital Interface

4.3.1 Top Side of FB1111-0142

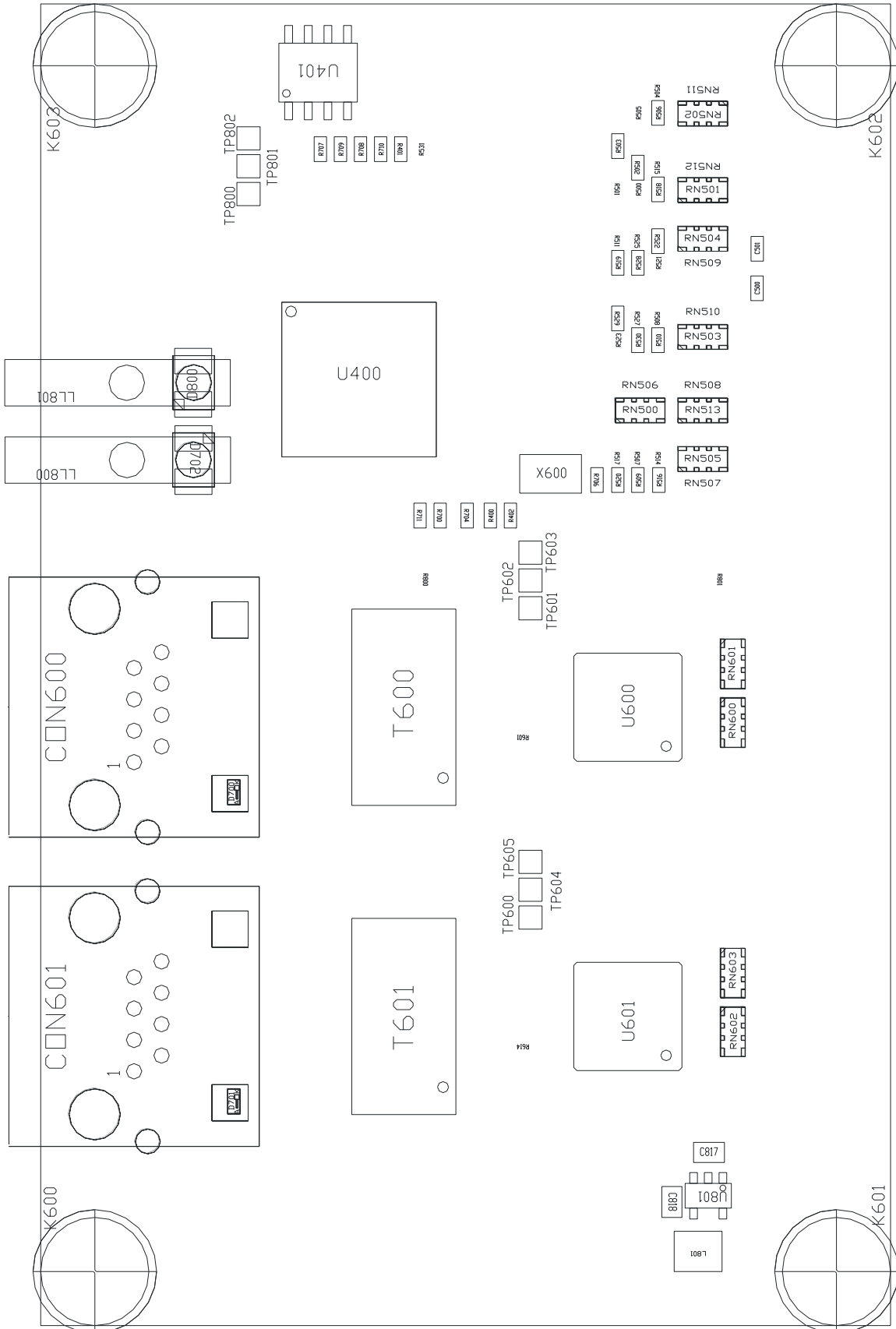

4.3.2 Bottom side of FB1111-0142

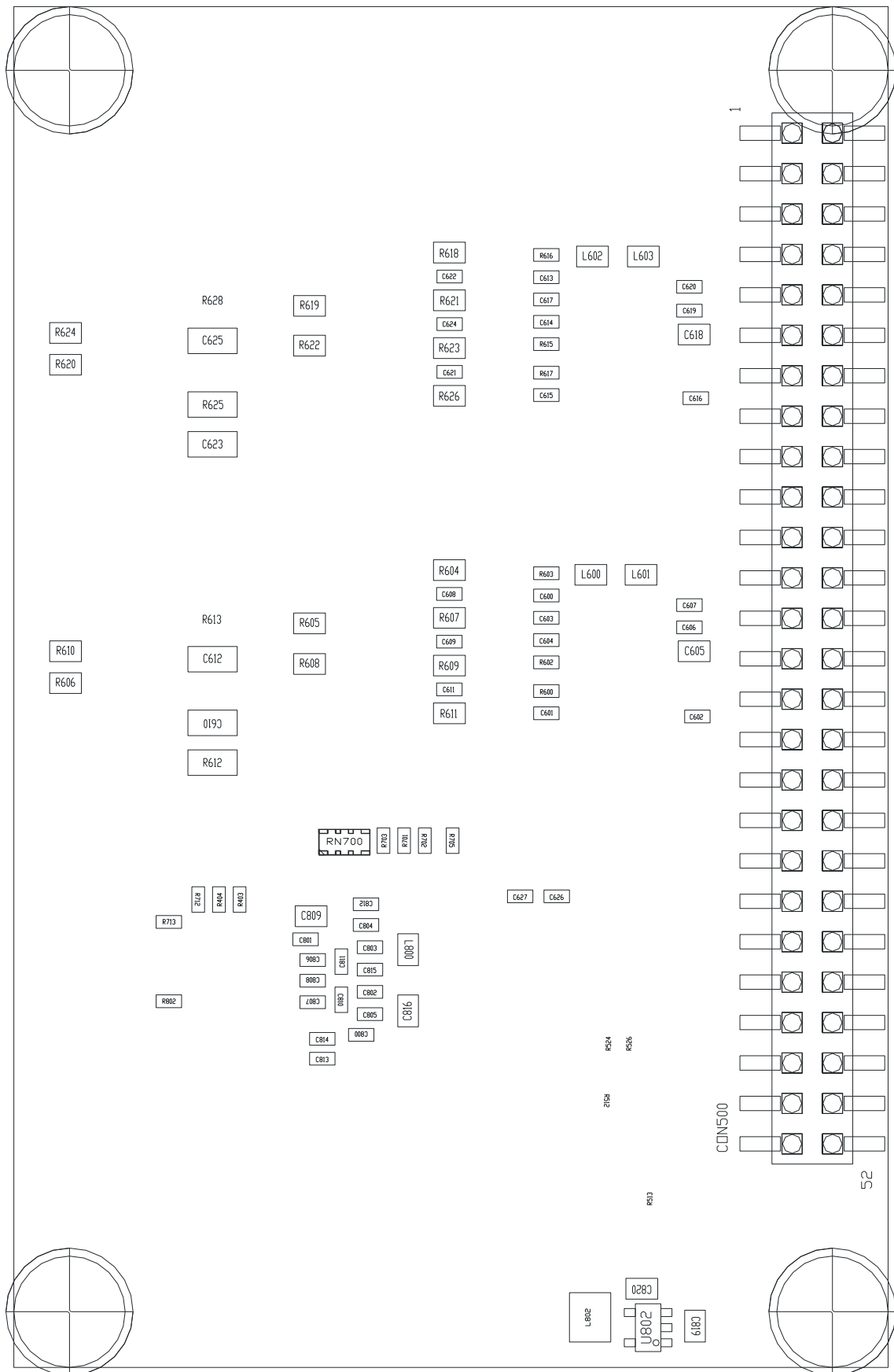

4.4 FB1111-0141 – Serial Peripheral Interface

4.4.1 Top side of FB1111-0141

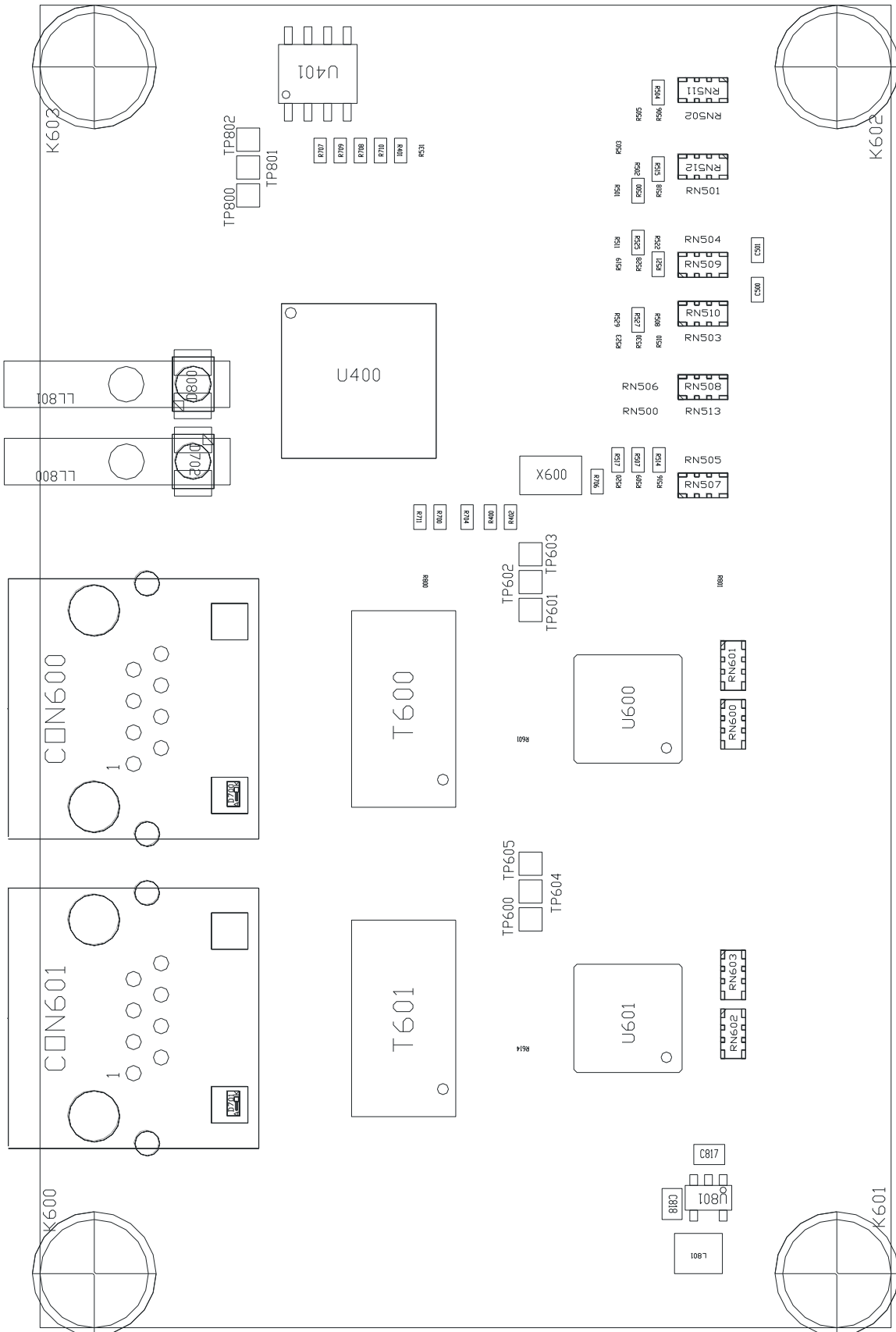

4.4.2 Bottom side of FB1111-0141

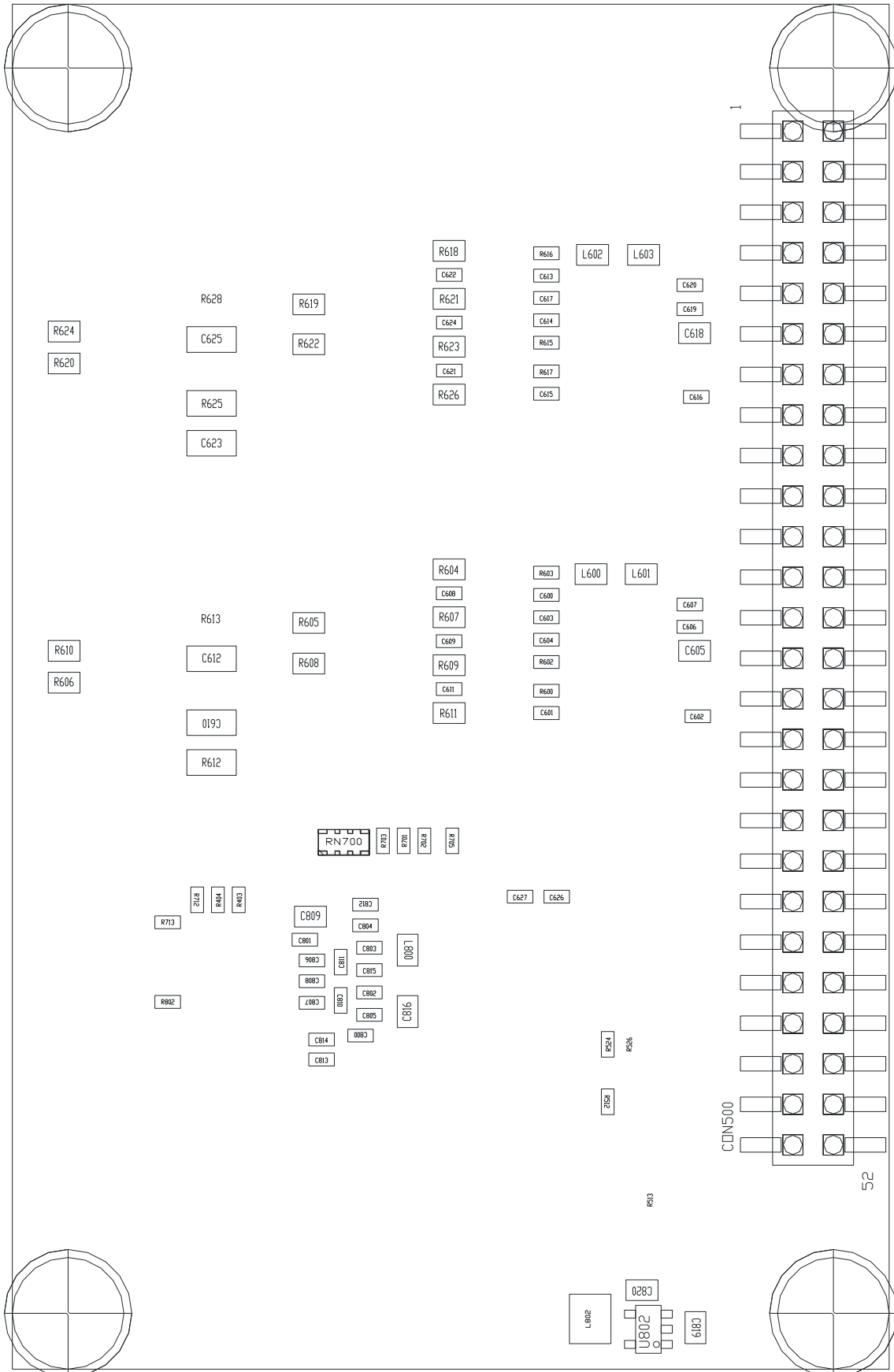

4.5.2 Bottom side of FB1111-0140

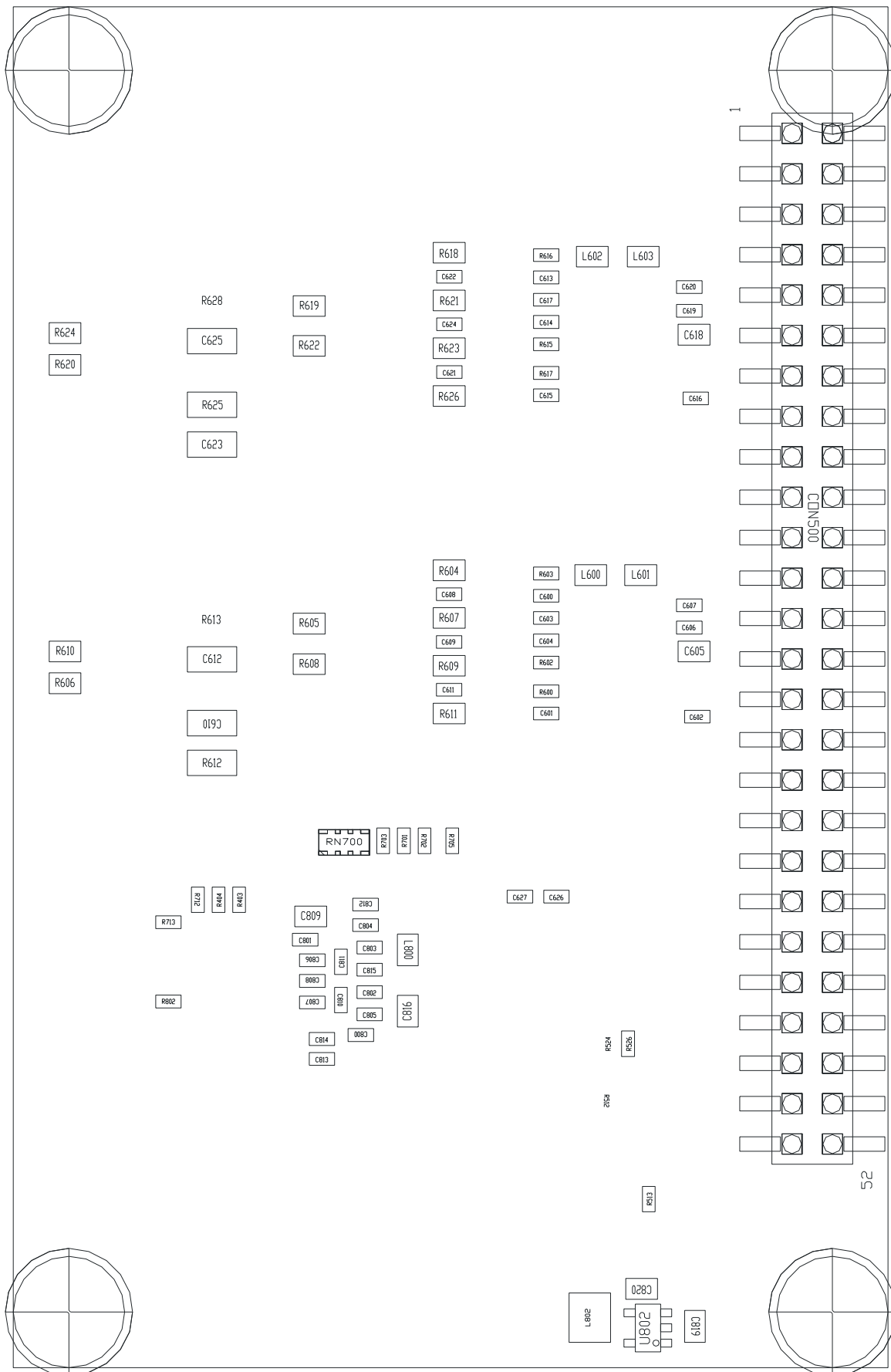

5 Interfacing with the EL9820 Evaluation Kit

As the FB1111 piggyback controller board variant with the sub code 0142 (32 bit In/Out digital Interface) uses all available signals on the PDI connector, it can be programmed to implement the two remaining PDIs.

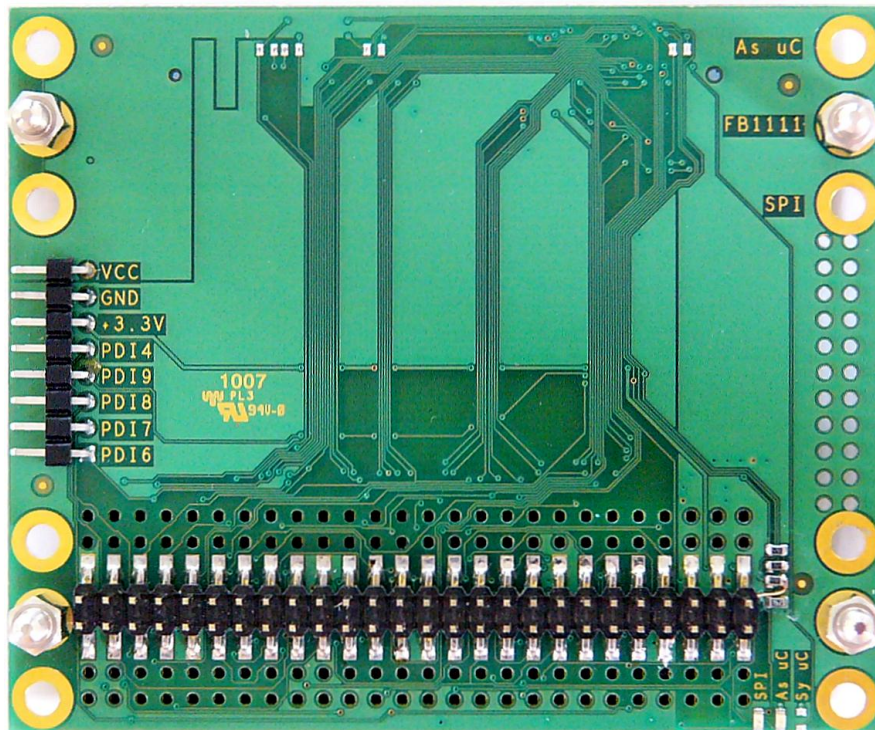

Figure 5: EL9803 Adapter board – Top Side

Due to the different PDI connector pinouts in comparison with the variants 0141 and 0140 an additional board is needed, that maps the physical digital PDI signals to the Microcontroller, respectively SPI, interface of the EL9820 Evaluation Kit. Therefore the EL9803 adapter board can be used to realize all three available PDIs on the EL9820 Evaluation Kit with just one FB1111-0142.

Figure 5 shows the top side of the EL9803 Adapter Board. The FB1111-0142 has to be placed on the position, labelled with “FB1111” on the top most right of Figure 5. The adapter board is delivered with spacer pins at the position, where the FB1111-0142 has to be attached at.

The EL9820 Evaluation Kit connects with the EL9803 Adapter Board from the bottom side (Figure 6) of the of the adapter board. The holes labelled with “As uC” and “SPI” are referencing the position of the EL9820 Evaluation Board for the desired Process Data Interface. In addition to the labelled position holes two LEDs are placed on the board (bottom right edge of Figure 5). The left LED indicates physical SPI mapping between EL9820 and EL9803. The right one indicates asynchronous Microcontroller interfacing.

Only 50 PDI signals are provided by the EL9820 Evaluation Kit in comparison to the 52 signals of the EtherCAT piggyback controller board FB1111-0142, respectively the EL9803 Adapter Board. The boards FB1111-0142 and EL9803 are supporting full functionality of the EtherCAT Evaluation Kit EL9820. The additional pins will be used in future versions of the EL9820.



Figure 6: EL9803 Adapter board – Bottom Side

The PCB colour may vary between green, black and red.

5.1.1 Left side pin header definition

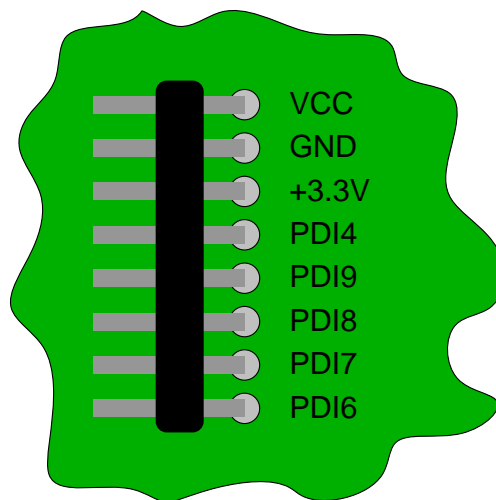

Figure 7: Left side right angle header pinout

Figure 7 shows the pinout of the header on left side of the EL9803's top. Depending on the selected process data interface, the definition of the pins PDI4 and PDI6 to PDI9 are differing. The pin names given here are based on the ET1100 PDI pinout. Thus detailed information about pin description and electrical specification of these pins can be found in the ET1100 Hardware Data Sheet that can be downloaded from the company's website. An overview of the pinout is given in the following table.

Table 10 Pin description of 8 pin right angle header

Pin name	0141 - SPI	0140 - 16bit as. µC
PDI4	SPI_IRQ	IRQ
PDI6	EEPROM_Loaded	
PDI7	n.c.	ADR[15]
PDI8	GPO[0]	ADR[14]
PDI9	GPO[1]	ADR[13]

5.2 EL9820 stacking examples

In this chapter the two stacking alternatives of the EL9803 Adapter Board on the EL9820 Evaluation Kit is shown. Figure 8 represents the asynchronous microcontroller configuration, while Figure 9 demonstrates the SPI configuration of the three boards.

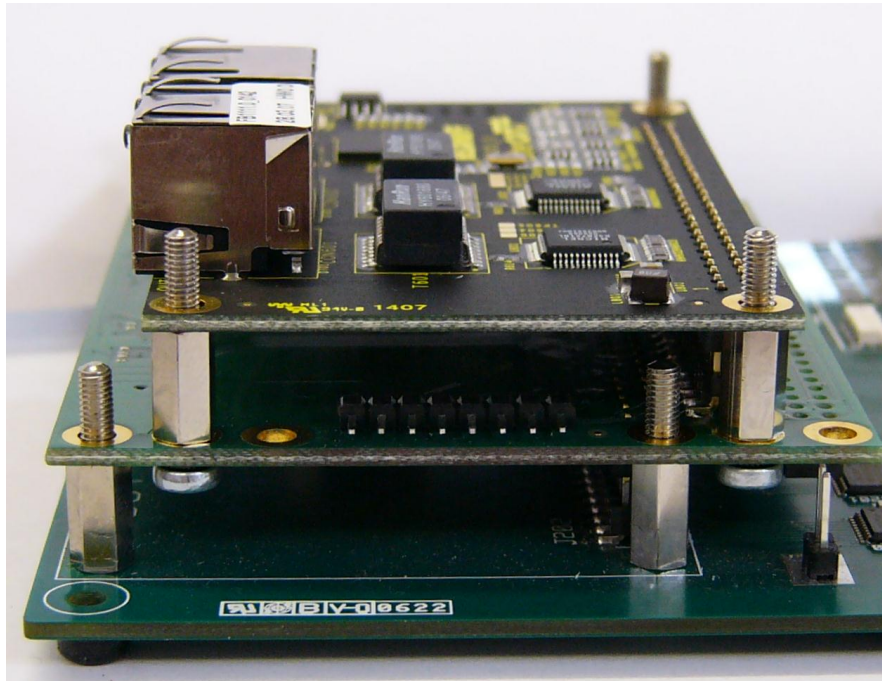

Figure 8: Microcontroller Configuration with EL9803

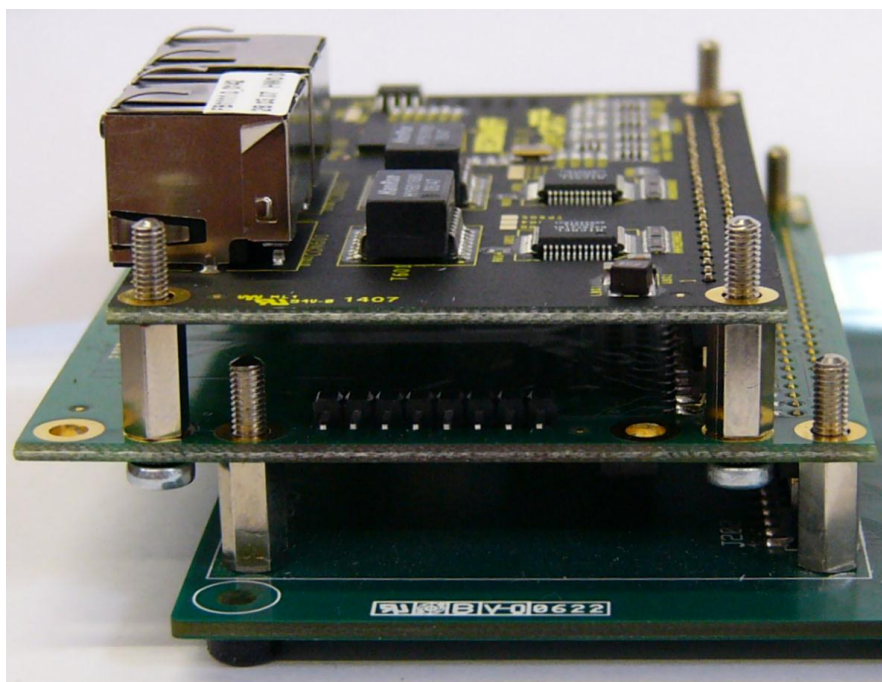

Figure 9: SPI Configuration with EL9803

6 Electrical Specification

6.1 Ratings

Table 11: Typical Ratings

Symbol	Parameter	Condition	Min	Typ	Max	Units
V_{CC}	Board Supply Voltage		4.0	5.0	5.5	V
I_{CC}	Board Supply Current	1 Port 2 Ports 1 Port + full PDI 2 Ports + full PDI	100	140 190 300 350	700	mA
$\vartheta_{Storage}$	Storage temperature		-65		105	°C
$\vartheta_{Ambient}$	Ambient temperature		-40		70	°C



Note

Additional information about the ratings, operation conditions and DC characteristics can be found in the EtherCAT ET1100 hardware data sheet.

6.2 EMC – Electro magnetic compatibility

For proper protection against damage caused by electrostatic discharge, the top left mounting hole of the EtherCAT piggyback controller board has to be connected to a massive panel or plate that is connected with GND-Earth. The remaining three holes have to be used for mechanical fixation of the piggyback controller board.

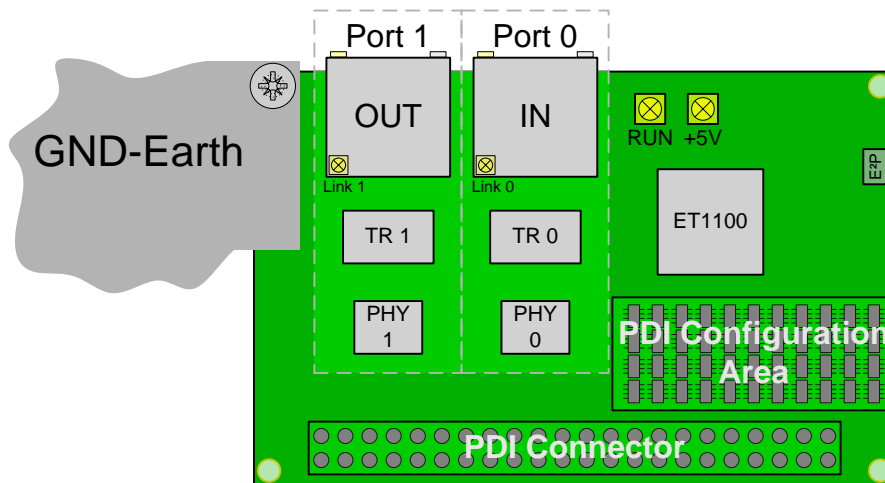

Figure 10: Connection to GND-Earth

Suitable screw dimensions are: M3x6 DIN-7985.

7 Mechanical Specification

As the EtherCAT piggyback controller board FB1111-014x can be assembled with customer hardware to complex end user devices, board dimensions and assembly recommendations have to be taken in account. In 7.1 the board dimensions including mounting and contact hole positions and diameters from top view are shown. Panel opening recommendations are shown in section 7.2. All dimensions are drawn in millimeters.

7.1 Board Dimensions

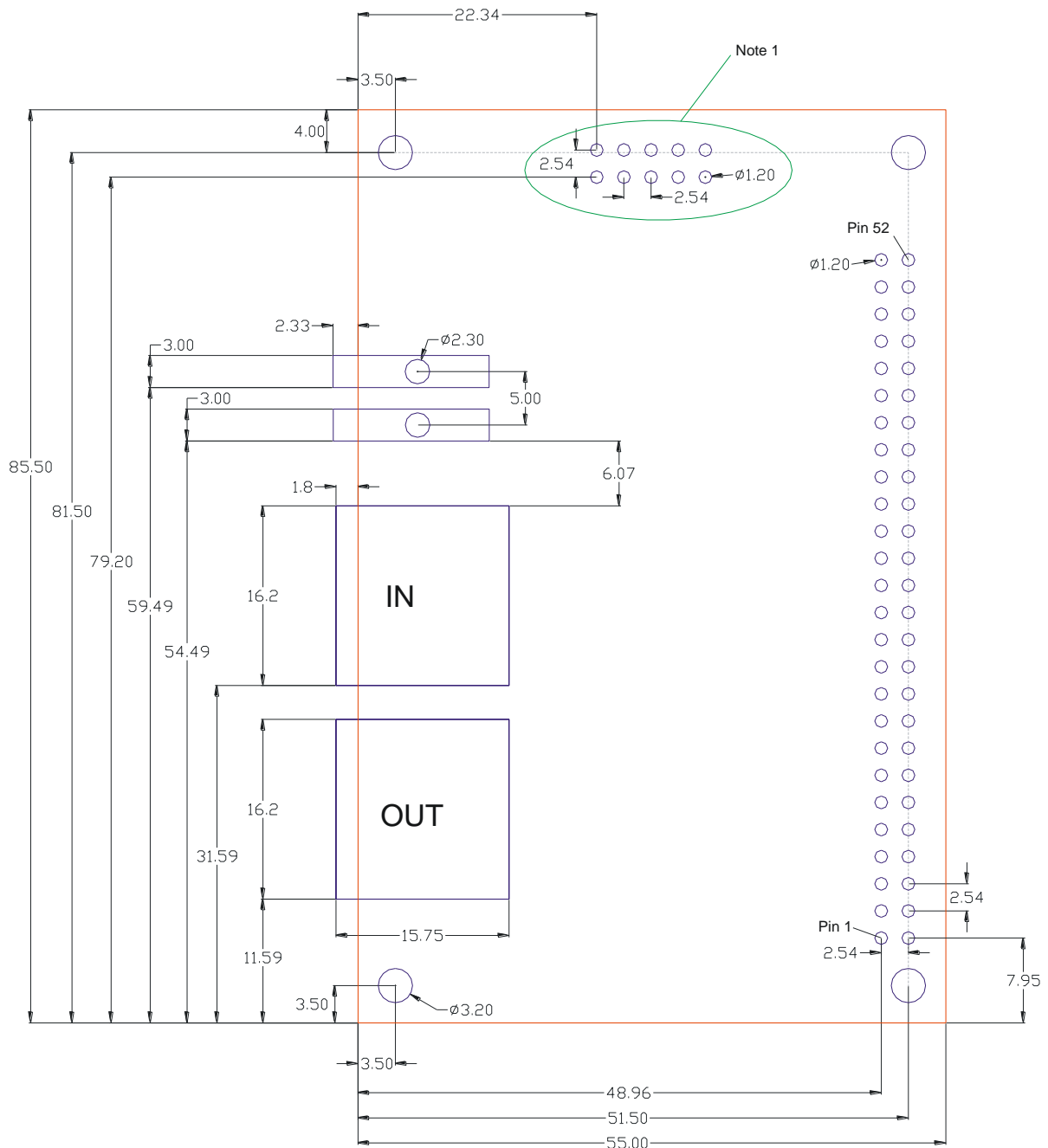

Figure 11: Board dimensions of the FB1111 – Top View



Note

The ten holes encapsulated by the ellipsoid in Figure 11 don't have to be taken into account, when the piggyback controller board is integrated into a third party customer device. The holes are only mechanical and therefore do not have any electrical connection.

7.2 Physical Connector Specification

The Board to Board connector (*CON500*) can be connected as well from the bottom as from the top side of the FB1111-014X. The bottom side low profile socket is equivalent to the *Samtec* (www.samtec.com) product with the manufacturer number CLH-126-F-D-BE-P-TR. Insertion depth from top side is 4.7 mm, respectively 3.2 mm from bottom side. A suitable pin header for the low profile socket can also be received from *Samtec*. The TSM series is suitable for the socket. As an example the pin header with the part number TSM-126-02-L-DV can be used to connect the EtherCAT piggy-back controller board FB1111-014x.

7.3 Recommended Panel Opening

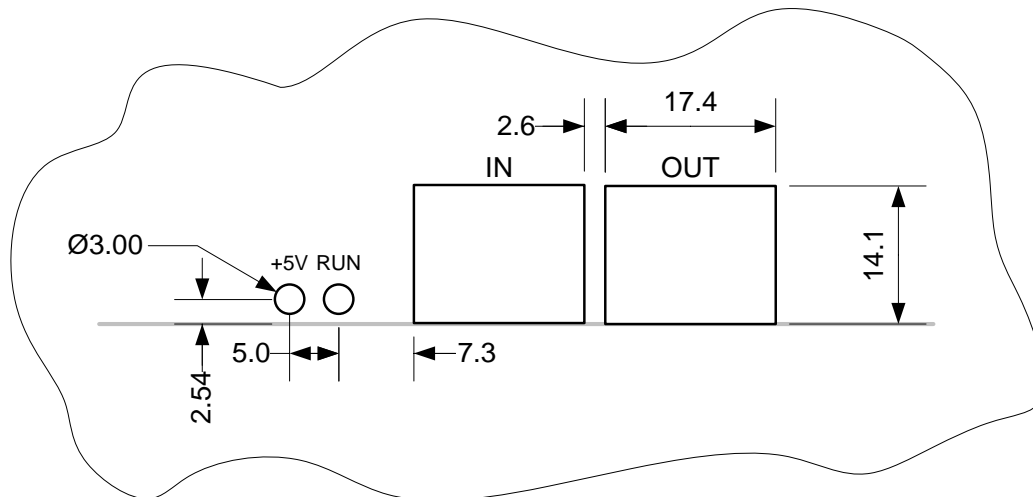

Figure 12: Recommended Panel Opening

In Figure 12 the dimensions of a typical panel opening is illustrated. The two ports and the LED break throughs have to be labelled as shown in the figure.

8 Appendix

8.1 Support and Service

Beckhoff and their partners around the world offer comprehensive support and service, making available fast and competent assistance with all questions related to Beckhoff products and system solutions.

8.1.1 Beckhoff's branch offices and representatives

Please contact your Beckhoff branch office or representative for local support and service on Beckhoff products!

The addresses of Beckhoff's branch offices and representatives round the world can be found on her internet pages: <http://www.beckhoff.com>

You will also find further documentation for Beckhoff components there.

8.2 Beckhoff Headquarters

Beckhoff Automation GmbH
Eiserstr. 5
33415 Verl
Germany

phone: + 49 (0) 5246/963-0
fax: + 49 (0) 5246/963-198
e-mail: info@beckhoff.com
web: www.beckhoff.com

Beckhoff Support

Support offers you comprehensive technical assistance, helping you not only with the application of individual Beckhoff products, but also with other, wide-ranging services:

- support
- design, programming and commissioning of complex automation systems
- and extensive training program for Beckhoff system components

hotline: + 49 (0) 5246/963-157
fax: + 49 (0) 5246/963-9157
e-mail: support@beckhoff.com

Beckhoff Service

The Beckhoff Service Center supports you in all matters of after-sales service:

- on-site service
- repair service
- spare parts service
- hotline service

hotline: + 49 (0) 5246/963-460
fax: + 49 (0) 5246/963-479
e-mail: service@beckhoff.com