

# **BECKHOFF** New Automation Technology

## Application Note

### Sample Schematic

### EtherCAT Slave Controller (ET1100 ) with 2 MII Ports (Micrel KS8721BL)

#### Page Index

- P01 : Cover Sheet (this Page)
- P02 : Revision History
- P03 : Block Diagram
- P04 : EtherCAT Slave Controller
- P05 : Ethernet PHY Port0
- P06 : Ethernet PHY Port1
- P07 : LEDs & Config
- P08 : Power/Decoupling
- P09 : Bill Of Material (BOM)

<b>BECKHOFF</b> New Automation Technology		
Eiserstr.5 33415 Verl Germany Fon: +49 5246 963-0		
Title AN_Sample_Schematic_ET1100_KS8721BL Cover Page		
Size A4	Designer	Rev 1.0
Date:	Sheet 1 of 8	

## REVISION HISTORY

DATE:	DESCRIPTION	REVISION
30.08.2007	INITIAL RELEASE	0.1
08.10.2007	U401 changed fom 32k to 16k; R401 removed; comments added for LED's.	0.2
29.01.2008	added pull-down values for the different MII configurations (Page 7)	1.0

<b>BECKHOFF</b> New Automation Technology		
Eiserstr.5 33415 Verl Germany Fon: +49 5246 963-0		
Title AN_Sample_Schematic_ET1100_KS8721BL Revision History		
Size A4	Designer	Rev 1.0
Date:		Sheet 2 of 8

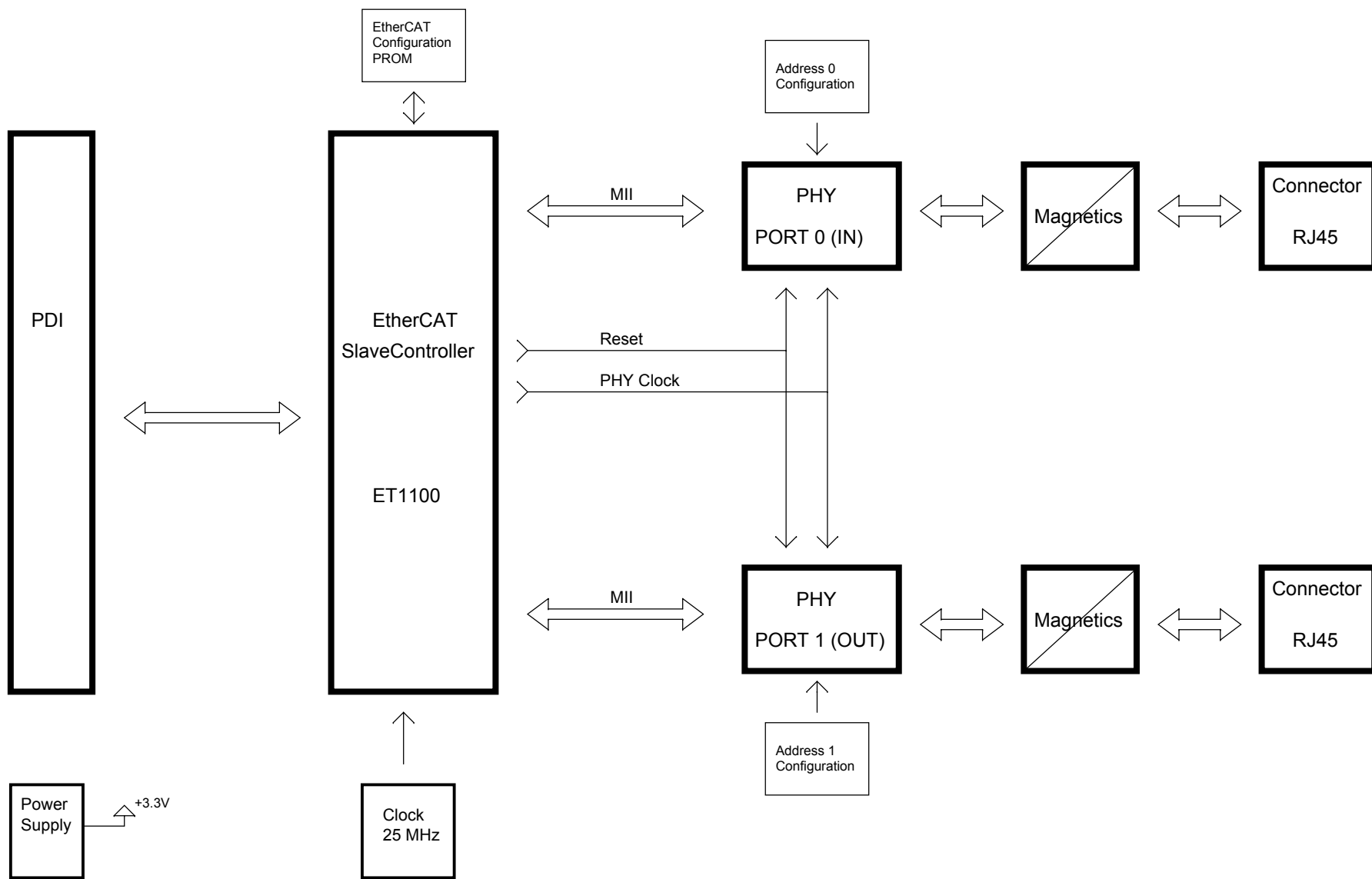



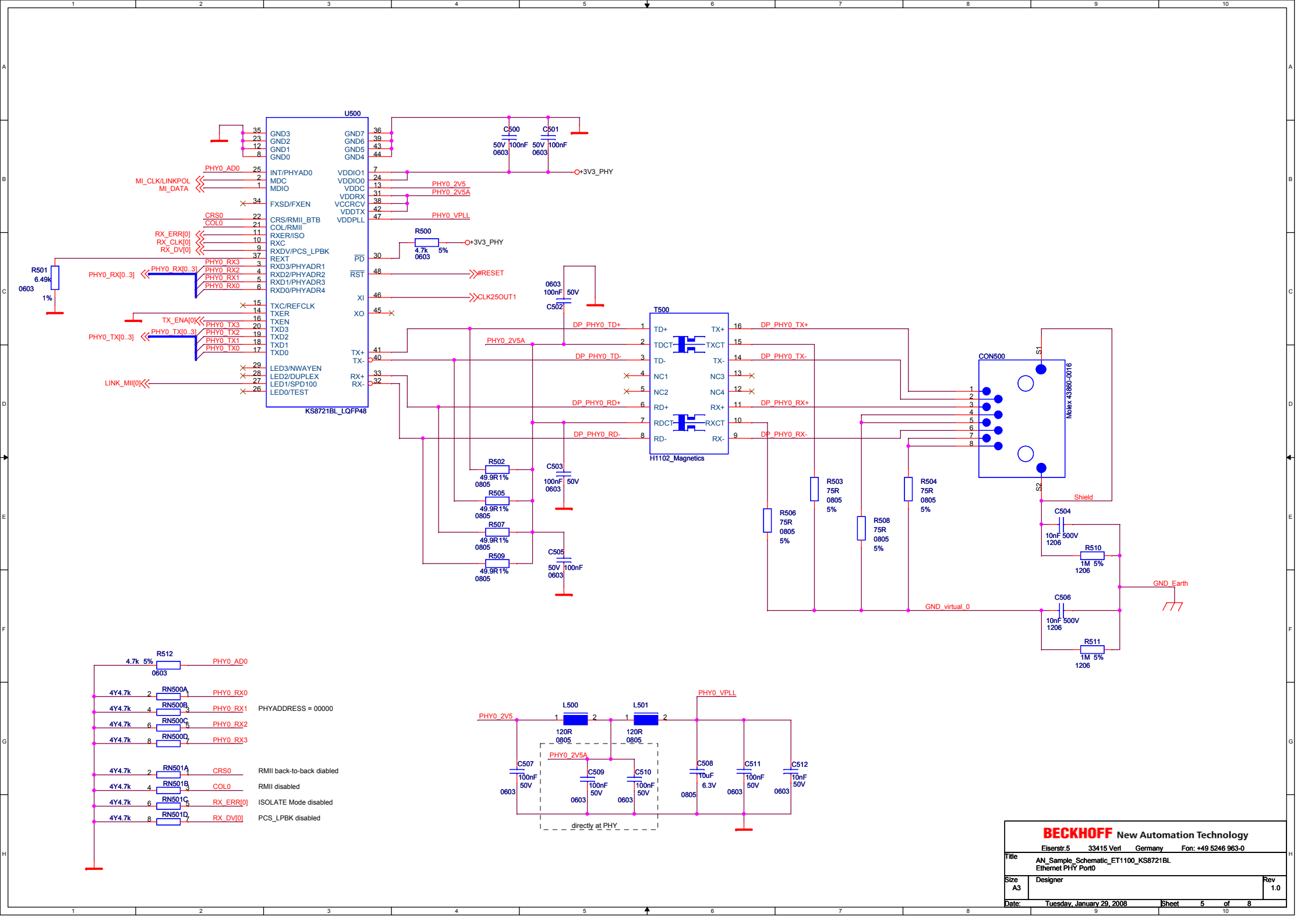

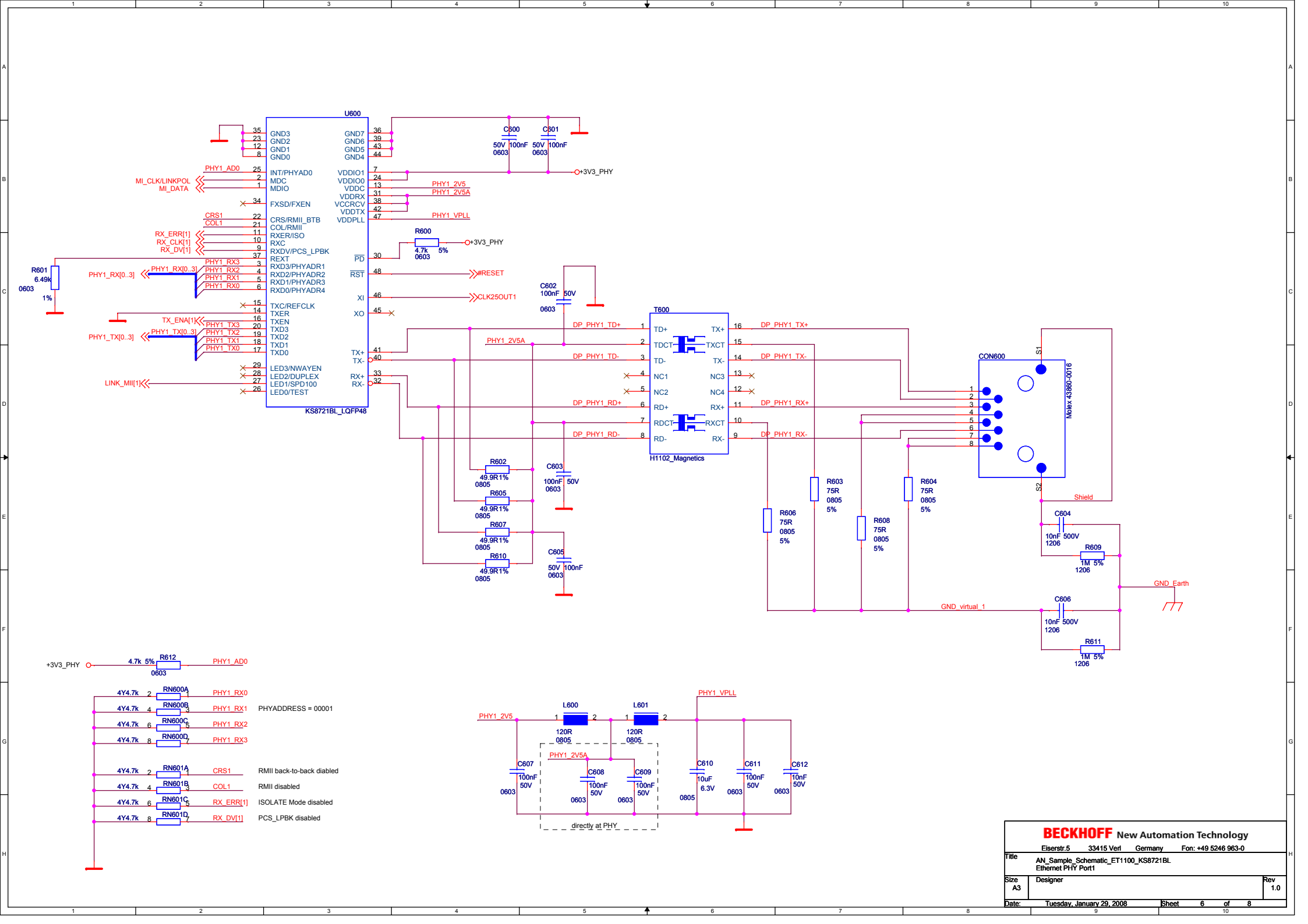

For specific PDI configuration refer to the ET1100 Datasheet and Configuration and Pinout.XLS  
[http://www.beckhoff.com/english/download/ethercat\\_development\\_products.htm](http://www.beckhoff.com/english/download/ethercat_development_products.htm)

For LEDs please refer to the EtherCAT Indicator Specification.

The Link/Activity-LED must be located either in the RJ45 connector or directly besides the connector of the IN-Port.

No LEDs have to be connected to the PHYs!

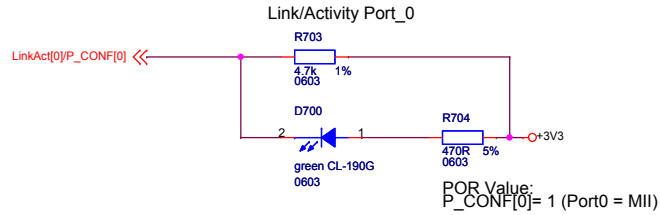

The Link/Activity-LED must be located either in the RJ45 connector or directly besides the connector of the OUT-Port.

No LEDs have to be connected to the PHYs!

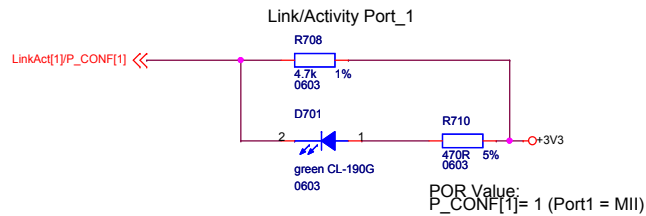

The RUN-LED shall be viewable without removing covers or parts from the devices

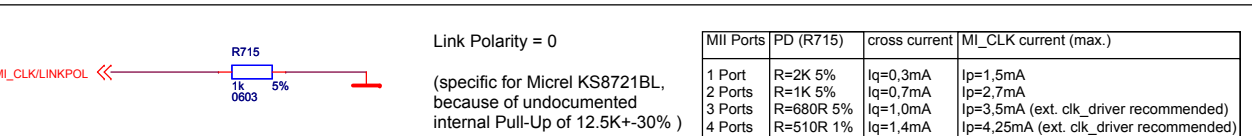
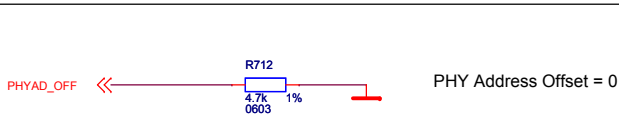
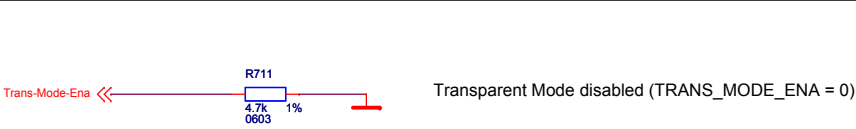
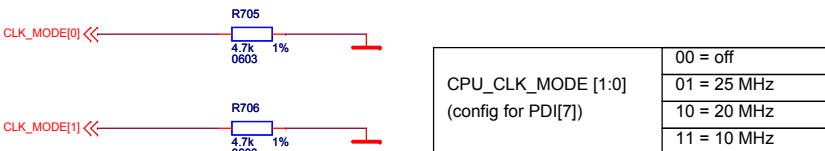
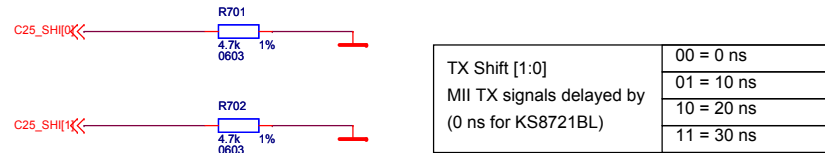
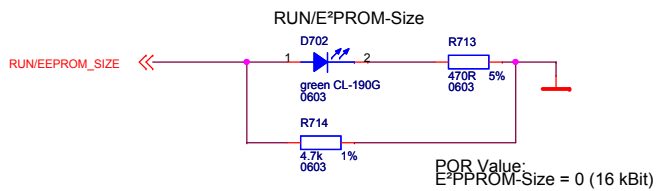

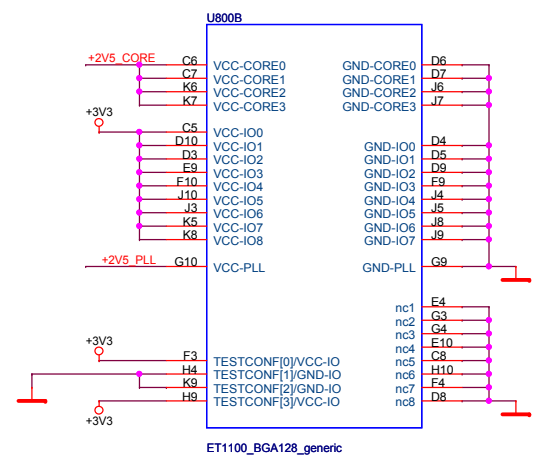
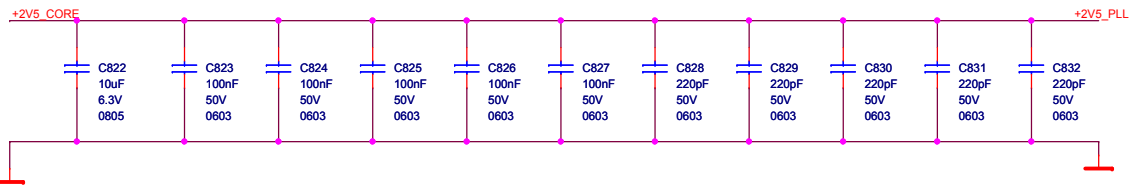
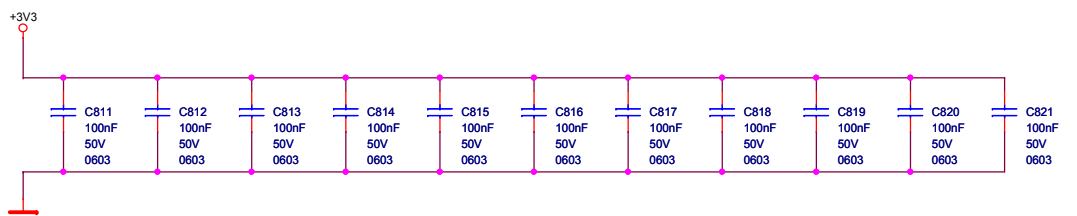
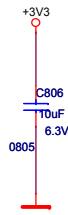
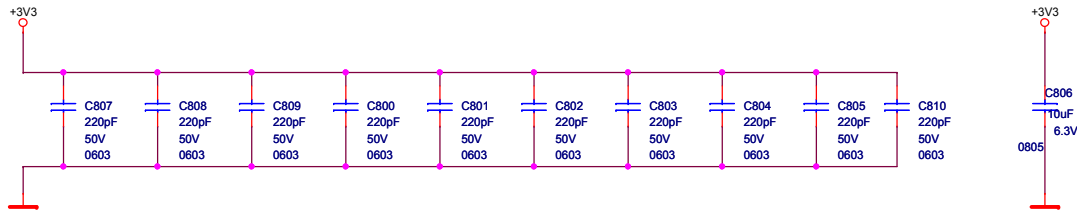

Item Number	Quantity	Value	Part Type/Description	Voltage	Part Reference
1	2	12pF	KERKO-C 12PF 0603 5% EIA-NP0	16V	C400 C401
					C500 C501 C502 C503 C505 C507 C509 C510 C511 C600 C601 C602 C603 C605 C607 C608 C609 C611 C811 C812 C813 C814 C815 C816 C817 C818 C819 C820 C821 C823 C824 C825 C826 C827
2	34	100nF	KERKO-C 100NF 0603 50V 10% EIA-X7R	50V	C504 C506 C604 C606
3	4	10nF	KERKO-C 10nF 1206 500V 10% EIA-X7R	500V	C508 C610 C806 C822
4	4	10uF	KERKO-C 10UF 0805 6V3 20% EIA-X5R	6.3V	C512 C612
5	2	10nF	KERKO-C 10NF 0603 50V 10% EIA-X7R	50V	C800 C801 C802 C803 C804 C805 C807 C808 C809 C810 C828 C829 C830 C831 C832
6	15	220pF	KERKO-C 220PF 0603 50V 20%	50V	CON500 CON600
7	2	Molex 43860-0016	BA 1x8pol RJ45 Invers Shield 2XLWL Lp-Mount Molex Nr: 43860-0016 Modular Jack		D700 D701 D702
8	3	green CL-190G	LED SMD GN 0603 SYSTEC CL-190G		L500 L501 L600 L601
9	4	120R	IND FILTER 100MHZ 120OHM SMD 0805		R400
10	1	12k	RES 12K 0603 5% 0.1W SMD		R402 R403 R700 R701 R702 R703 R705 R706 R707 R708 R709 R711 R712 R714
11	14	4.7k	RES 4K7 0603 1% 0.1W SMD		R500 R512 R600 R612
12	4	4.7k	RES 4K7 0603 5% 0.1W SMD		R501 R601
13	2	6.49k	RES 6K49 0603 1% 0.1 W SMD (E48)"79B"		R502 R505 R507 R509 R602 R605 R607 R610
14	8	49.9R	RES 49R9 0805 1% 0.1W SMD (E96)		R503 R504 R506 R508 R603 R604 R606 R608
15	8	75R	RES 75R 0805 5% 0.1W SMD (E24)		R510 R511 R609 R611
16	4	1M	RES 1M 1206 5% 0.25W SMD		R704 R710 R713
17	3	470R	RES 470R 0603 5% 0.1W SMD		R715
18	1	1k	RES 1K 0603 5% 0.1W SMD		RN500 RN501 RN600 RN601
19	4	4Y4.7k	ARRAY 4Y4K7 1206 5% 0.063W		T500 T600
20	2	H1102_Magnetics	MAGNETICS H1102 10/100BASE-T 1:1 SMD		U400 U800
21	2	ET1100_BGA128_generic	IC ET1100 BGA128 0.8 EtherCAT ASIC		U401
22	1	24LC16A_so8	IC EEPROM 2kx8 so_8 (24C16A) 2,5V-5V		U500 U600
23	2	KS8721BL_LQFP48	IC Ks8721bl Lqfp-48 Ethern.phy3v3 100/10 Micrel		X400
24	1	25MHz	QUARTZ 25MHz CPX-42 SMD (4X2.5X0.8) 4PADS		