

**BECKHOFF** New Automation Technology

Manual | EN

# VOS2000-0822

Industrial-grade high-resolution C-mount lens





# Table of contents

<b>1 Foreword</b> .....	<b>5</b>
1.1 Notes on the documentation .....	5
1.2 Safety instructions .....	6
1.3 Notes on information security.....	7
<b>2 For your safety</b> .....	<b>8</b>
2.1 Intended use .....	8
2.2 Explanation of symbols .....	8
2.3 Safety instructions .....	9
<b>3 Product overview</b> .....	<b>10</b>
3.1 Structure.....	11
3.2 Technical data.....	12
<b>4 Mounting and demounting</b> .....	<b>17</b>
4.1 Attach lens .....	17
4.2 Mount lens.....	17
4.3 Remove lens .....	18
<b>5 Use</b> .....	<b>19</b>
5.1 Focus .....	19
5.2 Closing the aperture .....	20
5.3 Attach filter .....	21
5.4 Clean lens .....	21
<b>6 Disposal</b> .....	<b>22</b>
<b>7 Appendix</b> .....	<b>23</b>
7.1 Support and Service.....	23



# 1 Foreword

## 1.1 Notes on the documentation

This description is only intended for the use of trained specialists in control and automation engineering who are familiar with applicable national standards.

It is essential that the documentation and the following notes and explanations are followed when installing and commissioning the components.

It is the duty of the technical personnel to use the documentation published at the respective time of each installation and commissioning.

The responsible staff must ensure that the application or use of the products described satisfy all the requirements for safety, including all the relevant laws, regulations, guidelines and standards.

### Disclaimer

The documentation has been prepared with care. The products described are, however, constantly under development.

We reserve the right to revise and change the documentation at any time and without prior announcement. No claims for the modification of products that have already been supplied may be made on the basis of the data, diagrams and descriptions in this documentation.

### Trademarks

Beckhoff®, TwinCAT®, TwinCAT/BSD®, TC/BSD®, EtherCAT®, EtherCAT G®, EtherCAT G10®, EtherCAT P®, Safety over EtherCAT®, TwinSAFE®, XFC®, XTS® and XPlanar® are registered trademarks of and licensed by Beckhoff Automation GmbH.

Other designations used in this publication may be trademarks whose use by third parties for their own purposes could violate the rights of the owners.

### Patent Pending

The EtherCAT Technology is covered, including but not limited to the following patent applications and patents:

EP1590927, EP1789857, EP1456722, EP2137893, DE102015105702  
with corresponding applications or registrations in various other countries.



EtherCAT® is a registered trademark and patented technology, licensed by Beckhoff Automation GmbH, Germany

### Copyright

© Beckhoff Automation GmbH & Co. KG, Germany.

The reproduction, distribution and utilization of this document as well as the communication of its contents to others without express authorization are prohibited.

Offenders will be held liable for the payment of damages. All rights reserved in the event of the grant of a patent, utility model or design.

## 1.2 Safety instructions

### Safety regulations

Please note the following safety instructions and explanations!  
Product-specific safety instructions can be found on following pages or in the areas mounting, wiring, commissioning etc.

### Exclusion of liability

All the components are supplied in particular hardware and software configurations appropriate for the application. Modifications to hardware or software configurations other than those described in the documentation are not permitted, and nullify the liability of Beckhoff Automation GmbH & Co. KG.

### Personnel qualification

This description is only intended for trained specialists in control, automation and drive engineering who are familiar with the applicable national standards.

### Description of symbols

In this documentation the following symbols are used with an accompanying safety instruction or note. The safety instructions must be read carefully and followed without fail!

#### **DANGER**

##### **Serious risk of injury!**

Failure to follow the safety instructions associated with this symbol directly endangers the life and health of persons.

#### **WARNING**

##### **Risk of injury!**

Failure to follow the safety instructions associated with this symbol endangers the life and health of persons.

#### **CAUTION**

##### **Personal injuries!**

Failure to follow the safety instructions associated with this symbol can lead to injuries to persons.

#### **NOTE**

##### **Damage to the environment or devices**

Failure to follow the instructions associated with this symbol can lead to damage to the environment or equipment.



##### **Tip or pointer**

This symbol indicates information that contributes to better understanding.

## 1.3 Notes on information security

The products of Beckhoff Automation GmbH & Co. KG (Beckhoff), insofar as they can be accessed online, are equipped with security functions that support the secure operation of plants, systems, machines and networks. Despite the security functions, the creation, implementation and constant updating of a holistic security concept for the operation are necessary to protect the respective plant, system, machine and networks against cyber threats. The products sold by Beckhoff are only part of the overall security concept. The customer is responsible for preventing unauthorized access by third parties to its equipment, systems, machines and networks. The latter should be connected to the corporate network or the Internet only if appropriate protective measures have been set up.

In addition, the recommendations from Beckhoff regarding appropriate protective measures should be observed. Further information regarding information security and industrial security can be found in our <https://www.beckhoff.com/secguide>.

Beckhoff products and solutions undergo continuous further development. This also applies to security functions. In light of this continuous further development, Beckhoff expressly recommends that the products are kept up to date at all times and that updates are installed for the products once they have been made available. Using outdated or unsupported product versions can increase the risk of cyber threats.

To stay informed about information security for Beckhoff products, subscribe to the RSS feed at <https://www.beckhoff.com/secinfo>.

## 2 For your safety

Read the chapter on safety and follow the instructions in order to protect from personal injury and damage to equipment.

### Disclaimer

All the components are supplied in particular hardware and software configurations appropriate for the application. Modifications to hardware or software configurations other than those described in the documentation are not permitted, and nullify the liability of Beckhoff Automation GmbH.

### Personnel qualification

This description is only intended for the use of trained specialists in control, automation and drive engineering who are familiar with the applicable national standards.

## 2.1 Intended use

The VOS2000-0822 lens is intended for use in industry, specifically for use in machine vision in manufacturing and production processes. It serves here as a lens system for inspection tasks, measurement and defect detection.

The VOS2000-0822 lens

- is suitable for continuous operation.
- is only suitable for storage in a temperature range of -10 °C to 60 °C.
- is only suitable for use in a temperature range from 0 °C to 60 °C.
- is only suitable for use at a relative humidity of 20 to 70 percent.

Intended use also includes compliance with all specifications in the documentation. Any use beyond the intended use or any other use is considered misuse.

### Possible misuse

- Use outside the specified environmental parameters.
- Any kind of modifications.

In case of misuse, liability for damages of any kind is excluded.

## 2.2 Explanation of symbols

In this documentation the following symbols are used with an accompanying safety instruction or note. The safety instructions must be read carefully and followed without fail.

### WARNING

#### **Risk of injury!**

Failure to follow the safety instructions associated with this symbol endangers the life and health of persons!

### CAUTION

#### **Personal injuries!**

Failure to follow the safety instructions associated with this symbol can lead to injuries to persons!



**NOTE****Damage to the environment or devices**

Failure to follow the instructions associated with this symbol can lead to damage to the environment or equipment.

**Tip or pointer**

This symbol indicates information that helps in handling the product.

## 2.3 Safety instructions

The following safety instructions must be observed when handling the VOS2000-0822 lens.

**Application conditions**

- Never leave the lens in the sun or point it directly at the sun. This can cause smoke or fires.
- Keep the sun out of the image field when taking backlit shots. There is a risk of fire.
- Never look directly at the sun or bright light through the lens. This can permanently impair vision or lead to blindness.
- Do not leave the lens in the sun or under bright light. Such strong thermal stress can cause internal malfunctions in the lens.
- Avoid stains and dust on the lens, otherwise image processing errors may occur. Always change the lens quickly and in a dust-free environment.
- Damage may result in sharp-edged glass splinters. There is a risk of injury.
- Observe the maximum torque when tightening the screws.

**Transport and storage**

- Sudden temperature changes can cause condensation on or in the lens. Store the lens in an airtight bag before moving it to a much warmer or colder location. Unpack the lens as soon as it has adjusted to the new temperature.
- Mold may form if the lens is stored in a humid environment. If you do not use the lens for a long time, store it in a cool and dry place.
- When storing the lens, always attach the lens caps to prevent dust formation. Also, remove any dust from the lens caps before attaching them.

### 3 Product overview

With its robust and easy-to-mount design, the **VOS2000-0822** C-mount lens is ideal for use in harsh industrial automation environments. In addition to being straightforward to adjust, the focus and fixed aperture can be locked easily and precisely using compact screws. The broadband anti-reflection coating ranges from 420 nm to 1050 nm, while the vibration resistance facilitates reliable measurements in the visible and near infrared regions. The lens is suitable for camera sensors up to a format of 2/3" and has a focal length of 8 mm. The f-number is adjustable from 2.2 to 16.

#### VOS2000 series

VOS2000-0625	<b>VOS2000-0822</b>	VOS2000-1218	VOS2000-1616	VOS2000-2516	VOS2000-3522	VOS2000-5028
--------------	---------------------	--------------	--------------	--------------	--------------	--------------

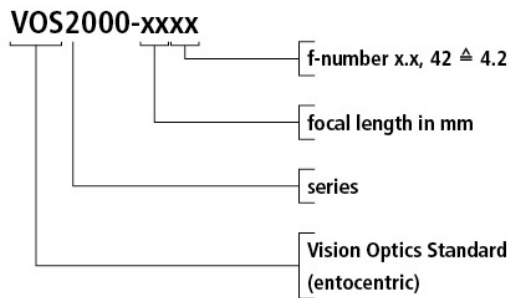

Fig. 1: VOS2000 nomenclature

#### Beckhoff Traceability Number (BTN)

Each VOS2000 lens has a unique **Beckhoff Traceability Number (BTN)** on the "Beckhoff" ring.

#### Areas of application

VOS2000 series lenses are mainly used for the following applications:

- Presence and placement checking
- Pick-and-place application
- Print image inspection
- Color application
- OCR
- Barcode recognition

### 3.1 Structure

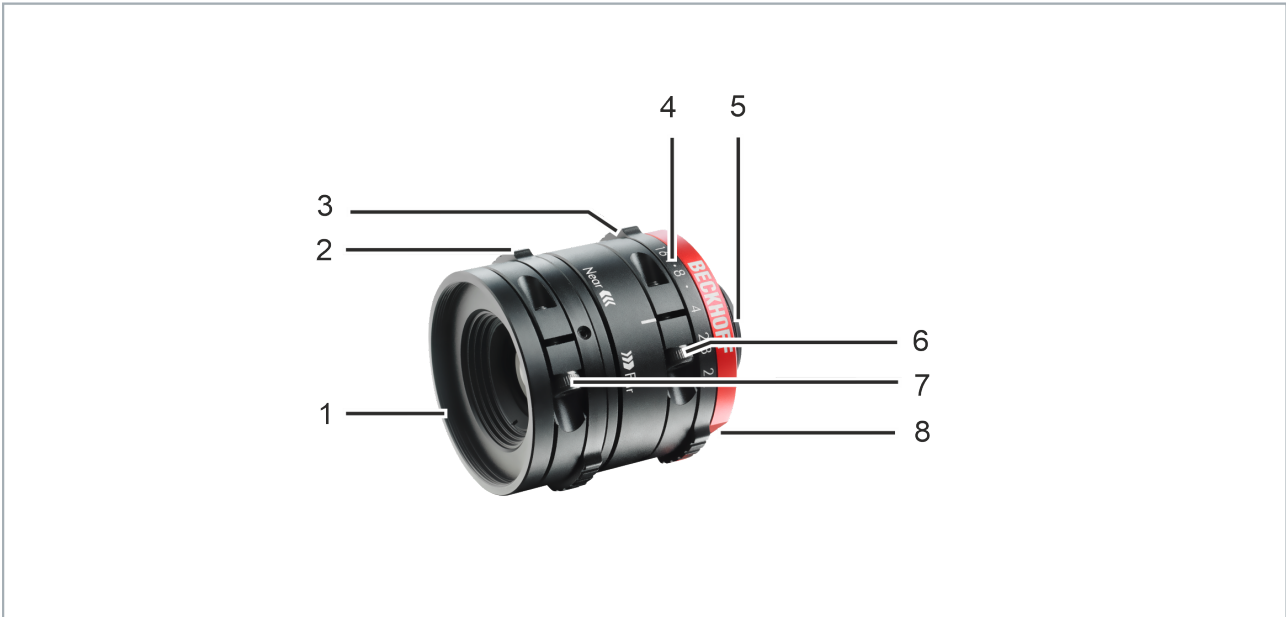

Fig. 2: VOS2000-0822 structure

Number	Part identification
1	Filter thread
2	Focusing ring
3	Aperture ring
4	Aperture scale
5	C-mount connection
6	Locking screw for the aperture ring
7	Locking screw for the focusing ring
8	"Beckhoff" ring

## 3.2 Technical data

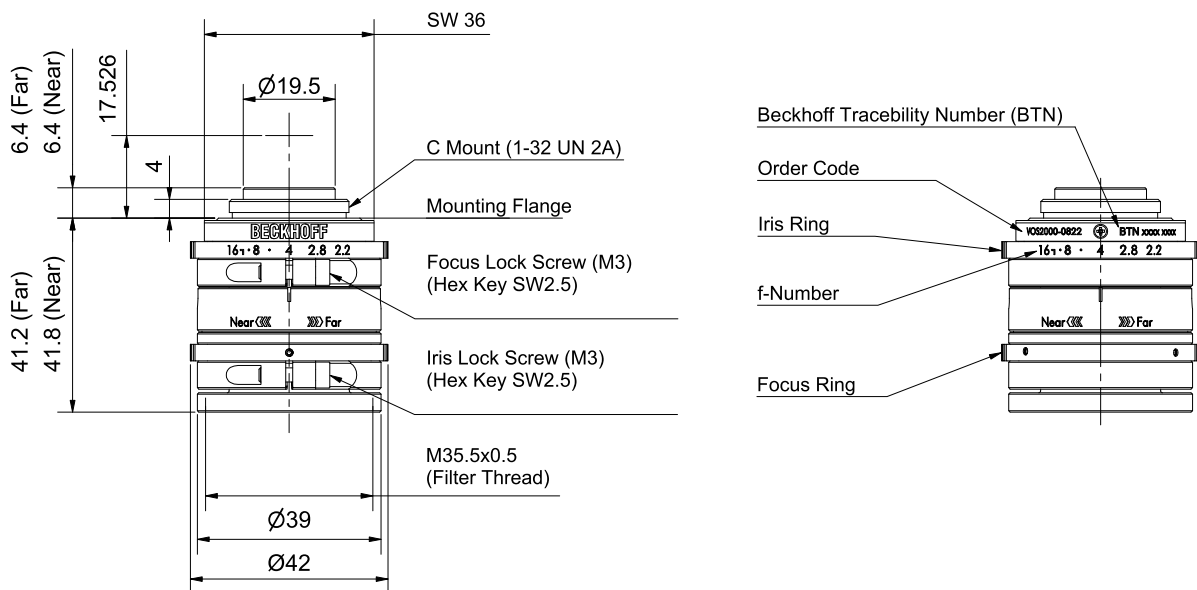

Fig. 3: Technical drawing

Mechanical data	Value
Total length (near - far) (mm)	47.6 ... 48.2
Length from lens shoulder (mm)	41.2 ... 41.8
Weight (g)	130
Diameter (mm)	42
Connection	C-mount
Filter thread	M35.5x0.5

Environmental conditions	Value
Vibration resistance <sup>1</sup> (G)	10
Operating temperature <sup>2</sup> (°C)	0 ... 60
Storage temperature <sup>3</sup> (°C)	-10 ... 60

<sup>1</sup> according to JISC60068-2-6 Freq. 10 - 150 [Hz], Test time: X,Y,X axis direction 20 cycles / 8 min total 160 min x 3 = 480 min.

<sup>2</sup> relative humidity 20 ... 70%, non-condensing

<sup>3</sup> non-condensing

Optical data	Symbol	Nominal object distance	Minimum object distance
Working distance (mm)		500	100
Object distance <sup>1</sup> (mm)	$s$	504.0	104.0
Focal length (mm)	$f, f'$	8.2	7.9
Object-side focal length (mm)	$s_F$	-8.05	-8.19
Image-side focal length (mm)	$s'_F$	11.87	11.87
Back focal length of the object-side principal plane (mm)	$s_H$	16.2	16.1
Back focal length of the image-side principal plane (mm)	$s'_H$	-3.60	-3.50
Interstitium (mm)	$i$	27.36	26.72
Distance from object to image (mm)		555.84	155.29
Object distance (mm)	$a$	520.2	120.1
Image distance (mm)	$a'$	8.3	8.5
f-number		2.2 ... 16.0	
Back focal length of the entrance pupil (mm)	$s_{EP}$	10.6	10.6
Back focal length of the exit pupil (mm)	$s'_{AP}$	14.3	14.3
Diameter of the entrance pupil (mm)		3.70	3.70
Diameter of the exit pupil (mm)		11.90	11.90
Angle of view <sup>2</sup> (degrees)	$\omega_{max}$	68.03	69.62
Lateral magnification	$\beta'$	0.016	0.071
Distortion (%)		-1.80	-1.85
Depth of field <sup>3</sup> (mm)		720.2	36.5
Resolution <sup>4</sup> ( $\mu\text{m}$ )		2	
Relative illumination (%)		27.94	27.89
Image circle diameter (mm)		11	
Sensor size (inch)		2/3	
Flange focal length (mm)	$A_O$	17.526	
Distance between object-side principal plane and lens shoulder (mm)	$H_A$	18.11	17.66
Available spectral range (nm)		420 ... 1050	

<sup>1</sup> identical with the *object distance* according to DIN 1335:2003-12

<sup>2</sup> identical with the double *object field angle* according to DIN 1335:2003-12

<sup>3</sup> at a circle of confusion diameter of 0.04 mm

<sup>4</sup> at 550 nm

**Explanation of symbols**

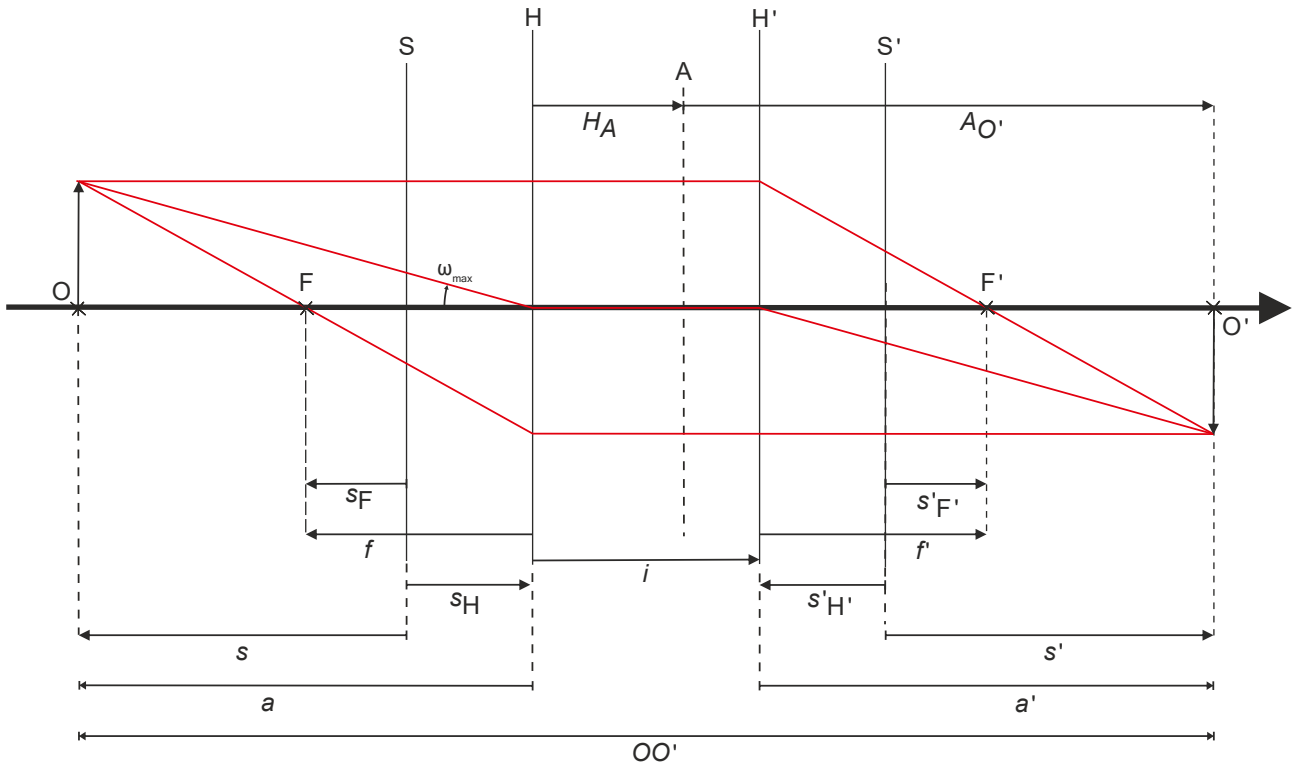
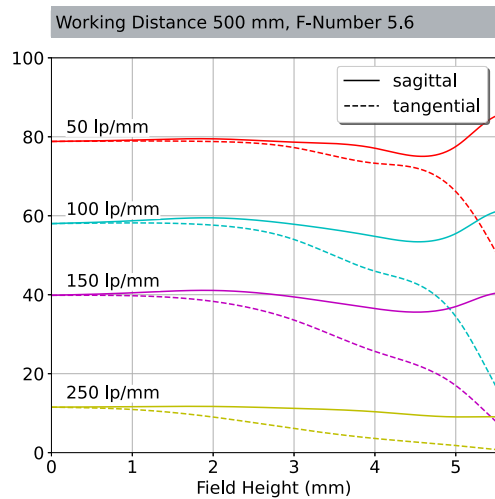
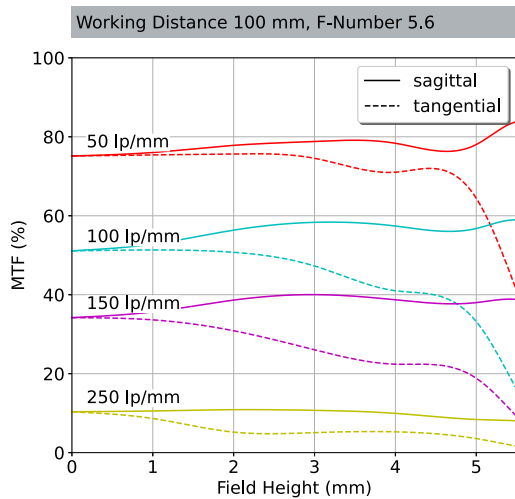
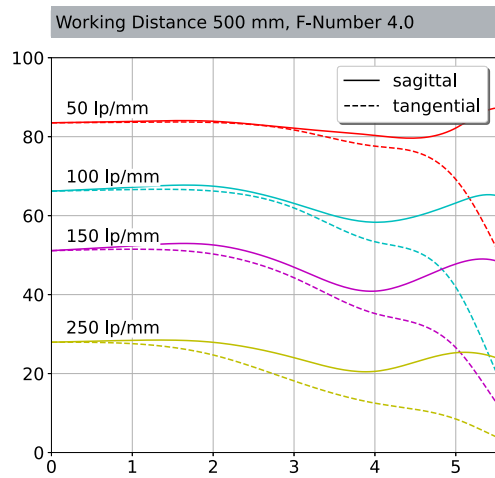
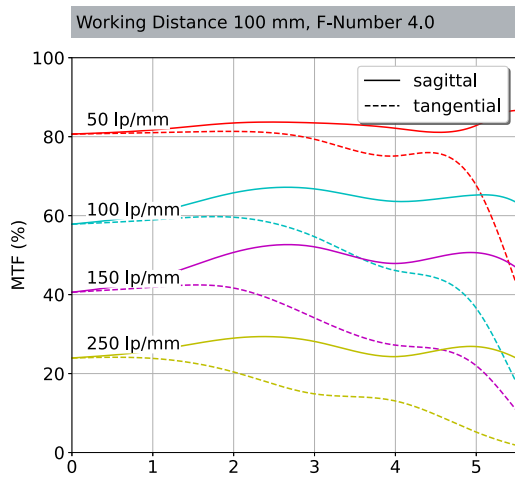
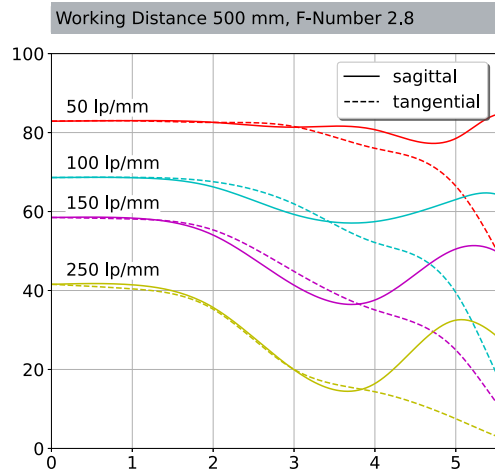
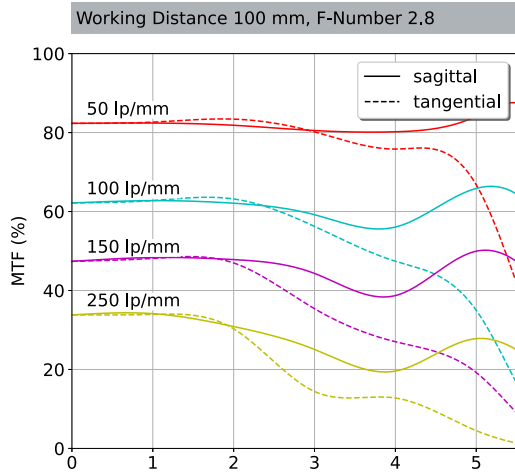

Fig. 4: Geometric optics

- |  |   |
|--|---|
| <b>O</b> Axis point of the object  | <b>O'</b> Axis point of the image   |
| <b>F</b> object-side focal point   | <b>F'</b> image-side focal point  |
| <b>S</b> first vertex  | <b>S'</b> last vertex   |
| <b>H</b> object-side principal point   | <b>H'</b> image-side principal point                                      |
| <b>A</b> Lens shoulder   | <b>A<sub>O'</sub></b> Flange focal length                                 |
| <b>s<sub>F</sub></b> object-side back focal length                                     | <b>s'<sub>F</sub></b> image-side back focal length                        |
| <b>f</b> object-side focal length  | <b>f'</b> image-side focal length   |
| <b>s<sub>H</sub></b> Back focal length of the object-side principal point              | <b>s'<sub>H</sub></b> Back focal length of the image-side principal point |
| <b>s</b> Object distance   | <b>s'</b> Flange focal length   |
| <b>a</b> Object distance   | <b>a'</b> Image distance  |
| <b>H<sub>A</sub></b> Distance of the object-side principal point to the flange surface | <b>i</b> Interstitium   |
| <b>ω<sub>max</sub></b> object-side field angle   | <b>OO'</b> Distance of the axis points of object and image                |

**Note:** directional routes are indicated by arrows with an arrowhead.

Modulation transfer functions (MTF)



**Distortion**

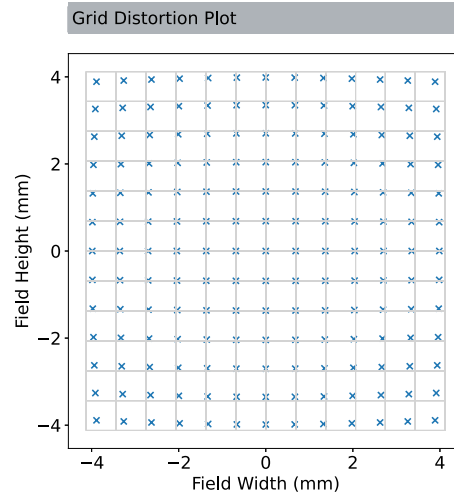
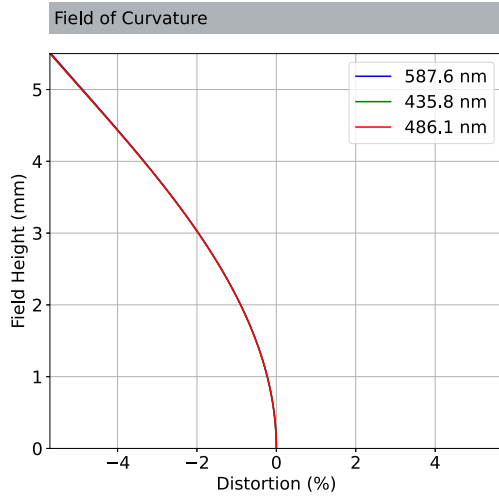

**Relative illumination**

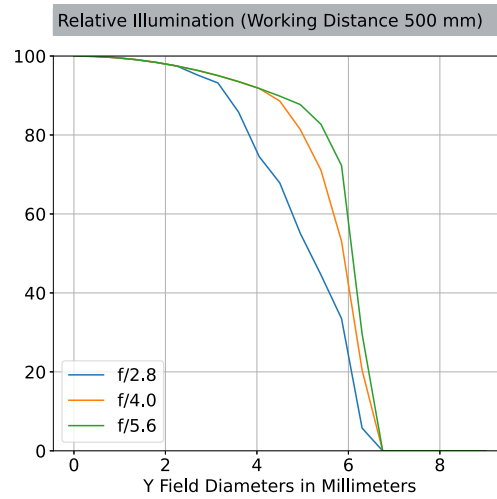
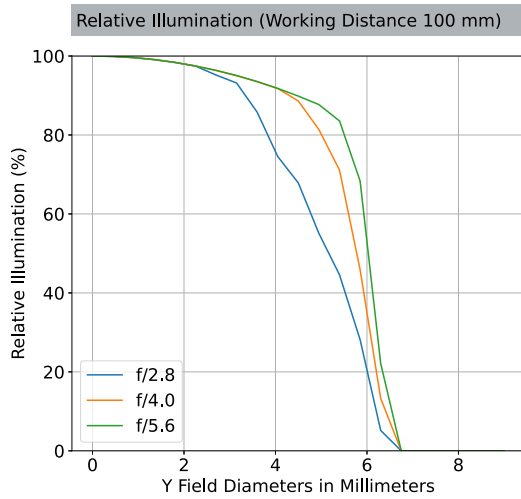

**Transmission**

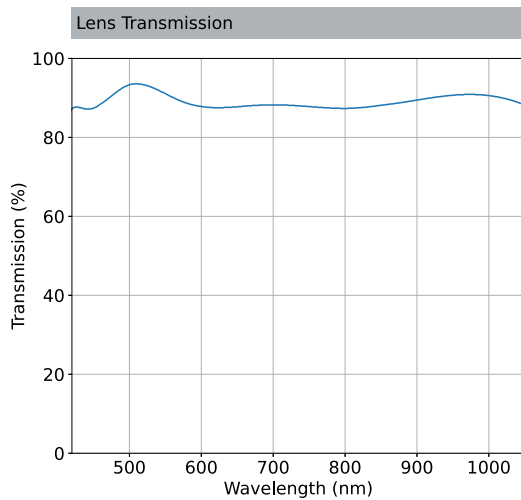



## 4 Mounting and demounting

### 4.1 Attach lens

The lens can be attached to cameras with C-mount connection.

1. Turn off the camera.
2. Remove the housing cover from the camera.
3. Remove the rear lens cap from the lens.
4. Place the thread of the lens on the C-mount camera.
5. Turn the lens clockwise until it is firmly seated.

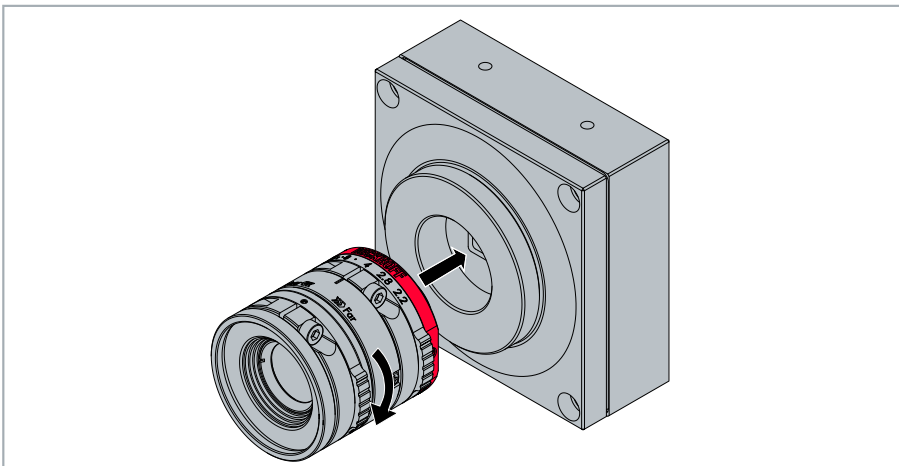

Fig. 5: Attach lens

6. Remove the front lens cap from the lens.  
⇒ The lens is now firmly attached to the camera and ready for use.

### 4.2 Mount lens

For example, the lens can be additionally fixed for high vibration applications.

- ✓ A wrench is required. The recommended torque is 100 N \* cm and the maximum torque is 150 N \* cm.
1. Place the wrench on the edges of the "Beckhoff" ring.
  2. To tighten the lens, turn the "Beckhoff" ring clockwise.

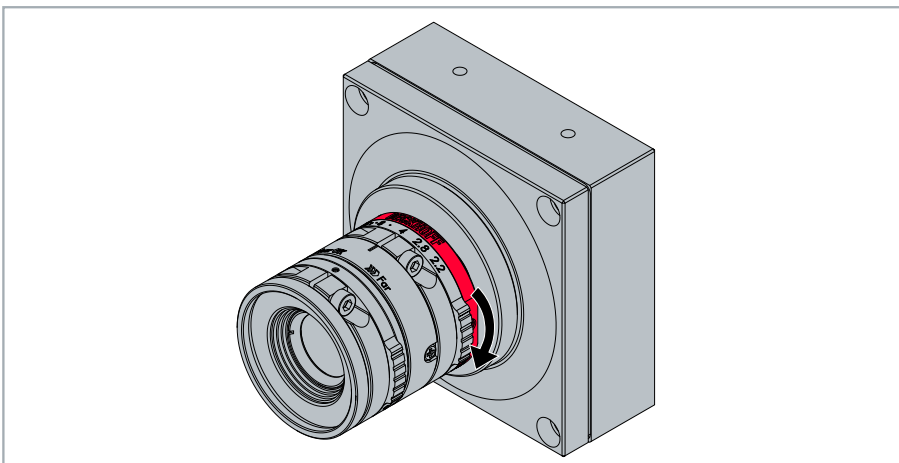

Fig. 6: Tighten lens

⇒ The lens is now firmly attached to the camera.

## 4.3 Remove lens

If necessary, the lens can be removed from the camera.

1. Turn off the camera.
2. Attach the front lens cap to the lens.
3. Turn the lens counterclockwise until it can be detached from the camera.

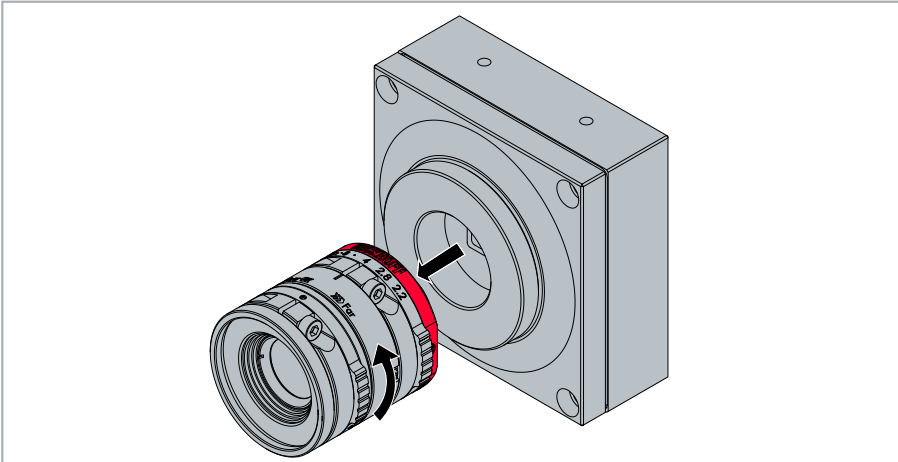

Fig. 7: Remove lens

4. Attach the rear lens cap to the lens.
- ⇒ The lens can now be stored or attached to another camera.

## 5 Use

The image sharpness can be adjusted with the focusing ring.

The aperture can be adjusted using the aperture ring.

Both clamping rings are freely rotatable and can be fixed in any position.

### 5.1 Focus

The image sharpness can be adjusted with the focusing ring. The focusing ring can be loosened or locked using the locking screw. The smallest distance between the object and the lens at which the lens can still focus is 100 mm.

✓ An M3 Allen key is required for the locking screw. The recommended torque for M3 screws is 50 N \* cm.

1. Loosen the locking screw for the focusing ring using an M3 Allen key.

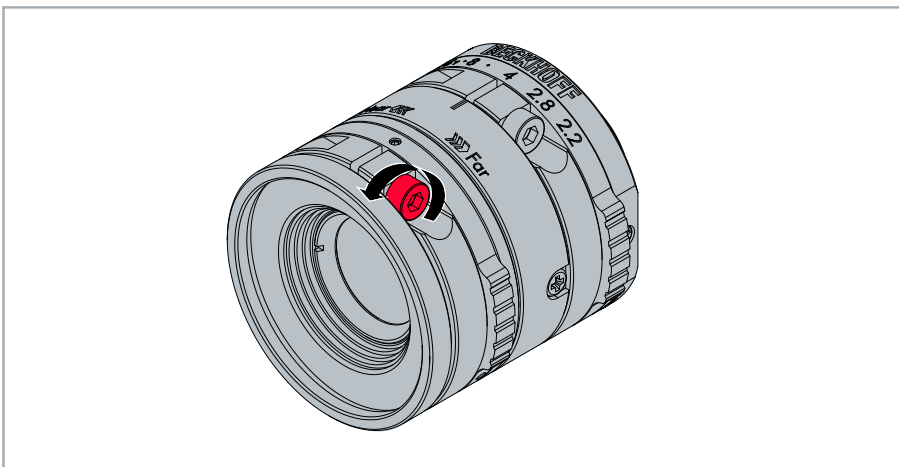

Fig. 8: Loosen focusing screw

2. To focus the image, turn the focusing ring.

3. To obtain a sharp image at a short working distance, turn the focusing ring in the direction of the "Near" label. To obtain a sharp image at a long working distance, turn the focusing ring in the direction of the "Far" label.

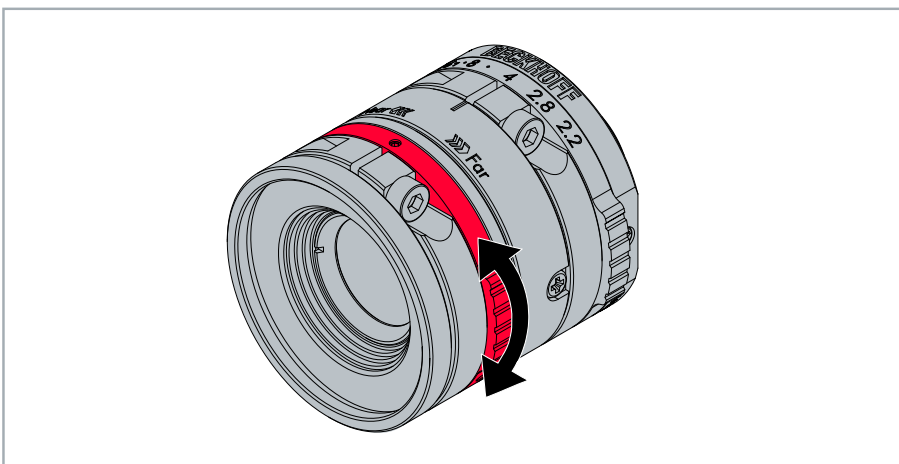

Fig. 9: Turn focusing ring

4. Fix the focusing ring in the desired position by tightening the focusing ring locking screw with an M3 Allen key.

⇒ The set focus is now fixed.

### ● Refocus

**i**

The set focus may be lost in the event of major temperature changes.

- Adjust the focus manually again.

### ● Loss of contrast and sharpness

**i**

Inaccurate focusing can cause both contrast and sharpness to be lost. This can affect the imaging performance of the system.

- Set the focus as precisely as possible.

**Exception:** Distracting object features or structures should be suppressed in favor of homogenization through blurring.

### ● Focusing with open aperture

**i**

At open aperture, the depth of field decreases. Therefore, the focus can best be adjusted with the aperture wide open. After that, the aperture can be closed more again.

- Open the aperture and adjust the focus.

## 5.2 Closing the aperture

The aperture can be opened or closed with the aperture ring. The aperture ring can be loosened or locked via the locking screw.

You can choose between f-numbers 2,2 and 16. The smaller the f-number, the larger the aperture. Conversely, the higher the f-number, the smaller the aperture. Thus, the largest aperture is achieved with the smallest f-number and the smallest aperture with the highest f-number.

The wider the aperture opening, the brighter the image and the smaller the depth of field. Smaller f-numbers reduce the depth of field.

✓ An M3 Allen key is required for the locking screw. The recommended torque for M3 screws is 50 N \* cm.

1. Loosen the locking screw for the aperture ring using an M3 Allen key.

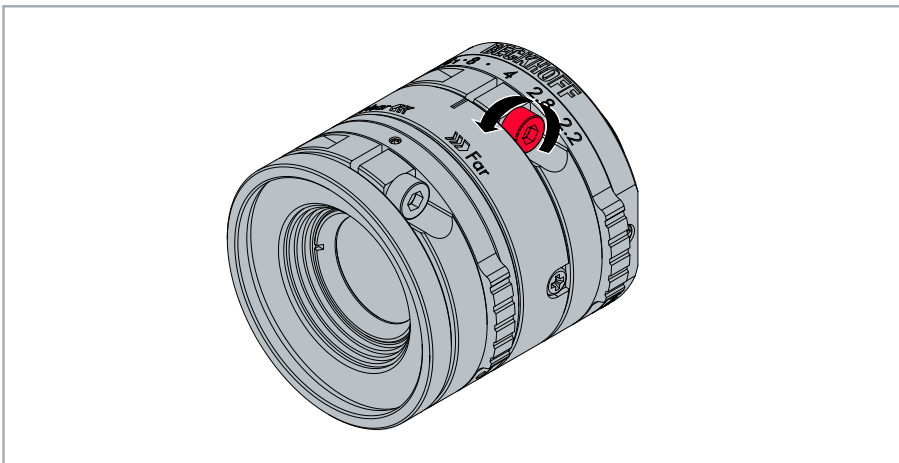

Fig. 10: Loosen aperture screw

2. To adjust the aperture, turn the aperture ring. If you turn the aperture ring clockwise as seen from the camera, the aperture becomes larger and the image brighter. If you turn counterclockwise, the aperture becomes smaller and the image darker.

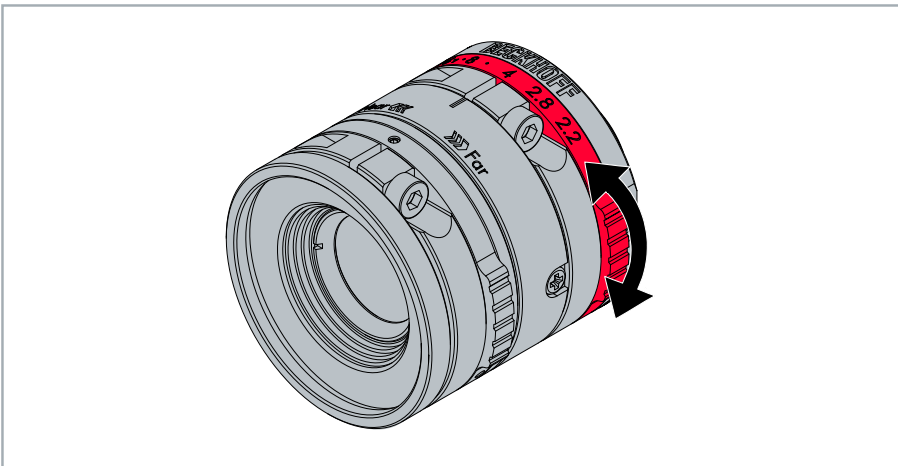

Fig. 11: Rotate aperture ring

3. Fix the aperture in the desired position by tightening the locking screw for the aperture ring with an M3 Allen key.  
⇒ The set aperture stop is now fixed.

## 5.3 Attach filter

Various filters can be attached to the lens to emphasize certain image information. To do this, screw the desired filter into the M35.5 filter thread of the lens.

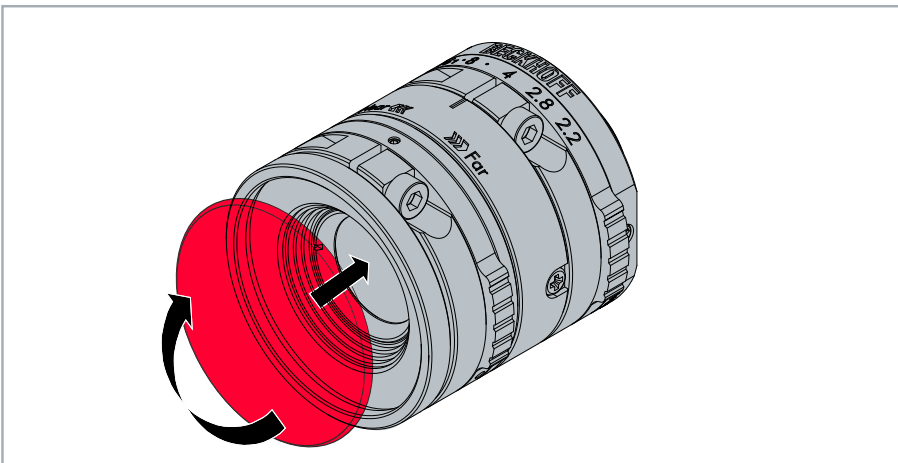

Fig. 12: Screw on filter



### Information loss

The application of a filter is accompanied by a loss of information.

## 5.4 Clean lens

Clean the lens with a soft brush, a bellows or a lint-free cloth.

## 6 Disposal

Beckhoff Automation products are marketed exclusively in the corporate business. It is therefore not necessary to mark the products with the symbol of Annex 3 of the ElektroG. In accordance with the 2012/19/EU "WEEE" directives, you can return used devices and accessories for professional disposal. The transport costs are borne by the sender.

Send the used devices with the note "For disposal" to:

Beckhoff Automation GmbH & Co. KG

Building "Service"

Stahlstraße 31

D-33415 Verl

## 7 Appendix

### 7.1 Support and Service

Beckhoff and their partners around the world offer comprehensive support and service, making available fast and competent assistance with all questions related to Beckhoff products and system solutions.

#### Beckhoff's branch offices and representatives

Please contact your Beckhoff branch office or representative for local support and service on Beckhoff products!

The addresses of Beckhoff's branch offices and representatives round the world can be found on her internet pages: <https://www.beckhoff.com>

You will also find further documentation for Beckhoff components there.

#### Beckhoff Support

Support offers you comprehensive technical assistance, helping you not only with the application of individual Beckhoff products, but also with other, wide-ranging services:

- support
- design, programming and commissioning of complex automation systems
- and extensive training program for Beckhoff system components

Hotline: +49 5246 963 157  
Fax: +49 5246 963 9157  
e-mail: [support@beckhoff.com](mailto:support@beckhoff.com)

#### Beckhoff Service

The Beckhoff Service Center supports you in all matters of after-sales service:

- on-site service
- repair service
- spare parts service
- hotline service

Hotline: +49 5246 963 460  
Fax: +49 5246 963 479  
e-mail: [service@beckhoff.com](mailto:service@beckhoff.com)

#### Beckhoff Headquarters

Beckhoff Automation GmbH & Co. KG

Huelshorstweg 20  
33415 Verl  
Germany

Phone: +49 5246 963 0  
Fax: +49 5246 963 198  
e-mail: [info@beckhoff.com](mailto:info@beckhoff.com)  
web: <https://www.beckhoff.com>





More Information:  
[www.beckhoff.com/VOS2000-0822](http://www.beckhoff.com/VOS2000-0822)

Beckhoff Automation GmbH & Co. KG  
Hülshorstweg 20  
33415 Verl  
Germany  
Phone: +49 5246 9630  
[info@beckhoff.com](mailto:info@beckhoff.com)  
[www.beckhoff.com](http://www.beckhoff.com)

