

Manual | EN

CP6500-2000-0100

Industrial PC



Table of contents

1	Notes on the documentation	5
2	For your safety	6
2.1	Signal words	6
2.2	Intended use	6
2.3	Fundamental safety instructions	7
2.4	Operator's obligation to exercise diligence	7
2.5	Notes on information security	8
3	Product overview	9
3.1	Structure	10
3.2	Interface description	11
3.2.1	Power supply	11
3.2.2	PS/2	12
3.2.3	USB	12
3.2.4	Ethernet RJ45	14
3.2.5	DVI	15
3.2.6	RS232	15
3.2.7	DisplayPort	15
3.2.8	Audio connections	17
3.3	Status LEDs	17
3.4	Name plate	18
4	Commissioning	19
4.1	Transport and unpacking	19
4.2	Control cabinet installation	20
4.3	Connecting the industrial PC	23
4.3.1	Mounting power supply cable	23
4.3.2	Grounding of the industrial PC	25
4.3.3	Connecting cables and power supply	26
4.4	Switching the industrial PC on and off	28
5	Beckhoff Device Manager	30
6	Decommissioning	32
6.1	Disconnecting the power supply and cables	32
6.2	Disassembly and disposal	33
7	Maintenance	34
7.1	Cleaning	34
7.2	Maintenance	35
7.2.1	Replacing the battery	37
7.2.2	Replacing the storage media	38
7.2.3	Replacing the fan	38
8	Troubleshooting	42
9	Technical data	43
10	Appendix	44
10.1	Service and support	44

10.2 Approvals 45

1 Notes on the documentation

This description is intended exclusively for trained specialists in control and automation technology who are familiar with the applicable national standards.

The documentation and the following notes and explanations must be complied with when installing and commissioning the components.

The trained specialists must always use the current valid documentation.

The trained specialists must ensure that the application and use of the products described is in line with all safety requirements, including all relevant laws, regulations, guidelines, and standards.

Disclaimer

The documentation has been compiled with care. The products described are, however, constantly under development.

We reserve the right to revise and change the documentation at any time and without notice.

Claims to modify products that have already been supplied may not be made on the basis of the data, diagrams, and descriptions in this documentation.

Trademarks

Beckhoff®, TwinCAT®, TwinCAT/BSD®, TC/BSD®, EtherCAT®, EtherCAT G®, EtherCAT G10®, EtherCAT P®, Safety over EtherCAT®, TwinSAFE®, XFC®, XTS®, and XPlanar® are registered and licensed trademarks of Beckhoff Automation GmbH.

If third parties make use of the designations or trademarks contained in this publication for their own purposes, this could infringe upon the rights of the owners of the said designations.



EtherCAT® is a registered trademark and patented technology, licensed by Beckhoff Automation GmbH, Germany

Copyright

© Beckhoff Automation GmbH & Co. KG, Germany.

The distribution and reproduction of this document, as well as the use and communication of its contents without express authorization, are prohibited.

Offenders will be held liable for the payment of damages. All rights reserved in the event that a patent, utility model, or design are registered.

Third-party trademarks

Trademarks of third parties may be used in this documentation. You can find the trademark notices here: <https://www.beckhoff.com/trademarks>.

2 For your safety

The signal words and their meanings are explained in the chapter on safety. They contain fundamental safety instructions that are essential for preventing personal injuries and damage to property.

Exclusion of liability

Beckhoff shall not be held liable in the event that this documentation is not complied with and the devices are therefore not used in line with the documented operating conditions.

2.1 Signal words

The signal words used in the documentation are classified below.

Warning on personal injuries

⚠ DANGER
High-risk hazard that will result in death or serious injury.
⚠ WARNING
Medium-risk hazard that may result in death or serious injury.
⚠ CAUTION
Low-risk hazard that may result in minor injury.

Warning on property and environmental damage

NOTICE
The environment, equipment, or data may be damaged.

2.2 Intended use

The device is intended for use as a control system for automation, visualization and communication in machine and system engineering.

The device has been developed for an IP20 working environment. This involves finger protection and protection against solid foreign objects up to 12.5 mm. There is no protection against water. Operation of the devices in wet and dusty environments is not permitted.

The specified limits for technical data must be adhered to.

The device can be used within the documented operating conditions.

Improper use

Do not use the device outside the documented operating conditions.

2.3 Fundamental safety instructions

The following safety instructions must be observed when handling the device.

Application conditions

- Do not use the device under extreme environmental conditions.
- Only use the device in hazardous areas if it is explicitly designed for this purpose.
- Never plug or unplug connectors during thunderstorms. There is a risk of electric shock.
- Ensure that the device has a protective and functional earth connection.

Damage to property, loss of data and impairment of functions

- If you change the hardware and software configurations, you must keep within the specified limits of power consumption and power loss (please refer to the respective data sheet).
- Ensure that only trained specialists with a control and automation engineering background, operate the device. Use by unauthorized persons can lead to damage to property and loss of data.
- In the case of a 24 V DC power supply unit, fuse the power supply line according to its cross-section to protect the supply line in the event of a short circuit.
- In case of fire, extinguish the device with powder or nitrogen.

2.4 Operator's obligation to exercise diligence

The operator must ensure that

- the products are used only for their intended purpose (see Chapter 2.2 [Intended use](#) [▶ 6]).
- the products are only operated in sound condition and in working order.
- the products are operated only by suitably qualified and authorized personnel.
- the personnel is instructed regularly about relevant occupational safety and environmental protection aspects, and is familiar with the operating instructions and in particular the safety instructions contained herein.
- the operating instructions are in good condition and complete, and always available for reference at the location where the products are used.

2.5 Notes on information security

The products of Beckhoff Automation GmbH & Co. KG (Beckhoff), insofar as they can be accessed online, are equipped with security functions that support the secure operation of plants, systems, machines and networks. Despite the security functions, the creation, implementation and constant updating of a holistic security concept for the operation are necessary to protect the respective plant, system, machine and networks against cyber threats. The products sold by Beckhoff are only part of the overall security concept. The customer is responsible for preventing unauthorized access by third parties to its equipment, systems, machines and networks. The latter should be connected to the corporate network or the Internet only if appropriate protective measures have been set up.

In addition, the recommendations from Beckhoff regarding appropriate protective measures should be observed. Further information regarding information security and industrial security can be found in our <https://www.beckhoff.com/secguide>.

Beckhoff products and solutions undergo continuous further development. This also applies to security functions. In light of this continuous further development, Beckhoff expressly recommends that the products are kept up to date at all times and that updates are installed for the products once they have been made available. Using outdated or unsupported product versions can increase the risk of cyber threats.

To stay informed about information security for Beckhoff products, subscribe to the RSS feed at <https://www.beckhoff.com/secinfo>.

3 Product overview

The industrial PC belongs to the series of powerful industrial PCs for control cabinet installation with ATX motherboard. The device is suitable for various applications and requirements.

Thanks to the available processors, the industrial PC can be used for the following applications, among others:

- diverse automation and visualization tasks
- wide range of IoT tasks with data preprocessing
- complicated HMI applications
- extensive axis controllers
- short cycle times
- high-volume data handling

The basic configuration of the CP6500-2000-0100 includes the following aspects:

- ATX motherboard
- Intel® processor
- 2 x DRAM SODIMM
- 2½-inch SSD
- 24 V DC power supply unit

3.1 Structure



Fig. 1: Structure

Table 1: Legend: CP6500-2000-0100 structure

No.	Component	Description
1	Mounting option	Holes for mounting the industrial PC in the control cabinet
2	Connection compartment	Access to interfaces of the industrial PC
3	Housing cover	Access to exchangeable device components
4	Status LEDs	Status display for hard disk, power
5	Name plate	Information on the equipment of the industrial PC

3.2 Interface description

In the basic configuration, the industrial PC includes the following interfaces:

- Power supply (X101)
- PS/2 mouse and keyboard (X103, X104)
- USB (X108-X111)
- Ethernet RJ45 (X112, X113)
- DVI (X114, X115)
- RS232 (X116)
- DisplayPort (X117)
- Audio connections (X120-X122)

3.2.1 Power supply

The industrial PC is equipped with a 24 V_{DC} power supply unit. It is supplied with a nominal voltage of 24 V. The power supply (X101) is connected via a 5-pin socket. The external wiring (X102) of the industrial PC is done via a 3-pin socket.

The main supply voltage is applied between PIN 1 (24 V) and PIN 2 (0 V) of the voltage socket (X101). If the industrial PC is equipped with an integrated uninterruptible power supply (UPS), you can also connect an external battery pack to PIN 4 and 5.

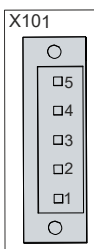

Fig. 2: Voltage socket pin numbering

Table 2: Voltage socket (X101) pin assignment

Pin	Signal	Description
1	+24 V	24 V supply voltage, positive pole
2	-	24 V supply voltage, negative pole
3	⊕	Protective earth
4	+BAT	Positive pole of the battery pack
5	-BAT	Negative pole of the battery pack

The positive pole of the supply voltage at PIN 1 of the voltage socket (X101) is looped through to PIN 3 of the socket (X102). PIN 3 thus serves as the positive pole for PC-ON.

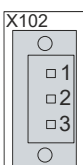

Fig. 3: Socket external wiring pin numbering

Table 3: Socket external wiring (X102) pin assignment

Pin	Signal	Description
1	P-S	Output power status, minus is the negative pole of the power supply (X101)
2	PC-ON	Input PC-ON
3	+24 V	Supply voltage and positive pole for PC-ON

3.2.2 PS/2

The industrial PC has two PS/2 interfaces (X103, X104). The upper interface (X104) allows the connection of a PS/2 mouse, the lower interface (X103) allows the connection of a PC keyboard. The connection is made via standard MiniDIN connectors.

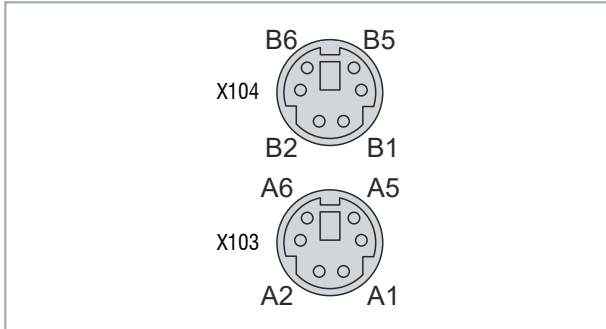

Fig. 4: PS/2 mouse and keyboard

Table 4: PS/2 interface mouse pin assignment

Pin	Name	Description
B1	MDAT	Mouse Data
B2	N/C	Reserved
B3	GND	Ground
B4	(S)VCC	5 V supply voltage
B5	MCLK	Mouse Clock
B6	N/C	Reserved

Table 5: PS/2 interface keyboard pin assignment

Pin	Name	Description
A1	KDAT	Keyboard data
A2	MDAT	Mouse Data
A3	GND	Ground
A4	(S)VCC	5 V supply voltage
A5	KCLK	Keyboard Clock
A6	MCLK	Mouse Clock

3.2.3 USB

The industrial PC has four USB interfaces (X108-X111). They are used to connect peripheral devices with USB interfaces.

Table 6: USB interface pin assignment

Pin	Connection
1	Vbus
2	D -
3	D +
4	GND
5	StdA_SSRX -
6	StdA_SSRX +
7	GND_DRAIN
8	StdA_SSTX -
9	StdA_SSTX +

3.2.4 Ethernet RJ45

The industrial PC has two Gigabit LAN ports (X112, X113). The 100Base-T and 1000Base-T Ethernet standards enable the connection of corresponding network components and data rates of 100/1000 Mbit/s. The required speed is selected automatically.

The RJ45 connection technology with twisted-pair cables is used. The maximum length of the cable connection is 100 m.

The industrial PC may only be connected to internal Ethernet networks without leaving the facility. The PC must not be connected to external telecommunication networks.

Intel® i219 for LAN1 and i210 for LAN2 are used as controllers.

If you use the Ethernet ports with EtherCAT or for Real-Time Ethernet applications, you have to regard the following distinction:

The Ethernet port (X113, LAN2) connected via PCIe with the i210 controller is generally suitable for cycle times ≤ 1 ms and for distributed clock applications with EtherCAT.

The Ethernet port (X112, LAN1) integrated in the chipset with the i219 controller is generally suitable for EtherCAT and real-time Ethernet applications with cycle times > 1 ms (without distributed clocks).

Table 7: Ethernet interface pin assignment

Pin	Signal	Description
1	T2 +	Pair 2
2	T2 -	
3	T3 +	Pair 3
4	T1 +	Pair 1
5	T1 -	
6	T3 -	Pair 3
7	T4 +	Pair 4
8	T4 -	

The LEDs of the LAN interfaces indicate the activity and the velocity of the data transmission (Mbit/s). The LED on the left in the figure indicates whether the interface is connected to a network. If this is the case, the LED lights up green. The LED flashes when data transmission is in progress on the interface.

The LED on the right in the figure indicates the speed of the data transmission. If the speed is 100 Mbit/s the LED is orange, at 1000 Mbit/s it is green.

3.2.5 DVI

The industrial PC has two DVI connections (X114, X115), to which a DVI-capable monitor can be connected. Only digital signals are transmitted.

Table 8: DVI interface pin assignment

Pin	Connection	Pin	Connection	Pin	Connection
1	TMDS Data 2 +	9	TMDS Data 1 -	17	TMDS Data 0 -
2	TMDS Data 2 +	10	TMDS Data 1 +	18	TMDS Data 0 +
3	TMDS Data 2/4 Shield	11	TMDS Data 1/3 Shield	19	TMDS Data 0/5 Shield
4	not connected	12	not connected	20	not connected
5	not connected	13	not connected	21	not connected
6	DDC Clock	14	+ 5 V Power	22	TMDS Clock Shield
7	DDC Data	15	Ground (+ 5 V, Analog H/V Sync)	23	TMDS Clock +
8	Analog Vertical Sync	16	Hot Plug Detect	24	TMDS Clock -

3.2.6 RS232

The serial interface COM1 (X116) is fed out via a 9-pin standard DSUB connector. The signals comply with the RS232 standard. The port address and the used interrupt are configured automatically, but can also be set manually with the help of the BIOS setup if required.

Table 9: RS232 pin assignment

Pin	Signal	Description
1	DCD	Data Carrier Detect
2	RxD	Receive Data
3	TxD	Transmit Data
4	DTR	Data Terminal Ready
5	GND	Ground
6	DSR	Data Set Ready
7	RTS	Request to Send
8	CTS	Clear to Send
9	RI	Ring Indicator

3.2.7 DisplayPort

The industrial PC has a DisplayPort (X117) that enables connection of devices with DisplayPort. Additionally, DVI signals can be transmitted via an adapter cable. The following ordering option is available to you for this purpose:

- C9900-Z468: adapter cable DisplayPort to DVI, 40 cm

Table 10: Pin assignment of DisplayPort

Pin	Connection	Pin	Connection
1	LVDS lane 0 +	2	Ground
3	LVDS lane 0 -	4	LVDS lane 1 +
5	Ground	6	LVDS lane 1 -
7	LVDS lane 2 +	8	Ground
9	LVDS lane 2 -	10	LVDS lane 3 +
11	Ground	12	LVDS lane 3 -
13	Config 1	14	Config 2
15	AUX channel +	16	Ground
17	AUX channel -	18	Hot-plug detection
19	Power supply: ground	20	Power supply: 3.3 V / 500 mA

3.2.8 Audio connections

The industrial PC has three audio connections with the Line In (X122), Line Out (X121) and microphone input (X120) sockets.

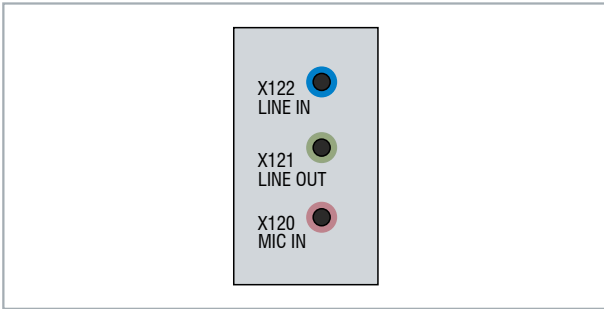

Fig. 5: Audio connections

The three sockets are brought out for 3.5 mm jack plugs. The pins of the jack plugs are assigned as follows:

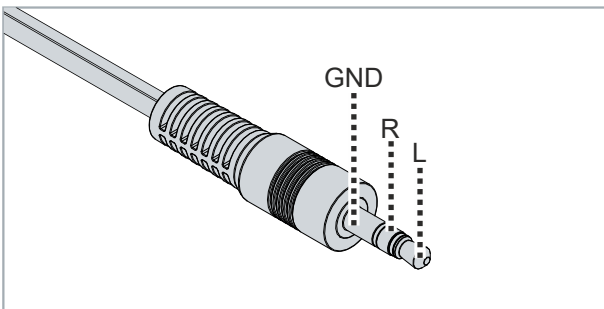

Fig. 6: Jack plug pin assignment

Table 11: Jack plug pin assignment

Pin	Connection
L	Left sound signal
R	Right sound signal
GND	Common ground (return)

3.3 Status LEDs

The industrial PC has two status LEDs: HDD, Power. They provide information on the following aspects:

- the hard disk activity
- the status of the power controller

Table 12: Meaning LEDs

LED	Color	Meaning
HDD	red	Access to storage medium
Power	green	Operation

3.4 Name plate

The name plate provides information on the equipment fitted to your industrial PC. The name plate shown here serves only as an example.

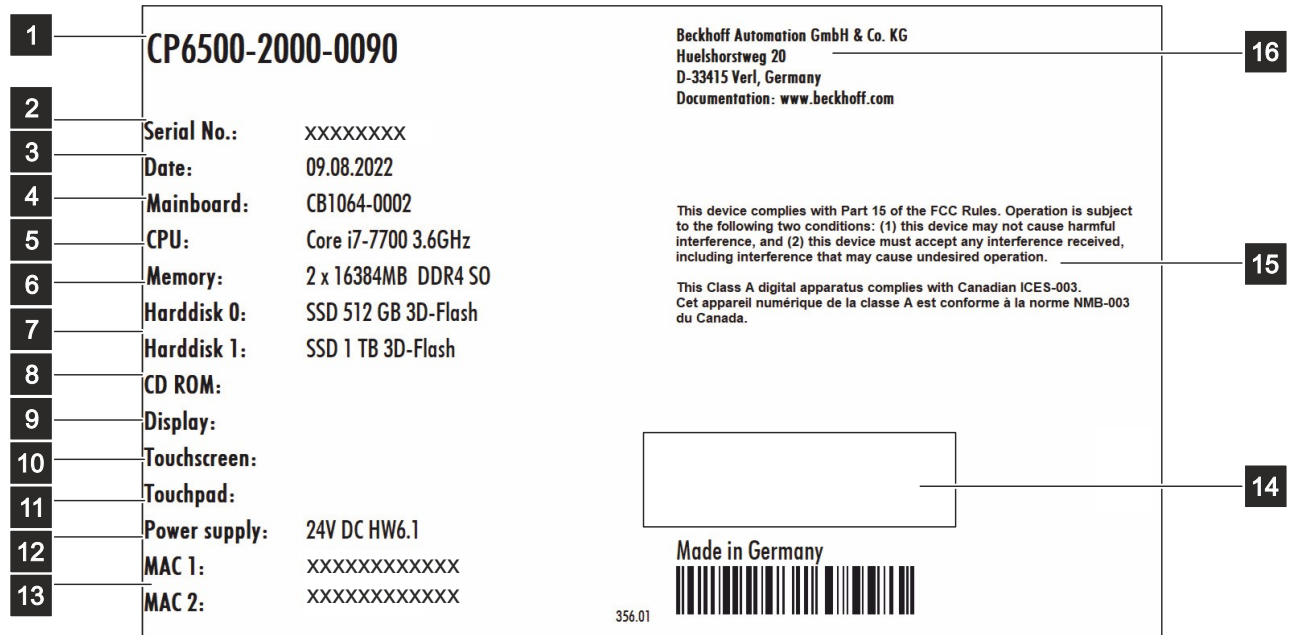



Fig. 7: Name plate

Table 13: Legend: name plate CP6500-2000-0100

No.	Description
1	Model: The last four digits indicate the device generation
2	Serial number (BTN)
3	Date of manufacture
4	Mainboard
5	CPU
6	Main memory
7	Storage media
8	DVD drive
9	Display
10	Touch screen
11	Touch pad
12	Power supply
13	MAC addresses of the Ethernet interfaces (X112, X113)
14	Symbols <div style="text-align: right;">  </div> Note: Here are the symbols applicable to the device such as CE, EAC, UKCA,  . The approvals of your device can be found on the name plate and in chapter 10.2 Approvals 45].
15	FCC approval
16	Address of the vendor

4 Commissioning

To be able to use the industrial PC, you must first commission it. The first step is to transport the device to its operating location and unpack it. This is followed by installing the device in the control cabinet, connecting the cables and the power supply and finally switching on the industrial PC.

4.1 Transport and unpacking

Note the specified transport and storage conditions (see Chapter 9 [Technical data](#) [▶ 43]).

Despite the robust design of the unit, the components are sensitive to strong vibrations and impacts. Transporting a control cabinet with a built-in PC can result in excessive impact on the industrial PC. During transport the device must therefore be protected from excessive mechanical stress. Appropriate packaging of the industrial PC, in particular the original packaging, can improve the vibration resistance during transport.

NOTICE

Hardware damage due to condensation

Unfavorable weather conditions during transport can cause damage to the device.

- Protect the device against moisture (condensation) during transport in cold weather or in case of extreme temperature fluctuations.
- Do not put the device into operation until it has slowly adjusted to the room temperature.
- Should condensation occur, wait for about 12 hours before switching the device on.

Unpacking

Proceed as follows to unpack the unit:

1. Remove packaging.
2. Keep the packaging for possible future transport.
3. Check your delivery for completeness by comparing it with your order.
4. Check the contents for visible shipping damage.
5. In case of discrepancies between the package contents and the order, or in case of transport damage, please inform Beckhoff Service (see Chapter 10.1 [Service and Support](#) [▶ 44]).

4.2 Control cabinet installation

NOTICE

Extreme environmental conditions

Extreme environmental conditions can cause damage to the device.

- Avoid extreme environmental conditions.
- Protect the device against dust, moisture and heat.

NOTICE

Incorrect installation

Incorrect installation in a control cabinet prevents air circulation in the device and causes impaired functioning.

- Only install the device in the orientation specified below.

The device is designed for installation in the front of a control cabinet in machine and system engineering. The environmental conditions specified for operation must be observed.

Only install the device in the control cabinet with the interfaces facing upwards.

You can use the mounting concept (see Fig. 13) to mount the industrial PC in the control cabinet.

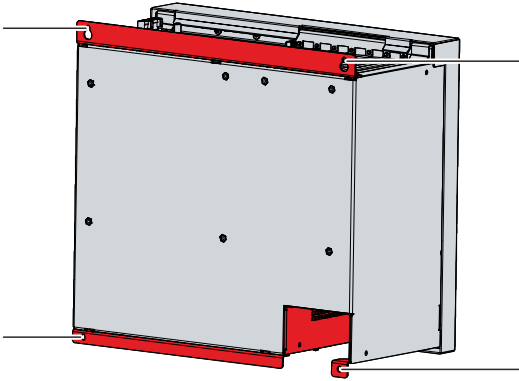

Fig. 8: Mounting concept

Dimensions

The dimensions of the industrial PC are used to prepare the control cabinet and to mount the device correctly in the control cabinet.

All dimensions are in mm.

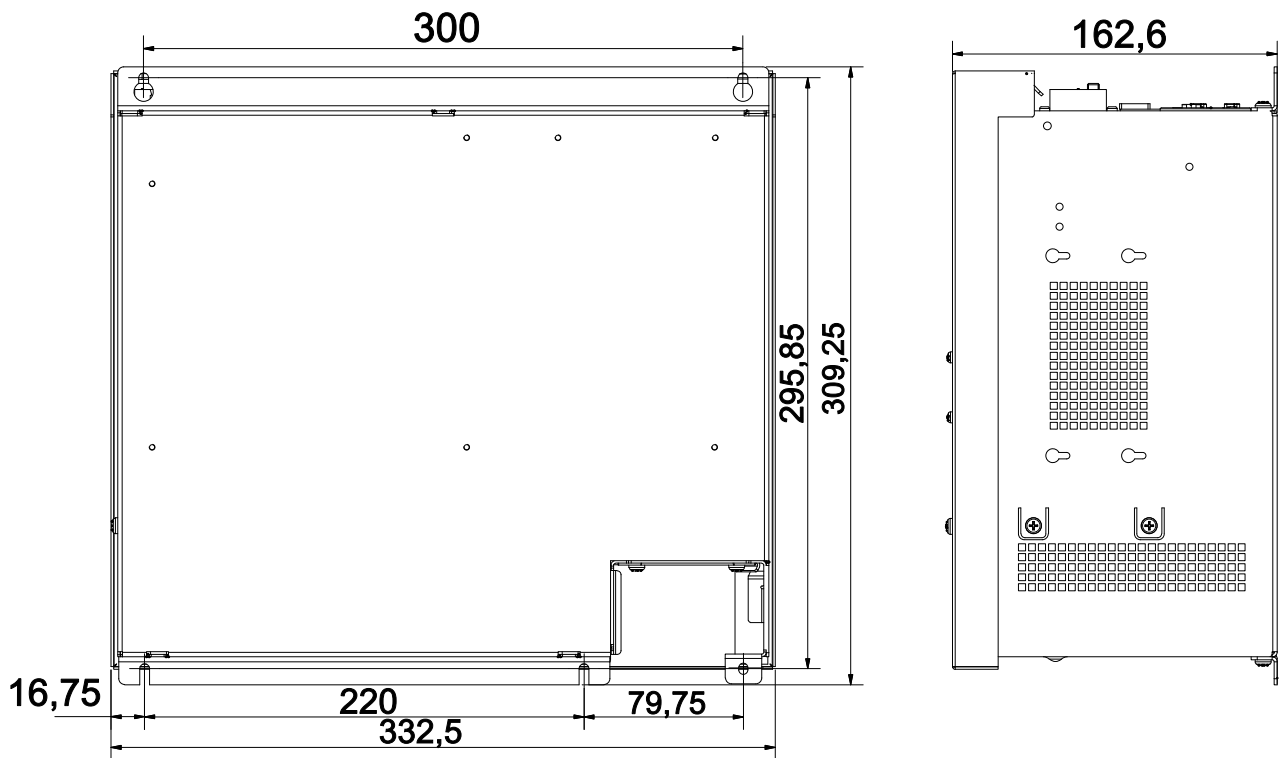

Fig. 9: Dimensions

Installation in the control cabinet

When installing in the control cabinet, note that there must be 5 cm of free space above and below the device for ventilation.

To mount the industrial PC in the control cabinet, you must provide it with the holes for the fastening screws according to the device dimensions of the PC (see above). You need M4 screws for mounting.

After you have drilled the holes for the fastening screws in the control cabinet, you can mount the industrial PC in the control cabinet.

To mount the industrial PC in the control cabinet, follow the steps below, which are shown in Figure 15:

1. Insert the upper fastening screws into the drill holes in the control cabinet.
 2. Place the PC on the screws with the keyholes at the top of the mounting concept (section A).
 3. Move the PC down so that it hangs on the screws (section B).
 4. Insert the lower fastening screws in the drill holes in the control cabinet (section C).
 5. Tighten all fastening screws.
- ⇒ You have successfully installed the industrial PC in the control cabinet.

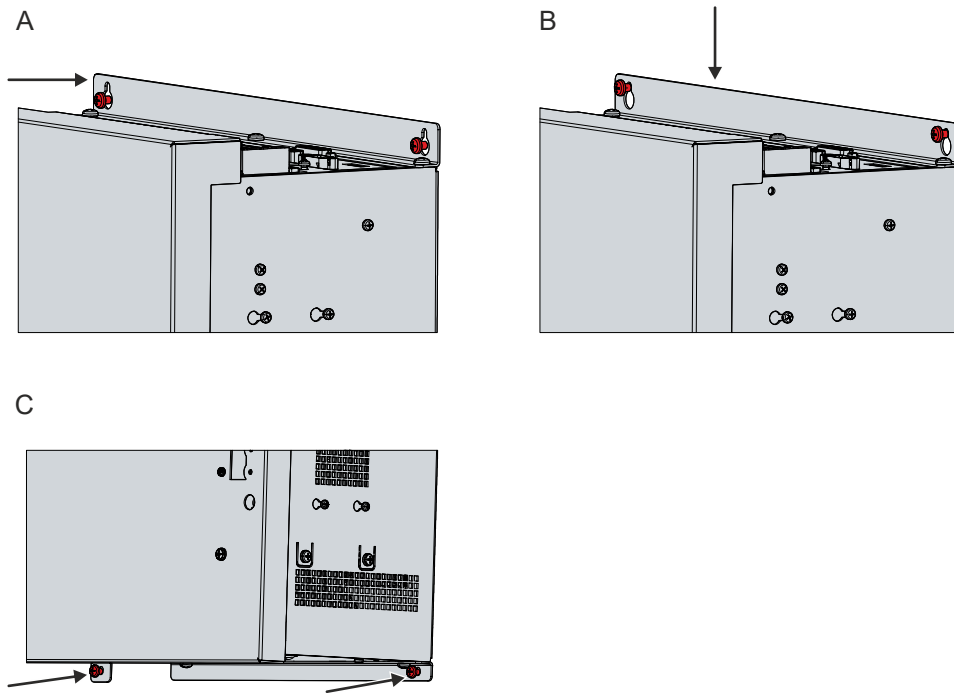

Fig. 10: Control cabinet installation

Also see about this

📄 [Technical data](#) [▶ 43]

4.3 Connecting the industrial PC

⚠ CAUTION

Risk of electric shock

Dangerous touch voltages can lead to electric shock. To avoid electric shock, observe the following:

- Never connect or disconnect the device cables during a thunderstorm.
- Provide protective earthing for handling the device.

To prepare the industrial PC for operation, it must be connected. The first step is to ground the device. Then you can connect the cables and the power supply.

The cabling of the industrial PC in the control cabinet must be done in accordance with the standard EN 60204-1:2006 PELV = Protective Extra Low Voltage:

- The PE conductor (protective earth) and the "0 V" conductor of the voltage source must be on the same potential (connected in the control cabinet).
- Standard EN 60204-1:2006, section 6.4.1:b stipulates that one side of the circuit, or a point of the energy source for this circuit must be connected to the protective conductor system.

Devices connected to the industrial PC with their own power supply must have the same potential for the PE and "0 V" conductors as the industrial PC (no potential difference).

4.3.1 Mounting power supply cable

Install the cable for the power supply of the industrial PC using the material supplied for connector assembly. This consists of the 5-pin connector and the strain relief housing with cable clamp and fixing screws.

If you need a replacement for the power supply connector and strain relief housing, you can order this from Beckhoff Sales by specifying the following ordering option:

- C9900-P917: Power supply connector for industrial PC, connector with strain relief for the external supply cable with 24 V label

Mounting power supply cable

The minimum temperature of the power supply cable must be 70 °C.

First mount the plug on the cable as follows:

1. Remove 28 mm of the cable sheath.
2. Remove the insulation from the wire ends (8-9 mm).
3. Crimp the ferrules onto the stripped wire ends.
4. Plug the wire ends with the ferrules into the 5-pin connector strip according to the pin assignment sticker and the wiring diagram (p.27).

⇒ You have mounted the plug on the cable.

Assembly of strain relief housing

Now mount the strain relief housing on the previously connected plug and power supply cable as shown in Fig. 16:

1. Insert the connection strip into the lower part of the strain relief housing (section A).
2. Place the strain relief clamp on the sheath of the power supply cable and screw the strain relief clamp tight (section B).
3. Attach the upper part of the strain relief housing by snapping it onto the lower part (section C).

⇒ You have mounted the strain relief housing (section D).

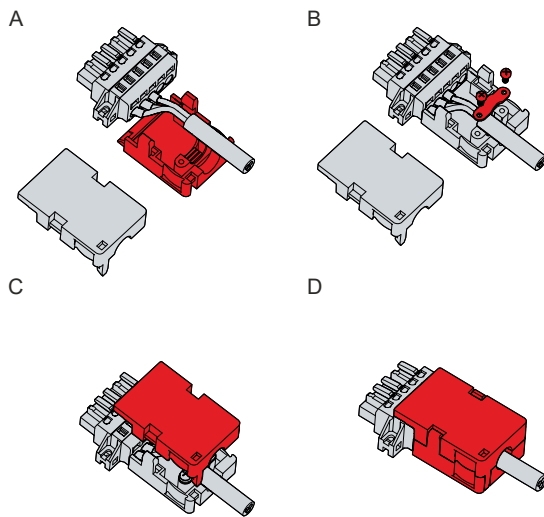

Fig. 11: Assembly of the strain relief housing

To remove the strain relief housing, proceed as follows:

1. Use your fingers to bend the latching lugs on the lower part slightly outwards (see Fig. 17).
 2. Lever the upper part off the lower part.
 3. Loosen the screws of the strain relief clamp.
 4. Remove the strain relief clamp.
- ⇒ You have removed the strain relief housing.

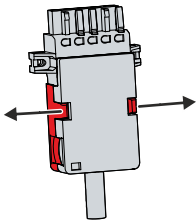

Fig. 12: Disassembly of the strain relief housing

4.3.2 Grounding of the industrial PC

Potential differences are minimized and electrical currents are diverted to the ground through grounding or potential equalization of electronic devices. This is to prevent dangerous touch voltages and electromagnetic interference.

The protection provided by the devices may be impaired by non-intended use.

All connected devices must be in SELV (Safety Extra Low Voltage)/PELV (Protective Extra Low Voltage) circuits.

Protective earth

The protective grounding of a device serves to avoid dangerous touch voltages. According to the EN 60204-1 standard (Chapter 8 Potential equalization), protective grounding is required if:

- the device exceeds dimensions of 50 mm x 50 mm,
- the device can be touched or encompassed over a large area,
- contact between the device and active parts is possible,
- an insulation fault may occur.

There is a pin in the voltage socket for the protective earth (PE) of the device. Establish the low-resistance protective earth of the industrial PC via the voltage connection, thus avoiding dangerous touch voltages.

EMC

NOTICE

Hardware damage due to electromagnetic interference

Using the industrial PC without functional earthing can lead to hardware damage due to electromagnetic interference.

- Only use the device with functional earth.

Electromagnetic compatibility (EMC) refers to the industrial PC's ability not to interfere with other devices and equipment through electromagnetic interference, and not to be disturbed by electrical or electromagnetic effects.

For this purpose, the industrial PC must comply with certain protection requirements. The industrial PC has EMC interference immunity according to EN 61000-6-2. The EMC interference emission of the device meets the requirements of EN 61000-6-4.

The functional earth is necessary for the EMC of the device. You establish functional earthing via the grounding connection between the grounding bolt in the connection section on the top of the industrial PC and the central grounding point of the control cabinet in which the PC is installed. Use either a wide, flat ground strap or a round conductor with a minimum cross-section of 10 mm² for the ground connection. In the case of a round conductor, also use a cable lug with a ring and place the ring over the grounding bolt.

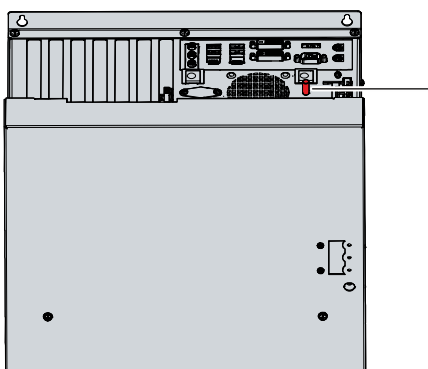

Fig. 13: Grounding bolt for functional earthing

4.3.3 Connecting cables and power supply

NOTICE

Incorrect connection procedure

Incorrect procedure when connecting the cables and the power supply can cause hardware damage.

- Follow the documented procedure for connecting the cables and the power supply.
- Always connect the cables first and only then switch on the power supply.
- Please read the documentation for the external devices prior to connecting them.

NOTICE

Connection of incorrect battery packs

The connection of incorrect battery packs can lead to damage to the industrial PC and to the battery packs.

- Only connect the C9900-U330 Beckhoff battery pack to your industrial PC.

Connecting cables

The connections are located on the top side of the industrial PC. They are documented in chapter 3.1 Structure.

Make sure that you first connect the functional earth to the grounding bolt of the PC (see chapter 4.3.1 [Grounding the industrial PC](#) [► 25]) and then plug in all data transmission lines.

Connecting the power supply

Cables with a maximum cable cross-section of 1.5 mm² can be used for connecting the power supply. For long supply lines, use 1.5 mm² cables to achieve a low voltage drop on the supply line. There should be at least 22 V at the power supply connector of the industrial PC, so that the PC remains switched on during voltage fluctuations.

Proceed as follows to connect the 24 V_{DC} power supply unit:

1. Mount the power supply cable (see p. 23).
 2. Plug the power supply cable into the power supply socket of the industrial PC.
 3. Connect the industrial PC to your external 24 V power supply.
 4. Switch on the 24 V power supply.
- ⇒ You have connected the power supply.

External battery pack at C9900-P209

If you ordered your device with an integrated UPS, then you can connect an external battery pack and install it on a DIN rail near to the PC. Use only Beckhoff battery packs for this:

Table 14: Order identifier battery pack

Order identifier	Version
C9900-U330	Battery pack for PCs with 24 V power supply unit and integrated UPS C9900-P209 or C9900-U209, external for DIN rail mounting, 3.4 Ah, operating temperature 0...50 °C, contains two closed lead-acid batteries VRLA-AGM

PIN 4 and 5 of the battery pack are available for looping through a 24 V power supply. Accordingly, you can connect a three-core sheathed cable with plus and minus of the supply voltage as well as protective earth to the battery pack and then connect to the PC with a five-core sheathed cable. The method of connecting different components can be taken from the wiring diagram in fig. 19.

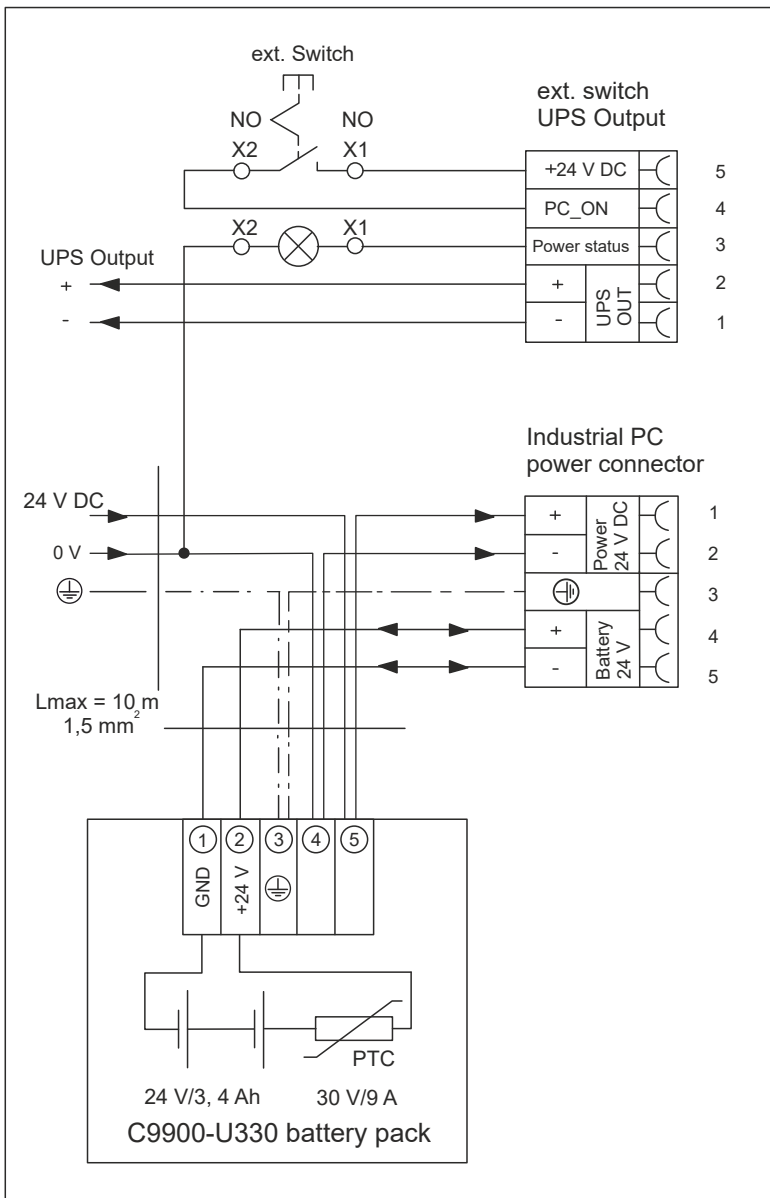

Fig. 14: Wiring diagram

For more information on the battery pack, please refer to the corresponding [manual](#).

4.4 Switching the industrial PC on and off

NOTICE

Public networks

Connecting the device to public networks without additional protective measures can compromise the safety of the device.

- Protect the device before connecting it to public networks.

NOTICE

Data loss due to switching off the device while the software is running

Switching off the device before the running software is terminated and the operating system is shut down can lead to data loss.

- Quit the running software and shut down the operating system before switching off the device.

NOTICE

Shortened battery life due to switching off the power supply

If the power supply is simply switched off, the operating system shuts down via the battery. With daily use, this significantly shortens the life of the battery.

- Avoid switching off the power supply before shutting down the operating system.
- Use the PC-ON input (see the following description) to shut down the operating system in a battery-friendly manner.

The industrial PC is started or switched off when the system is switched on or off or when the power supply to the PC is connected or disconnected.

You can use the PC-ON input of the PC to control the startup and shutdown of the operating system. The PC-ON signal is inverted, which is why the operating system boots up at 0 V at the input and shuts down at 24 V. During operation, 0 V must therefore be permanently applied to the input. If you want to shut down the operating system, you must apply 24 V to the PC-ON input. Once the operating system has shut down, the PC power supply unit sets the Power Status output from 24 V to 0 V. This indicates that the shutdown is complete. You can then switch off the power supply. If you remove the 24 V from the PC-ON input before you have switched off the power supply, the operating system restarts. Therefore, 24 V must be applied to the PC-ON input until you have switched off the power supply.

To shut down the operating system properly, you can install an additional ON/OFF switch next to the machine's main switch to turn the machine on and off. The main switch can thus remain switched on in principle and thus ensures that the PC is still supplied with power during the shutdown of the operating system. Via the Power Status output, you can switch, for example, a contactor that switches off the entire system. The load capacity of the Power Status output is limited to max. 0.5 A. No fuse protection is required.

If you switch off the power supply before you have shut down the operating system properly, it shuts down using the battery. With frequent use, this shortens the life of the battery.

Driver installation

When you switch on the device for the first time, the optionally pre-installed operating system will be started. For any additional hardware you have connected, you have to install the drivers yourself afterwards. In addition, the Beckhoff Device Manager starts automatically. The Device Manager is a software from Beckhoff that supports you in configuring the device.

If you have ordered the device without an operating system, you must install this and the driver software for the additional hardware you have connected and for the components inside the device. Please follow the instructions in the documentation for the operating system and the additional components.

UPS software components

The UPS software components with the corresponding drivers must be installed on the PC in order to operate the power supply unit as a UPS. The software components and drivers are already installed on delivery of the PC with operating system. If they are not, you have to install the installation package *Beckhoff UPS* yourself.

You can obtain the installation package from Beckhoff Service (service@beckhoff.com). You then use the installation package to install the UPS software components. The UPS software components come with a detailed help function. Call up the help files either directly from the configuration register by clicking the Help button or start the file under *Start > Programs > Beckhoff > UPS software components*.

5 Beckhoff Device Manager

The Beckhoff Device Manager enables detailed system diagnostics with uniform secure access to the existing hardware and software components. System data is recorded, analyzed and evaluated during operation. The data helps to detect deviations at an early stage and prevent device downtimes.

The user interface screenshots shown in this chapter are examples only and do not represent the actual state of your device.

The Beckhoff Device Manager always starts automatically after the device has been booted. In addition, you have the option of manually starting the previously closed Device Manager at any time.

The device is supplied with predetermined access data by default:

- User name: Administrator
- Password: 1

You also have the option of using the Beckhoff Device Manager to remotely configure the device via a web browser. More detailed information is available in the Beckhoff Device Manager [manual](#).

First start of Beckhoff Device Manager

When your device is booted for the first time, the Beckhoff Device Manager also starts automatically for the first time. The Security Wizard opens. It informs you that you should reset the default password set by Beckhoff. Proceed as follows:

1. Click **Next** on the Security Wizard start page.
 - ⇒ This will take you to the **Change Passwords** page:

BECKHOFF Device Manager

Change Passwords

Your Beckhoff IPC is delivered with default user accounts and related default passwords! It is strongly recommended to change the default passwords to prohibit unauthorized access to your Beckhoff IPC. Please note that these passwords are valid for the access to the Beckhoff Device Manager, too.

Change the default password of the user account(s) to prohibit unauthorized access to your Beckhoff IPC.

Local Users	Administrator
Password	<input type="text"/>
New Password	<input type="text"/>
New Password (confirm)	<input type="text"/>

Auto Logon Enabled

<< Back Next >>

Fig. 15: Beckhoff Device Manager – Change passwords

2. Enter the access data of the Device Manager on delivery.
3. Choose a secure new password. Instructions for choosing a secure password are given below.
4. Confirm the changes by clicking on the tick in the red box on the right.
5. Exit the Security Wizard.
 - ⇒ You have reached the Device Manager start page.

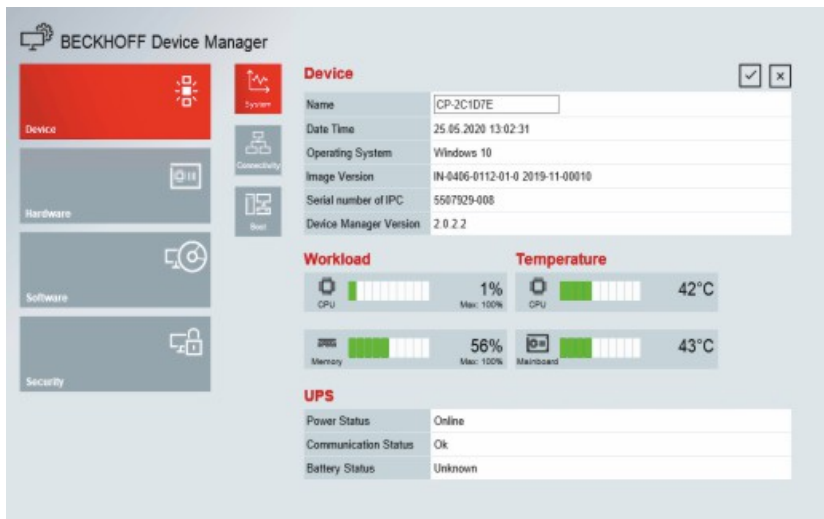

Fig. 16: Beckhoff Device Manager – Start page

Continue to navigate in the menu and to configure the device. Note that modifications only become active once they have been confirmed.

Manual start of Beckhoff Device Manager

To start the Beckhoff Device Manager manually, proceed as follows:

1. Open a web browser locally on the device.
 2. Enter *localhost/config* in the web browser to start the Beckhoff Device Manager.
- ⇒ The Beckhoff Device Manager starts. The Security Wizard appears.

Secure passwords

Strong passwords are an important prerequisite for a secure system.

Beckhoff supplies the device images with standard user names and standard passwords for the operating system. It is imperative that you change these.

Controllers are shipped without a password in the UEFI/BIOS setup. Beckhoff recommends assigning a password here as well.

Please note the following:

- Passwords should be unique for each user and service.
- Only change passwords after an incident in which passwords have become known without authorization.
- Train the device users in the use of passwords.

A secure password has the following characteristics:

- Password complexity: The password should contain capital and lower-case letters, numbers, punctuation marks and special characters.
- Password length: The password should be at least 10 characters long.

6 Decommissioning

NOTICE

Hardware damage due to power supply

A connected power supply can cause damage to the industrial PC during disassembly.

- Disconnect the power supply from the device before starting to disassemble it.

When taking the industrial PC out of operation, you must first disconnect the power supply and cables. You can then remove the device from the control cabinet.

If you do not wish to use the industrial PC any further, chapter 6.2 [Disassembly and disposal](#) [▶ 33] provides information on the correct disposal of the device.

6.1 Disconnecting the power supply and cables

⚠ CAUTION

Risk of electric shock

Disconnecting the industrial PC during a thunderstorm can lead to electric shock.

- Never disconnect the cables from the device during thunderstorms.

Before you remove the industrial PC from the control cabinet, you must disconnect the power supply and the cables. Follow the steps below:

1. Shut down the industrial PC.
2. Disconnect the industrial PC from the external power supply.
3. Pull the power supply plug out of the power supply socket.
4. Remove the power supply cable if the connector is to remain with the PC.
5. Make a note of the wiring of all data transmission cables if you want to restore the cabling with another device.
6. Disconnect the data transmission cables from the industrial PC.
7. Finally, disconnect the ground connection.

⇒ You have disconnected the power supply and the cables.

6.2 Disassembly and disposal

In order to be able to dismount the industrial PC from the control cabinet, you must first have disconnected the power supply and the cables (see Chapter 6.1 [Disconnecting the power supply and cables](#) [▶ 32]).

Removal from the control cabinet

To remove the industrial PC from the control cabinet, follow the steps below, which are shown in Figure 22:

1. Loosen and remove the two fastening screws at the bottom of the mounting concept of the industrial PC (section A). Make sure that the PC is secured against falling down.
2. Slide the industrial PC upwards until the fastening screws slip into the keyholes (section B).
3. Remove the industrial PC from the control cabinet (section C).

⇒ You have successfully removed the industrial PC from the control cabinet.

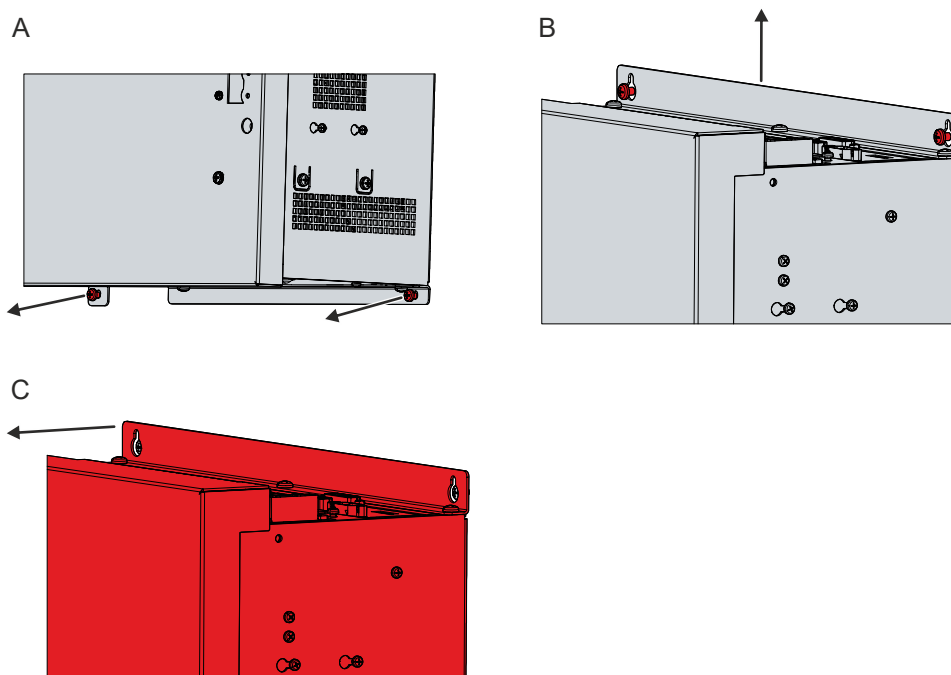

Fig. 17: Removal from the control cabinet

Disposal of the industrial PC

Be sure to observe the national electronic scrap regulations when disposing of the industrial PC.

In order to dispose of the device, it must be removed and fully dismantled. Dispose of the components in the following way:

- Send plastic parts (polycarbonate, polyamide (PA6.6)) for plastics recycling.
- Take metal parts to the metal recycling collection point.
- Electronic parts such as fans and circuit boards must be disposed of in accordance with national electronic scrap regulations.
- Stick insulating tape over the poles of the CR2032 battery on the motherboard and dispose of the battery via the local battery recycling.

7 Maintenance

⚠ CAUTION

Risk of electric shock

Working on the industrial PC while it is live can lead to electric shock.

- Turn off the supply voltage before cleaning the device or replacing device components. This does not apply to the replacement of hard disks and SSDs in a RAID configuration.

Maintenance measures increase the efficiency of the device by ensuring long-term functionality. Cleaning and maintenance of certain device components and the replacement of other device components contribute to this.

7.1 Cleaning

NOTICE

Unsuitable cleaning agents

The use of unsuitable cleaning agents can damage the device.

- Only clean the industrial PC as specified.

It is essential to observe the following aspects when cleaning the industrial PC:

- Keep to the boundary conditions of protection rating IP65/IP20.
- Only use a vacuum cleaner to clean the PC. The industrial PC does not have to be switched off for this.
- Never use compressed air to clean the PC.
- Maintain an ambient temperature range of 0 °C to 55 °C.

7.2 Maintenance

NOTICE

Use of incorrect spare parts

The use of spare parts not ordered from Beckhoff Service can lead to unsafe and faulty operation.

- Only use spare parts that you have ordered from Beckhoff Service.

Beckhoff devices are manufactured from components of the highest quality and robustness. They are selected and tested for best interoperability, long-term availability and reliable function under the specified environmental conditions.

Nevertheless, some components of the devices may be subject to a limited service life if they are operated under certain conditions, such as at increased ambient temperatures during operation or during storage or during long periods of storage out of operation.

Beckhoff therefore recommends replacing some of the components of the devices after the time after which predictions of the remaining service life of such components can no longer be reliably calculated.

The following table provides recommendations for the regular, precautionary replacement of the device components:

Table 15: Device component replacement recommendations

Component	Recommendation for replacement intervals (years)
UPS battery pack	5 years
2.5-inch hard disk	5 years or after 20,000 operating hours at more than 40 °C or after 30,000 operating hours at less than 40 °C
3.5-inch hard disk	5 years, irrespective of the operating hours
Fan	7 years
CFast, SSD, MicroSD, Compact Flash	10 years
Motherboard battery	5 years

Beckhoff is excluded from liability in the event of possible damage occurring during maintenance work. In order to avoid damage caused by electrostatic discharge when replacing device components, protective measures are recommended. Below are some suggestions.

ESD protection

NOTICE

Electrostatic discharge

The replacement of device components without ESD protection can lead to functional impairment and destruction of the device.

- If possible, apply ESD protection measures during maintenance work.

When working on electronic devices, there is a risk of damage due to ESD (electrostatic discharge), which can impair the function or destroy the device.

Protect the device and create an ESD-protected environment in which existing electrostatic charges are safely discharged to ground and charging is prevented.

An ESD-protected environment can best be created by setting up ESD protection zones. The following measures serve this purpose:

- ESD-compliant floors with sufficient conductivity to the reference potential PE;
- ESD-compatible work surfaces such as tables and shelves;
- Wrist grounding strap, especially for sedentary activities;
- grounded and electrostatically dissipating equipment and operating materials (e.g. tools) within the ESD protection zone.

If it is not possible to create an ESD protection zone, you can still protect the device against ESD damage. For example, the following measures can be used:

- Use conductive mats connected to the ground potential as underlays.
- Dissipate possible charges from your own body by touching grounded metal (e.g. control cabinet door).
- Wear a wrist grounding strap.
- Only remove new electronic components from the ESD packaging (tinted plastic bag) after putting on the wrist grounding strap.
- Do not walk around with electronic components in your hand if they are not in ESD packaging.

Access to device components

To be able to replace the battery, storage media or fans, you must first gain access to these device components. These are located behind the housing cover.

To open the housing cover, follow the steps below as shown in Figure 23:

1. Loosen and remove the two M4 screws (section A).
 2. Place the housing cover in an inclined position by lifting it from the housing at the bottom end (section B).
 3. Remove the housing cover upwards (section C).
 4. Move the two levers upwards (section D).
 5. Move the inner chassis down (section E).
- ⇒ You now have access to the battery (1), fans (2), CPU cooler (3) and storage medium (4) (section F).

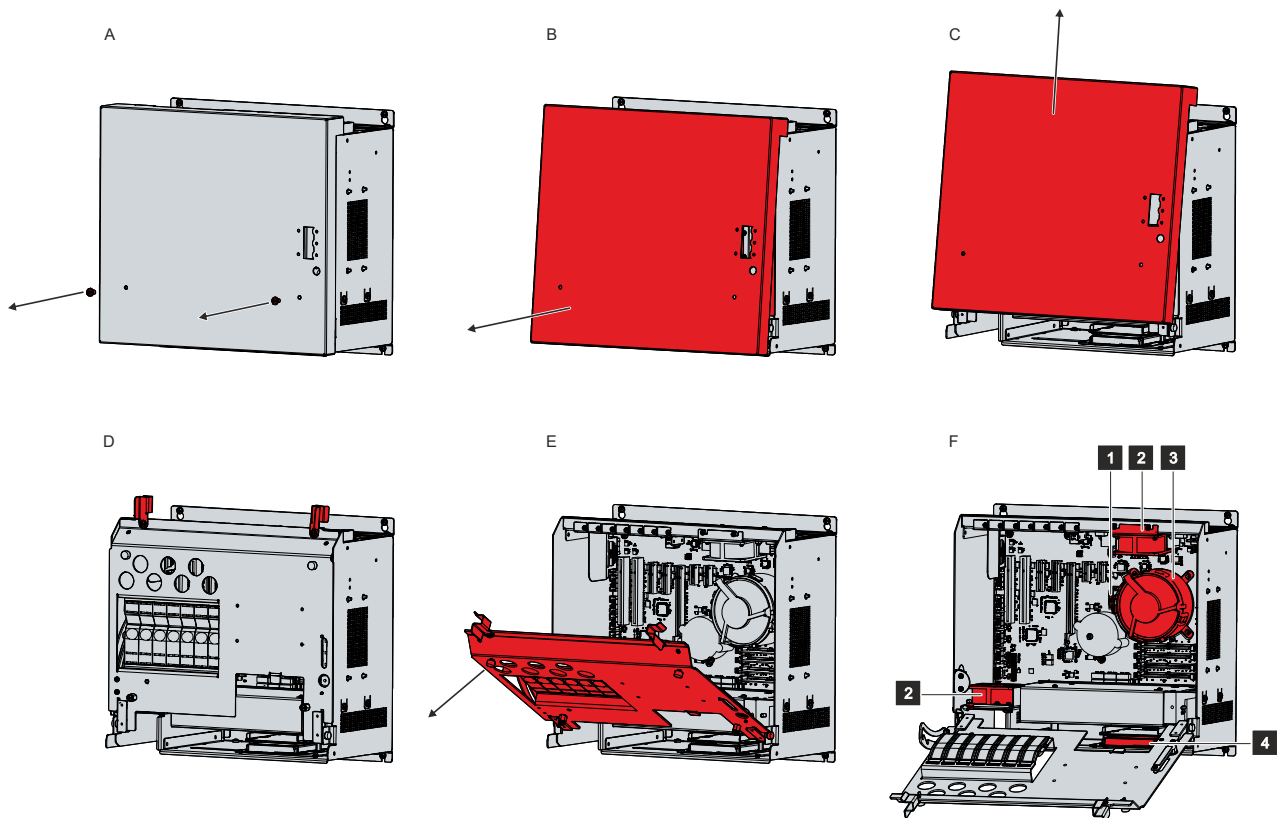

Fig. 18: Access to device components

7.2.1 Replacing the battery

NOTICE

Incorrect battery type

Using any other battery may cause fire or explosion.

- Only replace the battery with battery type R/C (BBCV2), order number RC2032, nominal voltage 3 V.
- When replacing the battery, make sure that the polarity is correct.

NOTICE

Battery damage

Incorrect handling of the motherboard battery can damage it.

- Do not recharge the battery.
- Do not throw the battery on the fire.
- Do not open the battery.
- Protect the battery against direct sunlight and moisture.

NOTICE

Failure of the electronics due to mechanical damage

Scratches or damaged components on PCBs can cause the electronics to fail.

- Be very careful when replacing the battery and avoid mechanical damage to the electronics.

The device does not contain a lithium-ion battery. The motherboard battery is a CR2032 lithium-metal cell. It is used to supply power to the clock integrated on the motherboard. If the battery is depleted or missing, the date and time are displayed incorrectly.

Table 16: Technical data of the battery

Battery type	Electrical properties (at 20 °C)		Dimensions		
	Nominal voltage	Nominal capacity	Diameter	Height	Weight
CR2032	3.0 V	225 mAh	20.0 mm	3.20 mm	3.1 g

Chapter 7.2 Maintenance [▶ 35] shows how to access the battery.

You may only replace the battery when the industrial PC is switched off.

To change the battery, proceed as follows:

1. Bend the hook on the battery holder slightly outward (section A).
2. Pull the battery out of the holder (section B).

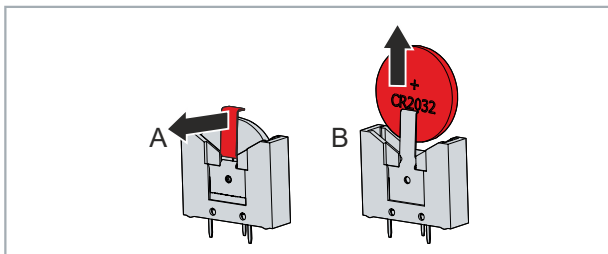

Fig. 19: Replacing the battery

3. Insert the new battery into the holder. Make sure that the polarity is correct, as shown.

⇒ You have successfully replaced the battery.

Battery disposal

To dispose of the battery, remove it, tape off the poles and put it in the battery disposal.

7.2.2 Replacing the storage media

For new storage media, please contact your Beckhoff Sales only. Hard disks from Beckhoff are optimized for industrial applications. SSDs have a considerably higher lifetime expectancy than commercially available SSDs.

Chapter 7.2 [Maintenance](#) [▶ 35] shows how to access the storage media.

Data transmission before replacement

If you want to exchange a storage medium according to Beckhoff's recommendation, you must copy the data from the old to the new storage medium. You can use the Beckhoff Service Tool (BST) for this purpose. BST is a graphical backup and restore program for devices with a Windows operating system. You can create an image of your operating system and use it to back up the operating system. Then you can restore the created image to a new data carrier. The BST is available on a bootable BST USB flash drive. This includes Windows and a backup tool. Select the size of the BST USB flash drive according to the size of the backup copy of your operating system. You can then keep the flash drive as a backup copy. For this purpose, the BST USB flash drives are designed for particularly long data preservation by means of special flash. For more information on the function of the BST, please refer to the corresponding [manual](#).

If your storage medium is defective and there is no backup, Beckhoff Service can provide you with a fresh Windows image. For this to be possible, your Beckhoff device must already have been delivered with a valid operating system license. After installing the fresh image, the applications must be reinstalled.

You can install up to two 2.5-inch hard disks in the industrial PC. Use SATA ports 0 and 1 for this purpose (see Fig. 25). You can alternatively install a 2.5-inch SSD in the SATA port 0.

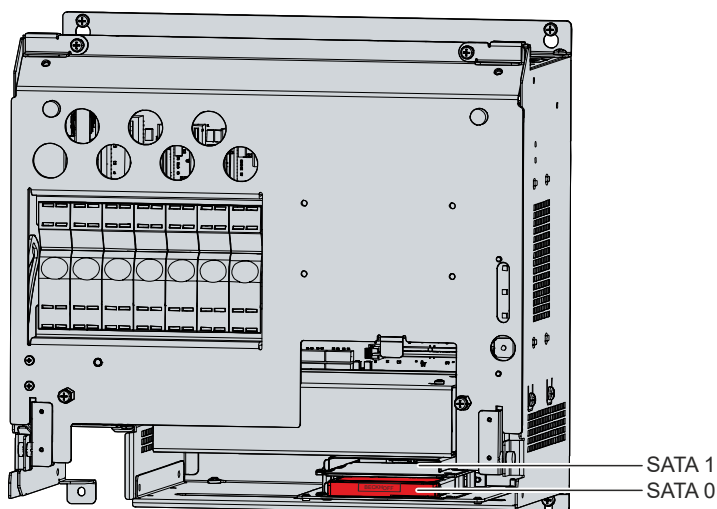

Fig. 20: Replacing the storage media

To replace hard disks or SSDs, follow the steps below:

1. Remove the storage medium from the PC by pulling forcefully on the protruding Beckhoff sticker.
 2. Insert the new storage medium into the PC in the same orientation up to the stop.
- ⇒ You have successfully replaced the storage medium.

7.2.3 Replacing the fan

NOTICE

Incorrect fan type

The industrial PC may be damaged if the wrong type of fan is installed.

- Only replace the fans with a fan from Beckhoff Service.

Before you can replace the fan and CPU cooler, you must gain access to the interior of the industrial PC (see chapter 7.2 Maintenance [▶ 35]). You must switch off the industrial PC before you can replace the fan or CPU cooler. Only order a new fan from your Beckhoff Sales.

To replace the fan on the top of the PC, follow the steps below shown in figure 26:

1. Secure the fan holder against falling down and remove the two M3 screws of the fan holder (section A).
 2. Disconnect the supply cable of the fan from the motherboard.
 3. Remove the fan holder with the fan (section B).
 4. Insert the new fan holder with fan again.
 5. Connect the supply cable to the motherboard.
 6. Retighten the two M3 screws.
- ⇒ You have successfully replaced the fan.

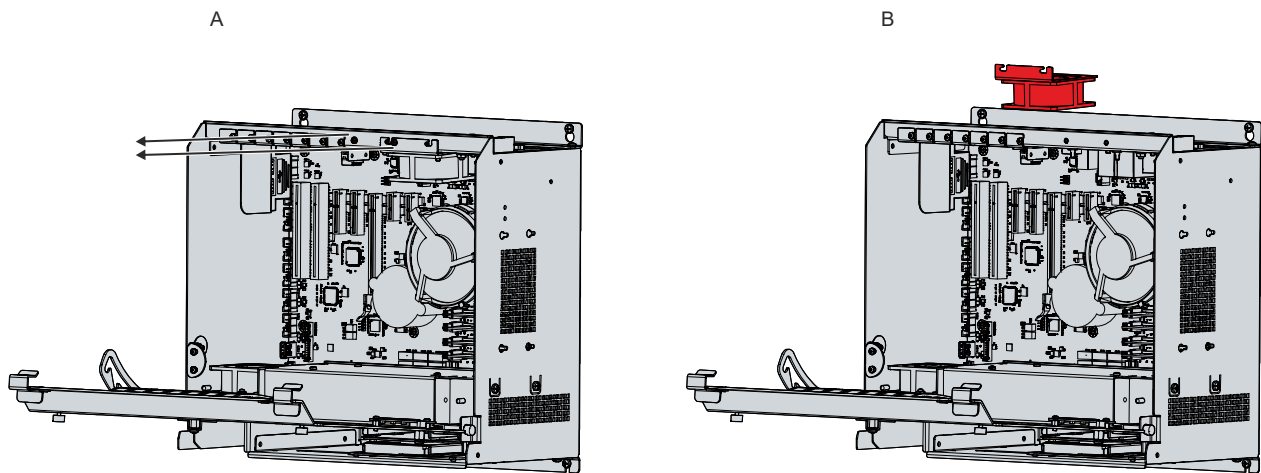

Fig. 21: Exchange fan top

To replace the fan on the bottom of the PC, follow the steps below, shown in Figure 27:

1. Secure the fan holder against falling down and remove the two M4 screws (section).
 2. Disconnect the supply cable of the fan from the motherboard.
 3. Remove the fan upwards out of the PC (section B).
 4. Insert the new fan.
 5. Connect the supply cable to the motherboard.
 6. Retighten the two M4 screws.
- ⇒ You have successfully replaced the fan.

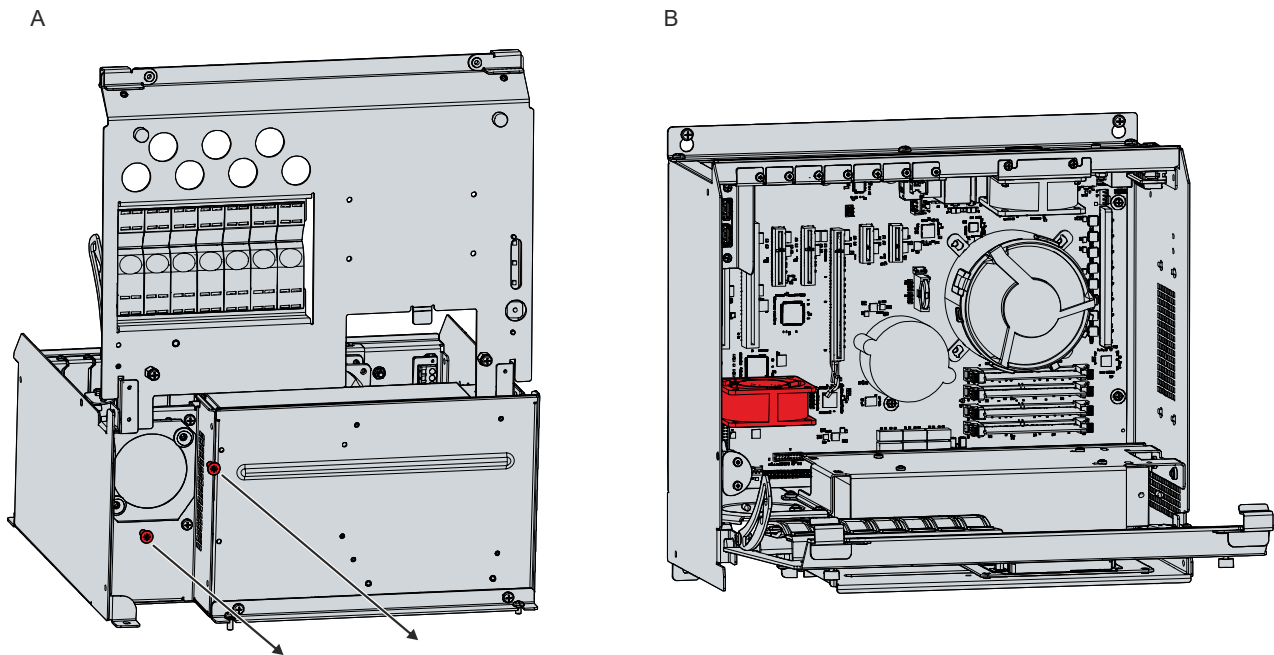

Fig. 22: Exchange fan bottom

Exchange CPU cooler

You can also replace the CPU cooler on the motherboard. Contact Beckhoff Service for a new cooler.

To replace the CPU cooler, follow the steps below as shown in Figure 28:

1. Turn the four locking elements in the direction of the arrow shown on them to unlock the cooler from the motherboard. (section A).
 2. Disconnect the supply cable of the cooler from the motherboard.
 3. Pull the cooler off the motherboard while pulling the locking elements out of the holes in the motherboard (section B).
 4. Remove the residues of the old thermal compound from the surface of the CPU. Use a paper towel moistened with alcohol for this purpose. Avoid ESD damage by never using a textile cloth.
 5. Place the new cooler with the locking elements into the holes provided on the motherboard. Make sure that you press the locking elements down into the holes as far as they will go.
 6. Connect the supply cable to the motherboard.
 7. Turn the locking elements in the opposite direction of the arrows shown on them to lock the cooler onto the motherboard.
- ⇒ You have replaced the CPU cooler.

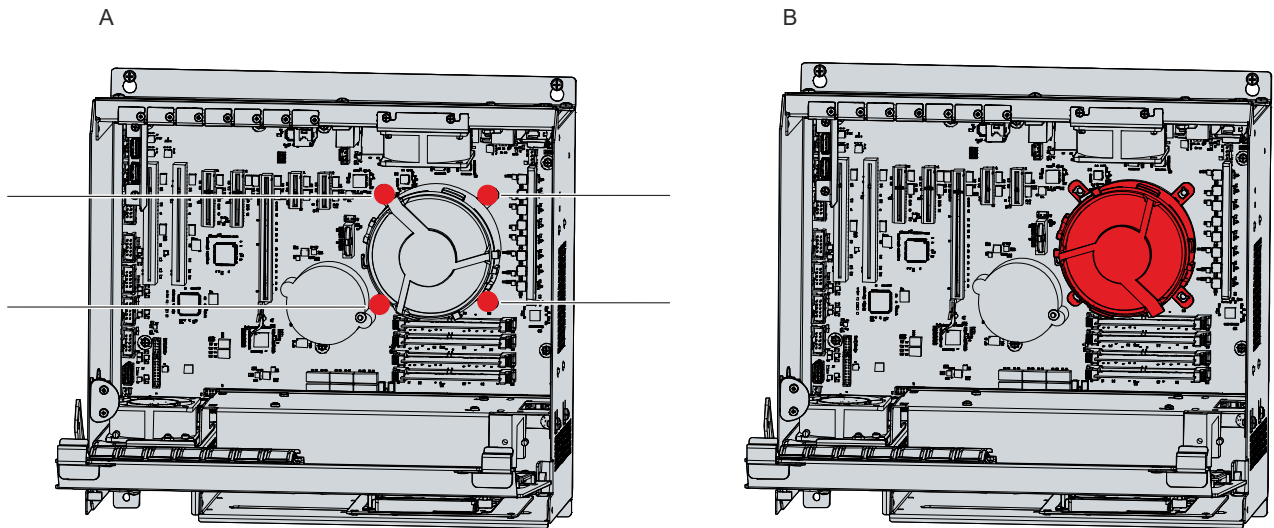

Fig. 23: Exchange CPU cooler

The old fan must be disposed of in accordance with the national electronic waste regulations.

8 Troubleshooting

Fault	Cause	Measures
No function of the device	No power supply to the device Other cause	Check the power supply cable Call Beckhoff Service
The device does not boot fully	BIOS setup settings are incorrect Other causes	Check BIOS setup settings (load defaults) Call Beckhoff Service
The device boots, software starts, but control does not operate correctly	The cause of the error is the software or plant parts outside of the device	Call the machine and software manufacturer
USB error during access with TwinCAT via USB	Cycle times in TwinCAT set to 10 ms (default)	Increase the cycle times to between 50 ms and 80 ms

9 Technical data

Table 17: Technical data

Product designation	CP6500-2000-0100
Dimensions (W x H x D)	332.5 x 309.3 x 162.6 mm
Weight	8.5 kg basic configuration
Supply voltage	22-30 VDC, max. 10 A
Power consumption	Data sheet for power consumption and power loss in the download finder: https://www.beckhoff.com/en-en/support/download-finder/search-result/?download_group=691754572
Secure element	fTPM 2.0 activated (see TPM documentation)
Protection rating	IP20
Overvoltage category	II
Pollution degree	2
Protection class	III
Vibration resistance (sinusoidal vibration)	EN 60068-2-6: 10 to 58 Hz: 0.035 mm 58 to 500 Hz: 0.5 G (approx. 5 m/s ²)
Shock resistance (shock)	EN 60068-2-27: 5 G (approx. 50 m/s ²), duration: 30 ms
EMC interference immunity	conforms to EN 61000-6-2
EMC interference emission	conforms to EN 61000-6-4
Permissible ambient temperature	+0 °C...+50 °C (operation) -25 °C...+65 °C (transport/storage)
Permissible air humidity	Maximum 95 %, no condensation
Transport and storage	The values for air humidity and shock resistance are to be observed during transport and storage and in operation. The shock resistance during transport can be improved by means of suitably packing the industrial PC.

10 Appendix

In the appendix you will find information for servicing and details of the approvals that your device has.

10.1 Service and support

Beckhoff and its worldwide subsidiaries offer comprehensive service and support, providing fast and competent assistance for all issues relating to Beckhoff products and system solutions.

Beckhoff Service

The Beckhoff Service Center provides support in all forms of after-sales service:

- on-site service
- repair service
- spare parts service
- hotline service

Hotline: + 49 5246/963-460
email: service@beckhoff.com

If your device requires attention, please state its serial number, which you can find on the name plate.

Beckhoff Support

Support offers you comprehensive technical assistance to help you with the application of individual Beckhoff products, and also with other extensive services:

- world-wide support
- design, programming, and commissioning of complex automation systems
- extensive training program for Beckhoff system components

Hotline: + 49 5246/963-157
email: support@beckhoff.com

Headquarters

Beckhoff Automation GmbH & Co. KG
Hülshorstweg 20
33415 Verl
Germany

Phone: + 49 5246/963-0
email: info@beckhoff.de

The addresses of the worldwide Beckhoff branches and agencies can be found on our website at <http://www.beckhoff.com/>.

You can also find further documentation for Beckhoff components there.

10.2 Approvals

Your device has at least the following approvals:

- CE
- EAC
- UKCA
- FCC

You will find all other applicable approvals on the name plate of your device.

FCC approvals for the United States of America

FCC: Federal Communications Commission Radio Frequency Interference Statement

This device was tested and complies with the limits for a digital device of class A, according part 15 of the FCC regulations. These limits are designed to provide adequate protection against adverse interference, if the device is used in a commercial environment. This device generates, uses and may emit radio frequency energy and may cause adverse interference with radio communications, if it is not installed and used in accordance with the operating instructions. If this device is used in a residential area it is likely to cause adverse interference, in which case the user must take appropriate countermeasures in order to eliminate the interference at his own expense.

FCC approvals for Canada

FCC: Canadian Notice

This device does not exceed the class A limits for radiation, as specified by the Radio Interference Regulations of the Canadian Department of Communications.

List of figures

Fig. 1	Structure.....	10
Fig. 2	Voltage socket pin numbering.....	11
Fig. 3	Socket external wiring pin numbering	11
Fig. 4	PS/2 mouse and keyboard.....	12
Fig. 5	Audio connections.....	17
Fig. 6	Jack plug pin assignment.....	17
Fig. 7	Name plate.....	18
Fig. 8	Mounting concept.....	20
Fig. 9	Dimensions	21
Fig. 10	Control cabinet installation	22
Fig. 11	Assembly of the strain relief housing	24
Fig. 12	Disassembly of the strain relief housing.....	24
Fig. 13	Grounding bolt for functional earthing	25
Fig. 14	Wiring diagram	27
Fig. 15	Beckhoff Device Manager – Change passwords	30
Fig. 16	Beckhoff Device Manager – Start page	31
Fig. 17	Removal from the control cabinet	33
Fig. 18	Access to device components.....	36
Fig. 19	Replacing the battery	37
Fig. 20	Replacing the storage media	38
Fig. 21	Exchange fan top	39
Fig. 22	Exchange fan bottom	40
Fig. 23	Exchange CPU cooler.....	41

List of tables

Table 1	Legend: CP6500-2000-0100 structure.....	10
Table 2	Voltage socket (X101) pin assignment.....	11
Table 3	Socket external wiring (X102) pin assignment.....	12
Table 4	PS/2 interface mouse pin assignment.....	12
Table 5	PS/2 interface keyboard pin assignment.....	12
Table 6	USB interface pin assignment.....	13
Table 7	Ethernet interface pin assignment.....	14
Table 8	DVI interface pin assignment.....	15
Table 9	RS232 pin assignment.....	15
Table 10	Pin assignment of DisplayPort.....	16
Table 11	Jack plug pin assignment.....	17
Table 12	Meaning LEDs.....	17
Table 13	Legend: name plate CP6500-2000-0100.....	18
Table 14	Order identifier battery pack.....	26
Table 15	Device component replacement recommendations.....	35
Table 16	Technical data of the battery.....	37
Table 17	Technical data.....	43

Trademark statements

Beckhoff®, TwinCAT®, TwinCAT/BSD®, TC/BSD®, EtherCAT®, EtherCAT G®, EtherCAT G10®, EtherCAT P®, Safety over EtherCAT®, TwinSAFE®, XFC®, XTS® and XPlanar® are registered trademarks of and licensed by Beckhoff Automation GmbH.

Third-party trademark statements

Intel, the Intel logo, Intel Core, Xeon, Intel Atom, Celeron and Pentium are trademarks of Intel Corporation or its subsidiaries.

Microsoft, Microsoft Azure, Microsoft Edge, PowerShell, Visual Studio, Windows and Xbox are trademarks of the Microsoft group of companies.

Beckhoff Automation GmbH & Co. KG
Hülshorstweg 20
33415 Verl
Germany
Phone: +49 5246 9630
info@beckhoff.com
www.beckhoff.com