

BECKHOFF New Automation Technology

Manual | EN

CP62xx

Panel PC



Table of contents

1	Notes on the documentation	5
2	For your safety	6
2.1	Signal words	6
2.2	Intended use	6
2.3	Fundamental safety instructions	7
2.4	Operator's obligation to exercise diligence	7
2.5	Notes on information security	8
3	Product overview	9
3.1	Structure	11
3.2	Interface description	12
3.2.1	RS232	13
3.2.2	DVI	14
3.2.3	USB	15
3.2.4	Ethernet RJ45	16
3.2.5	Power supply	18
3.3	Optional interfaces	19
3.3.1	PCIe® module FC9062 with 2 Gigabit Ethernet ports	20
3.3.2	PCIe® module C9900-E301 with 2 serial interfaces RS232	21
3.3.3	PCIe® module C9900-E309 with 2 serial interfaces RS485	22
3.3.4	PCIe® module C9900-E310 with 2 serial interfaces RS422	23
3.3.5	PCIe® module C9900-E277 with 2 USB 3.0 interfaces	24
3.3.6	C9900-E159 with 1 serial interface RS232	25
3.3.7	C9900-E188 with 1 serial interface RS485	25
3.3.8	C9900-E189 with 1 serial interface RS422	26
3.3.9	C9900-E234 with 2 USB 2.0 interfaces	27
3.3.10	FC9071-0000 Gigabit Ethernet PC network card with 1 channel	28
3.4	Name plate	29
3.5	Key functions	31
4	Commissioning	33
4.1	Transport and unpacking	34
4.2	Control cabinet installation	35
4.3	Connecting the panel PC	37
4.3.1	Mounting power supply cable	38
4.3.2	Grounding the panel PC	40
4.3.3	Connecting cables and power supply	41
4.4	Switching the panel PC on and off	42
5	Configuration	44
5.1	Beckhoff Device Manager	44
5.2	UPS configuration	45
6	Decommissioning	48
6.1	Disconnecting the power supply and cables	48
6.2	Disassembly and disposal	49
7	Maintenance	50

7.1	Cleaning	50
7.2	Maintenance.....	52
7.2.1	Replacing the battery	54
7.2.2	Replacing the storage media	55
7.2.3	Replacing the fan	58
8	Troubleshooting	59
9	Technical data	60
10	Appendix.....	61
10.1	Service and support	61
10.2	Approvals	62

1 Notes on the documentation

This description is only intended for the use of trained specialists in control and automation engineering who are familiar with the applicable national standards.

The following instructions and explanations must be followed during installation and commissioning of the components. The responsible staff must ensure that the application or use of the products described satisfy all the requirements for safety, including all the relevant laws, regulations, guidelines and standards.

Disclaimer

The documentation has been prepared with care. The products described are, however, constantly under development. For that reason the documentation is not in every case checked for consistency with performance data, standards or other characteristics. In the event that it contains technical or editorial errors, we retain the right to make alterations at any time and without warning. No claims for the modification of products that have already been supplied may be made on the basis of the data, diagrams, and descriptions in this documentation. All illustrations shown are only examples. The configurations depicted may deviate from the standard.

Trademarks

Beckhoff®, TwinCAT®, TwinCAT/BSD®, TC/BSD®, EtherCAT®, EtherCAT G®, EtherCAT G10®, EtherCAT P®, Safety over EtherCAT®, TwinSAFE®, XFC®, XTS® and XPlanar® are registered and licensed trademarks of Beckhoff Automation GmbH.

Other designations used in this publication may be trademarks whose use by third parties for their own purposes could violate the rights of the owners.

Patents

The EtherCAT Technology is covered, including but not limited to the following patent applications and patents: EP1590927, EP1789857, EP1456722, EP2137893, DE102015105702 and similar applications and registrations in several other countries.

Copyright

© Beckhoff Automation GmbH & Co. KG. Publication of this document on websites other than ours is prohibited. Offenders will be held liable for the payment of damages. All rights reserved in the event of the grant of a patent, utility model or design.

Delivery state

All the components are supplied in particular hardware and software configurations appropriate for the application. Changes to the hardware or software configuration are permitted, provided they are within the specified limits for power consumption and power loss (please refer to the respective data sheet).

Currentness

Please check whether you are using the current and valid version of this document. The current version is always available for download from the Beckhoff website. In case of doubt, contact Technical Support.

Delivery conditions

In addition, the general delivery conditions of the company Beckhoff Automation GmbH & Co. KG apply.

2 For your safety

The signal words and their meanings are explained in the chapter on safety. They contain fundamental safety instructions that are essential for preventing personal injuries and damage to property.

Exclusion of liability

Beckhoff shall not be held liable in the event that this documentation is not complied with and the devices are therefore not used in line with the documented operating conditions.

2.1 Signal words

The signal words used in the documentation are classified below.

Warning on personal injuries

⚠ DANGER
High-risk hazard that will result in death or serious injury.
⚠ WARNING
Medium-risk hazard that may result in death or serious injury.
⚠ CAUTION
Low-risk hazard that may result in minor injury.

Warning on property and environmental damage

NOTICE
The environment, equipment, or data may be damaged.

2.2 Intended use

The device is intended for use as a control system for automation, visualization and communication in machine and system engineering.

The Front side of the device is designed for an IP65 working environment. It offers full protection against contact and against dust, as well as protection against water jets (nozzle) from any angle.

The Rear side is designed for an IP20 working environment. It is protected against the penetration of fingers and solid foreign bodies of 12.5 mm in diameter or larger in size. It is not protected against water. Operation of the device in wet and dusty environments is not permitted.

The specified limits for technical data must be adhered to.

The device can be used within the documented operating conditions.

Improper use

Do not use the device outside the documented operating conditions.

2.3 Fundamental safety instructions

The following safety instructions must be observed when handling the device.

Application conditions

- Do not use the device under extreme environmental conditions.
- Only use the device in hazardous areas if it is explicitly designed for this purpose.
- Never plug or unplug connectors during thunderstorms. There is a risk of electric shock.
- Ensure that the device has a protective and functional earth connection.

Damage to property, loss of data and impairment of functions

- If you change the hardware and software configurations, you must keep within the specified limits of power consumption and power loss (please refer to the respective data sheet).
- Ensure that only trained specialists with a control and automation engineering background, operate the device. Use by unauthorized persons can lead to damage to property and loss of data.
- In the case of a 24 V DC power supply unit, fuse the power supply line according to its cross-section to protect the supply line in the event of a short circuit.
- In case of fire, extinguish the device with powder or nitrogen.

2.4 Operator's obligation to exercise diligence

The operator must ensure that

- the products are used only for their intended purpose (see Chapter 2.2 [Intended use](#) [▶ 6]).
- the products are only operated in sound condition and in working order.
- the products are operated only by suitably qualified and authorized personnel.
- the personnel is instructed regularly about relevant occupational safety and environmental protection aspects, and is familiar with the operating instructions and in particular the safety instructions contained herein.
- the operating instructions are in good condition and complete, and always available for reference at the location where the products are used.

2.5 Notes on information security

The products of Beckhoff Automation GmbH & Co. KG (Beckhoff), insofar as they can be accessed online, are equipped with security functions that support the secure operation of plants, systems, machines and networks. Despite the security functions, the creation, implementation and constant updating of a holistic security concept for the operation are necessary to protect the respective plant, system, machine and networks against cyber threats. The products sold by Beckhoff are only part of the overall security concept. The customer is responsible for preventing unauthorized access by third parties to its equipment, systems, machines and networks. The latter should be connected to the corporate network or the Internet only if appropriate protective measures have been set up.

In addition, the recommendations from Beckhoff regarding appropriate protective measures should be observed. Further information regarding information security and industrial security can be found in our <https://www.beckhoff.com/secguide>.

Beckhoff products and solutions undergo continuous further development. This also applies to security functions. In light of this continuous further development, Beckhoff expressly recommends that the products are kept up to date at all times and that updates are installed for the products once they have been made available. Using outdated or unsupported product versions can increase the risk of cyber threats.

To stay informed about information security for Beckhoff products, subscribe to the RSS feed at <https://www.beckhoff.com/secinfo>.

3 Product overview

The CP62xx built-in Panel PC series is designed for installation in the front of a control cabinet and represents a powerful platform for use in machine and system engineering.

You can use the panel PC for the following applications, among others:

- various automation and visualization tasks
- wide range of IoT tasks, for example when used as an IoT gateway
- simple HMI applications
- axis control
- short cycle times
- high-volume data handling

The panel PC is available in the following five display sizes, with corresponding resolutions:

- 12-inch (800 x 600) 4:3
- 15-inch (1024 x 768) 4:3
- 19-inch (1280 x 1024) 5:4

In its basic configuration, the device includes the following features:

- 3½-inch motherboard
- Intel® processor
- DDR4-RAM
- 2½-inch hard disk/SSD
- 1 slot for 2½-inch hard disk/SSD
- 1 slot for CFast
- 24 V DC power supply unit

You can order your device without keys, with function keys, with a numerical keypad or with an alphanumeric keypad. Information on the key functions can be found in chapter 3.5 [Key functions](#) [► 31].

You can optionally order your device with additional PCIe® module slots or PCI/PCIe® plug-in card slots.

Table 1: Device extension options

Order number	Description	Link to options
C9900-B500	2 PCIe® module slots	https://www.beckhoff.com/cp62xx
C9900-B504	2 PCIe® plug-in card slots	Select a product variant and then select the "Options" tab at the bottom of the website.
C9900-B508	2 PCI plug-in card slots	
C9900-B512	1 PCI and 1 PCIe® plug-in card slot	

The additional module and plug-in card slots change the depth of the backplane cover. With module slots, the depth increases by 30 mm, with the various plug-in card slots by 66 mm.

Figure 1 shows an example of a CP62xx without extension (1), with PCIe® module slots (2) and with PCI/PCIe® plug-in card slots (3).

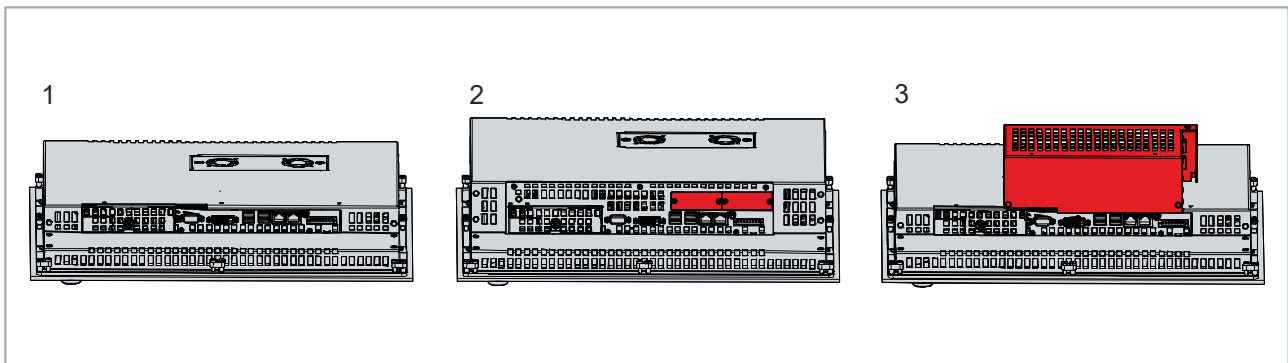

Fig. 1: Comparison of device extensions

For more information on the interface options provided by the PCIe[®] module slots, please refer to chapter 3.3 [Optional interfaces](#) [► 19].

An overview of the PCI and PCIe[®] plug-in cards is available [here](#).

3.1 Structure

Figure 2 shows an example of the basic configuration of a CP62xx.



Fig. 2: Structure

Table 2: Legend structure

No.	Component	Description
1	Clamping lever	Mounting the device in the control cabinet wall
2	Fan cartridge	Optimum cooling of the inside of the device
3	Name plate	Information on the equipment of the device
4	Connection section	Access to interfaces
5	Display and touch screen glass	Operating the device

3.2 Interface description

In the basic configuration, the built-in panel PC includes the following interfaces:

- RS232 (X102)
- DVI (X103)
- USB (X104 - X107)
- Ethernet (X108, X109)
- Power supply (X110)

The interfaces are located at the rear of the device (see fig. 3). Regardless of whether the device is equipped with module or plug-in card slots, the interfaces are located in the same place.

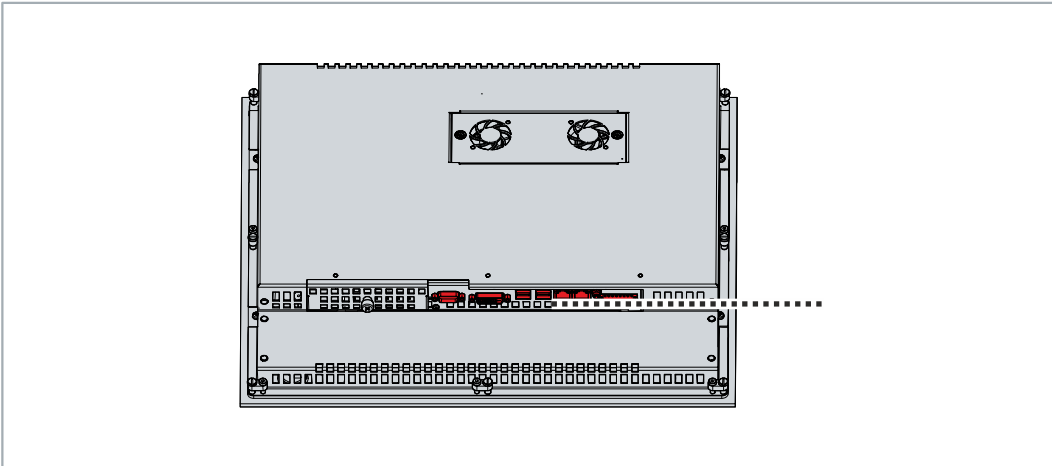

Fig. 3: Connection section

3.2.1 RS232

The serial interface COM1 (X102) is fed out via a 9-pin standard DSUB connector. The interface provides an asynchronous, serial communication method defined in the RS232 standard.

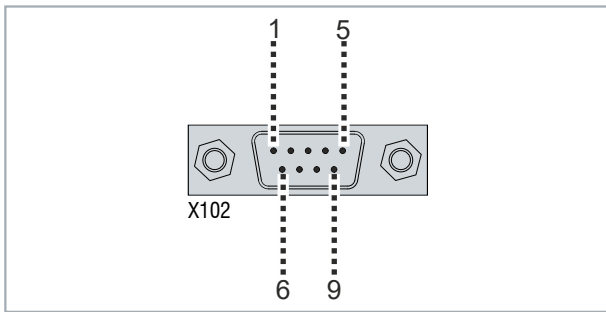

Fig. 4: RS232 interface pin numbering

Table 3: RS232 interface pin numbering

Pin	Name	Description
1	DCD	Data Carrier Detect
2	RXD	Receive Data
3	TXD	Transmit Data
4	DTR	Data Terminal Ready
5	GND	Ground
6	DSR	Data Set Ready
7	RTS	Request to Send
8	CTS	Clear to Send
9	RI	Ring Indicator

3.2.2 DVI

The panel PC is equipped with a DVI connector (X103), to which a DVI-capable monitor can be connected. Only digital signals are transmitted.

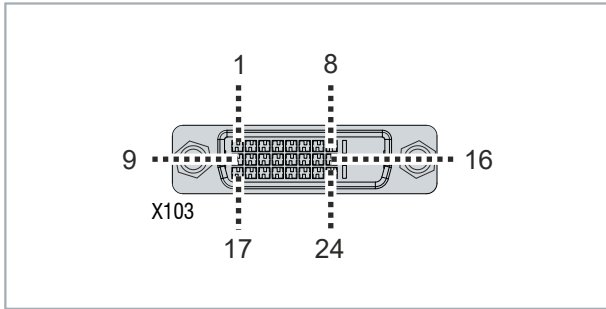

Fig. 5: DVI interface pin numbering

Table 4: DVI interface pin assignment

Pin	Connection	Pin	Connection	Pin	Connection
1	TMDS Data 2 -	9	TMDS Data 1 -	17	TMDS Data 0 -
2	TMDS Data 2 +	10	TMDS Data 1 +	18	TMDS Data 0 +
3	TMDS Data 2/4 Shield	11	TMDS Data 1/3 Shield	19	TMDS Data 0/5 Shield
4	not connected	12	not connected	20	not connected
5	not connected	13	not connected	21	not connected
6	DDC Clock	14	+ 5 V Power	22	TMDS Clock Shield
7	DDC Data	15	Ground (+ 5 V, Analog H/V Sync)	23	TMDS Clock +
8	Analog Vertical Sync	16	Hot Plug Detect	24	TMDS Clock -

3.2.3 USB

The panel PC has four USB interfaces (X104, X107). They are used to connect peripheral devices with USB interfaces. The following table shows the interface assignment based on the device generation:

Table 5: USB interface device generation

Device generation	USB interfaces
CP62xx-xxxx-0070	4x USB 3.0 (X104-X107)
CP62xx-xxxx-0080	4x USB 3.0 (X104-X107)
CP62xx-xxxx-0090	4x USB 3.2 Gen. 2 (X104-X107)

Each of the four USB interfaces can supply up to 900 mA of current and are electronically fused.

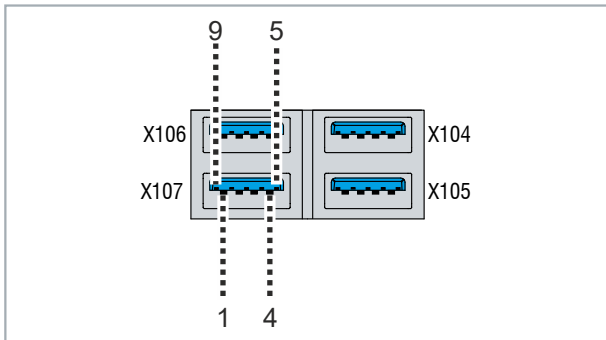

Fig. 6: USB interface pin numbering

Table 6: USB interface pin assignment

Pin	Connection
1	Vbus
2	D -
3	D +
4	GND
5	StdA_SSRX -
6	StdA_SSRX +
7	GND_DRAIN
8	StdA_SSTX -
9	StdA_SSTX +

3.2.4 Ethernet RJ45

The panel PC has two Gigabit LAN ports (X108, X109). The Ethernet standards 100Base-T, 1000Base-T and 2500Base-T enable the connection of corresponding network components and data rates of 100/1000/2500 Mbit/s. The required speeds are selected automatically.

The RJ45 connection technology with twisted-pair cables is used. The maximum length of the cable connection is 100 m.

The controllers are used as follows, based on the device generation:

Table 7: Controller classification based on device generation

Device generation	Controller	Mbit/s
CP62xx-xxxx-0070	Intel® i219 for LAN2 and Intel® i210 for LAN1	100/1000
CP62xx-xxxx-0080	Intel® i219 for LAN2 and Intel® i210 for LAN1	100/1000
CP62xx-xxxx-0090	Intel® i219 for LAN2 and Intel® i226 for LAN1	100/1000/2500

The Ethernet port (X108, LAN1) connected via PCIe® with the i210/i226 controller is suitable for cycle times <= 1 ms and for distributed clock applications with EtherCAT.

The Ethernet port (X109, LAN2) integrated in the chipset with the i219 controller is suitable for real-time Ethernet applications with cycle times > 1 ms (without distributed clocks).

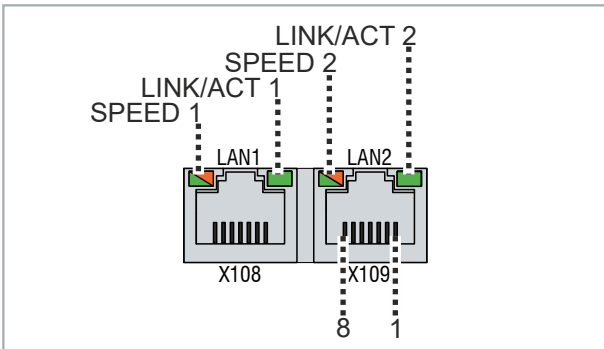

Fig. 7: Ethernet interface pin numbering

Table 8: Ethernet interface pin assignment

Pin	Signal	Description
1	T2 +	Pair 2
2	T2 -	
3	T3 +	Pair 3
4	T1 +	Pair 1
5	T1 -	
6	T3 -	Pair 3
7	T4 +	Pair 4
8	T4 -	

The LEDs of the LAN interfaces indicate the activity and the data transmission rate (Mbit/s). The LED (LINK/ACT) shown completely green in the figure indicates whether the interface is connected to a network. If this is the case, the LED lights up green. The LED flashes green when data transmission is in progress on the interface.

The green/orange LED (SPEED) shown in the figure indicates the data transmission rate. The device generations differ in terms of the possible data transmission rate. The following tables show what the LEDs mean with regard to the potential data transmission rate.

Table 9: LED meaning: speed 100/1000 Mbit/s

Mbit/s	LED
100	Lights up orange
1000	Lights up green

Table 10: LED meaning: speed 100/1000/2500 Mbit/s

Mbit/s	LED
100	Off
1000	Lights up orange
2500	Lights up green

3.2.5 Power supply

The panel PC is supplied with a nominal voltage of 24 V. The connection to the power supply and the external wiring of the device are made via the 8-pin voltage socket (X110). The main supply voltage is applied between PIN 5 (0 V) and PIN 6 (+24 V) of the socket. If the device is equipped with an integrated uninterruptible power supply (UPS), an external battery pack can also be connected to PIN 1 and PIN 2.

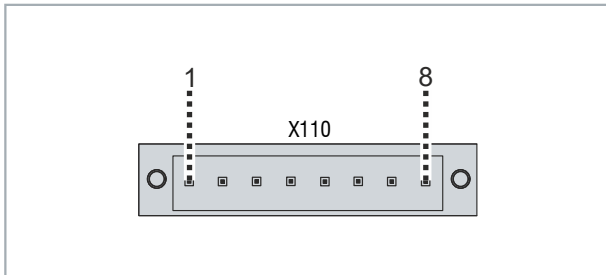

Fig. 8: Power supply pin numbering

Table 11: Voltage socket pin assignment

Pin	Signal	Description
1	- BAT	Negative pole of the battery pack
2	+ BAT	Positive pole of the battery pack
3	24 V UPS	24 V UPS output 2.5 A, minus is – BAT
4	⊕	Protective earth
5	-	24 V supply voltage, negative pole
6	+ 24 V	24 V supply voltage, positive pole
7	PC-ON	Input PC-ON
8	P-S	Power Status output, minus is the negative pole of the supply voltage

To operate the buffered 24 V output, you must use PIN 1 (-) and PIN 3 (+).

The plug for the power supply is specified for 8 A and can accommodate wire cross-sections of up to 1.5 mm². For long supply lines, use 1.5 mm² cables to achieve a low voltage drop on the supply lines. At least 22 V should be present at the power supply plug of the device so that the device remains switched on in the event of voltage fluctuations. The plug is included in the delivery. You can obtain a replacement plug from your Beckhoff Sales using the following ordering option: C9900-P926

3.3 Optional interfaces

You have the option of adding optional interfaces to your device. On the one hand, you can do this using PCIe® modules. This requires the device to be equipped with two PCIe® module slots (C9900-B500). The depth of the backplane cover of the device is increased by 30 mm due to the module slots. On the other hand, you can order additional interfaces ex factory, which are led out in the connection section of the device.

To install a PCIe® module in your device, you must first remove the panels. To do this, remove the two M3 screws from the panels.

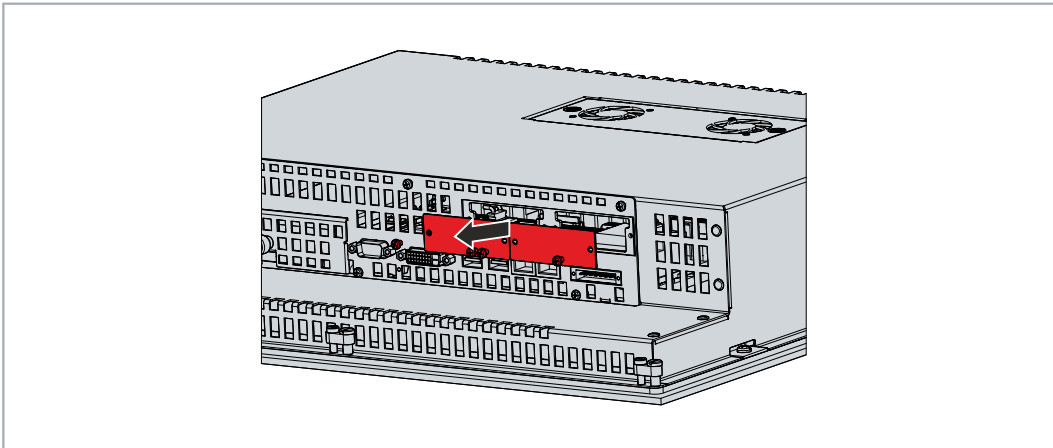

Fig. 9: Installation of PCIe® modules

You can order the following PCIe® modules for your device:

Table 12: Options PCIe® modules

Order number	Description	Link to option
FC9062	Gigabit Ethernet PCIe® module	https://www.beckhoff.com/cp62xx
C9900-E301	RS232 PCIe® module	Select a product variant and then select the "Options" tab at the bottom of the website.
C9900-E309	RS485 PCIe® module	
C9900-E310	RS422 PCIe® module	
C9900-E277	USB 3.0 PCIe® module	

You can order the following interfaces ex factory for the connection section:

Table 13: Options Interfaces Connection section

Order number	Description	Link to option
C9900-E159	Serial interface RS232	https://www.beckhoff.com/cp62xx
C9900-E188	Serial interface RS485	Select a product variant and then select the "Options" tab at the bottom of the website.
C9900-E189	Serial interface RS422	
C9900-E234	2 USB ports	
FC9071-0000	Gigabit Ethernet PC network card	

You can only order one serial interface as an option.

3.3.1 PCIe® module FC9062 with 2 Gigabit Ethernet ports

The Ethernet standards 100Base-T and 1000Base-T enable the connection of corresponding network components and data rates of 100/1000 Mbit/s for the two Ethernet ports of the FC9062 option connected via PCIe®. The required speeds are selected automatically.

The RJ45 connection technology with twisted-pair cables is used. The maximum length of the cable connection is 100 m.

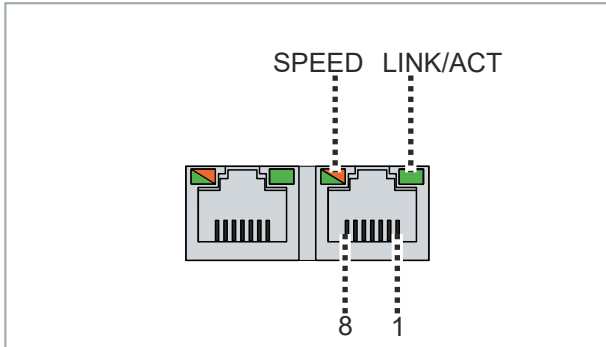

Fig. 10: Ethernet interface pin numbering

Table 14: Ethernet interface pin assignment

Pin	Signal	Description
1	T2 +	Pair 2
2	T2 -	
3	T3 +	Pair 3
4	T1 +	
5	T1 -	Pair 1
6	T3 -	
7	T4 +	Pair 4
8	T4 -	

The LEDs of the LAN interfaces indicate the activity and the data transmission rate (Mbit/s). The LED (LINK/ACT) shown completely green in the figure indicates whether the interface is connected to a network. If this is the case, the LED lights up green. The LED flashes green when data transmission is in progress on the interface.

The green/orange LED (SPEED) shown in the figure indicates the data transmission rate. If the speed is 100 Mbit/s the LED is orange, at 1000 Mbit/s it is green.

3.3.2 PCIe® module C9900-E301 with 2 serial interfaces RS232

The RS232 interfaces contain two electrically isolated sockets ix Industrial® type B. Two adapter cables ix Industrial® type B to D-sub, 9-pin are required (order identifier C9900-K920). The adapter cables are 50 cm long. The interface provides an asynchronous, serial communication method defined in the RS232 standard.

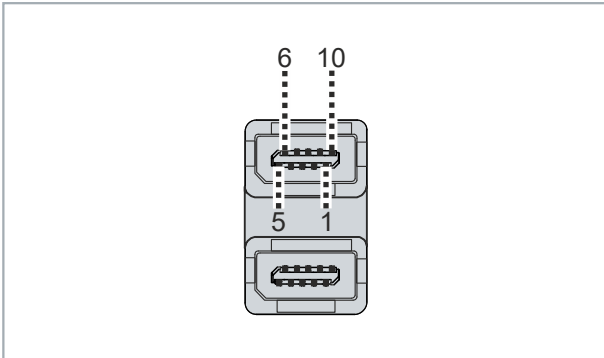

Fig. 11: RS232 interface pin numbering

Table 15: RS232 interface pin numbering

Pin	Name	Description
1	DCD	Data Carrier Detect
2	RXD	Receive Data
3	TXD	Transmit Data
4	DTR	Data Terminal Ready
5	GND	Ground
6	DSR	Data Set Ready
7	RTS	Request to Send
8	CTS	Clear to Send
9	RI	Ring Indicator

3.3.3 PCIe® module C9900-E309 with 2 serial interfaces RS485

The RS485 PCIe® module contains two electrically isolated ix Industrial® type B sockets for asynchronous, serial high-speed data transmission. Two ix Industrial® type B to D-sub, 9-pin adapter cables are required (order identifier C9900-K922). The adapter cables are 50 cm long. The signal transfer takes place symmetrically.

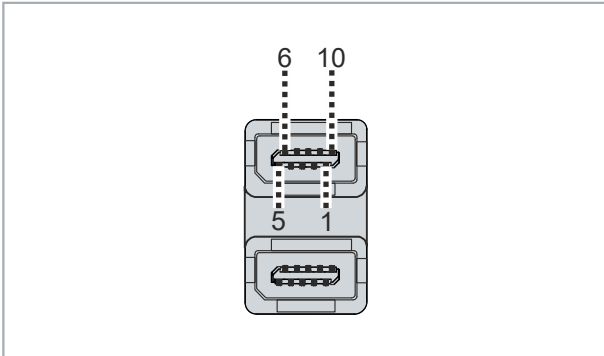

Fig. 12: RS485 interface pin numbering

Table 16: RS485 pin assignment

Pin	Signal	Type	Description
1	N/C	-	Not used
2	TxD +	Data-Out +	Transmit 485
3	RxD +	Data-In +	Receive 485
4	N/C	-	Not used
5	GND	Ground	Ground
6	VCC	VCC	+5 V
7	TxD-	Data-Out -	Transmit 485
8	RxD-	Data-In -	Receive 485
9	N/C	-	Not used
10	N/C	-	Not used

Pins 2 and 3 (data +) and pins 7 and 8 (data -) must be connected.

On delivery the interface is configured as a half-duplex endpoint without echo as standard – see table below:

Table 17: RS485 standard configuration

Function	Status
Echo	off
Auto send	on
Always send	off
Auto receive	on
Always receive	off
Termination	on

3.3.4 PCIe® module C9900-E310 with 2 serial interfaces RS422

The RS422 PCIe® module contains two electrically isolated ix Industrial® type B sockets for high-speed serial data transmission. Two ix Industrial® type B to D-sub, 9-pin adapter cables are required (order identifier C9900-K922). The adapter cables are 50 cm long. The signal transfer takes place symmetrically.

The channels are protected by a common overvoltage protection. If an overvoltage occurs at one of the channels, both channels are switched off.

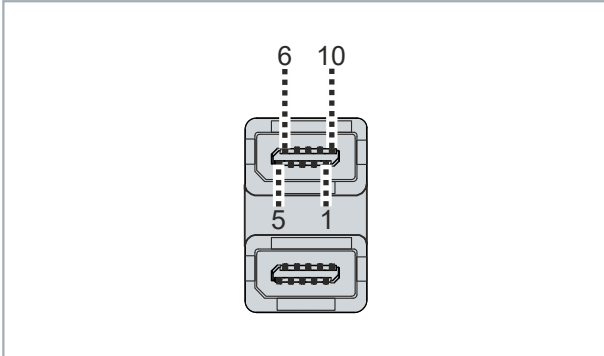

Fig. 13: RS422 interface pin numbering

Table 18: RS422 pin assignment

Pin	Signal	Type	Description
1	N/C	-	Not used
2	TxD +	Data-Out +	Transmit 422
3	RxD +	Data-In +	Receive 422
4	N/C	-	Not used
5	GND	Ground	Ground
6	VCC	VCC	+5 V
7	TxD -	Data-Out -	Transmit 422
8	RxD -	Data-In -	Receive 422
9	N/C	-	Not used
10	N/C	-	Not used

On delivery the interface is configured as a full duplex endpoint as standard:

Table 19: RS422 standard configuration

Function	Status
Echo	on
Auto send	off
Always send	on
Auto receive	off
Always receive	on
Termination	on

3.3.5 PCIe® module C9900-E277 with 2 USB 3.0 interfaces

The USB 3.0 PCIe® module includes two USB ports with a data transmission rate of up to 5 Gbit/s according to the USB 3.0 specification. Each port provides up to 1 A power supply.

They are used to connect peripheral devices with USB interfaces. Compatibility with all USB standards is assured.

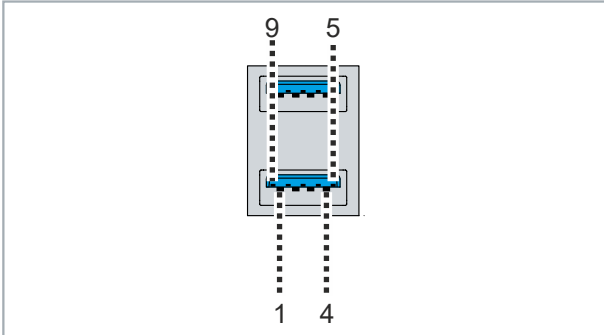

Fig. 14: USB interface pin numbering

Table 20: USB interface pin assignment

Pin	Connection
1	Vbus
2	D -
3	D +
4	GND
5	StdA_SSRX -
6	StdA_SSRX +
7	GND_DRAIN
8	StdA_SSTX -
9	StdA_SSTX +

3.3.6 C9900-E159 with 1 serial interface RS232

The serial interface contains an electrically isolated socket. It is led out via a 9-pin standard DSUB connector. The interface provides an asynchronous, serial communication method defined in the RS232 standard.

The channel features overvoltage protection.

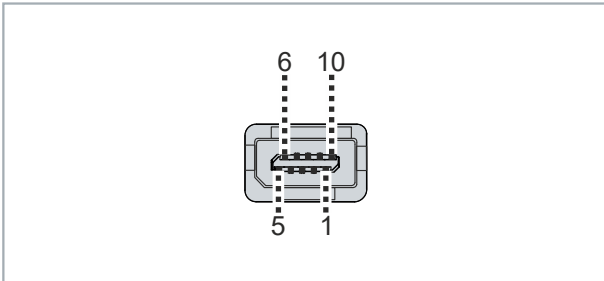

Fig. 15: RS232 interface pin numbering

Table 21: RS232 interface pin numbering

Pin	Name	Description
1	DCD	Data Carrier Detect
2	RXD	Receive Data
3	TXD	Transmit Data
4	DTR	Data Terminal Ready
5	GND	Ground
6	DSR	Data Set Ready
7	RTS	Request to Send
8	CTS	Clear to Send
9	RI	Ring Indicator

3.3.7 C9900-E188 with 1 serial interface RS485

The interface contains an electrically isolated socket. It is led out via a 9-pin standard DSUB connector. The interface provides an asynchronous, serial communication method defined in the RS485 standard.

The channel features overvoltage protection.

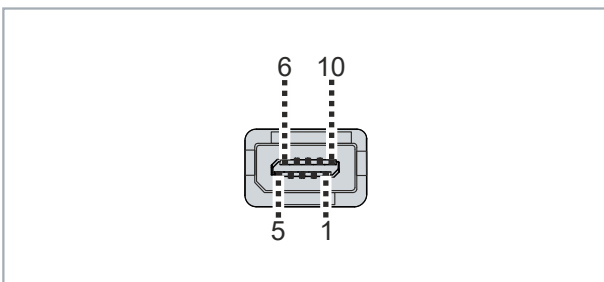

Fig. 16: RS485 interface pin numbering

Table 22: RS485 pin assignment

Pin	Signal	Type	Description
1	N/C	-	Not used
2	TxD +	Data-Out +	Transmit 485
3	RxD +	Data-In +	Receive 485
4	N/C	-	Not used
5	GND	Ground	Ground

Pin	Signal	Type	Description
6	VCC	VCC	+5 V
7	TxD-	Data-Out -	Transmit 485
8	RxD-	Data-In -	Receive 485
9	N/C	-	Not used
10	N/C	-	Not used

Pins 2 and 3 (data +) and pins 7 and 8 (data -) must be connected.

On delivery the interface is configured as a half-duplex endpoint without echo as standard – see table below:

Table 23: RS485 standard configuration

Function	Status
Echo	off
Auto send	on
Always send	off
Auto receive	on
Always receive	off
Termination	on

3.3.8 C9900-E189 with 1 serial interface RS422

The interface contains an electrically isolated socket. It is led out via a 9-pin standard DSUB connector. The interface provides an asynchronous, serial communication method defined in the RS422 standard.

The channel features overvoltage protection.

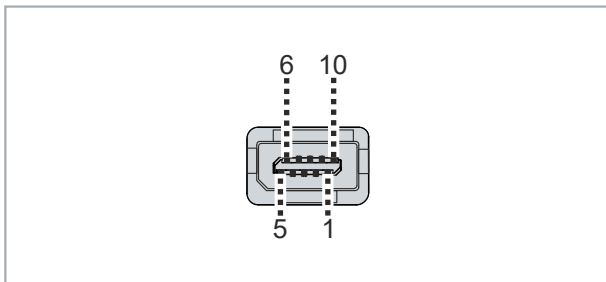

Fig. 17: RS422 interface pin numbering

Table 24: RS422 pin assignment

Pin	Signal	Type	Description
1	N/C	-	Not used
2	TxD +	Data-Out +	Transmit 422
3	RxD +	Data-In +	Receive 422
4	N/C	-	Not used
5	GND	Ground	Ground
6	VCC	VCC	+5 V
7	TxD -	Data-Out -	Transmit 422
8	RxD -	Data-In -	Receive 422
9	N/C	-	Not used
10	N/C	-	Not used

On delivery the interface is configured as a full duplex endpoint as standard:

Table 25: RS422 standard configuration

Function	Status
Echo	on
Auto send	off
Always send	on
Auto receive	off
Always receive	on
Termination	on

3.3.9 C9900-E234 with 2 USB 2.0 interfaces

The option includes two USB 2.0 interfaces. They are used to connect peripheral devices with USB connection.

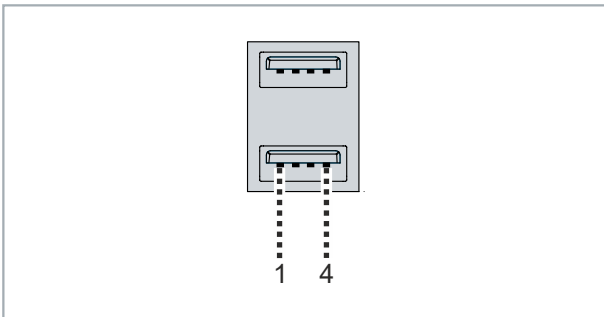

Fig. 18: USB interface pin numbering

Table 26: USB interface pin assignment

Pin	Connection
1	Vbus
2	D -
3	D +
4	GND

3.3.10 FC9071-0000 Gigabit Ethernet PC network card with 1 channel

The 100Base-T and 1000Base-T Ethernet standards enable the connection of corresponding network components and data rates of 100/1000 Mbit/s. The required speed is selected automatically.

The RJ45 connection technology with twisted-pair cables is used. The maximum length of the cable connection is 100 m.

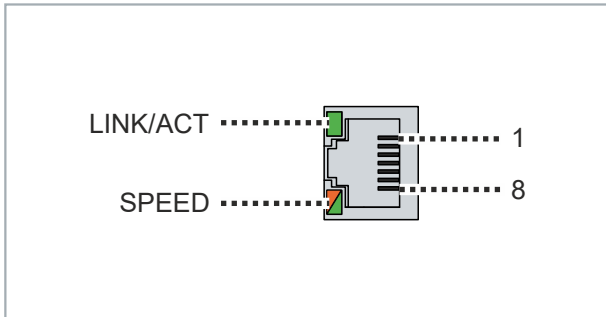

Fig. 19: Gigabit Ethernet PC network card pin numbering

Table 27: Ethernet interface pin assignment

Pin	Signal	Description
1	T2 +	Pair 2
2	T2 -	
3	T3 +	Pair 3
4	T1 +	Pair 1
5	T1 -	
6	T3 -	Pair 3
7	T4 +	Pair 4
8	T4 -	

The LEDs of the LAN interfaces indicate the activity and the data transmission rate (Mbit/s). The LED (LINK/ACT) shown completely green in the figure indicates whether the interface is connected to a network. If this is the case, the LED lights up green. The LED flashes green when data transmission is in progress on the interface.

The green/orange LED (SPEED) shown in the figure indicates the data transmission rate. If the speed is 100 Mbit/s the LED is orange, at 1000 Mbit/s it is green.

3.4 Name plate

The name plate provides information about the equipment of the device. The name plate shown here serves only as an example.

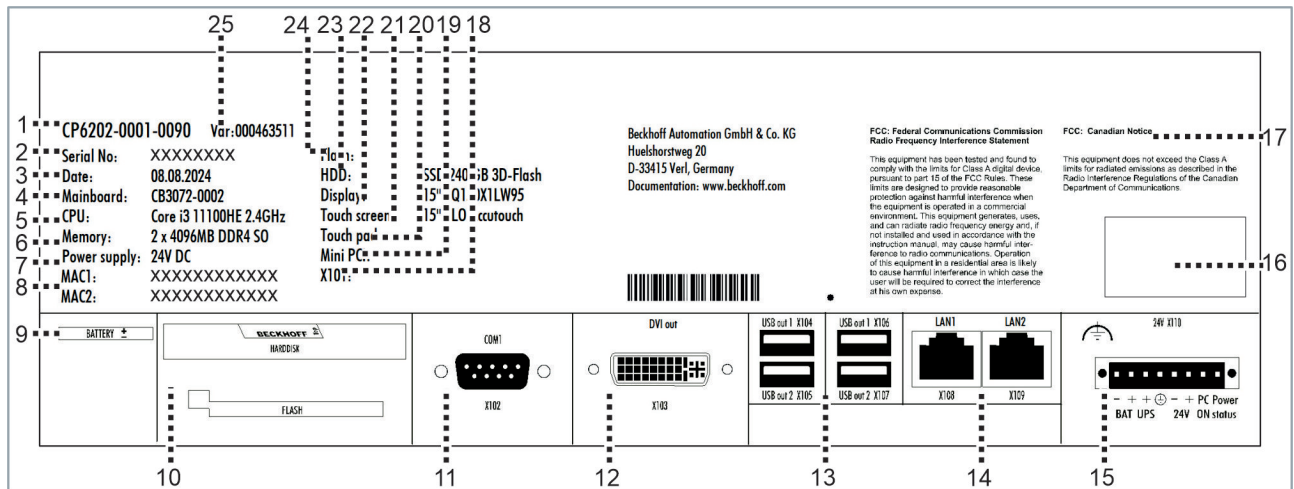



Fig. 20: Name plate













Table 28: Legend name plate



No.	Description
1	Model: the last four digits indicate the device generation.
2	Serial number = Beckhoff Traceability Number (BTN)
3	Date of manufacture
4	Mainboard
5	CPU
6	Main memory
7	Power supply
8	MAC addresses of the Ethernet interfaces (X108, X109)
9	Battery
10	Hard disk, CFast
11	Serial interface
12	DVI interface
13	USB interfaces (X104 - X107)
14	Ethernet interfaces (X108, X109)
15	Power supply connection (X110)
16	Symbols <div style="text-align: right;">  </div> <p>Note: Here are the symbols applicable to the device such as CE, EAC, UKCA, . The approvals of your device can be found on the name plate and in chapter 10.2 Approvals [▶ 62].</p>
17	FCC approval
18	Optional additional interface X101
19	Mini PCI
20	Touch pad
21	Touch screen
22	Display
23	Hard disk
24	Storage medium

No.	Description
25	Variant number: commercial number of the order code including ordering options

3.5 Key functions

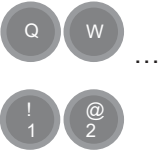
Table 29: Key functions

Key	Function
	Move the cursor one step in the corresponding direction
	<i>Home</i> = cursor to beginning of the line <i>End</i> = cursor to end of the line
	<i>Pg Up</i> = scroll forward one page <i>Pg Dn</i> = turn back one page
	<i>Tabulator</i> = cursor to next input field <i>Shift + Tab</i> = cursor to previous input field
	<i>Del</i> = delete character to the right of the cursor
	<i>Enter</i> = confirm input
	<i>Backspace</i> = delete character to the left of the cursor
	<i>Shift</i> pressed with letter = upper case instead of lower case letter <i>Shift</i> pressed with number = displayed character instead of number
	<i>Caps Lock</i> = permanent pressing of the <i>Shift</i> key (pressing the <i>Shift</i> key deactivates the function)
	<i>Ctrl, Alt</i> = change the meaning of a key pressed at the same time
	Open the start menu of the operating system in use
	Opening the properties window of a selected object
	<i>Esc</i> = close dialog box, cancel operations
	Set printed character to the cursor position

	<p><i>Function keys</i> = functions of the keys determined by the software</p>
	<p><i>Special keys</i> = special keys with LED that can be controlled by the TwinCAT automation software</p>

4 Commissioning

In order to use the panel PC, you must first commission it. The first step is to transport the device to its operating location and unpack it. This is followed by installing the device in the control cabinet front, connecting the cables and the power supply and finally switching on the panel PC.

Operating the device

The device is operated via the touch screen.

NOTICE

Damage to the touch screen

Operating the touch screen with unsuitable objects may damage the touch screen.

- Operate the touch screen only with bare fingers or wearing suitable gloves.
- If you use gloves, make sure that no hard particles such as metal shavings, glass splinters or similar adhere to the glove.

If you, as the user, require additional protection for the touch screen against dirt and scratching, for example due to dirty hands, this can be achieved with a protective film. The film provides short-term protection for a few days.

You can either order a protective film individually and fit it yourself retrospectively, or you can order the film for fitting directly ex factory. The protective films available for the display size of your device can be found on the Beckhoff website.

Proceed as follows to attach the protective film to the touch screen:

1. Ensure that the environment is as dust-free as possible.
 2. Thoroughly clean the surface of the device to be fitted with the film and remove all grease residues.
 3. Detach the film from the backing at the short edge and place it on the surface.
 4. Gradually remove the film from the backing. At the same time, use a doctor blade or other object with a soft rubber or felt edge to apply the film.
 5. Brush away air bubbles towards the edge with a doctor blade or other object with a soft rubber or felt edge.
- ⇒ The film is now fitted.

You can use the Dimming, Screensaver and Cleaning mode functions with the Display Control Tool. The Beckhoff Information System provides more information about the tool: <https://infosys.beckhoff.com/content/1031/panelconfigurationtools/11725543179.html?id=7993182328699786200>.

4.1 Transport and unpacking

The specified storage conditions must be observed (see chapter 9 [Technical data \[►_60\]](#)).

Despite the robust design of the unit, the components are sensitive to strong vibrations and impacts. During transport the device must therefore be protected from mechanical stress. Appropriate packaging of the device, such as the original packaging, can improve the vibration resistance during transport.

NOTICE

Hardware damage due to condensation

Unfavorable weather conditions during transport can cause damage to the device.

- Protect the device against moisture (condensation) during transport in cold weather or in case of extreme temperature fluctuations.
- Do not put the device into operation until it has slowly adjusted to the room temperature.
- Should condensation occur, wait for about 12 hours before switching the device on.

4.2 Control cabinet installation

NOTICE

Extreme environmental conditions

Extreme environmental conditions can cause damage to the device.

- Avoid extreme environmental conditions.
- Protect the device against dust, moisture and heat.

NOTICE

Lack of air circulation

Incorrect installation of the device prevents air circulation in the device and thus causes overheating and impaired functioning.

- Only install the device in the corresponding wall in the orientation shown.

NOTICE

Incorrect installation

Mounting the device in a way that deviates from the documentation can impair its functionality.

- Mount the device only in the orientations shown in the documents.

The device is designed for installation in a control cabinet for machine and system engineering. The environmental conditions specified for operation must be observed.

Dimensions

The dimensions of the device can be found in the download finder on the Beckhoff website: <https://www.beckhoff.com/en-en/support/download-finder/search-result/?c-1=27833209&search=cp62xx>

All dimensions are in mm.

Preparation of the control cabinet

The control cabinet must have the required installation cutout according to the device dimensions of the panel PC.

The wall thickness must be between 1 mm and 5 mm for installation. In the case of a device with a stainless steel front, the wall thickness must be between 1 mm and 3 mm. After installation, be sure to check the tightness between the panel PC and the wall.

Please also note the following for installation in a control cabinet:

- Ensure that there is 5 cm of free space above and below the device for air circulation.
- Position the panel PC such that reflections from light sources on the screen are avoided as far as possible.
- For the correct installation height, use the position of the screen for guidance. This should always be optimally visible to the user.
- Do not expose the panel PC to direct sunlight.

Installation in the control cabinet

Once you have made the required cutout in the control cabinet, you can install the device in the control cabinet. Clamping levers are provided at the rear side of the housing for mounting of the device. In the delivery state, the clamping levers are turned onto the device (see Fig. 16).

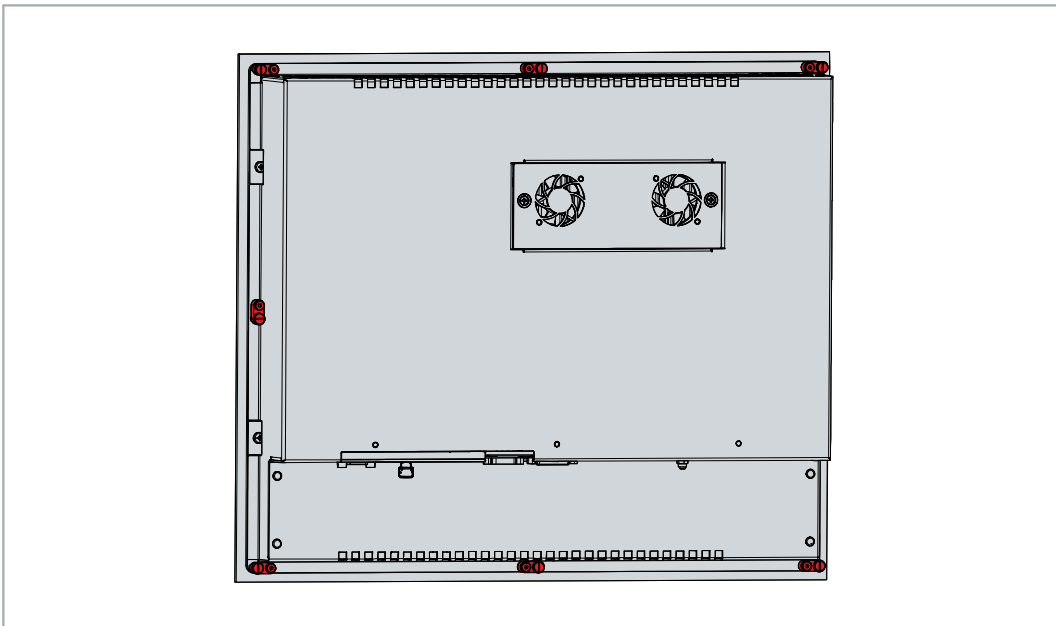

Fig. 21: Delivery state clamping lever

To install and secure the device in the control cabinet, follow the steps below:

1. Insert the device in the intended position in the control cabinet wall. Secure the device against falling out until it is fastened.

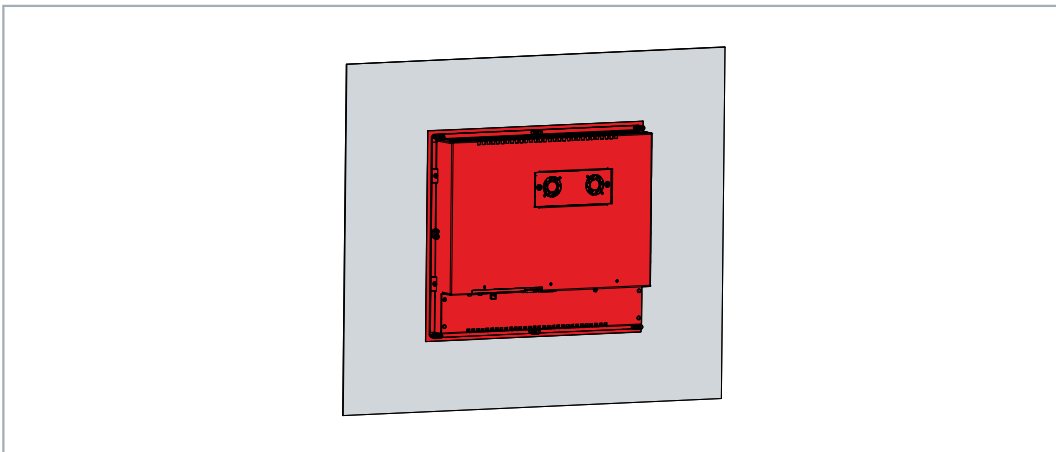

Fig. 22: Wall positioning

2. Turn the clamping levers 90° outwards (sections A and B).
3. Tighten the clamping levers with the Allen key 3.0 mm (section C).

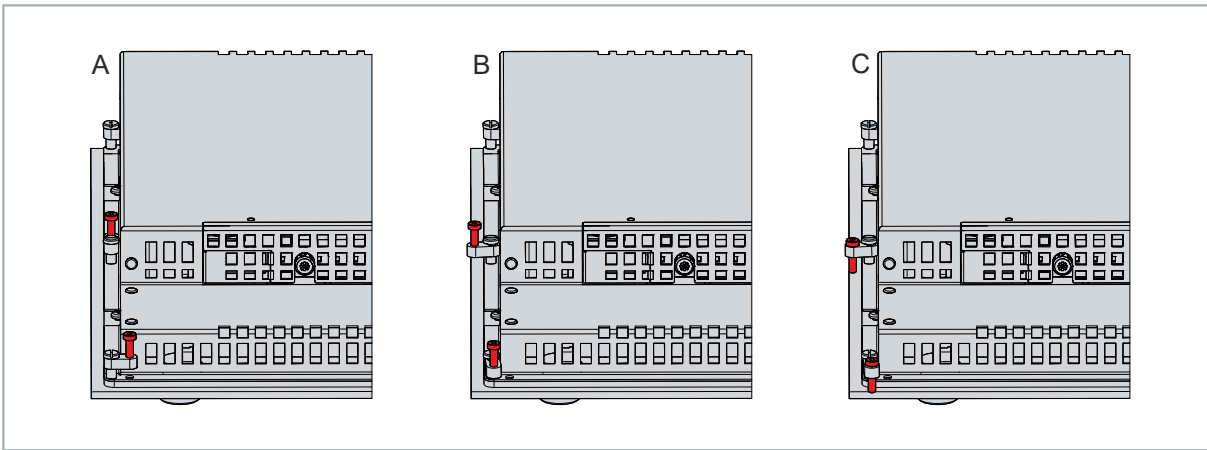

Fig. 23: Control cabinet installation

⇒ You have installed the device in the control cabinet.

4.3 Connecting the panel PC

⚠ CAUTION

Risk of electric shock

Dangerous touch voltages can lead to electric shock. To avoid electric shock, observe the following:

- Never connect or disconnect the device cables during a thunderstorm.
- Provide protective earthing for handling the device.

To make the device ready for operation, you have to connect it. The first step is to ground the device. Then you can connect the cables and the power supply.

An external 24 V DC power supply is required to operate the device. A nominal voltage of at least 22 V must be applied to the power supply plug of the device at all times.

The cabling of the panel PC in the control cabinet must be done in accordance with the standard EN 60204-1:2006 PELV = Protective Extra Low Voltage:

- The PE conductor (protective earth) and the "0 V" conductor of the voltage source must be on the same potential (connected in the control cabinet).
- Standard EN 60204-1:2006, section 6.4.1:b stipulates that one side of the circuit, or a point of the energy source for this circuit must be connected to the protective conductor system.

Peripheral devices connected to the device with their own power supply must have the same potential for the PE and "0 V" conductors as the control panel (no potential difference).

4.3.1 Mounting power supply cable

Install the cable for the power supply of the panel PC using the material supplied for connector assembly. It consists of an 8-pin connection strip and a strain relief housing with cable tie.

If you require a replacement for the voltage connector and the strain relief housing, you can order this from Beckhoff Sales under ordering option C9900-P926.

Mounting power supply cable

First mount the plug on the cable as follows:

1. Remove a few centimeters of the cable sheath.
 2. Remove the insulation from the wire ends (8-9 mm).
 3. Crimp the ferrules onto the stripped wire ends.
 4. Insert the cable ends with the ferrules into the 8-pin connection strip. For the pin assignment of the connector, see Chapter 3.2.5 [Power supply](#) [▶ 18].
 5. Screw the cable ends into the 8-pin connection strip.
- ⇒ You have mounted the plug on the cable.

Assembly of strain relief housing

Now mount the strain relief housing on the previously connected plug and power supply cable as follows:

1. Thread the cable tie into the lower part of the strain relief housing (section A).
2. Insert the connection strip into the lower part of the strain relief housing (section B).

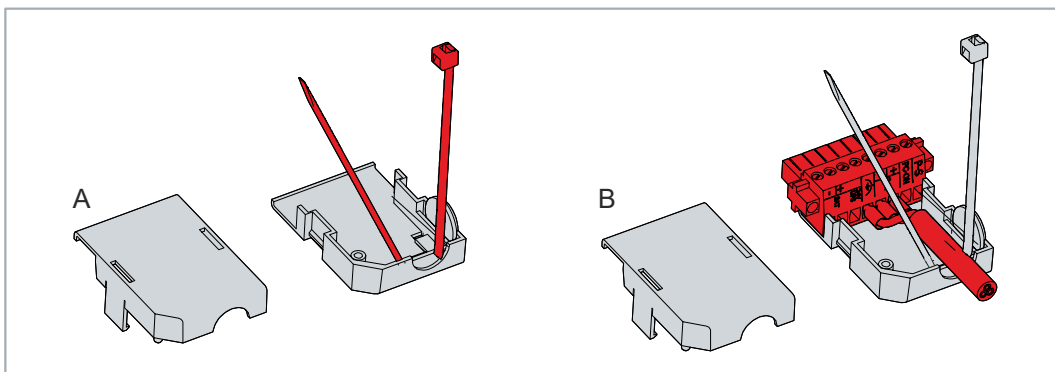

Fig. 24: Assembly of strain relief housing

3. Tighten the cable tie and remove the plastic tab (section C).
4. Attach the upper part of the strain relief housing by snapping it onto the lower part (section D).

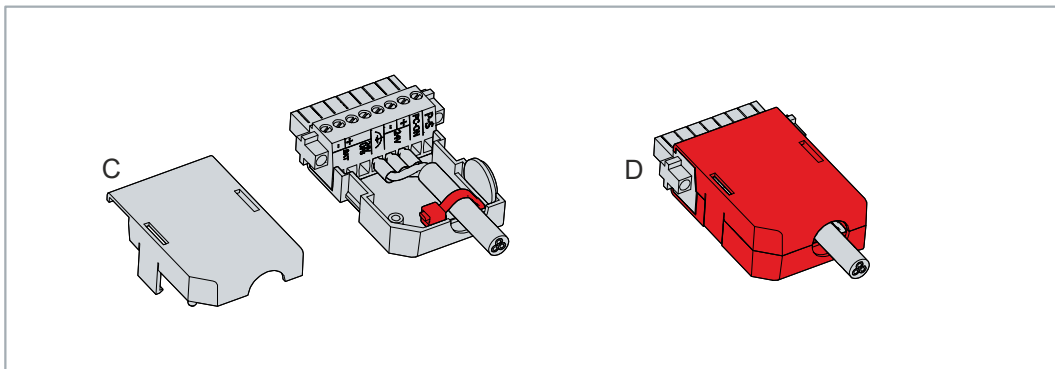

Fig. 25: Assembly of strain relief housing

- ⇒ You have mounted the strain relief housing.

To remove the strain relief housing, proceed as follows:

1. Use your fingers to bend the latching lugs on the lower part slightly outwards.

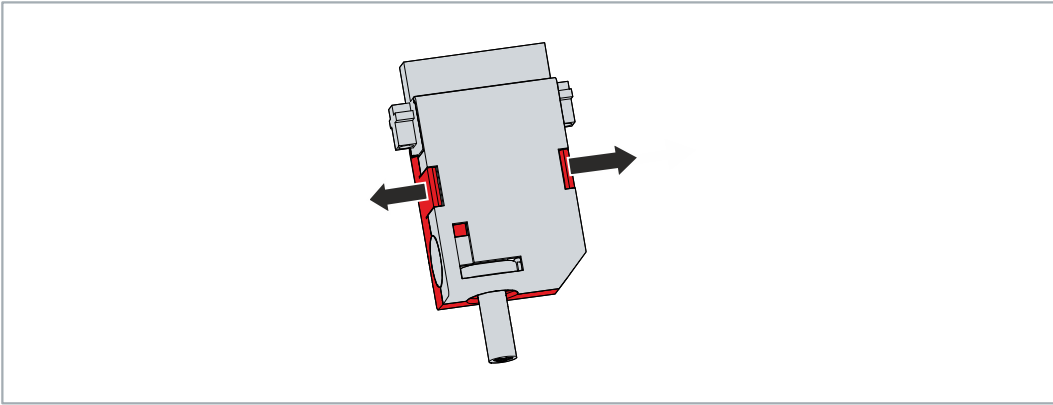

Fig. 26: Disassembly of the strain relief housing

2. Lever the upper part off the lower part.
 3. Cut the cable tie.
- ⇒ You have removed the strain relief housing.

4.3.2 Grounding the panel PC

Grounding or potential equalization of electronic devices minimizes potential differences and conducts electrical currents to ground. This is to prevent dangerous touch voltages and electromagnetic interference.

Protective earth

The protective grounding of a device serves to avoid dangerous touch voltages. According to the EN 60204-1 standard (Chapter 8 Potential equalization), protective grounding is required if:

- the device exceeds dimensions of 50 mm x 50 mm,
- the device can be touched or encompassed over a large area,
- contact between the device and active parts is possible,
- an insulation fault may occur.

Establish low-resistance protective earthing of the device via the voltage connection to avoid dangerous touch voltages. There is a pin in the voltage socket for the protective earth (PE).

EMC

NOTICE

Hardware damage due to electromagnetic interference

The use of the device without a functional earth can lead to material damage due to electromagnetic interference.

- Only use the device with functional earth.

Electromagnetic compatibility (EMC) of the device includes on the one hand not affecting other devices and equipment by electromagnetic interference and on the other hand not being disturbed by electrical or electromagnetic effects itself.

To do this, the device must comply with certain protection requirements. The device has EMC interference immunity according to EN 61000-6-2. The EMC interference emission of the device meets the requirements of EN 61000-6-4.

The functional earth is necessary for the EMC of the device. You establish functional earthing via the grounding connection between the grounding bolt in the connection section on the rear side of the device (see Fig. 22) and the central grounding point of the control cabinet in which the device is installed. Use wires with a cross-section of at least 10 mm² or a flat conductor for the ground connection, as the circumference of the conductor should be as large as possible.

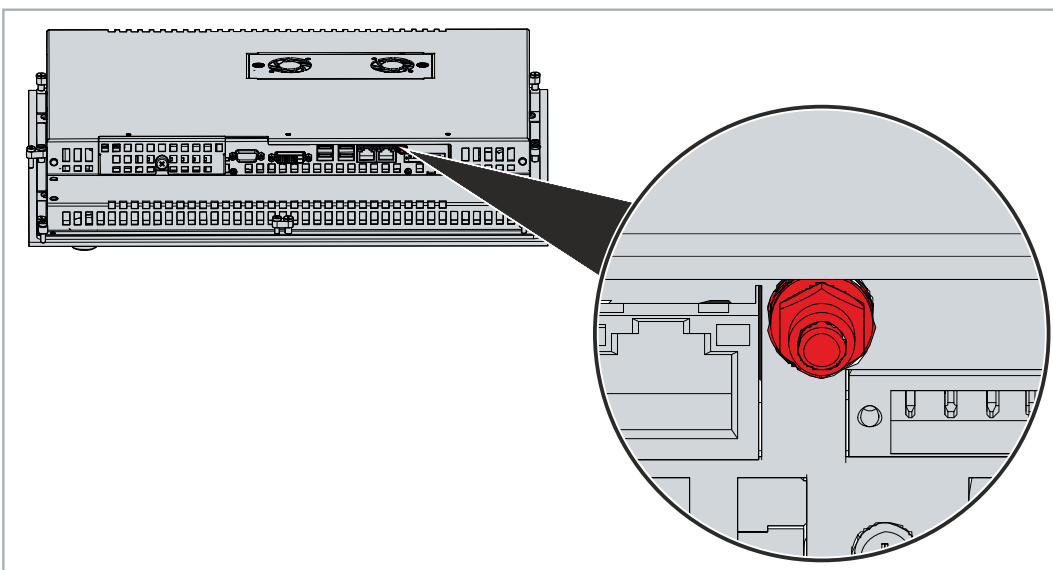

Fig. 27: Grounding bolt for functional earthing

4.3.3 Connecting cables and power supply

NOTICE
<p>Incorrect connection procedure</p> <p>Incorrect procedure when connecting the cables and the power supply can cause hardware damage.</p> <ul style="list-style-type: none"> • Follow the documented procedure for connecting the cables and the power supply. • Always connect the cables first and only then switch on the power supply. • Please read the documentation for the external devices prior to connecting them.

NOTICE
<p>Connection of incorrect battery packs</p> <p>Connecting the wrong battery packs can cause damage to the device and the battery packs.</p> <ul style="list-style-type: none"> • Only connect the C9900-U330 Beckhoff battery pack.

The connections are located at the rear of the device.

Connecting cables

Make sure that you ground the device first (see chapter 4.3.2 [Grounding the panel PC \[▶ 40\]](#)).

Connecting the power supply

Cables with a maximum cable cross-section of 1.5 mm² can be used for connecting the power supply. For long supply lines, use 1.5 mm² cables to achieve a low voltage drop on the supply line. There should be at least 22 V at the voltage connector of the device, so that the device remains switched on during voltage fluctuations.

Proceed as follows to connect the 24 V_{DC} power supply unit:

1. Plug the voltage connector into the voltage socket on the panel PC.
 2. Screw the voltage connector to the voltage socket.
 3. Connect the PC to your external 24 V power supply.
 4. Switch on the 24 V power supply.
- ⇒ You have connected the power supply.

External battery pack

If you ordered your device with an integrated UPS, then you can connect an external battery pack and install it on a DIN rail near to the PC. Use only the Beckhoff C9900-U330 battery pack:

Table 30: Order identifier battery pack

Order identifier	Link to option
C9900-U330	<p>https://www.beckhoff.com/cp62xx</p> <p>Select a product variant and then select the "Options" tab at the bottom of the website.</p>

You can use the UPS output of the power supply unit and connect a Beckhoff control panel as a second display. If the supply voltage fails and the panel PC is only supplied by the battery pack, the control panel remains in operation. Second display operators can use it to read the power failure notification, back up data, and shut down the operating system.

PIN 4 and 5 of the battery pack are available for looping through a 24 V power supply. Accordingly, you can connect a three-core sheathed cable with plus and minus of the supply voltage as well as protective earth to the battery pack and then connect to the PC with a five-core sheathed cable. The method of connecting different components can be taken from the wiring diagram in fig. 23.

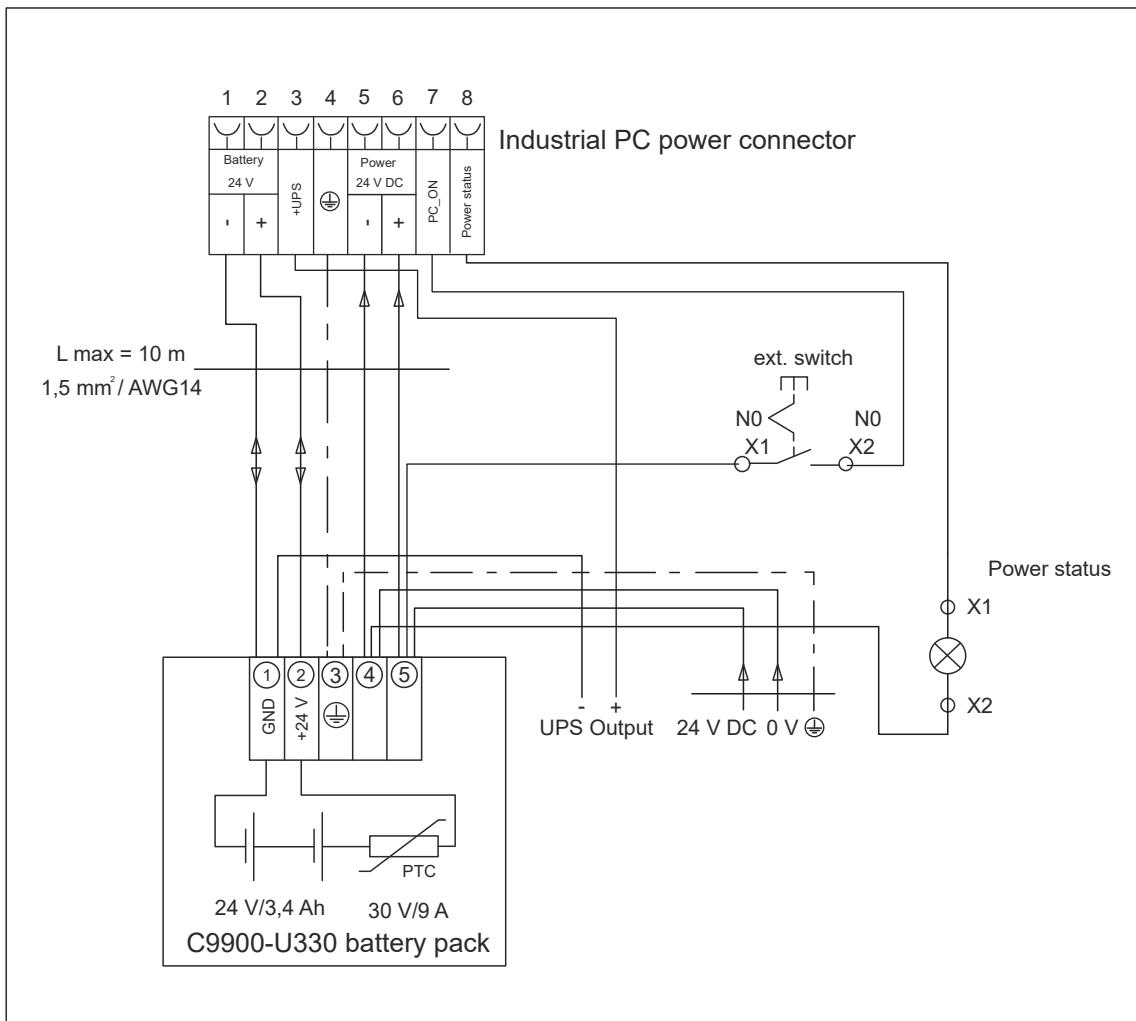

Fig. 28: Wiring diagram C9900-U330

Further information on the battery pack can be found in the corresponding manual in the download finder on the Beckhoff website [C9900-U330](#).

4.4 Switching the panel PC on and off

NOTICE

Public networks

Connecting the device to public networks without additional protective measures can compromise the safety of the device.

- Protect the device before connecting it to public networks.

NOTICE

Data loss due to switching off the device while the software is running

Switching off the device before the running software is terminated and the operating system is shut down can lead to data loss.

- Quit the running software and shut down the operating system before switching off the device.

NOTICE**Data loss due to switching off the power supply when the UPS battery is empty**

Switching off the power supply when the UPS battery is empty can lead to data loss, as the operating system cannot be shut down properly without battery power.

- Ensure that the UPS battery is charged in the event of a power failure.
- For UPS C9900-P209 and C9900-U209, charge the battery exclusively via the switched-on PC. Never connect a charger.

NOTICE**Shortened battery life due to switching off the power supply**

If the power supply is simply switched off, the operating system shuts down via the battery. With daily use, this significantly shortens the life of the battery.

- Avoid switching off the power supply before shutting down the operating system.
- Use the PC-ON input (see the following description) to shut down the operating system in a battery-friendly manner.

The industrial PC is started or switched off when the system is switched on or off or when the power supply to the PC is connected or disconnected.

You can use the PC-ON input of the PC to control the startup and shutdown of the operating system. The PC-ON signal is inverted, which is why the operating system boots up at 0 V at the input and shuts down at 24 V. During operation, 0 V must therefore be permanently applied to the input. If you want to shut down the operating system, you must apply 24 V to the PC-ON input. Once the operating system has shut down, the PC power supply unit sets the Power Status output from 24 V to 0 V. This indicates that the shutdown is complete. You can then switch off the power supply. If you remove the 24 V from the PC-ON input before you have switched off the power supply, the operating system restarts. Therefore, 24 V must be applied to the PC-ON input until you have switched off the power supply.

To shut down the operating system properly, you can install an additional ON/OFF switch next to the machine's main switch to turn the machine on and off. The main switch can thus remain switched on in principle and thus ensures that the PC is still supplied with power during the shutdown of the operating system. Via the Power Status output, you can switch, for example, a contactor that switches off the entire system. The load capacity of the Power Status output is limited to max. 0.5 A. No fuse protection is required.

Driver installation

When you switch on the device for the first time, the optionally pre-installed operating system will be started. For any additional hardware you have connected, you have to install the drivers yourself afterwards. In addition, the Beckhoff Device Manager starts automatically. The Device Manager is a software from Beckhoff that supports you in configuring the device.

If you have ordered the device without an operating system, you must install this and the driver software for the additional hardware you have connected and for the components inside the device. Please follow the instructions in the documentation for the operating system and the additional components.

UPS software components

The UPS software components with the corresponding drivers must be installed on the PC in order to operate the power supply unit as a UPS. The software components and drivers are already installed on delivery of the PC with operating system. If they are not, you have to install the installation package *Beckhoff UPS* yourself.

You can obtain the installation package from Beckhoff Service (service@beckhoff.com). You then use the installation package to install the UPS software components. The UPS software components come with a detailed help function. Call up the help files either directly from the configuration register by clicking the Help button or start the file under *Start > Programs > Beckhoff > UPS software components*.

5 Configuration

The configuration chapter gives you an insight into the Beckhoff Device Manager on the one hand and the UPS configuration on the other. The UPS configuration is relevant if you ordered your device with a UPS.

The Beckhoff Device Manager is a tool for detailed system diagnostics of hardware and software components. The procedure after the first start and after manually starting Beckhoff Device Manager is explained.

In the UPS configuration, assign the appropriate UPS to the device.

5.1 Beckhoff Device Manager

The Beckhoff Device Manager enables detailed system diagnostics with uniform secure access to the existing hardware and software components. System data is recorded, analyzed and evaluated during operation. The data helps to detect deviations at an early stage and prevent device downtimes.

The user interface screenshots shown in this chapter are examples only and do not represent the actual state of your device.

The Beckhoff Device Manager always starts automatically after the device has been booted. In addition, you have the option of manually starting the previously closed Device Manager at any time.

The device is supplied with predetermined access data by default:

- User name: Administrator
- Password: 1

You also have the option of using the Beckhoff Device Manager to remotely configure the device via a web browser. More detailed information is available in the Beckhoff Device Manager [manual](#).

First start of Beckhoff Device Manager

When your device is booted for the first time, the Beckhoff Device Manager also starts automatically for the first time. The Security Wizard opens. It informs you that you should reset the default password set by Beckhoff. Proceed as follows:

1. Click **Next** on the Security Wizard start page.
 - ⇒ This will take you to the **Change Passwords** page:

Fig. 29: Beckhoff Device Manager – Change passwords

2. Enter the access data of the Device Manager on delivery.
3. Choose a secure new password. Instructions for choosing a secure password are given below.
4. Confirm the changes by clicking on the tick in the red box on the right.
5. Exit the Security Wizard.

⇒ You have reached the Device Manager start page.

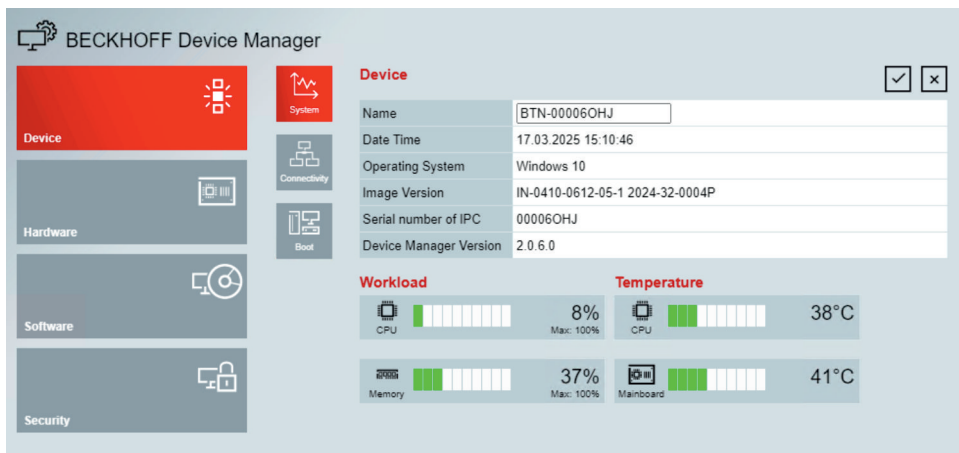

Fig. 30: Beckhoff Device Manager – Start page

Continue to navigate in the menu and to configure the device. Note that modifications only become active once they have been confirmed.

Manual start of Beckhoff Device Manager

To start the Beckhoff Device Manager manually, proceed as follows:

1. Open a web browser locally on the device.
2. Enter `localhost/config` in the web browser to start the Beckhoff Device Manager.

⇒ The Beckhoff Device Manager starts. The Security Wizard appears.

Secure passwords

Strong passwords are an important prerequisite for a secure system.

Beckhoff supplies the device images with standard user names and standard passwords for the operating system. It is imperative that you change these.

Controllers are shipped without a password in the UEFI/BIOS setup. Beckhoff recommends assigning a password here as well.

Please note the following:

- Passwords should be unique for each user and service.
- Only change passwords after an incident in which passwords have become known without authorization.
- Train the device users in the use of passwords.

A secure password has the following characteristics:

- Password complexity: The password should contain capital and lower-case letters, numbers, punctuation marks and special characters.
- Password length: The password should be at least 10 characters long.

5.2 UPS configuration

Once you have installed the installation package with the UPS software components, you can configure the UPS. To start the configuration, go to `Start -> Beckhoff -> UPS Configuration`.

After starting the configuration, follow the steps below:

1. Click *Select*.

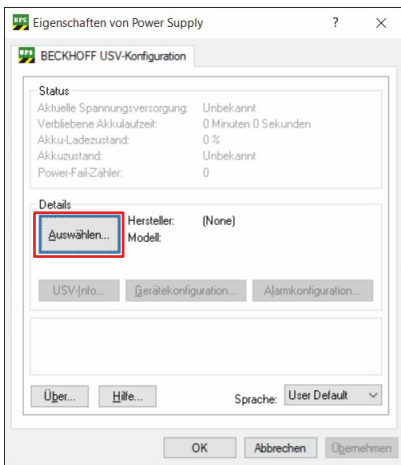

Fig. 31: Select UPS

2. Select the manufacturer *Beckhoff* from the drop-down menu.

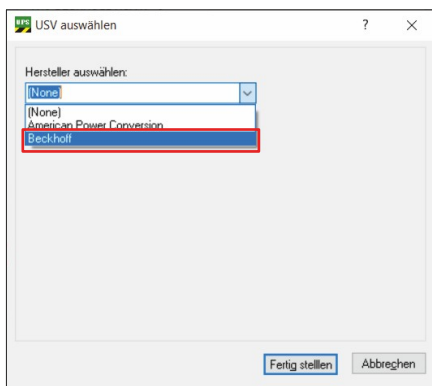

Fig. 32: Select manufacturer

3. Select at Model/Interface *Beckhoff P24Vxxxx*.
4. Select the port *COM4*.
5. Click *Finish*.

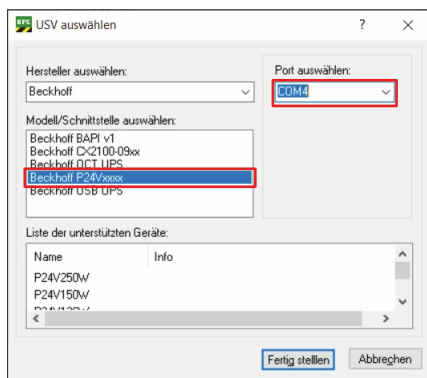

Fig. 33: Select model/interface & port

6. Click *Apply*.

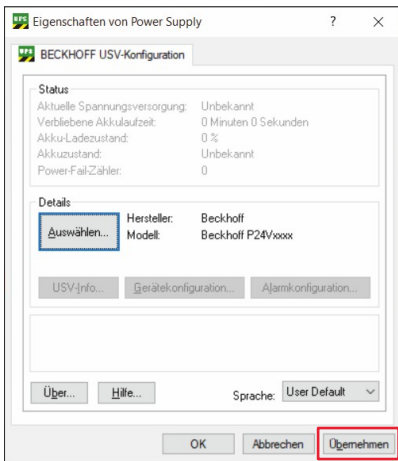

Fig. 34: Apply configuration

⇒ You have configured the UPS. The status of the connected UPS is displayed.

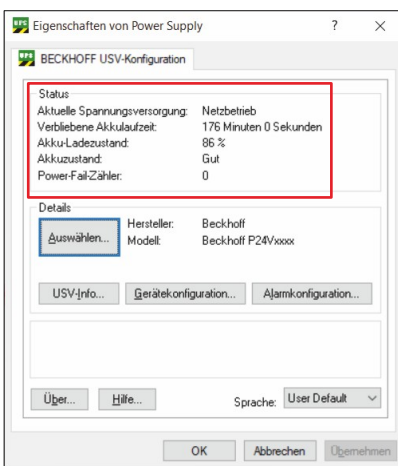

Fig. 35: UPS status

6 Decommissioning

NOTICE

Hardware damage due to power supply

A connected power supply can cause damage to the device during disassembly.

- Disconnect the power supply from the device before starting to disassemble it.

As part of the decommissioning of the device, you must first disconnect the power supply and cables. You can then remove the device from the control cabinet.

If you do not wish to use the device any further, chapter 6.2 Disassembly and disposal provides information on the correct disposal of the device.

6.1 Disconnecting the power supply and cables

⚠ CAUTION

Risk of electric shock

Dangerous touch voltages can lead to electric shock. To avoid electric shock, observe the following:

- Never connect or disconnect the device cables during a thunderstorm.
- Provide protective earthing for handling the device.

Before disassembling the device, you must disconnect the cables and the power supply. Follow the steps below:

1. Shut down the operating system.
 2. Disconnect the device from your external 24 V power supply.
 3. Pull the power plug out of the power supply socket.
 4. Make a note of the wiring of all data transmission cables if you want to restore the cabling with another device.
 5. Disconnect all data transmission cables from the device.
 6. Finally, disconnect the ground connection.
- ⇒ You have disconnected the cables and the power supply.

6.2 Disassembly and disposal

Before you can remove the device from the control cabinet, you must first disconnect the power supply and the cables (see chapter 6.1 [Disconnecting the power supply and cables](#) [▶ 48]).

To remove the device from the control cabinet, follow the steps below:

1. Loosen the clamping levers with a 3.0 mm Allen key (sections A and B). Secure the device against falling out of the control cabinet wall.
2. Rotate the clamping levers 90° back onto the device (section C) and retighten them to prevent unintentional release.

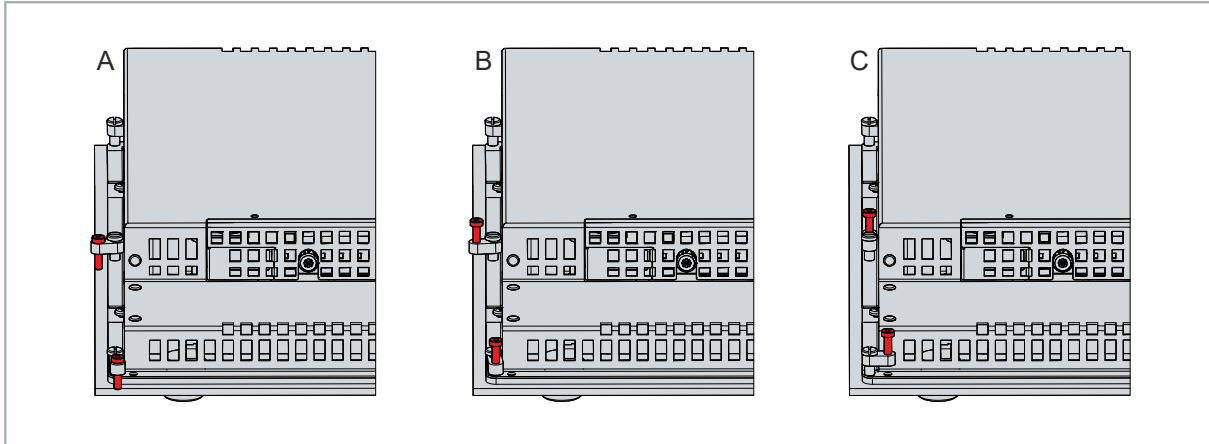

Fig. 36: Removal from the control cabinet

⇒ You can now remove the device from the corresponding cutout in the control cabinet wall.

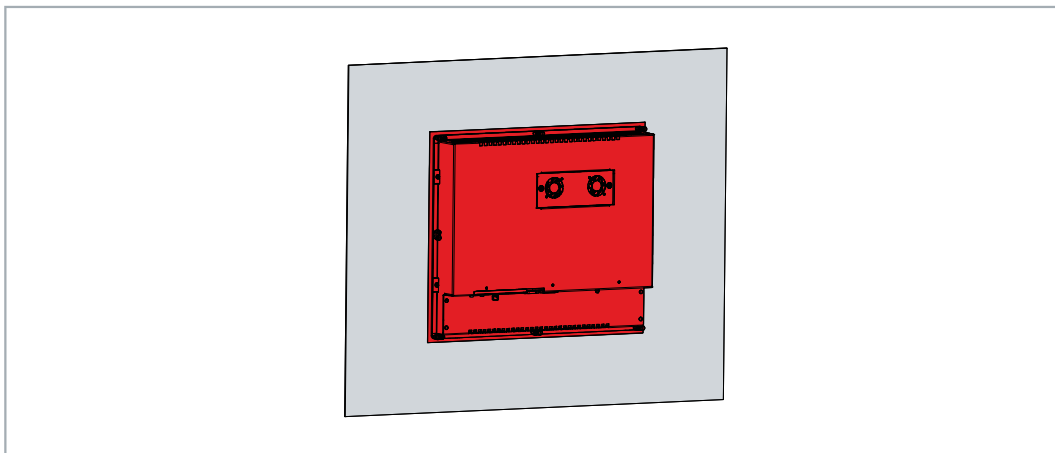

Fig. 37: Removal installation cutout

Disposal of the panel PC

When disposing of the device follow the national electronic scrap regulations. In order to dispose of the device, it must be removed and fully dismantled. Dispose of the components in the following way:

- Send plastic parts (polycarbonate, polyamide (PA6.6)) for plastics recycling.
- Take metal parts to the metal recycling collection point.
- Electronic parts such as fans and circuit boards must be disposed of in accordance with national electronic scrap regulations.
- Stick insulating tape over the poles of the CR2032 battery on the motherboard and dispose of the battery via the local battery recycling.

7 Maintenance

⚠ CAUTION

Risk of electric shock

Working on the device when live can lead to electric shock.

- Switch off the power supply before replacing device components. Excluded from this is the replacement of hard disks and 2½" SSDs in RAID configuration as well as fan cartridges.

Maintenance measures increase the efficiency of the device by ensuring long-term functionality. Cleaning and maintenance by replacing certain device components contribute to this.

7.1 Cleaning

NOTICE

Unsuitable cleaning agents

The use of unsuitable cleaning agents can damage the device.

- Clean the device only as specified.

It is essential to observe the following points when cleaning the device:

- Observe the general conditions of protection rating IP65 and IP20.
- Never use compressed air to clean the device.
- Maintain an ambient temperature range of 0 °C to 55 °C.

Cleaning agents

In order to avoid damage to the front of the panel PC during cleaning, you must use suitable cleaning agents. Examples include:

- benzine
- spirit
- glass cleaner

Avoid the following cleaning agents:

- detergents with scouring or abrasive components
- metal cleaning objects such as razor blades or steel spatulas
- steam jet cleaner or very hot water
- cold water with a heated device
- high water pressure, e.g. high-pressure cleaner

Cleaning the front screen

You can clean the front screen of the device during operation. In order to avoid inadvertent touch entries when doing this, you must first set the device to "Cleaning Mode" with the help of the Beckhoff Display Control Tool.

The Beckhoff Display Control Tool does not start automatically when the device starts up. Proceed as follows to activate the "Cleaning Mode" of the Beckhoff Control Tool:

1. Click the Beckhoff Display Control Tool icon to start it.
 - ⇒ When the tool is started, a small sun symbol appears in the taskbar.
2. Right-click the sun symbol.
3. Select the "Cleaning Mode" (see Fig.).

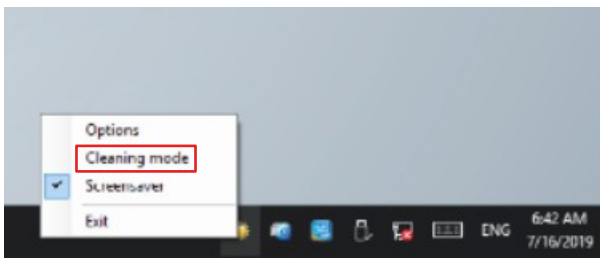

Fig. 38: Select "Cleaning Mode"

⇒ "Cleaning Mode" is activated. You can now clean the front panel.

You can set the duration for which the device should remain in "Cleaning Mode". The period can be set between 5 and 120 seconds. Right-click the sun symbol again and click "Options". Now select the appropriate duration (see Fig.).

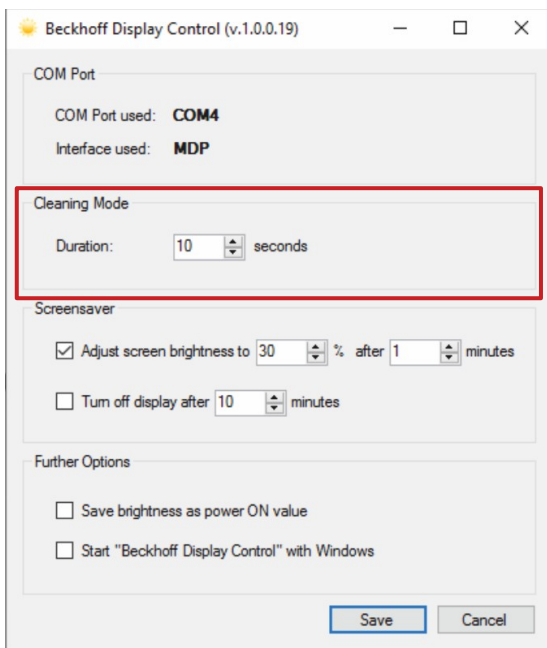

Fig. 39: Configuration "Cleaning Mode"

7.2 Maintenance

NOTICE

Use of incorrect spare parts

The use of spare parts not ordered from Beckhoff Service can lead to unsafe and faulty operation.

- Only use spare parts that you have ordered from Beckhoff Service.

Beckhoff devices are manufactured from components of the highest quality and robustness. They are selected and tested for best interoperability, long-term availability and reliable function under the specified environmental conditions.

Nevertheless, some components of the devices may be subject to a limited service life if they are operated under certain conditions, such as at increased ambient temperatures during operation or during storage or during long periods of storage out of operation.

Beckhoff therefore recommends replacing some of the components of the devices after the time after which predictions of the remaining service life of such components can no longer be reliably calculated.

The following table provides recommendations for the regular, precautionary replacement of the device components:

Table 31: Device component replacement recommendations

Component	Recommendation for replacement intervals (years)
UPS battery pack	5 years
2.5-inch hard disk	5 years or after 20,000 operating hours at more than 40 °C or after 30,000 operating hours at less than 40 °C
3.5-inch hard disk	5 years, irrespective of the operating hours
Fan	7 years
CFast, SSD, MicroSD, Compact Flash	10 years
Motherboard battery	5 years

Beckhoff is excluded from liability in the event of possible damage occurring during maintenance work. In order to avoid damage caused by electrostatic discharge when replacing device components, protective measures are recommended. Below are some suggestions.

ESD protection

NOTICE

Electrostatic discharge

The replacement of device components without ESD protection can lead to functional impairment and destruction of the device.

- If possible, apply ESD protection measures during maintenance work.

When working on electronic devices, there is a risk of damage due to ESD (electrostatic discharge), which can impair the function or destroy the device.

Protect the device and create an ESD-protected environment in which existing electrostatic charges are safely discharged to ground and charging is prevented.

An ESD-protected environment can best be created by setting up ESD protection zones. The following measures serve this purpose:

- ESD-compliant floors with sufficient conductivity to the reference potential PE;
- ESD-compatible work surfaces such as tables and shelves;
- Wrist grounding strap, especially for sedentary activities;
- grounded and electrostatically dissipating equipment and operating materials (e.g. tools) within the ESD protection zone.

If it is not possible to create an ESD protection zone, you can still protect the device against ESD damage. For example, the following measures can be used:

- Use conductive mats connected to the ground potential as underlays.
- Dissipate possible charges from your own body by touching grounded metal (e.g. control cabinet door).
- Wear a wrist grounding strap.
- Only remove new electronic components from the ESD packaging (tinted plastic bag) after putting on the wrist grounding strap.
- Do not walk around with electronic components in your hand if they are not in ESD packaging.

7.2.1 Replacing the battery

NOTICE

Incorrect battery type

Using any other battery may cause fire or explosion.

- Only replace the battery with battery type R/C (BBCV2), order number RC2032, nominal voltage 3 V.
- When replacing the battery, make sure that the polarity is correct.

NOTICE

Battery damage

Incorrect handling of the motherboard battery can damage it.

- Do not recharge the battery.
- Do not throw the battery on the fire.
- Do not open the battery.
- Protect the battery against direct sunlight and moisture.

NOTICE

Failure of the electronics due to mechanical damage

Scratches or damaged components on PCBs can cause the electronics to fail.

- Be very careful when replacing the battery and avoid mechanical damage to the electronics.

The device does not contain a lithium-ion battery. The motherboard battery is a CR2032 lithium-metal cell. It is used to supply power to the clock integrated on the motherboard. If the battery is depleted or missing, the date and time are displayed incorrectly.

Table 32: Technical data of the battery

Battery type	Electrical properties (at 20 °C)		Dimensions		
	Nominal voltage	Nominal capacity	Diameter	Height	Weight
CR2032	3.0 V	225 mAh	20.0 mm	3.20 mm	3.1 g

The battery is located on the back of the device next to the connection section behind a cover. To replace the battery, follow the steps below:

1. Loosen the knurled screw on the cover.
2. Remove the cover.

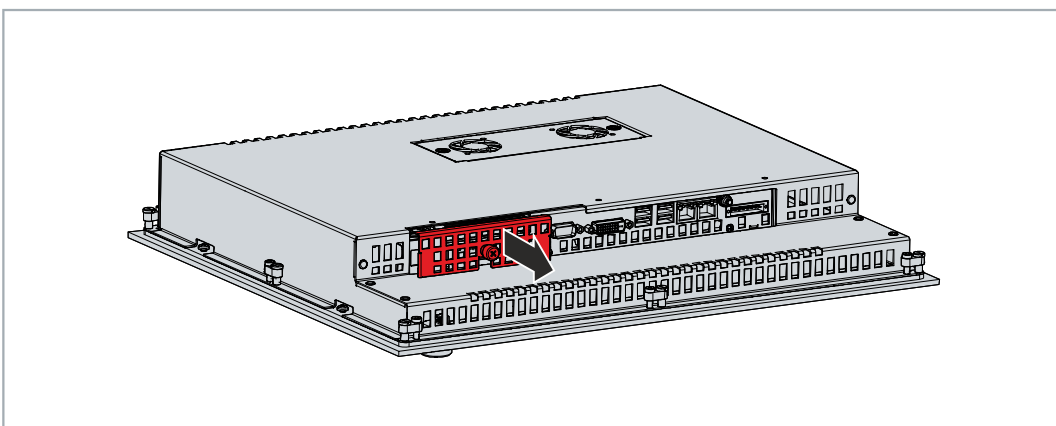

Fig. 40: Cover removal

3. Pull the battery out of the device.

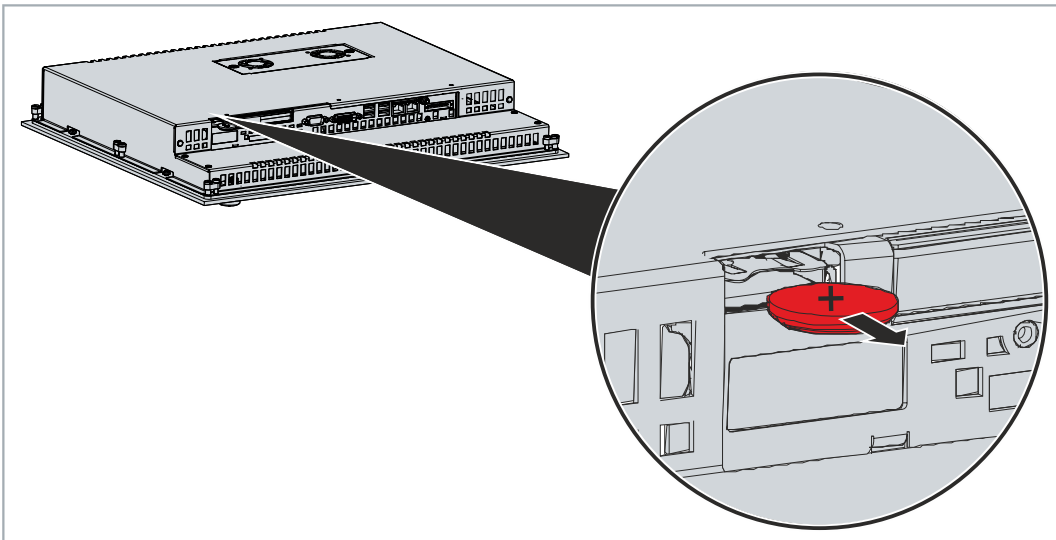

Fig. 41: Battery change

4. Insert the new battery into the device. Make sure that the positive pole is pointing backwards towards the rear panel.
 5. Put the cover back in place.
 6. Tighten the knurled screw firmly again.
- ⇒ You have successfully replaced the battery.

Battery disposal

To dispose of the battery, remove it, tape off the poles and put it in the battery disposal.

7.2.2 Replacing the storage media

Data transmission before replacement

If you want to exchange a storage medium according to Beckhoff's recommendation, you must copy the data from the old to the new storage medium. You can use the Beckhoff Service Tool (BST) for this purpose. BST is a graphical backup and restore program for devices with a Windows operating system. You can create an image of your operating system and use it to back up the operating system. Then you can restore the created image to a new data carrier. The BST is available on a bootable BST USB flash drive. This includes Windows and a backup tool. Select the size of the BST USB flash drive according to the size of the backup copy of your operating system. You can then keep the flash drive as a backup copy. For this purpose, the BST USB flash drives are designed for particularly long data preservation by means of special flash. For more information on the function of the BST, please refer to the corresponding [manual](#).

If your storage medium is defective and there is no backup, Beckhoff Service can provide you with a fresh Windows image. For this to be possible, your Beckhoff device must already have been delivered with a valid operating system license. After installing the fresh image, the applications must be reinstalled.

The storage media are located on the back of the device next to the connection section behind a cover. Regardless of which storage medium you want to exchange, you must first gain access to it. To do this, loosen the knurled screw and remove the cover.

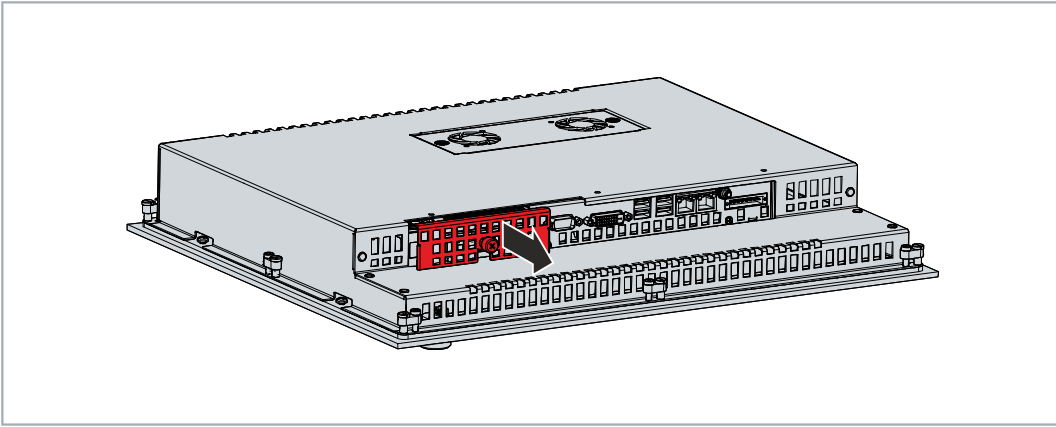

Fig. 42: Cover removal

Replacing the hard disk/SSD

There are height compensation strips on the hard disk/SSD to ensure safe operation in the event of vibrations and shocks. The height of the compensation strips differs according to the data carrier type. If you order replacement hard disks and SSDs directly from Beckhoff, please specify your device type or the serial number of your device. The height compensation strips then have the required height for your device. A sticker for pulling out the data carrier is also provided on Beckhoff data carriers.

To replace the hard disk or SSD, follow the steps below:

1. Pull the hard disk or SSD firmly out of the device using the protruding Beckhoff sticker.

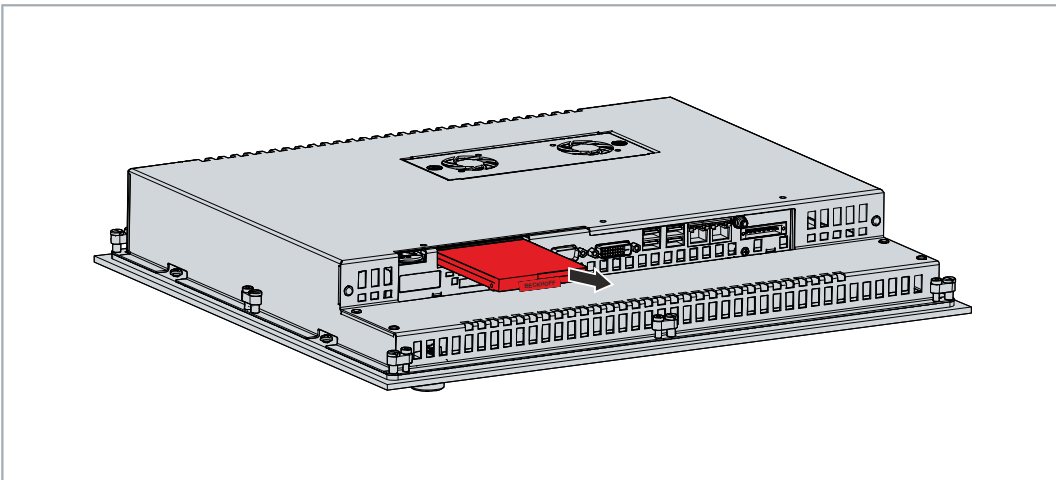

Fig. 43: Replacing the hard disk/SSD

2. Insert the new hard disk into the device in the same orientation up to the stop. The sticker on the hard disk/SSD must face the rear panel.
- ⇒ You have replaced the hard disk or SSD.

Replacing CFast

To replace the CFast, follow the steps below:

1. Press lightly against the CFast, as if pressing a button.
 - ⇒ When you release the CFast, the push-pull mechanism guides the CFast out of the slot far enough for you to grab it.
2. Pull the CFast out of the device.

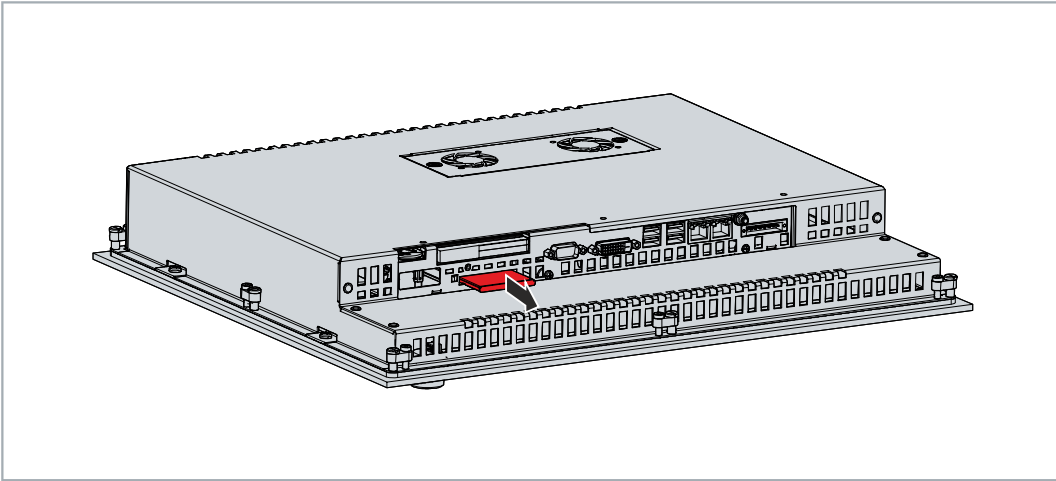

Fig. 44: Replacing CFast

3. Insert the new CFast into the device in the same orientation until it protrudes just a bit from the device. The sticker with the CFast designation must face the rear panel.
 4. Push the CFast into the device.
- ⇒ You have replaced the CFast.

If you have ordered a CP6201-xxxx-00x0 or a CP6211-xxxx-00x0, the CFast is located on the back of the device next to the fans. The replacement of the CFast remains basically unchanged as described above. However, you must first gain access to the CFast as follows:

1. Remove the two M4 screws.
2. Remove the cover of the CFast.

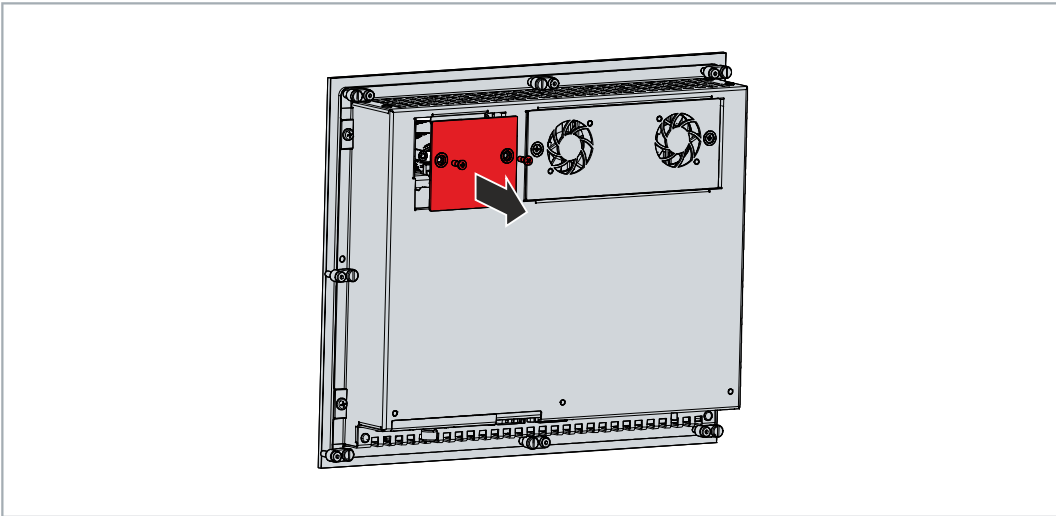

Fig. 45: Removing cover CFast

⇒ You now have access to the CFast.

Disposal of storage media

Delete confidential or technologically important data from the storage media before disposing of it. If a storage medium is defective, you must destroy it mechanically to prevent access to the data.

The old storage media must be disposed of in accordance with the national electronic waste regulations.

7.2.3 Replacing the fan

NOTICE

Incorrect fan type

The device may be damaged if the wrong type of fan is installed.

- Only replace the fans with replacement fans from Beckhoff Service.

The fans ensure optimal cooling of the device. Order replacement fans only from Beckhoff. Please get in touch with your Beckhoff sales contact.

The fan cartridge is located at the back of the device. To replace them, follow the steps below:

1. Loosen the two M4 screws (section A).
2. Remove the fan cartridge from the device (section B).

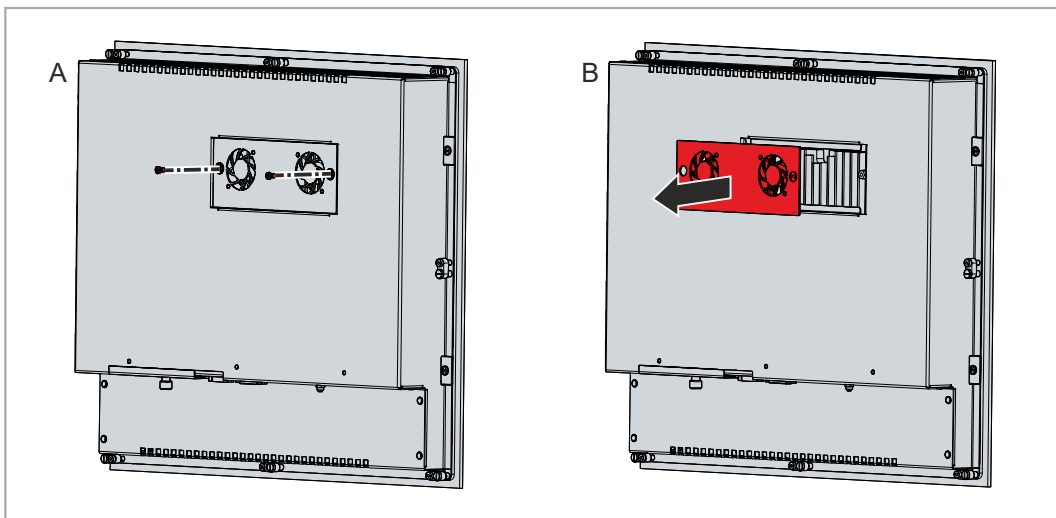

Fig. 46: Replacing the fan

3. Insert the new fan cartridge into the device.
⇒ You have now replaced the fan cartridge.

The old fan must be disposed of in accordance with the national electronic waste regulations.

8 Troubleshooting

Fault	Cause	Measures
No function of the panel PC	No power supply to the panel PC Other cause	Check the power supply cable Call Beckhoff Service
The Panel PC does not boot completely	BIOS setup settings are incorrect Other causes	Check BIOS setup settings (load defaults) Call Beckhoff Service
Panel PC boots, software starts, but controller does not work properly	The cause of the error is the software or plant parts outside of the panel PC	Call the machine and software manufacturer
The panel PC only works partially or only temporarily (e.g. dark screen image or none at all)	Defective backlight in the display Defective components in the panel PC	Call Beckhoff Service Call Beckhoff Service
USB error during access with TwinCAT via USB	Cycle times in TwinCAT set to 10 ms (default)	Increase the cycle times to between 50 ms and 80 ms

9 Technical data

Table 33: Technical data

Product designation	CP62xx-xxxx
Supply voltage	22-30 V DC, max. 5.5 A (24 V DC power supply)
Power consumption	Data sheet for power consumption and power loss in the download finder: https://www.beckhoff.com/en-en/support/download-finder/search-result/?download_group=691754572
Secure element	fTPM 2.0 enabled (see TPM manual)
Protection rating	Front IP65, rear IP20
Vibration resistance (sinusoidal vibration)	EN 60068-2-6: 10 to 58 Hz: 0.035 mm 58 to 500 Hz: 0.5 G (approx. 5 m/s ²)
Shock resistance (shock)	EN 60068-2-27: 5 G (approx. 50 m/s ²), duration: 30 ms
EMC interference immunity	conforms to EN 61000-6-2
EMC interference emission	conforms to EN 61000-6-4
Permissible ambient temperature	Operation: 0 °C ... +55 °C Transport / storage: -20 °C ... +65 °C
Permissible relative air humidity	Maximum 95%, no condensation
Transport and storage	The values for air humidity and shock resistance are to be observed during transport and storage and in operation. Suitable packaging of the panel PC can improve its shock resistance during transportation.

10 Appendix

In the appendix you will find information for servicing and details of the approvals that your device has.

10.1 Service and support

Beckhoff and its worldwide subsidiaries offer comprehensive service and support, providing fast and competent assistance for all issues relating to Beckhoff products and system solutions.

Beckhoff Service

The Beckhoff Service Center provides support in all forms of after-sales service:

- on-site service
- repair service
- spare parts service
- hotline service

Hotline: + 49 5246/963-460
email: service@beckhoff.com

If your device requires attention, please state its serial number, which you can find on the name plate.

Beckhoff Support

Support offers you comprehensive technical assistance to help you with the application of individual Beckhoff products, and also with other extensive services:

- world-wide support
- design, programming, and commissioning of complex automation systems
- extensive training program for Beckhoff system components

Hotline: + 49 5246/963-157
email: support@beckhoff.com

Headquarters

Beckhoff Automation GmbH & Co. KG
Hülshorstweg 20
33415 Verl
Germany

Phone: + 49 5246/963-0
email: info@beckhoff.de

The addresses of the worldwide Beckhoff branches and agencies can be found on our website at <http://www.beckhoff.com/>.

You can also find further documentation for Beckhoff components there.

10.2 Approvals

Your device has at least the following approvals:

- CE
- EAC
- UKCA
- FCC

You will find all other applicable approvals on the name plate of your device.

FCC approvals for the United States of America

FCC: Federal Communications Commission Radio Frequency Interference Statement

This device was tested and complies with the limits for a digital device of class A, according part 15 of the FCC regulations. These limits are designed to provide adequate protection against adverse interference, if the device is used in a commercial environment. This device generates, uses and may emit radio frequency energy and may cause adverse interference with radio communications, if it is not installed and used in accordance with the operating instructions. If this device is used in a residential area it is likely to cause adverse interference, in which case the user must take appropriate countermeasures in order to eliminate the interference at his own expense.

FCC approvals for Canada

FCC: Canadian Notice

This device does not exceed the class A limits for radiation, as specified by the Radio Interference Regulations of the Canadian Department of Communications.

List of figures

Fig. 1	Comparison of device extensions	10
Fig. 2	Structure.....	11
Fig. 3	Connection section.....	12
Fig. 4	RS232 interface pin numbering.....	13
Fig. 5	DVI interface pin numbering.....	14
Fig. 6	USB interface pin numbering	15
Fig. 7	Ethernet interface pin numbering	16
Fig. 8	Power supply pin numbering.....	18
Fig. 9	Installation of PCIe® modules.....	19
Fig. 10	Ethernet interface pin numbering	20
Fig. 11	RS232 interface pin numbering.....	21
Fig. 12	RS485 interface pin numbering.....	22
Fig. 13	RS422 interface pin numbering.....	23
Fig. 14	USB interface pin numbering	24
Fig. 15	RS232 interface pin numbering.....	25
Fig. 16	RS485 interface pin numbering.....	25
Fig. 17	RS422 interface pin numbering.....	26
Fig. 18	USB interface pin numbering	27
Fig. 19	Gigabit Ethernet PC network card pin numbering.....	28
Fig. 20	Name plate.....	29
Fig. 21	Delivery state clamping lever	36
Fig. 22	Wall positioning	36
Fig. 23	Control cabinet installation	37
Fig. 24	Assembly of strain relief housing	38
Fig. 25	Assembly of strain relief housing	38
Fig. 26	Disassembly of the strain relief housing.....	39
Fig. 27	Grounding bolt for functional earthing	40
Fig. 28	Wiring diagram C9900-U330.....	42
Fig. 29	Beckhoff Device Manager – Change passwords	44
Fig. 30	Beckhoff Device Manager – Start page	45
Fig. 31	Select UPS.....	46
Fig. 32	Select manufacturer	46
Fig. 33	Select model/interface & port.....	46
Fig. 34	Apply configuration.....	47
Fig. 35	UPS status	47
Fig. 36	Removal from the control cabinet	49
Fig. 37	Removal installation cutout	49
Fig. 38	Select "Cleaning Mode"	51
Fig. 39	Configuration "Cleaning Mode"	51
Fig. 40	Cover removal.....	54
Fig. 41	Battery change	55
Fig. 42	Cover removal.....	56
Fig. 43	Replacing the hard disk/SSD	56
Fig. 44	Replacing CFast.....	57

Fig. 45	Removing cover CFast.....	57
Fig. 46	Replacing the fan	58

List of tables

Table 1	Device extension options	9
Table 2	Legend structure	11
Table 3	RS232 interface pin numbering.....	13
Table 4	DVI interface pin assignment	14
Table 5	USB interface device generation.....	15
Table 6	USB interface pin assignment.....	15
Table 7	Controller classification based on device generation	16
Table 8	Ethernet interface pin assignment.....	16
Table 9	LED meaning: speed 100/1000 Mbit/s	17
Table 10	LED meaning: speed 100/1000/2500 Mbit/s	17
Table 11	Voltage socket pin assignment	18
Table 12	Options PCIe® modules.....	19
Table 13	Options Interfaces Connection section	19
Table 14	Ethernet interface pin assignment.....	20
Table 15	RS232 interface pin numbering.....	21
Table 16	RS485 pin assignment	22
Table 17	RS485 standard configuration.....	22
Table 18	RS422 pin assignment	23
Table 19	RS422 standard configuration.....	23
Table 20	USB interface pin assignment.....	24
Table 21	RS232 interface pin numbering.....	25
Table 22	RS485 pin assignment	25
Table 23	RS485 standard configuration.....	26
Table 24	RS422 pin assignment	26
Table 25	RS422 standard configuration.....	27
Table 26	USB interface pin assignment.....	27
Table 27	Ethernet interface pin assignment.....	28
Table 28	Legend name plate	29
Table 29	Key functions.....	31
Table 30	Order identifier battery pack.....	41
Table 31	Device component replacement recommendations	52
Table 32	Technical data of the battery.....	54
Table 33	Technical data.....	60

Trademark statements

Beckhoff®, TwinCAT®, TwinCAT/BSD®, TC/BSD®, EtherCAT®, EtherCAT G®, EtherCAT G10®, EtherCAT P®, Safety over EtherCAT®, TwinSAFE®, XFC®, XTS® and XPlanar® are registered trademarks of and licensed by Beckhoff Automation GmbH.

Third-party trademark statements

Intel, the Intel logo, Intel Core, Xeon, Intel Atom, Celeron and Pentium are trademarks of Intel Corporation or its subsidiaries.

Microsoft, Microsoft Azure, Microsoft Edge, PowerShell, Visual Studio, Windows and Xbox are trademarks of the Microsoft group of companies.

More Information:
www.beckhoff.com/cp62xx

Beckhoff Automation GmbH & Co. KG
Hülshorstweg 20
33415 Verl
Germany
Phone: +49 5246 9630
info@beckhoff.com
www.beckhoff.com

