

BECKHOFF New Automation Technology

Manual | EN

CP29xx-2xxx

Control Panel



Table of contents

1	Notes on the documentation	5
2	For your safety	6
2.1	Signal words	6
2.2	Intended use	6
2.3	Fundamental safety instructions	7
2.4	Operator's obligation to exercise diligence	7
2.5	Notes on information security	8
3	Product overview	9
3.1	Structure	10
3.2	Interface description	11
3.2.1	Power supply	11
3.2.2	USB	12
3.2.3	DVI	12
3.3	Name plate	13
3.4	Connection cables/connection kits	14
4	Commissioning	15
4.1	Transport and unpacking	16
4.2	Installation in the control cabinet	17
4.2.1	C6030 installation	20
4.2.2	Installation in the control cabinet	22
4.3	Connecting the control panel	24
4.3.1	Installing power supply cable	25
4.3.2	Grounding the control panel	27
4.3.3	Connecting cables and power supply	28
5	Shutting down	29
5.1	Disconnecting the power supply and cables	29
5.2	Disassembly and disposal	30
6	Servicing and maintenance	31
7	Troubleshooting	32
8	Technical Data	33
9	Appendix	34
9.1	Service and support	34
9.2	Approvals	35

1 Notes on the documentation

This description is intended exclusively for trained specialists in control and automation technology who are familiar with the applicable national standards.

It is absolutely necessary to comply with the documentation and the following notes and explanations when installing and commissioning the components.

The trained specialists must always use the current valid documentation.

The trained specialists must ensure that the application and use of the products described is in line with all safety requirements, including all relevant laws, regulations, guidelines, and standards.

Disclaimer

The documentation has been compiled with care. The products described are, however, constantly under development.

We reserve the right to revise and change the documentation at any time and without notice.

Claims to modify products that have already been supplied may not be made on the basis of the data, diagrams, and descriptions in this documentation.

Trademarks

Beckhoff®, TwinCAT®, TwinCAT/BSD®, TC/BSD®, EtherCAT®, EtherCAT G®, EtherCAT G10®, EtherCAT P®, Safety over EtherCAT®, TwinSAFE®, XFC®, XTS®, and XPlanar® are registered and licensed trademarks of Beckhoff Automation GmbH.

If third parties make use of the designations or trademarks contained in this publication for their own purposes, this could infringe upon the rights of the owners of the said designations.

Patents

The EtherCAT Technology is covered by the following patent applications and patents, without this constituting an exhaustive list:

EP1590927, EP1789857, EP1456722, EP2137893, DE102015105702

and similar applications and registrations in several other countries.



EtherCAT® is registered trademark and patented technology, licensed by Beckhoff Automation GmbH, Germany

Copyright

© Beckhoff Automation GmbH & Co. KG, Germany.

The distribution and reproduction of this document, as well as the use and communication of its contents without express authorization, are prohibited.

Offenders will be held liable for the payment of damages. All rights reserved in the event that a patent, utility model, or design are registered.

Third-party brands

Third-party trademarks and wordmarks are used in this documentation. The trademark endorsements can be found at: <https://www.beckhoff.com/trademarks>

2 For your safety

The signal words and their meanings are explained in the chapter on safety. They contain fundamental safety instructions that are essential for preventing personal injuries and damage to property.

Exclusion of liability

Beckhoff shall not be held liable in the event that this documentation is not complied with and the devices are therefore not used in line with the documented operating conditions.

2.1 Signal words

The signal words used in the documentation are classified below.

Warning on personal injuries

⚠ DANGER
High-risk hazard that will result in death or serious injury.
⚠ WARNING
Medium-risk hazard that may result in death or serious injury.
⚠ CAUTION
Low-risk hazard that may result in minor injury.

Warning on property and environmental damage

NOTICE
The environment, equipment, or data may be damaged.

2.2 Intended use

The control panel is designed for industrial application in machine and system engineering. It serves as the operating unit of the machine or plant.

The front of the device is designed for an IP65 working environment. It offers full protection against contact and against dust, as well as protection against water jets (nozzle) from any angle.

The rear side is designed for a working environment that meets the IP20 protection rating. It is protected against the penetration of fingers and solid foreign bodies of 12.5 mm in diameter or larger in size. It is not protected against water. Operation of the device in wet and dusty environments is not permitted.

The specified limits for technical data must be adhered to.

The device can be used within the documented operating conditions.

Improper use

Do not use the device outside the documented operating conditions.

2.3 Fundamental safety instructions

The following safety instructions must be observed when handling the device.

Application conditions

- Do not use the device under extreme environmental conditions.
- Only use the device in hazardous areas if it is explicitly designed for this purpose.
- Do not carry out any work on the device while it is live. Always switch off the supply voltage for the device before mounting it, replacing device components or rectifying malfunctions.
- Never plug or unplug connectors during thunderstorms. There is a risk of electric shock.
- Ensure that the device has a protective and functional earth connection.

Damage to property, loss of data and impairment of functions

- Ensure that only trained specialists with a control and automation engineering background, operate the device. Use by unauthorized persons can lead to damage to property and loss of data.
- In the case of a 24 V DC power supply unit, fuse the power supply line according to its cross-section to protect the supply line in the event of a short circuit.
- In case of fire, extinguish the device with powder or nitrogen.

2.4 Operator's obligation to exercise diligence

The operator must ensure that

- the products are used only for their intended purpose (see Chapter 2.2 [Intended use](#) [▶ 6]).
- the products are only operated in sound condition and in working order.
- the products are operated only by suitably qualified and authorized personnel.
- the personnel is instructed regularly about relevant occupational safety and environmental protection aspects, and is familiar with the operating instructions and in particular the safety instructions contained herein.
- the operating instructions are in good condition and complete, and always available for reference at the location where the products are used.

2.5 Notes on information security

The products of Beckhoff Automation GmbH & Co. KG (Beckhoff), insofar as they can be accessed online, are equipped with security functions that support the secure operation of plants, systems, machines and networks. Despite the security functions, the creation, implementation and constant updating of a holistic security concept for the operation are necessary to protect the respective plant, system, machine and networks against cyber threats. The products sold by Beckhoff are only part of the overall security concept. The customer is responsible for preventing unauthorized access by third parties to its equipment, systems, machines and networks. The latter should be connected to the corporate network or the Internet only if appropriate protective measures have been set up.

In addition, the recommendations from Beckhoff regarding appropriate protective measures should be observed. Further information regarding information security and industrial security can be found in our <https://www.beckhoff.com/secguide>.

Beckhoff products and solutions undergo continuous further development. This also applies to security functions. In light of this continuous further development, Beckhoff expressly recommends that the products are kept up to date at all times and that updates are installed for the products once they have been made available. Using outdated or unsupported product versions can increase the risk of cyber threats.

To stay informed about information security for Beckhoff products, subscribe to the RSS feed at <https://www.beckhoff.com/secinfo>.

3 Product overview

The Beckhoff Panel generation with industrially-compatible multi-touch display is designed for control cabinet installation. The devices offer suitable solutions for a variety of applications. The model variety ranges from different display sizes and formats to custom models. This Panel generation is also suited for single-touch applications.

The control panel has the following features:

- Different display sizes, landscape and portrait mode:
 - 15.6-inch (16:9)
 - 18.5-inch (16:9)
 - 19-inch (5:4)
 - 21.5-inch (16:9)
- Multi-finger touch screen (PCT): e.g. for 10-finger touch
- Aluminum housing with glass front, front IP65, rear IP20, the housing surface is electrically insulating
- Control cabinet installation via pull-out clamping levers for fast installation without loose parts

3.1 Structure

Figure 1 shows the device configuration as an example of all CP29xx-2xxx versions.



Fig. 1: Structure

Table 1: Legend structure

No.	Component	Description
1	Display and touch screen glass	Operating the control panel
2	Clamping lever	Mounting the control panel in the control cabinet
3	Industrial PC C6030, optional	Control system in machine and system engineering
4	Mounting plate for C6030	Part of the C6030: plate for mounting the industrial PC on the rear of the control panel
5	Fastening points for C9900-K790	Attaching the power supply cable adapter for shared use of CP29xx and C6030
6	Connection block	Access to the interfaces
7	Name plate	Information on the control panel equipment
8	Power supply (X101)	Connection of the power supply and external wiring of the control panel
9	Grounding bolt	Functional earth of the control panel
10	USB 3.0 interface (X104)	Connection of peripheral devices
11	DVI interface (X106)	Transmission of digital signals, connection to digital displays

3.2 Interface description

The control panel features the following interfaces, which are located at the back of the housing:

- Power supply
- USB 3.0
- DVI

3.2.1 Power supply

The control panel is supplied with a nominal input voltage of 24 V. The five-pin voltage socket (X101) is used for connection to the power supply and the external wiring of the control panel.

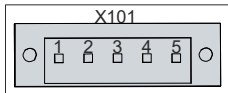

Fig. 2: Voltage connector pin numbering

Table 2: Voltage connector pin assignment

Pin	Signal	Description
1	NC	not used
2	NC	not used
3	⊕	Protective earth
4	-	Negative pole power supply 24 V
5	+ 24 V	24 V power supply, positive pole

The plug for the power supply is specified for 16 A and can accommodate wire cross-sections of up to 1.5 mm². For long supply lines, use 1.5 mm² cables to achieve a low voltage drop on the supply line. There should be at least 22 V at the power supply plug of the control panel, so that the control panel remains switched on during voltage fluctuations. The plug is included in the delivery. For information regarding replacement plugs and strain relief housing, refer to chapter 4.2.1 [Installing power supply cable](#) [► 25].

3.2.2 USB

The control panel has a USB 3.0 interface (X104) that supports the USB 3.0 specification. The control panel is connected to the industrial PC via the USB input.

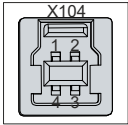

Fig. 3: USB interface pin numbering

Table 3: USB interface pin assignment

Pin	Connection
1	Vbus
2	D -
3	D +
4	GND
5	StdA_SSRX -
6	StdA_SSRX +
7	GND_DRAIN
8	StdA_SSTX -
9	StdA_SSTX +

3.2.3 DVI

The control panel has a DVI interface (X106). It is used to transmit the video signal from the industrial PC to the control panel.

The graphics signal is transmitted directly over a maximum distance of 5 m. The industrial PC requires a conventional DVI output. The resolution at the control panel depends on the distance from the display device.

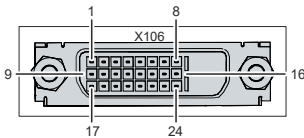

Fig. 4: DVI interface pin numbering

Table 4: DVI interface pin numbering

Pin	Signal	Pin	Signal	Pin	Signal
1	Rx2-	9	Rx1-	17	Rx0-
2	Rx2+	10	Rx1+	18	Rx0+
3	GND	11	GND	19	GND
4	Rx4-	12	Rx3-	20	Rx5-
5	Rx4+	13	Rx3+	21	Rx5+
6	DDC CLK	14	+ 5V DVI	22	GND
7	DDC DAT	15	GND	23	RxC+
8	AV SYNC	16	HPD	24	RxC-

3.3 Name plate

The name plate provides you with information on the equipment of the control panel. The name plate shown here is only an example.

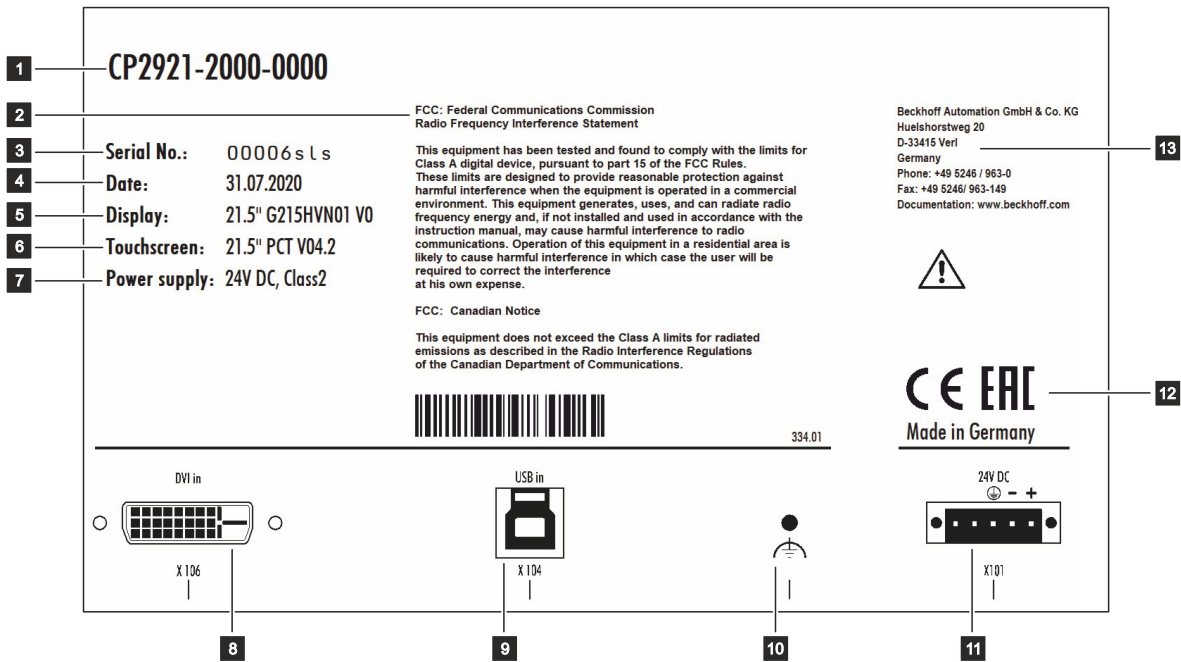

Fig. 5: Name plate example

Table 5: Legend name plate

No.	Description
1	Model: the last four digits indicate the device generation.
2	FCC approval
3	Serial number (BTN)
4	Date of manufacture
5	Display
6	Touch screen
7	Power supply: 24 V _{DC} , NEC class 2
8	DVI interface (X106)
9	USB interface (X104)
10	Grounding bolt
11	Connection of the power supply and external wiring of the control panel (X101)
12	Conformity symbols
13	Address of the vendor

3.4 Connection cables/connection kits

The following connection cables and ready-made connection kits are available for the CP29xx-2xxx:

Table 6: Connection cables/kits CP29xx

Connection cables/connection kits	Description
C9900-K774	Connection kit 1 m, includes: 1 m DisplayPort to DVI cable, 1 m USB cable
C9900-K775	Connection kit 3 m, includes: 3 m DisplayPort to DVI cable, 3 m USB cable
C9900-K776	Connection kit 5 m, includes: 5 m DisplayPort to DVI cable, 5 m USB cable
C9900-K780	DisplayPort connection cable for DVI-D display cable 1 m
C9900-K781	DisplayPort connection cable for DVI-D display cable 3 m
C9900-K782	DisplayPort connection cable for DVI-D display cable 5 m
C9900-K554	Connection cable USB-2.0 A-B, 1 m
C9900-K552	Connection cable USB-2.0 A-B, 3 m
C9900-K553	Connection cable USB-2.0 A-B, 5 m

Ready-made connection kits for DVI/USB connection are available as an option. They are included as standard when you order the C6030 as an option for mounting at the back of the control panel. They can also be ordered separately from Beckhoff sales, quoting the following article descriptions:

Table 7: Connection kits CP29xx with C6030

Connection kit	DVI/USB connection
C9900-K783	DisplayPort connection cable for DVI-D display cable 0.33 m
C9900-K784	Connection cable USB-2.0 A-B, 0.37 m
C9900-K790	Power supply cable adapter for shared use of C6030-2xxx-00x0 and CP29xx-2xxx-000

4 Commissioning

To use the control panel, you must first put it into operation. The first step is to transport the device to its operating location and unpack it. This is followed by installing the device in the control cabinet, connecting the cables and the power supply and finally switching on the control panel. Since the control panel does not have its own power switch, switching the power supply on and off also switches the control panel on and off.

Operating the device

The device is operated via the touch screen.

NOTICE

Damage to the touch screen

Operating the touch screen with unsuitable objects may damage the touch screen.

- Operate the touch screen only with bare fingers or wearing suitable gloves.
- If you use gloves, make sure that no hard particles such as metal shavings, glass splinters or similar adhere to the glove.

If you, as the user, require additional protection for the touch screen against dirt and scratching, for example due to dirty hands, this can be achieved with a protective film. The film provides short-term protection for a few days.

You can either order a protective film individually and fit it yourself retrospectively, or you can order the film for fitting directly ex factory. The protective films available for the display size of your device can be found on the Beckhoff website.

Proceed as follows to attach the protective film to the touch screen:

1. Ensure that the environment is as dust-free as possible.
 2. Thoroughly clean the surface of the device to be fitted with the film and remove all grease residues.
 3. Detach the film from the backing at the short edge and place it on the surface.
 4. Gradually remove the film from the backing. At the same time, use a doctor blade or other object with a soft rubber or felt edge to apply the film.
 5. Brush away air bubbles towards the edge with a doctor blade or other object with a soft rubber or felt edge.
- ⇒ The film is now fitted.

You can use the Dimming, Screensaver and Cleaning mode functions with the Display Control Tool. The Beckhoff Information System provides more information about the tool: <https://infosys.beckhoff.com/content/1031/panelconfigurationtools/11725543179.html?id=7993182328699786200>.

4.1 Transport and unpacking

The specified storage conditions must be observed (see chapter 8 [Technical Data](#) [► 33]).

Despite the robust design of the unit, the components are sensitive to strong vibrations and impacts. During transport the device must therefore be protected from mechanical stress. Appropriate packaging of the device, such as the original packaging, can improve the vibration resistance during transport.

NOTICE

Hardware damage due to condensation

Unfavorable weather conditions during transport can cause damage to the device.

- Protect the device against moisture (condensation) during transport in cold weather or in case of extreme temperature fluctuations.
- Do not put the device into operation until it has slowly adjusted to the room temperature.
- Should condensation occur, wait for about 12 hours before switching the device on.

Unpacking

Proceed as follows to unpack the unit:

1. Check the packaging for transport damage.
2. Remove packaging.
3. Keep the packaging for possible future transport.
4. Check your delivery for completeness by comparing it with your order.
5. Check the contents for visible shipping damage.
6. In case of discrepancies between the package contents and the order, or in case of transport damage, please inform Beckhoff Service (see Chapter 9.1 Service and support).

4.2 Installation in the control cabinet

NOTICE

Extreme environmental conditions

Extreme environmental conditions can cause damage to the device.

- Avoid extreme environmental conditions.
- Protect the device against dust, moisture and heat.

NOTICE

Lack of air circulation

Incorrect installation of the device prevents air circulation in the device and thus causes overheating and impaired functioning.

- Only install the device in the corresponding wall in the orientation shown.

NOTICE

Incorrect installation

Mounting the device in a way that deviates from the documentation can impair its functionality.

- Mount the device only in the orientations shown in the documents.

The device is designed for installation in a control cabinet for machine and system engineering. The environmental conditions specified for operation must be observed.

The dimensions of the control panel are required for the preparation of the control cabinet.

If you want to mount a C6030-200x-0060 on the rear of the control panel, you can find the corresponding dimensions in the C6030 device documentation.

All dimensions are in mm.

Fig. 6 shows the dimensions of the control panel with 15.6-inch display.

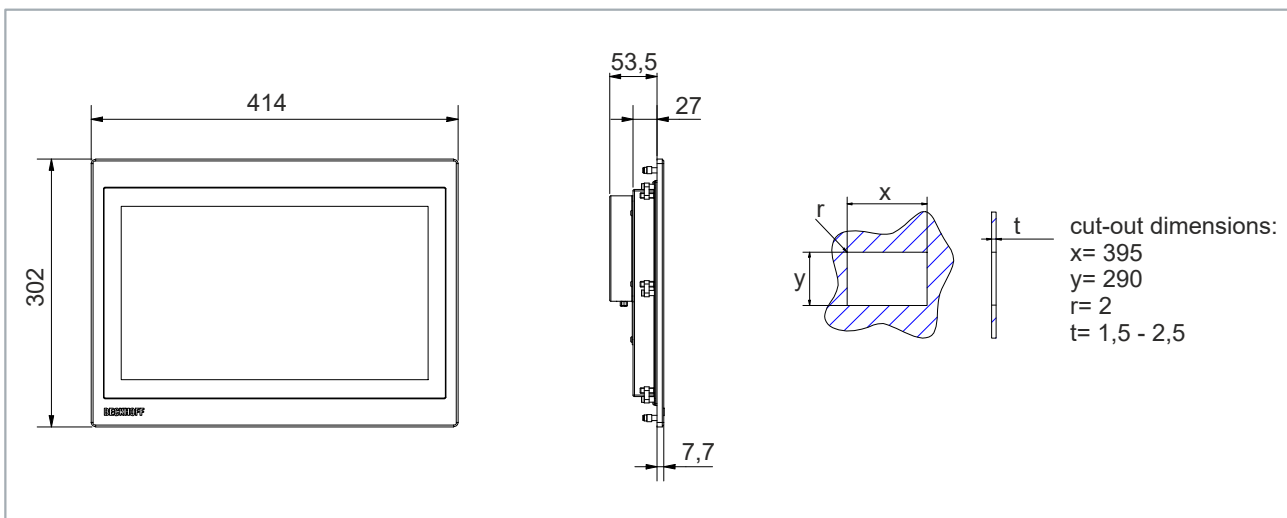

Fig. 6: Dimensions 15.6-inch

Fig. 7 shows the dimensions of the control panel with 18.5-inch display.

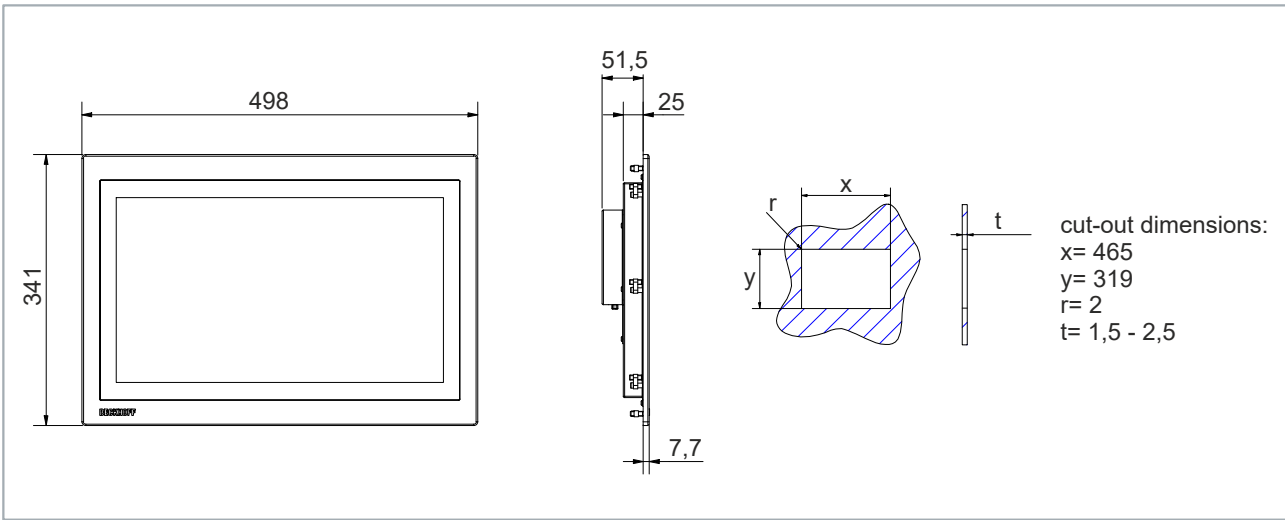

Fig. 7: Dimensions 18.5-inch

Fig. 8 shows the dimensions of the control panel with 19-inch display.

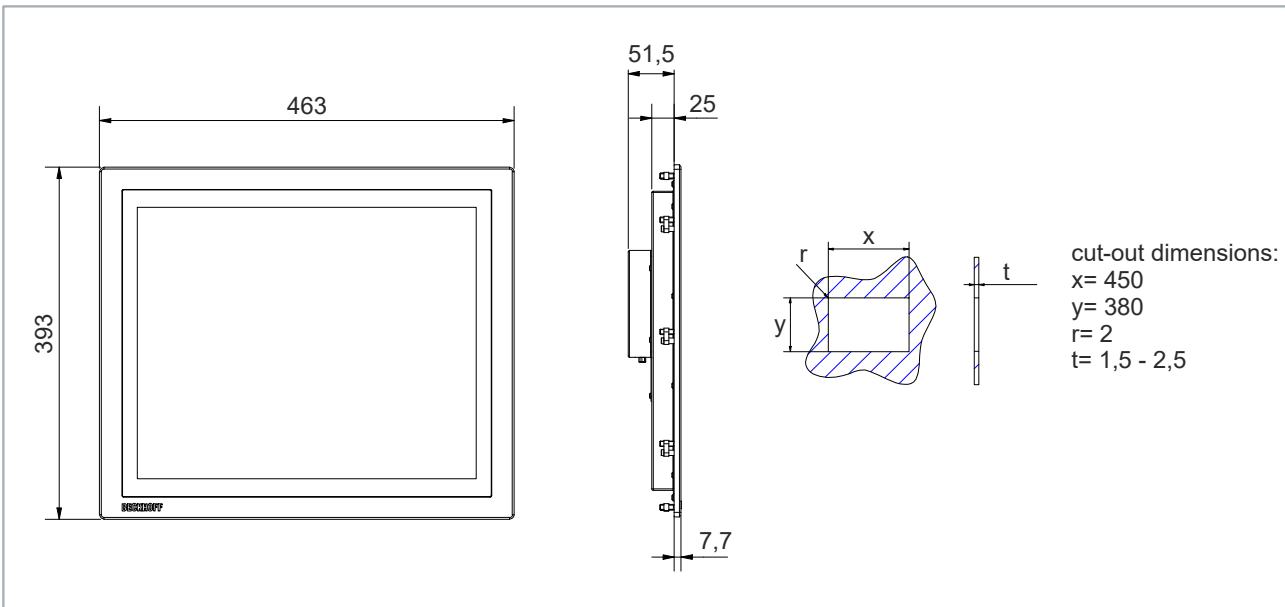

Fig. 8: Dimensions 19-inch

Fig. 9 shows the dimensions of the control panel with 21.5-inch display.

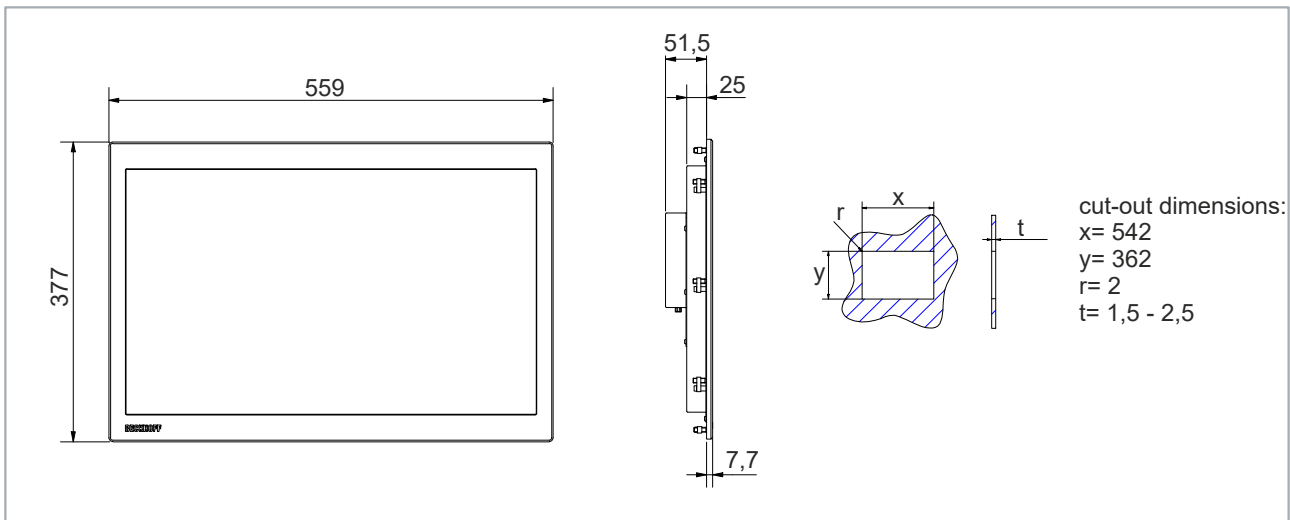

Fig. 9: Dimensions 21.5-inch

The C6030 Industrial PC can optionally be mounted at the back of the control panel. If you choose this option, you must first install the C6030 before you can mount the control panel in the control cabinet. You will find the corresponding information in the following chapters.

Also see about this

 [Technical Data \[▶ 33\]](#)

4.2.1 C6030 installation

A C6030 can optionally be mounted on the rear of the control panel. The following section contains the information required for installing the industrial PC.

The following two ordering options are available for the C6030 Industrial PC:

- C6030-2000-0060 (Smart Performance Class)
- C6030-2001-0060 (High Performance Class)

The housing of the control panel comes prepared with the mounting holes for the C6030. These are located on the rear of the device (see locations marked in Fig. 10).

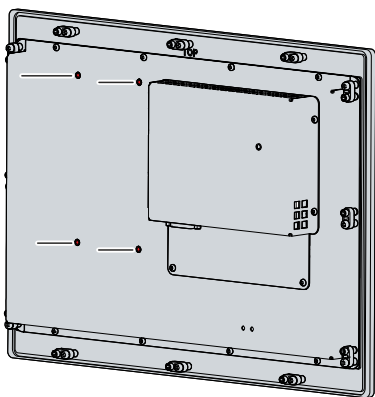

Fig. 10: Without C6030

The holes are drilled in such a way that you can mount the C6030 on the panel using the mounting plate over the side panel of the PC. Align the C6030 so that the fixing screws can be fitted at the marked points on the mounting plate (see Fig. 11).

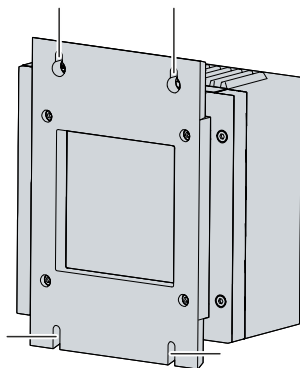

Fig. 11: Positions of the fastening screws

Place the C6030 over the holes on the panel and tighten the fastening screws (see Fig. 12).

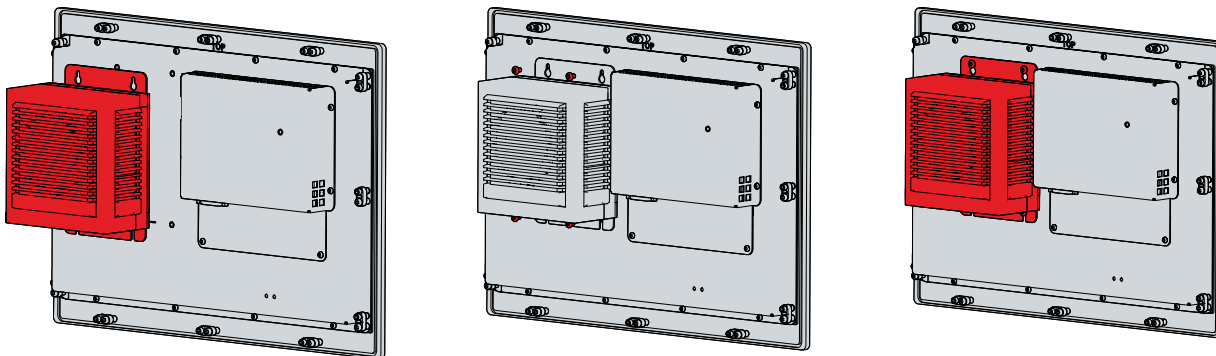

Fig. 12: C6030 installation

For more information about the C6030 Industrial PC please refer to the device documentation.

4.2.2 Installation in the control cabinet

Preparation of the control cabinet

The control cabinet must have the required installation cutout according to the device dimensions of the control panel. The wall thickness must be between 1 mm and 5 mm for installation. After installation, be sure to check the tightness between the control panel and the installation wall.

Please also note the following for installation in a control cabinet:

- Ensure that there is 5 cm of free space above and below the control panel for air circulation.
- Position the control panel such that reflections from light sources on the screen are avoided as far as possible.
- For the correct installation height, use the position of the screen for guidance. This should always be optimally visible to the user.
- Do not expose the control panel to direct sunlight.

Installation in the control cabinet

Once you have made the required cutout in the control cabinet, you can install the control panel in the control cabinet. Clamping levers are provided at the rear side of the housing for mounting of the device. In the delivery state, the clamping levers are folded onto the device (see Fig. 13).

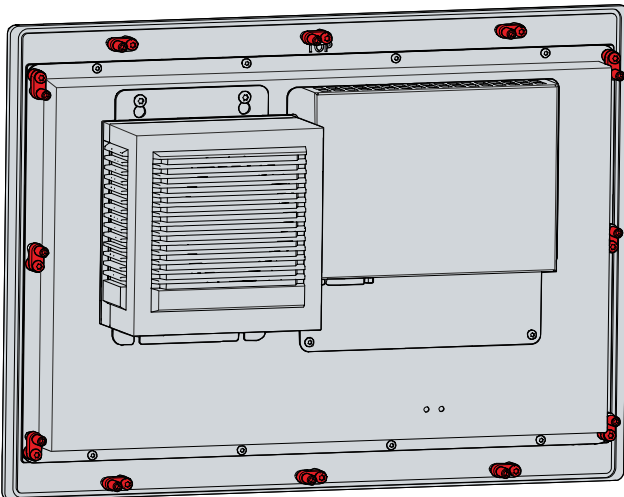

Fig. 13: Delivery state clamping lever

To install and secure the control panel in the control cabinet, follow the steps shown in Fig. 14 & 15:

1. Insert the control panel at the intended position in the control cabinet wall. Make sure that the device is secured against falling out until it is fastened properly.

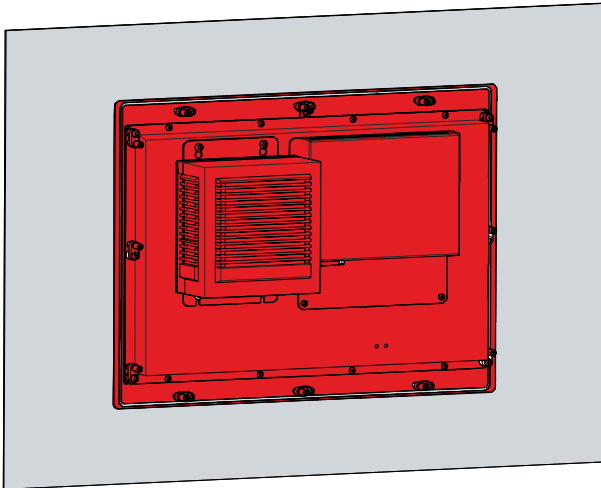

Fig. 14: Wall positioning

2. Turn the clamping levers 90° outwards (sections A and B).
 3. Tighten the clamping levers with the Allen key 3.0 mm (section C).
- ⇒ You have mounted the control panel in the control cabinet.

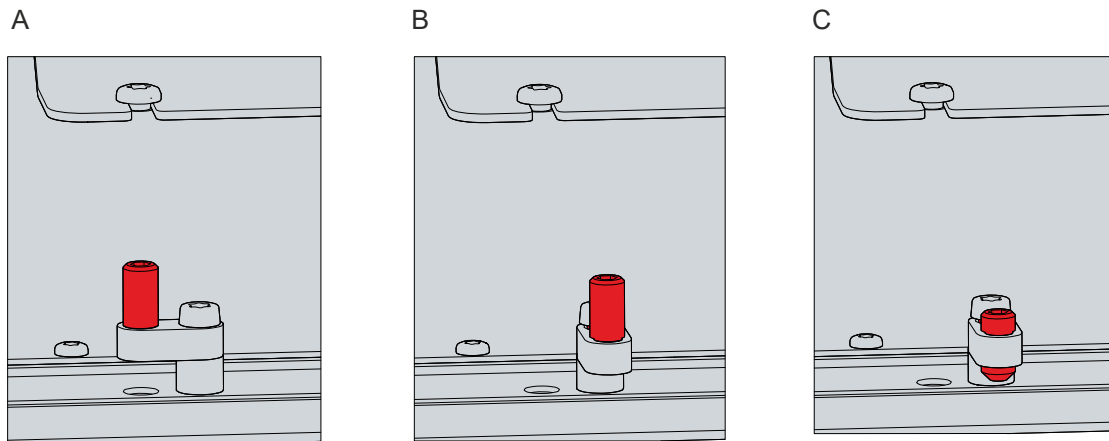

Fig. 15: Control cabinet installation

4.3 Connecting the control panel

⚠ CAUTION

Risk of electric shock

Dangerous touch voltages can lead to electric shock. To avoid electric shock, observe the following:

- Never connect or disconnect the device cables during a thunderstorm.
- Provide protective earthing for handling the device.

To make the device ready for operation, you have to connect it. The first step is to ground the device. Then you can connect the cables and the power supply.

An external power supply providing 24 V DC from an isolated source is required. This must be protected by a fuse in accordance with UL 248 with a maximum nominal value of 4 A. A nominal voltage of at least 22 V must be applied to the power supply plug of the device at all times.

The cabling of the device in the control cabinet must be done in accordance with the standard EN 60204-1:2006 PELV = Protective Extra Low Voltage:

- The PE conductor (protective earth) and the "0 V" conductor of the voltage source must be on the same potential (connected in the control cabinet).
- Standard EN 60204-1:2006, section 6.4.1:b stipulates that one side of the circuit, or a point of the energy source for this circuit must be connected to the protective conductor system.

Peripheral devices connected to the device with their own power supply must have the same potential for the PE and "0 V" conductors (no potential difference).

4.3.1 Installing power supply cable

Install the cable for the power supply of the control panel using the material supplied for connector assembly. It consists of a 5-pin connection strip and a strain relief housing with cable tie.

If you require a replacement for the voltage connector or the strain relief housing, you can order these from Beckhoff Sales using the following ordering option:

- C9900-P927: power supply connector for CP29xx multi-touch built-in Control Panel, 5-pin connector with strain relief for the external supply cable

Mounting power supply cable

First mount the plug on the cable as follows:

1. Remove a few centimeters of the cable sheath.
 2. Remove the insulation from the cable ends (8-9 mm).
 3. Crimp the ferrules onto the stripped wire ends.
 4. Insert the cable ends with the ferrules into the 5-pin connection strip. For the pin assignment of the connector, see Chapter Power supply.
 5. Screw the cable ends into the 5-pin connection strip.
- ⇒ You have fitted the plug to the power supply cable.

Assembly of strain relief housing

Now mount the strain relief housing on the previously connected plug and power supply cable as shown in Fig. 16:

1. Thread the cable tie into the lower part of the strain relief housing (section A).
 2. Insert the connection strip into the lower part of the strain relief housing (section B).
 3. Tighten the cable tie and remove the plastic tab (section C).
 4. Attach the upper part of the strain relief housing by snapping it onto the lower part (section D).
- ⇒ You have mounted the strain relief housing.

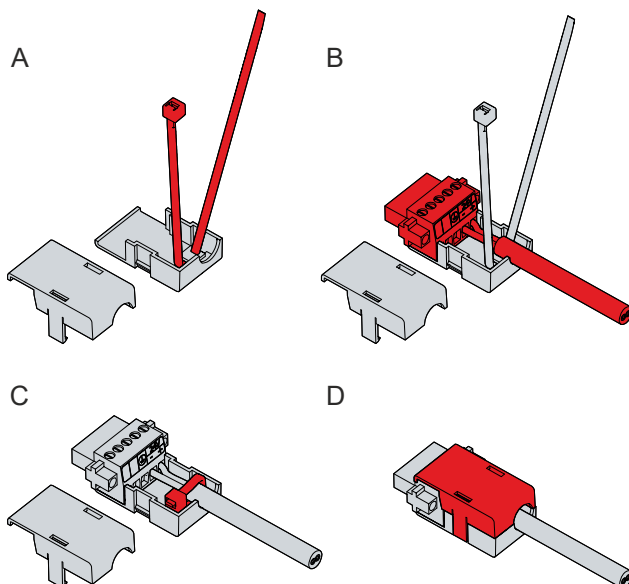

Fig. 16: Assembly of strain relief housing

To remove the strain relief housing, proceed as follows:

1. Use your fingers to bend the latching lugs on the lower part slightly outward (see Fig. 17).
2. Lever the upper part off the lower part.
3. Cut the cable tie.

⇒ You have removed the strain relief housing.

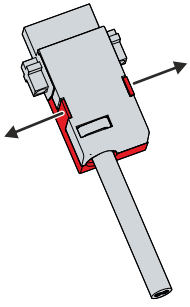

Fig. 17: Disassembly of the strain relief housing

4.3.2 Grounding the control panel

Potential differences are minimized and electrical currents are diverted to the ground through grounding or potential equalization of electronic devices. This is to prevent dangerous touch voltages and electromagnetic interference.

Protective earth

The protective grounding of a device serves to avoid dangerous touch voltages. According to the EN 60204-1 standard (Chapter 8 Potential equalization), protective grounding is required if:

- the device exceeds dimensions of 50 mm x 50 mm,
- the device can be touched or encompassed over a large area,
- contact between the device and active parts is possible,
- an insulation fault may occur.

Establish low-resistance protective earth of the control panel via the voltage connection to avoid dangerous touch voltages. There is a pin in the voltage socket for the protective earth (PE).

EMC

NOTICE

Hardware damage due to electromagnetic interference

The use of the device without a functional earth can lead to material damage due to electromagnetic interference.

- Only use the device with functional earth.

Electromagnetic compatibility (EMC) of the device includes on the one hand not affecting other devices and equipment by electromagnetic interference and on the other hand not being disturbed by electrical or electromagnetic effects itself.

To do this, the device must comply with certain protection requirements. The device has EMC interference immunity according to EN 61000-6-2. The EMC interference emission of the device meets the requirements of EN 61000-6-4.

The functional earth is necessary for the EMC of the device. You establish functional earthing via the grounding connection between the grounding bolt in the connection block on the rear side of the device (see Fig. 18) and the central grounding point of the control cabinet in which the Control panel is installed. Use wires with a cross-section of at least 4 mm² or a flat conductor for the ground connection, as the circumference of the conductor should be as large as possible.

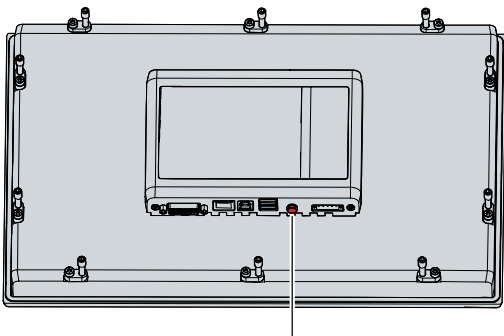

Fig. 18: Grounding bolt for functional earthing

4.3.3 Connecting cables and power supply

NOTICE

Incorrect connection procedure

Incorrect procedure when connecting the cables and the power supply can cause hardware damage.

- Follow the documented procedure for connecting the cables and the power supply.
- Always connect the cables first and only then switch on the power supply.
- Please read the documentation for the external devices prior to connecting them.

The connections are located at the rear of the control panel.

Connecting cables

Make sure that you first ground the panel (see chapter 4.3.2 [Grounding the control panel](#) [▶ 27]) and then plug in all data transmission cables.

When connecting the control panel to an industrial PC with UPS output, we recommend using this for the connection. In the case of CP-Link 4, we recommend connecting the CU880x transmitter boxes to the UPS output of the PC.

Connecting the power supply

Cables with a maximum cable cross-section of 1.5 mm² can be used for connecting the power supply. For long supply lines, use 1.5 mm² cables to achieve a low voltage drop on the supply line. There should be at least 22 V at the power supply plug of the control panel, so that the panel remains switched on during voltage fluctuations.

Proceed as follows to connect the 24 V_{DC} power supply unit:

1. First mount the power supply cable with the 5-pin connection strip without its strain relief housing.
2. Plug the voltage connector into the voltage socket on the panel.
3. Screw the voltage connector to the voltage socket.
4. Connect the panel to your external 24 V power supply.
5. Switch on the 24 V power supply.
6. Measure the voltage at the 5-pin connection strip of the panel.
7. Mount the strain relief housing on the 5-pin connection strip.

Also see about this

📖 Structure [▶ 10]

5 Shutting down

NOTICE

Hardware damage due to power supply

A connected power supply can cause damage to the device during disassembly.

- Disconnect the power supply from the device before starting to disassemble it.

When taking the control panel out of operation, you must first disconnect the power supply and cables. You can then remove the device from the control cabinet.

If you do not want to continue using the control panel, Chapter 5.2 [Disassembly and disposal](#) [► 30] provides information on the correct disposal of the device.

5.1 Disconnecting the power supply and cables

⚠ CAUTION

Risk of electric shock

Dangerous touch voltages can lead to electric shock. To avoid electric shock, observe the following:

- Never connect or disconnect the device cables during a thunderstorm.
- Provide protective earthing for handling the device.

NOTICE

Hardware damage due to power supply

Disconnecting the CP-Link 4 connection while the transmitter box power supply is switched on may cause damage to the transmitter box.

- Switch off the power supply to the CU8803 transmitter box before disconnecting the CP-Link 4 connection.

Before disassembling the control panel, you must disconnect the cables and the power supply. Follow the steps below:

1. Shut down the control panel.
 2. Disconnect the control panel from the external 24 V power supply.
 3. Pull the voltage connector out of the push-pull built-in power socket.
 4. Disassemble the power cable (see chap. 4.3.1 [Installing power supply cable](#) [► 25]) if the connector is to remain with the panel.
 5. Make a note of the wiring of all data transmission cables if you want to restore the cabling with another device.
 6. Disconnect all data transmission cables from the control panel.
 7. Finally, disconnect the ground connection.
- ⇒ You have disconnected the cables and power supply.

Also see about this

- 📖 [Installing power supply cable](#) [► 25]

5.2 Disassembly and disposal

Before you can remove the control panel from the control cabinet, you must first disconnect the power supply and the cables (see chapter 5.1 [Disconnecting the power supply and cables](#) [► 29]).

To remove the control panel from the control cabinet, follow the steps shown in Fig. 19:

1. Loosen the clamping levers with a 3.0 mm Allen key (sections A and B). Make sure that the device is secured against falling out until it is removed from the wall.
2. Fold the clamping levers back onto the housing by 90° (section C) and tighten them there again so that they do not fold out unintentionally.

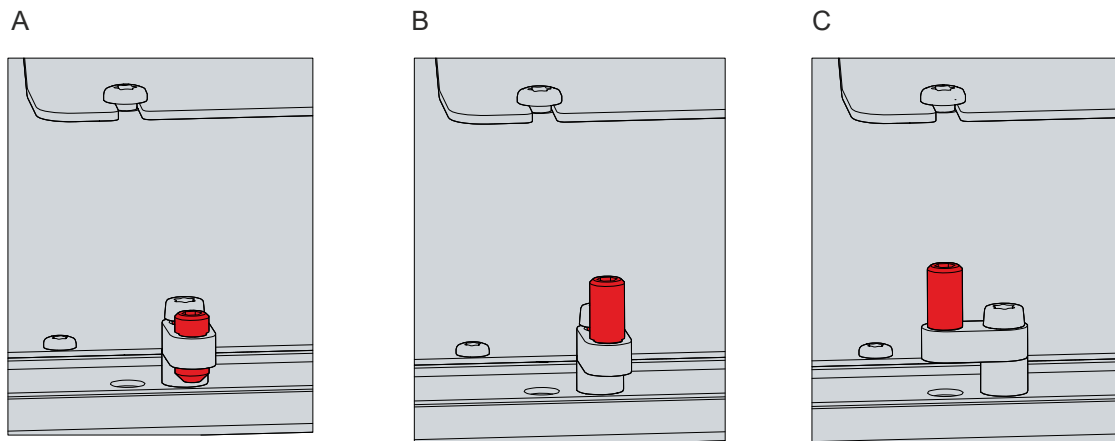

Fig. 19: Removal from the control cabinet

⇒ You can now remove the panel from the corresponding cutout in the control cabinet wall.

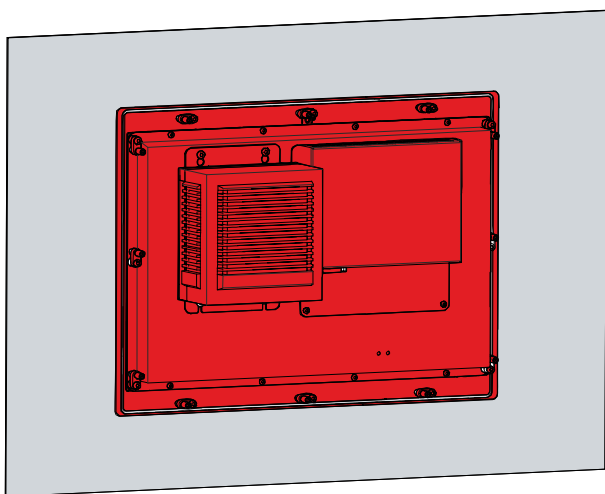

Fig. 20: Removal installation cutout

Disposal of the control panel

When disposing of the control panel the national electronic waste regulations must be followed.

For disposal, you must remove the device from the control cabinet.

6 Servicing and maintenance

Maintenance measures increase the efficiency of the device by ensuring long-term functionality. Cleaning the device contributes to this.

Defective pixels in the TFT display are production-related and are not grounds for complaint.

Cleaning

NOTICE

Unsuitable cleaning agents

The use of unsuitable cleaning agents can damage the device.

- Clean the device only as specified.

It is essential to observe the following aspects when cleaning the control panel:

- Keep to the boundary conditions of protection rating IP65/IP20.
- Never use compressed air to clean the control panel.
- Maintain an ambient temperature range of 0 °C to 55 °C.

Cleaning agents

In order to avoid damage to the front of the panel PC during cleaning, you must use suitable cleaning agents. Examples include:

- benzine
- spirit
- glass cleaner

Avoid the following cleaning agents:

- detergents with scouring or abrasive components
- metal cleaning objects such as razor blades or steel spatulas
- steam jet cleaner or very hot water
- cold water with a heated device
- high water pressure, e.g. high-pressure cleaner

Repair

Only the vendor may repair the device. If a repair should be necessary, contact Beckhoff Service (see Chapter 9.1 [Service and Support](#) [[▶ 34](#)]).

7 Troubleshooting

Fault	Cause	Measures
No control panel function	Lack of power supply to the control panel Other cause	Check the power supply cable Call Beckhoff Service
The control panel only works partially or only temporarily (e.g. dark image or none at all)	Defective backlight in the display Components in the control panel defective	Call Beckhoff Service Call Beckhoff Service
Malfunction of the touch screen	Poor or missing functional earth of the device Poor or missing ground connection of the user	Establish functional earth User must stand on the floor with normal shoes
USB error during access with TwinCAT via USB	Cycle times in TwinCAT set to 10 ms (default)	Increase the cycle times to between 50 ms and 80 ms

8 Technical Data

Table 8: Technical data

Product designation	CP29xx-2xxx		
Weight	CP2916: approx. 4.5 kg CP2918: approx. 5.3 kg CP2919: approx. 5.5 kg CP2921: approx. 6 kg		
Supply voltage	22-30 V _{DC} (24 V _{DC} power supply unit, NEC class 2)		
Power consumption	Data sheet for calculating power consumption and power loss in the download finder: https://www.beckhoff.com/en-en/support/download-finder/search-result/?download_group=691754572		
Protection rating	Front IP65, rear IP20		
Vibration resistance (sinusoidal vibration)	EN 60068-2-6:	10 ... 58 Hz:	0.035 mm
		58 ... 500 Hz:	0.5 G (~ 5 m/s ²)
Shock resistance (shock)	EN 60068-2-27:	5 G (~ 50 m/s ²), duration: 30 ms	
EMC interference immunity	conforms to EN 61000-6-2		
EMC interference emission	conforms to EN 61000-6-4		
Permissible ambient temperature	Operation: 0 °C ... +55 °C Transport / storage: -20 °C ... +70 °C		
Permissible relative air humidity	Maximum 95%, no condensation		
Transport and storage	The same values for air humidity and shock resistance are to be observed during transport and storage as in operation. Suitable packaging of the control panel can improve the resistance to impact during transport.		

9 Appendix

In the appendix you will find information for servicing and details of the approvals that your device has.

9.1 Service and support

Beckhoff and its worldwide subsidiaries offer comprehensive service and support, providing fast and competent assistance for all issues relating to Beckhoff products and system solutions.

Beckhoff Service

The Beckhoff Service Center provides support in all forms of after-sales service:

- on-site service
- repair service
- spare parts service
- hotline service

Hotline: + 49 5246/963-460
email: service@beckhoff.com

If your device requires attention, please state its serial number, which you can find on the name plate.

Beckhoff Support

Support offers you comprehensive technical assistance to help you with the application of individual Beckhoff products, and also with other extensive services:

- world-wide support
- design, programming, and commissioning of complex automation systems
- extensive training program for Beckhoff system components

Hotline: + 49 5246/963-157
email: support@beckhoff.com

Headquarters

Beckhoff Automation GmbH & Co. KG
Hülshorstweg 20
33415 Verl
Germany

Phone: + 49 5246/963-0
email: info@beckhoff.de

The addresses of the worldwide Beckhoff branches and agencies can be found on our website at <http://www.beckhoff.com/>.

You can also find further documentation for Beckhoff components there.

9.2 Approvals

Your device has at least the following approvals:

- CE
- EAC
- UKCA
- FCC

You will find all other applicable approvals on the name plate of your device.

FCC approvals for the United States of America

FCC: Federal Communications Commission Radio Frequency Interference Statement

This device was tested and complies with the limits for a digital device of class A, according part 15 of the FCC regulations. These limits are designed to provide adequate protection against adverse interference, if the device is used in a commercial environment. This device generates, uses and may emit radio frequency energy and may cause adverse interference with radio communications, if it is not installed and used in accordance with the operating instructions. If this device is used in a residential area it is likely to cause adverse interference, in which case the user must take appropriate countermeasures in order to eliminate the interference at his own expense.

FCC approvals for Canada

FCC: Canadian Notice

This device does not exceed the class A limits for radiation, as specified by the Radio Interference Regulations of the Canadian Department of Communications.

List of figures

Fig. 1	Structure.....	10
Fig. 2	Voltage connector pin numbering	11
Fig. 3	USB interface pin numbering	12
Fig. 4	DVI interface pin numbering.....	12
Fig. 5	Name plate example	13
Fig. 6	Dimensions 15.6-inch.....	17
Fig. 7	Dimensions 18.5-inch.....	18
Fig. 8	Dimensions 19-inch.....	18
Fig. 9	Dimensions 21.5-inch.....	19
Fig. 10	Without C6030	20
Fig. 11	Positions of the fastening screws.....	20
Fig. 12	C6030 installation.....	20
Fig. 13	Delivery state clamping lever	22
Fig. 14	Wall positioning	23
Fig. 15	Control cabinet installation	23
Fig. 16	Assembly of strain relief housing	25
Fig. 17	Disassembly of the strain relief housing.....	26
Fig. 18	Grounding bolt for functional earthing	27
Fig. 19	Removal from the control cabinet	30
Fig. 20	Removal installation cutout	30

List of tables

Table 1	Legend structure	10
Table 2	Voltage connector pin assignment.....	11
Table 3	USB interface pin assignment.....	12
Table 4	DVI interface pin numbering.....	12
Table 5	Legend name plate	13
Table 6	Connection cables/kits CP29xx.....	14
Table 7	Connection kits CP29xx with C6030	14
Table 8	Technical data.....	33

Beckhoff Automation GmbH & Co. KG
Hülshorstweg 20
33415 Verl
Germany
Phone: +49 5246 9630
info@beckhoff.com
www.beckhoff.com