

BECKHOFF New Automation Technology

Original-Handbuch | DE

CB1076

Computerboard

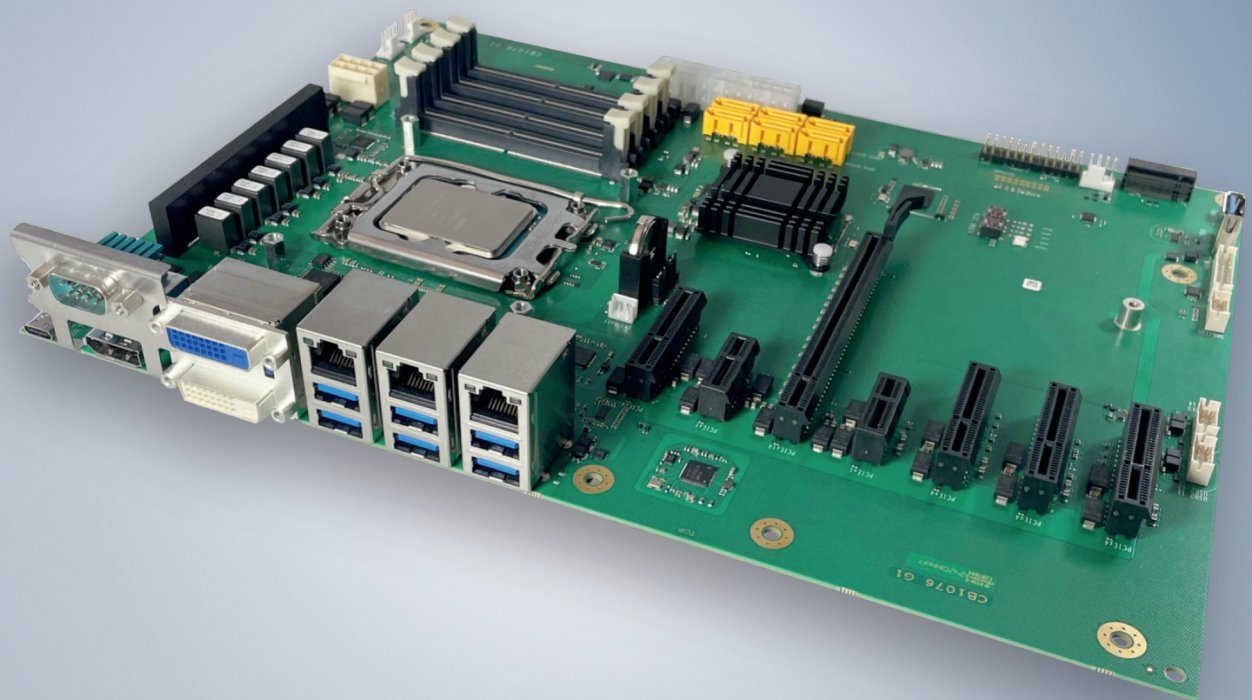

Inhaltsverzeichnis

1	Ausgabestände der Dokumentation	5
2	Hinweise zur Dokumentation	6
3	Sicherheitshinweise	7
4	Übersicht	9
4.1	Eigenschaften	9
4.2	Featureliste	11
4.3	Spezifikationen und Dokumente	12
5	Hinweise zur Informationssicherheit	13
6	Schnittstellen	14
6.1	Schnittstellenübersicht	14
6.2	USB-C Port (P1304).....	16
6.3	FAN 1 – 5 (P500/1/2/3/4)	17
6.4	USB 2.0 (P1602/P1609/P1611)	18
6.5	Serielle Schnittstellen COM2 (P1601).....	19
6.6	Programmier Port (P1305)	20
6.7	Batterie (BT1700/P1701)	21
6.8	Speicher (U600, U700, U601, U701)	22
6.9	Spannungsversorgung (P1614/P1616).....	29
6.10	SATA (P1603 – P1608).....	30
6.11	System Port (P1610).....	30
6.12	M.2 Key-M (P1700)	31
6.13	USB3.1 Gen2 Typ A (P1613).....	34
6.14	GPIO (P1615)	35
6.15	SMB/I ² C (P1600).....	35
6.16	PCIe x4 (P1205/P1206/P1204/P1201)	36
6.17	PCIe x1 (P1200/P1203)	37
6.18	PCIe x16 (P1202).....	38
6.19	LAN 2,5 Gbit und USB 3.1Gen2 (P1402/P1401/P1400).....	41
6.20	DVI-D (P1500A/B).....	43
6.21	Serielle Schnittstelle COM1 (P1403).....	44
6.22	Display Port (P1501)	44
7	BIOS	45
7.1	Benutzung des Setups	45
7.2	Main	46
7.3	Advanced Menu	48
7.3.1	RC ACPI Settings.....	49
7.3.2	CPU Configuration	50
7.3.3	Trusted Computing.....	54
7.3.4	ACPI Settings Disabled.....	55
7.3.5	Hardware Monitor.....	56
7.3.6	AMI Graphic Output Protocol Policy.....	57
7.3.7	PCI Subsystem Settings	57
7.3.8	USB Configuration	58

7.3.9	Network Stack Configuration enabled.....	59
7.3.10	Power Controller Options.....	60
7.3.11	NVMe Configuration.....	61
7.3.12	TLs Auth Configuration.....	62
7.3.13	Intel Rapid Storage Technology.....	64
7.3.14	Intel Ethernet Controller I226-IT.....	65
7.3.15	Intel Ethernet Controller I226-IT.....	66
7.3.16	Driver Health.....	67
7.4	Chipset.....	68
7.4.1	System Agent (SA) Configuration.....	69
7.4.2	PCH-IO Configuration.....	81
7.5	Security.....	97
7.5.1	Secure Boot.....	98
7.6	Boot.....	111
7.6.1	Advanced Fixed Boot Order Parameters.....	112
7.7	Save & Exit.....	113
8	Mechanische Zeichnungen.....	114
8.1	Leiterplatte: Abmessungen.....	114
8.2	Leiterplatte: Montage-Bohrungen.....	115
9	Technische Daten.....	116
9.1	Elektrische Daten.....	116
9.2	Umgebungsbedingungen.....	116
9.3	Thermische Spezifikationen.....	117
10	Anhang I: Post-Codes.....	118
11	Anhang II: Ressourcen.....	119
11.1	Interrupt.....	119
11.2	PCI-Devices.....	120
11.3	SMB-Devices.....	121
12	Support und Service.....	122

1 Ausgabestände der Dokumentation

Version	Änderungen
0.1	Erste vorläufige Version, HW-Version G1
1.0	Erstes Release mit BIOS Version 0.08, Revision 1
1.1	Korrigierte GPIO Schnittstelle (P1615)

2 Hinweise zur Dokumentation

Diese Beschreibung wendet sich ausschließlich an ausgebildetes Fachpersonal der Steuerungs- und Automatisierungstechnik, das mit den geltenden nationalen Normen vertraut ist.

Zur Installation und Inbetriebnahme der Komponenten ist die Beachtung der Dokumentation und der nachfolgenden Hinweise und Erklärungen unbedingt notwendig.

Das Fachpersonal ist verpflichtet, für jede Installation und Inbetriebnahme die zu dem betreffenden Zeitpunkt veröffentlichte Dokumentation zu verwenden.

Das Fachpersonal hat sicherzustellen, dass die Anwendung bzw. der Einsatz der beschriebenen Produkte alle Sicherheitsanforderungen, einschließlich sämtlicher anwendbaren Gesetze, Vorschriften, Bestimmungen und Normen erfüllt.

Dokumentenursprung

Diese Dokumentation ist in deutscher Sprache verfasst. Alle weiteren Sprachen werden vom deutschen Original abgeleitet.

Disclaimer

Diese Dokumentation wurde sorgfältig erstellt. Die beschriebenen Produkte werden jedoch ständig weiter entwickelt.

Wir behalten uns das Recht vor, die Dokumentation jederzeit und ohne Ankündigung zu überarbeiten und zu ändern.

Aus den Angaben, Abbildungen und Beschreibungen in dieser Dokumentation können keine Ansprüche auf Änderung bereits gelieferter Produkte geltend gemacht werden.

Marken

Beckhoff®, TwinCAT®, EtherCAT®, EtherCAT G®, EtherCAT G10®, EtherCAT P®, Safety over EtherCAT®, TwinSAFE®, XFC®, und XTS® und XPlanar®, sind eingetragene und lizenzierte Marken der Beckhoff Automation GmbH.

Die Verwendung anderer in dieser Dokumentation enthaltenen Marken oder Kennzeichen durch Dritte kann zu einer Verletzung von Rechten der Inhaber der entsprechenden Bezeichnungen führen.

Patente

Die EtherCAT-Technologie ist patentrechtlich geschützt, insbesondere durch folgende Anmeldungen und Patente:

EP1590927, EP1789857, EP1456722, EP2137893, DE102015105702

mit den entsprechenden Anmeldungen und Eintragungen in verschiedenen anderen Ländern.



EtherCAT® ist eine eingetragene Marke und patentierte Technologie lizenziert durch die Beckhoff Automation GmbH, Deutschland

Copyright

© Beckhoff Automation GmbH & Co. KG, Deutschland.

Weitergabe sowie Vervielfältigung dieses Dokuments, Verwertung und Mitteilung seines Inhalts sind verboten, soweit nicht ausdrücklich gestattet.

Zuwendungen verpflichten zu Schadenersatz. Alle Rechte für den Fall der Patent-, Gebrauchsmuster- oder Geschmacksmustereintragung vorbehalten.

3 Sicherheitshinweise

Sicherheitsbestimmungen

Beachten Sie die folgenden Sicherheitshinweise und Erklärungen!
 Produktspezifische Sicherheitshinweise finden Sie auf den folgenden Seiten oder in den Bereichen Montage, Verdrahtung, Inbetriebnahme usw.

Haftungsausschluss

Die gesamten Komponenten werden je nach Anwendungsbestimmungen in bestimmten Hard- und Software-Konfigurationen ausgeliefert. Änderungen der Hard- oder Software-Konfiguration, die über die dokumentierten Möglichkeiten hinausgehen, sind unzulässig und bewirken den Haftungsausschluss der Beckhoff Automation GmbH & Co. KG.

Qualifikation des Personals

Diese Beschreibung wendet sich ausschließlich an ausgebildetes Fachpersonal der Steuerungs-, Automatisierungs- und Antriebstechnik, das mit den geltenden Normen vertraut ist.

Erklärung der Symbole

In der vorliegenden Dokumentation werden die folgenden Symbole mit einem nebenstehenden Sicherheitshinweis oder Hinweistext verwendet. Die Sicherheitshinweise sind aufmerksam zu lesen und unbedingt zu befolgen!

⚠ GEFAHR
<p>Akute Verletzungsgefahr!</p> <p>Wenn der Sicherheitshinweis neben diesem Symbol nicht beachtet wird, besteht unmittelbare Gefahr für Leben und Gesundheit von Personen!</p>

⚠ WARNUNG
<p>Verletzungsgefahr!</p> <p>Wenn der Sicherheitshinweis neben diesem Symbol nicht beachtet wird, besteht Gefahr für Leben und Gesundheit von Personen!</p>

⚠ VORSICHT
<p>Schädigung von Personen!</p> <p>Wenn der Sicherheitshinweis neben diesem Symbol nicht beachtet wird, können Personen geschädigt werden!</p>

HINWEIS
<p>Schädigung von Umwelt oder Geräten</p> <p>Wenn der Hinweis neben diesem Symbol nicht beachtet wird, können Umwelt oder Geräte geschädigt werden.</p>



Tip oder Fingerzeig

Dieses Symbol kennzeichnet Informationen, die zum besseren Verständnis beitragen.



Dieses Symbol kennzeichnet wichtige Informationen bezüglich der UL-Zulassung.



Bestimmungsgemäße Verwendung

Das Computerboard CB1076 wurde ausschließlich für die Konfiguration in Automatisierungsprozessen konstruiert und entwickelt. Dazu ist das Board mit externen Schnittstellen ausgestattet, um digitale oder analoge Signale aufzunehmen oder auszugeben oder an übergeordnete Komponenten weiterzuleiten.

Die angegebenen Grenzwerte für elektrische- und technische Daten müssen eingehalten werden.

Jegliche davon abweichende Verwendung gilt als nicht bestimmungsgemäß.

4 Übersicht

4.1 Eigenschaften

Das CB1076 ist ein Industrie-Motherboard im ATX-Formfaktor. Es basiert auf Intel®'s aktueller Hybrid-Technologie. Intel® Prozessoren der 12. Und 13. Generation (Core™, Celeron™ und Pentium) sind verbaut. Als Chipsatz ist der Intel® R680E-PCH Chipsatz eingesetzt.

Dieses neue Hybrid-Design verfügt über eine Kombination aus Performance- und Efficient-Cores. Es stehen bis zu 24 Kerne zur Verfügung. Über vier SO-DIMM-Steckplätze kann es mit bis zu 128GByte Speicher ausgestattet werden. Eine maximale Taktrate von bis zu 5600MHz ist möglich.

Die Vielzahl von internen und externen Anschlüssen machen das CB1076 zu einem sehr universell einsetzbaren Motherboard:

- 14x USB-Schnittstellen, davon 7x USB3.1 Gen2, 1x USB-C, 6x USB2.0
- 1x LAN-Anschluss 1Gb
- 2x LAN-Anschlüsse 2,5Gb
- DVI/HDMI- und DisplayPort-Anschluss
- 1x M.2 Key M (SATA/NVME)
- 1x PCIe x16-Steckplatz
- 2x serielle Schnittstellen, 1x extern, 1x onboard
- 2x PCIe x1
- 4x PCIe x4
- 6x SATA-Anschlüsse 6G onboard

Über das integrierte Trusted Platform Modul (TPM) als Trusted Computing Platform und bietet das Board grundlegende Sicherheitsfunktionen.



Abb. 1: CB1076 Blockschaftbild

4.2 Featureliste

CB1076	ATX-Board
CPU	Intel® Prozessoren der 12./13. Generation Alder Lake und Raptor Lake Intel® Celeron® G6900E Intel® Pentium® G7400E Intel® Core™ i3-13100E Intel® Core™ i5-13400E Intel® Core™ i7-13700E Intel® Core™ i9-13900E
Chipsatz	Intel® R680E-PCH
Sockel	LGA 1700
Speicher	4x SO-DIMM bis zu 128GB, DDR5 bis zu 5600MHz
I/O Extern	1x USB-C 6x USB3.1 Gen2 1x LAN 1Gb 2x LAN 2,5Gb 1x DP 1.2 2x DVI-D (DVI oder HDMI 1.4) 1x COM
I/O Intern	1x M.2 (M) (NVMe™) 1x COM 6x SATA 3.0, RAID 0/1/5/10 2x PCIe® x1 (3.0) 4x PCIe® x4 (3.0) 1x PCIe® x16 (5.0) 6x USB 2.0 1x USB3 8x GPIO 5x FAN (davon 3 geregelte Lüfter) 1x SMB-Anschluss 1x 2x9Pol-Stecker System 1x 2x13Pol-Stecker ATX-Bh-System
Grafikauflösung	DisplayPort1.2: 4096x2304@60 Hz HDMI1.4: 4096x2160@30 Hz
RTC	Interne oder externe CMOS-Batterie
BIOS	AMI® Aptio V
Stromversorgung	Standard ATX-Netzteil
Format	305 x 220 mm

i Verfügbarkeit der Prozessoren

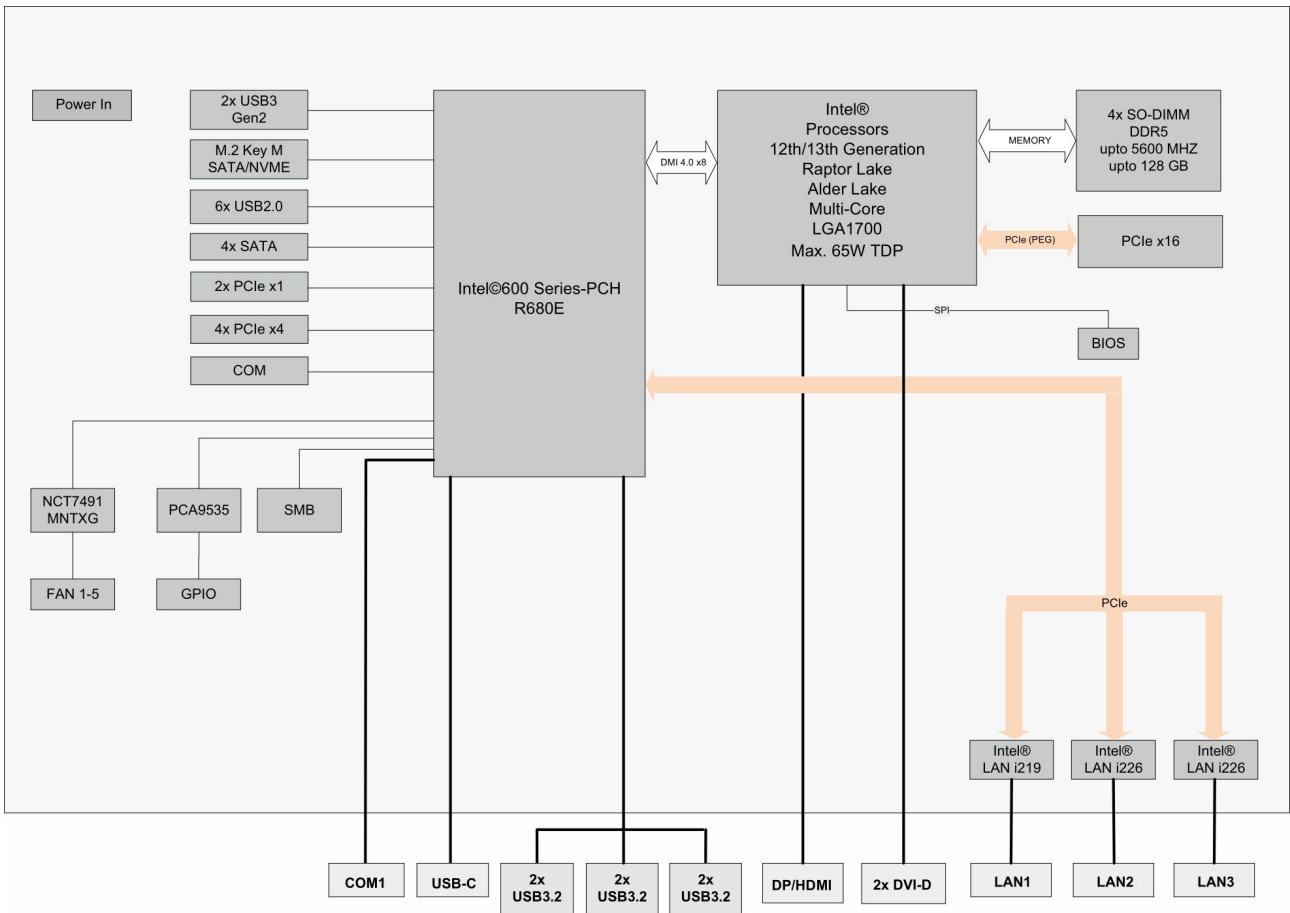
Die Featureliste führt alle bestellbaren Prozessoren auf. Ihre tatsächliche Verfügbarkeit ist herstellerabhängig.

4.3 Spezifikationen und Dokumente

Für die Erstellung dieses Handbuchs bzw. als weiterführende technische Dokumentation wurden die folgenden Dokumente, Spezifikationen oder Internetseiten verwendet.

- **PCI-Spezifikation**
 - Version 2.3 bzw. 3.0
 - www.pcisig.com
- **PCI Express® Base Specification**
 - Version 5.0
 - www.pcisig.com
- **ACPI-Spezifikation**
 - Version 5.0
 - www.acpi.info
- **ATA/ATAPI-Spezifikation**
 - Version 7 Rev. 1
 - www.t13.org
- **USB-Spezifikationen**
 - www.usb.org
- **SM-Bus-Spezifikation**
 - Version 2.0
 - www.smbus.org
- **Intel®-Chipbeschreibungen**
 - Intel® Core™ Processor Product Family datasheet
 - www.intel.com
- **Intel®-Chipbeschreibung**
 - i219 Datasheet
 - i225/226 Datasheet
 - www.intel.com
- **SMSC®-Chipbeschreibung**
 - SCH3114 Datasheet (NDA erforderlich)
 - www.smsc.com
- **American Megatrends®**
 - Aptio™ Text Setup Environment (TSE) User Manual
 - www.ami.com
- **American Megatrends®**
 - Aptio™ 5.x Status Codes
 - www.ami.com

5 Hinweise zur Informationssicherheit

Die Produkte der Beckhoff Automation GmbH & Co. KG (Beckhoff) sind, sofern sie online zu erreichen sind, mit Security-Funktionen ausgestattet, die den sicheren Betrieb von Anlagen, Systemen, Maschinen und Netzwerken unterstützen. Trotz der Security-Funktionen sind die Erstellung, Implementierung und ständige Aktualisierung eines ganzheitlichen Security-Konzepts für den Betrieb notwendig, um die jeweilige Anlage, das System, die Maschine und die Netzwerke gegen Cyber-Bedrohungen zu schützen. Die von Beckhoff verkauften Produkte bilden dabei nur einen Teil des gesamtheitlichen Security-Konzepts. Der Kunde ist dafür verantwortlich, dass unbefugte Zugriffe durch Dritte auf seine Anlagen, Systeme, Maschinen und Netzwerke verhindert werden. Letztere sollten nur mit dem Unternehmensnetzwerk oder dem Internet verbunden werden, wenn entsprechende Schutzmaßnahmen eingerichtet wurden.

Zusätzlich sollten die Empfehlungen von Beckhoff zu entsprechenden Schutzmaßnahmen beachtet werden. Weiterführende Informationen über Informationssicherheit und Industrial Security finden Sie in unserem <https://www.beckhoff.de/secguide>.

Die Produkte und Lösungen von Beckhoff werden ständig weiterentwickelt. Dies betrifft auch die Security-Funktionen. Aufgrund der stetigen Weiterentwicklung empfiehlt Beckhoff ausdrücklich, die Produkte ständig auf dem aktuellen Stand zu halten und nach Bereitstellung von Updates diese auf die Produkte aufzuspielen. Die Verwendung veralteter oder nicht mehr unterstützter Produktversionen kann das Risiko von Cyber-Bedrohungen erhöhen.

Um stets über Hinweise zur Informationssicherheit zu Produkten von Beckhoff informiert zu sein, abonnieren Sie den RSS Feed unter <https://www.beckhoff.de/secinfo>.

6 Schnittstellen

6.1 Schnittstellenübersicht

Die Abbildungen zeigen die Schnittstellen des CB1076-Boards in einer Top-Ansicht. Der Tabelle entnehmen Sie die Funktion der jeweiligen Schnittstelle sowie einen Verweis auf die Handbuchseite, für weitergehende Informationen. Die Auflistung erfolgt im Uhrzeigersinn, beginnend bei P1304 USB-C



Abb. 2: CB1076 Schnittstellen

Nummer	Funktion (Bezeichnung)	Seite
P1304	USB-C	USB-C Port (P1304) [► 16]
P501	4Pol-Stecker (FAN)	FAN 1 – 5 (P500/1/2/3/4) [► 17]
P1602	2x5Pol-Stecker (USB2.0)	USB 2.0 (P1602/P1609/P1611) [► 18]
P1601	2x5Pol-Stecker (COM2)	Serielle Schnittstellen COM2 (P1601) [► 19]
P1305	5Pol-Stecker (Programmier Port)	Programmier Port (P1305) [► 20]
P1701	2Pol-Stecker (RTC-BAT)	Batterie (BT1700/P1701) [► 21]
BT1700	Batteriehalter für CR2032	Batterie (BT1700/P1701) [► 21]
J1700/ J1701	Jumper Clear CMOS 1/CMOS2	
U600/700	SO-DIMM262 A1 und A2	Speicher (U600, U700, U601, U701) [► 22]
P1614	2x4Pol-Stecker MiniFit 12 V	Spannungsversorgung (P1614/P1616) [► 29]
U601/701	SO-DIMM262 B1 und B2	Speicher (U600, U700, U601, U701) [► 22]
P504	4Pol-Stecker (FAN)	FAN 1 – 5 (P500/1/2/3/4) [► 17]
P500	4Pol-Stecker (FAN)	FAN 1 – 5 (P500/1/2/3/4) [► 17]
P1616	2x12Pol-Stecker ATX-Power	Spannungsversorgung (P1614/P1616) [► 29]
P1604/06/08	SATA 2/4/6	SATA (P1603 – P1608) [► 30]
P1603/05/07	SATA 1/3/5	SATA (P1603 – P1608) [► 30]
P1612	2x9Pol-Stecker-System	Reserviert
P1610	2x13Pol-Stecker ATX-Bh-System	System Port (P1610) [► 30]
P502	4Pol-Stecker FAN	FAN 1 – 5 (P500/1/2/3/4) [► 17]
P1700	M.2M PCIe/SATA	M.2 Key-M (P1700) [► 31]
P503	4Pol-Stecker (FAN)	FAN 1 – 5 (P500/1/2/3/4) [► 17]
P1613	Stecker USB3.0	USB3.1 Gen2 Typ A (P1613) [► 34]
P1615	2x10Pol-Stecker (GPIO)	GPIO (P1615) [► 35]
P1600	2x5Pol-Stecker (SMBus)	SMB/I²C (P1600) [► 35]
P1611	2x5Pol-Stecker USB 2.0	USB 2.0 (P1602/P1609/P1611) [► 18]
P1609	2x5Pol-Stecker USB 2.0	USB 2.0 (P1602/P1609/P1611) [► 18]
P1205/06/04	PCIe x4 Sockel	PCIe x4 (P1205/P1206/P1204/P1201) [► 36]
P1200	PCIe x1 Sockel	PCIe x1 (P1200/P1203) [► 37]
P1202	PCIe x16 Sockel	PCIe x16 (P1202) [► 38]
P1203	PCIe x1 Sockel	PCIe x1 (P1200/P1203) [► 37]
P1201	PCIe x4 Sockel	PCIe x4 (P1205/P1206/P1204/P1201) [► 36]
P1402	LAN 2,5Gb + USB3.1Gen2	LAN 2,5 Gbit und USB 3.1Gen2 (P1402/P1401/ P1400) [► 41]
P1401	LAN 2,5Gb + USB3.1Gen2	LAN 2,5 Gbit und USB 3.1Gen2 (P1402/P1401/ P1400) [► 41]
P1400	LAN 1Gb + USB3.1Gen2	LAN 2,5 Gbit und USB 3.1Gen2 (P1402/P1401/ P1400) [► 41]
P1500	DVI-D A+B	DVI-D (P1500A/B) [► 43]
P1403	DSUB9M (COM1)	Serielle Schnittstelle COM1 (P1403) [► 44]
P1501	DisplayPort	Display Port (P1501) [► 44]

6.2 USB-C Port (P1304)

24-poliger USB-C-Stecker. Über diesen Stecker können Signale mit bis zu 10 Gbit/s herausgeführt werden.

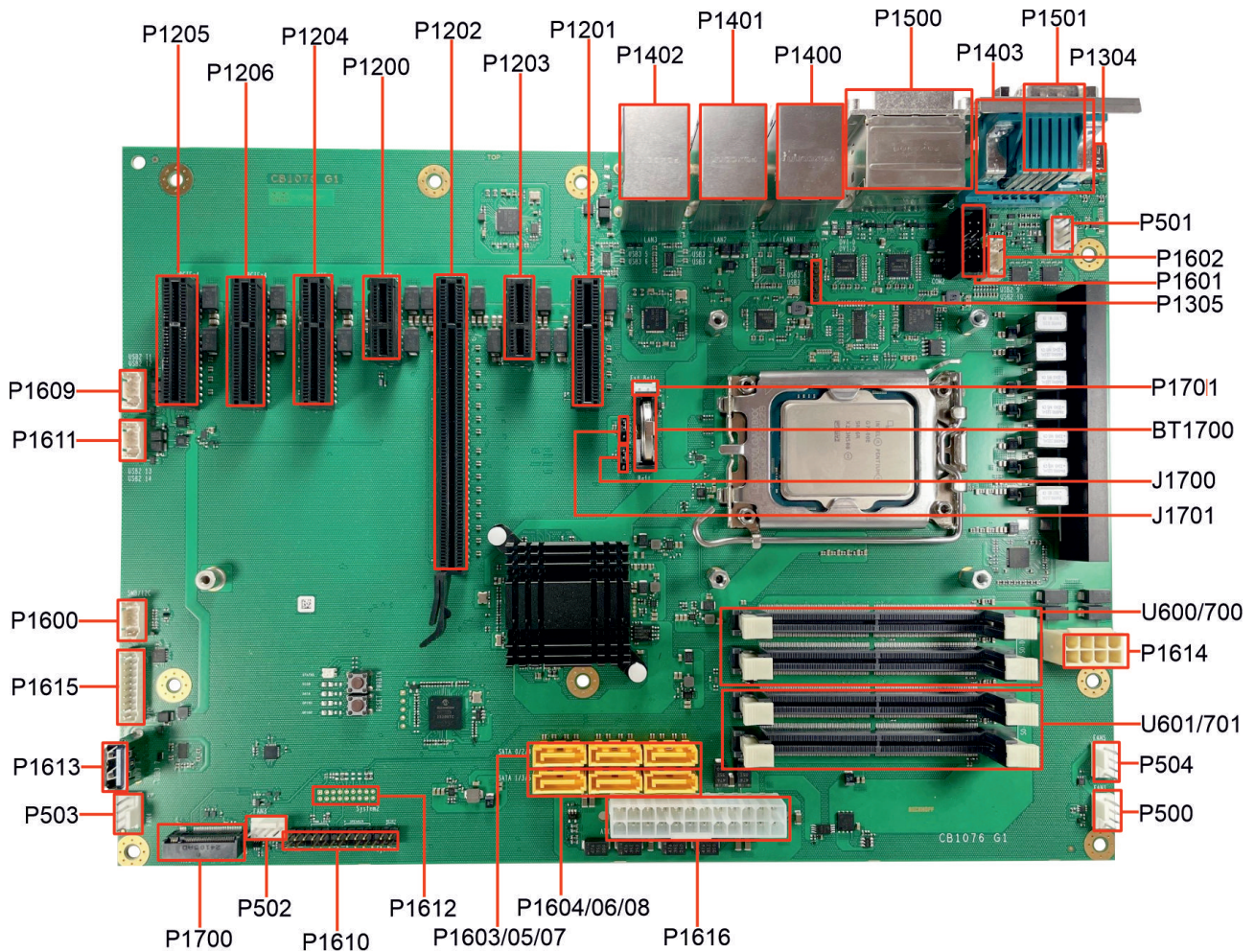

Abb. 3: CB1076 USB-C

Pinbelegung USB-C					
Beschreibung	Name	Pin		Name	Beschreibung
Masse	GND	A1	B12	GND	Masse
Transmit+	TX1+	A2	B11	RX1+	Receive+
Transmit-	TX1-	A3	B10	RX1-	Receive-
Spannung	VBUS1	A4	B9	VBUS3	Spannung
Konfigurationskanal	CC1	A5	B8	SBU2	Sideband Use2
USB2.0-Signal+	D0+	A6	B7	D1-	USB2.0-Signal-
USB2.0-Signal-	D0-	A7	B6	D1+	USB2.0-Signal+
Sideband Use1	SBU1	A8	B5	Vconn/ CC2	Konfigurationskanal
Spannung	VBUS2	A9	B4	VBUS4	Spannung 5 V
Receive-	RX2-	A10	B3	TX2-	Transmit-
Receive+	RX2+	A11	B2	TX2+	Transmit+
Masse	GND	A12	B1	GND	Masse

6.3 FAN 1 – 5 (P500/1/2/3/4)

Die Baugruppe verfügt über fünf 4-polige Lüfteranschlüsse. Damit können Sie Lüfter mit einer Versorgungsspannung von 12 Volt direkt an die Baugruppe anschließen. Die Anschlüsse FAN1, FAN2 und FAN3 verfügen über eine Drehzahlüberwachungsfunktion. Wenn diese genutzt werden soll, muss der angeschlossene Lüfter ein entsprechendes Tachometer-Signal liefern.

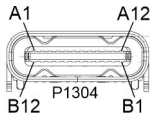

Abb. 4: CB1076 FAN 1-5

Pinbelegung FAN 1 (P500)			
P500	Pin	Name	Beschreibung
	1	FANON	Masse geschaltet Lüfter 1
	2	12V	12 V
	3	TACH1	Überwachung Lüfter 1
	4	PWM1	Powermanagement Lüfter 1

Pinbelegung FAN 2 (P501)			
P501	Pin	Name	Beschreibung
	1	FANON	Masse geschaltet Lüfter 2
	2	12V	12 V
	3	TACH2	Überwachung Lüfter 2
	4	PWM2	Powermanagement Lüfter 2

Pinbelegung FAN 3 (P502)			
P502	Pin	Name	Beschreibung
	1	FANON	Masse geschaltet Lüfter 3
	2	12V	12 V
	3	TACH3	Überwachung Lüfter 3
	4	PWM3	Powermanagement Lüfter 3

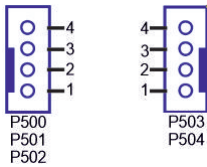
Pinbelegung FAN 4 (P503)			
P503	Pin	Name	Beschreibung
	1	FANON	Masse geschaltet Lüfter 4
	2	12V	12 V
	3	N/C	
	4	PWM3	Powermanagement Lüfter 3

Pinbelegung FAN 5 (P504)			
P504	Pin	Name	Beschreibung
	1	FANON	Masse geschaltet Lüfter 5
	2	12V	12 V
	3	N/C	
	4	PWM1	Powermanagement Lüfter 1



Parallelbelegung bei FAN1/5 und FAN 3/4

Diese Stecker werden parallel über das PWM-Signal versorgt.

6.4 USB 2.0 (P1602/P1609/P1611)

Sechs USB-Signale werden über diese drei 2x5-polige Wannenstecker zur Verfügung gestellt.

Die Signale entsprechen der USB-Spezifikation 2.0.

Durch das BIOS können alle notwendigen Einstellungen für USB durchgeführt werden. Es ist zu beachten, dass die Funktionalität „USB-Maus und Tastatur“ des BIOS-Setup nur benötigt wird, wenn das Betriebssystem keine USB-Unterstützung bietet. Für Einstellungen im Setup und zum Booten von Windows mit einer angeschlossenen USB-Maus und Tastatur sollte diese Funktion nicht gewählt werden, weil dies zu erheblichen Leistungseinschränkungen führen würde.

Die einzelnen USB-Schnittstellen können bis zu 500mA Strom liefern und sind elektronisch abgesichert.



Abb. 5: CB1076 USB 2.0 intern

Pinbelegung interne USB 2.0-Stecker:					
Beschreibung	Name	Pin		Name	Beschreibung
5V für USB	VCC	1	6	VCC	5V für USB
Minus-Datenkanal USB	USB-	2	7	USB-	Minus-Datenkanal USB
Plus-Datenkanal USB	USB+	3	8	USB+	Plus-Datenkanal USB
Masse	GND	4	9	GND	Masse
Nicht verbunden	N/C	5	10	N/C	Nicht verbunden

6.5 Serielle Schnittstellen COM2 (P1601)

Auf dem Board ist eine weitere serielle Schnittstelle COM2 in einem 2x5-poligen Wannenstecker verbaut. Die Signale entsprechen der RS232-Norm.

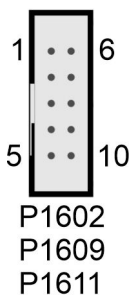
Die Port-Adresse und der benutzte Interrupt werden mit Hilfe des BIOS-Setups eingestellt.

2x5-poliger Wannenstecker:



Abb. 6: CB1076 COM 2

Pinbelegung COM-Stecker					
Beschreibung	Name	Pin		Name	Beschreibung
Data Carrier Detect-	DCD#	1	2	DSR#	Data Set Ready-
Receive Data	RXD	3	4	RTS	Request to Send
Transmit Data	TXD	5	6	CTS	Clear to Send
Data Terminal Ready-	DTR#	7	8	RI#	Ring Indicator-
Masse	GND	9	10	VCC	Versorgungsspannung 5 V

6.6 Programmier Port (P1305)

Über diesen 5-poligen Anschluss können Sie Programmiersignale auf das Board übertragen. Die Versorgungsspannung beträgt 3.3 Volt.

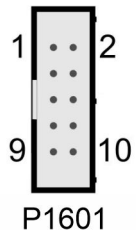
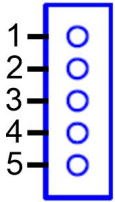

P1305

Abb. 7: CB1076 Programmier Port

Pinbelegung Programmier Port		
Pin	Signal	Beschreibung
1	3,3 V	Versorgungsspannung 3,3 V
2	EEP-SMBCLK	SMB-Clock
3	EEP-SMBDAT	SMB Data
4	PMCALERT#	PMC Alert-
5	GND	Masse

6.7 Batterie (BT1700/P1701)

Das Board wird mit einem CR2032-Batteriehalter (BT1700) samt 3V-Batterie ausgeliefert, kann aber zusätzlich über einen zweipoligen Gehäusestecker (P1701) an eine externe Batterie angeschlossen werden, um die integrierte Uhr auch bei Wegfall der Versorgungsspannung weiter zu versorgen.



Abb. 8: CB1076 Batterie

Pinbelegung RTC-Batteriestecker		
Pin	Name	Beschreibung
1	BATT	3,3 V Batteriespannung
2	GND	Masse

6.8 Speicher (U600, U700, U601, U701)

Auf dem CB1076-Board sind vier stehende SO-DIMM-Speichersteckplätze, DDR5- 5600 MT/s, max. 128 GBRAM verbaut. Aus technischen und mechanischen Gründen ist es möglich, dass bestimmte Speichermodule nicht eingesetzt werden können. Informieren Sie sich bei Ihrem Distributor über die empfohlenen Speichermodule.

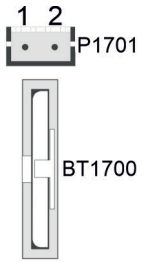
HINWEIS

Speichermodule

Achten Sie bei der Bestückung der Speichersockel darauf, dass Sie identische Speichermodule einsetzen.

Alle Timing-Parameter für die unterschiedlichen Fabrikate und Ausbaustufen werden durch das BIOS automatisch eingestellt.



Abb. 9: CB1076 SODIMM-262

Pinbelegung Speichersockel U600/U700					
Beschreibung	Signal	Pin1		Signal	Beschreibung
Versorgungsspannung 5 V	M_VIN	1	2	SA0	Masse
Versorgungsspannung 5 V	M_VIN	3	4	SCL	SMBus-CLK
Reserviert	Res1	5	6	SDA	SMBus-Data
Powergood	PWRGOOD	7	8	PWR_EN	Power Enable
Masse	GND	9	10	GND	Masse
Datenleitung A3	ADQ0	11	12	ADQ1	Datenleitung A2
Masse	GND	13	14	GND	Masse
Datenleitung A0	ADQ2	15	16	ADQ3	Datenleitung A1
Masse	GND	17	18	GND	Masse
Masse	ADM0	19	20	ADQS#0	Data Strobe A0 -
Masse	GND	21	22	ADQS0	Data Strobe A0+
Datenleitung A5	ADQ4	23	24	GND	Masse
Masse	GND	25	26	ADQ5	Datenleitung A6
Datenleitung A4	ADQ6	27	28	GND	Masse
Masse	GND	29	30	ADQ7	Datenleitung A7
Datenleitung A11	ADQ8	31	32	GND	Masse
Masse	GND	33	34	ADQ9	Datenleitung A10
Datenleitung A8	ADQ10	35	36	GND	Masse
Masse	GND	37	38	ADQ11	Datenleitung A9
Data Strobe A1 -	ADQS#1	39	40	GND	Masse
Data Strobe A1 +	ADQS1	41	42	ADM1	Masse
Masse	GND	43	44	GND	Masse
Datenleitung A12	ADQ12	45	46	ADQ13	Datenleitung A13
Masse	GND	47	48	GND	Masse
Datenleitung A15	ADQ14	49	50	ADQ15	Datenleitung A14
Masse	GND	51	52	GND	Masse
Datenleitung A17	ADQ16	53	54	ADQ17	Datenleitung A16
Masse	GND	55	56	GND	Masse
Datenleitung A19	ADQ18	57	58	ADQ19	Datenleitung A18
Masse	GND	59	60	GND	Masse
Masse	ADM2	61	62	ADQS#2	Data Strobe A2 -
Masse	GND	63	64	ADQS2	Data Strobe A2 +
Datenleitung A20	ADQ20	65	66	GND	Masse
Masse	GND	67	68	ADQ21	Datenleitung A21
Datenleitung A23	ADQ22	69	70	GND	Masse
Masse	GND	71	72	ADQ23	Datenleitung A22
Datenleitung A25	ADQ24	73	74	GND	Masse
Masse	GND	75	76	ADQ25	Datenleitung A24
Datenleitung A27	ADQ26	77	78	GND	Masse
Masse	GND	79	80	ADQ27	Datenleitung A26
Data Strobe A3 -	ADQS#3	81	82	GND	Masse
Data Strobe A3 +	ADQS 3	83	84	ADM3	Masse
Masse	GND	85	86	GND	Masse
Datenleitung A30	DQ28	87	88	ADQ29	Datenleitung A31
Masse	GND	89	90	GND	Masse
Datenleitung A28	ADQ30	91	92	ADQ31	Datenleitung A29

Pinbelegung Speichersockel U600/U700					
Beschreibung	Signal	Pin1		Signal	Beschreibung
Masse	GND	93	94	GND	Masse
Datenleitung A32	ACB0	95	96	ACB1	Datenleitung A33
Masse	GND	97	98	GND	Masse
Datenleitung A35	ACB2	99	100	ADQS#4	Data Strobe A4 -
Masse	GND	101	102	ADQS4	Data Strobe A4 +
Datenleitung A34	ACB3	103	104	GND	Masse
Masse	GND	105	106	ACS#0	Control A0 -
Command A0	ACA0	107	108	ALERT#	Alert -
Command A1	ACA1	109	110	ACS#1	Control A1 -
Masse	GND	111	112	GND	Masse
Command A2	ACA2	113	114	ACA3	Command A3
Command A4	ACA4	115	116	ACA5	Command A5
Masse	GND	117	118	GND	Masse
Command A6	ACA6	119	120	ACA7	Command A7
Command A8	ACA8	121	122	ACA9	Command A9
Masse	GND	123	124	GND	Masse
Command A10	ACA10	125	126	ACA11	Command A11
Command A12	ACA12	127	128	RES2	Reserviert
Masse	GND	129	130	GND	Masse
Clock-Signal A0 +	ACK0	131	132	ACK1	Clock-Signal A1+
Clock-Signal A0 -	ACK#0	133	134	ACK#1	Clock-Signal A1-
Masse	GND	135	136	Masse	GND
Clock-Signal B0 +	BCK0	137	138	BCK1	Clock-Signal B1 +
Clock-Signal B0 -	BCK#0	139	140	BCK#1	Clock-Signal B1 -
Masse	GND	141	142	GND	Masse
Reserviert	RES3	143	144	BCA12	Command B12
Command B11	BCA11	145	146	BCA10	Command B10
Masse	GND	147	148	GND	Masse
Command B9	BCA9	149	150	BCA8	Command B8
Command B7	BCA7	151	152	BCA6	Command B6
Masse	GND	153	154	GND	Masse
Command B5	BCA5	155	156	BCA4	Command B4
Command B3	BCA3	157	158	BCA2	Command B2
Masse	GND	159	160	GND	Masse
Command 0 -	BCS#0	161	162	BCA1	Command B1
Reset	RESET	163	164	BCA0	Command B0
Command 1 -	BCS#1	165	166	GND	Masse
Masse	GND	167	168	BCB0	Datenleitung B35
Data Strobe B4 -	BDQS#4	169	170	GND	Masse
Data Strobe B4 +	BDQS4	171	172	BCB1	Datenleitung B32
Masse	GND	173	174	GND	Masse
Datenleitung B33	BCB3	175	176	BCB2	Datenleitung B34
Masse	GND	177	178	GND	Masse
Datenleitung B3	BDQ0	179	180	BDQ1	Datenleitung B2
Masse	GND	181	182	GND	Masse
Datenleitung B0	BDQ2	183	184	BDQ3	Datenleitung B1
Masse	GND	185	186	GND	Masse

Pinbelegung Speichersockel U600/U700					
Beschreibung	Signal	Pin1		Signal	Beschreibung
Masse	BDM0	187	188	BDQS#0	Data Strobe B0 -
Masse	GND	189	190	BDQS0	Data Strobe B0 +
Datenleitung B4	BDQ4	191	192	GND	Masse
Masse	GND	193	194	BDQ5	Datenleitung B5
Datenleitung B6	BDQ6	195	196	GND	Masse
Masse	GND	197	198	BDQ7	Datenleitung B7
Datenleitung B8	BDQ8	199	200	GND	Masse
Masse	GND	201	202	BDQ9	Datenleitung B10
Datenleitung B11	BDQ10	203	204	GND	Masse
Masse	GND	205	206	BDQ11	Datenleitung B9
Data Strobe B1 -	BDQS#1	207	208	GND	Masse
Data Strobe B1 +	BDQS1	209	210	BDM1	Masse
Masse	GND	211	212	GND	Masse
Datenleitung B12	BDQ12	213	214	BDQ13	Datenleitung B13
Masse	GND	215	216	GND	Masse
Datenleitung B15	BDQ14	217	218	BDQ15	Datenleitung B14
Masse	GND	219	220	GND	Masse
Datenleitung B16	BDQ16	221	222	BDQ17	Datenleitung B17
Masse	GND	223	224	GND	Masse
Datenleitung B18	BDQ18	225	226	BDQ19	Datenleitung B19
Masse	GND	227	228	GND	Masse
Masse	BDM2	229	230	BDQS#2	Data Strobe B2 -
Masse	GND	231	232	BDQS2	Data Strobe B2 +
Datenleitung B23	BDQ20	233	234	GND	Masse
Masse	GND	235	236	BDQ21	Datenleitung B21
Datenleitung B22	BDQ22	237	238	GND	Masse
Masse	GND	239	240	BDQ23	Datenleitung B20
Datenleitung B25	BDQ24	241	242	GND	Masse
Masse	GND	243	244	BDQ25	Datenleitung B24
Datenleitung B22	BDQ26	245	246	GND	Masse
Masse	GND	247	248	BDQ27	Datenleitung B26
Data Strobe B3 -	BDQS#3	249	250	GND	Masse
Data Strobe B3 +	BDQS3	251	252	BDM3	Masse
Masse	GND	253	254	GND	Masse
Datenleitung B31	BDQ28	255	256	BDQ29	Datenleitung B28
Masse	GND	257	258	GND	Masse
Datenleitung B29	BDQ30	259	260	BDQ31	Datenleitung B30
Masse	GND	261	262	GND	Masse

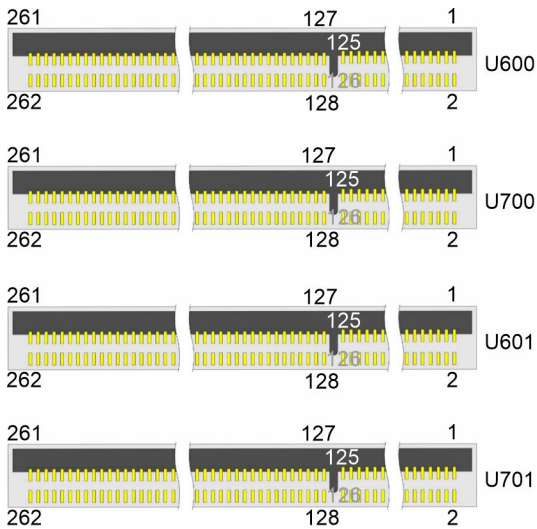
Pinbelegung Speichersockel U601/U701					
Beschreibung	Signal	Pin1		Signal	Beschreibung
Versorgungsspannung 5 V	M_VIN	1	2	SA0	Masse
Versorgungsspannung 5 V	M_VIN	3	4	SCL	SMBus-CLK
Reserviert	Res1	5	6	SDA	SMBus-Data
Powergood	PWRGOOD	7	8	PWR_EN	Power Enable
Masse	GND	9	10	GND	Masse
Datenleitung A0	ADQ0	11	12	ADQ1	Datenleitung A1
Masse	GND	13	14	GND	Masse
Datenleitung A2	ADQ2	15	16	ADQ3	Datenleitung A3
Masse	GND	17	18	GND	Masse
Masse	ADM0	19	20	ADQS#0	Data Strobe A0 -
Masse	GND	21	22	ADQS0	Data Strobe A0+
Datenleitung A5	ADQ4	23	24	GND	Masse
Masse	GND	25	26	ADQ5	Datenleitung A7
Datenleitung A4	ADQ6	27	28	GND	Masse
Masse	GND	29	30	ADQ7	Datenleitung A6
Datenleitung A11	ADQ8	31	32	GND	Masse
Masse	GND	33	34	ADQ9	Datenleitung A9
Datenleitung A8	ADQ10	35	36	GND	Masse
Masse	GND	37	38	ADQ11	Datenleitung A10
Data Strobe A1 -	ADQS#1	39	40	GND	Masse
Data Strobe A1 +	ADQS1	41	42	ADM1	Masse
Masse	GND	43	44	GND	Masse
Datenleitung A12	ADQ12	45	46	ADQ13	Datenleitung A13
Masse	GND	47	48	GND	Masse
Datenleitung A15	ADQ14	49	50	ADQ15	Datenleitung A14
Masse	GND	51	52	GND	Masse
Datenleitung A16	ADQ16	53	54	ADQ17	Datenleitung A17
Masse	GND	55	56	GND	Masse
Datenleitung A20	ADQ18	57	58	ADQ19	Datenleitung A19
Masse	GND	59	60	GND	Masse
Masse	ADM2	61	62	ADQS#2	Data Strobe A2 -
Masse	GND	63	64	ADQS2	Data Strobe A2 +
Datenleitung A18	ADQ20	65	66	GND	Masse
Masse	GND	67	68	ADQ21	Datenleitung A23
Datenleitung A22	ADQ22	69	70	GND	Masse
Masse	GND	71	72	ADQ23	Datenleitung A21
Datenleitung A25	ADQ24	73	74	GND	Masse
Masse	GND	75	76	ADQ25	Datenleitung A24
Datenleitung A26	ADQ26	77	78	GND	Masse
Masse	GND	79	80	ADQ27	Datenleitung A27
Data Strobe A3 -	ADQS#3	81	82	GND	Masse
Data Strobe A3 +	ADQS 3	83	84	ADM3	Masse
Masse	GND	85	86	GND	Masse
Datenleitung A31	DQ28	87	88	ADQ29	Datenleitung A29
Masse	GND	89	90	GND	Masse
Datenleitung A30	ADQ30	91	92	ADQ31	Datenleitung A28

Pinbelegung Speichersockel U601/U701					
Beschreibung	Signal	Pin1		Signal	Beschreibung
Masse	GND	93	94	GND	Masse
Datenleitung A32	ACB0	95	96	ACB1	Datenleitung A34
Masse	GND	97	98	GND	Masse
Datenleitung A33	ACB2	99	100	ADQS#4	Data Strobe A4 -
Masse	GND	101	102	ADQS4	Data Strobe A4 +
Datenleitung A35	ACB3	103	104	GND	Masse
Masse	GND	105	106	ACS#0	Control A0 -
Command A0	ACA0	107	108	ALERT#	Alert -
Command A1	ACA1	109	110	ACS#1	Control A1 -
Masse	GND	111	112	GND	Masse
Command A2	ACA2	113	114	ACA3	Command A3
Command A4	ACA4	115	116	ACA5	Command A5
Masse	GND	117	118	GND	Masse
Command A6	ACA6	119	120	ACA7	Command A7
Command A8	ACA8	121	122	ACA9	Command A9
Masse	GND	123	124	GND	Masse
Command A10	ACA10	125	126	ACA11	Command A11
Command A12	ACA12	127	128	RES2	Reserviert
Masse	GND	129	130	GND	Masse
Clock-Signal A0 +	ACK0	131	132	ACK1	Clock-Signal A1+
Clock-Signal A0 -	ACK#0	133	134	ACK#1	Clock-Signal A1-
Masse	GND	135	136	GND	Masse
Clock-Signal B0 +	BCK0	137	138	BCK1	Clock-Signal B1 +
Clock-Signal B0 -	BCK#0	139	140	BCK#1	Clock-Signal B1 -
Masse	GND	141	142	GND	Masse
Reserviert	RES3	143	144	BCA12	Command B12
Command B11	BCA11	145	146	BCA10	Command B10
Masse	GND	147	148	GND	Masse
Command B9	BCA9	149	150	BCA8	Command B8
Command B7	BCA7	151	152	BCA6	Command B6
Masse	GND	153	154	GND	Masse
Command B5	BCA5	155	156	BCA4	Command B4
Command B3	BCA3	157	158	BCA2	Command B2
Masse	GND	159	160	GND	Masse
Command 0 -	BCS#0	161	162	BCA1	Command B1
Reset	RESET	163	164	BCA0	Command B0
Command 1 -	BCS#1	165	166	GND	Masse
Masse	GND	167	168	BCB0	Datenleitung B35
Data Strobe B4 -	BDQS#4	169	170	GND	Masse
Data Strobe B4 +	BDQS4	171	172	BCB1	Datenleitung B34
Masse	GND	173	174	GND	Masse
Datenleitung B33	BCB3	175	176	BCB2	Datenleitung B32
Masse	GND	177	178	GND	Masse
Datenleitung B1	BDQ0	179	180	BDQ1	Datenleitung B0
Masse	GND	181	182	GND	Masse
Datenleitung B3	BDQ2	183	184	BDQ3	Datenleitung B2
Masse	GND	185	186	GND	Masse

Pinbelegung Speichersockel U601/U701					
Beschreibung	Signal	Pin1		Signal	Beschreibung
Masse	BDM0	187	188	BDQS#0	Data Strobe B0 -
Masse	GND	189	190	BDQS0	Data Strobe B0 +
Datenleitung B5	BDQ4	191	192	GND	Masse
Masse	GND	193	194	BDQ5	Datenleitung B4
Datenleitung B6	BDQ6	195	196	GND	Masse
Masse	GND	197	198	BDQ7	Datenleitung B7
Datenleitung B11	BDQ8	199	200	GND	Masse
Masse	GND	201	202	BDQ9	Datenleitung B10
Datenleitung B8	BDQ10	203	204	GND	Masse
Masse	GND	205	206	BDQ11	Datenleitung B9
Data Strobe B1 -	BDQS#1	207	208	GND	Masse
Data Strobe B1 +	BDQS1	209	210	BDM1	Masse
Masse	GND	211	212	GND	Masse
Datenleitung B13	BDQ12	213	214	BDQ13	Datenleitung B15
Masse	GND	215	216	GND	Masse
Datenleitung B14	BDQ14	217	218	BDQ15	Datenleitung B12
Masse	GND	219	220	GND	Masse
Datenleitung B17	BDQ16	221	222	BDQ17	Datenleitung B16
Masse	GND	223	224	GND	Masse
Datenleitung B19	BDQ18	225	226	BDQ19	Datenleitung B21
Masse	GND	227	228	GND	Masse
Masse	BDM2	229	230	BDQS#2	Data Strobe B2 -
Masse	GND	231	232	BDQS2	Data Strobe B2 +
Datenleitung B20	BDQ20	233	234	GND	Masse
Masse	GND	235	236	BDQ21	Datenleitung B22
Datenleitung B23	BDQ22	237	238	GND	Masse
Masse	GND	239	240	BDQ23	Datenleitung B18
Datenleitung B25	BDQ24	241	242	GND	Masse
Masse	GND	243	244	BDQ25	Datenleitung B24
Datenleitung B27	BDQ26	245	246	GND	Masse
Masse	GND	247	248	BDQ27	Datenleitung B26
Data Strobe B3 -	BDQS#3	249	250	GND	Masse
Data Strobe B3 +	BDQS3	251	252	BDM3	Masse
Masse	GND	253	254	GND	Masse
Datenleitung B28	BDQ28	255	256	BDQ29	Datenleitung B30
Masse	GND	257	258	GND	Masse
Datenleitung B31	BDQ30	259	260	BDQ31	Datenleitung B29
Masse	GND	261	262	GND	Masse

6.9 Spannungsversorgung (P1614/P1616)

Der Anschluss für die Spannungsversorgung ist als 2x12-poliger Standard-ATX-Buchse ("ATX24") realisiert. Dieser wird ergänzt durch eine 2x4-polige Gehäusebuchse, über die die CORE-IN-Spannung zu Verfügung gestellt werden muss.



Abb. 10: CB1076 2x12Pol-ATX Power

Pinbelegung 2x12 Pol-Buchse ATX-Power					
Beschreibung	Name	Pin		Name	Beschreibung
Versorgungsspannung 3,3 V	3,3V	1	13	3,3V	Versorgungsspannung 3,3 V
Versorgungsspannung 3,3 V	3,3V	2	14	-12V	Versorgungsspannung -12 V
Masse	GND	3	15	GND	Masse
Versorgungsspannung 5 V	VCC	4	16	PS_ON	Ein-/Aussignal
Masse	GND	5	17	GND	Masse
Versorgungsspannung 5 V	VCC	6	18	GND	Masse
Masse	GND	7	19	GND	Masse
ATX Powergood	PWR_ON	8	20	-5V	Versorgungsspannung -5 V
Standby 5 V	SVCC	9	21	VCC	Versorgungsspannung 5 V
Versorgungsspannung 12 V	12V	10	22	VCC	Versorgungsspannung 5 V
Versorgungsspannung 12 V	12V	11	23	VCC	Versorgungsspannung 5 V
Versorgungsspannung 3,3 V	3,3V	12	24	GND	Masse

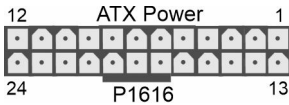

Abb. 11: CB1076 2x4Pol-MiniFit

Pinbelegung 2x4 Pol-Buchse MiniFit					
Beschreibung	Name	Pin		Name	Beschreibung
Masse	GND	1	5	COREIN	Versorgungsspannung 12 V
Masse	GND	2	6	COREIN	Versorgungsspannung 12 V
Masse	GND	3	7	COREIN	Versorgungsspannung 12 V
Masse	GND	4	8	COREIN	Versorgungsspannung 12 V

6.10 SATA (P1603 – P1608)

Zum Anschluss von SATA-Geräten stehen sechs SATA-Buchsen zur Verfügung. Sämtliche SATA-Kanäle unterstützen die Geschwindigkeitsmodi 1,5 Gbit/s, 3 Gbit/s und 6 Gbit/s.

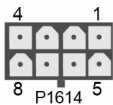

Abb. 12: CB1076 SATA-Buchsen

Pinbelegung SATA-Buchsen		
Pin	Name	Beschreibung
1	GND	Masse
2	SATATX	SATA Transmit +
3	SATATX#	SATA Transmit -
4	GND	Masse
5	SATARX#	SATA Receive -
6	SATARX	SATA Receive +
7	GND	Masse

6.11 System Port (P1610)

Das Board verfügt über eine 2x13-polige Standardstiftleiste für Schneidklemmtechnik im Rastermaß 2,54 mm über die die Signale für Powerbutton, Speaker, Reset und diverse Status-LEDs zur Verfügung gestellt werden. Dieser Stecker ist für Beckhoff codiert.

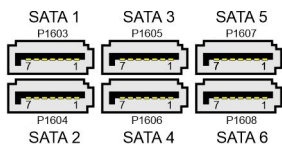

Abb. 13: CB1076 System Port

Pinbelegung Stecker System 1					
Beschreibung	Name	Pin		Name	Beschreibung
On/Suspend-Taste	PWRBTN#	A1	B1	GND	Masse
Masse	SVCC	A2	B2	N/C	Nicht verbunden
Nicht vorhanden	N/C	A3	B3	PWLED#	Power-LED
Masse	GND	A4	B4	N/C	Nicht verbunden
Versorgungsspannung 5 V	VCC	A5	B5	PWLED	Versorgungsspannung 3,3 V
Festplatten-LED	HDLED#	A6	B6	N/C	Nicht vorhanden
Versorgungsspannung 5 V	VCC	A7	B7	VCC	Versorgungsspannung 5 V
Nicht vorhanden	N/C	A8	B8	GND	Masse
Nicht verbunden	N/C	A9	B9	N/C	Nicht verbunden
Masse	GND	A10	B10	BEEP	Speaker
Nicht verbunden	N/C	A11	B11	N/C	Nicht vorhanden
Nicht verbunden	N/C	A12	B12	GND	Masse
Versorgungsspannung 5 V	VCC	A13	B13	RESET#	Reset

System Port 2

Das Board ist für einen weiteren 2x9-poligen System Port (P1612) vorbereitet und kann mit diesem bestückt werden.

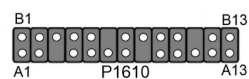
6.12 M.2 Key-M (P1700)

Das CB1076 ist mit einem M.2 Key-M-Sockel ausgestattet. Über diese Sockel werden PCIe®-Signale herausgeführt. NVMe™-Karten (M.2-2280) können betrieben werden. RAID 0, 1 und 5 werden unterstützt.



Abb. 14: CB1076 M.2M P1700

Pinbelegung M.2 Key-M (P1700):					
Beschreibung	Signal	Pin		Signal	Beschreibung
Masse	GND	1	2	3.3 V1	Standby Versorgungs- spannung S3,3 V
Masse	GND	3	4	3.3 V2	Standby Versorgungs- spannung S3,3 V
PCIe Lane 3 Receive -	PER3#	5	6	N/C	(nicht herausgeführt)
PCIe Lane 3 Receive +	PER3	7	8	N/C	(nicht herausgeführt)
Masse	GND	9	10	GPIO9 DAS DDS LED1	NVMELED-
PCIe Lane 3 Transmit -	PET3#	11	12	3.3 V3	Standby Versorgungs- spannung S3,3 V
PCIe Lane 3 Transmit +	PET3	13	14	3.3 V4	Standby- Versorgungs- spannung S3,3 V
Masse	GND	15	16	3.3 V5	Standby- Versorgungs- spannung S3,3 V
PCIe Lane 2 Receive -	PER2#	17	18	3.3 V6	Standby- Versorgungs- spannung S3,3 V
PCIe Lane 2 Receive +	PER2	19	20	N/C	(nicht herausgeführt)
Masse	GND	21	22	N/C	(nicht herausgeführt)
PCIe Lane 2 Transmit -	PET2#	23	24	N/C	(nicht herausgeführt)
PCIe Lane 2 Transmit +	PET2	25	26	N/C	(nicht herausgeführt)
Masse	GND	27	28	N/C	(nicht herausgeführt)
PCIe Lane 1 Receive -	PER1#	29	30	N/C	(nicht herausgeführt)
PCIe Lane 1 Receive	PER1	31	32	N/C	(nicht herausgeführt)
Masse	GND	33	34	N/C	(nicht herausgeführt)
PCIe Lane 1 Transmit -	PET1#	35	36	N/C	(nicht herausgeführt)
PCIe Lane 1 Transmit +	PET1	37	38	DEVSLP	(nicht herausgeführt)
Masse	GND	39	40	N/C	(nicht herausgeführt)
PCIe Lane 0 Receive +	PER0# SATAB	41	42	N/C	(nicht herausgeführt)
PCIe Lane 0 Receive -	PER0 SATAB#	43	44	N/C	(nicht herausgeführt)
Masse	GND	45	46	N/C	(nicht herausgeführt)
PCIe Lane 0 Transmit -	PET0# SATAA#	47	48	N/C	(nicht herausgeführt)
PCIe Lane 0 Transmit +	PET0 SATAA	49	50	PRST#	PCIe Reset active low

Pinbelegung M.2 Key-M (P1700):					
Beschreibung	Signal	Pin		Signal	Beschreibung
Masse	GND	51	52	CLKREQ#	PCIe Clock Enable active low
PCIe Lane Reference Clock -	REFCLK#	53	54	PEWAKE#	Link Reactivation active low
PCIe Lane Reference Clock +	REFCLK	55	56	N/C	(nicht herausgeführt)
Masse	GND	57	58	N/C	(nicht herausgeführt)
(nicht herausgeführt)	N/C	59	60	N/C	(nicht herausgeführt)
(nicht herausgeführt)	N/C	61	62	N/C	(nicht herausgeführt)
(nicht herausgeführt)	N/C	63	64	N/C	(nicht herausgeführt)
(nicht herausgeführt)	N/C	65	66	N/C	(nicht herausgeführt)
(nicht herausgeführt)	N/C	67	68	SUSCLK	Systemclock
Konfigurationspin	CFG_PClE/ SATA	69	70	3.3 V	Standby-Versorgungsspannung S3,3 V
Masse	GND	71	72	3.3 V	Standby-Versorgungsspannung S3,3 V
Masse	GND	73	74	3.3 V	Standby-Versorgungsspannung S3,3 V
Masse	GND	75			

6.13 USB3.1 Gen2 Typ A (P1613)

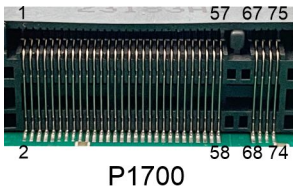
Über diese interne USB-Schnittstelle wird USB3.0 zur Verfügung gestellt.

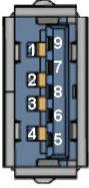

P1613

Abb. 15: CB 1076 USB 3.1 Typ A

Pinbelegung interner USB 3.1-Stecker		
Pin	Name	Beschreibung
1	VCC	5V für USB
2	USB-D#	Minus-Datenkanal USB
3	USB-D	Plus-Datenkanal USB
4	GND1	Masse
5	SSRX-	SuperSpeed Receiver -
6	SSRX+	SuperSpeed Receiver +
7	GND2	Masse
8	SSTX-	SuperSpeed Transmitter -
9	SSTX+	SuperSpeed Transmitter +

6.14 GPIO (P1615)

Das Board verfügt über eine General Purpose Input/Output-Schnittstelle, die über einen 2x10-poligen Wannenstecker die Signale herausführt. Durch entsprechende Programmierung des zugehörigen Chips können hier in sehr flexibler Weise I/O-Funktionen angelegt werden. Erkundigen Sie sich bei Ihrem Distributor nach entsprechender Software-Unterstützung.



Abb. 16: CB1076 GPIO-Buchse

Pinbelegung GPIO-Stecker					
Beschreibung	Name	Pin		Name	Beschreibung
Versorgungsspannung 5 V	VCC	1	11	VCC	Versorgungsspannung 5 V
GP Input/Output 0	GPIO0	2	12	N/C	Nicht verbunden
GP Input/Output 1	GPIO1	3	13	N/C	Nicht verbunden
GP Input/Output 2	GPIO2	4	14	N/C	Nicht verbunden
GP Input/Output 3	GPIO3	5	15	N/C	Nicht verbunden
GP Input/Output 4	GPIO4	6	16	N/C	Nicht verbunden
GP Input/Output 5	GPIO5	7	17	N/C	Nicht verbunden
GP Input/Output 6	GPIO6	8	18	N/C	Nicht verbunden
GP Input/Output 7	GPIO7	9	19	N/C	Nicht verbunden
Masse	GND	10	20	GND	Masse

6.15 SMB/I²C (P1600)

Die Baugruppe kann mit anderen Schaltelementen über das SMBus- oder das I²C-Protokoll kommunizieren. Die Anschlüsse hierfür sind in einer 2x5-poligen Wannenchse realisiert. Die SMBus-Signale werden durch den Chipsatz verarbeitet, die I²C-Signale durch den SIO-Chip.

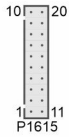

Abb. 17: CB1076 SMB-I2C-Buchse

Pinbelegung SMB/I ² C-Stecker					
Beschreibung	Name	Pin		Name	Beschreibung
Versorgungsspannung 3,3 V	3,3V	1	6	GND	Masse
SMBus Clock	SMBCLK	2	7	SMBDAT	SMBus Data
SMBus Alarm	SMBALERT#	3	8	SVCC	Standby-Versorgung 5 V
I ² C-Bus Clock	I2CLK	4	9	I2DAT	I ² C-Bus Data
Versorgungsspannung 5 V	VCC	5	10	GND	Masse

6.16 PCIe x4 (P1205/P1206/P1204/P1201)

Auf dem CB1076-Board stehen vier Steckplätze für PCI-Express-x4-Erweiterungskarten zur Verfügung. In diesen können auch x1-Erweiterungskarten verwendet werden.

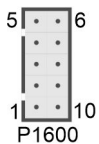

Abb. 18: CB1076 PCIe-x4-Buchse

Pinbelegung PCI-Express x4-Buchse					
Beschreibung	Name	Pin		Name	Beschreibung
Hot Plug Detect 1	PRSNT1	A1	B1	12V	Versorgungsspannung 12 V
Versorgungsspannung 12 V	12V	A2	B2	12V	Versorgungsspannung 12 V
Versorgungsspannung 12 V	12V	A3	B3	RSVD	Nicht verbunden
Masse	GND	A4	B4	GND	Masse
Nicht verbunden	TCK	A5	B5	SMBCLK	SMBus Clock PCIe
Nicht verbunden	TDI	A6	B6	SMBDAT	SMBus Data PCIe
Nicht verbunden	TDO	A7	B7	GND	Masse
Nicht verbunden	TMS	A8	B8	3,3V	Versorgungsspannung 3,3 V
Versorgungsspannung 3,3 V	3,3V	A9	B9	TRST	Nicht verbunden
Versorgungsspannung 3,3 V	3,3V	A10	B10	S3,3V	Standby-Spannung 3,3 V
PCIe Reset -	PERST#	A11	B11	WAKE#	Link Reactivation -
Masse	GND	A12	B12	RSVD	Nicht verbunden
Reference Clock +	REFCLK	A13	B13	GND	Masse
Reference Clock -	REFCLK#	A14	B14	PET0	Transmit Lane 0 +
Masse	GND	A15	B15	PET0#	Transmit Lane 0 -
Receive Lane 0 +	PER0	A16	B16	GND	Masse
Receive Lane 0 -	PER0#	A17	B17	PRSNT2#	PCIe Clock Enable -
Masse	GND	A18	B18	GND	Masse
Nicht verbunden	RSVD	A19	B19	PET1	Transmit Lane 1 +
Masse	GND	A20	B20	PET1#	Transmit Lane 1 -
Receive Lane 1 +	PER1	A21	B21	GND	Masse
Receive Lane 1 -	PER1#	A22	B22	GND	Masse
Masse	GND	A23	B23	PET2	Transmit Lane 2 +
Masse	GND	A24	B24	PET2#	Transmit Lane 2 -
Receive Lane 2 +	PER2	A25	B25	GND	Masse
Receive Lane 2 -	PER2#	A26	B26	GND	Masse
Masse	GND	A27	B27	PET3	Transmit Lane 3 +
Masse	GND	A28	B28	PET3#	Transmit Lane 3 -
Receive Lane 3 +	PER3	A29	B29	GND	Masse
Receive Lane 3 -	PER3#	A30	B30	RSVD	Nicht verbunden
Masse	GND	A31	B31	PRSNT2#	Hot Plug Detect 1
Nicht verbunden	RSVD	A32	B32	GND	Masse

6.17 PCIe x1 (P1200/P1203)

Auf dem CB1076-Board stehen zwei Steckplätze für PCI-Express-x1-Erweiterungskarten zur Verfügung.

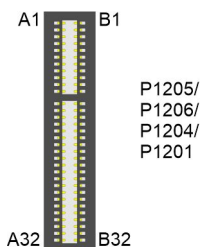

Abb. 19: CB1076 PCIe-x1-Buchse

HINWEIS

Pinbelegung beachten

Beachten Sie bei der folgenden Pinbelegung-Tabelle, dass es bei bestimmten Signalen notwendigerweise Unterschiede zwischen den verschiedenen PCIe-x1-Steckern auf dem Board gibt. Dies betrifft die Clock-Signale (A13, A14), die Receive-Signale (A16, A17) und die Transmit-Signale (B14, B15).

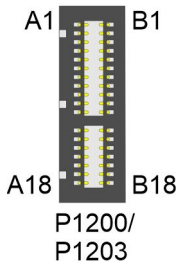
Pinbelegung PCI-Express-x1-Buchse					
Beschreibung	Name	Pin		Name	Beschreibung
Hot Plug Detect 1	PRSNT1#	A1	B1	12V	Versorgungsspannung 12 V
Versorgungsspannung 12 V	12V	A2	B2	12V	Versorgungsspannung 12 V
Versorgungsspannung 12 V	12V	A3	B3	RSVD	Nicht verbunden t
Masse	GND	A4	B4	GND	Masse
Nicht verbunden	TCK	A5	B5	SMBCLK	SMBus Clock PCIe
Nicht verbunden	TDI	A6	B6	SMBDAT	SMBus Data PCIe
Nicht verbunden	TDO	A7	B7	GND	Masse
Nicht verbunden	TMS	A8	B8	3,3V	Versorgungsspannung 3,3 V
Versorgungsspannung 3,3 V	3,3V	A9	B9	TRST	Nicht verbunden
Versorgungsspannung 3,3 V	3,3V	A10	B10	S3,3V	Standby-Spannung 3,3 V
PCIe Reset -	PERST#	A11	B11	PEWAKE#	Link Reactivation
Masse	GND	A12	B12	RSVD	Nicht verbunden
Reference Clock +	REFCLK	A13	B13	GND	Masse
Reference Clock -	REFCLK#	A14	B14	PET0	Transmit Lane 0 +
Masse	GND	A15	B15	PET0#	Transmit Lane 0 -
Receive Lane 0 +	PER0	A16	B16	GND	Masse
Receive Lane 0 -	PER0#	A17	B17	PRSNT2#	Hot Plug Detect 1
Masse	GND	A18	B18	GND	Masse

6.18 PCIe x16 (P1202)

Auf dem CB1076-Board steht ein Steckplatz für eine PCIe-x16-Karte zur Verfügung. PCIe-x16-Grafikkarten, x1- oder x4-Erweiterungskarten können in diesem Steckplatz eingesetzt werden.



Abb. 20: CB1076 PCIe-x16-Buchse

Pinbelegung PCI-Express-x16-Buchse					
Beschreibung	Name	Pin		Name	Beschreibung
Hot Plug Detect 1 -	PRST1#	A1	B1	12V	Versorgungsspannung 12 V
Versorgungsspannung 12 V	12V	A2	B2	12V	Versorgungsspannung 12 V
Versorgungsspannung 12 V	12V	A3	B3	RSVD	Reserviert
Masse	GND	A4	B4	GND	Masse
Test Clock	TCK	A5	B5	SMBCLK	SMBus Clock PCIe
Nicht verbunden	TDI	A6	B6	SMBDAT	SMBus Data PCIe
Nicht verbunden	TDO	A7	B7	GND	Masse
Nicht verbunden	TMS	A8	B8	3,3V	Versorgungsspannung 3,3 V
Versorgungsspannung 3,3 V	3,3V	A9	B9	TRST	Nicht verbunden
Versorgungsspannung 3,3 V	3,3V	A10	B10	S3,3V	Standby-Spannung 3,3 V
PCIe Reset	PERST#	A11	B11	WAKE#	Link Reactivation -
Masse	GND	A12	B12	RSVD	Nicht verbunden
Reference Clock +	REFCLK	A13	B13	GND	Masse
Reference Clock -	REFCLK#	A14	B14	PET0	Transmit Lane 0 +
Masse	GND	A15	B15	PET0#	Transmit Lane 0 -
Receive Lane 0 +	PER0	A16	B16	GND	Masse
Receive Lane 0 -	PER0#	A17	B17	PRST2#	Hot Plug Detect 2 -
Masse	GND	A18	B18	GND	Masse
Nicht verbunden	RSVD	A19	B19	PET1	Transmit Lane 1 +
Masse	GND	A20	B20	PET1#	Transmit Lane 1 -
Receive Lane 1 +	PER1	A21	B21	GND	Masse
Receive Lane 1 -	PER1#	A22	B22	GND	Masse
Masse	GND	A23	B23	PET2	Transmit Lane 2 +
Masse	GND	A24	B24	PET2#	Transmit Lane 2 -
Receive Lane 2 +	PER2	A25	B25	GND	Masse
Receive Lane 2 -	PER2#	A26	B26	GND	Masse
Masse	GND	A27	B27	PET3	Transmit Lane 3 +
Masse	GND	A28	B28	PET3#	Transmit Lane 3 -
Receive Lane 3 +	PER3	A29	B29	GND	Masse
Receive Lane 3 -	PER3#	A30	B30	RSVD	Nicht verbunden
Masse	GND	A31	B31	PRST2#	Hot Plug Detect 2 -
Nicht verbunden	RSVD	A32	B32	GND	Masse
Nicht verbunden	RSVD	A33	B33	PET4	Transmit Lane 4 +
Masse	GND	A34	B34	PET4#	Transmit Lane 4 -
Receive Lane 4 +	PER4	A35	B35	GND	Masse
Receive Lane 4 -	PER4#	A36	B36	GND	Masse
Masse	GND	A37	B37	PET5	Transmit Lane 5 +
Masse	GND	A38	B38	PET5#	Transmit Lane 5 -
Receive Lane 5 +	PER5	A39	B39	GND	Masse
Receive Lane 5 -	PER5#	A40	B40	GND	Masse
Masse	GND	A41	B41	PET6	Transmit Lane 6 +
Masse	GND	A42	B42	PET6#	Transmit Lane 6 -
Receive Lane 6 +	PER6	A43	B43	GND	Masse
Receive Lane 6 -	PER6#	A44	B44	GND	Masse
Masse	GND	A45	B45	PET7	Transmit Lane 7 +
Masse	GND	A46	B46	PET7#	Transmit Lane 7 -
Receive Lane 7 +	PER7	A47	B47	GND	Masse

Pinbelegung PCI-Express-x16-Buchse					
Beschreibung	Name	Pin		Name	Beschreibung
Receive Lane 7 -	PER7#	A48	B48	PRSNT2#	Hot Plug Detect 2 -
Masse	GND	A49	B49	GND	Masse
Nicht verbunden	N/C	A50	B50	PET8	Transmit Lane 8 +
Masse	GND	A51	B51	PET8#	Transmit Lane 8 -
Receive Lane 8 +	PER8	A52	B52	GND	Masse
Receive Lane 8 -	PER8#	A53	B53	GND	Masse
Masse	GND	A54	B54	PET9	Transmit Lane 9 +
Masse	GND	A55	B55	PET9#	Transmit Lane 9 -
Receive Lane 9 +	PER9	A56	B56	GND	Masse
Receive Lane 9 -	PER9#	A57	B57	GND	Masse
Masse	GND	A58	B58	PET10	Transmit Lane 10 +
Masse	GND	A59	B59	PET10#	Transmit Lane 10 -
Receive Lane 10 +	PER10	A60	B60	GND	Masse
Receive Lane 10 -	PER10#	A61	B61	GND	Masse
Masse	GND	A62	B62	PET11	Transmit Lane 11 +
Masse	GND	A63	B63	PET11#	Transmit Lane 11 -
Receive Lane 11 +	PER11	A64	B64	GND	Masse
Receive Lane 11 -	PER11#	A65	B65	GND	Masse
Masse	GND	A66	B66	PET12	Transmit Lane 12 +
Masse	GND	A67	B67	PET12#	Transmit Lane 12 -
Receive Lane 12 +	PER12	A68	B68	GND	Masse
Receive Lane 12 -	PER12#	A69	B69	GND	Masse
Masse	GND	A70	B70	PET13	Transmit Lane 13 +
Masse	GND	A71	B71	PET13#	Transmit Lane 13 -
Receive Lane 13+	PER13	A72	B72	GND	Masse
Receive Lane 13-	PER13#	A73	B73	GND	Masse
Masse	GND	A74	B74	PET14	Transmit Lane 14 +
Masse	GND	A75	B75	PET14#	Transmit Lane 14 -
Receive Lane 14 +	PER14	A76	B76	GND	Masse
Receive Lane 14 -	PER14#	A77	B77	GND	Masse
Masse	GND	A78	B78	PET15	Transmit Lane 15 +
Masse	GND	A79	B79	PET15#	Transmit Lane 15 -
Receive Lane 15 +	PER15	A80	B80	GND	Masse
Receive Lane 15 -	PER15#	A81	B81	DDAT- PRSNT	Reserviert
Masse	GND	A82	B82	RSVD	Nicht verbunden

6.19 LAN 2,5 Gbit und USB 3.1Gen2 (P1402/P1401/P1400)

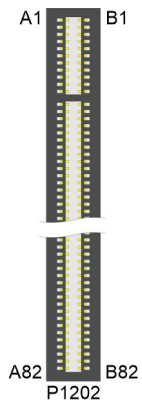
USB- und LAN-Buchse sind als Kombi-Buchsen realisiert, die jeweils zwei USB- und einen LAN-Port zur Verfügung stellen. Auf diese Weise werden bei allen Boardvarianten sechs USB-Kanäle und drei LAN-Anschlüsse herausgeführt.

Alle USB-Kanäle unterstützen die Spezifikation 3.1 Gen2.

Durch das BIOS können alle notwendigen Einstellungen für USB durchgeführt werden. Beachten Sie, dass die Funktionalität "USB-Maus und Tastatur" des BIOS-Setup nur benötigt wird, wenn das Betriebssystem keine USB-Unterstützung bietet. Wählen Sie diese Funktion nicht für Einstellungen im Setup und zum Booten von Windows mit einer angeschlossenen USB-Maus und Tastatur weil dies zu erheblichen Leistungseinschränkungen führen würde.

Die einzelnen USB-Schnittstellen können bis zu 900mA Strom liefern und sind elektronisch abgesichert.

An die LAN-Ports P1401 A und P1402 A können Sie 10BaseT-, 100BaseT-, 1000BaseT und 2500BaseT -kompatible Netzwerkkomponenten anschließen. Die erforderliche Geschwindigkeit wird automatisch gewählt. TSN, Auto-Cross und Auto-Negotiate stehen ebenso zur Verfügung wie PXE- und RPL-Funktionalität. Controller ist Intel®'s i219 für Lan1 1Gbit mit WOL (P1400 A) und i226 für LAN2 und 3, 2.5Gbit (P1401 A und P1402 A).



Abb. 21: CB1076 LAN-USB-Buchse

Pinbelegung LAN-Buchse i219 (P1400)		
Pin	Name	Beschreibung
1	LAN10	LAN Leitung 1 +
2	LAN10#	LAN Leitung 1 -
3	LAN11	LAN Leitung 2 +
4	LAN11#	LAN Leitung 2 -
5	LAN12	LAN Leitung 3 +
6	LAN12#	LAN Leitung 3 -
7	LAN13	LAN Leitung 4 +
8	LAN13#	LAN Leitung 4 -

Pinbelegung LAN-Buchse i226 (P1401/P1402)		
Pin	Name	Beschreibung
1	LAN20/30	LAN Leitung 1 +
2	LAN20#/30#	LAN Leitung 1 -
3	LAN21/31	LAN Leitung 2 +
4	LAN21#/31#	LAN Leitung 2 -
5	LAN22/32	LAN Leitung 3 +
6	LAN22#/32	LAN Leitung 3 -
7	LAN23//33	LAN Leitung 4 +
8	LAN23#/33#	LAN Leitung 4 -

i Echtzeitanwendungen

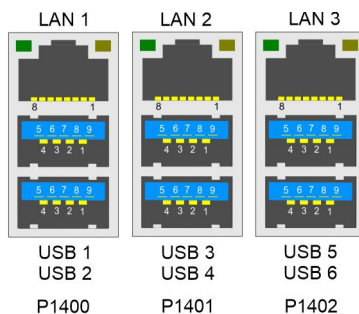
Der über PCIe angebundene Ethernet-Port ist in der Regel für Zyklus-Zeiten ≤ 1 ms und für Distributed-Clock-Anwendungen bei EtherCAT geeignet.

Der im Chipsatz integrierte Ethernet-Port ist in der Regel für Real-Time-Ethernet-Anwendungen mit Zyklus-Zeiten > 1 ms (ohne Distributed-Clocks) geeignet.

Pinbelegung USB3.1-Gen2-Buchse (P1400/P1401/P1402):		
Pin	Signal	Beschreibung
1	VCC	Versorgungsspannung 5 V
2	D-	Daten - (USB 3.1)
3	D+	Daten + (USB 3.1)
4	GND	Masse
5	SSRX-	Receive Leitung - (USB 3.1)
6	SSRX+	Receive Leitung + (USB 3.1)
7	GND	Masse
8	SSTX-	Transmit Leitung - (USB 3.1)
9	SSTX+	Transmit Leitung + (USB 3.1)

6.20 DVI-D (P1500A/B)

Das CB1076 verfügt über zwei DVI-D-Buchsen in einem Kombibauteil (Foxconn QH11121-DBDF-4F). An beiden Buchsen können Sie digitale DVI- oder HDMI-Displays anschließen. Analoge Signale liegen an diesem Anschluss nicht an. Die CPU-Grafik unterstützt maximal drei unabhängige Displays.



Abb. 22: CB1076 DVI-D-Buchse

Pinbelegung DVI-D:		
Pin	Name	Beschreibung
1	TMDSDAT2#	DVI-Daten 2 -
2	TMDSDAT2	DVI-Daten 2 +
3	GND	Masse
4	N/C	Reserviert
5	N/C	Reserviert
6	DDC CLK	DDC Clock (DVI/VGA)
7	DDC DAT	DDC Data (DVI/VGA)
8	N/C	Reserviert
9	TMDSDAT1#	DVI-Daten 1 -
10	TMDSDAT1	DVI-Daten 1 +
11	GND	Masse
12	N/C	Reserviert
13	N/C	Reserviert
14	VCC	Versorgungsspannung 5 V
15	GND	Masse
16	HP_DETECT	Hot Plug Detect
17	TMDSDAT0#	DVI-Daten 0 -
18	TMDSDAT0	DVI-Daten 0 +
19	GND	Masse
20	N/C	Reserviert
21	N/C	Reserviert
22	GND	Masse
23	TMDS CLK	DVI-Clock
24	TMDS CLK#	DVI-Clock

6.21 Serielle Schnittstelle COM1 (P1403)

Die serielle Schnittstelle COM1 ist über eine 9-polige Standard-DSUB-Buchse herausgeführt. Die Signale entsprechen der RS232-Norm.

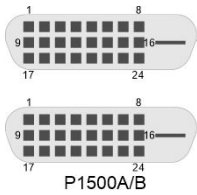
Die Port-Adresse und den benutzten Interrupt stellen Sie mit Hilfe des BIOS-Setup ein.



Abb. 23: CB1076 COM1-Buchse

Pinbelegung COM1:					
Beschreibung	Name	Pin		Name	Beschreibung
Data Carrier Detect	DCD#	1	6	DSR#	Data Set Ready
Receive Data	RXD	2	7	RTS#	Request to Send
Transmit Data	TXD	3	8	CTS#	Clear to Send
Data Terminal Ready	DTR#	4	9	RI#	Ring Indicator
Masse	GND	5			

6.22 Display Port (P1501)

Für Geräte mit DisplayPort-Anschluss steht eine entsprechende Standard-Buchse (Foxconn 3VC11203-D7AB-4H) zur Verfügung.

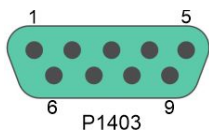
Die Schnittstelle stellt zusätzlich HDMI/DVI-Signale zur Verfügung, die mit Hilfe eines Adapters genutzt werden können. Bitte wenden Sie sich an Ihren Distributor bezüglich passender Adapter.



Abb. 24: CB1076 Display Port

Pinbelegung DisplayPort					
Beschreibung	Signal	Pin		Signal	Beschreibung
Display Port Lane 0 +	L0	1	2	GND	Masse
Display Port Lane 0 -	L#0	3	4	L1	Display Port Lane 1 +
Masse	GND	5	6	L#1	Display Port Lane 1 -
Display Port Lane 2 +	L2	7	8	GND	Masse
Display Port Lane 2 -	L#2	9	10	L3	Display Port Lane 3 +
Masse	GND	11	12	L#3	Display Port Lane 3 -
DP / HDMI -	HDMI#	13	14	GND	Masse
Auxiliary plus	AUX	15	16	GND	Masse
Auxiliary minus	AUX#	17	18	HPD	Hot Plug Detect
Masse	GND	19	20	3.3 V	Versorgungsspannung 3.3 V

7 BIOS

7.1 Benutzung des Setups

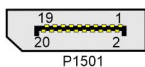
Innerhalb der einzelnen Setup-Seiten können jederzeit mit F2 („Previous Values“) die zuletzt abgespeicherten Einstellungen wieder hergestellt werden. Mit F3 („Optimized Defaults“) werden werkseitig festgelegte Standardwerte geladen. F2/F3 und auch F4 („Save & Reset“) laden bzw. sichern immer den kompletten Satz an Einstellungen.

Ein „▶“-Zeichen vor dem Menüpunkt bedeutet, dass ein Untermenü vorhanden ist. Die Navigation von einem Menüpunkt zum anderen erfolgt mit Hilfe der Pfeiltasten, wobei mit der Enter-Taste der entsprechende Menüpunkt ausgewählt wird, was dann z. B. den Aufruf eines Untermenüs oder eines Auswahldialogs bewirkt.

Zu jeder einzelnen Setup-Option wird oben rechts ein Hilfetext angezeigt, der in vielen Fällen nützliche Informationen zur Bedeutung der Option, zu erlaubten Werten usw., enthält.

● Hinweis zur Setup-Dokumentation

i Das BIOS wird regelmäßig weiterentwickelt, so dass die verfügbaren Setup-Optionen sich jederzeit und ohne gesonderte Mitteilung ändern können. Dadurch kann es zu Abweichungen kommen zwischen den tatsächlich vorhandenen Optionen und denen, die nachfolgend beschrieben werden. Zu beachten ist außerdem, dass die in den Setup-Menüs im Folgenden gezeigten Einstellungen nicht notwendigerweise die empfohlenen oder die Default-Einstellungen sind. Welche Einstellungen gewählt werden müssen, hängt jeweils vom Anwendungsszenario ab, in dem das Board betrieben wird.

BIOS-Eintrag	Option
Board Information	
Board	Keine
Revision	Keine
Bios Version	Keine
Processor Information	
Name	Keine
Type	Keine
Speed	Keine
ID	Keine
Stepping	Keine
Number of Efficient-cores	Keine
Number of Performance-cores	Keine
Microcode Revision	Keine
GT Info	Keine
IGFX GOP Version	Keine
Memory RC Version	Keine
Total Memory	Keine
Memory Frequency	Keine
PCH Information	
Name	Keine
Stepping	Keine
ME FW Version	Keine
System Date	Hier ändern Sie das Systemdatum.
System Time	Hier ändern Sie die Systemzeit.

7.3 Advanced Menu

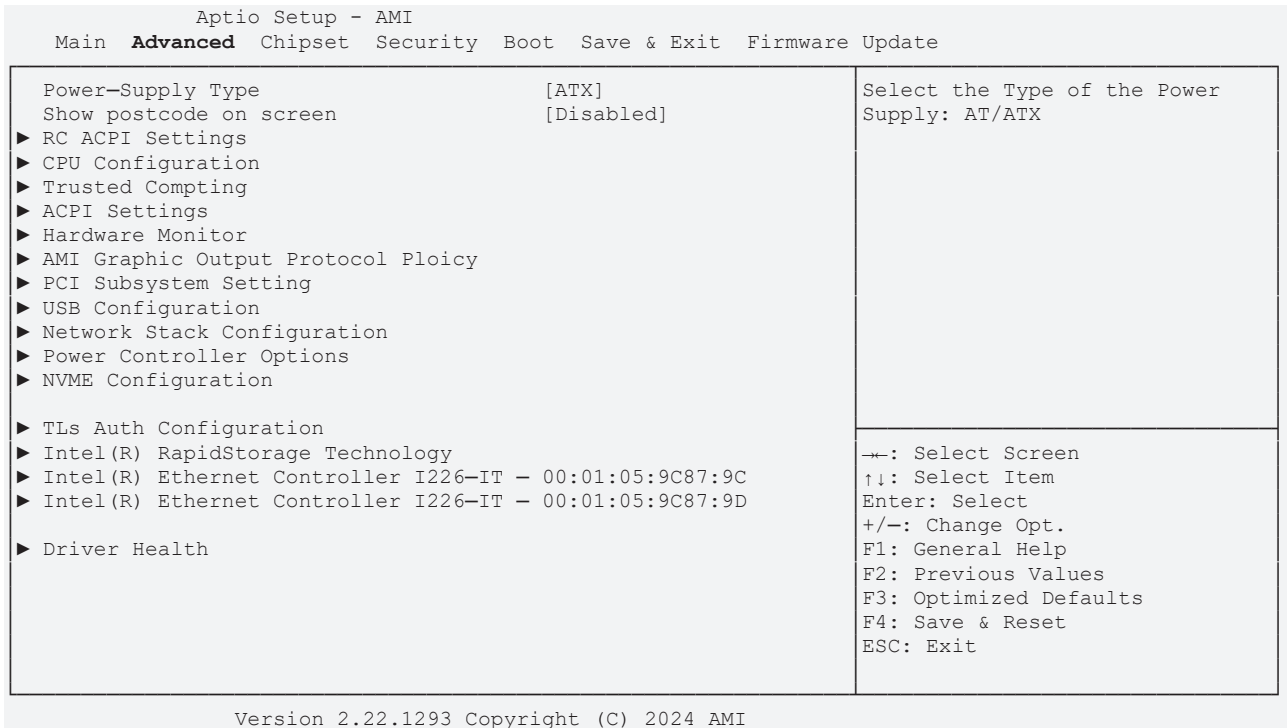

BIOS-Eintrag	Option
Power-Supply Type	ATX / AT
Show Postcode on screen	Disabled / Enabled
RC ACPI Settings	Untermenü siehe: RC ACPI Settings [▶ 49]
CPU Configuration	Untermenü siehe: CPU Configuration [▶ 50]
Trusted Computing	Untermenü siehe: Trusted Computing [▶ 54]
ACPI Settings	Untermenü siehe: ACPI Settings Disabled [▶ 55]
Hardware Monitor	Untermenü siehe: Hardware Monitor [▶ 56]
AMI Graphic Output Protocol Policy	Untermenü siehe: AMI Graphic Output Protocol Policy [▶ 57]
PCI Subsystem Settings	Untermenü siehe: PCI Subsystem Settings [▶ 57]
USB Konfiguration	Untermenü siehe: USB Configuration [▶ 58]
Network Stack Configuration	Untermenü siehe: Network Stack Configuration enabled [▶ 59]
Power Controller Options	Untermenü siehe: Power Controller Options [▶ 60]
NVMe Configuration	Untermenü siehe: NVMe Configuration [▶ 61]
Tls Auth Configuration	Untermenü siehe: Tls Auth Configuration [▶ 62]
Intel® Rapid Storage Technology	Untermenü siehe: Intel Rapid Storage Technology [▶ 64]
Intel® Ethernet Controller I226-IT – 00:01:05:9C:87:9C	Untermenü siehe: Intel Ethernet Controller I226-IT [▶ 65]
Intel® Ethernet Controller I226-IT – 00:01:05:9C:87:9D	Untermenü siehe: Intel Ethernet Controller I226-IT [▶ 66]
Driver Health	Keine

7.3.1 RC ACPI Settings

Aptio Setup - AMI
Advanced

RC ACPI Settings PTID Support [Enabled] PECI Access Method [Direct I/O] Native PCIE Enable [Enabled] BDAT ACPI Table Support [Disabled] ACPI Debug [Disabled] PUIS Enable [Disabled] PCI Delay Optimization [Disabled] MSI enabled [Enabled]	PTID Support will be loaded if enabled. →: Select Screen ↑↓: Select Item +/-: Change Opt. F1: General Help F2: Previous Values F3: Optimized Defaults F4: Save & Reset ESC: Exit
--	--

Version 2.22.1293 Copyright (C) 2024 AMI

BIOS-Eintrag	Optionen
RC ACPI Settings	
PTID Support	Enabled / Disabled
PECI Access Method	Direct I/O / ACPI
Native PCIE Enable	Enabled / Disabled
BDAT ACPI Table Support	Disabled / Enabled
ACPI Debug	Disabled / Enabled
PUIS Enable	Keine
PCI Delay Optimization	Disabled / Enabled
MSI enabled	Enabled / Disabled

BIOS-Eintrag	Optionen
CPU Configuration	
Efficient-core Information	Untermenü siehe:
Performance-core Information	Untermenü siehe: Efficient-core Information [► 52]
ID	Keine
Brand String	Keine
VMX	Keine
SMX/TXT	Keine
C6DRAM	Enabled / Disabled
CPU Flex Ratio Override	Disabled / Enabled
CPU Flex Ratio Settings	Keine
Hardware Prefetcher	Enabled / Disabled
Adjacent Cache Line Prefetch	Enabled / Disabled
Intel (VMX) Virtualization Technology	Enabled / Disabled
PECI	Enabled / Disabled
AVX	Enabled / Disabled
Active Performance-cores	All / 1 / 2 / 3
Efficient Performance-cores	All / 1 / 2 / 3
Hyper-Threading	Disabled / Enabled
BIST	Disabled / Enabled
AP threads Idle Manner	MWAIT Loop / HALT Loop / Run Loop
AES	Enabled / Disabled
MachineCheck	Enabled / Disabled
Intel Trusted Execution Technology	Disabled / Enabled
Alias Check Request	Disabled / Enabled
DPR Memory Size (MB)	Keine
Reset Aux Comment	Keine
CPU SMM Enhancement	Untermenü siehe: CPU SMM Enhancement [► 53]
Total Memory Encryption	Disabled / Enabled

7.3.2.1 Efficient-core Information

Aptio Setup - AMI
Advanced

Efficient-core Information L1 Data Cache 32 KB x 8 L1 Instruction 64 KB x 8 L2 Cache 4096 KB x 2 L3 Cache 30 MB	←: Select Screen ↑↓: Select Item Enter: Select +/-: Change Opt. F1: General Help F2: Previous Values F3: Optimized Defaults F4: Save & Reset ESC: Exit
---	--

Version 2.22.1293 Copyright (C) 2024 AMI

BIOS-Eintrag	Optionen
Efficient-core Information	
L1 Data Cache	Keine
L1 Instruction	Keine
L2 Cache	Keine
L3 Cache	Keine

7.3.2.2 Performance-core Information

Aptio Setup - AMI
Advanced

Performance-core Information L1 Data Cache 48 KB x 8 L1 Instruction 32 KB x 8 L2 Cache 2048 KB x 8 L3 Cache 30 MB	←: Select Screen ↑↓: Select Item Enter: Select +/-: Change Opt. F1: General Help F2: Previous Values F3: Optimized Defaults F4: Save & Reset ESC: Exit
---	--

Version 2.22.1293 Copyright (C) 2024 AMI

BIOS-Eintrag	Optionen
Performance-core Information	
L1 Data Cache	Keine
L1 Instruction	Keine
L2 Cache	Keine
L3 Cache	Keine

7.3.2.3 CPU SMM Enhancement

Aptio Setup - AMI
Advanced

CPU SMM enhancement SMM Use Delay Indication [Enabled] SMM Use Block Indication [Enabled] SMM Use en-US Indication [Enabled]	Enable/Disable usage of SMM_DELAYED MSR for MP sync in SMI ←: Select Screen ↑↓: Select Item Enter: Select +/-: Change Opt. F1: General Help F2: Previous Values F3: Optimized Defaults F4: Save & Reset ESC: Exit
---	--

Version 2.22.1293 Copyright (C) 2024 AMI

BIOS-Eintrag	Optionen
CPU SMM Enhancement	
SMM Use Delay Indication	Enabled / Disabled
SMM Use Block Indication	Enabled / Disabled
SMM Use en-US Indication	Enabled / Disabled

7.3.3 Trusted Computing

Aptio Setup - AMI
Advanced

<pre> TPM 2.0 Device Found Firmware Version: 600.18 Vendor: INTC Security Device Support [Enable] Active PCR banks SHA256 Available PCR banks SHA256, SHA384, SM3 SHA256 PCR Bank [Enabled] SHA384 PCR Bank [Disabled] SM3_256 PCR Bank [Disabled] Pending operation [None] Platform Hierarchy [Enabled] Storage Hierarchy [Enabled] Endorsement Hierarchy [Enabled] Physical Presence Spec Version [1.3] TPM 2.0 InterfaceType [CRB] Device Select [Auto] </pre>	<p>Enables or Disables BIOS support for security device. O.S. will not show Security Device. TCG EFI protocol and INT1A interface will not be available.</p> <hr/> <p>←: Select Screen ↑↓: Select Item Enter: Select +/-: Change Opt. F1: General Help F2: Previous Values F3: Optimized Defaults F4: Save & Reset ESC: Exit</p>
--	--

Version 2.22.1293 Copyright (C) 2024 AMI

BIOS-Eintrag	Optionen
TPM 2.0 Device Found	
Firmware Version: 600.18	Keine
Vendor: INTC	Keine
Security Device Support	Enable / Disable
Active PCR banks	Keine
Available PCR banks	Keine
SHA256 PCR Bank	Enabled / Disabled
SHA384 PCR Bank	Disabled / Enabled
SM3_256 PCR Bank	Disabled / Enabled
Pending operation	None / TPM Clear
Platform Hierarchy	Enabled / Disabled
Storage Hierarchy	Enabled / Disabled
Endorsement Hierarchy	Enabled / Disabled
Physical Presence Spec Version	1.3 / 1.2
TPM 2.0 InterfaceType	Keine
Device Select	Auto / TPM 1.2 / TPM 2.0

7.3.4 ACPI Settings Disabled

Aptio Setup - AMI
Advanced

<p>ACPI Settings</p> <p>Enable ACPI Auto Configuration [Disabled]</p> <p>Enable Hibernation [Enabled]</p> <p>Lock Legacy Resources [Disabled]</p>	<p>Enables or Disables BIOS ACPI Auto Configuration.</p> <hr/> <p>←: Select Screen ↑↓: Select Item Enter: Select +/-: Change Opt. F1: General Help F2: Previous Values F3: Optimized Defaults F4: Save & Reset ESC: Exit</p>
---	--

Version 2.22.1293 Copyright (C) 2024 AMI

BIOS-Eintrag	Optionen
ACPI Settings	
Enable ACPI Auto Configuration	Disabled / Enabled
Enable Hibernation	Enabled / Disabled
Lock Legacy Resources	Disabled / Enabled

7.3.5 Hardware Monitor

Aptio Setup - AMI
Advanced

<p>Pc Health Status</p> <pre> CPU dig. : +30 'C VCCCORE : +0.78 V 5V : +5.06 V 12V : +12.49 V Memory VDD : +1.08 V 3.3V : +3.35 V FAN 1 : N/A FAN 2 : +3883 RPM FAN 3 : +3883 RPM MB Temp : +26 'C Memory Temp : +27 'C PwrCtrlTemp : +29 'C PwrCtrlVCC : +5.10 V </pre>	<pre> →: Select Screen ↑↓: Select Item Enter: Select +/-: Change Opt. F1: General Help F2: Previous Values F3: Optimized Defaults F4: Save & Reset ESC: Exit </pre>
--	---

Version 2.22.1293 Copyright (C) 2024 AMI

BIOS-Eintrag	Optionen
PC Health Status	
CPU dig.	Keine
VCCCORE	Keine
5V	Keine
12 V	Keine
Memory VDD	Keine
3.3V	Keine
FAN1	Keine
FAN 2	Keine
FAN 2	Keine
MB Temp	Keine
Memory Temp	Keine
PwrCtrlTemp	Keine
PwrCtrlVCC	Keine

7.3.6 AMI Graphic Output Protocol Policy

Aptio Setup - AMI
Advanced

Intel(R) Graphics Controller Intel(R) GOP Driver [17.0.1081] Output Select [DVI3[ACTIVE]]	Output Interface ←: Select Screen ↑↓: Select Item Enter: Select +/-: Change Opt. F1: General Help F2: Previous Values F3: Optimized Defaults F4: Save & Reset ESC: Exit
---	--

Version 2.22.1293 Copyright (C) 2024 AMI

BIOS-Eintrag	Optionen
Intel® Graphics Controller Intel® GOP Driver [17.0.1081]	
Output Select	Keine

7.3.7 PCI Subsystem Settings

Aptio Setup - AMI
Advanced

AMI PCI Driver Version A5.01.29 PCI Settings Common for all Devices: Re-Size BAR Support [Enabled] BME DMA Mitigation [Disabled] Change Settings of the Following PCI Devices: WARNING: Changing PCI Device(s) settings may have unwanted side effects! System may HANG! PROCEED WITH CAUTION.	If system has Resizable BAR capable PCIe Devices, this option Enables or Disables Resizable BAR Support. ←: Select Screen ↑↓: Select Item Enter: Select +/-: Change Opt. F1: General Help F2: Previous Values F3: Optimized Defaults F4: Save & Reset ESC: Exit
---	--

Version 2.22.1293 Copyright (C) 2024 AMI

BIOS-Eintrag	Optionen
AMI PCI Bus Driver Version	Keine
PCI Device Common Settings:	
Re-Size BAR Support	Enabled / Disabled
BME DMA Mitigation	Disabled / Enabled

7.3.8 USB Configuration

Aptio Setup - AMI
Advanced

USB Configuration USB Module Version 34 USB Controllers: 1 XHCI USB Devices: 1 Keyboard Legacy USB Support [Enabled] XHCI Hand-off off [Enabled] USB Mass Storage Driver Support [Enabled] USB hardware delays and time-outs: USB transfer time-out [20 sec] Device reset time-out [20 sec] Device power-up delay [Auto]	Enables Legacy USB support. AUTO option disables legacy support if no USB devices are connected. DISABLE option will keep USB devices available only for EFI applications. ←: Select Screen ↑↓: Select Item Enter: Select +/-: Change Opt. F1: General Help F2: Previous Values F3: Optimized Defaults F4: Save & Reset ESC: Exit
---	--

Version 2.22.1293 Copyright (C) 2024 AMI

BIOS-Eintrag	Optionen
USB Configuration	
USB Module Version	Keine
USB Controllers: 1XHCI	Keine
USB Devices: 1 Keyboard	Keine
Legacy USB Support	Enabled / Disabled / Auto
XHCI Hand-off	Enabled / Disabled
USB Mass Storage Driver Support	Enabled / Disabled
USB hardware delays and time-outs:	
USB transfer time-out	1 / 5 / 10 / 20 sec
Device reset time-out	10 / 20 / 30 / 40 sec
Device power-up delay	Auto / Manual

7.3.9 Network Stack Configuration enabled

Aptio Setup - AMI

Advanced

Network Stack [Enabled] Ipv4 PXE Support [Disabled] Ipv4 HTTP Support [Disabled] Ipv6 PXE Support [Disabled] Ipv6 HTTP Support [Disabled] PXE boot wait time 0 Media detect count 1	Enable/Disable UEFI Network Stack	←: Select Screen ↑↓: Select Item Enter: Select +/-: Change Opt. F1: General Help F2: Previous Values F3: Optimized Defaults F4: Save & Reset ESC: Exit
---	-----------------------------------	--

Version 2.22.1293 Copyright (C) 2024 AMI

BIOS-Eintrag	Optionen
Network Stack	Disabled / Enabled
Ipv4 PXE Support	Disabled / Enabled
Ipv4 HTTP Support	Disabled / Enabled
Ipv6 PXE Support	Disabled / Enabled
Ipv6 HTTP Support	Disabled / Enabled
PXE boot wait time	Keine
Media detect count	Keine

HINWEIS

PXE Boot verfügbar
 PXE Boot ist verfügbar wenn Sie Network Stack und Ipv4 PXE support auf „Enable“ stellen.

7.3.10 Power Controller Options

Aptio Setup - AMI
Advanced

Bootloader Version 1.02-05 Firmware Version 1.02-66 Mainboard Serial No 	1.02-05 1.02-66 -1.-1 30 21071min (351h) 4.90V / 5.20V 24'C /41'C	Select Power line for external USB devices, if powered-down
ext. USB-Port Voltage [Off in S3-5] int. USB-Port Voltage [Off in S3-5]	[Off in S3-5] [Off in S3-5]	--: Select Screen ↑↓: Select Item Enter: Select +/-: Change Opt. F1: General Help F2: Previous Values F3: Optimized Defaults F4: Save & Reset ESC: Exit
WatchDogTimer Mode [Normal Mode] WDT OSBoot Timeout [Disabled]	[Normal Mode] [Disabled]	

Version 2.22.1293 Copyright (C) 2024 AMI

BIOS-Eintrag	Optionen
Bootloader Version	Keine
Firmware Version	Keine
Mainboard Serial No	Keine
Mainboard Prod. Date (Week.Year)	Keine
Mainboard BootCount	Keine
Mainboard Operation Time	Keine
Voltage /Min/Max)	Keine
Temperature (Min/Max)	Keine
ext. USB-Port Voltage	Off in S3 - 5 / by SVCC
int. USB-Port Voltage	Off in S3 - 5 / by SVCC
WatchDogTimer Mode	Nomal Mode / Compatibility Mode
WDT OSBoot Timeout	Disabled / 45 / 60 / ... / 255 Seconds

7.3.11 NVMe Configuration

Aptio Setup - AMI
Advanced

NVMe Configuration No NVME Device Found	→: Select Screen ↑↓: Select Item Enter: Select +/-: Change Opt. F1: General Help F2: Previous Values F3: Optimized Defaults F4: Save & Reset ESC: Exit
--	--

Version 2.22.1293 Copyright (C) 2024 AMI

BIOS-Eintrag	Optionen
NVMe Configuration	
No NVME Device Found	Keine

7.3.12 TLs Auth Configuration

Aptio Setup - AMI
Advanced

<ul style="list-style-type: none"> ▶ Server CA Configuration ▶ Client Cert Configuration 	<p>Press <Enter> to configure Server CA.</p> <hr/> <p>←: Select Screen ↑↓: Select Item Enter: Select +/-: Change Opt. F1: General Help F2: Previous Values F3: Optimized Defaults F4: Save & Reset ESC: Exit</p>
--	--

Version 2.20.1290 Copyright (C) 2023 AMI

BIOS-Eintrag	Optionen
Server CA Configuration	Untermenü siehe: Server CA Configuration [▶ 62]
Client Cert Configuration	Keine

7.3.12.1 Server CA Configuration

Aptio Setup - AMI
Advanced

<ul style="list-style-type: none"> ▶ Enroll Cert ▶ Delete Cert 	<p>Press <Enter> to enroll cert.</p> <hr/> <p>←: Select Screen ↑↓: Select Item Enter: Select +/-: Change Opt. F1: General Help F2: Previous Values F3: Optimized Defaults F4: Save & Reset ESC: Exit</p>
--	--

Version 2.22.1293 Copyright (C) 2024 AMI

BIOS-Eintrag	Optionen
Enroll Cert	Untermenü siehe: Enroll Cert [▶ 63]
Delete Cert	Keine

7.3.12.1.1 Enroll Cert

Aptio Setup - AMI
Advanced

<ul style="list-style-type: none"> ▶ Enroll Cert Using File <li style="padding-left: 20px;">Cert GUID ▶ Commit Changes and Exit ▶ Discard Changes and Exit 	<p style="text-align: center;">Enroll Cert Using File</p> <hr/> <p>←: Select Screen ↑↓: Select Item Enter: Select +/-: Change Opt. F1: General Help F2: Previous Values F3: Optimized Defaults F4: Save & Reset ESC: Exit</p>
--	---

Version 2.22.1293 Copyright (C) 2024 AMI

BIOS-Eintrag	Optionen
Enroll Cert Using File	Keine
Cert GUID	Keine
Commit Changes and Exit	Keine
Discard Changes and Exit	Keine

7.3.13 Intel Rapid Storage Technology

Aptio Setup - AMI
Advanced

Intel (R) RST19.5.0.5676 RST VMD Driver No disks connected to System	←: Select Screen ↑↓: Select Item Enter: Select +/-: Change Opt. F1: General Help F2: Previous Values F3: Optimized Defaults F4: Save & Reset ESC: Exit
---	--

Version 2.22.1293 Copyright (C) 2024 AMI

BIOS-Eintrag	Optionen
Intel(R) RST 19.5.0.5676 RST VMD Driver	
No disks connected to system	Keine

7.3.14 Intel Ethernet Controller I226-IT

Aptio Setup - AMI
Advanced

UEFI Driver Device Name PCI Device ID Link Status PCI Address	Intel (R) Pro/1000 Open Source 4.9.99 PCI-E Intel (R) Ethernet Controller I226-IT 125D [Disconnected] 00:01:05:9C:87:9C	→: Select Screen ↑↓: Select Item Enter: Select +/-: Change Opt. F1: General Help F2: Previous Values F3: Optimized Defaults F4: Save & Reset ESC: Exit
---	--	--

Version 2.22.1293 Copyright (C) 2024 AMI

BIOS-Eintrag	Optionen
UEFI Driver	Keine
Device Name	Keine
PCI Device ID	Keine
Link Status	Keine
MAC Address	Keine

7.3.15 Intel Ethernet Controller I226-IT

Aptio Setup - AMI
Advanced

UEFI Driver Device Name PCI Device ID Link Status PCI Address	Intel (R) Pro/1000 Open Source 4.9.99 PCI-E Intel (R) Ethernet Controller I226-IT 125D [Disconnected] 00:01:05:9C:87:9D	→: Select Screen ↑↓: Select Item Enter: Select +/-: Change Opt. F1: General Help F2: Previous Values F3: Optimized Defaults F4: Save & Reset ESC: Exit
---	--	--

Version 2.22.1293 Copyright (C) 2024 AMI

BIOS-Eintrag	Optionen
UEFI Driver	Keine
Device Name	Keine
PCI Device ID	Keine
Link Status	Keine
MAC Address	Keine

7.3.16 Driver Health

Aptio Setup - AMI
Advanced

▶ Intel(R) PRO/1000 Open Source 4.9.99 PCI-E Healthy	Provides Health Status for the Drivers/Controllers
	←: Select Screen ↑↓: Select Item Enter: Select +/-: Change Opt. F1: General Help F2: Previous Values F3: Optimized Defaults F4: Save & Reset ESC: Exit

Version 2.22.1293 Copyright (C) 2024 AMI

BIOS-Eintrag	Optionen
▶ Intel® PRO/1000 Open Source 4.9.99 PCI-E	Keine

7.4 Chipset

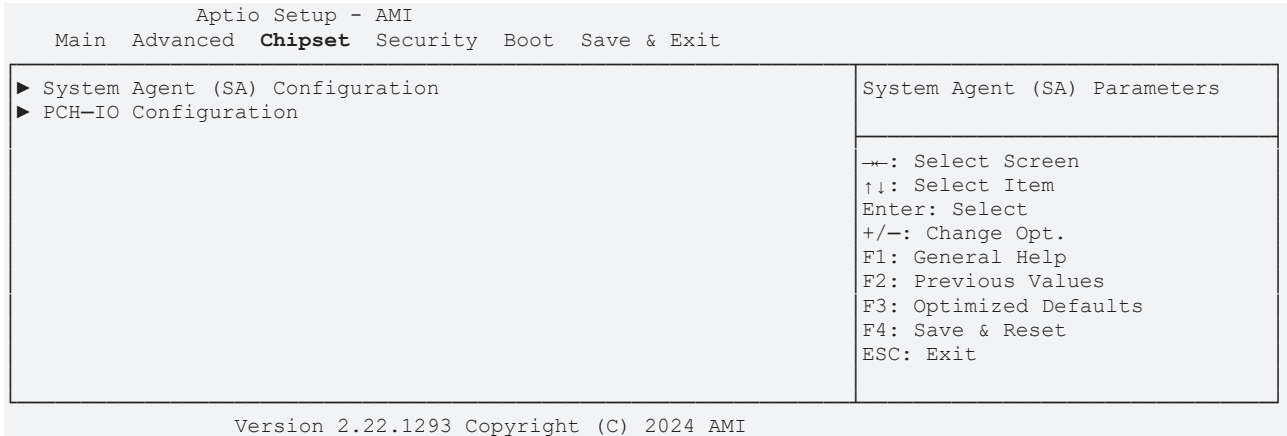

BIOS-Eintrag	Optionen
System Agent (SA) Configuration	Untermenü siehe: System Agent (SA) Configuration ▶ 69
PCH-IO Configuration	Untermenü siehe: PCH-IO Configuration ▶ 81

7.4.1.1.1 External GFX Card Primary Display Configuration Configuration

Aptio Setup - AMI
Chipset

External Gfx Card Primary Display Configuration	
	←: Select Screen ↓↑: Select Item Enter: Select +/-: Change Opt. F1: General Help F2: Previous Values F3: Optimized Defaults F4: Save & Reset ESC: Exit

Version 2.22.1293 Copyright (C) 2024 AMI

BIOS-Eintrag	Optionen
External Gfx Card Primary Display Configuration	

7.4.1.1.2 LCD Control

Aptio Setup – AMI
Chipset

<p>LCD Control</p> <p>Primary IGFX Boot Display [VBIOS Default] LCD Panel Type [VBIOS Default] Panel Scaling [Auto] Backlight Control [PWM Normal] Active LFP [eDP Port-A] Panel Color Depth [18 Bit] Backlight Brightness 255</p>	<p>Select the Video Device which will be activated during POST. This has no effect if external graphics present. Secondary boot display selection will appear based on your selection. VGA modes will be supported only on primary display</p> <hr/> <p>→: Select Screen ↑↓: Select Item Enter: Select +/-: Change Opt. F1: General Help F2: Previous Values F3: Optimized Defaults F4: Save & Reset ESC: Exit</p>
--	--

Version 2.22.1293 Copyright (C) 2024 AMI

BIOS-Eintrag	Optionen
LCD Control	
Primary IGFX Boot Display	VBIOS / EFP / LFP / EFP3 / EFP 2 / EFP4
LCD Panel Type	VBIOS Default / Various LVDS
Panel Scaling	Auto / Off / Force Scaling
Backlight Control	PWM Normal / PWM Inverted
Active LFP	eDP Port-A / No eDP
Panel Color Depth	18 / 24 Bit
Backlight Brightness	Keine

7.4.1.2 VMD setup menu

Aptio Setup - AMI
Chipset

VMD Configuration Enable VMD controller [Disabled] Enable VMD Global Mapping [Enabled] Map this Root Port under VMD [Enabled] Root Port BDF details SATA Controller RAID0 [Enabled] RAID1 [Enabled] RAID5 [Enabled] RAID10 [Enabled]	Enable/Disable to VMD controller ←: Select Screen ↑↓: Select Item Enter: Select +/-: Change Opt. F1: General Help F2: Previous Values F3: Optimized Defaults F4: Save & Reset ESC: Exit
--	--

Version 2.22.1290 Copyright (C) 2023 AMI

BIOS-Eintrag	Optionen
VMD Configuration	
Enable VMD controller	Disabled / Enabled
Enable VMD Global Mapping	Enabled / Disabled
Map this Root Port under VMD	Enabled / Disabled
Root Port BDF details	Keine
RAID0	Enabled / Disabled
RAID1	Enabled / Disabled
RAID5	Enabled / Disabled
RAID10	Enabled / Disabled

7.4.1.3 PCI Express Configuration

Aptio Setup - AMI
Chipset

PCI Express Configuration Fia Programming [Enabled] Compliance Test Mode [Disabled] CDR Relock [Enabled] Assertion on Link Down GPIOs [Disabled] PCI Express Slot Selection [M2] ▶ PCI Express Root Port 1 ▶ PCI Express Root Port 2 ▶ PCI Express Root Port 3	Load Fia Configuration if Enable for each root port. <hr/> ←: Select Screen ↓↑: Select Item Enter: Select +/-: Change Opt. F1: General Help F2: Previous Values F3: Optimized Defaults F4: Save & Reset ESC: Exit
--	--

Version 2.22.1293 Copyright (C) 2024 AMI

BIOS-Eintrag	Optionen
PCI Express Configuration	
Fia Programming	Enabled / Disabled
Compliance Test Mode	Disabled / Enabled
CDR Relock	Enabled / Disabled
Assertion on Link Down GPIOs	Disabled / Enabled
PCI Express Slot Selection	M2 / CEMx4 slot
PCI Express Root Port 1	Untermenü siehe: PCI Express Root Port 1 ▶ 75
PCI Express Root Port 2	Untermenü siehe: PCI Express Root Port 2 ▶ 77
PCI Express Root Port 3	Untermenü siehe: PCI Express Root Port 3 ▶ 79

7.4.1.3.1 PCI Express Root Port 1

Aptio Setup - AMI
Chipset

<pre> PCI Express Root Port 1 [Enabled] Connection Type [Slot] PCI Express Clock Gating [Disabled] PCI Express Power Gating [Enabled] ASPM [Disabled] L1 Substates [Disabled] Gen3 Eq Phase3 Method [Hardware] Gen4 Eq Phase3 Method [Hardware] ACS [Enabled] PTM [Enabled] DPC [Disabled] FOM Scoreboard Control Policy [Auto] Multi-VC [Enabled] EDPC [Enabled] URR [Enabled] FER [Enabled] NFER [Enabled] CER [Enabled] CTO [Disabled] SEFE [Disabled] SENFE [Disabled] SECE [Disabled] PME SCI [Enabled] Advanced Error Reporting [Enabled] PCIe Speed [Auto] Enable ClockReq Messaging [Enabled] Transmitter Half Swing [Disabled] Detect Timeout 0 P2P Support [Disabled] SA PCIe LTR Congguration LTR [Enabled] Snoop Latency Override [Auto] Non Snoop Latency Override [Auto] Force LTR Override [Disabled] LTR Lock [Disabled] CPU PCIe Gen3 HWEQ Config UPTP 5 DPTP 7 CPU PCIe Gen4 HWEQ Config UPTP 8 DPTP 9 </pre>	<p>▲ Control the PCI Express Root Port.</p> <hr/> <p>←: Select Screen ↑↓: Select Item Enter: Select +/-: Change Opt. F1: General Help F2: Previous Values F3: Optimized Defaults F4: Save & Reset ESC: Exit</p> <p>▼</p>
---	--

Version 2.22.1293 Copyright (C) 2024 AMI

BIOS-Eintrag	Optionen
PCI Express Root Port 1	Enabled / Disabled
Connection Type	Slot / Built - in
PCI Express Clock Gating	Keine
PCI Express Power Gating	Enabled / Disabled
ASPM	Keine
L1 Substates	Keine
Gen3 Eq Phase3 Method	Hardware / Static Coeff.
Gen4 Eq Phase3 Method	Hardware / Static Coeff.
ACS	Enabled / Disabled
PTM	Keine
DPC	Enabled / Disabled
FOM Scoreboard Control Policy	Auto / Gen3 / Gen4 / Gen3/Gen4 / Gen5
Multi-VC	Keine
EDPC	Enabled / Disabled
URR	Disabled / Enabled
FER	Disabled / Enabled
NFER	Disabled / Enabled
CER	Disabled / Enabled
CTO	Disabled / Enabled
SEFE	Disabled / Enabled
SENF	Disabled / Enabled
SECE	Disabled / Enabled
PME SCI	Enabled / Disabled
Advanced Error Reporting	Disabled / Enabled
PCIe Speed	Auto / Gen1 / Gen2 / Gen3 / Gen4
Enable ClockReq Messaging	Enabled / Disabled
Transmitter Half Swing	Disabled / Enabled
Detect Timeout	Keine
P2P Support	Disabled / Enabled
SA PCIe LTR Congguration	
LTR	Enabled / Disabled
Snoop Latency Override	Auto / Manual / Disabled
Non Snoop Latency Override	Auto / Manual / Disabled
Force LTR Override	Disabled / Enabled
LTR Lock	Disabled / Enabled
CPU PCIe Gen3 HWEQ Config	
UPTP	Keine
DPTP	Keine
CPU PCIe Gen4 HWEQ Config	
UPTP	Keine
DPTP	Keine

7.4.1.3.2 PCI Express Root Port 2

Aptio Setup - AMI
Chipset

<pre> PCI Express Root Port 2 [Enabled] Connection Type [Slot] PCI Express Clock Gating [Disabled] PCI Express Power Gating [Enabled] ASPM [Disabled] L1 Substates [Disabled] Gen3 Eq Phase3 Method [Hardware] Gen4 Eq Phase3 Method [Hardware] ACS [Enabled] PTM [Enabled] DPC [Disabled] FOM Scoreboard Control Policy [Auto] Multi-VC [Enabled] EDPC [Enabled] URR [Enabled] FER [Enabled] NFER [Enabled] CER [Enabled] CTO [Disabled] SEFE [Disabled] SENFE [Disabled] SECE [Disabled] PME SCI [Enabled] Advanced Error Reporting [Enabled] PCIe Speed [Auto] Enable ClockReq Messaging [Enabled] Transmitter Half Swing [Disabled] Detect Timeout 0 P2P Support [Disabled] SA PCIe LTR Congguration LTR [Enabled] Snoop Latency Override [Auto] Non Snoop Latency Override [Auto] Force LTR Override [Disabled] LTR Lock [Disabled] CPU PCIe Gen3 HWEQ Config UPTP 7 DPTP 7 CPU PCIe Gen4 HWEQ Config UPTP 7 DPTP 5 CPU PCIe Gen5 HWEQ Config UPTP 5 DPTP 5 </pre>	<p>▲ Control the PCI Express Root Port.</p> <hr/> <p>←: Select Screen ↑↓: Select Item Enter: Select +/-: Change Opt. F1: General Help F2: Previous Values F3: Optimized Defaults F4: Save & Reset ESC: Exit</p> <p style="text-align: center;">▼</p>
--	--

Version 2.22.1293 Copyright (C) 2024 AMI

BIOS-Eintrag	Optionen
PCI Express Root Port 2	Enabled / Disabled
Connection Type	Slot / Built-in
PCI Express Clock Gating	Enabled / Disabled
PCI Express Power Gating	Enabled / Disabled
ASPM	Disabled / Enabled
L1 Substates	L1.1 & L1.2 / L1.1 / Disabled
Gen3 Eq Phase3 Method	Hardware / Static Coeff.
Gen4 Eq Phase3 Method	Hardware / Static Coeff.
ACS	Enabled / Disabled
PTM	Enabled / Disabled
DPC	Enabled / Disabled
FOM Scoreboard Control Policy	Auto / Gen3 / Gen4 / Gen3 / Gen4
Multi-VC	Disabled / Enabled
EDPC	Enabled / Disabled
URR	Disabled / Enabled
FER	Disabled / Enabled
NFER	Disabled / Enabled
CER	Disabled / Enabled
CTO	Disabled / Enabled
SEFE	Disabled / Enabled
SENF	Disabled / Enabled
SECE	Disabled / Enabled
PME SCI	Enabled / Disabled
Advanced Error Reporting	Disabled / Enabled
PCIe Speed	Auto / Gen1 / Gen2 / Gen3 / Gen4
Enable ClockReq Messaging	Enabled / Disabled
Transmitter Half Swing	Disabled / Enabled
Detect Timeout	Keine
P2P Support	Disabled / Enabled
SA PCIe LTR Congguration	
LTR	Enabled / Disabled
Snoop Latency Override	Auto / Manual / Disabled
Non Snoop Latency Override	Auto / Manual / Disabled
Force LTR Override	Disabled / Enabled
LTR Lock	
LTR Lock	Disabled / Enabled
CPU PCIe Gen3 HWEQ Config	
UPTP	Keine
DPTP	Keine
CPU PCIe Gen4 HWEQ Config	
UPTP	Keine
DPTP	Keine
CPU PCIe Gen5 HWEQ Config	
UPTP	Keine
DPTP	Keine

7.4.1.3.3 PCI Express Root Port 3

Aptio Setup - AMI
Chipset

<pre> PCI Express Root Port 3 [Enabled] Connection Type [Slot] PCI Express Clock Gating [Disabled] PCI Express Power Gating [Enabled] ASPM [Disabled] L1 Substates [Disabled] Gen3 Eq Phase3 Method [Hardware] Gen4 Eq Phase3 Method [Hardware] ACS [Enabled] PTM [Enabled] DPC [Disabled] FOM Scoreboard Control Policy [Auto] Multi-VC [Enabled] EDPC [Enabled] URR [Enabled] FER [Enabled] NFER [Enabled] CER [Enabled] CTO [Disabled] SEFE [Disabled] SENFE [Disabled] SECE [Disabled] PME SCI [Enabled] Advanced Error Reporting [Enabled] PCIe Speed [Auto] Enable ClockReq Messaging [Enabled] Transmitter Half Swing [Disabled] Detect Timeout 0 P2P Support [Disabled] SA PCIe LTR Congguration LTR [Enabled] Snoop Latency Override [Auto] Non Snoop Latency Override [Auto] Force LTR Override [Disabled] LTR Lock [Disabled] CPU PCIe Gen3 HWEQ Config UPTP 7 DPTP 7 CPU PCIe Gen4 HWEQ Config UPTP 7 DPTP 5 CPU PCIe Gen5 HWEQ Config UPTP 5 DPTP 5 </pre>	<p>▲ Control the PCI Express Root Port.</p> <hr/> <p>←: Select Screen ↑↓: Select Item Enter: Select +/-: Change Opt. F1: General Help F2: Previous Values F3: Optimized Defaults F4: Save & Reset ESC: Exit</p>
---	---

Version 2.22.1293 Copyright (C) 2024 AMI

BIOS-Eintrag	Optionen
PCI Express Root Port 3	Enabled / Disabled
Connection Type	Slot / Built-in
PCI Express Clock Gating	Keine
PCI Express Power Gating	Enabled / Disabled
ASPM	Keine
L1 Substates	Keine
Gen3 Eq Phase3 Method	Hardware / Static Coeff.
Gen4 Eq Phase3 Method	Hardware / Static Coeff.
ACS	Enabled / Disabled
PTM	Keine
DPC	Enabled / Disabled
FOM Scoreboard Control Policy	Auto / Gen3 / Gen4 / Gen3/Gen4 / Gen5
Multi-VC	Keine
EDPC	Enabled / Disabled
URR	Disabled / Enabled
FER	Disabled / Enabled
NFER	Disabled / Enabled
CER	Disabled / Enabled
CTO	Disabled / Enabled
SEFE	Disabled / Enabled
SENF	Disabled / Enabled
SECE	Disabled / Enabled
PME SCI	Enabled / Disabled
Advanced Error Reporting	Disabled / Enabled
PCIe Speed	Auto / Gen1 / Gen2 / Gen3 / Gen4 / Gen5
Enable ClockReq Messaging	Enabled / Disabled
Transmitter Half Swing	Disabled / Enabled
Detect Timeout	Keine
P2P Support	Disabled / Enabled
SA PCIe LTR Congguration	
LTR	Enabled / Disabled
Snoop Latency Override	Auto / Manual / Disabled
Non Snoop Latency Override	Auto / Manual / Disabled
Force LTR Override	Disabled / Enabled
LTR Lock	
LTR Lock	Disabled / Enabled
CPU PCIe Gen3 HWEQ Config	
UPTP	Keine
DPTP	Keine
CPU PCIe Gen4 HWEQ Config	
UPTP	Keine
DPTP	Keine
CPU PCIe Gen5 HWEQ Config	
UPTP	Keine
DPTP	Keine

7.4.2 PCH-IO Configuration

Aptio Setup - AMI
Chipset

<p>PCH-IO Configuration</p> <ul style="list-style-type: none"> ▶ PCI Express Configuration ▶ SATA Configuration ▶ USB Configuration ▶ HD Audio Configuration <p>PCH LAN Controller [Enabled] Foxville I225 LAN Controller [Disabled] DeepSx Power Policies [Disabled] PS_ON Enable [Enabled] Wake on WLAN and BT Enable [Disabled] Disable DSX ACPRESANT PullDown [Disabled] State After G3 [S0 State] Port 80h Redirection [LPC Bus] Enhance Port 80h LPC Decoding [Enabled] Compatible Revision ID [Disabled] Legacy IO Low Latency [Enabled] PCH Cross Throttling [Enabled] PCH Energy Reporting [Enabled] LPM SOi2.0 [Enabled] LPM SOi2.1 [Enabled] C10 Dynamic threshold adjustment [Disabled] IEH Mode [Bypass Mode] Enable TCO Timer [Disabled] Enable Timed GPIO0 [Disabled] Enable Timed GPIO1 [Disabled] Pcie Pll SSC [Auto] Enable 8254 Clock Gate [Enabled] Lock PCH Sideband Access [Enabled] Flash Protection Range Registers (FPRR) [Disabled] SPD Write Disable [TRUE] LGMR [Disabled] HOST C10 reporting to Target [Disabled] OS IDLE Mode [Enabled] SOix Auto Demotion [Enabled] Latch Events C10 Exit [Disabled] Hybrid Storage Detection and Configuration Mode [Disabled] Extended BIOS Range Decode [Disabled] ACPI L6D PME Handling [Disabled]</p>	<p>▲ PCI Express Configuration settings</p> <hr/> <p>←→: Select Screen ↓↑: Select Item Enter: Select +/-: Change Opt. F1: General Help F2: Previous Values F3: Optimized Defaults F4: Save & Reset ESC: Exit</p>
---	--

Version 2.22.1293 Copyright (C) 2024 AMI

BIOS-Eintrag	Optionen
PCH-IO Configuration	
PCI Express Configuration	Untermenü siehe: PCI Express Configuration [► 83]
SATA Configuration	Untermenü siehe: SATA Configuration [► 86]
USB Configuration	Untermenü siehe: USB Configuration [► 89]
HD Audio Configuration	Untermenü siehe: HD Audio Configuration [► 91]
PCH LAN Controller	Enabled / Disabled
Foxville I225 LAN Controller	Enabled / Disabled
DeepSx Power Policies	Disabled / Enabled
PS_ON Enable	Disabled / Enabled
Wake on LAN and BT Enable	Disabled / Enabled
Disable DSX ACPRESENT Pull Down	Disable / Enabled
State After G3	S0 State / S5 State
Port 80h Redirection	LPC Bus / PCIE Bus
Enhance Port 80h LPC Decoding	Enabled / Disabled
Compatible Revision ID	Keine
Legacy IO Low Latency	Keine
PCH Cross Throttling	Enabled / Disabled
PCH Energy Reporting	Enabled / Disabled
LPM SOi2.0	Enabled / Disabled
LPM SOi2.1	Enabled / Disabled
Second LAN Controller	Enabled / Disabled
C10 Dynamic threshold adjustment	Disabled / Enabled
IEH Mode	Bypass Mode / Enabled
Enable TCO Timer	Disabled / Enabled
Enable Timed GPIO0	Enabled / Disabled
Enable Timed GPIO1	Enabled / Disabled
Pcie Pll SSC	Auto / 0.0%...0.5% / Disabled
Enable 8254 Clock Gate	Enabled / Disabled
Lock PCH Sideband Access	Enabled / Disabled
Flash Protection Range Registers (FPRR)	Disabled / Enabled
SPD Write Disable	True / False
LGMR	Disabled / Enabled
HOST_C10 reporting to Target	Disabled / Enabled
OS IDLE Mode	Enabled / Disabled
SOix Auto Demotion	Enabled / Disabled
Latch Events C10 Exit	Disabled / Enabled
Hybrid Storage Detection and Configuration Mode	Disabled / Enabled
Extended BIOS Range Decode	Disabled / Enabled
ACPI L6D PME Handling	Disabled / Enabled

7.4.2.1.1 PCI Express Root Port 1

Aptio Setup - AMI
Chipset

<pre> PCI Express Root Port 1 [Enabled] Connection Type [Slot] ASPM [Disabled] L1 Substates [Disabled] L1 Low [Disabled] ACS [Enabled] PTM [Enabled] DPC [Disabled] EDPC [Enabled] URR [Disabled] FER [Disabled] NFER [Disabled] CER [Disabled] SEFE [Disabled] SENFE [Disabled] SECE [Disabled] PME SCI [Enabled] Hot Plug [Disabled] Advanced Error Reporting [Enabled] PCIe Speed [Auto] Transmitter Half Swing [Disabled] Detect Timeout 0 Extra Bus Reserved 0 Reserved Memory 10 Reserved I/O 4 PCH PCIe LTR Configuration LTR [Enabled] Snoop Latency Override [Auto] Non Snoop Latency Override [Auto] LTR Lock [Disabled] Peer Memory Write Enable [Disabled] </pre>	▲ ▼	<p>Control the PCI Express Root Port.</p> <p>→: Select Screen ↑↓: Select Item Enter: Select +/-: Change Opt. F1: General Help F2: Previous Values F3: Optimized Defaults F4: Save & Reset ESC: Exit</p>
--	--------	---

Version 2.22.1293 Copyright (C) 2024 AMI

BIOS-Eintrag	Optionen
PCI Express Root Port 1	Disabled / Enabled
Connection Type	Built-in / Slot
ASPM	Disabled / Enabled
L1 Substates	Disabled / Enabled
L1 Low	Disabled / Enabled
ACS	Enabled / Disabled
PTM	Enabled / Disabled
DPC	Enabled / Disabled
EDPC	Enabled / Disabled
URR	Disabled / Enabled
FER	Disabled / Enabled
NFER	Disabled / Enabled
CER	Disabled / Enabled
SEFE	Disabled / Enabled
SENF	Disabled / Enabled
PME SCI	Enabled / Disabled
Hot Plug	Disabled / Enabled
Advanced Error Reporting	Enabled / Disabled
PCIe Speed	Auto / Gen1 / Gen2 / Gen3 / Gen4
Transmitter Half Swing	Disabled / Enabled
Detect Timeout	Keine
Extra Bus Reserved	Keine
Reserved Memory	Keine
Reserved I/O	Keine
PCH PCIe LTR Configuration	
LTR	Enabled / Disabled
Snoop Latency Override	Disabled / Manual / Auto
Non Snoop Latency Override	Disabled / Manual / Auto
LTR Lock	Disabled / Enabled
Peer Memory Write Enable	Disabled / Enabled

HINWEIS

PCI Express Configuration
 Die BIOS-Einträge und die Optionen an den Ports 1 - 2, 4, 5, 9, 13 – 16, 21, 25 sind identisch. Beispielhaft ist der Port 1 dargestellt

7.4.2.2 SATA Configuration

Aptio Setup - AMI
Chipset

<p>SATA Configuration</p> <p>SATA Controller(s) [Enabled] SATA Test Mode [Disabled] Aggressive LPM Support [Enabled]</p> <p>Serial ATA Port 0 Empty Software Preserve Unknown Port 0 [Enabled] Hot Plug [Disabled] Configured as eSATA Hot Plug Supported External [Disabled] Spin Up Device [Disabled] SATA Device Type [Hard Disk Drive] Topology [Unknown] SATA Port 0 DevSlp [Disabled] DITO Configuration [Disabled] DITO Value 625 DM Value 15</p> <p>Serial ATA Port 1 Empty Software Preserve Unknown Port 1 [Enabled] Hot Plug [Disabled] Configured As eSATA Hot Plug Supported External [Disabled] Spin Up Device [Disabled] SATA Device Type [Hard Disk Drive] Topology [Unknown] SATA Port 1 DevSlp [Disabled] DITO Configuration [Disabled] DITO Value 625 DM Value 15</p> <p>Serial ATA Port 2 Empty Software Preserve Unknown Port 2 [Enabled] Hot Plug [Disabled] Configured As eSATA Hot Plug Supported External [Disabled] Spin Up Device [Disabled] SATA Device Type [Hard Disk Drive] Topology [Unknown] SATA Port 2 DevSlp [Disabled] DITO Configuration [Disabled] DITO Value 625 DM Value 15</p> <p>Serial ATA Port 3 Empty Software Preserve Unknown Port 3 [Enabled] Hot Plug [Disabled] Configured As eSATA Hot Plug Supported External [Disabled] Spin Up Device [Disabled] SATA Device Type [Hard Disk Drive] Topology [Unknown] SATA Port 3 DevSlp [Disabled] DITO Configuration [Disabled] DITO Value 625 DM Value 15</p> <p>Serial ATA Port 4 Empty Software Preserve Unknown Port 4 [Enabled] Hot Plug [Disabled] Configured As eSATA Hot Plug Supported External [Disabled] Spin Up Device [Disabled] SATA Device Type [Hard Disk Drive] Topology [Unknown] SATA Port 4 DevSlp [Disabled] DITO Configuration [Disabled] DITO Value 625 DM Value 15</p> <p>Serial ATA Port 5 Empty Software Preserve Unknown Port 5 [Enabled] Hot Plug [Disabled]</p>	<p>▲ Enable/Disable SATA Device.</p> <hr/> <p>←: Select Screen ↑: Select Item Enter: Select +/-: Change Opt. F1: General Help F2: Previous Values F3: Optimized Defaults F4: Save & Reset ESC: Exit</p>
---	---

Configured As eSATA	Hot Plug Supported
External	[Disabled]
Spin Up Device	[Disabled]
SATA Device Type	[Hard Disk Drive]
Topology	[Unknown]
SATA Port 5 DevSlp	[Disabled]
DITO Configuration	[Disabled]
DITO Value	625
DM Value	15
Serial ATA Port 6	Empty
Software Preserve	Unknown
Port 6	[Enabled]
Hot Plug	[Disabled]
Configured As eSATA	Hot Plug Supported
External	[Disabled]
Spin Up Device	[Disabled]
SATA Device Type	[Hard Disk Drive]
Topology	[Unknown]
SATA Port 6 DevSlp	[Disabled]
DITO Configuration	[Disabled]
DITO Value	625
DM Value	15
Serial ATA Port 7	Empty
Software Preserve	Unknown
Port 7	[Enabled]
Hot Plug	[Disabled]
Configured As eSATA	Hot Plug Supported
External	[Disabled]
Spin Up Device	[Disabled]
SATA Device Type	[Hard Disk Drive]
Topology	[Unknown]
SATA Port 7 DevSlp	[Disabled]
DITO Configuration	[Disabled]
DITO Value	625
DM Value	15

Version 2.22.1293 Copyright (C) 2024 AMI

BIOS-Eintrag	Optionen
SATA Configuration	
SATA Controller(s)	Enabled / Disabled
SATA Test Mode	Disabled / Enabled
Serial ATA Port 0	Keine
Software Preserve	Keine
Port 0	Enabled / Disabled
Hot Plug	Disabled / Enabled
Configured as eSATA	Keine
External	Disabled / Enabled
Spin Up Device	Disabled / Enabled
SATA Device Type	Hard Disk Drive / Solid State Drive
Topology	Unknown / ISATA / Direct Connect / Flex / M2
SATA Port 0 DevSlp	Disabled / Enabled
DITO Configuration	Disabled / Enabled
DITO Value	Keine
DM Value	Keine

HINWEIS

SATA Configuration

Die BIOS-Einträge und die Optionen an den SATA Ports 1 - 7 sind identisch. Beispielhaft ist Port 0 dargestellt.

BIOS-Eintrag	Optionen
USB Configuration	
xDCI Support	Enabled / Disabled
USB PDO Programming	Enabled / Disabled
USB Overcurrent	Enabled / Disabled
USB Overcurrent Lock	Enabled / Disabled
USB Audio Offload	Enabled / Disabled
Enable HSII on xHCI	Enabled / Disabled
USB3.1 Portx Speed Selection	Keine
USB SS Physical Connector #0	Enabled / Disabled
USB SS Physical Connector #1	Enabled / Disabled
USB SS Physical Connector #2	Enabled / Disabled
USB SS Physical Connector #3	Enabled / Disabled
USB SS Physical Connector #4	Enabled / Disabled
USB SS Physical Connector #5	Enabled / Disabled
USB SS Physical Connector #6	Enabled / Disabled
USB SS Physical Connector #7	Enabled / Disabled
USB SS Physical Connector #8	Enabled / Disabled
USB SS Physical Connector #9	Enabled / Disabled
USB HS Physical Connector #1	Enabled / Disabled
USB HS Physical Connector #2	Enabled / Disabled
USB HS Physical Connector #3	Enabled / Disabled
USB HS Physical Connector #4	Enabled / Disabled
USB HS Physical Connector #5	Enabled / Disabled
USB HS Physical Connector #6	Enabled / Disabled
USB HS Physical Connector #7	Enabled / Disabled
USB HS Physical Connector #8	Enabled / Disabled
USB HS Physical Connector #9	Enabled / Disabled
USB HS Physical Connector #10	Enabled / Disabled
USB HS Physical Connector #11	Enabled / Disabled
USB HS Physical Connector #12	Enabled / Disabled
USB HS Physical Connector #13	Enabled / Disabled

7.4.2.4 HD Audio Configuration

Aptio Setup - AMI
Chipset

<p>HD Audio Subsystem Configuration Settings</p> <p>HD Audio [Enabled]</p> <p>Audio DSP [Enabled]</p> <p>Audio DSP Compliance Mode [Non-UAA (IntelSST)]</p> <p>HDA Link [Enabled]</p> <p>DMIC #0 [Enabled]</p> <p>Dmic Clock Source Select [ClkA]</p> <p>DMIC #1 [Enabled]</p> <p>Dmic Clock Source Select [ClkA]</p> <p>SSP #0 [Disabled]</p> <p>SSP #1 [Disabled]</p> <p>SSP #2 [Disabled]</p> <p>SNDW #1 [Disabled]</p> <p>SNDW #2 [Disabled]</p> <p>SNDW #3 [Disabled]</p> <p>SNDW #4 [Disabled]</p> <p>▶ HD Audio Advanced Configuration</p> <p>▶ HD Audio DSP Features Configuration</p> <p>HD Audio Bus Controller Subsystem Id [72708086]</p> <p>Virtual Channel Type [VC0]</p> <p>HDA Codec ALC245 Configuration [No Dmic to codec]</p>	<p>Control Detection of the HD-Audio device. Disabled = HDA will be unconditionally disabled Enabled = HDA will be unconditionally enabled.</p> <hr/> <p>←: Select Screen ↑↓: Select Item Enter: Select +/-: Change Opt. F1: General Help F2: Previous Values F3: Optimized Defaults F4: Save & Reset ESC: Exit</p>
--	---

Version 2.22.1293 Copyright (C) 2024 AMI

BIOS-Eintrag	Optionen
HD Audio Subsystem Configuration Settings	
HD Audio	Enabled / Disabled
Audio DSP	Enabled / Disabled
Audio DSP Compliance Mode	Non-UAA (IntelSST) / UAA (HDA Inbox/IntelSST)
HDA Link	Enabled / Disabled
DMIC #0	Enabled / Disabled
Dmic Clock Source Select	CLKA / CLB / Both
DMIC #1	Enabled / Disabled
Dmic Clock Source Select	CLKA / CLB / Both
SSP #0	Keine
SSP #1	Disabled / Enabled
SSP #2	Disabled / Enabled
SNDW #1	Keine
SNDW #2	Disabled / Enabled
SNDW #3	Keine
SNDW #4	Keine
HD Audio Advanced Configuration	Untermenü siehe: HD Audio Subsystem Advanced Configuration Settings [▶ 92]
HD Audio DSP Features Configuration	Untermenü siehe: HD Audio Subsystem Feature Configuration (ACPI) [▶ 94]
HD Audio Bus Controller Subsystem ID	Various
Virtual Channel Type	VC0 / VC1
HDA Codec ALC245 Configuration	No Dmic to codec / 4 Dmic to codec / 2 Dmic to codec

7.4.2.4.1 HD Audio Subsystem Advanced Configuration Settings

Aptio Setup - AMI
Chipset

<p>HD Audio Subsystem Advanced Configuration Settings</p> <p>iDisplay Audio Disconnect [Disabled]</p> <p>Codec Sx Wake Capability [Disabled]</p> <p>PME Enable [Disabled]</p> <p>Statically Switchable BCLK Clock</p> <p>Frequency Configuration:</p> <p style="padding-left: 20px;">HD Audio Link Frequency [24 MHz]</p> <p style="padding-left: 20px;">iDisplay Audio Link Frequency [96 MHz]</p> <p style="padding-left: 20px;">iDisplay Audio Link T-Mode [8T Mode]</p> <p>Autonomous Clock Stop SNDW #1 [Disabled]</p> <p>Autonomous Clock Stop SNDW #2 [Disabled]</p> <p>Autonomous Clock Stop SNDW #3 [Disabled]</p> <p>Autonomous Clock Stop SNDW #4 [Disabled]</p> <p>Data On Active Interval Select SNDW #1 [11 clock periods]</p> <p>Data On Active Interval Select SNDW #2 [11 clock periods]</p> <p>Data On Active Interval Select SNDW #3 [11 clock periods]</p> <p>Data On Active Interval Select SNDW #4 [11 clock periods]</p> <p>Data On Delay Select SNDW #1 [3 clock periods]</p> <p>Data On Delay Select SNDW #2 [3 clock periods]</p> <p>Data On Delay Select SNDW #3 [3 clock periods]</p> <p>Data On Delay Select SNDW #4 [3 clock periods]</p> <p>ACX SSID 305610EC Codecs Topology [Disabled]</p>	<p>▲ Disconnects SDI2 signal to hide/disable iDisplay Audio Codec.</p> <hr/> <p>←: Select Screen ↑↓: Select Item Enter: Select +/-: Change Opt. F1: General Help F2: Previous Values F3: Optimized Defaults F4: Save & Reset ESC: Exit</p> <p>▼</p>
---	---

Version 2.22.1293 Copyright (C) 2024 AMI

BIOS-Eintrag	Optionen
HD Audio Subsystem Advanced Configuration Settings	
iDisplay Audio Disconnect	Disabled / Enabled
Codec Sx Wake Capability	Disabled / Enabled
PME Enable	Disabled / Enabled
Statically Switchable BCLK Clock Frequency Configuration	
HD Audio Link Frequency	24 / 6 / 12 MHz
iDisplay Audio Link Frequency	96 / 48 MHz
iDisplay Audio Link T-Mode	8T Mode / 1T Mode / 2T Mode / 4T Mode / 16T Mode
Autonomous Clock Stop SNDW #1	Disabled / Enabled
Autonomous Clock Stop SNDW #2	Disabled / Enabled
Autonomous Clock Stop SNDW #3	Disabled / Enabled
Autonomous Clock Stop SNDW #4	Disabled / Enabled
Data On Active Interval Select SNDW #1	11 clock periods / 6, 7, 8 clock periods
Data On Active Interval Select SNDW #2	11 clock periods / 6, 7, 8 clock periods
Data On Active Interval Select SNDW #3	11 clock periods / 6, 7, 8 clock periods
Data On Active Interval Select SNDW #4	11 clock periods / 6, 7, 8 clock periods
Data On Delay Select SNDW #1	3 clock periods / 2 clock periods
Data On Delay Select SNDW #2	3 clock periods / 2 clock periods
Data On Delay Select SNDW #3	3 clock periods / 2 clock periods
Data On Delay Select SNDW #4	3 clock periods / 2 clock periods
ACX SSID 305610EC Codecs Topology	Disabled / Enabled

7.4.2.4.2 HD Audio Subsystem Feature Configuration (ACPI)

Aptio Setup - AMI
Chipset

<p>HD Audio Subsystem Features Configuration (ACPI)</p> <p>Audio DSP NHLT Endpoints Configuration:</p> <p>Dmic Mono 38.4MHz [Disabled]</p> <p>Dmic Stereo 38.4MHz [Disabled]</p> <p>Dmic Quad 38.4MHz [Disabled]</p> <p>Dmic Mono 24MHz [Disabled]</p> <p>Dmic Stereo 24MHz [Disabled]</p> <p>Dmic Quad 24MHz [Disabled]</p> <p>Bluetooth 38.4MHz [Disabled]</p> <p>Bluetooth 24MHz [Disabled]</p> <p>I2S Alc274 38.4MHz [Disabled]</p> <p>I2S Alc274 24MHz [Disabled]</p> <p>LONTIUMI2S0 [Disabled]</p> <p>LONTIUMI2S2 [Disabled]</p> <p>EVEREST8316 [Disabled]</p> <p>I2S Codec Select [Disabled]</p> <p>I2S Codec Bus Number [I2SC0 Controller]</p> <p>Audio DSP Feature Support:</p> <p>WoV (Wake on Voice) [Enabled]</p> <p>Bluetooth Sideband [Enabled]</p> <p>BT Intel HFP [Enabled]</p> <p>BT Intel A2DP [Enabled]</p> <p>BT Intel LE Audio [Enabled]</p> <p>ACX/SDCA [Disabled]</p> <p>ACX/SDCA speaker aggregation [Disabled]</p> <p>Codec based VAD [Disabled]</p> <p>DSP based Speech [Disabled]</p> <p>Pre-Processing disabled</p> <p>Voice Activity Detection [Windows 10 Voice Activation]</p> <p>Audio DSP Pre/Post-Processing Module Support:</p> <p>Waves Post-process [Disabled]</p> <p>DTS [Disabled]</p> <p>IntelSST Speech [Disabled]</p> <p>Dolby [Disabled]</p> <p>Waves Pre-process [Disabled]</p> <p>Audyssey [Disabled]</p> <p>Maxim Smart AMP [Disabled]</p> <p>ForteMedia SAMSoft [Disabled]</p> <p>Sound Research IP [Disabled]</p> <p>Conexant Pre-Process [Disabled]</p> <p>Conexant Smart Amp [Disabled]</p> <p>Realtek Post-Process [Disabled]</p> <p>Realtek Smart Amp [Disabled]</p> <p>Icepower IP MFX sub module [Disabled]</p> <p>Icepower IP EFX sub module [Disabled]</p> <p>Icepower IP SFX sub module [Disabled]</p> <p>Voice Preprocessing [Disabled]</p> <p>Acoustic Context Awareness (ACA) [Disabled]</p> <p>Custom Module 'Alpha' [Disabled]</p> <p>Custom Module 'Beta' [Disabled]</p> <p>Custom Module 'Gamma' [Disabled]</p>	<p>▲ Enables/Disables 1 Mic Array Endpoint in NHLT ACPI table. XTAL: 38.4Mhz.</p> <p>←: Select Screen ↑↓: Select Item Enter: Select +/-: Change Opt. F1: General Help F2: Previous Values F3: Optimized Defaults F4: Save & Reset ESC: Exit</p> <p style="text-align: center;">▼</p>
---	--

Version 2.22.1293 Copyright (C) 2024 AMI

BIOS-Eintrag	Optionen
HD Audio Subsystem Features Configuration (ACPI)	
Audio DSP NHLT Endpoints Configuration:	
Dmic Mono 38.4MHz	Disabled / Enabled
Dmic Stereo 38.4MHz	Disabled / Enabled
Dmic Quad 38.4MHz	Disabled / Enabled
Dmic Mono 24MHz	Disabled / Enabled
Dmic Stereo 24MHz	Disabled / Enabled
Dmic Quad 24MHz	Disabled / Enabled
Bluetooth 38.4MHz	Keine
Bluetooth 24MHz	Keine
I2S Alc274 38.4MHz	Keine
I2S Alc274 24MHz	Keine
LONTIUMI2S0	Keine
LONTIUMI2S2	Keine
EVEREST8316	Keine
I2S Codec Select	Keine
I2S Codec Bus Number	Keine
Audio DSP Feature Support:	
WoV (Wake on Voice)	Enabled / Disabled
Bluetooth Sideband	Enabled / Disabled
BT Intel HFP	Enabled / Disabled
BT Intel A2DP	Enabled / Disabled
BT Intel LE Audio	Disabled / Enabled
ACX/SDCA	Disabled / Enabled
ACX/SDCA speaker aggregation	Keine
Codec based VAD	Disabled / Enabled
DSP based Speech	Keine
Pre-Processing Disabled	Keine
Voice Activity Detection	Windows 10 Voice Activation / Intel Wake on Voice
Audio DSP Pre/Post-Processing Module Support:	
Waves Post-process	Disabled / Enabled
DTS	Disabled / Enabled
IntelSST Speech	Disabled / Enabled
Dolby	Disabled / Enabled
Waves Pre-process	Disabled / Enabled
Audyssey	Disabled / Enabled
Maxim Smart AMP	Disabled / Enabled
ForteMedia SAMSoft	Disabled / Enabled
Sound Research IP	Disabled / Enabled
Conexant Pre-Process	Disabled / Enabled
Conexant Smart Amp	Disabled / Enabled
Realtek Post-Process	Disabled / Enabled
Realtek Post-Process	Disabled / Enabled

BIOS-Eintrag	Optionen
Icepower IP MFX sub module	Disabled / Enabled
Icepower IP EFX sub module	Disabled / Enabled
Icepower IP SFX sub module	Disabled / Enabled
Voice Preprocessing	Disabled / Enabled
Acoustic Context Awareness (ACA	Disabled / Enabled
Custom Module 'Alpha'	Disabled / Enabled
Custom Module 'Beta'	Disabled / Enabled
Custom Module 'Gamma'	Disabled / Enabled

7.5.1 Secure Boot

Aptio Setup - AMI
Security

System Mode Secure Boot Secure Boot Mode ▶ Restore Factory Keys ▶ Reset To Setup Mode ▶ Key Management	User [Disabled] Not Active [Custom]	Secure Boot feature is Active if Secure Boot is Enabled, Platform Key(PK) is enrolled and the System is in User mode. The mode change requires platform reset ←: Select Screen ↓↑: Select Item Enter: Select +/-: Change Opt. F1: General Help F2: Previous Values F3: Optimized Defaults F4: Save & Reset ESC: Exit
---	--	---

Version 2.22.1293 Copyright (C) 2024 AMI

BIOS-Eintrag	Optionen
System Mode	Keine
Secure Boot	Disabled / Enabled Not Active
Secure Boot Mode	Custom / Standard
Restore Factory Keys	Untermenü siehe: Restore Factory Keys [▶ 99]
Reset To Setup Mode	Untermenü siehe: Reset To Setup Mode [▶ 100]
Key Management	Untermenü siehe: Key Management [▶ 101]

7.5.1.1 Restore Factory Keys

Aptio Setup - AMI
Security

System Mode	User	Force System to User Mode. Install factory default Secure Boot key databases
Secure Boot	[Disabled] Not Active	
Secure Boot Mode	[Custom]	Install factory defaults Press 'Yes' to proceed 'No' to cancel _____ Yes No
▶ Restore Factory Keys		
▶ Reset To Setup Mode		
▶ Key Management		

elect Screen
 elect Item
 : Select
 Change Opt.
 F1: General Help
 F2: Previous Values
 F3: Optimized Defaults
 F4: Save & Reset
 ESC: Exit

Version 2.22.1293 Copyright (C) 2024 AMI

BIOS-Eintrag	Optionen
System Mode	Keine
Secure Boot	Disabled / Enabled
Secure Boot Mode	Custom / Standard
Restore Factory Keys	Install factory defaults, siehe Kasten

7.5.1.2 Reset To Setup Mode

Aptio Setup - AMI
Security

System Mode Secure Boot Secure Boot Mode ▶ Restore Factory Keys ▶ Reset To Setup Mode ▶ Key Management	User [Disabled] Not Active [Custom] Reset To Setup Mode	Delete all Secure Boot key databases from NVRAM elect Screen elect Item : Select Change Opt. eneral Help F2: Previous Values F3: Optimized Defaults F4: Save & Reset ESC: Exit
---	---	---

Deleting all variables will reset the System to Setup Mode
Do you want to proceed?

Yes No

Version 2.22.1293 Copyright (C) 2024 AMI

BIOS-Eintrag	Optionen
System Mode	keine
Secure Boot	Disabled / Enabled Not Active
Secure Boot Mode	Custom / Standard
Reset To Setup Mode	Reset To Setup Mode, siehe Kasten

7.5.1.3 Key Management

Aptio Setup - AMI
Security

Vendor Keys Factory Key Provision [Enabled] ▶ Restore Factory Keys ▶ Reset To Setup Mode ▶ Enroll EFI Image ▶ Export Secure Boot variables <table style="width: 100%; border-collapse: collapse;"> <thead> <tr> <th style="text-align: left;">Secure Boot variable</th> <th style="text-align: right;">Size</th> <th style="text-align: right;">Keys</th> <th style="text-align: left;">Key Source</th> </tr> </thead> <tbody> <tr> <td>▶ Platform Key (PK)</td> <td style="text-align: right;">862</td> <td style="text-align: right;">1</td> <td>Test (AMI)</td> </tr> <tr> <td>▶ Key Exchange Keys (KEK)</td> <td style="text-align: right;">1560</td> <td style="text-align: right;">1</td> <td>Factory</td> </tr> <tr> <td>▶ Authorized Signatures (db)</td> <td style="text-align: right;">3143</td> <td style="text-align: right;">2</td> <td>Factory</td> </tr> <tr> <td>▶ Forbidden Signatures (dbx)</td> <td style="text-align: right;">17836</td> <td style="text-align: right;">71</td> <td>Factory</td> </tr> <tr> <td>▶ Authorized TimeStamps (dbt)</td> <td style="text-align: right;">0</td> <td style="text-align: right;">0</td> <td>No Keys</td> </tr> <tr> <td>▶ OsRecovery Signatures (dbr)</td> <td style="text-align: right;">0</td> <td style="text-align: right;">0</td> <td>No Keys</td> </tr> </tbody> </table>	Secure Boot variable	Size	Keys	Key Source	▶ Platform Key (PK)	862	1	Test (AMI)	▶ Key Exchange Keys (KEK)	1560	1	Factory	▶ Authorized Signatures (db)	3143	2	Factory	▶ Forbidden Signatures (dbx)	17836	71	Factory	▶ Authorized TimeStamps (dbt)	0	0	No Keys	▶ OsRecovery Signatures (dbr)	0	0	No Keys	Modified [Enabled]	Install factory default Secure Boot keys after the platform reset and while the System is in Setup mode ←: Select Screen ↓↑: Select Item Enter: Select +/-: Change Opt. F1: General Help F2: Previous Values F3: Optimized Defaults F4: Save & Reset ESC: Exit
Secure Boot variable	Size	Keys	Key Source																											
▶ Platform Key (PK)	862	1	Test (AMI)																											
▶ Key Exchange Keys (KEK)	1560	1	Factory																											
▶ Authorized Signatures (db)	3143	2	Factory																											
▶ Forbidden Signatures (dbx)	17836	71	Factory																											
▶ Authorized TimeStamps (dbt)	0	0	No Keys																											
▶ OsRecovery Signatures (dbr)	0	0	No Keys																											

Version 2.22.1293 Copyright (C) 2024 AMI

BIOS-Eintrag	Optionen
Vendor Keys	Keine
Factory Key Provision	Disabled / Enabled
Restore Factory Keys	Untermenü siehe: Restore Factory Keys [▶ 102]
Reset To Setup Mode	Untermenü siehe: Reset To Setup Mode [▶ 103]
Enroll Efi Image	Untermenü siehe: Enroll Efi Image [▶ 104]
Export Secure Boot variables	Untermenü siehe: Export Secure Boot variables [▶ 104]
Secure Boot variables	
PlatformKey(PK)	Eingabetaste drücken
Key Exchange Keys (KEK)	Eingabetaste drücken
Authorized Signatures (db)	Eingabetaste drücken
Forbidden Signatures (dbx)	Eingabetaste drücken
Authorized TimeStamps (dbt)	Eingabetaste drücken
OsRecovery Signatures (dbr)	Eingabetaste drücken

7.5.1.3.1 Restore Factory Keys

```

Aptio Setup - AMI
Security

Vendor Keys                               Modified
Factory Key Provision                     [Enabled]
▶ Restore Factory Keys
▶ Reset To Setup Mode
▶ Export Secure Boot variables
▶ Enroll Efi Image

Secure Boot variable | Size| Keys| Key Source
▶ Platform Key       (PK) |   |   | Install factory defaults
▶ Key Exchange Keys (KEK) |   |   |
▶ Authorized Signatures (db) |   |   |
▶ Forbidden Signatures (dbx) |   |   |
▶ Authorized TimeStamps (dbr) |   |   |
▶ OsRecovery Signatures (dbr) |   |   |

Press 'Yes' to proceed 'No' to cancel

Yes                                     No

elect Screen
elect Item
: Select
Change Opt.
F1: General Help
F2: Previous Values
F3: Optimized Defaults
F4: Save & Reset
ESC: Exit

Version 2.22.1293 Copyright (C) 2024AMI
    
```

BIOS-Eintrag	Optionen
Vendor Keys	Keine
Restore Factory Keys	Restore Factory Keys, siehe Kasten

7.5.1.3.2 Reset To Setup Mode

Aptio Setup - AMI
Security

<p>Vendor Keys Modified</p> <p>Factory Key Provision [Enabled]</p> <ul style="list-style-type: none"> ▶ Restore Factory Keys ▶ Reset To Setup Mode ▶ Enroll Efi Image ▶ Export Secure Boot variables <p>Secure Boot variable</p> <ul style="list-style-type: none"> ▶ Platform Key (PK) ▶ Key Exchange Keys (KEK) ▶ Authorized Signatures (db) ▶ Forbidden Signatures (dbx) ▶ Authorized TimeStamps (dbt) ▶ OsRecovery Signatures (dbr) 	<p style="text-align: center;">Reset To Setup Mode</p> <p style="text-align: center;">Deleting all variables will reset the System to Setup Mode Do you want to proceed?</p> <hr/> <p style="text-align: center;">Yes No</p>	<p>Delete all Secure Boot key databases from NVRAM</p> <hr/> <p>elect Screen elect Item : Select Change Opt. eneral Help</p> <p>F2: Previous Values F3: Optimized Defaults F4: Save & Reset ESC: Exit</p>
---	---	---

Version 2.22.1293 Copyright (C) 2024 AMI

BIOS-Eintrag	Optionen
Vendor Keys	Keine
Reset To Setup Mode	Reset To Setup Mode, siehe Kasten

7.5.1.3.3 Enroll Efi Image

Aptio Setup - AMI
Security

<p>Vendor Keys Modified</p> <p>Factory Key Provision [Enabled]</p> <ul style="list-style-type: none"> ▶ Restore Factory Keys ▶ Reset To Setup Mode ▶ Enroll Efi Image ▶ Export Secure Boot variables <table style="width: 100%; border-collapse: collapse;"> <thead> <tr> <th style="text-align: left;">Secure Boot variable</th> <th style="text-align: left;">Size</th> <th style="text-align: left;">Keys</th> <th style="text-align: left;">Key Source</th> </tr> </thead> <tbody> <tr> <td>▶ Platform Key (PK)</td> <td>8</td> <td></td> <td>File System</td> </tr> <tr> <td>▶ Key Exchange Keys (KEK)</td> <td>15</td> <td></td> <td></td> </tr> <tr> <td>▶ Authorized Signatures (db)</td> <td>31</td> <td colspan="2" style="border: 1px solid black; text-align: center;">No Valid File System Available</td> </tr> <tr> <td>▶ Forbidden Signatures (dbx)</td> <td>178</td> <td></td> <td></td> </tr> <tr> <td>▶ Authorized TimeStamps (dbt)</td> <td></td> <td></td> <td></td> </tr> <tr> <td>▶ OsRecovery Signatures (dbr)</td> <td></td> <td></td> <td></td> </tr> </tbody> </table>	Secure Boot variable	Size	Keys	Key Source	▶ Platform Key (PK)	8		File System	▶ Key Exchange Keys (KEK)	15			▶ Authorized Signatures (db)	31	No Valid File System Available		▶ Forbidden Signatures (dbx)	178			▶ Authorized TimeStamps (dbt)				▶ OsRecovery Signatures (dbr)				<p>Allow Efi image to run in Secure Boot mode. Enroll SHA256 Hash certificate of a PE image into Authorized Signature Database (db)</p> <hr/> <p>: Select Screen : Select Item ter: Select -: Change Opt. F1: General Help F2: Previous Values F3: Optimized Defaults F4: Save & Reset ESC: Exit</p>
Secure Boot variable	Size	Keys	Key Source																										
▶ Platform Key (PK)	8		File System																										
▶ Key Exchange Keys (KEK)	15																												
▶ Authorized Signatures (db)	31	No Valid File System Available																											
▶ Forbidden Signatures (dbx)	178																												
▶ Authorized TimeStamps (dbt)																													
▶ OsRecovery Signatures (dbr)																													

Version 2.22.1293 Copyright (C) 2024 AMI

BIOS-Eintrag	Optionen
Vendor Keys	Keine
Enroll Efi Image	File System, siehe Kasten

7.5.1.3.4 Export Secure Boot variables

Aptio Setup - AMI
Security

<p>Vendor Keys Modified</p> <p>Factory Key Provision [Disabled]</p> <ul style="list-style-type: none"> ▶ Restore Factory Keys ▶ Reset To Setup Mode ▶ Enroll Efi Image ▶ Export Secure Boot variables <table style="width: 100%; border-collapse: collapse;"> <thead> <tr> <th style="text-align: left;">Secure Boot variable</th> <th style="text-align: left;">Size</th> <th style="text-align: left;">Keys</th> <th style="text-align: left;">Key Source</th> </tr> </thead> <tbody> <tr> <td>▶ Platform Key (PK)</td> <td>8</td> <td></td> <td>File System</td> </tr> <tr> <td>▶ Key Exchange Keys (KEK)</td> <td>15</td> <td></td> <td></td> </tr> <tr> <td>▶ Authorized Signatures (db)</td> <td>31</td> <td colspan="2" style="border: 1px solid black; text-align: center;">No Valid File System Available</td> </tr> <tr> <td>▶ Forbidden Signatures (dbx)</td> <td>178</td> <td></td> <td></td> </tr> <tr> <td>▶ Authorized TimeStamps (dbt)</td> <td></td> <td></td> <td></td> </tr> <tr> <td>▶ OsRecovery Signatures (dbr)</td> <td></td> <td></td> <td></td> </tr> </tbody> </table>	Secure Boot variable	Size	Keys	Key Source	▶ Platform Key (PK)	8		File System	▶ Key Exchange Keys (KEK)	15			▶ Authorized Signatures (db)	31	No Valid File System Available		▶ Forbidden Signatures (dbx)	178			▶ Authorized TimeStamps (dbt)				▶ OsRecovery Signatures (dbr)				<p>Save NVRAM content of Secure Boot variable to a file</p> <hr/> <p>: Select Screen : Select Item ter: Select -: Change Opt. F1: General Help F2: Previous Values F3: Optimized Defaults F4: Save & Reset ESC: Exit</p>
Secure Boot variable	Size	Keys	Key Source																										
▶ Platform Key (PK)	8		File System																										
▶ Key Exchange Keys (KEK)	15																												
▶ Authorized Signatures (db)	31	No Valid File System Available																											
▶ Forbidden Signatures (dbx)	178																												
▶ Authorized TimeStamps (dbt)																													
▶ OsRecovery Signatures (dbr)																													

Version 2.22.1293 Copyright (C) 2024 AMI

BIOS-Eintrag	Optionen
Vendor Keys	Keine
Export Secure Boot variables	File System, siehe Kasten

7.5.1.3.5 Platform Key (PK)

Aptio Setup - AMI
Security

<p>Vendor Keys</p> <p>Factory Key Provision [Disabled]</p> <ul style="list-style-type: none"> ▶ Restore Factory Keys ▶ Reset To Setup Mode ▶ Enroll Efi Image ▶ Export Secure Boot variables <p>Secure Boot variable</p> <ul style="list-style-type: none"> ▶ Platform Key (PK) ▶ Key Exchange Keys (KEK) ▶ Authorized Signatures (db) ▶ Forbidden Signatures (dbx) 1 ▶ Authorized TimeStamps (dbt) ▶ OsRecovery Signatures (dbr) 	<p>Modified</p> <p>[Disabled]</p> <div style="border: 1px solid black; padding: 5px; margin: 10px auto; width: 80%;"> <p>Platform Key (PK)</p> <hr/> <p>Details</p> <p>Export</p> <p>Update</p> <p>Delete</p> </div>	<p>Enroll Factory Defaults or load certificates from a file:</p> <ol style="list-style-type: none"> 1.Public Key Certificate: <ol style="list-style-type: none"> a)EFI_SIGNATURE_LIST b)EFI_CERT_X509 (DER) c)EFI_CERT_RSA2048 (bin) d)EFI_CERT_SHAXXX 2.Authenticated UEFI Variable 3.EFI PE/COFF Image(SHA256) <p>Key Source: Factory,Modified,Mixed</p> <hr/> <p>←: Select Screen ↑↓: Select Item Enter: Select +/-: Change Opt. F1: General Help F2: Previous Values F3: Optimized Defaults F4: Save & Reset ESC: Exit</p>
---	--	--

Version 2.22.1293 Copyright (C) 2024 AMI

BIOS-Eintrag	Optionen
Vendor Keys	Keine
Platform Key (PK)	Platform Key (PK), siehe Kasten

7.5.1.3.6 Key Exchange Keys

Aptio Setup - AMI
Security

<p>Vendor Keys Modified</p> <p>Factory Key Provision [Disabled]</p> <ul style="list-style-type: none"> ▶ Restore Factory Keys ▶ Reset To Setup Mode ▶ Enroll Efi Image ▶ Export Secure Boot variables <p>Secure Boot variable</p> <ul style="list-style-type: none"> ▶ Platform Key (PK) ▶ Key Exchange Keys (KEK) 1 ▶ Authorized Signatures (db) ▶ Forbidden Signatures (dbx) ▶ Authorized TimeStamps (dbt) ▶ OsRecovery Signatures (dbr) 	<p style="text-align: center;">Key Exchange Keys (KEK)</p> <hr/> <p>Details</p> <p>Export</p> <p>Update</p> <p>Append</p> <p>Delete</p>	<p>Enroll Factory Defaults or load certificates from a file:</p> <ol style="list-style-type: none"> 1.Public Key Certificate: <ol style="list-style-type: none"> a)EFI_SIGNATURE_LIST b)EFI_CERT_X509 (DER) c)EFI_CERT_RSA2048 (bin) d)EFI_CERT_SHAXXX 2.Authenticated UEFI Variable 3.EFI PE/COFF Image(SHA256) <p>Key Source: Factory,Modified,Mixed</p> <hr/> <p>←: Select Screen ↓↑: Select Item Enter: Select +/-: Change Opt. F1: General Help F2: Previous Values F3: Optimized Defaults F4: Save & Reset ESC: Exit</p>
---	---	--

Version 2.22.1293 Copyright (C) 2024 AMI

BIOS-Eintrag	Optionen
Vendor Keys	Keine
Key Exchange Keys	Key Exchange Keys, siehe Kasten

7.5.1.3.7 Authorized Signatures

Aptio Setup - AMI
Security

<p>Vendor Keys Modified</p> <p>Factory Key Provision [Disabled]</p> <ul style="list-style-type: none"> ▶ Restore Factory Keys ▶ Reset To Setup Mode ▶ Enroll Efi Image ▶ Export Secure Boot variables <p>Secure Boot variable</p> <ul style="list-style-type: none"> ▶ Platform Key (PK) ▶ Key Exchange Keys (KEK) ▶ Authorized Signatures (db) ▶ Forbidden Signatures (dbx) 1 ▶ Authorized TimeStamps (dbt) ▶ OsRecovery Signatures (dbr) 	<p style="text-align: center;">Authorized Signatures (db)</p> <hr/> <p>Details</p> <p>Export</p> <p>Update</p> <p>Append</p> <p>Delete</p>	<p>Enroll Factory Defaults or load certificates from a file:</p> <ol style="list-style-type: none"> 1.Public Key Certificate: <ol style="list-style-type: none"> a)EFI_SIGNATURE_LIST b)EFI_CERT_X509 (DER) c)EFI_CERT_RSA2048 (bin) d)EFI_CERT_SHAXXX 2.Authenticated UEFI Variable 3.EFI PE/COFF Image(SHA256) <p>Key Source: Factory,Modified,Mixed</p> <hr/> <p>←: Select Screen ↑↓: Select Item Enter: Select +/-: Change Opt. F1: General Help F2: Previous Values F3: Optimized Defaults F4: Save & Reset ESC: Exit</p>
--	--	--

Version 2.22.1293 Copyright (C) 2024 AMI

BIOS-Eintrag	Optionen
Vendor Keys	Keine
Authorized Signatures	Authorized Signatures, siehe Kasten

7.5.1.3.8 Forbidden Signatures

Aptio Setup - AMI
Security

<p>Vendor Keys Modified</p> <p>Factory Key Provision [Disabled]</p> <ul style="list-style-type: none"> ▶ Restore Factory Keys ▶ Reset To Setup Mode ▶ Enroll Efi Image ▶ Export Secure Boot variables <p>Secure Boot variable</p> <ul style="list-style-type: none"> ▶ Platform Key (PK) ▶ Key Exchange Keys (KEK) ▶ Authorized Signatures (db) ▶ Forbidden Signatures (dbx) 1 ▶ Authorized TimeStamps (dbt) ▶ OsRecovery Signatures (dbr) 	<p style="text-align: center;">Forbidden Signatures (dbx)</p> <hr/> <p>Details</p> <p>Export</p> <p>Update</p> <p>Append</p> <p>Delete</p>	<p>Enroll Factory Defaults or load certificates from a file:</p> <ol style="list-style-type: none"> 1.Public Key Certificate: <ol style="list-style-type: none"> a)EFI_SIGNATURE_LIST b)EFI_CERT_X509 (DER) c)EFI_CERT_RSA2048 (bin) d)EFI_CERT_SHAXXX 2.Authenticated UEFI Variable 3.EFI PE/COFF Image(SHA256) <p>Key Source: Factory,Modified,Mixed</p> <hr/> <p>←: Select Screen ↑↓: Select Item Enter: Select +/-: Change Opt. F1: General Help F2: Previous Values F3: Optimized Defaults F4: Save & Reset ESC: Exit</p>
--	--	--

Version 2.22.1293 Copyright (C) 2024 AMI

BIOS-Eintrag	Optionen
Vendor Keys	Keine
Forbidden Signatures	Forbidden Signatures, siehe Kasten

7.5.1.3.9 Authorized TimeStamps

Aptio Setup - AMI
Security

<p>Vendor Keys Modified</p> <p>Factory Key Provision [Disabled]</p> <ul style="list-style-type: none"> ▶ Restore Factory Keys ▶ Reset To Setup Mode ▶ Enroll Efi Image ▶ Export Secure Boot variables <p>Secure Boot variable</p> <ul style="list-style-type: none"> ▶ Platform Key (PK) ▶ Key Exchange Keys (KEK) ▶ Authorized Signatures (db) ▶ Forbidden Signatures (dbx) 1 ▶ Authorized TimeStamps (dbt) ▶ OsRecovery Signatures (dbr) 	<div style="border: 1px solid black; padding: 5px; margin-bottom: 5px;"> <p style="text-align: center;">Authorized TimeStamps (dbt)</p> <hr/> <p style="text-align: center;">Update Append</p> </div> <p style="text-align: center;">0 0 No Keys</p>	<p>Enroll Factory Defaults or load certificates from a file:</p> <ol style="list-style-type: none"> 1.Public Key Certificate: <ol style="list-style-type: none"> a)EFI_SIGNATURE_LIST b)EFI_CERT_X509 (DER) c)EFI_CERT_RSA2048 (bin) d)EFI_CERT_SHAXXX 2.Authenticated UEFI Variable 3.EFI PE/COFF Image(SHA256) <p>Key Source: Factory,Modified,Mixed</p> <hr/> <p>←: Select Screen ↑↓: Select Item Enter: Select +/-: Change Opt. F1: General Help F2: Previous Values F3: Optimized Defaults F4: Save & Reset ESC: Exit</p>
--	--	--

Version 2.22.1293 Copyright (C) 2024 AMI

BIOS-Eintrag	Optionen
Vendor Keys	Keine
Authorized TimeStamps	Authorized TimeStamps, siehe Kasten

7.5.1.3.10 OsRecovery Signatures

Aptio Setup - AMI
Security

<p>Vendor Keys Modified</p> <p>Factory Key Provision [Disabled]</p> <ul style="list-style-type: none"> ▶ Restore Factory Keys ▶ Reset To Setup Mode ▶ Enroll Efi Image ▶ Export Secure Boot variables <p>Secure Boot variable</p> <ul style="list-style-type: none"> ▶ Platform Key (PK) ▶ Key Exchange Keys (KEK) ▶ Authorized Signatures (db) ▶ Forbidden Signatures (dbx) ▶ Authorized TimeStamps (dbt) ▶ OsRecovery Signatures (dbr) 	<div style="border: 1px solid black; padding: 5px; margin-bottom: 5px;"> <p style="text-align: center;">OsRecovery Signatures (dbr)</p> <hr/> <p style="text-align: center;">Update Append</p> </div> <p style="text-align: center;">0 0 No Keys</p>	<p>Enroll Factory Defaults or load certificates from a file:</p> <p>1.Public Key Certificate:</p> <ul style="list-style-type: none"> a)EFI_SIGNATURE_LIST b)EFI_CERT_X509 (DER) c)EFI_CERT_RSA2048 (bin) d)EFI_CERT_SHAXXX <p>2.Authenticated UEFI Variable</p> <p>3.EFI PE/COFF Image(SHA256)</p> <p>Key Source: Factory,Modified,Mixed</p> <hr/> <p>←: Select Screen ↑↓: Select Item Enter: Select +/-: Change Opt. F1: General Help F2: Previous Values F3: Optimized Defaults F4: Save & Reset ESC: Exit</p>
--	--	--

Version 2.22.1293 Copyright (C) 2024 AMI

BIOS-Eintrag	Optionen
Vendor Keys	Keine
OsRecovery Signatures	OsRecovery Signatures, siehe Kasten

7.6 Boot

Aptio Setup – AMI

Main Advanced Chipset Security **Boot** Save & Exit

<p>Boot Configuration</p> <p>Setup Prompt Timeout 1</p> <p>Bootup NumLock State [Off]</p> <p>Quiet Boot [Enabled]</p> <p> </p> <p>Driver Option Proirities</p> <p> </p> <p>FIXED BOOT ORDER Priorities</p> <p>Boot Option #1 [Service Stick]</p> <p>Boot Option #2 [CFast]</p> <p>Boot Option #3 [SSD]</p> <p>Boot Option #4 [HDD]</p> <p>Boot Option #5 [CD/DVD]</p> <p>Boot Option #6 [USB Stick]</p> <p>Boot Option #7 [USB Floppy]</p> <p>Boot Option #8 [USB Hard Disk]</p> <p>Boot Option #9 [USB CD/DVD]</p> <p>Boot Option #10 [Network]</p> <p>Boot Option #11 [USB Lan]</p> <p>► Advanced Fixed Boot Order Parameters</p>	<p>Number of seconds to wait for setup activation key. 65535 (0xFFFF) means indefinite waiting.</p> <p> </p> <p>←: Select Screen</p> <p>↑↓: Select Item</p> <p>Enter: Select</p> <p>+/-: Change Opt.</p> <p>F1: General Help</p> <p>F2: Previous Values</p> <p>F3: Optimized Defaults</p> <p>F4: Save & Reset</p> <p>ESC: Exit</p>
---	--

Version 2.22.1293 Copyright (C) 2024 AMI

BIOS-Eintrag	Optionen
Boot Configuration	
Setup Prompt Timeout	Keine
Bootup NumLok State	On / Off
Quiet Boot	Enabled / Disabled
Driver Option Priorities	
Fixed Boot Order Priorities	
Boot Option #1 - 11	Hier kann die Reihenfolge der zu verwendenden Bootmedien gesetzt werden.
Advanced Fixed Boot Order Parameters	Untermenü siehe: Advanced Fixed Boot Order Parameters [► 112]

7.6.1 Advanced Fixed Boot Order Parameters

Aptio Setup - AMI		
Boot		
Min. CFAST capacity (GB)	0	Lower capacity limit for boot group CFAST in GB
Max. CFAST capacity (GB)	119	
Min. SSD capacity (GB)	119	
Max. SSD capacity (GB)	481	
Min. HDD capacity (GB)	481	
Max. HDD capacity (GB)	8000000	
Max. USB Stick capacity (GB)	64	
UEFI BDS Boot Filter	[Enabled]	
Re-enable UEFI Disks	[Enabled]	
BootDeviceDef Version 3(11/22/2018)		
Version 2.22.1293 Copyright (C) 2024 AMI		

BIOS-Eintrag	Optionen
Min. CFAST capacity (GB)	Keine
Max. CFAST capacity (GB)	Keine
Min. SSD capacity (GB)	Keine
Max. SSD capacity (GB)	Keine
Min. HDD capacity (GB)	Keine
Max. HDD capacity (GB)	Keine
Max. USB Stick capacity (GB)	Keine
UEFI BDS Boot Filter	Enabled / Disabled
Re-enable UEFI Disks	Enabled / Disabled
BootDeviceDef Version 3(11/22/2018)	

7.7 Save & Exit

Aptio Setup - AMI

Main Advanced Chipset Security Boot **Save & Exit**

Save Changes and Exit Discard Changes and Exit Save Changes Discard Changes and Reset Save Changes Discard Changes Default Options Restore Defaults Save as User Defaults Restore User Defaults Boot Override Launch EFI Shell from filesystem device	Exit system setup after saving the changes. →: Select Screen ↑↓: Select Item Enter: Select +/-: Change Opt. F1: General Help F2: Previous Values F3: Optimized Defaults F4: Save & Reset ESC: Exit
--	---

Version 2.22.1293 Copyright (C) 2024 AMI

BIOS-Eintrag	Optionen
Save Options	
Save Changes and Exit	Eingabetaste drücken
Discard Changes and Exit	Eingabetaste drücken
Save Changes	Eingabetaste drücken
Discard Changes and Reset	Eingabetaste drücken
Save Changes	Eingabetaste drücken
Discard Changes	Eingabetaste drücken
Default Options	
Restore Optimized Defaults	Eingabetaste drücken
Save as User Defaults	Eingabetaste drücken
Restore as User Defaults	Eingabetaste drücken
Boot Override	
Launch EFI Shell from filesystem device	Eingabetaste drücken

8 Mechanische Zeichnungen

8.1 Leiterplatte: Abmessungen

All dimensions are in mm



Abb. 25: CB1076 MZ

8.2 Leiterplatte: Montage-Bohrungen

Mounting Holes H1-H9: Inner=3,962 Outer=10,16
All dimensions are in mm



Abb. 26: CB1076 MZ-MH

9 Technische Daten

9.1 Elektrische Daten

Spannungsversorgung	
Board	24 VDC Netzteil (+20 % / - 15 %)
RTC	≥3 A
Leistung	
Trafo	95 W Dauerlast 150 W Peaklast
Stromverbrauch	
RTC	≤ 10 μm

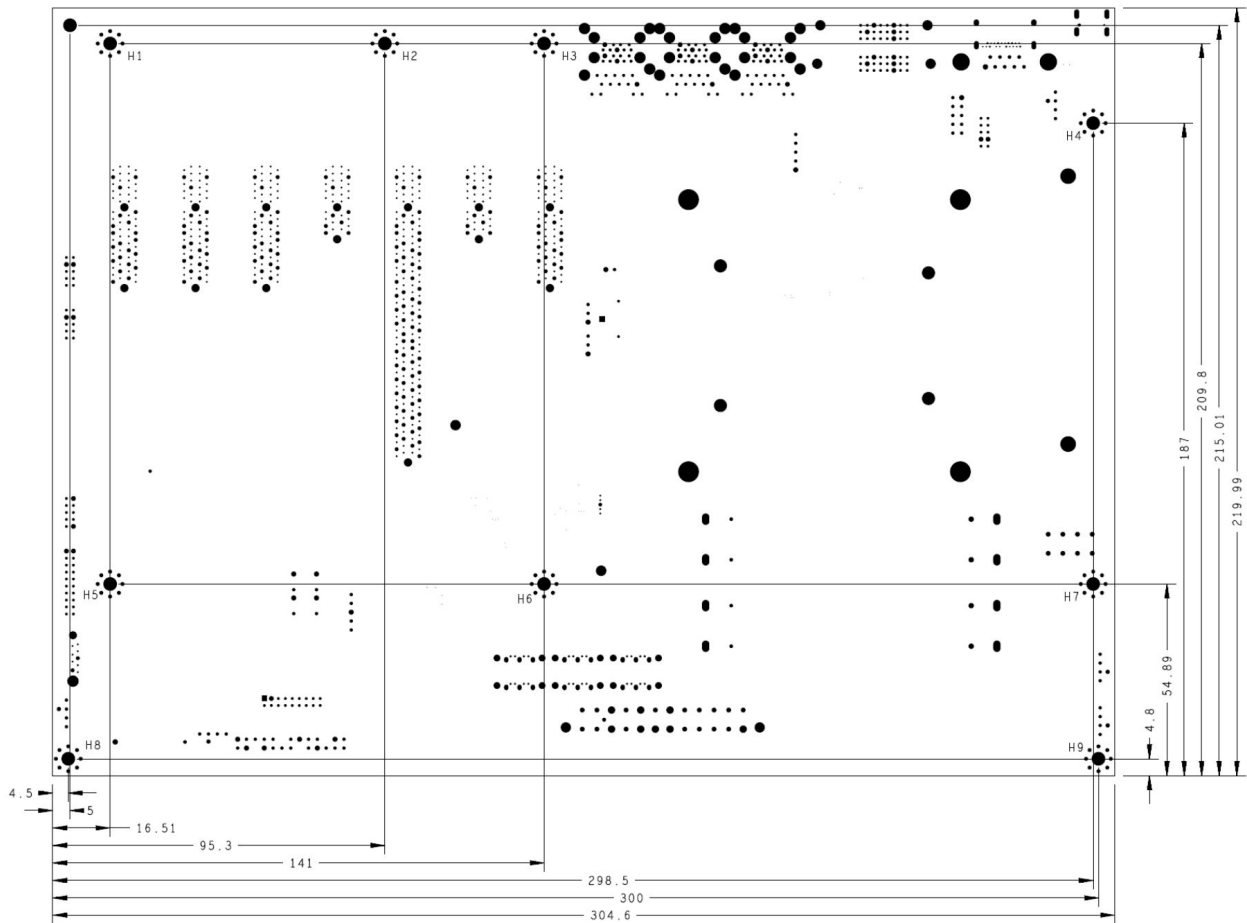
9.2 Umgebungsbedingungen

Temperaturbereich	
Operating	0 °C bis +60 °C (erweiterter Temperaturbereich auf Anfrage)
Lagerung	-25 °C bis +85 °C
Versand	-25 °C bis +85 °C, für verpackte Boards
Temperaturänderungen	
Operating	0,5 °C pro Minute, 7,5 °C in 30 Minuten
Lagerung	1,0 °C pro Minute
Versand	1,0 °C pro Minute, für verpackte Boards
Relative Luftfeuchte	
Operating	5 % bis 85 % (nicht kondensierend)
Lagerung	5 % bis 95 % (nicht kondensierend)
Versand	5 % bis 100 % (nicht kondensierend), für verpackte Boards
Stoß	
Operating	150 m/s ² , 6 ms
Lagerung	400 m/s ² , 6 ms
Versand	400 m/s ² , 6 ms, für verpackte Boards
Vibration	
Operating	10 bis 58 Hz, 0,075 mm Amplitude
Lagerung	5 bis 9 Hz, 3,5 mm Amplitude 9 bis 500 Hz, 10 m/s ²
Versand	5 bis 9 Hz, 3,5 mm Amplitude 9 bis 500 Hz, 10 m/s ² , für verpackte Boards

i Hinweis zu Stoß- und Vibrationsfestigkeit

Die Angaben zu Stoß- und Vibrationsfestigkeit beziehen sich auf das reine Motherboard ohne Kühlkörper, Speicherriegel, Verkabelungen usw.

9.3 Thermische Spezifikationen

Das Board ist spezifiziert für einen Umgebungstemperaturbereich von 0 °C bis +60 °C (erweiterter Temperaturbereich auf Anfrage). Zusätzlich muss darauf geachtet werden, dass die Temperatur des Prozessor-Dies 100 °C nicht überschreitet. Hierfür muss ein geeignetes Kühlkonzept realisiert werden, das sich an der maximalen Leistungsaufnahme des Prozessors/Chipsatzes orientiert. Zu beachten ist dabei auch, dass eventuell vorhandene Controller im Kühlkonzept Berücksichtigung finden. Die Leistungsaufnahme dieser Bausteine liegt unter Umständen in der gleichen Größenordnung wie die Leistungsaufnahme des Prozessors. Das Board ist durch geeignete Bohrungen für den Einsatz moderner Kühl-Lösungen vorbereitet. Wir haben eine Reihe von kompatiblen Kühl-Komponenten im Programm. Ihr Distributor berät Sie gerne bei der Auswahl geeigneter Lösungen.

HINWEIS

Überschreiten der maximalen Die-Temperatur verhindern!

Es liegt im Verantwortungsbereich des Endkunden, dass die Die-Temperatur des Prozessors 100 °C nicht überschreitet! Eine dauerhafte Überhitzung kann das Board zerstören!

Für den Fall, dass die Temperatur 100 °C überschreitet, muss die Umgebungstemperatur reduziert werden. Unter Umständen muss für eine ausreichende Luftzirkulation Sorge getragen werden.

10 Anhang I: Post-Codes

Während der Bootphase generiert das BIOS eine Reihe von Statusmeldungen (sog. „POST-Codes“), die mit Hilfe eines geeigneten Lesegerätes (POST-Code-Karte) ausgegeben werden können. Die Bedeutung der POST-Codes wird in dem Dokument „Aptio™ 5.x Status Codes“ von American Megatrends® erläutert, das auf der Webseite <http://www.ami.com> erhältlich ist. Zusätzlich werden die folgenden OEM-POST-Codes ausgegeben:

Code	Beschreibung
87h	BIOS-API gestartet
88h	PCA9535 gestartet
89h	PWRCTRL-Firmware gestartet

11 Anhang II: Ressourcen

11.1 Interrupt

Die verwendeten Ressourcen sind abhängig von der Setup-Einstellung. Die aufgeführten Interrupts und deren Benutzung sind durch die AT-Kompatibilität gegeben. Wenn Interrupts exklusiv auf der ISA-Seite zur Verfügung stehen müssen, sind diese durch das BIOS-Setup zu reservieren. Auf der PCI-Seite ist die Exklusivität nicht gegeben und auch nicht möglich.

11.2 PCI-Devices

Die hier aufgeführten PCI-Devices sind alle auf dem Board vorhandenen, inklusive der, die durch das BIOS erkannt und konfiguriert werden. Durch Setup-Einstellungen des BIOS kann es vorkommen, dass verschiedene PCI-Devices oder Funktionen von Devices nicht aktiviert sind. Wenn Devices deaktiviert werden, kann sich dadurch bei anderen Devices die Bus-Nummer ändern.

Bus	Dev.	Fkt.	Controller / Slot
00	00	00	Host Bridge ID 3E30
00	01	00	PCI-to- PCI Bridge ID1901
00	01	01	PCI-to- PCI Bridge ID1905
00	01	02	PCI-to- PCI Bridge ID1909
00	02	00	VGA Controller ID3E98
00	08	00	System Device ID1911
00	12	00	Data Acquisition/Signal Processing Controller ID A379
00	14	00	XHCI USB Controller ID A36D
00	14	02	RAM Controller ID A36F
00	16	00	Communication Device ID A360
00	16	03	Serial Device ID A363
00	17	00	RAID Controller ID 2822
00	1D	00	PCI-to-PCI Bridge ID A330
00	1D	04	PCI-to-PCI Bridge ID A334
00	1F	02	ISA Bridge ID A306
00	1F	03	HD Audio Device ID A348
00	1F	04	SMBus Controller ID A323
00	1F	05	Controller ID A324
00	1F	06	Ethernet Controller ID 15BB
01	00	00	Ethernet Controller (PCIE) ID 1533
02	00	00	Ethernet Controller (PCIE) ID 1533
03	00	00	Ethernet Controller (PCIE) ID 1533

11.3 SMB-Devices

Die folgende Tabelle listet die reservierten SM-Bus-Device-Adressen in 8-Bit-Schreibweise auf.

HINWEIS

Diese Adressbereiche dürfen auch dann nicht von externen Geräten benutzt werden, wenn die in der Tabelle zugeordnete Komponente auf dem Motherboard gar nicht vorhanden ist.

Adresse	Funktion
34-35	API-Zugriff auf Netzteil
36-39	Reserviert
5C-5D	NCT7491
60-6F	Reserviert für DDR4
70-73	POST-Code Output
88-89	Vom BIOS definierte Slave-Adresse
A0-A7	Reserviert für DDR4
B0-B3	Power-Controller (Zugriff über BIOS-API)
B8-BB	Power-Controller (Zugriff über BIOS-API)

12 Support und Service

Beckhoff und seine weltweiten Partnerfirmen bieten einen umfassenden Support und Service, der eine schnelle und kompetente Unterstützung bei allen Fragen zu Beckhoff Produkten und Systemlösungen zur Verfügung stellt.

Downloadfinder

Unser [Downloadfinder](#) beinhaltet alle Dateien, die wir Ihnen zum Herunterladen anbieten. Sie finden dort Applikationsberichte, technische Dokumentationen, technische Zeichnungen, Konfigurationsdateien und vieles mehr.

Die Downloads sind in verschiedenen Formaten erhältlich.

Beckhoff Niederlassungen und Vertretungen

Wenden Sie sich bitte an Ihre Beckhoff Niederlassung oder Ihre Vertretung für den [lokalen Support und Service](#) zu Beckhoff Produkten!

Die Adressen der weltweiten Beckhoff Niederlassungen und Vertretungen entnehmen Sie bitte unserer Internetseite: www.beckhoff.com

Dort finden Sie auch weitere Dokumentationen zu Beckhoff Komponenten.

Beckhoff Support

Der Support bietet Ihnen einen umfangreichen technischen Support, der Sie nicht nur bei dem Einsatz einzelner Beckhoff Produkte, sondern auch bei weiteren umfassenden Dienstleistungen unterstützt:

- Support
- Planung, Programmierung und Inbetriebnahme komplexer Automatisierungssysteme
- umfangreiches Schulungsprogramm für Beckhoff Systemkomponenten

Hotline: +49 5246 963-157

E-Mail: support@beckhoff.com

Beckhoff Service

Das Beckhoff Service-Center unterstützt Sie rund um den After-Sales-Service:

- Vor-Ort-Service
- Reparaturservice
- Ersatzteilservice
- Hotline-Service

Hotline: +49 5246 963-460

E-Mail: service@beckhoff.com

Beckhoff Unternehmenszentrale

Beckhoff Automation GmbH & Co. KG

Hülshorstweg 20
33415 Verl
Deutschland

Telefon: +49 5246 963-0

E-Mail: info@beckhoff.com

Internet: www.beckhoff.com

Trademark statements

Beckhoff®, ATRO®, EtherCAT®, EtherCAT G®, EtherCAT G10®, EtherCAT P®, MX-System®, Safety over EtherCAT®, TC/BSD®, TwinCAT®, TwinCAT/BSD®, TwinSAFE®, XFC®, XPlanar® and XTS® are registered and licensed trademarks of Beckhoff Automation GmbH.

Third-party trademark statements

The Bluetooth® word mark and logos are registered trademarks owned by Bluetooth SIG, Inc and any use of such marks by Beckhoff is under license.

CFast is a registered trademark of CompactFlash Association.

Excel, IntelliSense, Microsoft, Microsoft Azure, Microsoft Edge, PowerShell, Visual Studio, Windows and Xbox are trademarks of the Microsoft group of companies.

Intel, the Intel logo, Intel Core, Xeon, Intel Atom, Celeron and Pentium are trademarks of Intel Corporation or its subsidiaries.

The NVM Express and NVMe word marks are registered and unregistered, trademarks and service marks of NVM Express, Inc. in the United States and other countries.

PCI Express®, PCIe®, PCI™ and PCI HOT PLUG™ are trademarks or registered trademarks and/or service marks of PCI-SIG.

Beckhoff Automation GmbH & Co. KG
Hülshorstweg 20
33415 Verl
Deutschland
Telefon: +49 5246 9630
info@beckhoff.com
www.beckhoff.com