

Hardware Documentation

CX9000 / CX9010

Embedded PC

Version: 2.6
Date: 2015-07-10

BECKHOFF

Table of contents

1 Foreword	5
1.1 Notes on the documentation	5
1.2 Safety instructions	6
1.3 Documentation Issue Status	7
2 Product overview	8
2.1 Appropriate Use	8
2.2 Ethernet-Controller CX90x0	9
2.3 Basic modules	10
2.3.1 Technical data	11
2.3.2 Technical data	12
2.3.3 Technical data	13
2.3.4 Technical data	14
2.3.5 Configurations	15
2.3.6 Configurations	16
2.3.7 Connections	17
2.3.8 Battery compartment	20
2.3.9 CX90x0 : Dip switch settings	21
2.4 System interfaces	23
2.4.1 Technical Data	23
2.4.2 CX90x0-N010 connections	24
2.4.3 CX90x0-N030 connections	26
2.4.4 CX90x0-N031 connections	27
3 Transport	30
3.1 Unpacking, installation and transport	30
4 Assembly and connecting	31
4.1 Mechanical assembly	31
4.1.1 Dimensions	31
4.1.2 Mechanical assembly of the basic module	33
4.1.3 Mechanical installation of the UPS Module	34
4.2 Start-up procedure	37
4.2.1 Switching the PC on and off	37
5 Error handling and diagnostics	38
5.1 CPU basic module	38
5.1.1 LEDs Basic CPU-module (E-Bus)	38
5.1.2 LEDs Basic CPU-module (K-Bus)	38
5.1.3 Terminal Bus Analysis in PLC-Program	40
6 Decomissioning	42
6.1 Removal and disposal	42
7 Appendix	44
7.1 CX90x0 : Update Image	44
7.2 Accessories	57
7.3 Certifications	59
7.4 Support and Service	60

1 Foreword

1.1 Notes on the documentation

This description is only intended for the use of trained specialists in control and automation engineering who are familiar with the applicable national standards.

It is essential that the documentation and the following notes and explanations are followed when installing and commissioning the components.

It is the duty of the technical personnel to use the documentation published at the respective time of each installation and commissioning.

The responsible staff must ensure that the application or use of the products described satisfy all the requirements for safety, including all the relevant laws, regulations, guidelines and standards.

Disclaimer

The documentation has been prepared with care. The products described are, however, constantly under development.

We reserve the right to revise and change the documentation at any time and without prior announcement. No claims for the modification of products that have already been supplied may be made on the basis of the data, diagrams and descriptions in this documentation.

Trademarks

Beckhoff®, TwinCAT®, EtherCAT®, Safety over EtherCAT®, TwinSAFE®, XFC® and XTS® are registered trademarks of and licensed by Beckhoff Automation GmbH.

Other designations used in this publication may be trademarks whose use by third parties for their own purposes could violate the rights of the owners.

Patent Pending

The EtherCAT Technology is covered, including but not limited to the following patent applications and patents:

EP1590927, EP1789857, DE102004044764, DE102007017835

with corresponding applications or registrations in various other countries.

The TwinCAT Technology is covered, including but not limited to the following patent applications and patents:

EP0851348, US6167425 with corresponding applications or registrations in various other countries.

EtherCAT 

EtherCAT® is registered trademark and patented technology, licensed by Beckhoff Automation GmbH, Germany

Copyright

© Beckhoff Automation GmbH & Co. KG, Germany.

The reproduction, distribution and utilization of this document as well as the communication of its contents to others without express authorization are prohibited.

Offenders will be held liable for the payment of damages. All rights reserved in the event of the grant of a patent, utility model or design.

1.2 Safety instructions

Safety regulations

Please note the following safety instructions and explanations!
Product-specific safety instructions can be found on following pages or in the areas mounting, wiring, commissioning etc.

Exclusion of liability





All the components are supplied in particular hardware and software configurations appropriate for the application. Modifications to hardware or software configurations other than those described in the documentation are not permitted, and nullify the liability of Beckhoff Automation GmbH & Co. KG.

Personnel qualification

This description is only intended for trained specialists in control, automation and drive engineering who are familiar with the applicable national standards.

Description of symbols

In this documentation the following symbols are used with an accompanying safety instruction or note. The safety instructions must be read carefully and followed without fail!

 DANGER	<p>Serious risk of injury! Failure to follow the safety instructions associated with this symbol directly endangers the life and health of persons.</p>
 WARNING	<p>Risk of injury! Failure to follow the safety instructions associated with this symbol endangers the life and health of persons.</p>
 CAUTION	<p>Personal injuries! Failure to follow the safety instructions associated with this symbol can lead to injuries to persons.</p>
 Attention	<p>Damage to the environment or devices Failure to follow the instructions associated with this symbol can lead to damage to the environment or equipment.</p>
 Note	<p>Tip or pointer This symbol indicates information that contributes to better understanding.</p>

1.3 Documentation Issue Status

Version	Changes
2.6	annotations to battery recycling added
2.5	notes on image update renewed
2.4	system interfaces CX1200-xxxx removed
2.3	new installation positions are added
2.2	changes in names of system interfaces CX90x0-N070 and CX90x0-N080 inserted
2.1	notes on new system interfaces CX90x0-N070 and CX90x0-N080 added
2.0	notes on CX9010 added, notes on battery usage and update procedure changed
1.9	order information changed
1.8	notes on K-Bus diagnosis added
1.7	notes on USV and CF card handling added title picture changed
1.6	notes on image update via software added
1.5	cable length of DVI cable corrected,
1.4	consumption value for CX9000-A001 added
1.3	notes on dip switches and image update added
1.2	notes for CF-card added, errors in module numbers corrected
1.1	notes for system interface N010 added
1.0	revised version
0.0.1	preliminarily version

2 Product overview

2.1 Appropriate Use

The CX-System device series is a modular control system designed for top-hat rail installation. The system is scalable, so that the required modules can be assembled and installed in the control cabinet or terminal box as required.

Only switch the PC off after closing the software

Before the Embedded PC is switched off, the software currently running on it should be stopped properly in order to avoid data loss on the hard disk. Please read the section on “Switching off [▶ 37]”.

Switch off all system components and uncouple the Industrial PC from the system if the PC is not used for control purposes, e.g. during a function test.

System components that have been switched off must be secured against being switched on again.

The power supply unit of the Embedded PC requires a 24 V DC supply.



Parts under power

Do not exchange any parts when under power! When components are being fitted or removed, the supply voltage must be switched off.

Software knowledge



Attention

System malfunctions

Mandatory software knowledge! Every user must be familiar with any of the functions of the software installed on the PC that he can reach.

2.2 Ethernet-Controller CX90x0

With the Ethernet controller CX9000, Beckhoff presents a further extension of the family of CX-type embedded controllers. The CX90x0 is a compact, high-performance yet cost-effective PLC and motion controller for 30 mm DIN rail mounting. Within the Beckhoff control world it is positioned between the Bus Terminal Controller series BX and the Embedded PC CX1000. The main feature of this devices is an energy-saving 266 MHz or 533 MHz Intel® IXP420 CPU with XScale® technology that runs under the Microsoft Windows CE operating system. It thus offers adequate computing capacity even for complex automation tasks. The CX90x0 requires no external storage media – the device boots the operating system from the internal flash. Due to the low power consumption, within the specified operating range no fan is required. The CX90x0 therefore requires no rotating components. As usual for the CX series, the device features a modular mechanical design. In its basic configuration, the compact device only measures 58 x 100 x 91 mm.

EtherCAT as fast I/O-System / K-Bus as alternative I/O-System

The CX90x0 is available in two versions: with K-bus for direct connection of Bus Terminals, and as an E-bus version for direct connection of EtherCAT Terminals. In the basic configuration, two RJ 45 sockets that are internally connected to an integrated switch are available as interfaces. This simplifies wiring of several CX90x0 within a line topology. No separate switch hardware is required. The two externally accessible Ethernet ports are independent of the EtherCAT interface, which is served by a second MAC (media access controller) provided by the CPU.

Basic module and Systeminterfaces

Further interfaces may be added ex works as required: A screen display can be realized using a CX90x0-N001 device, i.e. a module combining DVI/ VGA + 2 x USB 2.0. The combination of DVI and USB enables all types of Beckhoff Control Panel with DVI/USB interface to be used. Touch functionality is connected via USB. As a further option, two RS232 modules or two RS422/RS485 modules can be configured as COM1 and COM2. All serial interfaces feature opto-decoupling. Mass storage in form of a Compact Flash card can be used via the CX90x0-A000 module, which offers physical storage capacity in the range of several gigabytes.

SPS, Motion Control and Visualization

Like for all Beckhoff controllers, TwinCAT is used for programming the CX90x0 as an automation device. The device itself contains the run-time environment for PLC and Motion Control. One of the two Ethernet interfaces is used as programming interface.

Software

Microsoft Windows CE enables the creation of fully graphic user programs, which are able to satisfy high expectations thanks to the graphics chip integrated in the CX90x0.

In summary, the CX90x0 is a compact Ethernet controller, which in combination with EtherCAT I/O allows very fast I/O control cycles. Windows CE and TwinCAT CE constitute the powerful software architecture for this controller.

2.3 Basic modules

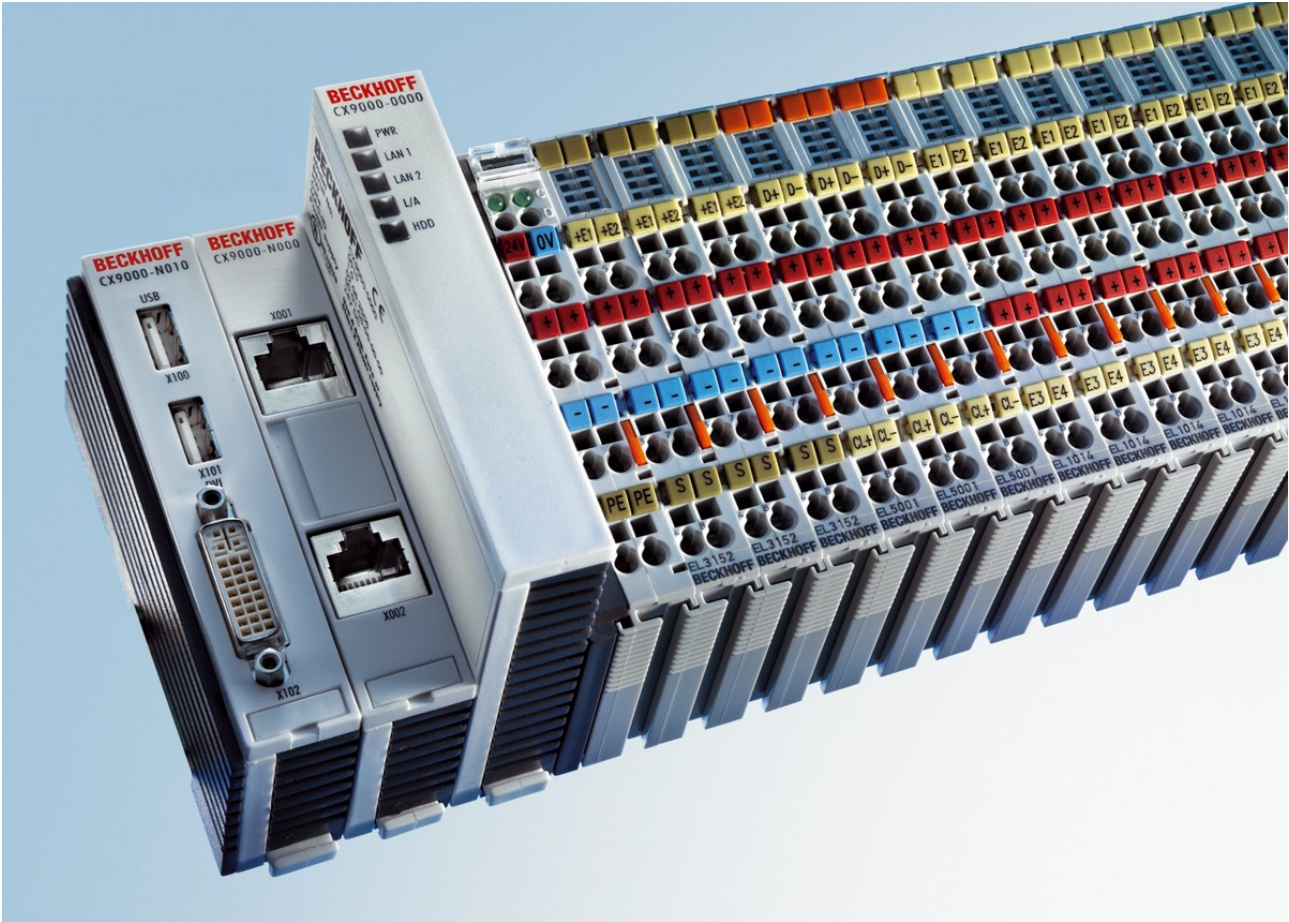

The CX90xx is a compact, top hat rail-mountable Ethernet Controller with direct connection to the Beckhoff I/O systems in IP 20. The CX90xx is available in two basic versions: one version for Bus Terminals with K-bus, the other one for EtherCAT Terminals with E-bus. The CX9000 comprises the CPU, the internal flash memory with two configuration options, the main memory (RAM) (available in two different sizes), and NOVRAM as non-volatile memory. In opposite to the CX9000 the CX9010 is only available with 32 MB flash memory, 128 MB main memory (RAM). Two Ethernet RJ 45 interfaces are also part of the basic configuration.

These interfaces are connected to an internal switch and offer a simple option for creating a line topology without the need for additional Ethernet switches. A memory medium in Compact Flash format I and II is available as an optional module (only in combination with system interface CX9010-N010). The operating system is Microsoft Windows CE. The TwinCAT automation software transforms a CX90xx system into powerful PLC and Motion Control system that can be operated with or without visualization.

Further system interfaces can be connected to the CPU module ex works. The CX90xx-N010 option can be connected to Beckhoff Control Panels or standard monitors with DVI or VGA input via the DVI and USB interfaces. Devices such as printer, scanner, mouse, keyboard, mass storage, CR-RW etc. can be connected via the USB2.0 interfaces. The module CX90xx-N030 offers two serial RS232 interfaces with a maximum transfer speed of 115 kbaud. These two interfaces can be implemented as RS422/RS485, in which case they are identified as CX90xx-N031.

2.3.1 Technical data

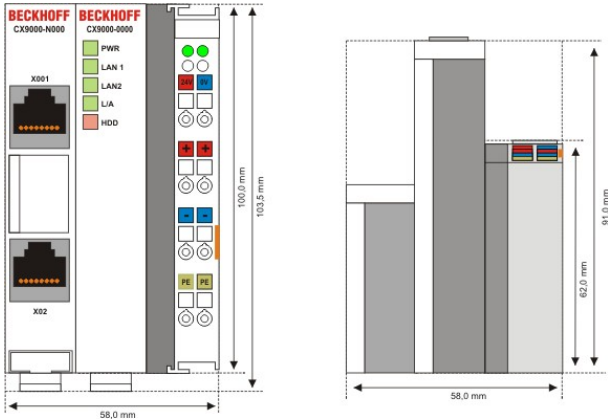

Technical data	CX9000-0000
Processor	Intel® IXP420 with XScale® Technology, 266-MHz clock rate
Internal flash memory	16 MByte Flash (internal, expandable up to 32 MByte)
Internal main memory	64 MByte RAM (internal, expandable up to 128 MByte)
interfaces	2 x RJ 45 (internal Switch), 10/100 MBit
Diagnostics LEDs	1 x Power, 2 x LAN, 1 x L/A, 1 x flash access
Clock	internal battery-backed clock for time and date
Operating system	Microsoft Windows CE
Control software	TwinCAT-CE-PLC-Runtime or TwinCAT-CE-NC-PTP-Runtime
Power supply	24 V _{DC} (-15%/+20%) To meet the UL requirements use a 4 A fuse or a power supply that has to satisfy <i>NEC class 2!</i>
Dielectric strength	500 V _{rms} (supply/internal electronics)
I/O connection	E-bus (EtherCAT Terminals)
NOVRAM	128 kByte
I/O-DPRAM	-
Power supply I/O terminals	2 A
Max. power loss	6 W (including CX9000-xxxx system interfaces)
Dimensions (W x H x D)	59 mm x 100 mm x 91 mm
weight	ca. 250 g
Operating / storage temperature	0° C ... +50° C / -25° C ... +85° C
Relative humidity	95% no condensation
Vibration/shock resistance	conforms to EN 60068-2-6 / EN 60068-2-27/29
EMC resistance burst/ ESD	conforms to EN 61000-6-2/EN 61000-6-4
Protection class	IP 20



2.3.2 Technical data

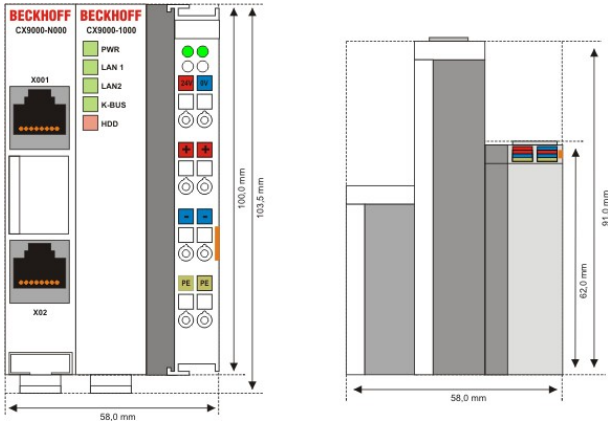

Technical data	CX9000-1000
Processor	Intel® IXP420 with XScale® Technology, 266-MHz clock rate
Internal flash memory	16 MByte Flash (internal, expandable up to 32 MByte)
Internal main memory	64 MByte RAM (internal, expandable up to 128 MByte)
interfaces	2 x RJ 45 (internal Switch), 10/100 MBit
Diagnostics LEDs	1 x Power, 2 x LAN, 1 x K-Bus, 1 x Flash-Zugriff
Clock	internal battery-backed clock for time and date
Operating system	Microsoft Windows CE
Control software	TwinCAT-CE-PLC-Runtime or TwinCAT-CE-NC-PTP-Runtime
Power supply	24 V _{DC} (-15%/+20%) To meet the UL requirements use a 4 A fuse or a power supply that has to satisfy <i>NEC class 2!</i>
Dielectric strength	500 V _{rms} (supply/internal electronics)
I/O connection	K-bus (Bus Terminals)
NOVRAM	128 kByte
I/O-DPRAM	4 kByte
Power supply I/O terminals	2 A
Max. power loss	6 W (including CX9000-xxxx system interfaces)
Dimensions (W x H x D)	59 mm x 100 mm x 91 mm
weight	ca. 250 g
Operating / storage temperature	0° C ... +50° C / -25° C ... +85° C
Relative humidity	95% no condensation
Vibration/shock resistance	conforms to EN 60068-2-6 / EN 60068-2-27/29
EMC resistance burst/ ESD	conforms to EN 61000-6-2/EN 61000-6-4
Protection class	IP 20



2.3.3 Technical data

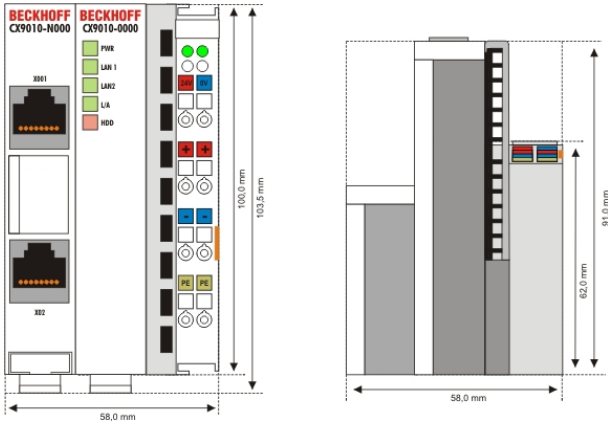

Technical data	CX9010-0000
Processor	Intel® IXP420 with XScale® Technology, 533-MHz clock rate
Internal flash memory	32 MByte Flash (internal)
Internal main memory	128 MByte RAM (internal)
interfaces	2 x RJ 45 (internal Switch), 10/100 MBit
Diagnostics LEDs	1 x Power, 2 x LAN, 1 x L/A, 1 x flash access
Clock	internal battery-backed clock for time and date
Operating system	Microsoft Windows CE
Control software	TwinCAT-CE-PLC-Runtime or TwinCAT-CE-NC-PTP-Runtime
Power supply	24 V _{DC} (-15%/+20%) To meet the UL requirements use a 4 A fuse or a power supply that has to satisfy <i>NEC class 2!</i>
Dielectric strength	500 V _{rms} (supply/internal electronics)
I/O connection	E-bus (EtherCAT Terminals)
NOVRAM	128 kByte
I/O-DPRAM	-
Power supply I/O terminals	2 A
Max. power loss	6.5 W (including CX9010-xxxx system interfaces)
Dimensions (W x H x D)	59 mm x 100 mm x 91 mm
weight	ca. 250 g
Operating / storage temperature	0° C ... +50° C / -25° C ... +85° C
Relative humidity	95% no condensation
Vibration/shock resistance	conforms to EN 60068-2-6 / EN 60068-2-27/29
EMC resistance burst/ESD	conforms to EN 61000-6-2/EN 61000-6-4
Protection class	IP 20



2.3.4 Technical data

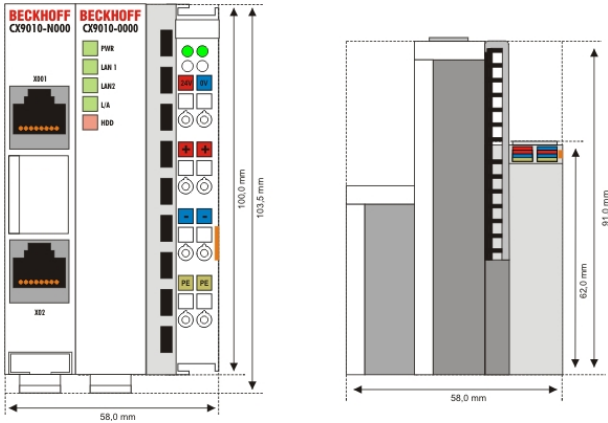

Technical data	CX9010-1000
Processor	Intel® IXP420 with XScale® Technology, 533-MHz clock rate
Internal flash memory	32 MByte Flash (internal)
Internal main memory	128 MByte RAM (internal)
interfaces	2 x RJ 45 (internal Switch), 10/100 MBit
Diagnostics LEDs	1 x Power, 2 x LAN, 1 x K-Bus, 1 x Flash-Zugriff
Clock	internal battery-backed clock for time and date
Operating system	Microsoft Windows CE
Control software	TwinCAT-CE-PLC-Runtime or TwinCAT-CE-NC-PTP-Runtime
Power supply	24 V _{DC} (-15%/+20%) To meet the UL requirements use a 4 A fuse or a power supply that has to satisfy <i>NEC class 2!</i>
Dielectric strength	500 V _{rms} (supply/internal electronics)
I/O connection	K-bus (Bus Terminals)
NOVRAM	128 kByte
I/O-DPRAM	4 kByte
Power supply I/O terminals	2 A
Max. power loss	6.5 W (including CX9010-xxxx system interfaces)
Dimensions (W x H x D)	59 mm x 100 mm x 91 mm
weight	ca. 250 g
Operating / storage temperature	0° C ... +50° C / -25° C ... +85° C
Relative humidity	95% no condensation
Vibration/shock resistance	conforms to EN 60068-2-6 / EN 60068-2-27/29
EMC resistance burst/ ESD	conforms to EN 61000-6-2/EN 61000-6-4
Protection class	IP 20



2.3.5 Configurations

The order identifier of the basic CPU module is derived as follows:

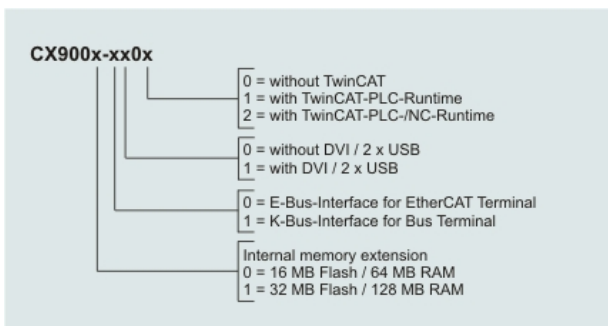

Following CX9000 configurations are available:

Ordering information	16 MB Flash 64 MB RAM	32 MB Flash 128 MB RAM	E-Bus	K-Bus	DVI, 2 x USB	no TwinCAT	TwinCAT-PLC-Run-time	TwinCAT-NC-Run-time
CX9000-0000	X	-	X	-	-	X	-	-
CX9000-0001	X	-	X	-	-	-	X	-
CX9000-1000	X	-	-	X	-	X	-	-
CX9000-1001	X	-	-	X	-	-	X	-
CX9001-0000	-	X	X	-	-	X	-	-
CX9001-0001	-	X	X	-	-	-	X	-
CX9001-0002	-	X	X	-	-	-	X	X
CX9001-0100	-	X	X	-	X	X	-	-
CX9001-0101	-	X	X	-	X	-	X	-
CX9001-0102	-	X	X	-	X	-	X	X
CX9001-1000	-	X	-	X	-	X	-	-
CX9001-1001	-	X	-	X	-	-	X	-
CX9001-1002	-	X	-	X	-	-	X	X
CX9001-1100	-	X	-	X	X	X	-	-
CX9001-1101	-	X	-	X	X	-	X	-
CX9001-1102	-	X	-	X	X	-	X	X

2.3.6 Configurations

The order identifier of the basic CPU module is derived as follows:

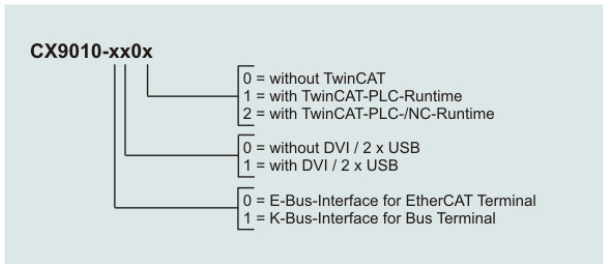

Following CX9000 configurations are available:

Ordering information	E-Bus	K-Bus	DVI, 2 x USB	no TwinCAT	TwinCAT-PLC-Run-time	TwinCAT-NC-Runtime
CX9010-0000	x	-	-	x	-	-
CX9010-0001	x	-	-	-	x	-
CX9010-0002	x	-	-	-	x	x
CX9010-0100	x	-	x	x	-	-
CX9010-0101	x	-	x	-	x	-
CX9010-0102	x	-	x	-	x	x
CX9010-1000	-	x	-	x	-	-
CX9010-1001	-	x	-	-	x	-
CX9010-1002	-	x	-	-	x	x
CX9010-1100	-	x	x	x	-	-
CX9010-1101	-	x	x	-	x	-
CX9010-1102	-	x	x	-	x	x

2.3.7 Connections

The system is supplied with power via the integrated power supply. This is wired as follows:

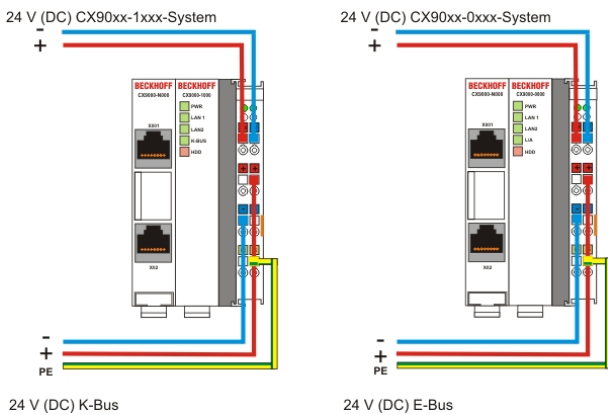

The basic module is powered via the upper connectors with 24 V DC. The terminal bus can be supplied via the lower connections.

UL requirements

 DANGER	<p>Compliance of the UL requirements</p> <p>To meet the UL requirements, the CX-Controllers must not be connected to unlimited power sources!</p>
--	--



CPU basic module with 2 Ethernet RJ 45 connectors:

RJ 45 interface (socket):



Table 1: Assignment of the RJ45-interface, Port 1:

PIN	Signal	Description
1	TD +	Transmit +
2	TD -	Transmit -
3	RD +	Receive +
4	connected	not used
5		
6	RD -	Receive -
7	connected	not used
8		



TD & RD are exchanged at the hubs or between two PCs.

Table 2: Assignment of the RJ45 interface, Port 2:

PIN	Signal	Description
1	TD +	Transmit +
2	TD -	Transmit -
3	RD +	Receive +
4	connected	not used
5		
6	RD -	Receive -
7	connected	not used
8		

TD & RD are exchanged at the hubs or between two PCs.

Connection of the Ethernet ports:

 Attention	<p>Ethernet ports</p> <p>The two Ethernet ports of a basic CPU module must not be connected to the same external switch!</p>
 Note	<p>Only for LAN</p> <p>Only for use in LAN, not for connection to telecommunication circuits.</p>

Schematic structure of the network components:

The CX90x0 features two MAC blocks. The first one (MAC1) operates the network interfaces for the Ethernet ports. The two outputs are connected via a switch. In this way a line structure can be configured as described below. From an operating system perspective this represents a **single** connection. The second block (MAC2) operates the extended PC104 bus. The second physical network connection is used to run the E-bus connection. (in version CX900x-0xxx) The signals are connected to an FPGA. This unit converts the Ethernet signals to E-bus signals. So EtherCAT terminals can be connected to the system.

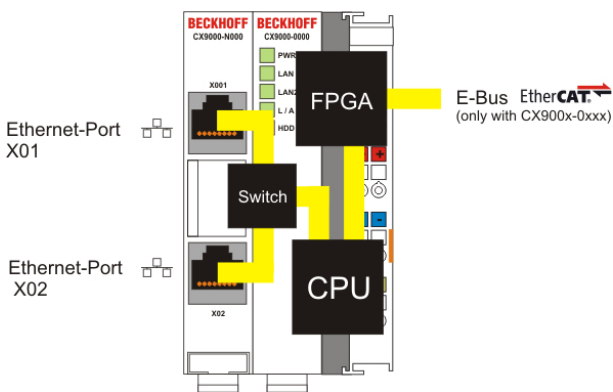

If K-bus is used as terminal bus (CX900x-1xxx), the second MAC-interface is **not** connected.

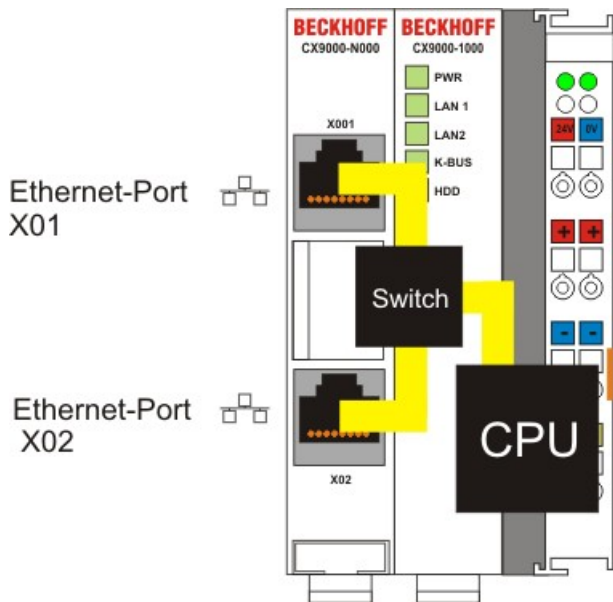

Operating system perspective:

The operating system only sees one of the connections for the network interface. The status is always connected, since the switch is connected directly.

These interfaces are connected to an internal 3-port switch and offer a simple option for creating a line topology without the need for additional Ethernet switches.

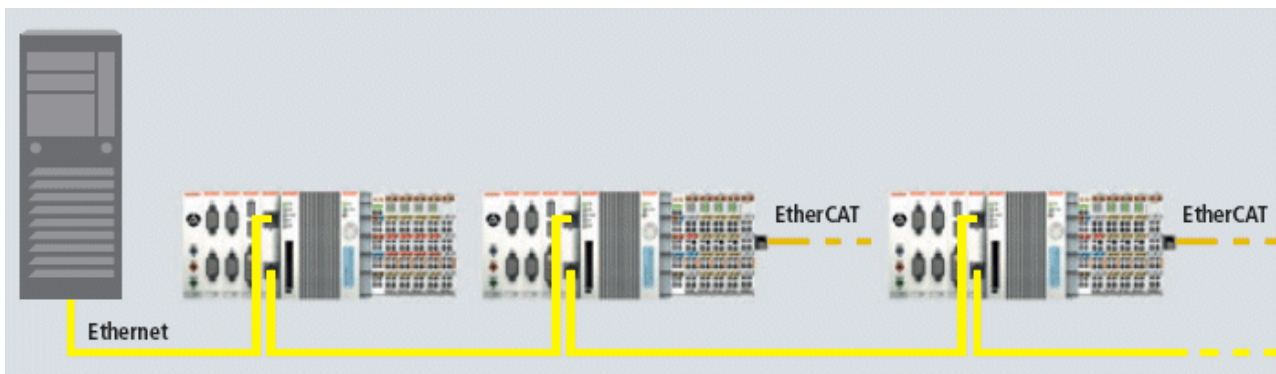

Basic CPU module with DVI/USB interface:

In addition to the two Ethernet ports, this basic module also features DVI/USB interfaces. The pin assignment of the basic CPU module with two USB and a DVI-I interface is explained under the associated [CX90x0-N010 \[▶ 24\]](#) system interface.

Applicable to all basic CPU modules:

LED

The green power LED (PWR) is on if the basic CPU module is connected correctly to a live power supply unit.

Compact Flash slot

Further information can be found under Compact Flash slot

2.3.8 Battery compartment

The battery compartment is located on the left-hand side of the CPU module, between the two Ethernet ports.

It can be opened with the aid of a screwdriver (proceed carefully in order to avoid damage).

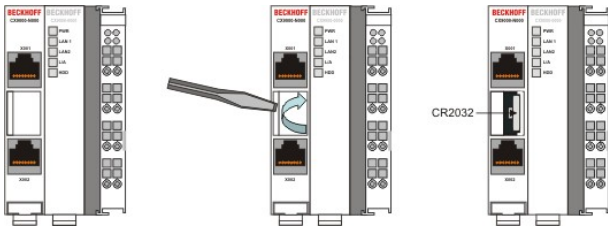

The battery is a CR2032 type from Panasonic

with the following specification:

Battery type	Electrical properties (at 20° C)		Standard charge	Dimensions		
	nominal voltage	nominal capacity	continuous load	Diameter	Height	Weight
	3.0 V	225 mAh	0.20 mA	20.0 mm	3.20 mm	3.1 g



DANGER

Exploding battery

Replace battery part. No. CR2032 manufactured by Sanyo or Panasonic only. Use of another battery may present a risk of fire or explosion. WARNING, battery may explode if mis-treated. Do NOT recharge, disassemble or dispose of in fire.



Note

Battery maintenance

The battery must be changed every 5 years. Spare batteries can be ordered from Beckhoff Service. Battery-recycling: Used batteries must be disposed of in accordance with national electronics scrap regulations. Used batteries may contain harmful substances or heavy metal that can harm the environment and health. Batteries will be recycled. They contain important commodities as iron, zinc, nickel or manganese. The environment and Beckhoff thank for your understanding.

2.3.9 CX90x0 : Dip switch settings

General

 Attention	<p>Reset the System</p> <p>In general there is no need to change the dip switch settings. The switches are installed in case of major faults, to reset the system, provide debug messages, bypass TwinCAT start and update the image. Never change a running system !</p>
---	--

To get access to the dip switches, you have to open the over of the battery compartment. It is located between the two ethernet connectors on the front of the CX90x0-N000 module. To open the cover proceed as follows:

1. Power down the CX90x0
2. Open the battery compartment (located between two ethernet ports)
It can be opened with the aid of a screwdriver (proceed carefully in order to avoid damage).

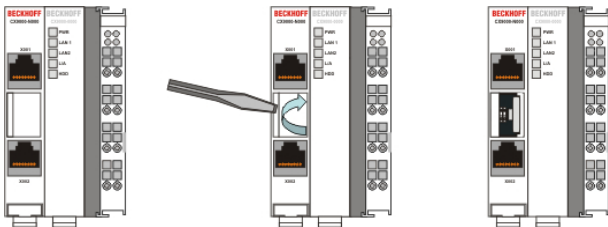

Once the compartment is opened, the four dip switches can be accessed. They are located left of the battery holder. On normal operation mode all switches are set to OFF. (All switches are down).



To change the settings of a dip switch its is advised to use a screwdriver with a small blade (2.5 mm x 7.5 cm length and parallel shaft, Beckhoff order number: ZB8700). Use the edge to move the switches with caution!

The switches have four functions:

- Reset CX90x0-System to defaults.
- Send debug codes to COM1 (if connected).
- Update mode to obtain a new image via PC server (Boot menu via COM1).
- Force TwinCAT to start in config mode.

The functions are described in detail below:

Reset to Factory Settings:

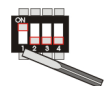

1. Set dip switch 1 to ON (move switch 1 up).
2. Connect CX-System to power and boot system. After a complete boot, the registry is regenerated.
3. Set dip switch 1 back to OFF (switch 1 down) and close cover.

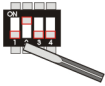
Report debug messages to COM1:

1. Set dip switch 2 to ON (move switch 2 up).
2. Connect a serial monitor device (printer or terminal) to COM1 port. The settings for the interface are: 38400 baud, 8 bits , NO parity and 1 stop bit (38400,8,N,1).
3. Connect CX-System to power and boot system. Debug messages are sent to the monitor device.
4. After finishing diagnosis power set dip switch 2 back to OFF (switch 2 down) and close cover.

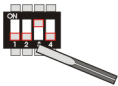
Bootstrap Mode for updates:

The Bootstrap Mode is implemented for image updates. The procedure is more complex so it is described in an [own part of the documentation \[► 44\]](#). Refer to the instruction for the process.

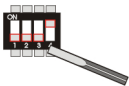
Force TwinCAT in "Config Mode":

For some cases (e.g. errors in boot project) it is necessary to start TwinCAT in Config mode. So the boot project can be corrected or other settings can be (re)setted.

1. Set dip switch 4 to ON (move switch 4 up).
2. Connect CX-System to power and boot system.
3. Make changes to the PLC
4. power down the system. Set dip switch 4 back to OFF (switch 4 down) and close cover.

2.4 System interfaces

2.4.1 Technical Data

Dimensions:

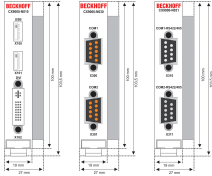

Like for the other members of the CX family, a number of optional interface modules are available for the basic CX90x0 CPU module that can be installed ex works. The following interfaces are available:

- CX90x0-N010 DVI / USB Module
- CX90x0-N030 serial interface for RS232
- CX90x0-N031 serial interface for RS422 / RS485

The CX90x0-N010 option can be connected to Beckhoff Control Panels or standard monitors with DVI or VGA input via the DVI or USB interfaces. Devices such as printer, scanner, mouse, keyboard, mass storage, CR-RW etc. can be connected via the USB 2.0 interfaces. The modules CX90x0-N030 offers two serial RS232 interfaces with a maximum transfer speed of 115 kbaud. These interfaces can be implemented in pairs as RS422/RS485, in which case they are identified as CX90x0-N031 respectively. The system interfaces cannot be retrofitted or expanded in the field. They are supplied ex factory in the specified configuration and cannot be separated from the CPU module. The system interfaces run through the internal PC104 bus, so that further CX components can be connected. The power supply of the system interface modules is ensured via the internal PC104 bus.

Technical Data	CX90x0-N010	CX90x0-N030	CX90x0-N031
Interfaces	1 x DVI + 2 x USB 2.0 max. 100 mA per port	1 x COM1+2, RS232 1 x COM3+4, RS232	1 x COM1+2, RS422/ RS485 1 x COM3+4,RS422/ RS485
Connection type	DVI-I 29-pin socket + 2 USB Ports type A	2 x D-Sub plug 9-pin	2 x D-Sub plug 9-pin
Properties	DVI-I interface also carries out VGA signals (DVI-A)	max. baud rate 115 kbaud, can not be used simultaneously with N031/ N041	max. baud rate 115 kbaud, can not be used simultaneously with N030/ N040
Power supply	via system bus (Through internal power supply in CX90x0 module)		
Dimensions	19 mm x 100 mm x 51 mm		
Operating temperature	0 °C ... +55 °C		
Storage temperature	-25 °C ... +85 °C		
Relative humidity	95% no condensations		
Vibration/Shock resistance	conforms to EN 60068-2-6 / EN 60068-2-27/29		
EMC resistance burst / ESD	conforms to EN 61000-6-2/EN 61000-6-4		
Protection class	IP 20		
wight	app. 80 g		

2.4.2 CX90x0-N010 connections

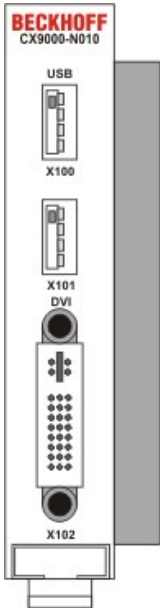

In addition to the two Ethernet interfaces, this module features a DVI-I and two USB interfaces.



Note

System interface

The system interface CX90x0-N010 can only be used in CX90x0 system with large memory (CX9001-x00x).

DVI-I interface

The DVI-I interface transfers analog and digital data and is suitable for connection to analog graphics cards with 15 pin D-Sub connector and digital graphics cards with DVI-D output. The resolution at the screen or the Beckhoff Control Panel depends on the distance (maximum 5 m).

The DVI interface uses VGA signals, so that the connection of CRT VGA monitors to the CX1000 system using a DVI to VGA adapter is also possible. This adapter is available as an accessory.

DVI-I socket:

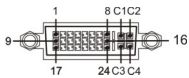

Pin	Assignment	Pin	Assignment	Pin	Assignment
1	TMDS Data 2-	9	TMDS Data 1-	17	TMDS Data 0-
2	TMDS Data 2+	10	TMDS Data 1+	18	TMDS Data 0+
3	TMDS Data 2/4 Shield	11	TMDS Data 1/3 Shield	19	TMDS Data 0/5 Shield
4	not connected	12	not connected	20	not connected
5	not connected	13	not connected	21	not connected
6	DDC Clock	14	+ 5V Power	22	TMDS Clock Shield
7	DDC Data	15	Ground (+5V, Analog H/V Sync)	23	TMDS Clock +
8	Analog Vertical Sync	16	Hot Plug Detect	24	TMDS Clock -

Pin assignment (cross)

Pin	Assignment
C1	Analog Red Video Out
C2	Analog Green Video Out
C3	Analog Blue Video Out
C4	Analog Horizontal Sync

Resolution at the monitor:

Resolution in pixels	Distance of the interface from the monitor
1600 x 1200	5 m
1280 x 1024	5 m
1024 x 768	5 m
800 x 600	5 m
640 x 480	5 m

USB interface:

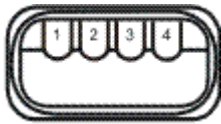

The USB socket is a type A socket. The USB interface complies to USB 2.0 specification

Pin	Assignment	Typical assignment
1	VBUS	Red
2	D-	White
3	D+	Green
4	GND	Black
Shell	Shield	Drain Wire

2.4.3 CX90x0-N030 connections

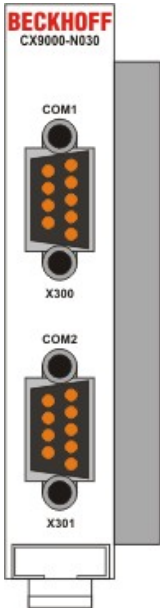

The CX90x0-N030 system interface features two RS232 interfaces, COM1 and COM2 (9 pin Sub-D plug connector).

The maximum baud rate on all channels is 115 kBit. The pin assignment for all interfaces is equal and described below. The interface parameter can be set in the operating system or in the PLC program.

RS232 COM interface (connector):

Table 3: Pin assignment COM interface:

PIN	Signal	Type	Description
1	DCD	Signal in	Data Carrier Detected
2	RxD	Signal in	Receive Data
3	TxD	Signal out	Transmit Data
4	DTR	Signal out	Data Terminal Ready
5	GND	Ground	Ground
6	DSR	Signal in	Dataset Ready
7	RTS	Signal out	Request to Send
8	CTS	Signal in	Clear to Send
9	RI	Signal in	Ring Indicator



Note

System interface

The system interface CX90x0-N030 can only be used instead and not simultaneously with system interface CX90x0-N031.

2.4.4 CX90x0-N031 connections

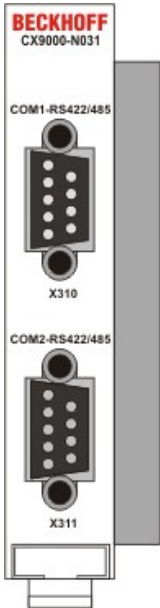

The CX90x0-N031 system interface features two RS422 / RS 485 interfaces, COM1 and COM2 (9 pin Sub-D plug connector).

The maximum baud rate on all channels is 115 kBit. The pin assignment for all interfaces is equal and described below. The interface parameter can be set in the operating system or in the PLC program.

RS232 COM interface (connector):

Table 4: Pin assignment COM interface:

PIN	Signal	Type	Description
2	TxD+	Data-Out +	Transmit 422
3	RxD+	Data-In +	Receive 422
5	GND	Ground	Ground
6	VCC	VCC	+5V
7	TxD-	Data-Out -	Transmit 422
8	RxD-	Data-In -	Receive 422

For RS 485 Pin 2 and 3 (Data +) as well as Pin7 and 8 (Data -) have to be connected..

Setting the interface parameter

If the system interface CX90x0-N031 resides at the end of the CX90x0-system block, it is easy to access the dip switches. The dip switches for the configuration of the RS485/422 interfaces can be found at the left side of the module. If you remove the grey cover you can see the switch:

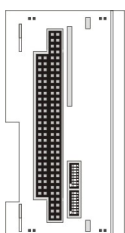

The upper switch sets the parameters for the upper interface, the lower switch sets the parameter for the lower interface. The system must be powered down, if the settings of the switches are changed! The settings for default use should be mentioned by ordering the interface module.

Settings DIP switches RS485:*Table 5: RS485 without Echo, End-Point (Terminated) DEFAULT setting*

DIP	Status	Function
1	off	Echo on
2	on	Echo off
3	on	Auto send on
4	off	Always send on
5	on	Auto receive on
6	off	Always receive on
7	on	Term on
8	on	Term on

Table 6: RS485 with Echo, End-Point (Terminated)

DIP	Status	Function
1	on	Echo on
2	off	Echo off
3	on	Auto send on
4	off	Always send on
5	off	Auto receive on
6	on	Always receive on
7	on	Term on
8	on	Term on

Table 7: RS485 without Echo, Drop-Point (without Termination)

DIP	Status	Function
1	off	Echo on
2	on	Echo off
3	on	Auto send on
4	off	Always send on
5	off	Auto receive on
6	on	Always receive on
7	off	Term on
8	off	Term on

Table 8: RS485 with Echo, Drop-Point (without Termination)

DIP	Status	Function
1	on	Echo on
2	off	Echo off
3	on	Auto send on
4	off	Always send on
5	off	Auto receive on
6	on	Always receive on
7	off	Term on
8	off	Term on

Setting DIP-Switches RS422:

Table 9: RS422 full duplex end point

DIP	Status	Function
1	on	Echo on
2	off	Echo off
3	off	Auto send on
4	on	Always send on
5	off	Auto receive on
6	on	Always receive on
7	on	Term on
8	on	Term on



Note

System interface

The system interface CX90x0-N031 can only be used instead and not at the same time with system interface CX90x0-N030.

Also see about this

Removal and disposal [[▶ 42](#)]

3 Transport

3.1 Unpacking, installation and transport

The specified storage conditions must be adhered to (see "Technical data").

Dimensions and weight of the individual modules:

Dimensions (W x H x D): 19 x 100 x 91 mm (system interface) , 58 x 100 x 91 mm (basic module)

Weight: 80 g (system interface) to 250 g (basic module)

Unpacking

Proceed as follows to unpack the unit:

1. Remove packaging.
2. Do not discard the original packaging. Keep it for future relocation.
3. Check the delivery for completeness by comparing it with your order.
4. Please keep the associated paperwork. It contains important information for handling the unit.
5. Check the contents for visible shipping damage.
6. If you notice any shipping damage or inconsistencies between the contents and your order, you should notify Beckhoff Service.



Attention

Danger of damage to the unit

During transport in cold conditions, or if the unit is subjected to extreme temperature swings, condensation on and inside the unit must be avoided.

Prior to operation, the unit must be allowed to slowly adjust to room temperature. Should condensation occur, a delay time of approximately 12 hours must be allowed before the unit is switched on.

Installation

The devices are designed for installation in control cabinets. You will find installation instructions in the chapter mechanical mounting.

Shipping and relocation

Despite the robust design of the unit, the components are sensitive to strong vibrations and impacts. During transport, your computer should therefore be protected from excessive mechanical stress. Therefore, please use the original packaging.

4 Assembly and connecting

4.1 Mechanical assembly

4.1.1 Dimensions

The CX90x0 product range is characterized by small overall installed size and high modularity. For project planning purposes, a CPU module, a power supply unit and the associated system interfaces and fieldbus interfaces have to be provided. The overall width of the application is made up of the individual modules. With a height of 100 mm, the module dimensions exactly match those of the Beckhoff Bus Terminals. Together with the lowered connector surfaces, this means that it can be used in a standard terminal box with a depth of 120 mm.

 Attention	<p>Cooling the device</p> <p>To ensure cooling to the device in operation it is important keep the safety distances.</p>
---	---

CX90x0-x000 CPU Basic module:

without heat sink:

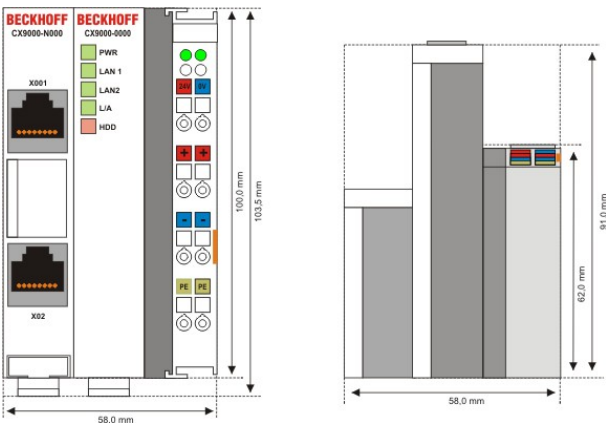

with heat sink:

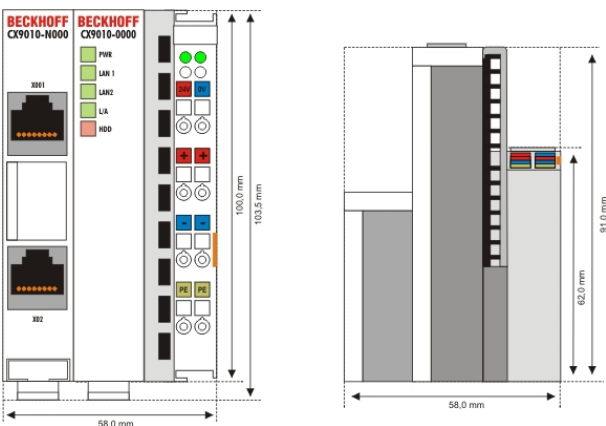

CX90x0-N0x0 System interfaces:

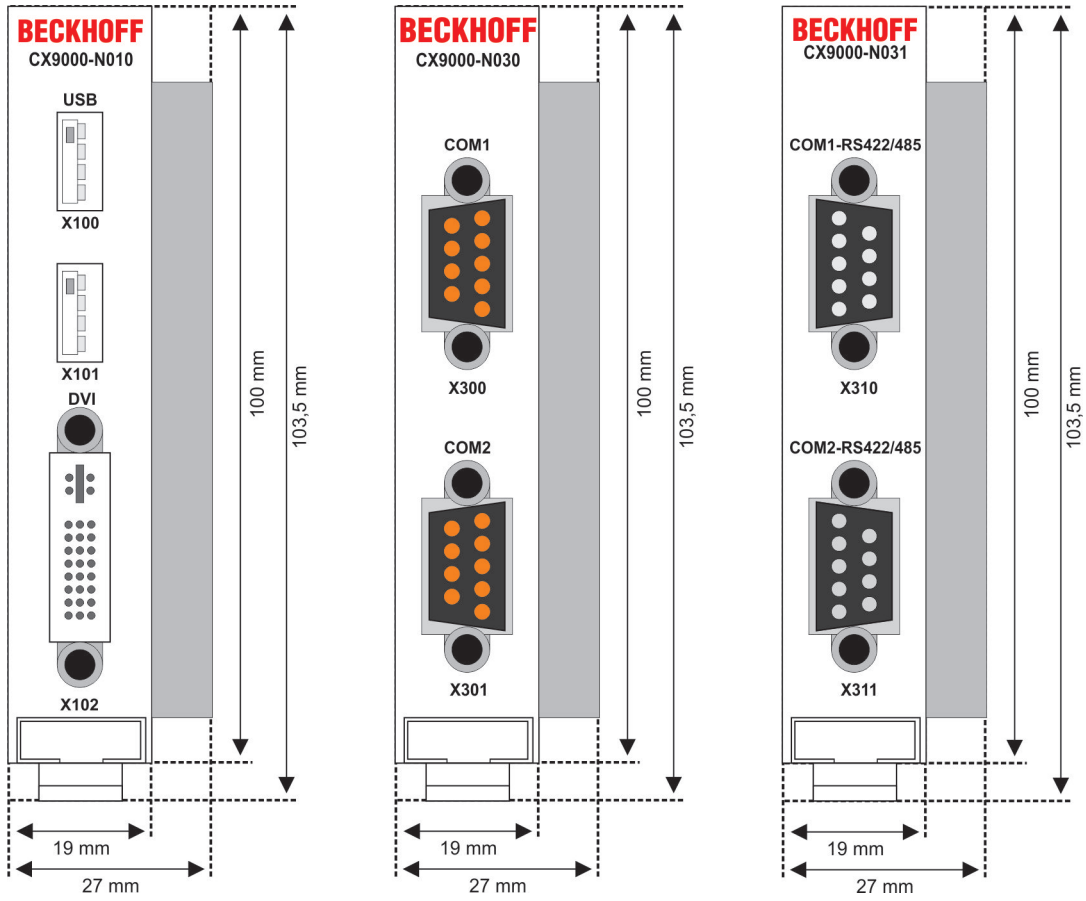

4.1.2 Mechanical assembly of the basic module

The installation of the modules takes place in three steps:

1. The sequence of the modules

The basic CPU module with system interfaces, which are factory-installed on the left side, is extended with the power supply unit on the right and with the fieldbus connection (master or slave) left side if available.

2. Engaging on the top-hat rail

On the bottom of the modules, there is a white tension strap, which is connected with a latching mechanism. These tension straps must be pulled down before attaching to the top-hat rail. This can be done using an ordinary screwdriver and a slight turn.

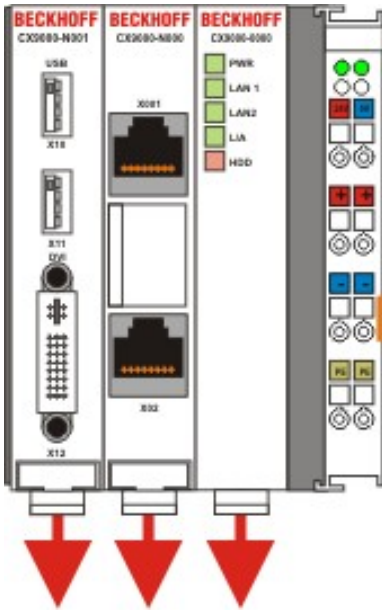

Then fix the CX9000 block on the top hat-rail using the latching straps. You should hear a soft click.

Only apply pressure at insensitive points of the housing (edges). Never apply pressure on the display, the buttons or movable parts of the CX-system.

After successful latching on the top-hat rail the straps should be pushed back to their original position.

Note:

A locking mechanism prevents the individual housings from being pulled off again. Detailed information relating to disassembly of the CX-System configuration from the top-hat rail can be found on page "[Removal and disposal \[▶ 42\]](#)".

Installation position:

 Attention	<p>Mounting the device</p> <p>The maximum ambient temperature for CPU modules mounted on a top-hat rail is 55°C. The orientation in which the device is fitted must be selected in such a way that cooling air can flow vertically through the ventilation holes. The images show the correct installation position. Observe minimum clearance! Mounting must provide a clearance of 30 mm both above and below a CX90xx device combination to ensure adequate ventilation of the base CPU module and the power supply unit.</p>
---	---

Correct installation position:

The high-performance CX9000 system generates a significant amount of heat, which is dissipated via a passive ventilation system. This system requires the unit to be mounted correctly. Ventilation openings are located at the top and bottom of the housing. The system can be installed in the following positions:

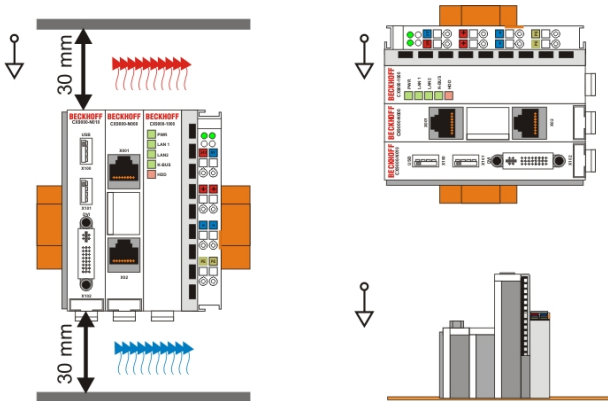

The following positions are invalid:

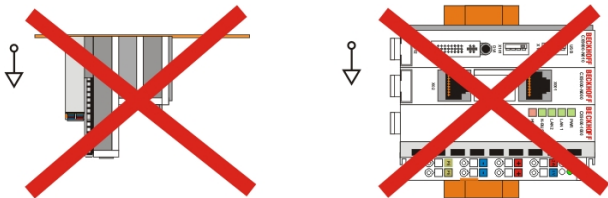

4.1.3 Mechanical installation of the UPS Module



Note

The power fail signal

The UPS module for CX90x0 is not fully supported by TwinCAT yet. The UPS module should be connected the described way. To get the power fail signal (pin 3 on UPS) must be connected to a digital input terminal. In this way the PLC can access the power fail signal and save the data or shut down the system. The shutdown time can only be set by the selector on the front side of the UPS (best choice is 0). In case of shutdown the UPS will restart the system after power fail.

0. Switching off and disconnecting the power supply

Before a CX90x0 system can be dismantled, the system should be switched off, and the power supply should be disconnected.

1. Removing from the top-hat rail:

Before the individual CX90x0 modules are disconnected, the whole CX90x0 hardware block should be removed from the top-hat rail. Proceed as follows:

1.1. Release and remove the first Terminal next to the power supply unit on the top-hat rail.

First remove any wiring from power supply unit *and* then from the first terminal on the top-hat rail next to the power supply unit. If the wiring is to be reused for another system, it is advisable to make a note of the connections. Then pull the orange terminal release (see arrow) to release the terminal and pull it out.

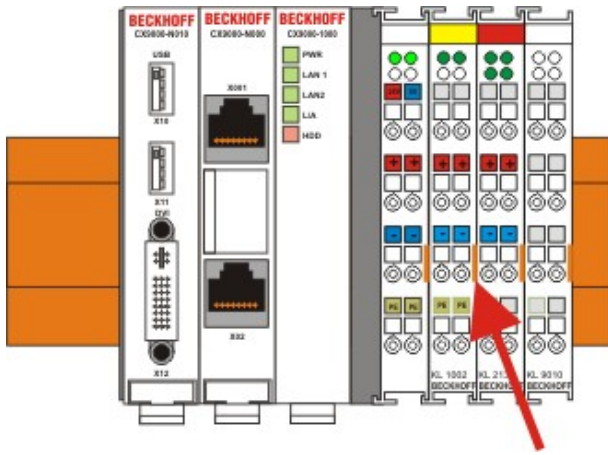

1.2. Releasing the CX90x0 system

In order to release the CX-block, pull the white straps at the bottom of the module in the direction of the arrows. They will lock in the extended position. After pulling the terminal release of the power supply unit, the block can be removed *carefully* from the top-hat rail.

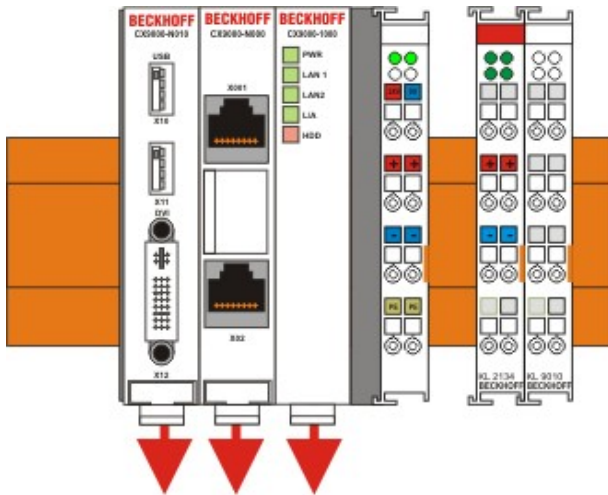

2 Assembly of the CPU basic module with UPS module

2.1 Assembly the the CX90x0 system block

In order to be able to connect the UPS to the basic CX90x0 module, the cover of the basic module has to be removed first. This is achieved by applying slight pressure on the cover. The individual modules are simply plugged together. The PC104 connector plugs should be handled carefully in order to avoid damage. When correctly assembled, no significant gap can be seen between the attached housings. If the modules are assembled the cover can be replaced.

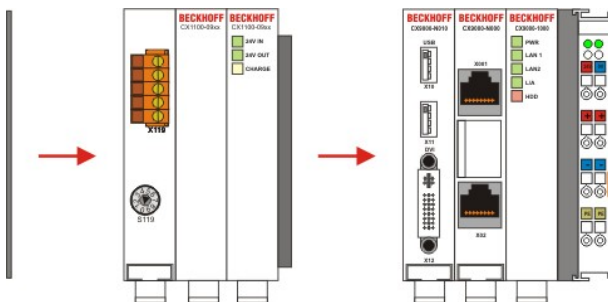

2.2 Engaging on the top-hat rail

Before engaging the system back on the top-hat rail the user should ensure all white tension straps are pulled down. The user should take care of the space between the terminals and the Embedded PC system. The space for the removed terminal must be kept to reinstall the terminal.

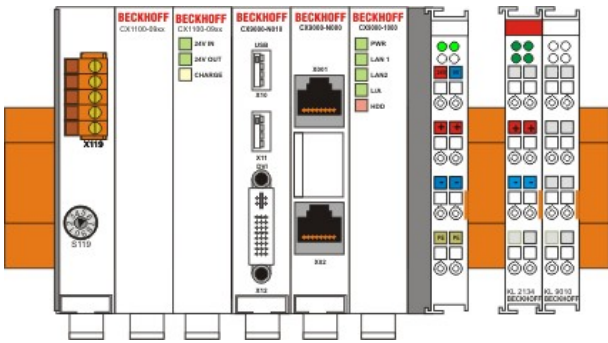

Then fix the CX9000 block on the top hat-rail using the latching straps. You should hear a soft click.

Only apply pressure at insensitive points of the housing (edges). Never apply pressure on the display, the buttons or movable parts of the CX10x0 system.

After successful latching on the top-hat rail the straps should be pushed back to their original position.

2.3 Connecting the Embedded PC to the terminal bus

By reinstalling the once removed terminal the system is connected to the bus.

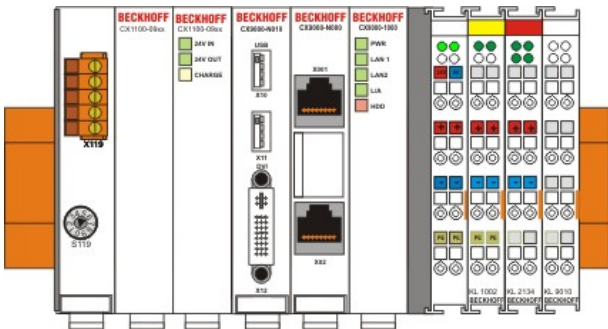

Finally the wiring must be reinstalled. The removed terminal is reconnected as before. The power supply is now connected via the UPS-connectors. (see chapter connections for details)

4.2 Start-up procedure

4.2.1 Switching the PC on and off

Switching on

The power supply for the basic CPU module comes from the power supply unit. The basic CPU module starts automatically when the power supply unit is connected to the mains.

Switching on for the first time

When you switch on the PC for the first time, the pre-installed operating system (optional) will be started.

Switching off

The Embedded PC switches off when the power supply unit is switched off. The control software typically running on Embedded PCs should be shut down or stopped correctly. A user who may not close software may also not switch the Embedded PC off, since data can be lost from the hard disk by switching off while software is running.

Once the software has been stopped, the operating system can be shut down. Only then should the power supply be interrupted.

5 Error handling and diagnostics

5.1 CPU basic module

5.1.1 LEDs Basic CPU-module (E-Bus)

The behavior of the CX9000 and the CX9010 is identical. As reference the LED behavior of the CX9000 is shown below.

Display	LED	Meaning	
	PWR	red	TwinCAT is in STOP mode
		green	TwinCAT is in RUN mode
		blue	TwinCAT is in CONFIG mode
		off	System is offline
	LAN 1	LAN Link, (green) LINK/ACTIVITY for first switched LAN PORT (CX9000_N000)	
	LAN 2	LAN Link, (green) LINK/ACTIVITY for second switched LAN PORT (CX9000_N000)	
	L / A	(Link Activity) flashes in traffic on E-bus.	
HDD	Read/Write Compact Flash (red) Indicates access to the CF card.		

5.1.2 LEDs Basic CPU-module (K-Bus)

The behavior of the CX9000 and the CX9010 is identical. As reference the LED behavior of the CX9000 is shown below.

Display	LED	Meaning	
	PWR	red	TwinCAT is in STOP mode
		green	TwinCAT is in RUN mode
		blue	TwinCAT is in CONFIG mode
		off	System is offline
	LAN 1	LAN Link, (green) LINK/ACTIVITY for first switched LAN PORT (CX9000_N000)	
	LAN 2	LAN Link, (green) LINK/ACTIVITY for second switched LAN PORT (CX9000_N000)	
	L / A	(Link Activity) flashes in traffic on E-bus.	
K-Bus	Flashes in traffic on K-bus / reports errors K-Bus not active (off) K-Bus running (flashes green) K-Bus error (red) see tables below		
HDD	Read/Write Compact Flash (red) Indicates access to the CF card		

Table 10: The I/O error K-Bus LED blink code

Fast blinking	Start of the error code
First slow sequence	Error code
Second slow sequence	Error code argument

LEDs for K-Bus diagnosis

Error code	Error code argument	Description	Remedy
Persistent, continuous blinking		EMC problems	- Check power supply for overvoltage or undervoltage peaks - Implement EMC measures - If a K-Bus error is present, it can be localised by a restart of the power supply (by switching it off and then on again)
1 pulse	0	EEPROM checksum error	Revert to the manufacturer's setting
	1	Code buffer overflow	Insert fewer Bus Terminals. The programmed configuration has too many entries in the table
	2	Unknown data type	Software update required for the power supply
2 pulses	0	Programmed configuration has an incorrect table entry	Check programmed configuration for correctness
	n (n > 0)	Table comparison (Bus Terminal n)	Incorrect table entry
3 pulses	0	K-Bus command error	- No Bus Terminal inserted - One of the Bus Terminals is defective; halve the number of Bus Terminals attached and check whether the error is still present with the remaining Bus Terminals. Repeat until the defective Bus Terminal is located.
4 pulses	0	K-Bus data error, break behind the power supply	Check whether the n+1 Bus Terminal is correctly connected; replace if necessary.
	n	Break behind Bus Terminal n	Check whether the Bus End Terminal 9010 is connected.
5 pulses	n	K-Bus error in register communication with Bus Terminal n	Exchange the nth bus terminal
9 pulses	0	Checksum error in Flash program	Revert to the manufacturer's setting
	n (n>0)	Bus Terminal n is not consistent with the configuration that existed when the boot project was created	Revert to the manufacturer's setting which will clear the boot project.
14 pulses	n	nth Bus Terminal has the wrong format	Start the power supply again, and if the error occurs again then exchange the Bus Terminal.
15 pulses	n	Number of Bus Terminals is no longer correct	Start the power supply up again.
16 pulses	n	Length of the K-Bus data is no longer correct	Start the power supply up again.

Error code argument

The number of pulses indicates the position of the last Bus Terminal before the fault. Passive Bus Terminals, such as a power feed terminal, are not included in the count.

In the case of some errors, rectification does not cause the power supply to leave the blink sequence. The power supply can only be restarted by switching its supply voltage off and on again.

5.1.3 Terminal Bus Analysis in PLC-Program

To analyze the terminal bus (K-Bus) the programmer can access the registers described in the architecture. The access to the PLC-program is realized via TwinCAT. The registers are described in the architecture of the terminal bus connectors (CX1100-000x).

For analysis four signals / variables are used:

- BusState (describes the state of the bus: 0 -> no error, 1 -> bus error)
- ErrorCode (same error code as the LED blink code)
- ErrorArg (same argument code LED blink code)
- Request[0] (output to request error codes / reset bus)

In the PLC program some external variables must be defined :

```
VAR
    k_bus_request AT %QX0.0      : BOOL;

    k_bus_err_code AT %IB0 : USINT;
    k_bus_err_arg AT %IB1 : USINT;
    k_bus_state AT %IB2 : USINT;

END_VAR
```

In the PLC program the analysis can be done as follows: (this is only pseudo code)

```
....

IF k_bus_state = 1 THEN      (* an error occurred on K-Bus*)
    k_bus_request := TRUE;    (* request vaules for ErrCode and ErrArg *)

CASE k_bus_err_code OF
0 : return;                 (* should not happen, though an error occurred *)
1 : CASE k_bus_arg OF
    0 : report error; (* EEPROM checksum error *)
    1 : report error; (* overflow in code buffer *)
    2 : report error; (* unknown datatype *)
    END_CASE;
2 : CASE k_bus_arg OF
    0 : report error; (* programmed configuration, wrong table entry *)
    ELSE report error; (* wrong table entry *)
    END_CASE;
3 : report error      (* K-Bus command error *)
4 : CASE k_bus_arg OF
    0 : report error; (* break after power supply *)
    ELSE report error; (* break after terminal 'k_bus_arg' *)
    END_CASE;
5 : report error      (* K-Bus-error during register-communication with terminal 'k_bus_arg' *)
9 : CASE k_bus_arg OF
    0 : report error; (* checksum error in program flash *)
    ELSE report error; (* terminal 'k_bus_arg' does not exist in boot configuration *)
    END_CASE;
14 : report error     (* 'k_bus_arg'-th terminal has wrong format *)
15 : report error     (* wrong number of bus terminals *)
16 : report error     (* length of K-Bus data is invalid *)
END_CASE

k_bus_request := TRUE;    (* reset bus, if reason for error is removed, bus starts again *)

....
```

To make the control work, the register and the program must be linked in System Manager. If the PLC program is attached in System Manager the following signals are available:

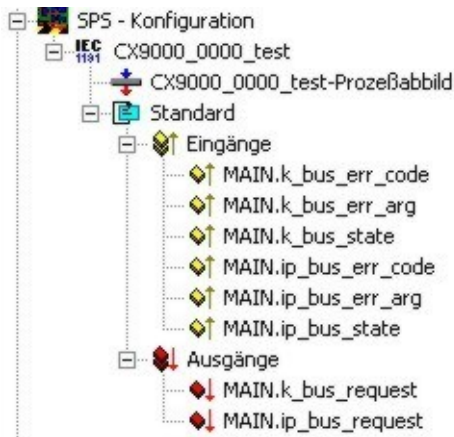

Analog the registers of the terminal bus are shown in System Manager :

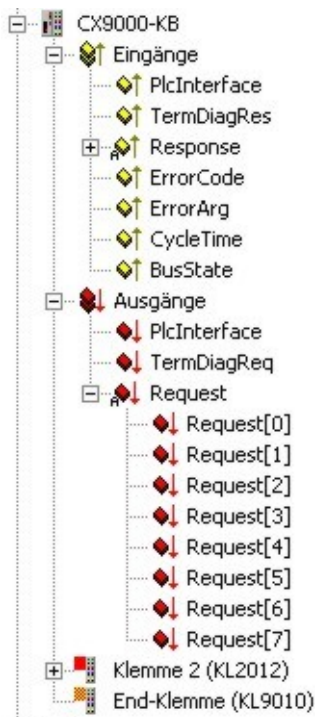

Link signals and variables :

k_bus_err_code with ErrorCode

k_bus_err_arg with ErrorArg

k_bus_state with BusState

and

k_bus_request with Request[0]

If all signals are linked the programmer can load configuration and PLC program onto the system.

6 Decommissioning

6.1 Removal and disposal

A CX90x0 hardware configuration is dismantled in 2 stages:

0. Switching off and disconnecting the power supply

Before a CX-System can be dismantled, the system should be switched off, and the power supply should be disconnected.

1. Removing from the top-hat rail:

Before the individual CX-System modules are disconnected, the whole CX-hardware block should be removed from the top-hat rail. Proceed as follows:

1.1. Release and remove the first Terminal next to the power supply unit on the top-hat rail.

First remove any wiring from power supply unit *and* then from the first terminal on the top-hat rail next to the power supply unit. If the wiring is to be reused for another system, it is advisable to make a note of the connections. Then pull the orange terminal release (see arrow) to release the terminal and pull it out.

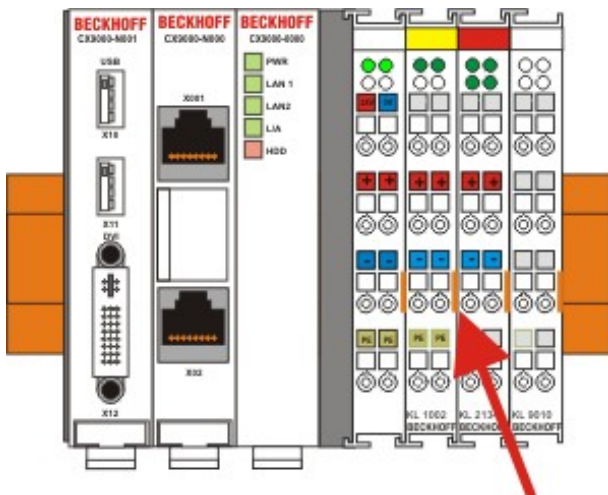

1.2. Releasing the CX-System

In order to release the CX-block, pull the white straps at the bottom of the module in the direction of the arrows. They will lock in the extended position. After pulling the terminal release of the power supply unit, the block can be removed *carefully* from the top-hat rail.

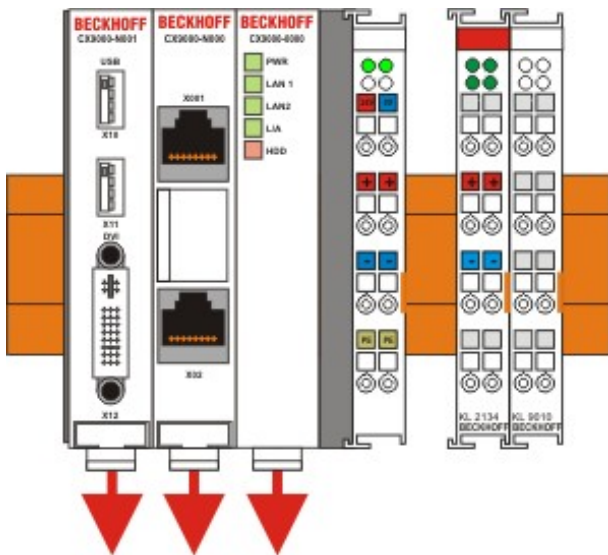

2. Separating the individual modules

2.1. Separating the power supply unit, the CX-System CPU and other components

Place the CX-block onto a suitable support with the front facing down. Then insert a flat screwdriver with dimensions 1.0 x 5.5 x 150 mm into the locking mechanism, and then operating the slider by turning it about 90 degrees. The locking mechanism on the rear affects an approx. 2-3 mm wide clearance of the module latching mechanism, pushing them apart. The plug connectors of the PC 104 interface can then be pulled apart carefully.

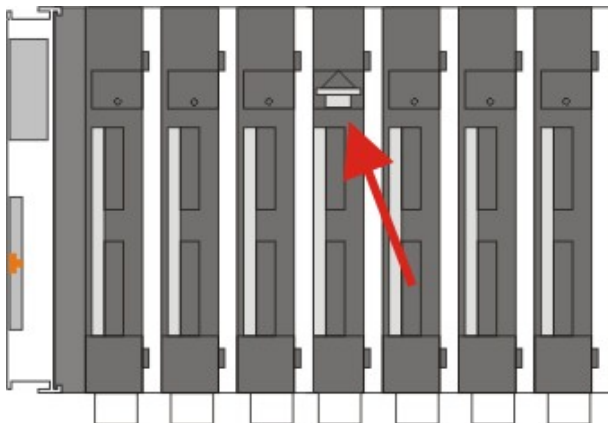

Only modules (CPU, fieldbus connections and UPS modules) that can be separated non-destructively feature a release device. Modules that cannot be separated only feature a marking point (with or without red paint seal). Applying force to these elements will destroy them.

 Attention	<p>Forcibly opening the module housing</p> <p>Forcibly opening the module housing (e.g. removing the cover) will destroy the housing.</p>
---	--

Disposal

The device must be fully dismantled in order to dispose of it.

Electronic parts must be disposed of in accordance with national electronics scrap regulations.

7 Appendix

7.1 CX90x0 : Update Image

General

 Note	Image update In general an update of the image is not necessary : The basic functionality of TwinCAT and TwinCAT PLC are working fine. Update the Image ONLY if there is an advice from BECKHOFF Automation GmbH. Never change a running system !
--	---

If the image update is required, here some basic information for overview:

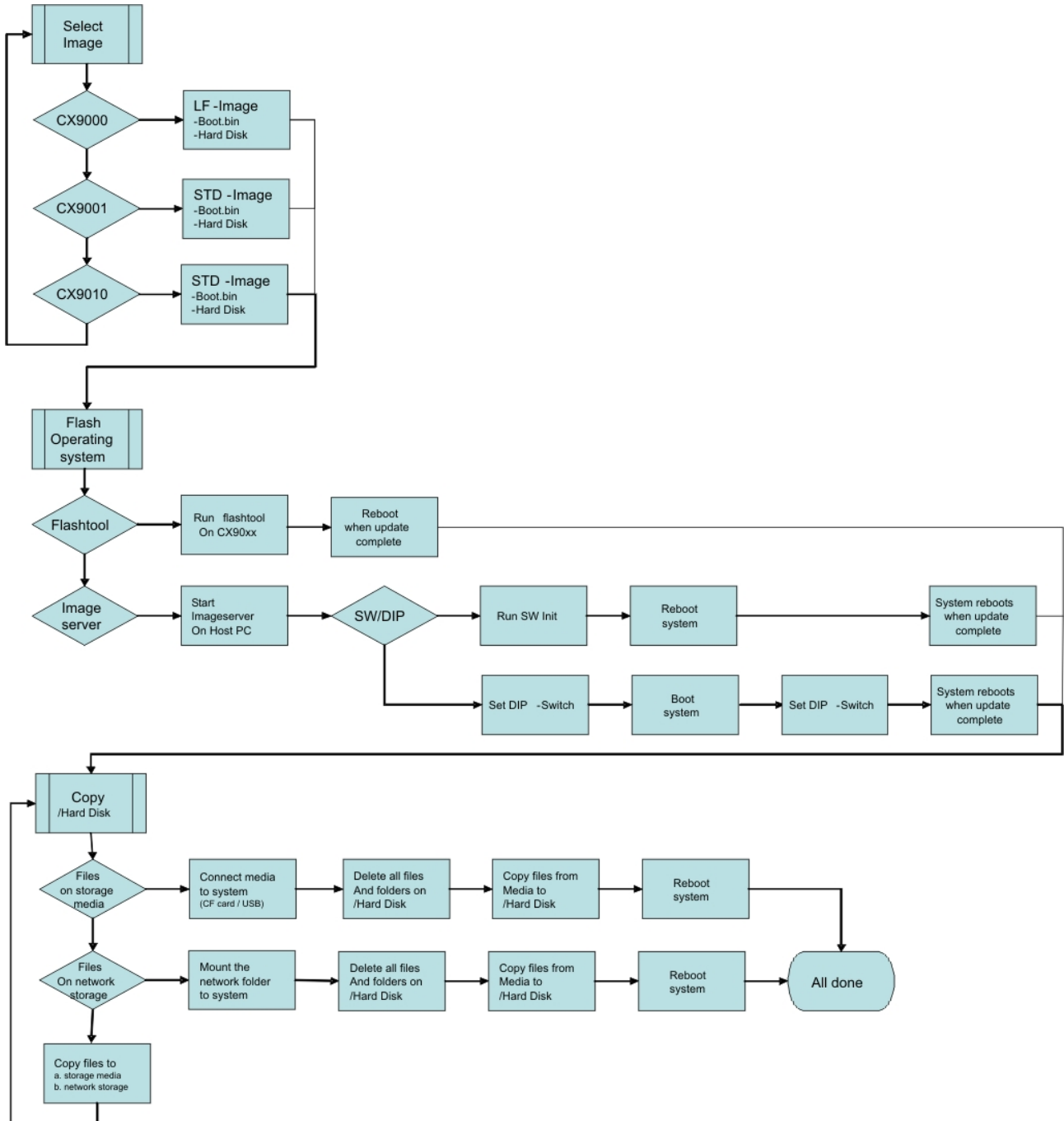

The diagram shows the flow of the update process. There are three main steps:

FTP-Directory /Software/embPC-Control/CX9000/CE/ auf ftp.beckhoff.de.

```
Beckhoff FTP Server ftp.beckhoff.com
No unauthorised access to our systems is allowed!
Please report operational problems to webadmin@beckhoff.com
```

```
<DIR> ..
10/17/11 09:55AM [GMT] 6,735,682 CX9000_CE500_LF_v226.zip
10/17/11 09:55AM [GMT] 8,971,992 CX9000_CE600_LF_v312.zip
02/23/11 06:46PM [GMT] 98,959 CX9000_ImageUpdate.zip
```

[CX9000 ImageUpdate.zip](#) [CX9000 CE600 LF v312.zip](#) [CX9000 CE500 LF v226.zip](#) ..

CX9000_CE500_LF_v226.zip

Image for CE5.0

CX9000_CE600_LF_v312.zip

Image for CE6.0

CX9000_ImageUpdate.zip

Image-server and Enable Update-Tool for Update via the Update-Server and Update-Tool for direct update.

For CX9001 and CX9010 select link CX90xx.

FTP-Directory /Software/embPC-Control/CX90xx/CE/ on ftp.beckhoff.de.

```
Beckhoff FTP Server ftp.beckhoff.com
No unauthorised access to our systems is allowed!
Please report operational problems to webadmin@beckhoff.com
```

```
<DIR> ..
02/23/11 06:46PM [GMT] 98,959 CX9000_ImageUpdate.zip
09/22/08 12:32PM [GMT] 5,278,516 CX90x0_NoHive_32MB_Flash.zip
10/17/11 09:55AM [GMT] 15,903,461 CX90xx_CE500_HMI_v226.zip
10/17/11 09:56AM [GMT] 19,347,515 CX90xx_CE600_HPS_v312.zip
```

[CX90xx CE600 HPS v312.zip](#) [CX90xx CE500 HMI v226.zip](#) [CX90x0 NoHive 32MB Flash.zip](#)
[CX9000 ImageUpdate.zip](#) ..

CX90xx_CE500_HMI_v226.zip

Image for CE5.0

CX90xx_CE600_HPS_v312.zip

Image for CE6.0

CX90x0_NoHive_32MB-Flash.zip

empty image to delete /Hard Disk

CX9000_ImageUpdate.zip

Image-server and Enable Update-Tool for Update via the Update-Server.

Flashing operating system

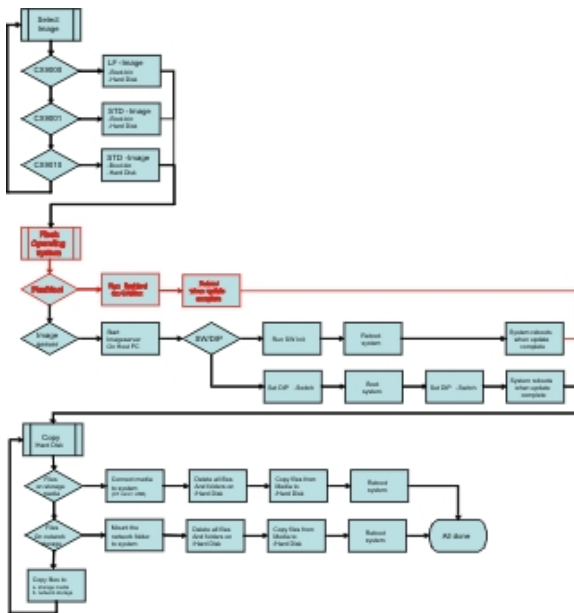

Interactive tool on CX90x0:

First the program "Cx9ImageUpdate.exe" must be downloaded from BECKHOFF FTP-Server. If the CX90x0 has no USB the tool can be transferred via ftp onto the system. Use [CERHOST-Tools](#) to control the CX90x0 remote via Ethernet. Activate the FTP server on the CX, if not it is disabled. The necessary configuration is shown below:

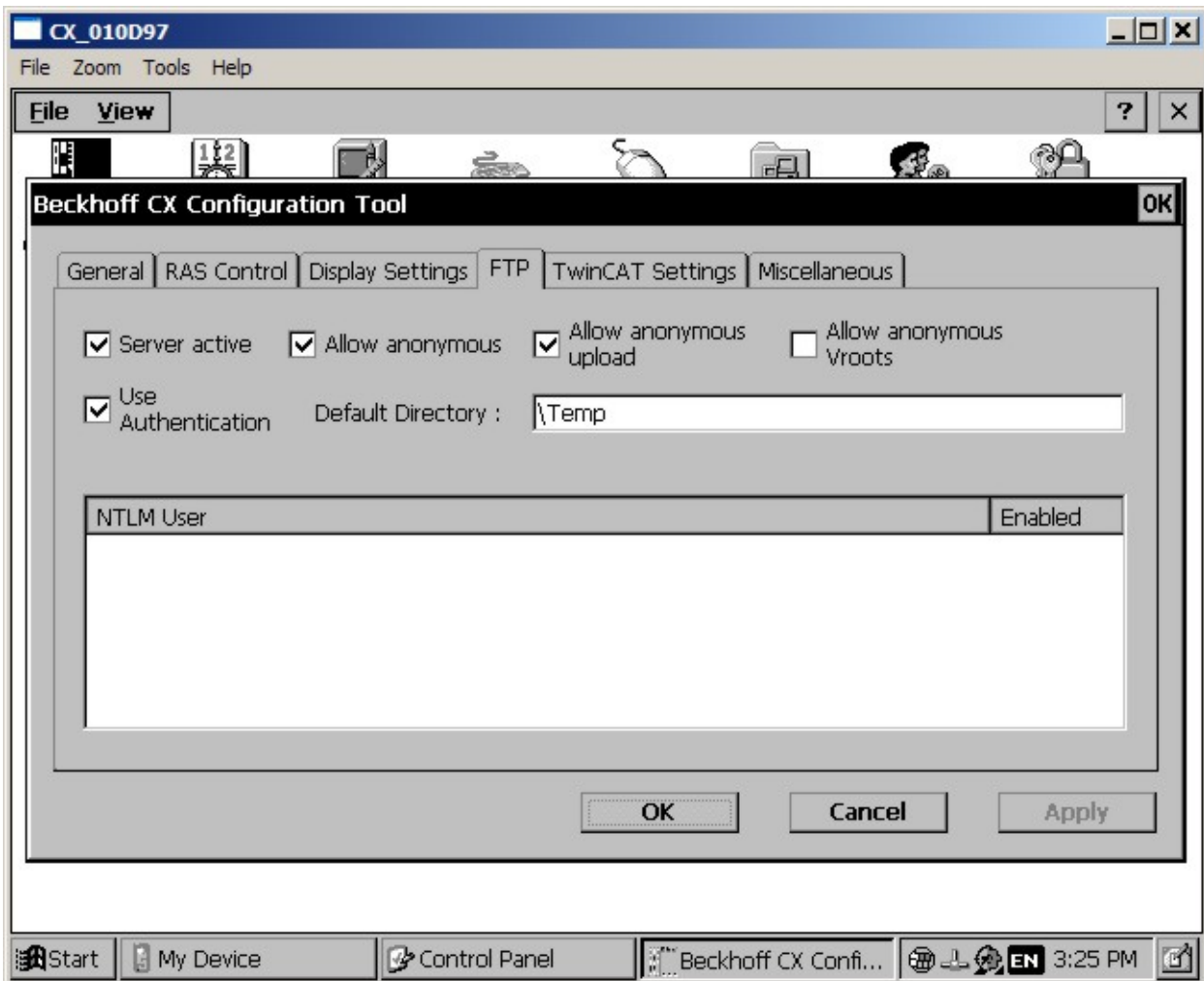

It is a good idea to choose "\\Temp" or "\\Public" as target directory, though this range is mapped into the RAM regions instead of the hard disc located in flash memory. For operation the system must be rebooted. Just follow the instructions on the screen. After restart of the CX90x0 the program can be copied easily to the CX90x0 with the explorer:

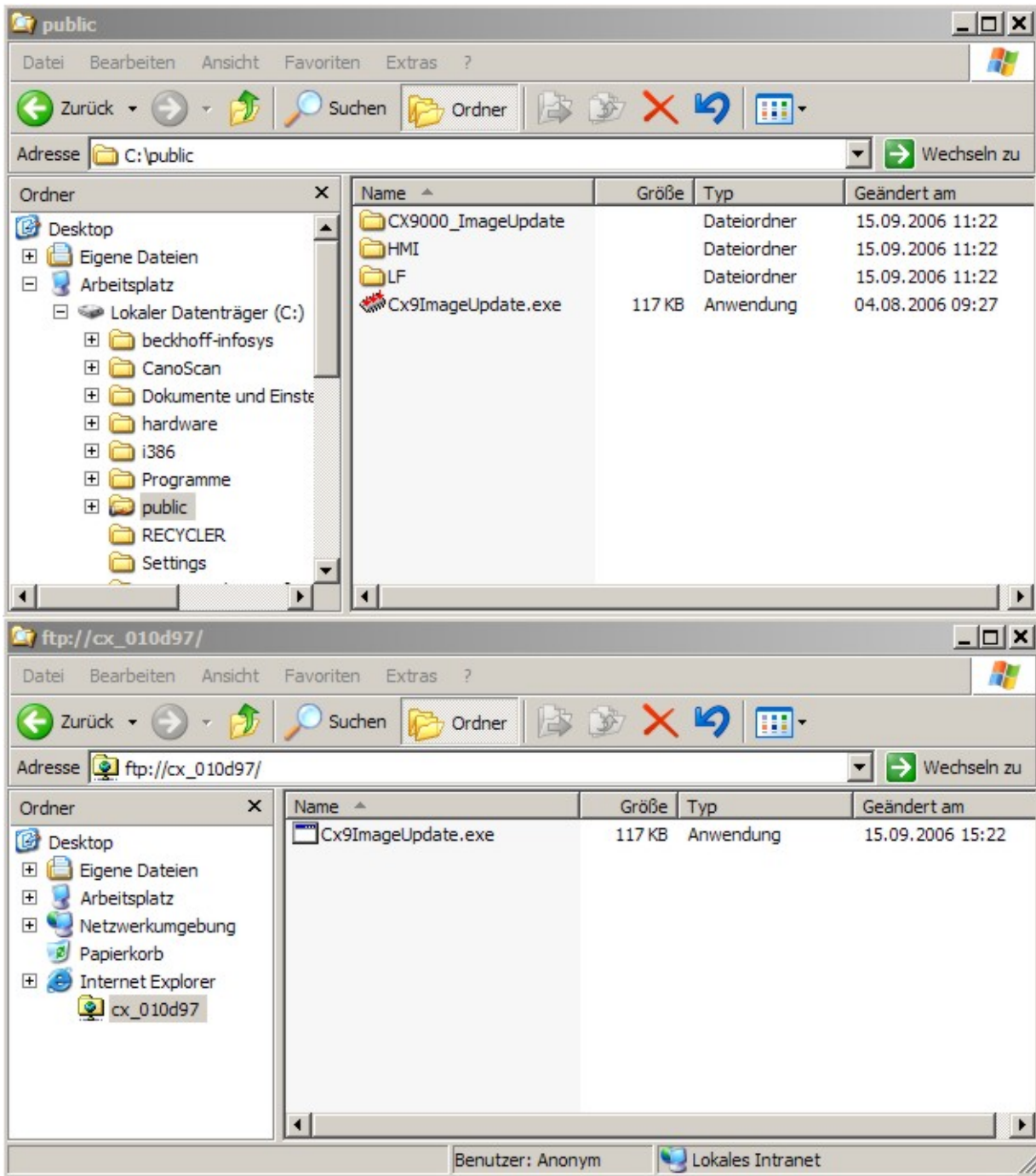

If there is enough free space on the CX90x0 (big memory) the image can be copied together with to tool. Otherwise the image file can be accessed via network drive. In this case you should map the drive to the CX90x0:

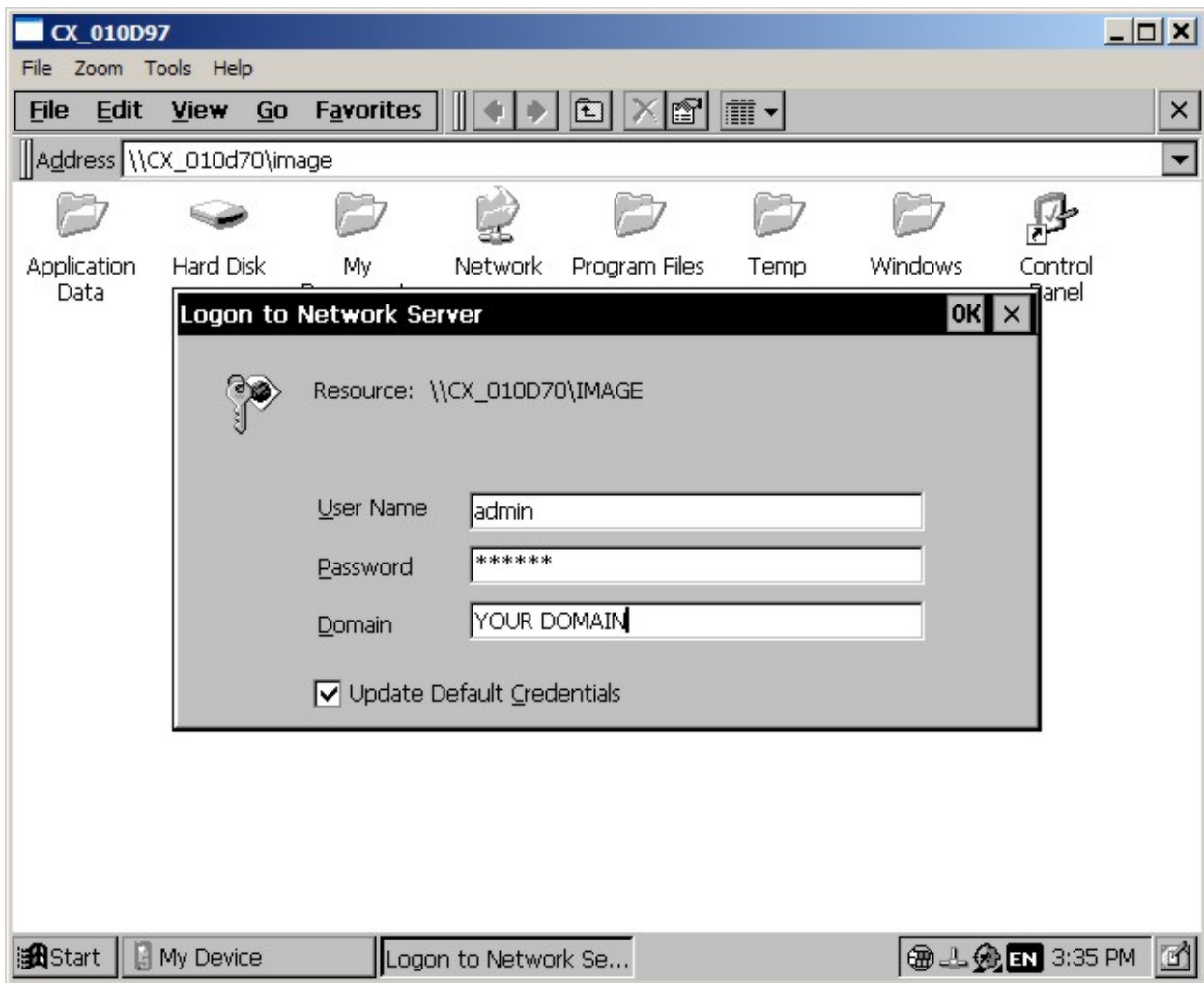

If the image is copied to the CX90x0 or the network drive is mapped to the system the update tool can be started by double click on the icon. The program ask for the filename of the image. The complete path to the file must be entered now. Depending on the network configuration the password is requested again.

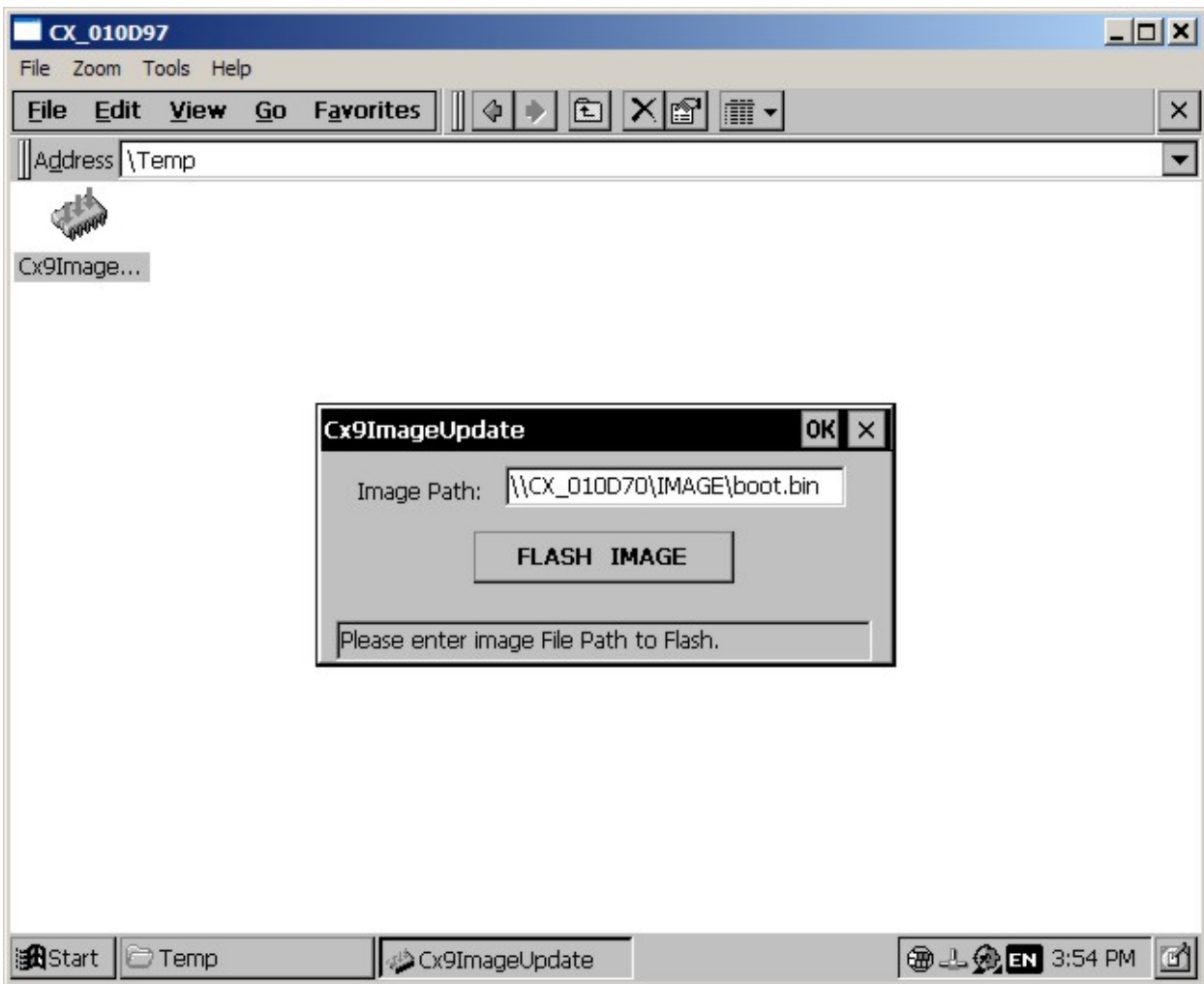

After click on "FLASH IMAGE" button a request box appears to confirm the image file. This is the last chance to abort the update process.

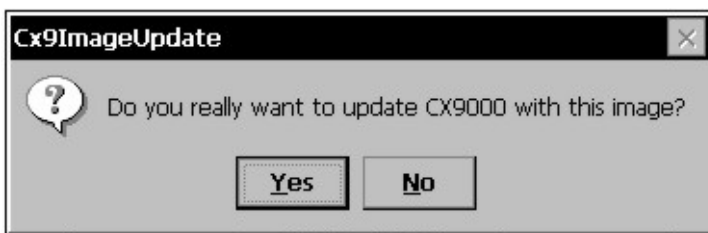

When confirming the image file a warning appears on the screen.

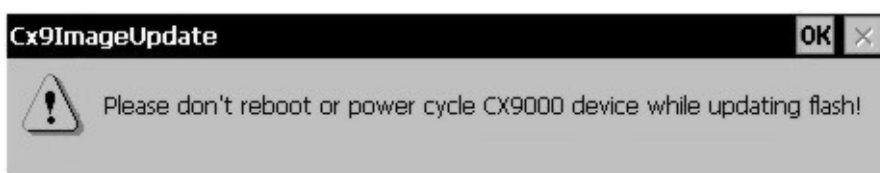

The progress is shown in the status line in the bottom of the tool.

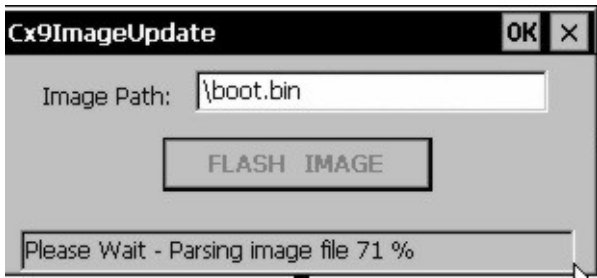

When the update is complete the following message appears in the status field:



The CX90x0 can be rebooted now. If the system has started again The last step can be done.

Imageserver on Host PC

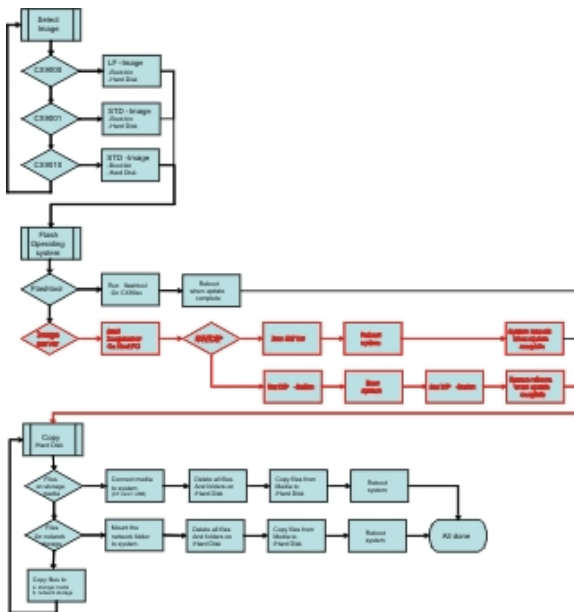

1. Prepare Image-Server (once)

Provide the image server on the host PC, the components are :

- Two batchfiles "CxImgSrv_HMI.bat" and "CxImgSrv_LF.bat"
Note that the CX90x0 is shipped with different hardware environment (e.g. more or less flash memory).
- Folder "\Tools" contains the image server itself : CxImageSrv.exe
- Folder "\Images" contains the HMI and LF subfolders with the required file "Boot.bin"
If you receive a new NK.BIN file, just rename it to "Boot.bin" and provide it in the correct subfolder

2. Prepare CX90x0

Prepare the "Boot-Strap Mode" on CX90x0. There are two ways to set the CX90x0 into "Boot-Strap Mode":

First the DIP-switch version is described.

1. Power down the CX90x0.
2. Open the battery compartment (located between two ethernet ports)
It can be opened with the aid of a screwdriver (proceed carefully in order to avoid damage).

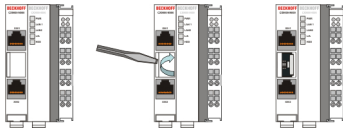

3. If the clack is opened, you can access to the four Dip switches. They are placed on the left side of the battery mount. In the normal operation state all switches are set to OFF (all switches are placed down).



To change the settings, use a screw driver with a short top (2.5 mm x 7.5 mm length and parallel top, Beckhoff order number ZB8700). Be careful with the top, don't damage the device. Find the dip switches 1,2,3,4 and set switch 3 from OFF to ON (switch 3 placed top). If the Dip Switches are protected with a foil, it's necessary to breakthrough that foil.



Start a program, that sets the CX90x0 in the "Boot-Strap Mode".

Alternative the administrator can start a tool on the CX-Systems to set the CX90x0 into "Boot-Strap Mode". First the program must be downloaded from the BECKHOFF FTP-Server. If the CX90x0 has no USB the tool can be transferred via ftp onto the system. Use [CERHOST-Tools](#) to control the CX90x0 remote via Ethernet. Activate the FTP server on the CX, if not it is disabled. The necessary configuration is shown below:

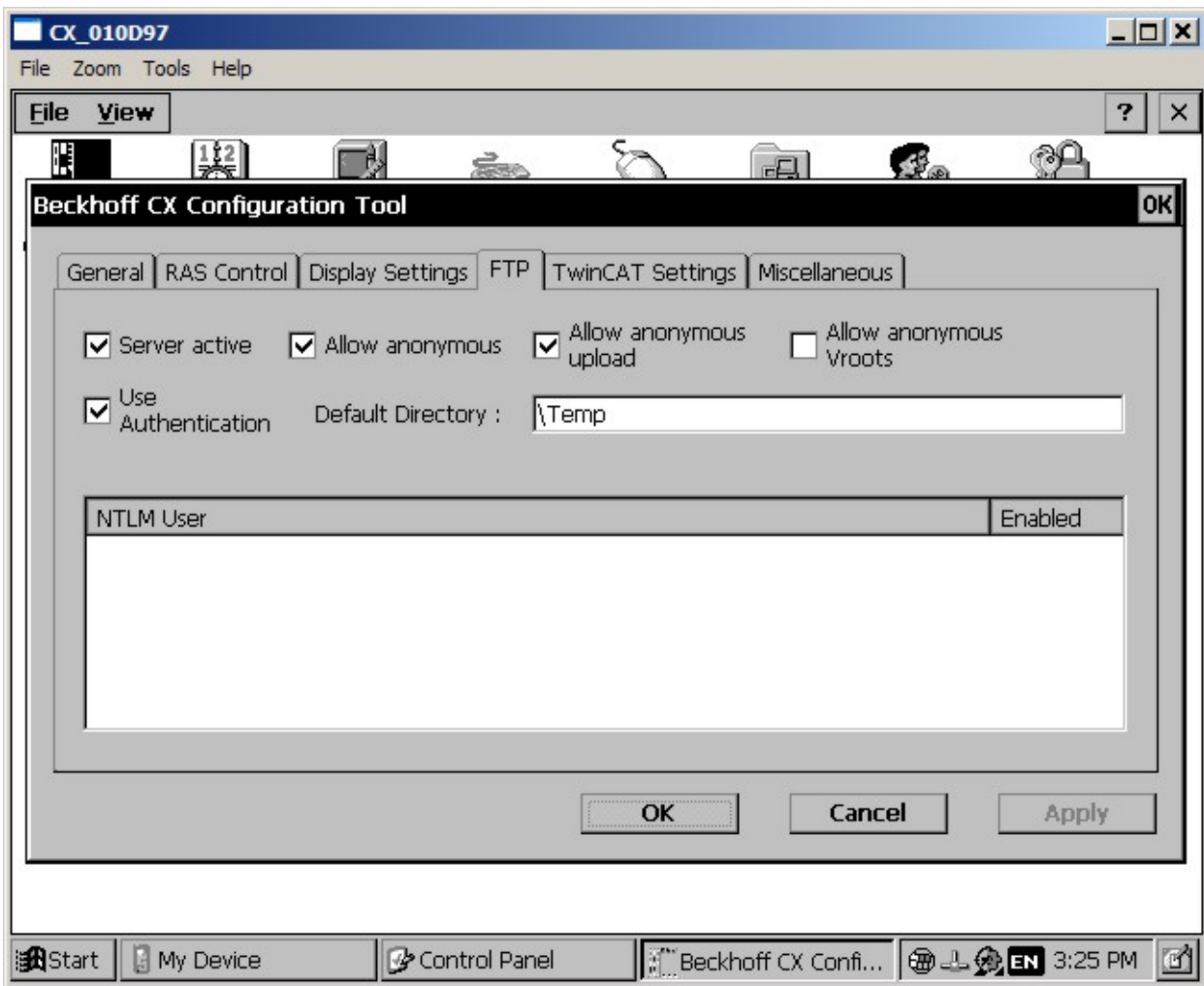

It is a good idea to choose "\\Temp" or "\\Public" as target directory, though this range is mapped into the RAM regions instead of the hard disc located in flash memory. For operation the system must be rebooted. Just follow the instructions on the screen. After restart of the CX90x0 the program can be copied easily to the CX90x0 with the explorer:

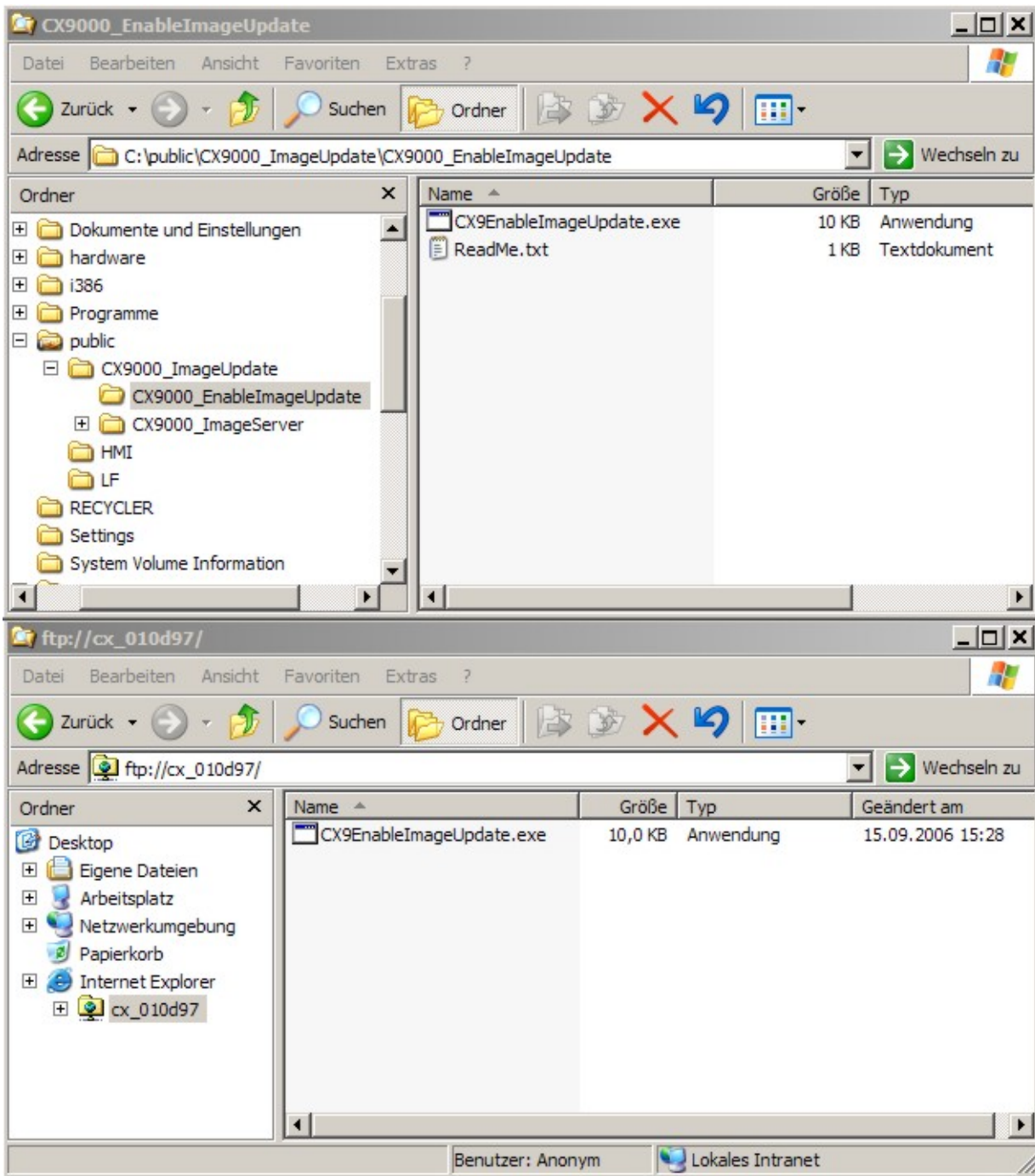

Attention

Starting CERHOST

Via CERHOST the program will be started with a double click on the icon. Warning: Do NOT start the program if you have no image-Server (see below) AND a correct image! The CX90x0 is now no longer useable for PLC until an update was made!The reset to operational is done automatically if the the update has taken place.



Note

Image Server

Image server will listen in complete network to be contacted by CX90x0 Two solutions to be sure that you just update your CX90x0 device.... and not others in network ! (for details see network notes below)

4. Start image server

Start the image server on the host PC :

- start the correct batch file "CxImgSrv_HMI.bat" or "CxImgSrv_LF.bat" (to let image-server provide the HMI or the LF image in network)

The batch file will start a command-shell and prompt : **"Waiting for download request..."**

5. Phases during image update

Start CX90x0 to initiate the download procedure :

- Initial phase :
 Start CX90x0 to initiate the download procedure :power on CX90x0
 The CX90x0 tries to find an image server on network to download an image.
- Download phase :
 Image server will prompt a message in command shell if an image is downloaded to CX90x0

Message is like :

Boot image request from device CX90x0_BA23
Working directory is Image\HMI
Calling TFTP.exe -i <CX90x0-IP> PUT boot.bin

On CX90x0 the HDD led will light up : The CX- device is erasing and copying new image.

- Reorganisation phase :
 The image server will prompt a message, that the download of new image has been finished.
 Now, close command shell. (Press <CTRL> + <c> or close the window)
- **Set system back to operation mode; to avoid the system to run the update procedure again. Set the dip switch 3 back to "off" and close the battery compartment.**



NOTES on network configuration :

- Image server will listen in complete network to be contacted by CX90x0
 Two solutions to be sure that you just update your CX90x0 device.... and not others in network !

1a.
 provide a subnet (like a second network card in host PC)

or

1b.
 connect host-pc and CX90x0 directly without involving company network

or

2.
 The image server can be configured to let CX directly request image from specific IP address.
 Step 1 : connect CX90x0 with PC, get IP address of PC like **192.16.18.123**
 Step 2 : edit the image-server-batch-file and add the IP address to the command line. (Sample : **Tools\CxImageSrv Images\HMI 192.16.18.123**)
 Step 3 : proceed with booting CX90x0 in boot strap mode. Now the CX will try do request image from IP address 192.16.18.123

Copy files to Harddisk

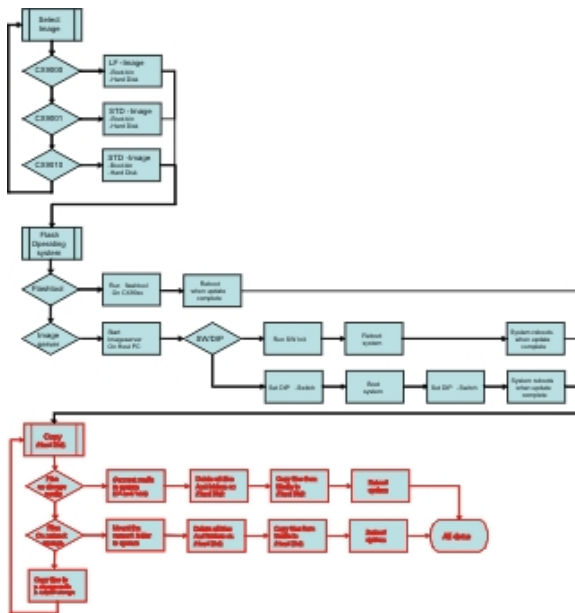

To make the new image work perfectly new configuration and program files are needed. They must be copied to the internal flash. There are two ways to make the files accessible to the system. If the system consists of interfaces CX9000-N010 or CX9000-N070 a USB-stick can hold the files. The system interface CX9000-A001 can make the files available via a CF-card. If there are none of the suggested system interfaces the files must be made available via a network drive (see above)

Next step is to delete the files on the internal flash. To do so just delete all files on "/Hard Disk". All files that can not be deleted must be renamed.

Now all files from the archive can be copied to the "Hard Disk". When all files are copied reboot the system.

The renamed files can be deleted and the update is complete.

7.2 Accessories

Compact flash cards

Order number for the initial order of a compact flash card (instead of the 128 MB compact flash card)

Order number	Description
CX1900-0023	1 GB compact flash card, extended temperature range, instead of 128 MB compact flash card
CX1900-0025	2 GB compact flash card, extended temperature range, instead of 128 MB compact flash card
CX1900-0027	4 GB compact flash card, extended temperature range, instead of 128 MB compact flash card
CX1900-0029	8 GB compact flash card, extended temperature range, instead of 128 MB compact flash card
CX1900-0031	16 GB compact flash card, extended temperature range, instead of 128 MB compact flash card

Spare compact flash cards

Order number	Description
CX1900-0022	128 MB compact flash card, extended temperature range
CX1900-0024	1 GB compact flash card, extended temperature range
CX1900-0026	2 GB compact flash card, extended temperature range
CX1900-0028	4 GB compact flash card, extended temperature range
CX1900-0030	8 GB compact flash card, extended temperature range
CX1900-0032	16 GB compact flash card, extended temperature range

Formatting options

Order number	Description
CX1900-0010	Formatting a compact flash card (bootable) FAT16
CX1900-0012	Formatting a compact flash card (bootable) NTFS

Connectors and Adaptors

Order number	Description
CX1900-0101	DVI-to-VGA passive Adaptor for connecting a standard desktop VGA monitor to the CX1000 system – singles out the VGA signals of the DVI-I interface of the CX1000-N001 module – 29-pin male DVI-A connector (bottom) to 15-pin female connector (top) – weight approx. 40 g – dimensions (W x H x D) 40 x 42 x 15 mm

Spare battery

Order number	Description
CX1900-0102	Battery for the CX-Systems - original product description: Panasonic type CR2032 3V/225mAh

7.3 Certifications

All products of the Embedded PC family are CE, UL and GOST-R certified. Since the product family is continuously developed further, we are unable to provide a full listing here. The current list of certified products can be found at www.beckhoff.com.

FCC Approvals for the United States of America

FCC: Federal Communications Commission Radio Frequency Interference Statement

This equipment has been tested and found to comply with the limits for a Class A digital device, pursuant to Part 15 of the FCC Rules. These limits are designed to provide reasonable protection against harmful interference when the equipment is operated in a commercial environment. This equipment generates, uses, and can radiate radio frequency energy and, if not installed and used in accordance with the instruction manual, may cause harmful interference to radio communications. Operation of this equipment in a residential area is likely to cause harmful interference in which case the user will be required to correct the interference at his own expense.

FCC Approval for Canada

FCC: Canadian Notice

This equipment does not exceed the Class A limits for radiated emissions as described in the Radio Interference Regulations of the Canadian Department of Communications.

7.4 Support and Service

Beckhoff and their partners around the world offer comprehensive support and service, making available fast and competent assistance with all questions related to Beckhoff products and system solutions.

Beckhoff's branch offices and representatives

Please contact your Beckhoff branch office or representative for local support and service on Beckhoff products!

The addresses of Beckhoff's branch offices and representatives round the world can be found on her internet pages:

<http://www.beckhoff.com>

You will also find further documentation for Beckhoff components there.

Beckhoff Headquarters

Beckhoff Automation GmbH & Co. KG

Huelshorstweg 20
33415 Verl
Germany

Phone:	+49(0)5246/963-0
Fax:	+49(0)5246/963-198
e-mail:	info@beckhoff.com

Beckhoff Support

Support offers you comprehensive technical assistance, helping you not only with the application of individual Beckhoff products, but also with other, wide-ranging services:

- support
- design, programming and commissioning of complex automation systems
- and extensive training program for Beckhoff system components

Hotline:	+49(0)5246/963-157
Fax:	+49(0)5246/963-9157
e-mail:	support@beckhoff.com

Beckhoff Service

The Beckhoff Service Center supports you in all matters of after-sales service:

- on-site service
- repair service
- spare parts service
- hotline service

Hotline:	+49(0)5246/963-460
Fax:	+49(0)5246/963-479
e-mail:	service@beckhoff.com