

**BECKHOFF** New Automation Technology

Manual | EN

# CX2500-0062

2.5 Gbit Ethernet module for CX20xx, CX52x0, CX53x0, CX56x0





# Table of contents

<b>1</b>	<b>Notes on the documentation</b> .....	<b>5</b>
1.1	Representation and structure of warnings .....	6
1.2	Documentation issue status .....	7
<b>2</b>	<b>For your safety</b> .....	<b>8</b>
2.1	Intended use .....	8
2.2	Staff qualification .....	8
2.3	Safety instructions .....	8
2.4	Notes on information security .....	9
<b>3</b>	<b>Product overview</b> .....	<b>10</b>
3.1	Structure .....	10
3.2	Ethernet interfaces (X620, X621) .....	11
<b>4</b>	<b>Mounting</b> .....	<b>13</b>
4.1	Plug in extension module .....	13
4.2	Installing the housing locking clips .....	14
<b>5</b>	<b>Error handling and diagnostics</b> .....	<b>15</b>
5.1	LEDs on the Ethernet system interface .....	15
5.2	Faults .....	15
<b>6</b>	<b>Technical data</b> .....	<b>16</b>
<b>7</b>	<b>Appendix</b> .....	<b>17</b>
7.1	Accessories .....	17
7.2	Certifications .....	18
7.3	Support and Service .....	19
	<b>List of tables</b> .....	<b>20</b>
	<b>List of figures</b> .....	<b>21</b>



# 1 Notes on the documentation

This description is intended exclusively for trained specialists in control and automation technology who are familiar with the applicable national standards.

For installation and commissioning of the components, it is absolutely necessary to comply with the documentation and the following notes and explanations.

The qualified personnel is always obliged to use the currently valid documentation.

The responsible staff must ensure that the application or use of the products described satisfies all safety requirements, including all the relevant laws, regulations, guidelines, and standards.

## Disclaimer

The documentation has been prepared with care. The products described are, however, constantly under development.

We reserve the right to revise and change the documentation at any time and without notice.

No claims to modify products that have already been supplied may be made on the basis of the data, diagrams, and descriptions in this documentation.

## Trademarks

Beckhoff®, TwinCAT®, TwinCAT/BSD®, TC/BSD®, EtherCAT®, EtherCAT G®, EtherCAT G10®, EtherCAT P®, Safety over EtherCAT®, TwinSAFE®, XFC®, XTS® and XPlanar® are registered and licensed trademarks of Beckhoff Automation GmbH.

If third parties make use of designations or trademarks used in this publication for their own purposes, this could infringe upon the rights of the owners of the said designations.

## Patents

The EtherCAT Technology is covered by the following patent applications and patents, without this constituting an exhaustive list:

EP1590927, EP1789857, EP1456722, EP2137893, DE102015105702

and similar applications and registrations in several other countries.

**EtherCAT** 

EtherCAT® is registered trademark and patented technology, licensed by Beckhoff Automation GmbH, Germany

## Copyright

© Beckhoff Automation GmbH & Co. KG, Germany.

The distribution and reproduction of this document, as well as the use and communication of its contents without express authorization, are prohibited.

Offenders will be held liable for the payment of damages. All rights reserved in the event that a patent, utility model, or design are registered.

## 1.1 Representation and structure of warnings

The following warnings are used in the documentation. Read and follow the warnings.

### Warnings relating to personal injury:

 **DANGER**

Hazard with high risk of death or serious injury.

 **WARNING**

Hazard with medium risk of death or serious injury.

 **CAUTION**

There is a low-risk hazard that can result in minor injury.

### Warnings relating to damage to property or the environment:

**NOTICE**

There is a potential hazard to the environment and equipment.

### Notes showing further information or tips:



This notice provides important information that will be of assistance in dealing with the product or software. There is no immediate danger to product, people or environment.

## 1.2 Documentation issue status

Version	Changes
1.0	First version

## 2 For your safety

Read the chapter on safety and follow the instructions in order to protect from personal injury and damage to equipment.

### Limitation of liability

All the components are supplied in particular hardware and software configurations appropriate for the application. Unauthorized modifications and changes to the hardware or software configuration, which go beyond the documented options, are prohibited and nullify the liability of Beckhoff Automation GmbH & Co. KG.

In addition, the following actions are excluded from the liability of Beckhoff Automation GmbH & Co. KG:

- Failure to comply with this documentation.
- Improper use.
- Use of untrained personnel.
- Use of unauthorized replacement parts.

## 2.1 Intended use

The 2.5 Gbit Ethernet module CX2500-0062 is an extension module for the CX20x2, CX20x3, CX52x0, CX53x0 and CX56x0 Embedded PC series. The CX2500-0062 extension module is used to integrate additional interfaces into the system and is connected to the left of the basic CPU module via a multi-pin connector. For the CX20x2 and CX20x3 series, up to four extension modules can be connected in any order, while for the CX52x0, CX53x0 and CX56x0 series, only one extension module can be connected at a time.

Together with an embedded PC, the extension module is designed for installation in a control cabinet or terminal box and meets the IP20 protection rating. This means:

- It is protected against the penetration of fingers and solid foreign bodies of 12.5 mm or larger in size.
- It is not protected against water.

Operation of the devices in wet and dusty environments is not permitted, unless specified otherwise. The specified limits for electrical and technical data must be adhered to.

The extension module is not suitable for operation in the following areas:

### Improper use

- Hazardous area.
- Areas with an aggressive environment, e.g. aggressive gases or chemicals.
- Living areas. In living areas, the relevant standards and guidelines for interference emissions must be adhered to, and the devices must be installed in housings or control boxes with suitable attenuation of shielding.

## 2.2 Staff qualification

All operations involving Beckhoff software and hardware may only be carried out by qualified personnel with knowledge of control and automation engineering. The qualified personnel must have knowledge of the administration of the Industrial PC and the associated network.

All interventions must be carried out with knowledge of control programming, and the qualified personnel must be familiar with the current standards and guidelines for the automation environment.

## 2.3 Safety instructions

The following safety instructions must be followed during installation and working with networks and the software.



## Mounting

- Never work on live equipment. Always switch off the power supply for the device before installation, troubleshooting or maintenance. Protect the device against unintentional switching on.
- Observe the relevant accident prevention regulations for your machine (e.g. the BGV A 3, electrical systems and equipment).
- Ensure standard-compliant connection and avoid risks to personnel. Ensure that data and supply cables are laid in a standard-compliant manner and ensure correct connection.
- Observe the relevant EMC guidelines for your application.
- Avoid polarity reversal of the data and supply cables, as this may cause damage to the equipment.
- The devices contain electronic components, which may be destroyed by electrostatic discharge when touched. Observe the safety precautions against electrostatic discharge according to DIN EN 61340-5-1/-3.

## Working with networks

- Restrict access to all devices to an authorized circle of persons.
- Change the default passwords to reduce the risk of unauthorized access.
- Protect the devices with a firewall.
- Apply the IT security precautions according to IEC 62443, in order to limit access to and control of devices and networks.

## Working with the software

- The sensitivity of a PC against malicious software increases with the number of installed and active software.
- Uninstall or disable unnecessary software.

Further information on the safe handling of networks and software can be found in the Beckhoff Information System:

<http://infosys.beckhoff.com>

Document name
IPC Security Guideline

## 2.4 Notes on information security

The products of Beckhoff Automation GmbH & Co. KG (Beckhoff), insofar as they can be accessed online, are equipped with security functions that support the secure operation of plants, systems, machines and networks. Despite the security functions, the creation, implementation and constant updating of a holistic security concept for the operation are necessary to protect the respective plant, system, machine and networks against cyber threats. The products sold by Beckhoff are only part of the overall security concept. The customer is responsible for preventing unauthorized access by third parties to its equipment, systems, machines and networks. The latter should be connected to the corporate network or the Internet only if appropriate protective measures have been set up.

In addition, the recommendations from Beckhoff regarding appropriate protective measures should be observed. Further information regarding information security and industrial security can be found in our <https://www.beckhoff.com/secguide>.

Beckhoff products and solutions undergo continuous further development. This also applies to security functions. In light of this continuous further development, Beckhoff expressly recommends that the products are kept up to date at all times and that updates are installed for the products once they have been made available. Using outdated or unsupported product versions can increase the risk of cyber threats.

To stay informed about information security for Beckhoff products, subscribe to the RSS feed at <https://www.beckhoff.com/secinfo>.

### 3 Product overview

The CX2500-0062 module provides two independent Ethernet interfaces. The Intel®-i226 Ethernet controller used supports data transfer rates of up to 2.5 Gbit/s. This makes the module interesting for applications that require particularly high data rates and short reaction times.

The extension modules are connected on the left-hand side of the basic CPU module via a multi-pin connector. A maximum of four CX2500-xxxx modules can be plugged into the CX20xx series in any order, and one module can be plugged into the CX52x0, CX53x0 or CX56x0 series.

#### Scope of supply

The extension module is supplied by default with a protective cap for the left-hand multi-pin connector and two housing locking clips. The housing locking clips are used to securely connect the housing of the extension module to the embedded PC after installation.

#### 3.1 Structure



Fig. 1: Structure of a CX2500-0062 extension module.

Table 1: Legend for the structure.

No.	Component	Description
1	Ethernet interfaces RJ45 (X600, X601)	2 x RJ45, 10/100/1000/2500 Mbit/s
2	Multi-pin connection, left	Connector under the protective cap, for connecting additional modules, only for CX20xx series. The CX20xx series supports a maximum of four CX2500-xxxx modules
3	Multi-pin connection, right	Connector for connection to a basic CPU module.

### 3.2 Ethernet interfaces (X620, X621)

The two Ethernet interfaces are independent of each other and no switch is integrated. The independent Ethernet interfaces can be configured differently. Note that an additional switch is required for a line topology.

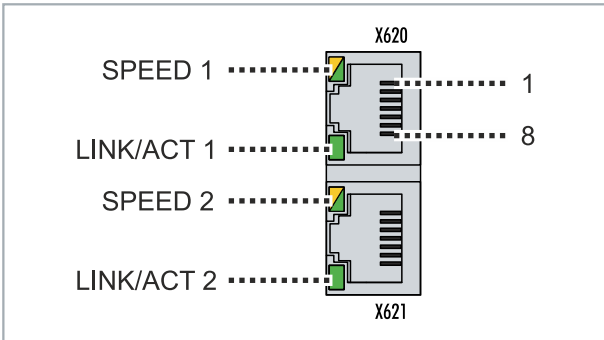

Fig. 2: Ethernet interface (X620, X621)

Both Ethernet interfaces achieve speeds of 10/100/1000/2500 Mbit/s. The LEDs on the left-hand side of the interfaces indicate the connection status. The lower LED (LINK/ACT) indicates whether the interface is connected to a network. If this is the case, the LED lights up green. The LED flashes when data transmission is in progress on the interface.

The upper LED (SPEED) indicates the connection speed. At a speed of 10/100 Mbit/s, the LED does not light up. At a speed of 1000 Mbit/s, the LED lights up yellow. At 2500 Mbit/s the LED lights up green.

Table 2: Ethernet interface X620 and X621, pin assignment.

PIN	Signal	Description
1	T2 +	Pair 2
2	T2 -	
3	T3 +	Pair 3
4	T1 +	
5	T1 -	Pair 3
6	T3 -	
7	T4 +	Pair 4
8	T4 -	

#### Display in the Device Manager

By default, the Ethernet interfaces are identified as follows in the Device Manager:

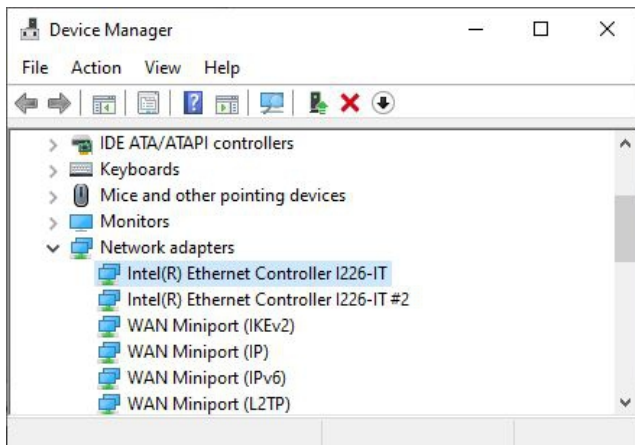

Fig. 3: Designation of Ethernet interfaces in the Device Manager.

## Jumbo Frames

Standardized Ethernet frames have a size of 1518 bytes. Ethernet frames that are larger than 1518 bytes are referred to as jumbo frames. Jumbo frames are used for transferring large data quantities. Jumbo frames are useful for certain applications, e.g. video cameras.

Requirements:

- Check whether the peripherals used support jumbo frames.

### Proceed as follows:

1. Start the Device Manager.
2. Double-click on an interface and then on the **Advanced** tab.

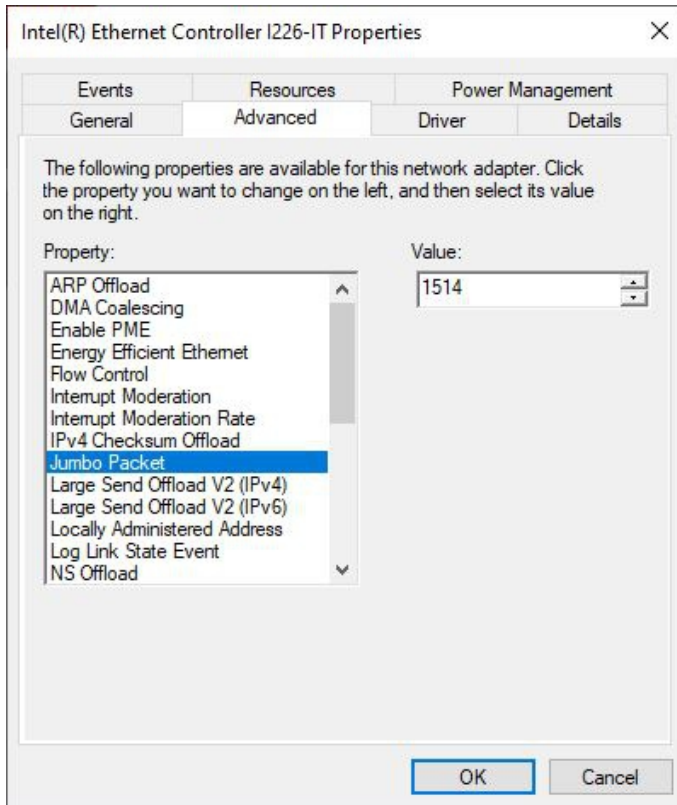

3. Under **Property** click on Jumbo Packet and under **Value** click on the option 4088 Bytes or 9014 Bytes.

## 4 Mounting

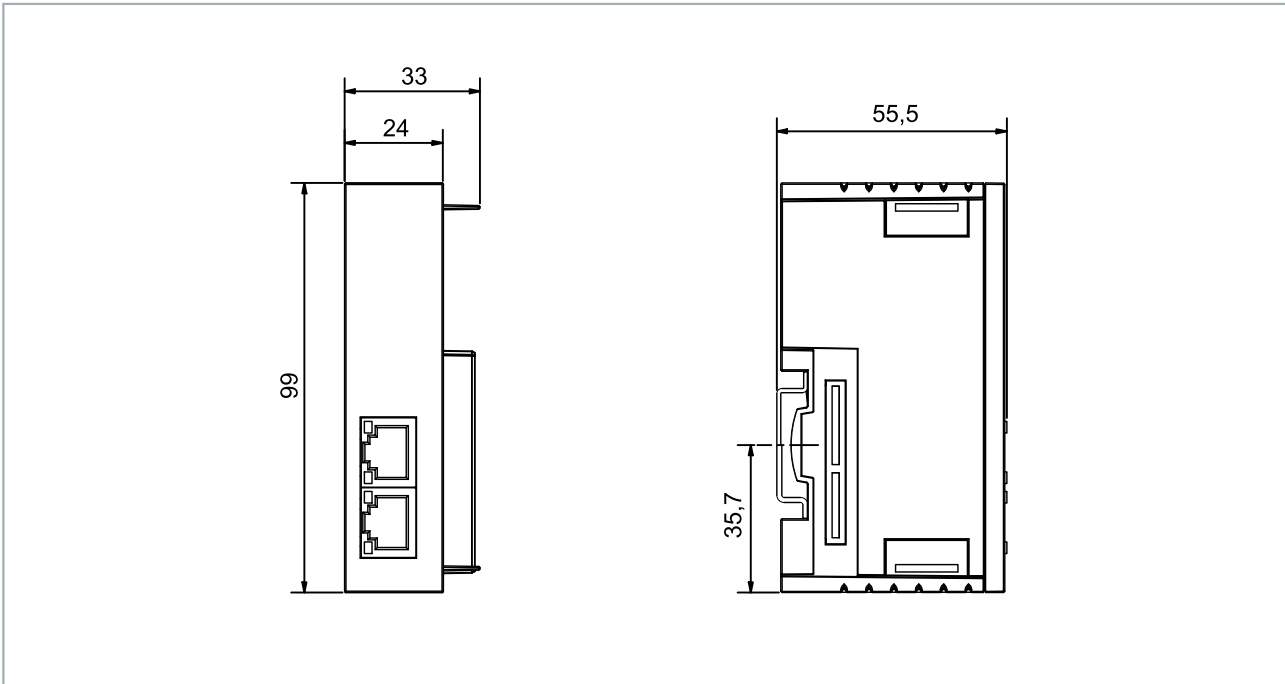

Fig. 4: CX2500-0062 extension module, dimensions

### 4.1 Plug in extension module

The extension module is connected to the left-hand side of the basic CPU module via a multi-pin connector.

A maximum of four CX2500-xxxx modules can be plugged into the CX20xx series in any order, and one module can be plugged into the CX52x0, CX53x0 or CX56x0 series.

**Proceed as follows:**

1. The left-hand multi-pin connection of a basic CPU module is fitted with a protective cap ex factory. Remove the protective cap from the basic CPU module.
2. Plug the extension module into the left-hand side of the basic CPU module.

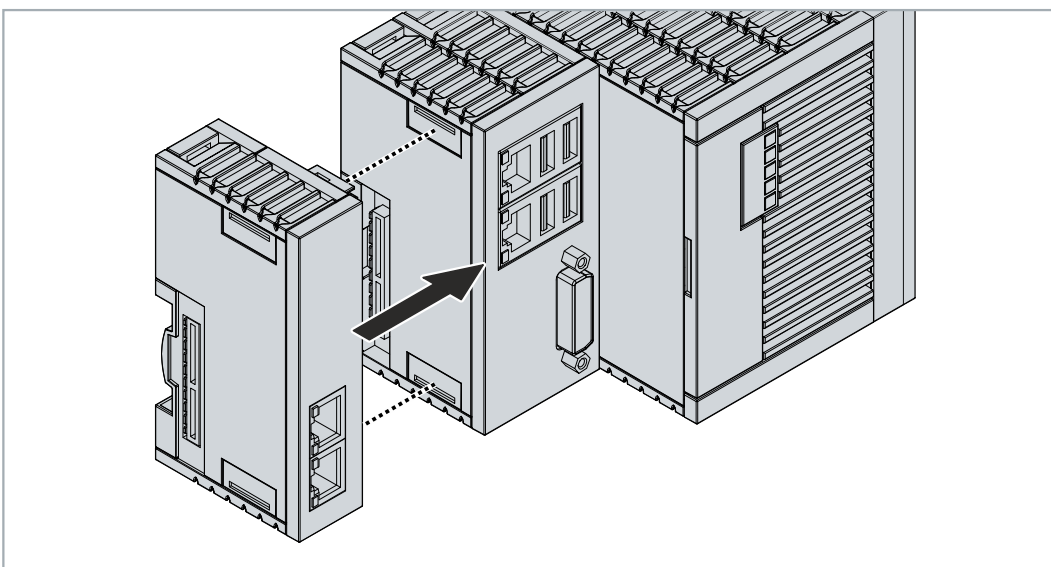

3. The module audibly clicks into place when the module is flush with the housing of the basic CPU module.
  - ⇒ Other modules are plugged in the same way if they are basic CPU modules of type CX20xx. The next step is to install the housing locking clips.

## 4.2 Installing the housing locking clips

The interlocking of the modules is usually strong enough. However, the controller and its modules may be exposed to shocks, vibrations or impacts. The modules can be securely connected to each other using locking clips.

### Proceed as follows:

1. Slide the locking clips between the cooling fins as shown in the illustration until the locking clips are flush with the housing.

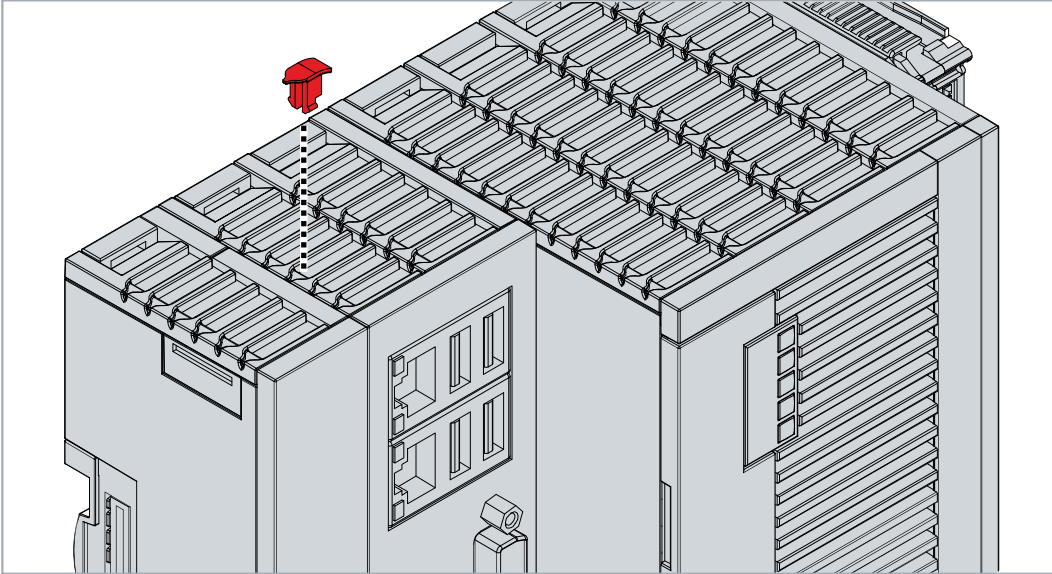

2. The locking clips are inserted on the top and bottom.

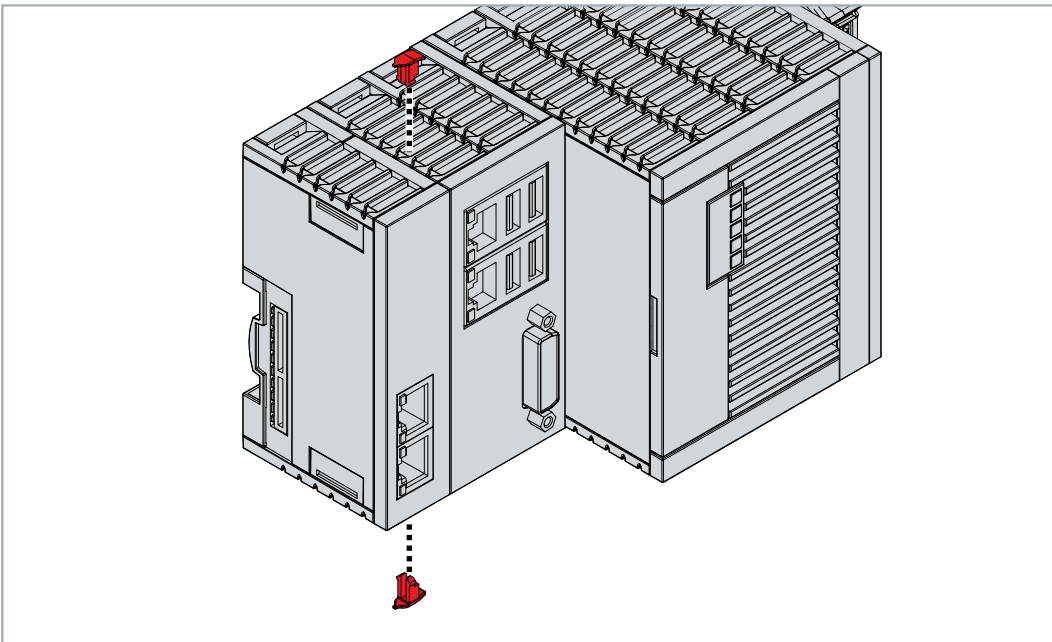

- ⇒ Once all extension modules are locked, the whole assembly can be installed on the DIN rail. To remove, the locking clips are lifted with a screwdriver and pulled out of the housing.

## 5 Error handling and diagnostics

### 5.1 LEDs on the Ethernet system interface

Display	LED	Meaning
	SPEED 1	Off: 10/100 Mbit/s mode Yellow: 1000 Mbit/s mode Green: 2500 Mbit/s mode
	LINK/ACT 1	OFF: no connection. Green: port is connected to a network. The LED flashes if data traffic takes place on the port.
	SPEED 2	Off: 10/100 Mbit/s mode Yellow: 1000 Mbit/s mode Green: 2500 Mbit/s mode
	LINK/ACT 2	OFF: no connection. Green: port is connected to a network. The LED flashes if data traffic takes place on the port.

### 5.2 Faults

Please also refer to the Safety instructions section.

#### Possible faults and their correction

Fault	Cause	Measures
no function after the embedded PC has been switched on	no power supply for the embedded PC, other causes	1. Check the fuse 2. Measure the supply voltage, check the connection, call Beckhoff support
Embedded PC does not boot fully	Hard disk damaged (e.g. due to switching off while software is running), incorrect setup, other causes	Check setup, call Beckhoff Support
Computer boots, software starts, but control does not operate correctly	Cause of the fault is either in the software or in parts of the plant outside the embedded PC	Call the manufacturer of the machine or the software.
Error during CFast card access	CFast card faulty, CFast slot faulty	Use a different CFast card to check the CFast slot, call Beckhoff Support
Embedded PC only works partially or temporarily	Defective components in the embedded PC	Call Beckhoff support

Please make a note of the following information **before** contacting Beckhoff service or support:

1. Precise device ID: CXxxxx-xxxx
2. Serial Number
3. Hardware version
4. any interfaces (N030, N031, B110, ...)
5. TwinCAT version used
6. Any components / software used

The quickest response will come from support / service in your country. Therefore please contact your regional contact. For details please refer to our website at <https://www.beckhoff.com> or ask your distribution partner.

## 6 Technical data

Technical data	CX2500-0062
Interfaces	2 x Ethernet
Chipset	Intel®-Ethernet-Controller I226
Data transfer rates	10/100/1000/2500 Mbit/s
Connection type	2 x RJ45
Power supply	via system bus (through CX2100-0xxx power supply modules)
Operating system	Windows 10 IoT Enterprise 2019 LTSC, 64-bit, Windows 10 IoT Enterprise 2021 LTSC, 64-bit
Max. power consumption	3 W
Dimensions (W x H x D)	24 mm x 99 mm x 54.5 mm
Weight	approx. 195 g
Relative humidity	95 % no condensation
Operating/storage temperature	-25° C ... +60 °C / -40 °C ... +85 °C
Vibration/shock resistance	conforms to EN 60068-2-6 / EN 60068-2-27
EMC immunity/emission	conforms to EN 61000-6-2/EN 61000-6-4
Protection rating	IP20



## 7 Appendix

### 7.1 Accessories

Table 3: Further spare parts.

Order number	Description
CX2900-0101	Housing locking clips (black) for CX52x0, CX56x0 and CX20xx. 10 locking sets of two clips each.
CX2900-0102	Cover for left-side bus connector, 5 pieces

## 7.2 Certifications

### **FCC Approvals for the United States of America**

#### **FCC: Federal Communications Commission Radio Frequency Interference Statement**

This equipment has been tested and found to comply with the limits for a Class A digital device, pursuant to Part 15 of the FCC Rules. These limits are designed to provide reasonable protection against harmful interference when the equipment is operated in a commercial environment. This equipment generates, uses, and can radiate radio frequency energy and, if not installed and used in accordance with the instruction manual, may cause harmful interference to radio communications. Operation of this equipment in a residential area is likely to cause harmful interference in which case the user will be required to correct the interference at his own expense.

### **FCC Approval for Canada**

#### **FCC: Canadian Notice**

This equipment does not exceed the Class A limits for radiated emissions as described in the Radio Interference Regulations of the Canadian Department of Communications.

## 7.3 Support and Service

Beckhoff and their partners around the world offer comprehensive support and service, making available fast and competent assistance with all questions related to Beckhoff products and system solutions.

### Download finder

Our [download finder](#) contains all the files that we offer you for downloading. You will find application reports, technical documentation, technical drawings, configuration files and much more.

The downloads are available in various formats.

### Beckhoff's branch offices and representatives

Please contact your Beckhoff branch office or representative for [local support and service](#) on Beckhoff products!

The addresses of Beckhoff's branch offices and representatives round the world can be found on our internet page: [www.beckhoff.com](http://www.beckhoff.com)

You will also find further documentation for Beckhoff components there.

### Beckhoff Support

Support offers you comprehensive technical assistance, helping you not only with the application of individual Beckhoff products, but also with other, wide-ranging services:

- support
- design, programming and commissioning of complex automation systems
- and extensive training program for Beckhoff system components

Hotline: +49 5246 963-157  
e-mail: [support@beckhoff.com](mailto:support@beckhoff.com)

### Beckhoff Service

The Beckhoff Service Center supports you in all matters of after-sales service:

- on-site service
- repair service
- spare parts service
- hotline service

Hotline: +49 5246 963-460  
e-mail: [service@beckhoff.com](mailto:service@beckhoff.com)

### Beckhoff Headquarters

Beckhoff Automation GmbH & Co. KG

Huelshorstweg 20  
33415 Verl  
Germany

Phone: +49 5246 963-0  
e-mail: [info@beckhoff.com](mailto:info@beckhoff.com)  
web: [www.beckhoff.com](http://www.beckhoff.com)

## List of tables

Table 1	Legend for the structure.....	10
Table 2	Ethernet interface X620 and X621, pin assignment.....	11
Table 3	Further spare parts.....	17

## List of figures

Fig. 1	Structure of a CX2500-0062 extension module. ....	10
Fig. 2	Ethernet interface (X620, X621).....	11
Fig. 3	Designation of Ethernet interfaces in the Device Manager. ....	11
Fig. 4	CX2500-0062 extension module, dimensions.....	13



More Information:  
[www.beckhoff.com/CX2500-0062](http://www.beckhoff.com/CX2500-0062)

Beckhoff Automation GmbH & Co. KG  
Hülshorstweg 20  
33415 Verl  
Germany  
Phone: +49 5246 9630  
[info@beckhoff.com](mailto:info@beckhoff.com)  
[www.beckhoff.com](http://www.beckhoff.com)

