

# BECKHOFF New Automation Technology

Documentation | EN

## PS3011-4820-0000

Power Supply 48 VDC, 20 A, 1 phase





# Table of contents

<b>1 Overview</b> .....	<b>5</b>
<b>2 Foreword</b> .....	<b>6</b>
2.1 Notes on the documentation .....	6
2.2 Safety instructions .....	7
2.3 Terminology and abbreviations .....	8
<b>3 Technical data, mounting, wiring</b> .....	<b>9</b>
3.1 AC input .....	9
3.2 DC input .....	11
3.3 Input inrush current .....	12
3.4 Output .....	13
3.5 Hold-up time .....	15
3.6 DC-OK relay contact .....	16
3.7 Shutdown input .....	17
3.8 Output voltage control .....	17
3.9 Efficiency and losses .....	18
3.10 Life expectancy .....	19
3.11 Terminals and wiring .....	20
3.12 Functional wiring diagram .....	21
3.13 Front side and operating elements .....	22
3.14 EMC .....	24
3.15 Environment .....	25
3.16 Protective functions .....	26
3.17 Safety features .....	26
3.18 Dielectric strength .....	27
3.19 Declaration of conformity and approvals .....	28
3.20 Dimensions and weight .....	29
<b>4 Application notes</b> .....	<b>30</b>
4.1 Repeated pulse load .....	30
4.2 Peak current capability .....	32
4.3 External input protection .....	33
4.4 Operation on two phases .....	33
4.5 Output circuit breakers .....	34
4.6 Charging batteries .....	35
4.7 Series connection .....	35
4.8 Parallel use to increase power .....	36
4.9 Parallel use for redundancy .....	37
4.10 Inductive and capacitive loads .....	38
4.11 Back-feeding loads .....	39
4.12 Use in a tightly sealed enclosure .....	39
4.13 Installation positions .....	39
<b>5 Disposal</b> .....	<b>41</b>
<b>6 Appendix</b> .....	<b>42</b>
6.1 Accessories .....	42

---

6.1.1	Redundancy and buffer modules .....	42
6.1.2	Mounting accessories .....	42
6.2	Documentation issue status .....	44
6.3	Support and Service.....	45

# 1 Overview

## PS3011-4820-0000 | Power supply 48 V, 20 A, 1-phase



- AC 100 - 240 V wide-range input
- width only 125 mm, weight only 1.9 kg
- 95.0% full load and excellent part-load efficiencies
- 150% peak power, 1440 W for up to 4 s
- 55 A high peak current over 10 ms for triggering fuses
- Safe Hiccup overload mode
- Active Power Factor Correction PFC
- Negligible inrush current surge
- Full power between -25°C and +60°C
- Current-sharing function for parallel use
- Remote control Output voltage
- DC-OK relay contact
- Shut-down input

The PS3011-4820-0000 is a 1-phase 48 V power supply with an output current of 20 A and an output power of 960 W. On the input side, the device features a wide-range input, active harmonic correction (PFC) and inrush current limiting.

The output operates according to the UI characteristic curve and switches to the safe hiccup mode in case of overload/short-circuit. The PS3011-4820-0000 power supply has an extra power feature with a maximum output power of 150% over 4 seconds and is able to trigger fuses precisely with a short-term peak current. A DC-OK LED, an overload LED and a potential-free relay contact monitor the status of the output voltage. The output voltage can be switched off by means of the shutdown contact.

The power supply is part of the PS3000 family and has a width of 125 mm.

The power supply unit is DNV-approved and can be used in shipbuilding, for example.

### Overview of technical data <sup>\*)</sup>

Overview of technical data	PS3011-4820-0000
Output voltage	DC 48 V (nominal)
Setting range	48 - 54 V
Output current	20 - 17.8 A (continuous); 30 - 26.7 A (short-term up to 4 s)
Output power	960 W (continuous); 1440 W (short-term up to 4 s)
Output ripple	< 150 mVpp (20 Hz to 20 MHz)
Input voltage AC	AC 100 - 240 V -15%/+10%
Mains frequency	50 - 60 Hz ±6%
Input current AC	8.6 / 4.5 A at 120 / 230 Vac
Power factor	0.99 / 0.99 at 120 / 230 Vac
AC Inrush current	typ. 17 / 11 A peak at 120 / 230 Vac
Efficiency	93.9 / 95.0% at 120 / 230 Vac
Losses	62.4 / 50.5 W at 120 / 230 Vac
Operating temperature range	-25°C to +70°C
Derating	24 W / °C (+60°C to +70°C) between 85 - 90 Vac see chapter <a href="#">Environment</a> [▶ 25]
Bridging time	Typ. 27 / 27 ms at 120 / 230 Vac
Dimensions (W x H x D)	125x124x127 mm (without DIN rail)
Weight	1.9 kg
Approvals/markings	CE, UKCA cULus DNV EAC

<sup>\*)</sup> All values typical for 48 V, 20 A, 230 Vac, 25°C ambient temperature and after a warm-up time of five minutes, unless otherwise stated.

## 2 Foreword

### 2.1 Notes on the documentation

#### Copyright

© Beckhoff Automation GmbH & Co. KG, Germany.

The reproduction, distribution and utilization of this document as well as the communication of its contents to others without express authorization are prohibited.

Offenders will be held liable for the payment of damages. All rights reserved in the event of the grant of a patent, utility model or design.

#### Disclaimer

The documentation has been prepared with care. The products described are, however, constantly under development.

We reserve the right to revise and change the documentation at any time and without prior announcement.

No claims for the modification of products that have already been supplied may be made on the basis of the data, diagrams and descriptions in this documentation.

#### Trademarks

Beckhoff®, TwinCAT®, TwinCAT/BSD®, TC/BSD®, EtherCAT®, EtherCAT G®, EtherCAT G10®, EtherCAT P®, Safety over EtherCAT®, TwinSAFE®, XFC®, XTS® and XPlanar® are registered trademarks of and licensed by Beckhoff Automation GmbH. Other designations used in this publication may be trademarks whose use by third parties for their own purposes could violate the rights of the owners.

#### Patent Pending

The EtherCAT Technology is covered, including but not limited to the following patent applications and patents: EP1590927, EP1789857, EP1456722, EP2137893, DE102015105702 with corresponding applications or registrations in various other countries.

#### Intended audience

This description is only intended for the use of trained specialists in control and automation engineering who are familiar with the applicable national standards.

It is essential that the documentation and the following notes and explanations are followed when installing and commissioning these components.

The qualified personnel is obliged to always use the currently valid documentation.

The responsible staff must ensure that the application or use of the products described satisfy all the requirements for safety, including all the relevant laws, regulations, guidelines and standards.

## 2.2 Safety instructions

### Description of instructions

In this documentation the following instructions are used.  
These instructions must be read carefully and followed without fail!

#### **DANGER**

##### **Serious risk of injury!**

Failure to follow this safety instruction directly endangers the life and health of persons.

#### **WARNING**

##### **Risk of injury!**

Failure to follow this safety instruction endangers the life and health of persons.

#### **CAUTION**

##### **Personal injuries!**

Failure to follow this safety instruction can lead to injuries to persons.

#### **NOTICE**

##### **Damage to environment/equipment or data loss**

Failure to follow this instruction can lead to environmental damage, equipment damage or data loss.



#### **Tip or pointer**

This symbol indicates information that contributes to better understanding.

### Intended use

This device is designed for installation in a housing and is intended for general professional use, for example in industrial control systems or office, communication and measuring equipment.

Do not use this power supply in installations where a malfunction could cause serious injury or danger to human life.

### Exclusion of liability

All the components are supplied in particular hardware and software configurations appropriate for the application. Modifications to hardware or software configurations other than those described in the documentation are not permitted, and nullify the liability of Beckhoff Automation GmbH & Co. KG.

### Personnel qualification

This description is only intended for trained specialists in control, automation and drive engineering who are familiar with the applicable national standards.

### Safety regulations

Please note the following safety instructions and explanations!  
Product-specific safety instructions can be found on following pages or in the areas mounting, wiring, commissioning etc.

## Safety instructions and installation requirements for the PS3011-4820-0000 power supply

### DANGER



#### Danger of electric shock, fire, injuries, injuries resulting in death!

- Do not use the power supply without proper earthing (protective conductor). Use the terminal at the input terminal strip for the earth connection, not one of the screws on the housing.
- Switch off the power supply before working on the device. Provide protection against unintentional reconnection.
- Ensure proper wiring by following all local and national regulations.
- Do not modify or attempt to repair the device.
- Do not open the device, as high voltages are present inside.
- Avoid foreign bodies entering the housing.
- Do not use the device in damp locations or in areas where moisture or condensation is likely to occur.
- Do not touch the device when it is switched on or immediately after it has been switched off. Hot surfaces can cause burns.

#### Further notes on installation requirements

- This device contains no serviceable parts.
- Triggering of an internal fuse indicates an internal defect.
- In the event of damage or malfunction during installation or operation, switch off the device immediately and return it to the factory for inspection.
- Mount the device on a DIN rail so that the input and output terminals are at the bottom of the device. For other mounting orientations, please refer to the derating requirements in chapter [Mounting positions](#) [▶ 39].
- This device is designed for convection cooling and does not require an external fan. Do not obstruct the air flow and do not cover the ventilation grille (e.g., cable ducts) by more than 15%!
- Maintain the following installation distances: 40 mm at the top, 20 mm at the bottom and 5 mm on the left and right are recommended if the device continuously runs at more than 50% of the rated output. Increase this distance to 15 mm if the adjacent device is a heat source (e.g., another power supply).

## 2.3 Terminology and abbreviations

<b>PE and the earthing symbol</b> 	PE is the abbreviation for "protective earth" and has the same meaning as the earthing symbol 
<b>Earth, ground</b>	This document uses the term "earth" which is the same as the U.S. term "ground".
<b>T.b.d.</b>	Still to be defined, value or description will follow in due course.
<b>AC 230 V</b>	A value preceded by "AC" or "DC" represents a nominal voltage or a nominal voltage range. The nominal voltage or the nominal voltage range may be provided with tolerances. (usually V ±15%). The calculated total range then indicates the working range of the device. Example: DC 12 V refers to a 12 V battery, regardless of whether it is fully charged (13.7 Vdc) or discharged (10 Vdc).
<b>230 Vac</b>	A value followed by the unit Vac or Vdc is an instantaneous value that does not contain any additional tolerances.
<b>50 Hz vs. 60 Hz</b>	Unless otherwise specified, AC 230 V parameters are valid at a mains frequency of 50 Hz.
<b>may</b>	A keyword indicating a choice without implied preference.
<b>shall</b>	A keyword indicating a mandatory requirement.
<b>should</b>	A keyword indicating a choice with a clearly preferred method of implementation.



### 3 Technical data, mounting, wiring

#### 3.1 AC input

AC input			
AC input	Nom.	AC 100 - 240 V	Suitable for TN, TT and IT networks
AC input range	Min.	90 - 264 Vac	Continuous operation
	Min.	85 - 90 Vac	< 55°C continuous ambient temperature permissible > 55°C ambient temperature for a short time or with reduction of the output power according to Fig. <i>Output current over ambient temperature</i> (in chapter <a href="#">Environment</a> [▶ 25])
	Min.	60 - 85 Vac	Full power for 200 ms, no damage between 0 and 85 Vac
	Min.	264 - 300 Vac	< 500 ms
Permissible voltage L or N to earth	Max.	300 Vac	Continuous according to IEC 62103
Input frequency	Nom.	50 - 60 Hz	±6%
Turn-on voltage	typically	80 Vac	Static, load independent, see Fig. <i>Input voltage range; Turn-on behavior definitions</i>
Shut-down voltage	typically	74 Vac	Static, load independent, see Fig. <i>Input voltage range; Turn-on behavior definitions</i>
External input protection	see recommendations in chapter <a href="#">External input protection</a> [▶ 33]		

AC input		AC 100 V	AC 120 V	AC 230 V	
Input current	typically	10.5 A	8.6 A	4.5 A	At 48 V, 20 A, see Fig. <i>Input current over output current; power factor over output current</i>
Power factor <sup>1)</sup>	typically	0.99	0.99	0.99	At 48 V, 20 A, see Fig. <i>Input current over output current; power factor over output current</i>
Peak factor <sup>2)</sup>	typically	1.47	1.53	1.56	At 48 V, 20 A
Start-up delay	typically	800 ms	750 ms	700 ms	See Fig. <i>Input voltage range; Turn-on behavior definitions</i>
Rise time	typically	16 ms	16 ms	16 ms	At 48 V, 20 A, 0 mF load capacity, see Fig. <i>Input voltage range; Turn-on behavior definitions</i>
	typically	55 ms	55 ms	55 ms	At 48 V, 20 A, 20 mF load capacity, see Fig. <i>Input voltage range; Turn-on behavior definitions</i>
Turn-on overshoot	Max.	100 mV	100 mV	100 mV	See Fig. <i>Input voltage range; Turn-on behavior definitions</i>

1) The power factor is the ratio of real (or active) power to apparent power in an AC circuit.

2) The peak factor is the mathematical ratio of the peak value to the RMS value of the input current waveform.

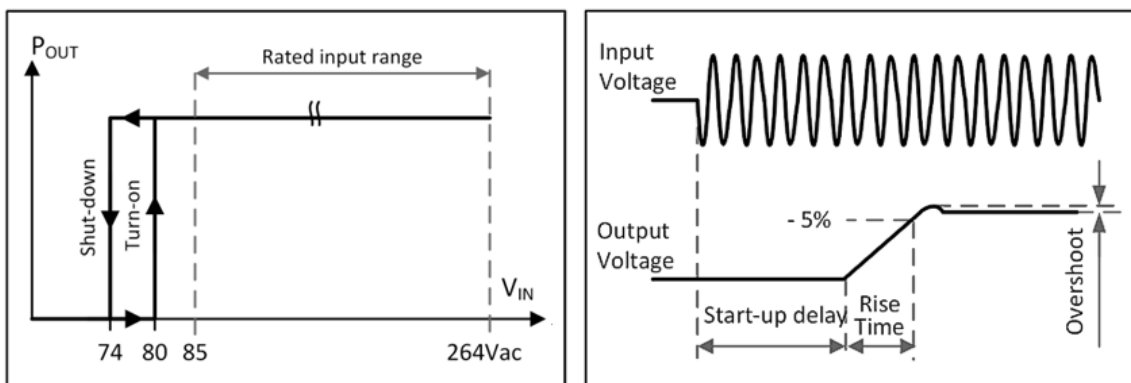

Fig. 1: Input voltage range; Turn-on behavior definitions

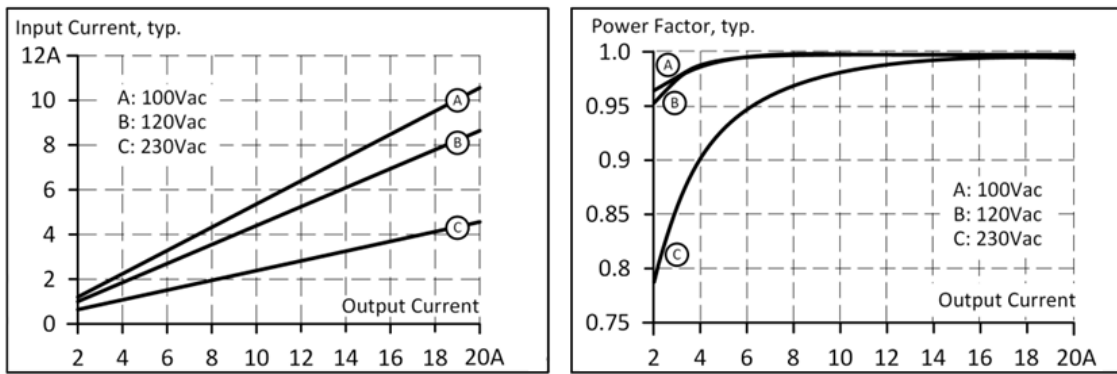

Fig. 2: Input current over output current; power factor over output current

## 3.2 DC input

Do not use the power supply unit with DC input voltages!

### 3.3 Input inrush current

Active inrush current limitation limits the inrush current surge to a negligible value after the input voltage is switched on. The input inrush current is usually lower than the continuous input current.

		AC 100 V	AC 120 V	AC 230 V	
Input inrush current <sup>*)</sup>	Max.	25 A <sub>peak</sub>	22 A <sub>peak</sub>	16 A <sub>peak</sub>	over the entire temperature range; Mains interruptions > 1 s
	typically	20 A <sub>peak</sub>	17 A <sub>peak</sub>	11 A <sub>peak</sub>	over the entire temperature range; Mains interruptions > 1 s
Turn-on energy	Max.	5 A <sup>2</sup> s	5 A <sup>2</sup> s	5 A <sup>2</sup> s	over the entire temperature range; Mains interruptions > 1 s

<sup>\*)</sup> The charge current of the interference suppression capacitors during the first few microseconds after switching on is not taken into account.

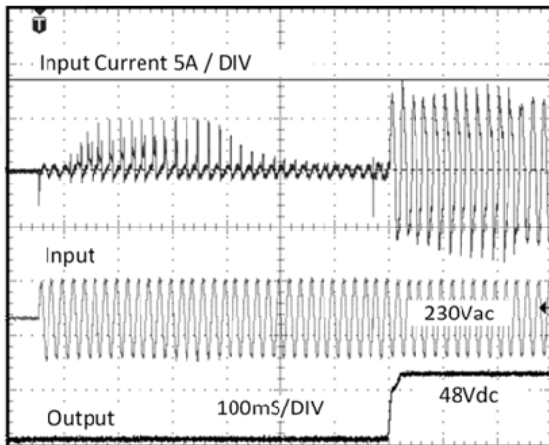

Fig. 3: Typical Turn-on behavior at nominal load, 230 Vac input voltage and 25°C ambient temperature

### 3.4 Output

Output			
Output voltage	Nom.	DC 48 V	
Adjustment range	Min.	48 - 54 Vdc	Guaranteed value
	Max.	56 Vdc	This is the maximum output voltage that can occur in the end position of the potentiometer in clockwise direction due to tolerances. It is not a guaranteed value that can be achieved. A typical value is 55 V.
Factory settings	typically	48.0 Vdc	±0.2%, at full load (cold device), in "Single Use" mode
	typically	46.0 Vdc	±0.5%, at full load (cold device), in "Parallel Use" mode
	typically	48.0 Vdc	At idle, cold unit, in "Parallel Use" mode
Line regulation	Max.	10 mV	Between 85 and 300 Vac
Load regulation	Max.	50 mV	In "Single Use" mode: between 0 and 20 A, static value, see Fig. <i>Output voltage over output current typ. in "Single Use" mode</i> ,
	typically	2000 mV	In "Parallel Use" mode: between 0 and 20 A, static value, see Fig. <i>Output voltage over output current typ. in "Parallel Use" mode</i> ,
Residual ripple and ripple voltage	Max.	150 mV <sub>pp</sub>	Bandwidth 20 Hz to 20 MHz, 50 Ohm
Output current - continuous	Nom.	20 A	At 48 V, see Fig. <i>Output voltage over output current typ. in "Single Use" mode; output voltage over output current typ. in "Parallel Use" mode</i>
	Nom.	17.8 A	At 54 V, see Fig. <i>Output voltage over output current typ. in "Single Use" mode; output voltage over output current typ. in "Parallel Use" mode</i>
Output current - Extra power up to 4 s <sup>1)</sup>	Nom.	30 A	At 48 V, see Fig. <i>Output voltage over output current typ. in "Single Use" mode; output voltage over output current typ. in "Parallel Use" mode</i>
	Nom.	26.7 A	At 54 V, see Fig. <i>Output voltage over output current typ. in "Single Use" mode; output voltage over output current typ. in "Parallel Use" mode</i>
	typically	55 A	up to 10 ms, output voltage remains above 40 V, see Fig. <i>Short circuit at output, Hiccup mode, typ.; Dynamic overcurrent capacity, typ.</i> This peak current is available once per second. for further peak current measurements see chapter <a href="#">Peak current capability</a> [▶ 32]
Output power - continuous	Nom.	960 W	At 48 - 54 V
Output power - Extra Power 4 s <sup>1)</sup>	Nom.	1440 W	At 48 - 54 V
Extra power time (bonus time)	typically	4 s	Time until the output voltage drops, see Fig. <i>Bonus time over output power</i>
Recovery time	typically	7 s	Overload-free time until the power manager is reset, see Fig. <i>Extra power recovery time</i>
Overload characteristics		Continuous current	Output voltage > 40 Vdc, see Fig. <i>Output voltage over output current</i>
		Hiccup mode <sup>2)</sup>	Output voltage < 40 Vdc, see Fig. <i>Output voltage over output current</i>
Short circuit current	Min.	30 A <sup>3)</sup>	Load impedance 50 mOhm, see Fig. <i>Short-circuit at output, Hiccup mode, typ.; Dynamic overcurrent capacity, typ.</i>
	Max.	35 A <sup>3)</sup>	Load impedance 50 mOhm, see Fig. <i>Short-circuit at output, Hiccup mode, typ.; Dynamic overcurrent capacity, typ.</i>
	Max.	11.5 A	RMS value of current, load impedance 50 mOhm, see Fig. <i>Output short circuit, Hiccup mode, typ.; Dynamic overcurrent capacity, typ.</i>
	typically	62 A	Up to 10 ms load impedance < 10 mOhm, see Fig. <i>Output short circuit, Hiccup mode, typ.; Dynamic overcurrent capacity, typ.</i>
Output capacity	typically	3700 µF	Included in the power supply

**1) Extra power**

The power supply is designed to support loads with higher short-term power requirements without damage or shutdown.

The short-time duration/bonus time is controlled in hardware by an output power manager.

Extra power is available repeatedly. Detailed information can be found in the chapter on [Repeated pulse load](#) [▶ 30].

If the power supply is subjected to extra power for longer than shown in the bonus time diagram (see Fig. [Bonus time over output power](#) [▶ 14]), the maximum output power is automatically reduced to 960 W.

If the power demand is continuously above 960 W and the voltage drops below approx. 40 V (due to the current control mode in case of overload), the device switches off and periodically makes restart attempts. This behavior is referred to as Hiccup mode (see description below).

If the voltage is above 40 V, the device supplies current continuously.

2) **Hiccup mode**

In the event of a severe overload, the power supply provides continuous output current for 4 s. The output is then switched off for about 17 seconds before a new switch-on attempt is automatically made. This cycle is repeated as long as the overload persists. If the overload persists, the output current is restored for 2 to 4 seconds (depending on the overload), followed by another recovery time of 17 seconds. After the overload has been rectified, the device will operate normally. See Fig. *Short circuit at output, Hiccup mode, typ.* During the pause time, a small residual voltage and a residual current are applied to the output.

3) The discharge current of the output capacitors is not included.

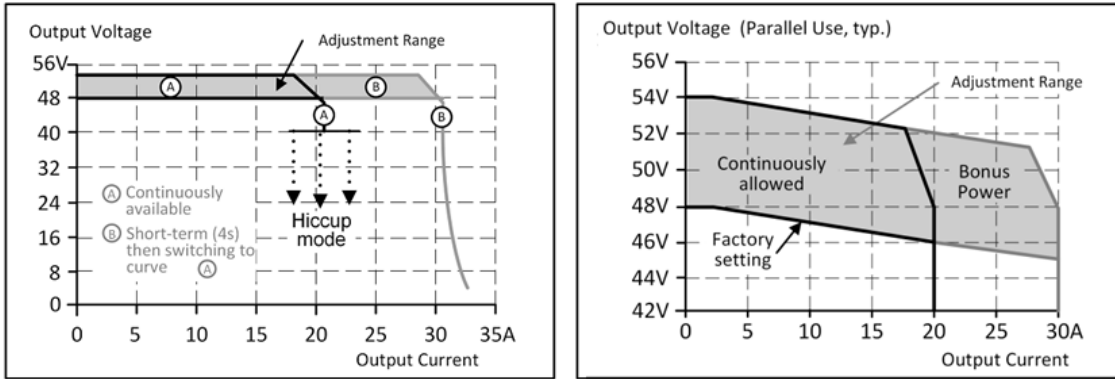

Fig. 4: Output voltage over output current typ. in "Single Use" mode; output voltage over output current typ. in "Parallel Use" mode,

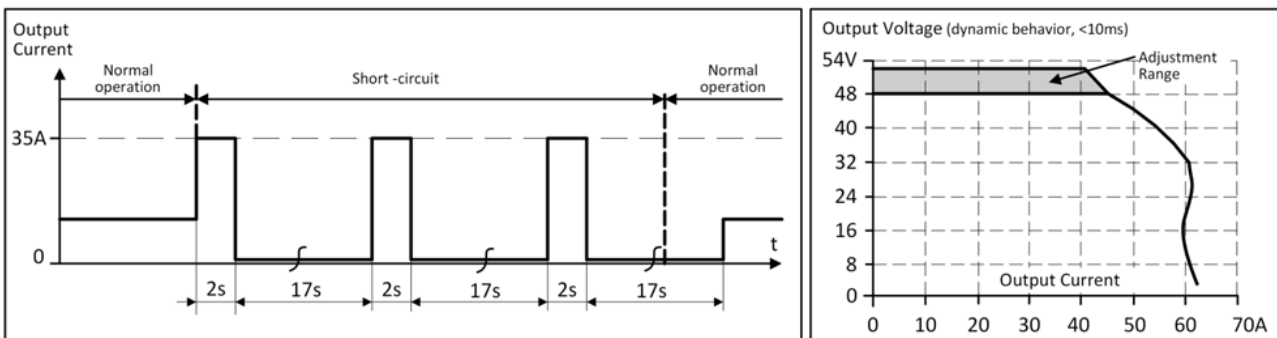

Fig. 5: Short circuit at output, Hiccup mode, typ.; Dynamic overcurrent capacity, typ.

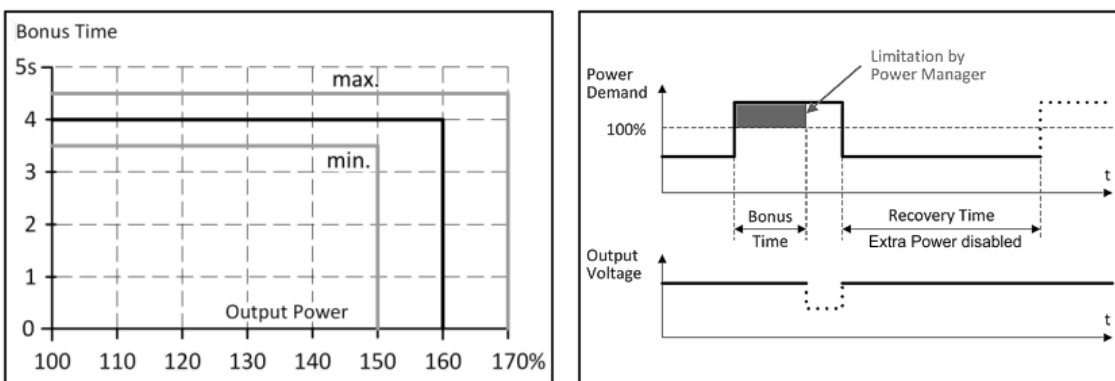

Fig. 6: Bonus time over output power; Extra power recovery time

Extra power is available as soon as the power is turned on and after an output short-circuit or output overload.

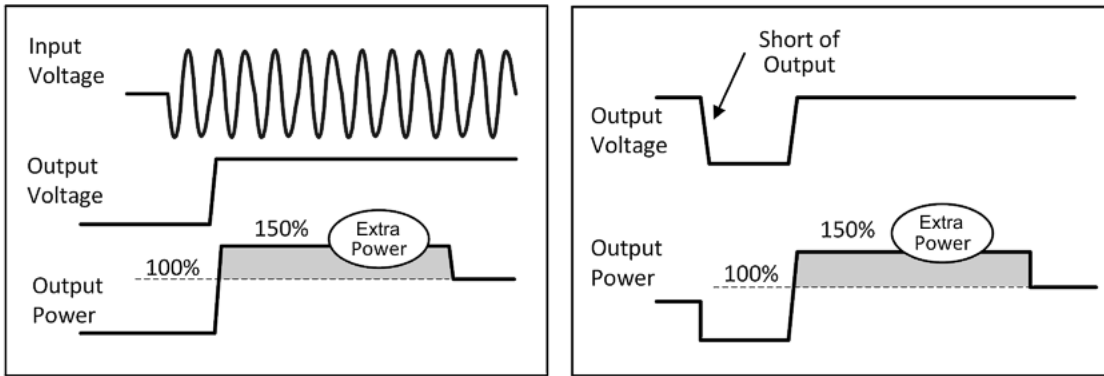

Fig. 7: Extra power after switching on; extra power after short circuit or overload

### 3.5 Hold-up time

The hold-up time is the time during which the output voltage of a power supply unit remains within the specification after a loss of input power. The hold-up time depends on the output load. Without load the hold-up time can be several seconds. The green DC-OK LED also lights up during this time.

		AC 100 V	AC 120 V	AC 230 V	
Hold-up time	typically	54 ms	54 ms	54 ms	At 48 V, 10 A, see Fig. <i>Hold-up time over input voltage</i>
	min.	45 ms	45 ms	45 ms	At 48 V, 10 A, see Fig. <i>Hold-up time over input voltage</i>
	typically	27 ms	27 ms	27 ms	At 48 V, 20 A, see Fig. <i>Hold-up time over input voltage</i>
	min.	23 ms	23 ms	23 ms	At 48 V, 20 A, see Fig. <i>Hold-up time over input voltage</i>

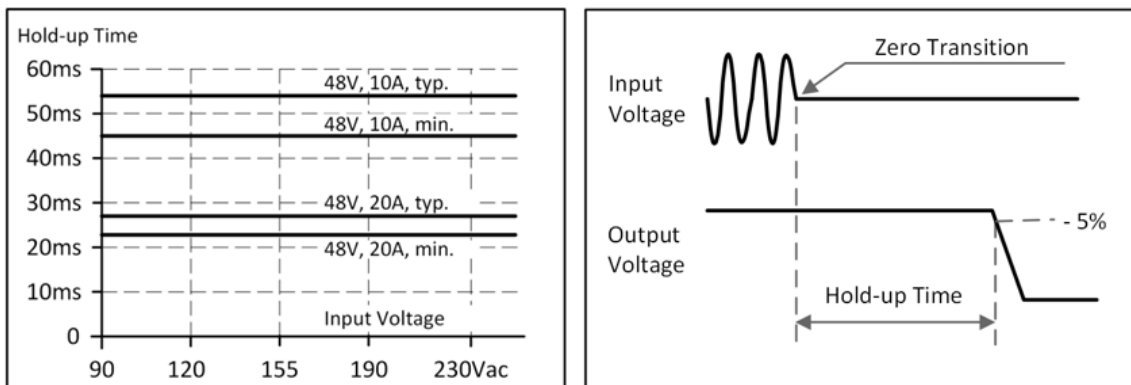

Fig. 8: Hold-up time over input voltage; switch-off behavior, definitions

### 3.6 DC-OK relay contact

This function monitors the output voltage generated by the power supply itself. It is independent of a voltage fed back from a unit connected in parallel to the power supply output.

The contact closes	when the output voltage reaches 90% of the set output voltage.
The contact opens	when the output voltage drops more than 10% below the set output voltage. Short bursts are extended to a signal length of 250 ms. Drops that are shorter than 1 ms are ignored.
The contact closes again	when the output voltage exceeds 90% of the set voltage.
Contact load capacity	Maximum 60 Vdc 0.3 A, 30 Vdc 1 A, 30 Vac 0.5 A, ohmic load Minimum permissible load: 1 mA at 5 Vdc
Insulation voltage	See the table in chapter <a href="#">Dielectric strength</a> [▶ 27]

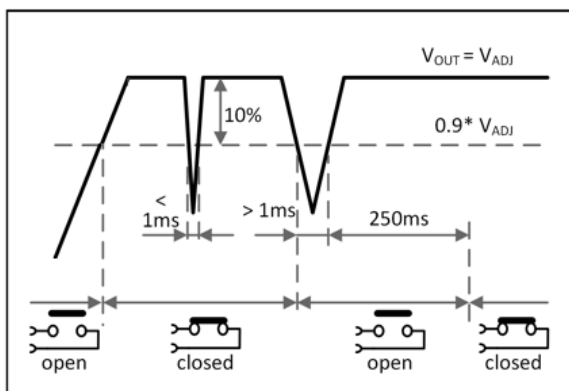

Fig. 9: Behavior of the DC-OK relay contact

**● DC-OK function**

**i** The DC-OK function requires the output voltage to reach the rated (=set) level after power-up in order to function as specified.

- If this level is not reached, the overload LED lights up and the DC-OK contact opens. The overload LED goes out when the set voltage is reached.
- ⇒ This is an important condition to be considered especially if the load is a battery, the power supply is used in parallel or the power supply is used for N+1 redundant systems.



### 3.7 Shutdown input

The shutdown input allows the output of the power supply to be switched off by means of a signal switch or external voltage.

- The shutdown takes place without delay, while switching on is delayed by up to 350 ms.
- When switched off, the output voltage is less than 4 V and the output power is less than 0.5 W.
- When units are connected in parallel, the voltage difference between the various negative output terminals must be less than 1 V.
- When operating several power supplies in series, only wiring option "A" with single signal switches is permitted.

**i** **Information regarding the use of the shutdown input**

Please note the following:

- Option C (see diagram below) requires current reduction capability of the voltage source. Do not use a blocking diode!
- The shutdown function does not include any safety functionality

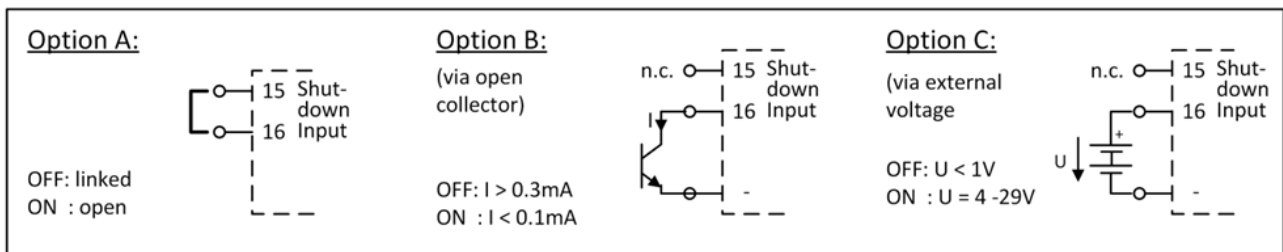

Fig. 10: Activation of the shutdown input

### 3.8 Output voltage control

The shutdown input can also be used to remotely adjust the output voltage between typically 44 Vdc and 54 Vdc. All other functions of the shutdown input remain the same.

The control voltage is relative to the ground of the 48 V output terminal (negative output voltage).

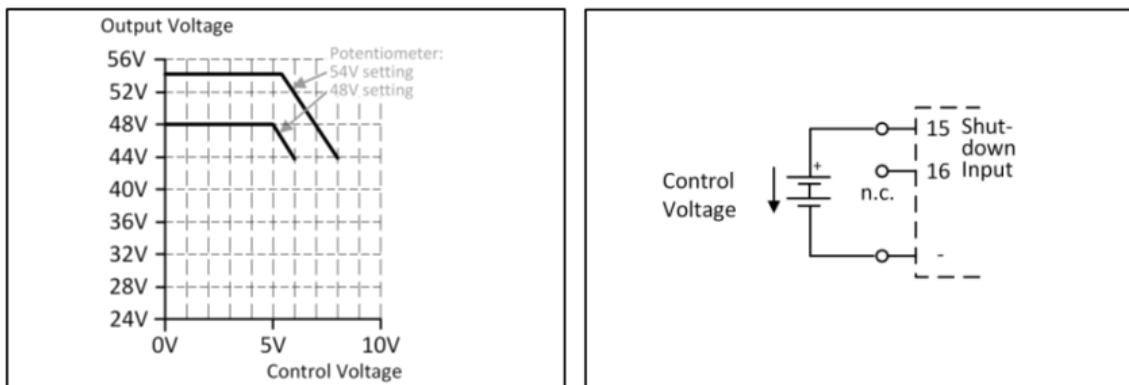

Fig. 11: Remote control of the output voltage; applying the control voltage

**Instructions:**

1. Set the unit to "Single Use" mode.
2. Set the output voltage (48 - 54 V) to the maximum required voltage.
3. Apply a control voltage to reduce the output voltage.

### 3.9 Efficiency and losses

		AC 100 V	AC 120 V	AC 230 V	
Efficiency	typically	93.5%	93.9%	95.0%	At 48 V, 20 A
Average efficiency <sup>*)</sup>	typically	92.9%	93.3%	93.9%	25% at 5 A, 25% at 10 A, 25% at 15 A, 25% at 20 A
Losses	typically	3.60 W	3.5 W	3.3 W	With activated shutdown
	typically	13.5 W	12.8 W	12.8 W	At 48 V, 0 A (no load)
	typically	35.6 W	34.0 W	30.1 W	At 48 V, 10 A (half load)
	typically	66.7 W	62.4 W	50.5 W	At 48 V, 20 A (nominal load)

<sup>\*)</sup> The average efficiency is based on assumptions for a typical application with a power supply load of:  
 25% of the nominal load for 25% of the time,  
 50% of the nominal load for 25% of the time,  
 75% of the nominal load for 25% of the time and  
 100% of the nominal load during the remaining time.

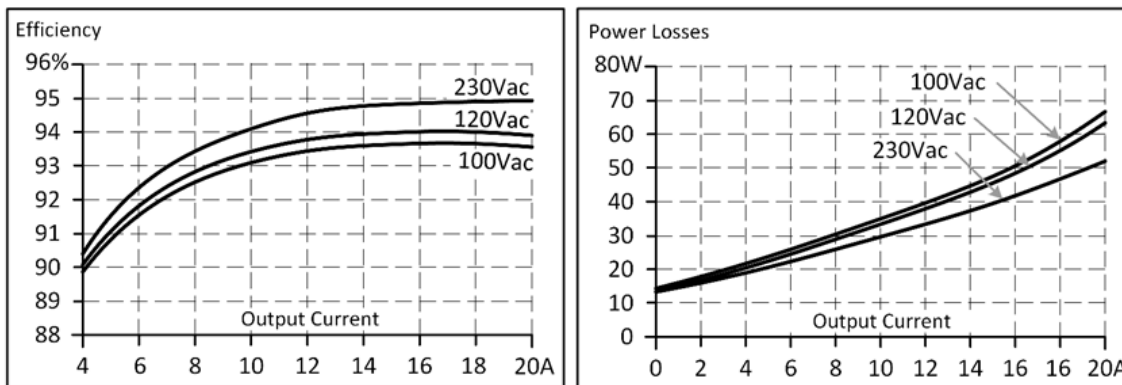

Fig. 12: Efficiency over output current; losses over output current

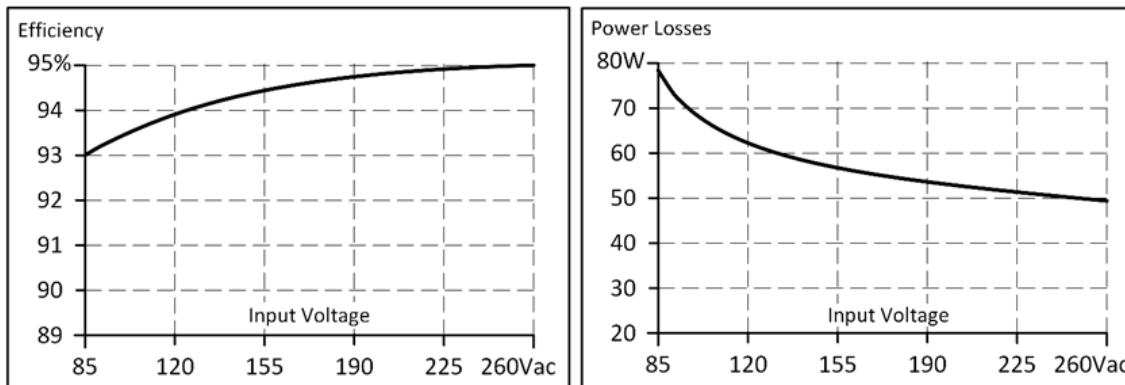

Fig. 13: Efficiency over input voltage; losses over input voltage

### 3.10 Life expectancy

	AC 100 V	AC 120 V	AC 230 V	
Calculated life expectancy <sup>1)</sup>	299,000 h <sup>1)</sup>	305,000 h <sup>1)</sup>	327,000 h <sup>1)</sup>	At 48 V, 10 A and +25°C
	106,000 h	108,000 h	116,000 h	At 48 V, 10 A and +40°C
	180,000 h <sup>1)</sup>	193,000 h <sup>1)</sup>	253,000 h <sup>1)</sup>	At 48 V, 20 A and +25°C
	64,000 h	68,000 h	90,000 h	At 48 V, 20 A and +40°C
MTBF <sup>2)</sup> SN 29500, IEC 61709	491,000 h	481,000 h	537,000 h	At 48 V, 20 A and +25°C
	274,000 h	269,000 h	300,000 h	At 48 V, 20 A and +40°C
MTBF <sup>2)</sup> MIL HDBK 217F Ground Benign	170,000 h	171,000 h	183,000 h	At 48 V, 20 A and +25°C; Ground Benign GB25
	126,000 h	127,000 h	137,000 h	At 48 V, 20 A and +40°C; Ground Benign GB40
MTBF <sup>2)</sup> MIL HDBK 217F Ground Fixed	36,000 h	36,000 h	39,000 h	At 48 V, 20 A and +25°C; Ground Fixed GB25
	27,000 h	27,000 h	30,000 h	At 48V, 20A and +40°C; Ground Fixed GF40

<sup>1)</sup> The **calculated life expectancy** shown in the table indicates the minimum number of operating hours (service life) and is determined by the life expectancy of the built-in electrolytic capacitors. The life expectancy is stated in operating hours and is calculated according to the specifications of the capacitor manufacturer. The manufacturer of the electrolytic capacitors only guarantees a maximum life of up to 15 years (131,400 h). Any number exceeding this value represents a calculated theoretical lifetime which can be used to compare devices.

<sup>2)</sup> **MTBF** stands for **Mean Time Between Failure**, which is calculated on the basis of statistical equipment failures and indicates the reliability of a device. It is the statistical representation of the probability of failure of a device and does not necessarily represent the service life of a product. The MTBF number is a statistical representation of the probability of equipment failure. For example, an MTBF number of 1,000,000 h means that statistically, if 10,000 devices are installed in the field, one device will fail every 100 hours. However, it is not possible to determine whether the failed device has run for 50,000 hours or only 100 hours.

### 3.11 Terminals and wiring

The terminals are designed to be finger-safe according to IP20 and are suitable for field or factory wiring.

Technical data	Input	Output	DC-OK signal
Connection cross-section	e*: 0.5 - 6 mm <sup>2</sup> f*: 0.5 - 4 mm <sup>2</sup> a*: max. 4 mm <sup>2</sup> (d<2.8 mm)	e*: 0.5 - 16 mm <sup>2</sup> f*: 0.5 - 10 mm <sup>2</sup> a*: max. 10 mm <sup>2</sup> (d<5.2 mm)	e*: 0.15 - 1.5 mm <sup>2</sup> f*: 0.15 - 1.5 mm <sup>2</sup> a*: max. 1.5 mm <sup>2</sup> (d<1.5 mm)
Connection cross-section (AWG)	e*: AWG 20-10 f*: AWG 20-10 a*: AWG 20-10 (d<2.8 mm)	e*: AWG 22-8 f*: AWG 22-8 a*: AWG 22-8 (d<5.2 mm)	e*: AWG 26-14 f*: AWG 26-14 a*: AWG 26-14 (d<1.5 mm)
Strip length	7 mm / 0.28 inch	12 mm / 0.5 inch	7 mm / 0.28 inch
Screwdriver	3.5 mm Slotted screwdriver or Phillips screwdriver No. 2	3.5 mm or 5 mm Slotted screwdriver or Phillips screwdriver No. 2	3.0 mm Slotted screwdriver (to open the spring)
Recommended tightening torque	1 Nm, 9 lb.in	2.3 Nm, 20.5 lb.in	Not applicable

e\* = solid wire  
f\* = stranded wire  
a\* = with ferrule

#### Wiring instructions:

- Use suitable copper cables that are designed for at least the following operating temperatures:  
+60°C for ambient temperatures up to +45°C and  
+75°C for ambient temperatures up to +60°C and  
+90°C for ambient temperatures up to +70°C.
- Observe the national installation rules and regulations!
- Make sure that all single wires of a strand are connected to the terminal!
- Do not use the device without PE connection.
- Unused terminals should be tightened firmly.
- Ferrules are permitted.

#### Series connection of power supply units:

Series connection (looping from one power supply output to the next) is permitted as long as the average output current flowing through a connection pin does not exceed 54 A. For higher currents please use a separate distribution terminal strip as shown in Fig. *Using distribution terminals*.

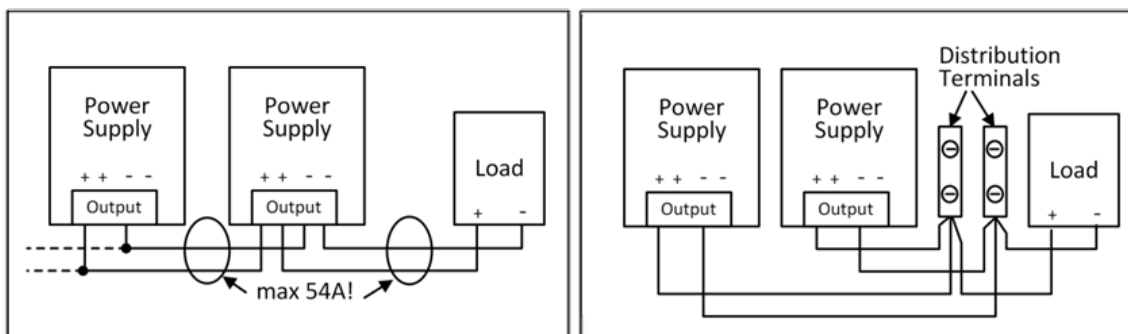

Fig. 14: Series connection of outputs; use of distribution terminals

### 3.12 Functional wiring diagram

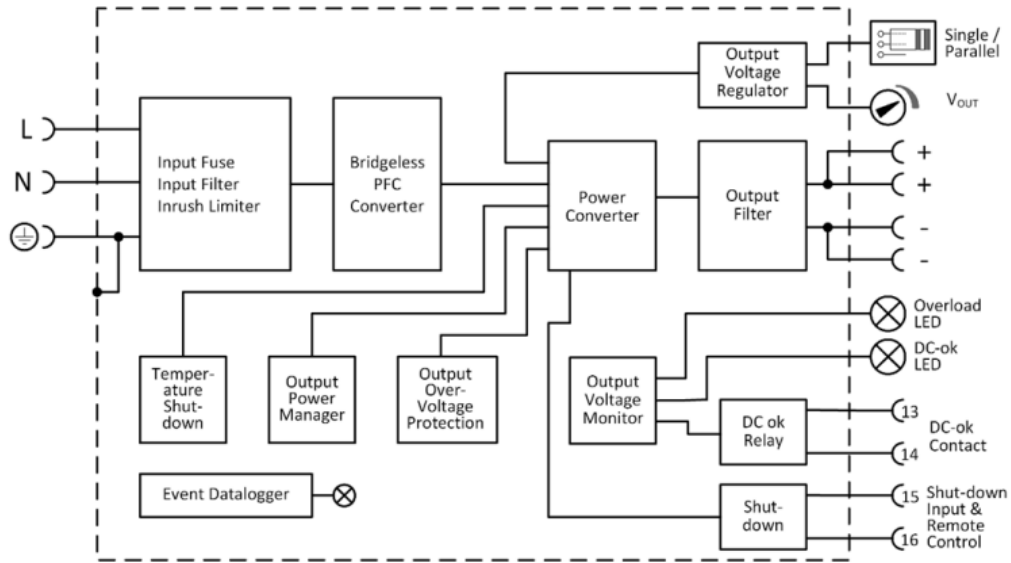

Fig. 15: Functional wiring diagram

### 3.13 Front side and operating elements

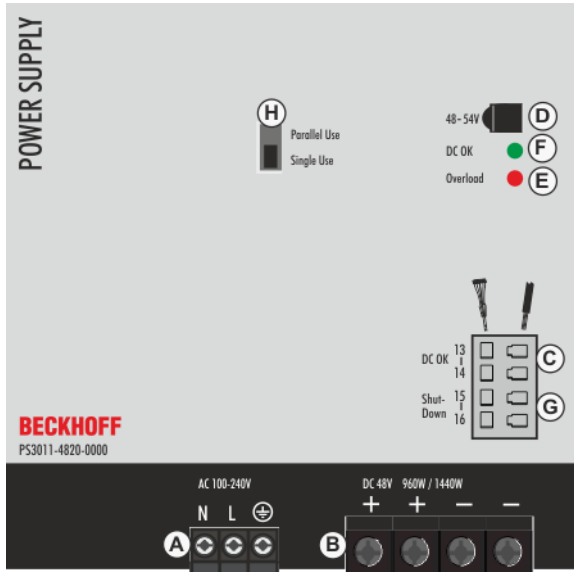



Fig. 16: Front PS3011-4820-0000

#### Input terminals (screw terminals)

Designation (A)	Description
N	Mains input N
L	Mains input L
	PE input (protective conductor)

#### Output terminals (screw terminals, two contact pins per pole)

Designation (B)	Description
+	two identical positive poles, positive output
-	two identical negative poles, negative output

#### DC-OK relay contact (spring-loaded terminals)

Designation (C)	Description
13 / 14 make contact	The DC-OK relay contact is synchronized with the DC-OK LED See chapter on <a href="#">DC OK relay contact</a> [▶ 16] for more information.

#### Potentiometer for the output voltage

Designation (D)	Description
Potentiometer cover	Open the flap to adjust the output voltage. Factory setting: 48.0 V

#### Overload LED

Designation (E)	Description
LED red	On when the voltage at the output terminals is <90% of the set output voltage, or in the event of a short circuit in the output. Flashing, when the shut-down has been activated or the unit has switched off due to over-temperature. The input voltage is always required.

#### DC OK LED

Designation (F)	Description
LED green	On when the voltage at the output terminals is >90% of the set output voltage.

**Shutdown input**

Designation (G)	Description
Shutdown input	Input for shutdown and remote control Enables the power supply to be switched off. Can be activated by a switch contact or external voltage. The remote control input allows the output voltage to be set between 44 V and 54 V. For details see chapters <a href="#">DC-OK relay contact [►_16]</a> and <a href="#">Shutdown input [►_17]</a>

**Selector switch for "Parallel Use" / "Single Use" mode**

Designation (H)	Description
Selector switch for "Parallel Use" / "Single Use" mode	Set the jumper to "Parallel Use" mode if power supplies are connected in parallel to increase the output power. In order to distribute the load current between the individual power supplies, "Parallel Use" mode regulates the output voltage so that the idle voltage is approx. 4% higher than at nominal load. See also chapter <a href="#">Parallel Use for power increase [►_36]</a> . A missing jumper corresponds to "Single Use" mode.

LED displays	Overload LED	DC-OK LED	DC-OK contact
Normal mode	OFF	ON	Closed
During extra power	OFF	ON	Closed
Overload ( <a href="#">Hiccup mode [►_14]</a> )	flashes	OFF	Open
Short circuit at output	flashes	OFF	Open
Temperature switch-off	flashes	OFF	Open
Shutdown input active	flashes	OFF	Open
No input power	OFF	OFF	Open

### 3.14 EMC

The power supply is suitable without any restrictions for application in industrial environments as well as in residential, commercial and light industrial areas and small businesses.

The device was tested according to EN 61000-6-1, EN 61000-6-2, EN 61000-6-3 and EN 61000-6-4.

EMC interference immunity			
Strong transients	VDE 0160	Over the entire load range	750 V, 1.3 ms

EMC interference emission	According to the generic standards: EN 6100-6-3 and EN 6100-6-4		
Conducted interference emission, input lines	EN 55011, EN 55022, FCC Part 15, CISPR 11, CISPR 22	Class B	
Conducted interference emission, output lines	IEC/CISPR 16-1-2, IEC/CISPR 16-2-1,	10 dB higher than the AV limit value curve for the DC power connection according to EN 61000-6-3 <sup>1)</sup>	
Interfering radiation	EN 55011, EN 55022	Class B	
Harmonic input current	EN 61000-3-2	Requirements for Class A devices met	
Voltage fluctuations, flicker	EN 61000-3-3	Requirements met <sup>2)</sup>	

This device complies with FCC Part 15.  
 Operation is subject to the following two conditions:

- This device must not cause adverse interference, and
- This device must tolerate any interference it is subjected to, including interference that may cause undesired operation.

<sup>1)</sup> Restrictions apply to residential, commercial and light industrial applications as well as to small businesses involving local DC networks according to EN 61000-6-3. No restrictions for all types of industrial applications

<sup>2)</sup> Tested with constant current loads, non-pulsating



### 3.15 Environment

Environment		
Operating temperature <sup>1)</sup>	-25°C to +70°C	Reduction of the output power according to Fig. <i>Output current over ambient temperature</i>
Storage temperature	-40°C to +85°C	For storage and transport
Output load reduction (derating)	24 W/°C	+60°C to +70°C
Humidity <sup>2)</sup>	5 to 95% r.h.	According to IEC 60068-2-30
Oscillation, sinusoidal	2-17.8 Hz: ±1.6 mm; 17.8-500 Hz: 1 g 2 hours/axis	According to IEC 60068-2-6, Higher values are permissible when the wall-mounting bracket (ZS5301-0002) is used
Impact	15 g 6 ms, 10 g 11 ms 3 impacts/direction, 18 impacts in total	According to IEC 60068-2-27, Higher values are permissible when the wall-mounting bracket (ZS5301-0002) is used
Installation altitude	0 to 2000 m	Without restrictions
	2000 - 6000 m	Reduce the output power or the ambient temperature, see Fig. <i>Output current over installation altitude</i>  IEC 62103, EN 50178, overvoltage category II
Derating, installation altitude	60 W/1000 m or 5°C/1000 m	> 2000 m, see Fig. <i>Output current over installation altitude</i>
Overvoltage category	III	According to IEC 62103, 50178, installation altitudes up to 2000 m
	II	Installation altitudes between 2000 and 6000 m
Degree of pollution	2	According to IEC 62103, EN 50178, non-conductive
LABS-free	The device does not release any silicones or other paint-wetting impairment substances and is suitable for use in paint shops.	

<sup>1)</sup> The working temperature is identical to the room temperature or the ambient temperature and is defined as the air temperature 2 cm below the device.

<sup>2)</sup> Do not energize when condensation is present!

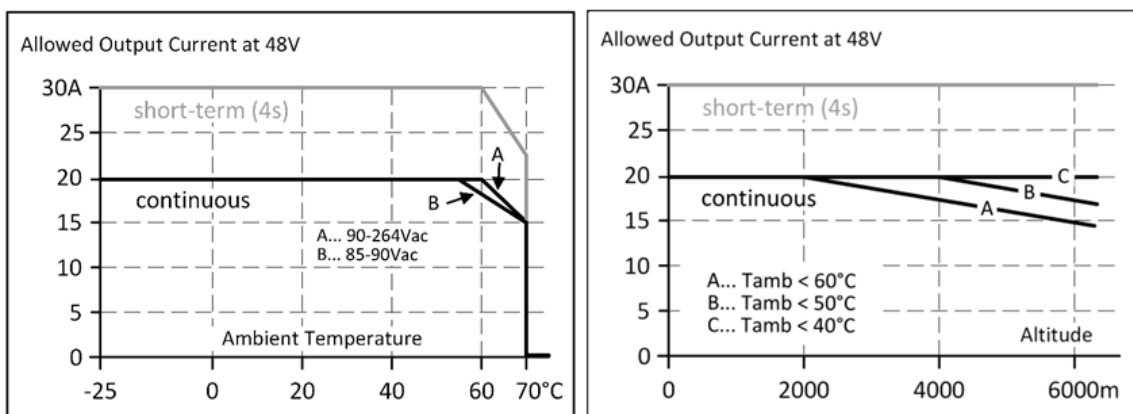

Fig. 17: Output current over ambient temperature; output current over installation altitude

### 3.16 Protective functions

Protective functions		
Output protection	Electronically protected against overload, no load and short circuits <sup>1)</sup>	
Output overvoltage protection	Typ. 58.8 Vdc Max. 60 Vdc	In the event of an internal power supply fault, a redundant circuit limits the maximum output voltage. The output switches off and automatically tries to switch on again.
Protection class	IP20	EN/IEC 60529
Ingress protection	> 5 mm	e.g., screws, small parts
Overtemperature protection	Yes	Output shutdown with automatic restart.
Protection against input transients	MOV (metal oxide varistor)	
Input fuse	included	Not user-replaceable

<sup>1)</sup> In the event of a protection event, audible noises may occur.

### 3.17 Safety features

Safety features		
Input/output isolation (double or reinforced isolation)	SELV	IEC/EN 60950-1
	PELV	IEC/EN 60204-1, EN 50178, IEC 62103, IEC 60364-4-41
Protection class	I	PE (protective conductor) connection required
Insulation resistance	> 5 MOhm	between input and output, measured with 500 Vdc
PE resistance	< 0.1 Ohm	
Leakage current	Typ. 0.39 mA / 1.0 mA	At 100 Vac, 50 Hz, TN, TT / IT network
	Typ. 0.56 mA / 1.43 mA	At 120 Vac, 60 Hz, TN, TT / IT network
	Typ. 0.90 mA / 2.25 mA	At 230 Vac, 50 Hz, TN, TT / IT network
	Max. 0.50 mA / 1.21 mA	At 110 Vac, 50 Hz, TN, TT / IT network
	Max. 0.71 mA / 1.73 mA	At 132 Vac, 60 Hz, TN, TT / IT network
	Max. 1.18 mA / 2.82 mA	At 264 Vac, 50 Hz, TN, TT / IT network

### 3.18 Dielectric strength

The output voltage is earth-free and has no ohmic connection to earth. Type and component tests are carried out by the manufacturer. Field tests can be performed in the field using suitable test equipment that ramps up the voltage with a slow ramp (2 s rising and 2 s falling). Connect all input terminals and all output poles to each other before performing the tests. During the test, set the cut-off current to the value shown in the table below.

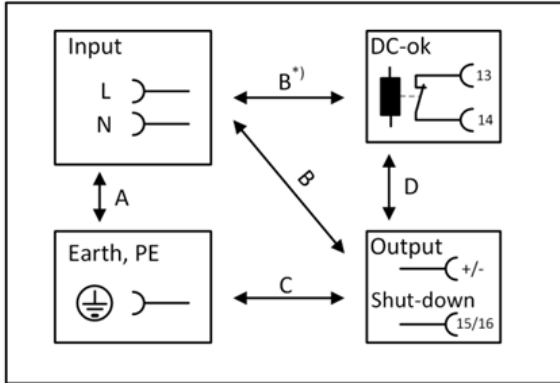



Fig. 18: Dielectric strength

B<sup>\*)</sup> When checking the input to DC-OK, make sure that the maximum voltage between DC-OK and the output is not exceeded (column D). When performing the test, we recommend connecting the DC OK contact pins and the output contact pins.

		A	B	C	D
Type test	60 s	2500 Vac	3000 Vac	500 Vac	500 Vac
Component test	5 s	2500 Vac	2500 Vac	500 Vac	500 Vac
Field test	5 s	2000 Vac	2000 Vac	500 Vac	500 Vac
Setting the cut-off current		> 20 mA	> 20 mA	> 40 mA	> 1 mA

To meet the PELV requirements according to EN 60204-1 section 6.4.1, we recommend connecting either the positive pole, the negative pole or another part of the output circuit to the protective conductor system. This avoids situations in which the load starts unexpectedly or cannot be disconnected if an unnoticed earth leakage occurs.

### 3.19 Declaration of conformity and approvals

	EU declaration of conformity
	UK Declaration of Conformity Trade conformity assessment for England, Scotland and Wales The UKCA mark indicates conformity with the UK Statutory Instruments 2016 No. 1101 (LVD) 2016 No. 1091 (EMC) and 2012 No. 3032 (RoHS)
	Registration for the Eurasian Customs Union market (Russia, Kazakhstan and Belarus)
	UL Certificate, UL508 Applicable for US and Canada
	DNV

### 3.20 Dimensions and weight

Dimensions and weight	
Overall width	125 mm
Height	124 mm
Depth	127 mm The height of the DIN rails must be added to the depth of the device to calculate the total installation depth required
Weight	1900 g
DIN rail	Use 35 mm DIN rails according to EN 60715 or EN 50022 with a height of 7.5 or 15 mm. The height of the DIN rail must be added to the depth of the unit (127 mm) to calculate the total installation depth required.
Housing material	Housing: Aluminum alloy Cover: Steel
Installation clearances	See chapter on <a href="#">Safety instructions and installation requirements</a> [▶ 8]

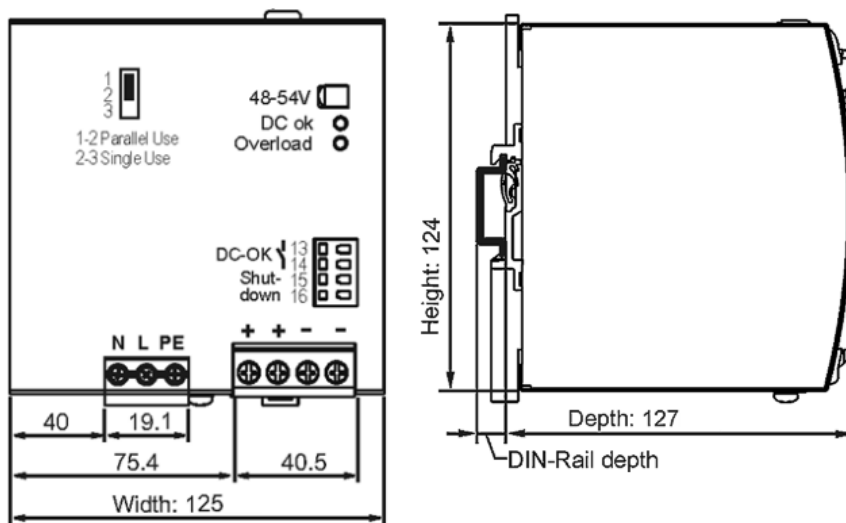

Fig. 19: Front/side view PS3011-4820-0000, all specifications in mm

## 4 Application notes

### 4.1 Repeated pulse load

Typically a load current is not constant and varies with time. This power supply is designed to support loads with a higher short-term power demand (extra power). The short-term duration is hardware-controlled by an output power manager and is available repeatedly. If the extra power load lasts longer than the hardware controller allows, the output voltage drops. Extra power is available again after the extra power recovery time has elapsed (see [Output](#) [► 13] chapter).

To avoid this, the following conditions must be met:

- The power requirement of the pulse must be less than 150% of the rated output power.
- The duration of the pulse power must be shorter than the permitted extra power time. (see [Output power section](#) [► 13])
- The average (RMS) output current must be below the specified continuous output current. If the effective current is higher, the device responds with a thermal shutdown after a certain time. The maximum duty cycle curve (Fig. *Repeated pulse loads, definitions; Max. duty cycle curve*) can be used to check whether the average output current is below the rated current.
- The duty cycle must be less than 0.75.

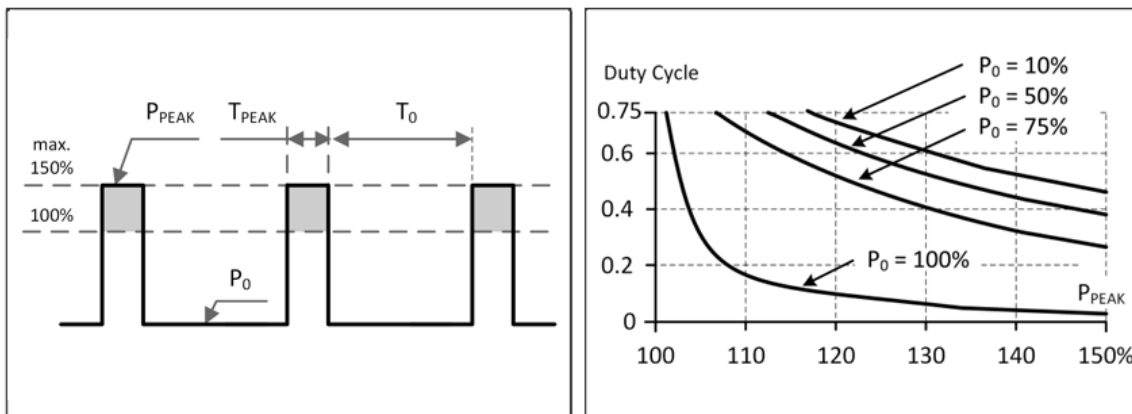

Fig. 20: Repeated pulse loads, definitions; Max. duty cycle curve

Key	
$P_0$	Base load (W)
$P_{PEAK}$	Pulse load (over 100%)
$T_0$	Duration between pulses (s)
$T_{PEAK}$	Pulse duration (s)

#### Calculation:

$$\text{Duty cycle} = T_{PEAK} / (T_{PEAK} + T_0)$$

$$T_0 = (T_{PEAK} - (\text{DutyCycle} \times T_{PEAK})) / \text{DutyCycle}$$

#### Example:

A load is operated continuously with 240 W (= 50% of the nominal output load). From time to time a peak power of 720 W (= 150% of the nominal output load) is required for 1 second.

- The question is: How often can this pulse be delivered without overloading the power supply?
  - Draw a vertical line at  $P_{PEAK} = 150\%$  and a horizontal line where the vertical line crosses the curve  $P_0 = 50\%$ . Read the maximum duty cycle from the duty cycle axis (= 0.37)
  - Calculate the required pause length  $T_0$  (base load):
  - Result: Required pause length = 1.7 s

- Max. repetition rate = pulse + pause length = 2.7 s

$$T_0 = (T_{PEAK} - (\text{DutyCycle} \times T_{PEAK})) / \text{DutyCycle} = (1 \text{ s} - (0.37 \times 1 \text{ s})) / 0.37 = \mathbf{1.7 \text{ s}}$$

**Further examples of pulse load tolerance**

<b>P<sub>PEAK</sub></b>	<b>P<sub>0</sub></b>	<b>T<sub>PEAK</sub></b>	<b>T<sub>0</sub></b>
1440 W	960 W	1 s	>25 s
1440 W	0 W	1 s	>1.3 s
1200 W	480 W	1 s	> 0.75 s
1440 W	480 W	0.1 s	>0.16 s
1440 W	480 W	1 s	>1.6 s
1440 W	480 W	3 s	>4.9 s

## 4.2 Peak current capability

The device can deliver peak currents (for up to several milliseconds) that are higher than the specified short-term currents.

This helps when starting loads with high current intensity. Magnetic coils, contactors and pneumatic modules often have a stationary coil and a pick-up coil. The inrush current requirement of the pick-up coil is several times higher than the stationary current and usually exceeds the rated output current (including extra power). The situation is exactly the same when starting a capacitive load.

The peak current capability also ensures safe operation of downstream circuit breakers of load circuits. The load circuits are often individually fused with circuit breakers or fuses. In the event of a short circuit or overload in a circuit, the fuse or circuit breaker needs a certain amount of overcurrent to open in time. This prevents a voltage drop in adjacent circuits.

The additional current (peak current) is supplied by the power converter and the built-in large-size output capacitors of the power supply. The capacitors are discharged during such an event, which leads to a voltage drop at the output. The following two examples show typical voltage drops for ohmic loads:

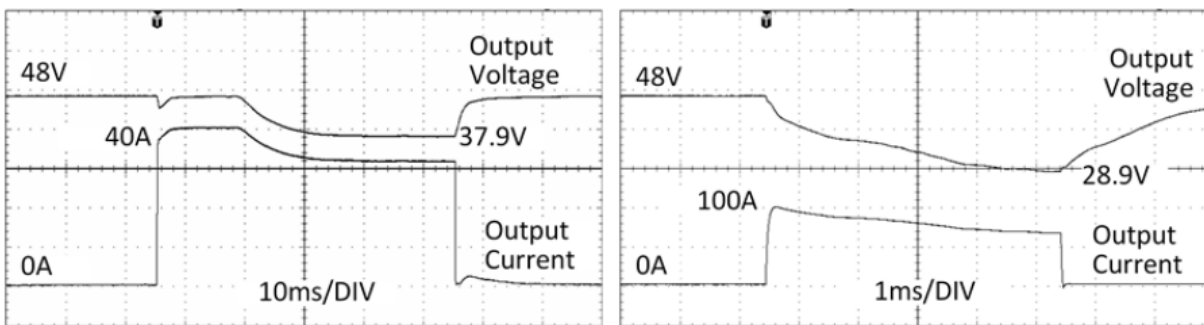

Fig. 21: 40 A peak current for 50 ms, typ. (2x nominal current); 100 A peak current for 5 ms, typ. (5x nominal current)

### ● Control of DC-OK relay

**i** Please note: The DC-OK relay is activated if the voltage drops by more than 10% for more than 1 ms.

Peak current voltage drops	
Typically from 48 V to 37.9 V	At 40 A for 50 ms, ohmic load
Typically from 48 V to 34.9 V	At 100 A for 2 ms, ohmic load
Typically from 48 V to 28.9 V	At 100 A for 5 ms, ohmic load



## 4.3 External input protection

The device is tested and approved for circuits up to 30 A (UL) and 32 A (IEC). External protection is only required if the supply line has a protection that is higher than this. Also check the local regulations and requirements. Local regulations may apply in some countries.

If an external fuse is required or used, minimum requirements must be taken into account to avoid false tripping of the circuit breaker.

- A circuit breaker with a minimum value of 16 A with B or C characteristic should be used if the device is used with AC 100 V or AC 120 V mains voltage (including AC 230 V).
- If the device is only used with AC 230 V mains voltage, a 10 A circuit breaker with B or C characteristic is sufficient.

## 4.4 Operation on two phases

The power supply can also be used on two phases of a three-phase system. Such a phase-to-phase connection is permissible as long as the supply voltage is below  $240\text{ V} + 10\%$ .

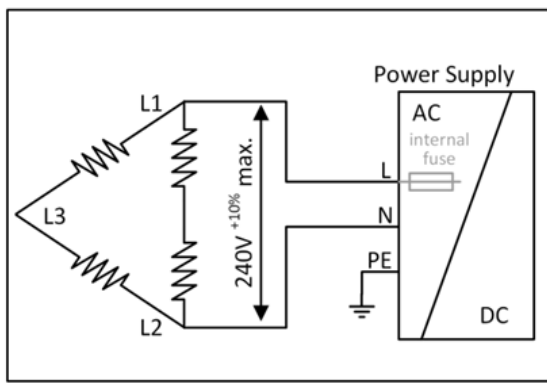

Fig. 22: Operation on two phases

Use a fuse or circuit breaker to protect the N input. The N input is not protected internally and is connected to the live conductor in this case. Suitable fuses or circuit breakers are specified in section [External input protection](#) [► 33].

## 4.5 Output circuit breakers

Standard circuit breakers (or UL1077 circuit breakers) are generally used for AC supply systems and can also be used for DC branches.

Circuit breakers are used to protect cables and circuits. If the ampere value and the characteristics of the circuit breaker are matched to the cable thickness used, the wiring is considered thermally safe, regardless of whether the circuit breaker opens or not.

To avoid voltage drops and situations with undervoltage in adjacent 48 V branches fed from the same source, a fast (magnetic) trip of the circuit breaker is desirable. Fast switch-off within 10 ms is required, which approximately corresponds to the bridging time of PLCs. This requires power supplies with high reserve current and large output capacitors. In addition, the impedance of the faulty branch must be sufficiently small for the current to actually flow. The following table contains typical test results that show which circuit breakers with B and C characteristics trip magnetically, depending on the wire cross-section and the wire length.

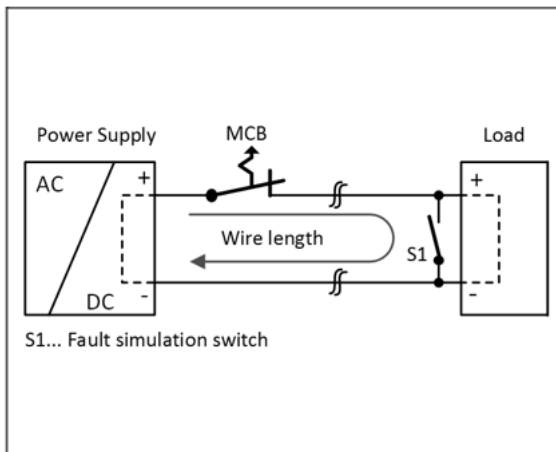

Fig. 23: Test circuit

Maximum wire length<sup>\*)</sup> for fast (magnetic) tripping:

	0.75 mm <sup>2</sup>	1.0 mm <sup>2</sup>	1.5 mm <sup>2</sup>	2.5 mm <sup>2</sup>
<b>C-2A</b>	68 m	89 m	>100 m	>100 m
<b>C-3A</b>	53 m	75 m	>100 m	>100 m
<b>C-4A</b>	44 m	57 m	88 m	>100 m
<b>C-6A</b>	18 m	25 m	38 m	58 m
<b>C-8A</b>	9 m	12 m	18 m	24 m
<b>C-10A</b>	8 m	11 m	16 m	23 m
<b>C-13A</b>	4 m	5 m	8 m	12 m

	0.75 mm <sup>2</sup>	1.0 mm <sup>2</sup>	1.5 mm <sup>2</sup>	2.5 mm <sup>2</sup>
<b>B-6A</b>	39 m	50 m	74 m	>100 m
<b>B-10A</b>	21 m	29 m	44 m	68 m
<b>B-13A</b>	13 m	21 m	34 m	52 m
<b>B-16A</b>	7 m	9 m	13 m	17 m
<b>B-20A</b>	2 m	3 m	4 m	5 m

<sup>\*)</sup> Don't forget to double the distance to the load (or the cable length) when calculating the total cable length (plus and minus cable).

## 4.6 Charging batteries

The power supply is not recommended for charging lead-acid batteries or maintenance-free batteries (SLA or VRLA batteries).

The PS3011-4820-0000 power supply cannot provide the recommended end-of-charge voltage of 55.0 V (at 20°C) for four 12 V lead-acid batteries in series.

## 4.7 Series connection

Power supplies of the same type can be connected in series to increase the output voltages. As many devices can be connected in series as necessary, as long as the sum of the output voltages does not exceed 150 Vdc. Voltages with a potential higher than 60 Vdc are no longer regarded as safety extra-low voltage and can be dangerous. Such voltages must be protected with a contact hazard protection.

- Grounding of the output is required if the sum of the output voltage is more than 60 Vdc.
- Avoid application of return voltage (e.g., from a braking motor or battery) to the output terminals.

### Restrictions:

- Maintain an installation distance of 15 mm (left/right) between two power supplies.
- Do not install the power supplies above each other.
- Power supplies connected in series should only be used in the standard installation position (terminals on the underside of the device).
- Note that leakage current, electromagnetic interference, inrush current, and harmonics increase when using multiple power supplies.

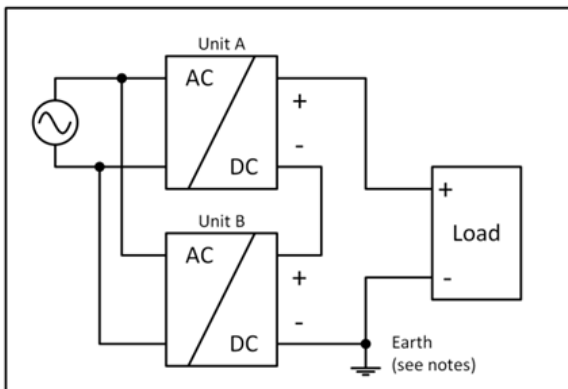

Fig. 24: Series connection

## 4.8 Parallel use to increase power

Power supplies of the same type from the PS3xxx series can be connected in parallel to increase the output power.

- The output voltage must be set to the same value ( $\pm 100$  mV) in "Single Use" mode and with the same load conditions on all devices, or the units can be left with the factory settings.
- After the settings have been made, the jumper on the front of the device must be changed from "Single Use" mode to "Parallel Use" mode in order to achieve load splitting.
  - In "Parallel Use" mode the output voltage is regulated such that the voltage at no load is approx. 4% higher than at nominal load. See also [Output \[► 13\]](#) chapter.
  - If no jumper is plugged in, the device is in "Single Use" mode. The factory setting is also the "Single Use" mode.
- If more than three devices are connected in parallel, a fuse or circuit breaker with a rated current of 30 A or 32 A is required at each output. Alternatively a diode can be used.
- Energize all devices simultaneously to avoid overload Hiccup mode. If the output has been in Hiccup mode due to overload or short circuit and the required output current is higher than the current of a device, it may be necessary to ramp up and shut down the input power (turn off for at least five seconds).

### Restrictions:

- Maintain an installation distance of 15 mm (left/right) between two power supplies.
- Do not install the power supplies above each other.
- In "Parallel Use" mode power supplies should only be used in the standard installation position (terminals on the underside of the device), not in other installation positions or under other conditions that require a reduction in the output current (e.g., installation altitude, operation at temperatures about  $+60^{\circ}\text{C}$ , ...).
- Note that leakage current, electromagnetic interference, inrush current, and harmonics increase when using multiple power supplies.

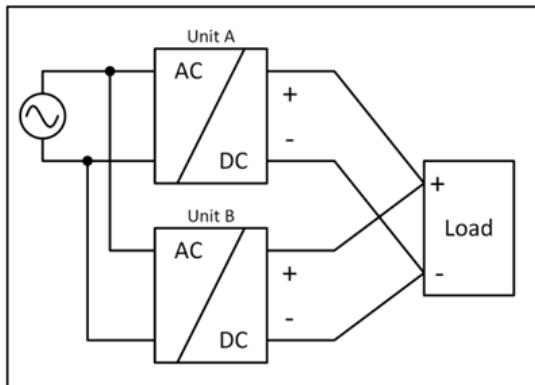

Fig. 25: Parallel connection

## 4.9 Parallel use for redundancy

### 1+1 Redundancy

It is possible to connect power supplies in parallel for redundancy operation in order to achieve better system availability. Redundant systems provide a certain amount of additional power to operate the load when a power supply unit fails. The simplest method is to connect two power supplies in parallel. This is called 1+1 redundancy. If one power supply fails, the other can automatically supply the load current without interruption.

The 1+1 redundancy allows ambient temperatures up to +70°C.

#### **i** Notes on parallel use for 1+1 redundancy

- Be sure to use a redundancy module in order to decouple devices from one another. This prevents the defective device from becoming a load for the other device and the output voltage no longer being maintainable.
- Note that leakage current, EMI, input inrush current and harmonics increase when using multiple devices.

#### Recommendations for the construction of redundant power supply systems:

- Power supplies that contain a DC-OK signal contact are best suited for the construction of redundant power supply systems.
  - Use this DC-OK signal contact to monitor the individual power supplies.
- Use separate grids for each power supply whenever possible.
- It is recommended to set the output voltages of all devices to the same value ( $\pm 100$  mV) or to leave them at the factory setting.

#### Wiring example:

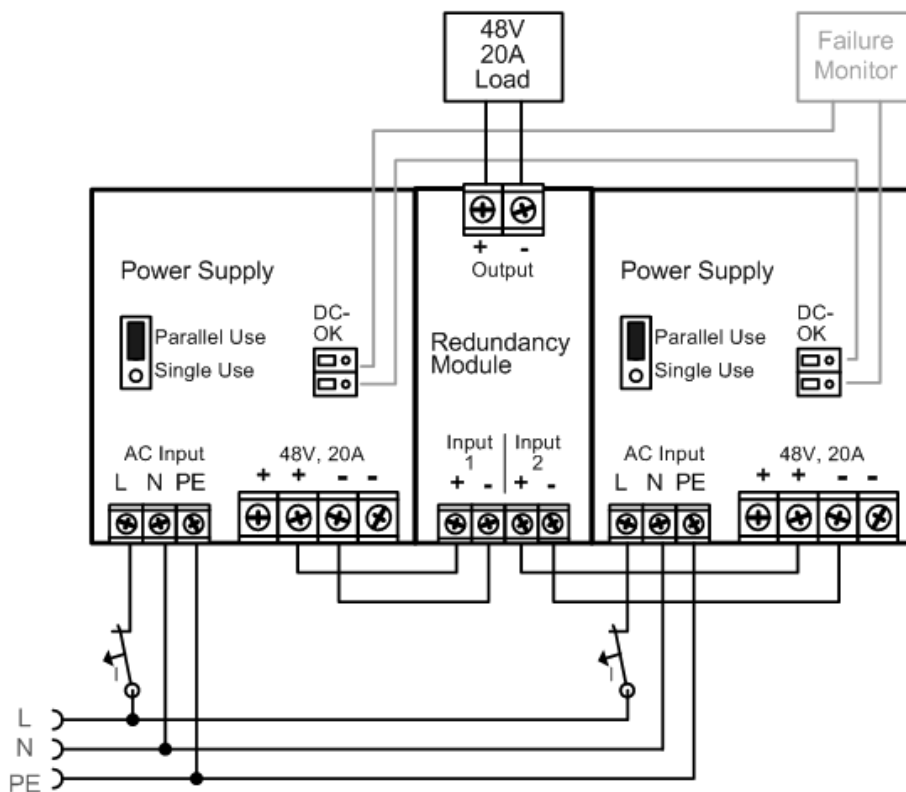

Fig. 26: Wiring for 1+1 redundancy with a PS9421-4840-0000 redundancy module

## 4.10 Inductive and capacitive loads

The device is designed to supply all load types, including capacitive and inductive loads.

If very large capacitors such as EDLCs (electric double-layer capacitors or "UltraCaps") with a capacitance of more than 1 F are connected to the output, the device charges the capacitor in Hiccup mode if necessary (see [Output \[▶\\_14\]](#) chapter).

## 4.11 Back-feeding loads

Loads such as braking motors or inductors can feed back voltage to the power supply. This feature is also known as back EMF. (electromagnetic force).

This power supply is stable and will not malfunction if a load is feeding back voltage to the power supply. It is irrelevant whether the power supply is switched on or off.

The maximum permissible feed-back voltage is 63 Vdc. The absorbing energy can be calculated according to the large built-in output capacitor indicated in the output data, see [Output \[► 13\]](#) chapter.

## 4.12 Use in a tightly sealed enclosure

When the power supply is installed in a tightly sealed enclosure, the temperature inside the housing is higher than outside. In this case, the temperature inside the housing is considered the ambient temperature for the power supply.

In the following test arrangement, the device is placed at the center of the housing, and there are no other heat-generating objects in the housing. The load is placed outside the housing.

The temperature sensor inside the housing is placed at the center of the right side of the power supply at a distance of 2 cm.

The following measurement results can be used as a reference to estimate the temperature rise within the housing.

Housing size:

254x180x165 mm Rittal housing, protection class IP66 PK 9522 100, plastic

Input voltage:

230 Vac

Load:

48 V, 16 A; (=80%)

Temperature inside the housing:

65.6°C

Temperature outside the housing:

24.1°C

Temperature increase:

41.5 K

## 4.13 Installation positions

Installation positions other than the input connections at the bottom and the output at the top require a reduction of the continuous output power or a limitation of the maximum permissible ambient temperature.

The extent of the reduction influences the life expectancy of the power supply. Therefore, two different derating curves for continuous operation are provided below:

Curve A1: Recommended output current.

Curve A2: Max. permissible output current (results in about half the life expectancy of A1).

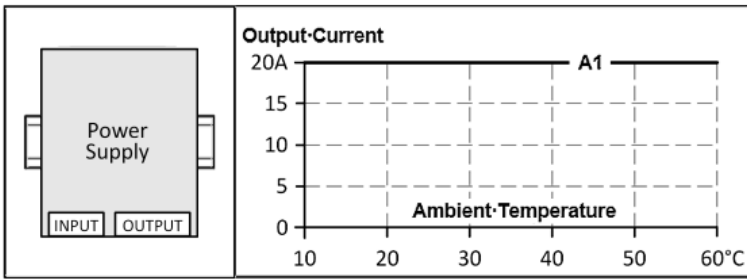

Fig. 27: Installation position A (standard installation position)

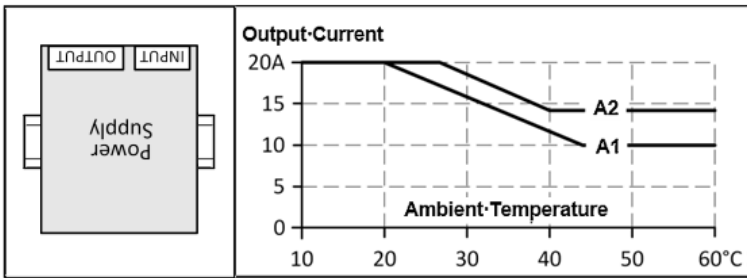

Fig. 28: Installation position B (upside down)

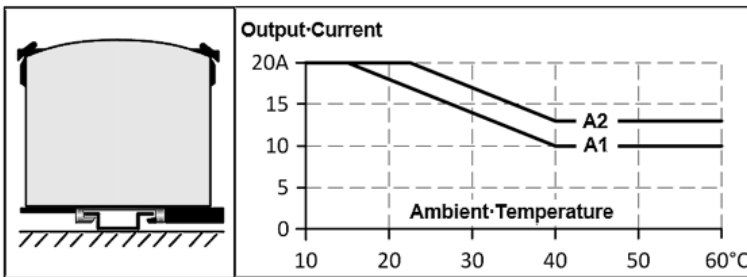

Fig. 29: Installation position C (table mounting)

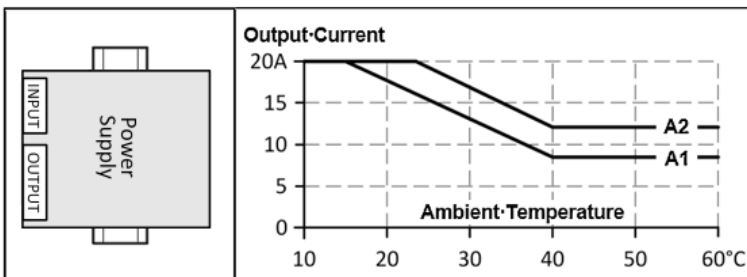

Fig. 30: Installation position D (horizontal clockwise)

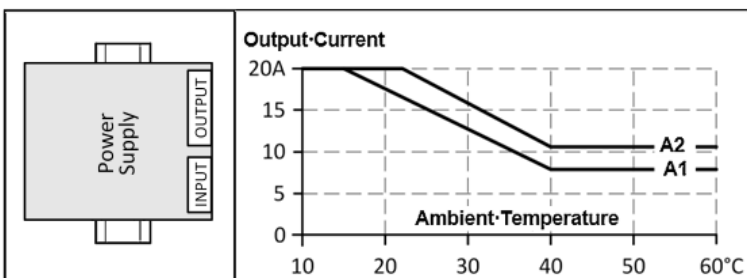

Fig. 31: Installation position E (horizontal counterclockwise)



## 5 Disposal



Products marked with a crossed-out wheeled bin shall not be discarded with the normal waste stream. The device is considered as waste electrical and electronic equipment. The national regulations for the disposal of waste electrical and electronic equipment must be observed.

## 6 Appendix

### 6.1 Accessories

#### 6.1.1 Redundancy and buffer modules

Power supply	Accessories	
	Redundancy module	Buffer module
PS3011-4820-0000	PS9421-4840-0000	PS9031-4820-0001

##### PS9421-4840-0000– Redundancy Module



The PS9421-4840-0000 is a redundancy module that can be used for the construction of 1+1 and N+1 redundancy systems.

It has two input channels, to which power supplies with output currents of up to 20 A can be connected, and one output that can carry nominal currents of up to 40 A.

The redundancy module uses MOSFET technology instead of diodes for decoupling the two input channels. This reduces the heat development and the voltage drop between input and output. Due to the low power loss, the device is very narrow and requires a width of just 46 mm on the DIN rail.

Large connection terminals enable secure and fast installation.

The redundancy module requires no additional auxiliary voltage.

Due to the international approvals package, the device is suitable for virtually every application.

Observe the connection instructions in the chapter "[Parallel use for redundancy](#) [[▶ 37](#)]"

##### PS9031-4820-0001– Buffer Module

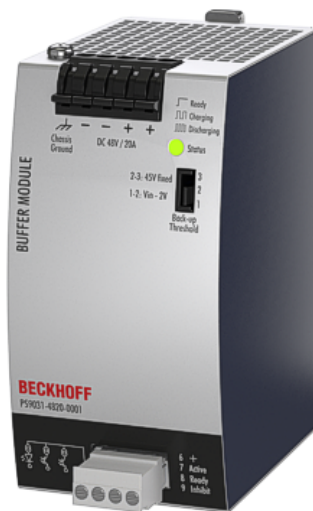

The PS9031-4820-0001 buffer module is an additional device for 48 V DC power supply units. It supplies power to bridge typical mains power failures or extends the hold-up time after switching off the AC voltage.

If the power supply unit supplies sufficient voltage, the buffer module stores energy in the integrated electrolytic capacitors. In the event of a failure of the mains voltage, the stored energy is supplied to the DC bus in a controlled process.

The buffer module can be connected at any point in parallel with the load circuit and does not require any control wiring.

A buffer module can provide 20 A of additional power and can be added in parallel to increase the output current or hold-up time.

#### 6.1.2 Mounting accessories

Power supply	Accessories	
	Wall mounting	Side mounting
PS3011-4820-0000	ZS5301-0002	

**ZS5301-0002 – Bracket for wall mounting**

This bracket is used to mount the devices to a wall or panel without using a DIN rail.

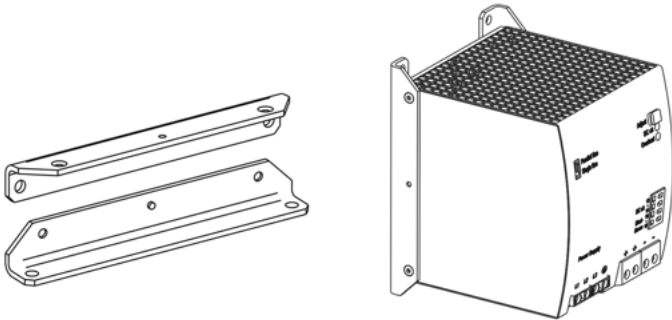

Fig. 32: ZS5301-0002, isometric view

## 6.2 Documentation issue status

Version	Comment
1.5.0	<ul style="list-style-type: none"> <li>• Update chapter "Overview"</li> <li>• Update chapter "Declaration of conformity and approvals"</li> <li>• Update structure</li> </ul>
1.4	<ul style="list-style-type: none"> <li>• Update structure</li> </ul>
1.3	<ul style="list-style-type: none"> <li>• Update chapter "Parallel use to increase power"</li> </ul>
1.2	<ul style="list-style-type: none"> <li>• Update chapter "Overview"</li> <li>• Update chapter "Declaration of conformity and approvals"</li> <li>• Chapters "Parallel use for redundancy" and "Disposal" added</li> <li>• Update chapter "Accessories"</li> <li>• Update structure</li> </ul>
1.1	<ul style="list-style-type: none"> <li>• First public issue</li> <li>• Corrections</li> </ul>
1.0	<ul style="list-style-type: none"> <li>• unpublished</li> </ul>
0.2	<ul style="list-style-type: none"> <li>• Addenda &amp; corrections</li> </ul>
0.1	<ul style="list-style-type: none"> <li>• Preliminary documentation for PS3011-4820-0000</li> </ul>

## 6.3 Support and Service

Beckhoff and their partners around the world offer comprehensive support and service, making available fast and competent assistance with all questions related to Beckhoff products and system solutions.

### Beckhoff's branch offices and representatives

Please contact your Beckhoff branch office or representative for local support and service on Beckhoff products!

The addresses of Beckhoff's branch offices and representatives round the world can be found on her internet pages: [www.beckhoff.com](http://www.beckhoff.com)

You will also find further documentation for Beckhoff components there.

### Support

The Beckhoff Support offers you comprehensive technical assistance, helping you not only with the application of individual Beckhoff products, but also with other, wide-ranging services:

- support
- design, programming and commissioning of complex automation systems
- and extensive training program for Beckhoff system components

Hotline: +49 5246 963 157  
e-mail: [support@beckhoff.com](mailto:support@beckhoff.com)  
web: [www.beckhoff.com/support](http://www.beckhoff.com/support)

### Service

The Beckhoff Service Center supports you in all matters of after-sales service:

- on-site service
- repair service
- spare parts service
- hotline service

Hotline: +49 5246 963 460  
e-mail: [service@beckhoff.com](mailto:service@beckhoff.com)  
web: [www.beckhoff.com/service](http://www.beckhoff.com/service)

### Headquarters Germany

Beckhoff Automation GmbH & Co. KG

Hülshorstweg 20  
33415 Verl  
Germany

Phone: +49 5246 963 0  
e-mail: [info@beckhoff.com](mailto:info@beckhoff.com)  
web: [www.beckhoff.com](http://www.beckhoff.com)



More Information:

[www.beckhoff.com/ps3011-4820-0000](http://www.beckhoff.com/ps3011-4820-0000)

Beckhoff Automation GmbH & Co. KG  
Hülshorstweg 20  
33415 Verl  
Germany  
Phone: +49 5246 9630  
[info@beckhoff.com](mailto:info@beckhoff.com)  
[www.beckhoff.com](http://www.beckhoff.com)

