

Documentation | EN

EL6631, EL6632

PROFINET CONTROLLER Supplement



Table of contents

1	Foreword	5
1.1	Notes on the documentation	5
1.2	Guide through documentation	6
1.3	Notes on information security.....	7
1.4	Safety instructions	8
1.5	Documentation issue status	9
1.6	Version identification of EtherCAT devices	10
1.6.1	General notes on marking.....	10
1.6.2	Version identification of EL terminals.....	11
1.6.3	Beckhoff Identification Code (BIC).....	12
1.6.4	Electronic access to the BIC (eBIC).....	14
2	Product description	16
2.1	Introduction	16
2.2	Technical data.....	17
2.3	Activation of the PROFINET Controller Supplement.....	17
2.4	EL6631 - PROFINET-RT-Controller.....	21
2.5	EL6631 - Technical data	22
2.6	EL6631 - LEDs.....	23
2.7	EL6632 - PROFINET-IRT-Controller.....	25
2.8	EL6632 - Technical data	26
3	Mounting and wiring	28
3.1	Instructions for ESD protection	28
3.2	Explosion protection	29
3.2.1	ATEX - Special conditions (standard temperature range).....	29
3.2.2	IECEX - Special conditions.....	30
3.2.3	Continuative documentation for ATEX and IECEX.....	31
3.3	UL notice	32
3.4	Note - power supply	33
3.5	Installation positions.....	34
3.6	Note on shielding	36
3.7	Mounting and demounting - traction lever unlocking.....	37
3.8	Mounting and demounting - top front unlocking	39
3.9	Disposal	41
4	PN controller protocol	42
4.1	Integration of the TwinCAT PROFINET controller protocol via a RealTimeEthernet interface	42
4.2	Integration of the TwinCAT PROFINET controller protocol via an EL663x interface	43
4.3	Settings / diagnostics	44
4.3.1	PROFINET	44
4.3.2	Task configuration.....	50
4.3.3	PROFINET controller-specific settings.....	51
4.3.4	Analysis of the box states	52
4.3.5	Diagnosis history on the controller protocol	55
4.3.6	Cyclic data.....	56

4.3.7	Acyclic data	57
5	Devices at protocol	59
5.1	Appending PROFINET devices	59
5.2	Comparison of nominal and actual configuration	60
5.3	Settings	64
5.3.1	Project planning of the PROFINET device	64
5.3.2	BK9xx3	65
5.3.3	EL663x	66
5.3.4	IRT Controller	66
5.3.5	Shared Device	67
5.4	Modules	69
5.4.1	Diagnosis at module level	69
5.4.2	Diagnosis at submodule level	69
5.4.3	Interface Submodule	69
5.4.4	Port Submodule	70
5.4.5	Real / virtual submodules	72
6	TwinCAT library and programming	73
6.1	Overview	73
6.2	Functions	74
6.2.1	I&M	74
6.2.2	Port	83
6.2.3	AlarmDiag	85
6.3	Data Structures	87
6.3.1	I&M	87
6.3.2	Port	89
6.3.3	AlarmDiag	90
6.3.4	Enumeration types for PROFINET alarms	91
7	Appendix	92
7.1	FAQ	92
7.1.1	Device description file (GSDML) / DAP (DeviceAccessPoint)	92
7.1.2	Task configuration	94
7.1.3	EL663x-00x0 EtherCAT Terminals	95
7.1.4	BoxStates of the PROFINET devices	97
7.1.5	Diagnostic status under TIA	98
7.2	EtherCAT AL Status Codes	98
7.3	Firmware compatibility	99
7.4	Firmware Update EL/ES/EM/ELM/EP/EPP/ERPxxxx	100
7.4.1	Device description ESI file/XML	101
7.4.2	Firmware explanation	104
7.4.3	Updating controller firmware *.efw	105
7.4.4	FPGA firmware *.rbf	107
7.4.5	Simultaneous updating of several EtherCAT devices	111
7.5	Support and Service	112

1 Foreword

1.1 Notes on the documentation

Intended audience

This description is only intended for the use of trained specialists in control and automation engineering who are familiar with the applicable national standards.

It is essential that the documentation and the following notes and explanations are followed when installing and commissioning these components.

The qualified personnel is obliged to always use the currently valid documentation.

The responsible staff must ensure that the application or use of the products described satisfy all the requirements for safety, including all the relevant laws, regulations, guidelines and standards.

Disclaimer

The documentation has been prepared with care. The products described are, however, constantly under development.

We reserve the right to revise and change the documentation at any time and without prior announcement.

No claims for the modification of products that have already been supplied may be made on the basis of the data, diagrams and descriptions in this documentation.

Trademarks

Beckhoff®, TwinCAT®, TwinCAT/BSD®, TC/BSD®, EtherCAT®, EtherCAT G®, EtherCAT G10®, EtherCAT P®, Safety over EtherCAT®, TwinSAFE®, XFC®, XTS® and XPlanar® are registered trademarks of and licensed by Beckhoff Automation GmbH. Other designations used in this publication may be trademarks whose use by third parties for their own purposes could violate the rights of the owners.

Patent Pending

The EtherCAT Technology is covered, including but not limited to the following patent applications and patents: EP1590927, EP1789857, EP1456722, EP2137893, DE102015105702 with corresponding applications or registrations in various other countries.



EtherCAT® is registered trademark and patented technology, licensed by Beckhoff Automation GmbH, Germany.

Copyright

© Beckhoff Automation GmbH & Co. KG, Germany.

The reproduction, distribution and utilization of this document as well as the communication of its contents to others without express authorization are prohibited.

Offenders will be held liable for the payment of damages. All rights reserved in the event of the grant of a patent, utility model or design.

1.2 Guide through documentation

NOTICE



Further components of documentation

This documentation describes device-specific content. It is part of the modular documentation concept for Beckhoff I/O components. For the use and safe operation of the device / devices described in this documentation, additional cross-product descriptions are required, which can be found in the following table.

Title	Description
EtherCAT System Documentation (PDF)	<ul style="list-style-type: none"> • System overview • EtherCAT basics • Cable redundancy • Hot Connect • EtherCAT devices configuration
Explosion Protection for Terminal Systems (PDF)	Notes on the use of the Beckhoff terminal systems in hazardous areas according to ATEX and IECEx
Infrastructure for EtherCAT/Ethernet (PDF)	Technical recommendations and notes for design, implementation and testing
Software Declarations I/O (PDF)	Open source software declarations for Beckhoff I/O components

The documentations can be viewed at and downloaded from the Beckhoff website (www.beckhoff.com) via:

- the “Documentation and Download” area of the respective product page,
- the [Download finder](#),
- the [Beckhoff Information System](#).

If you have any suggestions or proposals for our documentation, please send us an e-mail stating the documentation title and version number to: documentation@beckhoff.com

1.3 Notes on information security

The products of Beckhoff Automation GmbH & Co. KG (Beckhoff), insofar as they can be accessed online, are equipped with security functions that support the secure operation of plants, systems, machines and networks. Despite the security functions, the creation, implementation and constant updating of a holistic security concept for the operation are necessary to protect the respective plant, system, machine and networks against cyber threats. The products sold by Beckhoff are only part of the overall security concept. The customer is responsible for preventing unauthorized access by third parties to its equipment, systems, machines and networks. The latter should be connected to the corporate network or the Internet only if appropriate protective measures have been set up.

In addition, the recommendations from Beckhoff regarding appropriate protective measures should be observed. Further information regarding information security and industrial security can be found in our <https://www.beckhoff.com/secguide>.

Beckhoff products and solutions undergo continuous further development. This also applies to security functions. In light of this continuous further development, Beckhoff expressly recommends that the products are kept up to date at all times and that updates are installed for the products once they have been made available. Using outdated or unsupported product versions can increase the risk of cyber threats.

To stay informed about information security for Beckhoff products, subscribe to the RSS feed at <https://www.beckhoff.com/secinfo>.

1.4 Safety instructions

Safety regulations

Please note the following safety instructions and explanations!
Product-specific safety instructions can be found on following pages or in the areas mounting, wiring, commissioning etc.

Exclusion of liability

All the components are supplied in particular hardware and software configurations appropriate for the application. Modifications to hardware or software configurations other than those described in the documentation are not permitted, and nullify the liability of Beckhoff Automation GmbH & Co. KG.

Personnel qualification

This description is only intended for trained specialists in control, automation and drive engineering who are familiar with the applicable national standards.

Signal words

The signal words used in the documentation are classified below. In order to prevent injury and damage to persons and property, read and follow the safety and warning notices.

Personal injury warnings

⚠ DANGER

Hazard with high risk of death or serious injury.

⚠ WARNING

Hazard with medium risk of death or serious injury.

⚠ CAUTION

There is a low-risk hazard that could result in medium or minor injury.

Warning of damage to property or environment

NOTICE

The environment, equipment, or data may be damaged.

Information on handling the product



This information includes, for example:
recommendations for action, assistance or further information on the product.

1.5 Documentation issue status

Version	Comment
2.8.0	<ul style="list-style-type: none"> • Update chapter "Mounting and wiring" • Update structure
2.7	<ul style="list-style-type: none"> • Update chapter "Technical data" • Update structure
2.6	<ul style="list-style-type: none"> • Update chapter "Technical data" • Chapter "IECEX - Special conditions" added • Update structure
2.5	<ul style="list-style-type: none"> • Chapter "Recommended mounting rails" removed • Update chapter "Technical data" • Update structure
2.4	<ul style="list-style-type: none"> • Update chapter "Technical data" • Addenda chapter "Notes on information security" • Update structure • Update revision status
2.3	<ul style="list-style-type: none"> • Update revision status • Update structure • Update chapter "Settings/Diagnostics" • Update chapter "Devices at protocol"
2.2	<ul style="list-style-type: none"> • Update revision status • Update chapter "Version identification of EtherCAT devices"
2.1	<ul style="list-style-type: none"> • Update chapter "Acyclic data" • Update chapter "Technical data" • Update structure • Update revision status
2.0	<ul style="list-style-type: none"> • Migration • Update structure • Update revision status
1.0	<ul style="list-style-type: none"> • Addenda and 1st public issue
0.4	<ul style="list-style-type: none"> • Amendments
0.3	<ul style="list-style-type: none"> • Revised controller documentation
0.2	<ul style="list-style-type: none"> • Revised controller documentation
0.1	<ul style="list-style-type: none"> • First version

1.6 Version identification of EtherCAT devices

1.6.1 General notes on marking

Designation

A Beckhoff EtherCAT device has a 14-digit designation, made up of

- family key
- type
- version
- revision

Example	Family	Type	Version	Revision
EL3314-0000-0016	EL terminal 12 mm, non-pluggable connection level	3314 4-channel thermocouple terminal	0000 basic type	0016
ES3602-0010-0017	ES terminal 12 mm, pluggable connection level	3602 2-channel voltage measurement	0010 high-precision version	0017
CU2008-0000-0000	CU device	2008 8-port fast ethernet switch	0000 basic type	0000

Notes

- The elements mentioned above result in the **technical designation**. EL3314-0000-0016 is used in the example below.
- EL3314-0000 is the order identifier, in the case of "-0000" usually abbreviated to EL3314. "-0016" is the EtherCAT revision.
- The **order identifier** is made up of
 - family key (EL, EP, CU, ES, KL, CX, etc.)
 - type (3314)
 - version (-0000)
- The **revision** -0016 shows the technical progress, such as the extension of features with regard to the EtherCAT communication, and is managed by Beckhoff.
In principle, a device with a higher revision can replace a device with a lower revision, unless specified otherwise, e.g. in the documentation.
Associated and synonymous with each revision there is usually a description (ESI, EtherCAT Slave Information) in the form of an XML file, which is available for download from the Beckhoff web site.
From 2014/01 the revision is shown on the outside of the IP20 terminals, see Fig. "EL2872 with revision 0022 and serial number 01200815".
- The type, version and revision are read as decimal numbers, even if they are technically saved in hexadecimal.

1.6.2 Version identification of EL terminals

The serial number/ data code for Beckhoff IO devices is usually the 8-digit number printed on the device or on a sticker. The serial number indicates the configuration in delivery state and therefore refers to a whole production batch, without distinguishing the individual modules of a batch.

Structure of the serial number: **KK YY FF HH**

KK - week of production (CW, calendar week)

YY - year of production

FF - firmware version

HH - hardware version

Example with serial number 12 06 3A 02:

12 - production week 12

06 - production year 2006

3A - firmware version 3A

02 - hardware version 02



Fig. 1: EL2872 with revision 0022 and serial number 01200815

1.6.3 Beckhoff Identification Code (BIC)

The Beckhoff Identification Code (BIC) is increasingly being applied to Beckhoff products to uniquely identify the product. The BIC is represented as a Data Matrix Code (DMC, code scheme ECC200), the content is based on the ANSI standard MH10.8.2-2016.

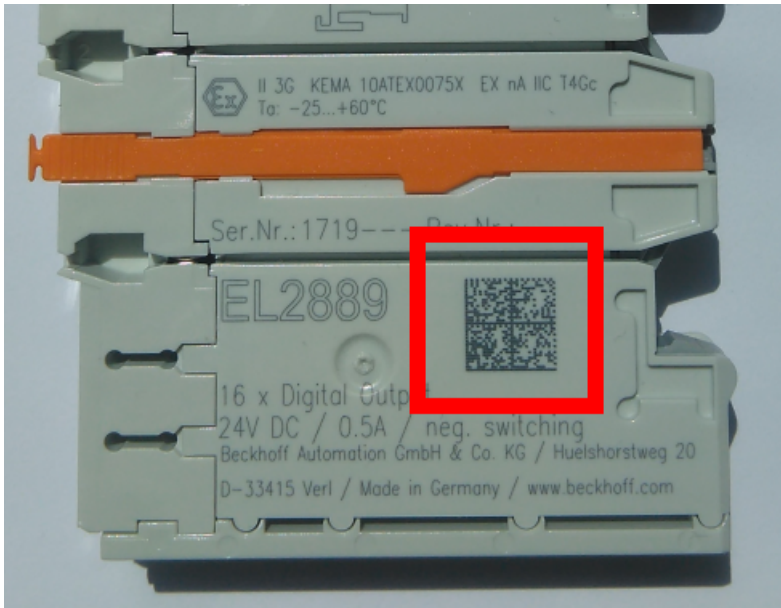

Fig. 2: BIC as data matrix code (DMC, code scheme ECC200)

The BIC will be introduced step by step across all product groups.

Depending on the product, it can be found in the following places:

- on the packaging unit
- directly on the product (if space suffices)
- on the packaging unit and the product

The BIC is machine-readable and contains information that can also be used by the customer for handling and product management.

Each piece of information can be uniquely identified using the so-called data identifier (ANSI MH10.8.2-2016). The data identifier is followed by a character string. Both together have a maximum length according to the table below. If the information is shorter, spaces are added to it.

Following information is possible, positions 1 to 4 are always present, the other according to need of production:

Position	Type of information	Explanation	Data identifier	Number of digits incl. data identifier	Example
1	Beckhoff order number	Beckhoff order number	1P	8	1P 072222
2	Beckhoff Traceability Number (BTN)	Unique serial number, see note below	SBTN	12	SBTN k4p562d7
3	Article description	Beckhoff article description, e.g. EL1008	1K	32	1K EL1809
4	Quantity	Quantity in packaging unit, e.g. 1, 10, etc.	Q	6	Q1
5	Batch number	Optional: Year and week of production	2P	14	2P 401503180016
6	ID/serial number	Optional: Present-day serial number system, e.g. with safety products	51S	12	51S 678294
7	Variant number	Optional: Product variant number on the basis of standard products	30P	32	30P F971, 2*K183
...					

Further types of information and data identifiers are used by Beckhoff and serve internal processes.

Structure of the BIC

Example of composite information from positions 1 to 4 and with the above given example value on position 6. The data identifiers are highlighted in bold font:

1P072222**SBTN**k4p562d7**1K**EL1809 **Q1** **51S**678294

Accordingly as DMC:



Fig. 3: Example DMC **1P**072222**SBTN**k4p562d7**1K**EL1809 **Q1** **51S**678294

BTN

An important component of the BIC is the Beckhoff Traceability Number (BTN, position 2). The BTN is a unique serial number consisting of eight characters that will replace all other serial number systems at Beckhoff in the long term (e.g. batch designations on IO components, previous serial number range for safety products, etc.). The BTN will also be introduced step by step, so it may happen that the BTN is not yet coded in the BIC.

NOTICE
<p>This information has been carefully prepared. However, the procedure described is constantly being further developed. We reserve the right to revise and change procedures and documentation at any time and without prior notice. No claims for changes can be made from the information, illustrations and descriptions in this documentation.</p>

1.6.4 Electronic access to the BIC (eBIC)

Electronic BIC (eBIC)

The Beckhoff Identification Code (BIC) is applied to the outside of Beckhoff products in a visible place. If possible, it should also be electronically readable.

The interface that the product can be electronically addressed by is crucial for the electronic readout.

K-bus devices (IP20, IP67)

Currently, no electronic storage or readout is planned for these devices.

EtherCAT devices (IP20, IP67)

All Beckhoff EtherCAT devices have an ESI-EEPROM which contains the EtherCAT identity with the revision number. The EtherCAT slave information, also colloquially known as the ESI/XML configuration file for the EtherCAT master, is stored in it. See the corresponding chapter in the EtherCAT system manual ([Link](#)) for the relationships.

Beckhoff also stores the eBIC in the ESI-EEPROM. The eBIC was introduced into Beckhoff IO production (terminals, box modules) in 2020; as of 2023, implementation is largely complete.

The user can electronically access the eBIC (if present) as follows:

- With all EtherCAT devices, the EtherCAT master (TwinCAT) can read the eBIC from the ESI-EEPROM
 - From TwinCAT 3.1 build 4024.11, the eBIC can be displayed in the online view.
 - To do this, check the "Show Beckhoff Identification Code (BIC)" checkbox under EtherCAT → Advanced Settings → Diagnostics:

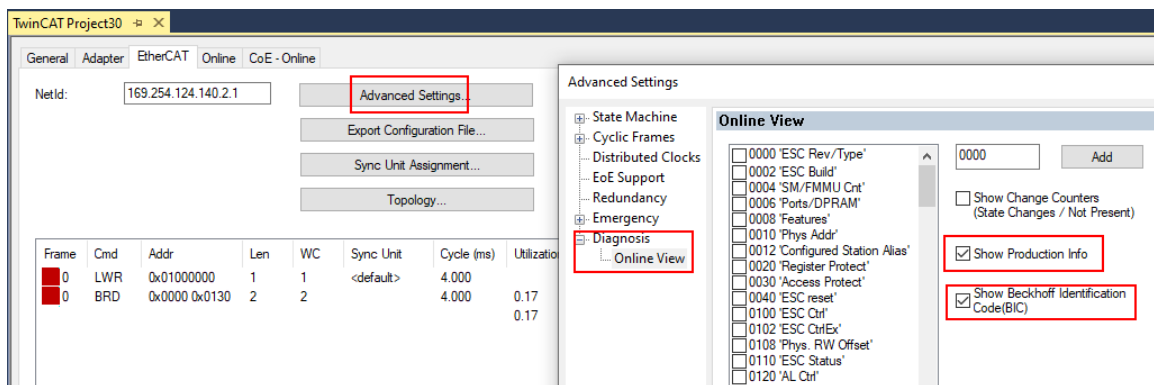

- The BTN and its contents are then displayed:

No	Addr	Name	State	CRC	Fw	Hw	Production Data	ItemNo	BTN	Description	Quantity	BatchNo	SerialNo
1	1001	Term 1 (EK1100)	OP	0.0	0	0	---						
2	1002	Term 2 (EL1018)	OP	0.0	0	0	2020 KW36 Fr	072222	k4p562d7	EL1809	1		678294
3	1003	Term 3 (EL3204)	OP	0.0	7	6	2012 KW24 Sa						
4	1004	Term 4 (EL2004)	OP	0.0	0	0	---	072223	k4p562d7	EL2004	1		678295
5	1005	Term 5 (EL1008)	OP	0.0	0	0	---						
6	1006	Term 6 (EL2008)	OP	0.0	0	12	2014 KW14 Mo						
7	1007	Term 7 (EK1110)	OP	0	1	8	2012 KW25 Mo						

- Note: As shown in the figure, the production data HW version, FW version, and production date, which have been programmed since 2012, can also be displayed with "Show production info".
- Access from the PLC: From TwinCAT 3.1. build 4024.24, the functions *FB_EcReadBIC* and *FB_EcReadBTN* for reading into the PLC are available in the *Tc2_EtherCAT* library from v3.3.19.0.
- EtherCAT devices with a CoE directory may also have the object 0x10E2:01 to display their own eBIC, which can also be easily accessed by the PLC:

- The device must be in PREOP/SAFEOP/OP for access:

Index	Name	Flags	Value
1000	Device type	RO	0x015E1389 (22942601)
1008	Device name	RO	ELM3704-0000
1009	Hardware version	RO	00
100A	Software version	RO	01
100B	Bootloader version	RO	J0.1.27.0
1011:0	Restore default parameters	RO	> 1 <
1018:0	Identity	RO	> 4 <
10E2:0	Manufacturer-specific Identification C...	RO	> 1 <
10E2:01	SubIndex 001	RO	1P158442SBTN0008jckp1KELM3704 Q1 2P482001000016
10F0:0	Backup parameter handling	RO	> 1 <
10F3:0	Diagnosis History	RO	> 21 <
10F8	Actual Time Stamp	RO	0x170bfb277e

- The object 0x10E2 will be preferentially introduced into stock products in the course of necessary firmware revision.
- From TwinCAT 3.1. build 4024.24, the functions *FB_EcCoEReadBIC* and *FB_EcCoEReadBTN* for reading into the PLC are available in the *Tc2_EtherCAT* library from v3.3.19.0
- The following auxiliary functions are available for processing the BIC/BTN data in the PLC in *Tc2_Uilities* as of TwinCAT 3.1 build 4024.24
 - *F_SplitBIC*: The function splits the Beckhoff Identification Code (BIC) *sBICValue* into its components using known identifiers and returns the recognized substrings in the *ST_SplittedBIC* structure as a return value
 - *BIC_TO_BTN*: The function extracts the BTN from the BIC and returns it as a return value
- Note: If there is further electronic processing, the BTN is to be handled as a *string(8)*; the identifier "SBTN" is not part of the BTN.
- Technical background
 The new BIC information is written as an additional category in the ESI-EEPROM during device production. The structure of the ESI content is largely dictated by the ETG specifications, therefore the additional vendor-specific content is stored using a category in accordance with the ETG.2010. ID 03 tells all EtherCAT masters that they may not overwrite these data in the event of an update or restore the data after an ESI update.
 The structure follows the content of the BIC, see here. The EEPROM therefore requires approx. 50..200 bytes of memory.
- Special cases
 - If multiple hierarchically arranged ESCs are installed in a device, only the top-level ESC carries the eBIC information.
 - If multiple non-hierarchically arranged ESCs are installed in a device, all ESCs carry the eBIC information.
 - If the device consists of several sub-devices which each have their own identity, but only the top-level device is accessible via EtherCAT, the eBIC of the top-level device is located in the CoE object directory 0x10E2:01 and the eBICs of the sub-devices follow in 0x10E2:nn.

PROFIBUS; PROFINET, and DeviceNet devices

Currently, no electronic storage or readout is planned for these devices.

2 Product description

2.1 Introduction

The PROFINET IO controller (master) is a TwinCAT supplement that turns every Beckhoff PC-based control system into a PROFINET IO controller. By installing the supplement, a standard Ethernet interface becomes a PROFINET master. This supplement can be used on PCs and Embedded PCs.

PROFINET can be simply coupled with EtherCAT in connection with the EL663x PROFINET terminal for the EtherCAT I/O system, wherein the terminal represents a slave on the EtherCAT side but acts as a controller towards PROFINET. In this way any EtherCAT network can also exchange data with PROFINET IO devices.

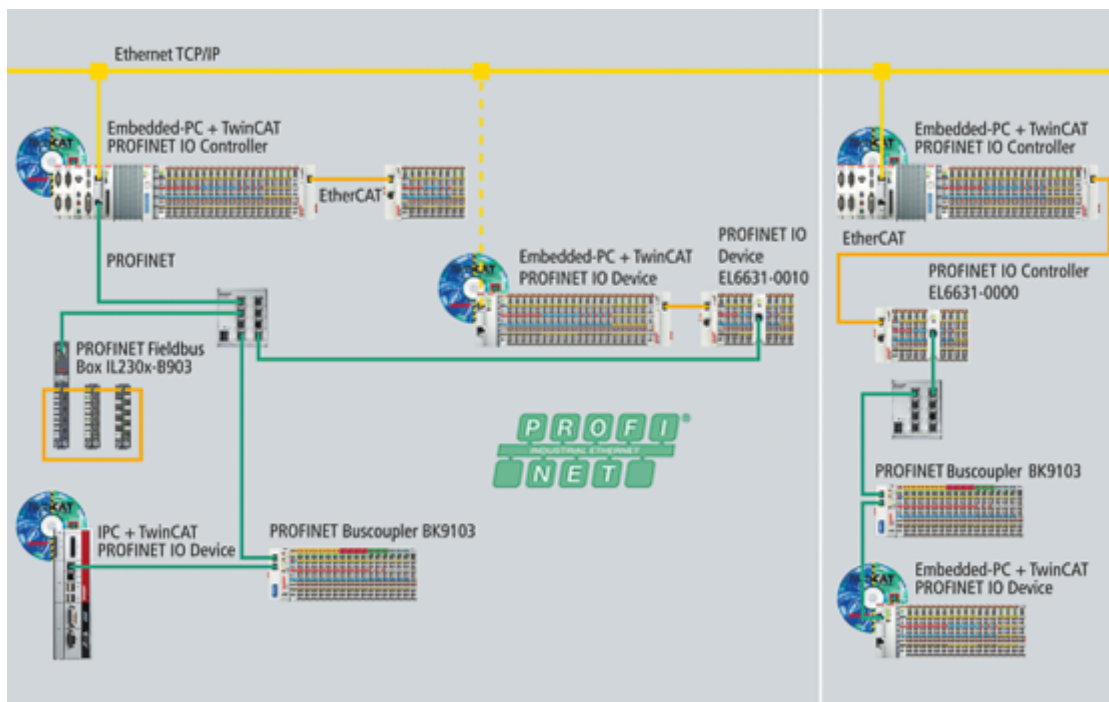

Fig. 4: PROFINET topology example

There are two kinds of PROFINET: PROFINET I/O and PROFINET CBA. TwinCAT supports PROFINET I/O.

In turn, 4 kinds of cyclic communication are defined within PROFINET I/O: RTClass1 to 3 and RToverUDP. The TwinCAT PROFINET I/O controller and the EL6631 presently support RTClass1, while the EL6632 can communicate over RTClass1 and RTClass3. All cycle times defined for RTClass1 are supported, from 1 ms in power-of-2 steps (1, 2, 4, 8, ... ms).

The smallest cycle time presently supported by the EL6632 is 500 μ s (for RTClass3).

2.2 Technical data

Technical data	PROFINET via RT Ethernet	PROFINET via EtherCAT (EL6632)	PROFINET via EtherCAT (EL6631)
Ethernet Hardware	Real-Time Ethernet Hardware	EL6632 PROFINET terminal	EL6631 PROFINET terminal
Operating system	Windows XP, XP Embedded (CE under preparation)		
Software	TwinCAT I/O, PLC, NC, NC I, CNC		
Target systems	PC (x86), Windows CE devices	PC (x86), Windows CE devices with EtherCAT interface	PC (x86), Windows CE devices with EtherCAT interface
Cycle time	min. 1 ms	min. 500 us	min. 1 ms
Number of possible IO devices	limited by CPU performance and memory	for IRT up to 5 devices, for RT up to 15 devices	Up to 15 devices

2.3 Activation of the PROFINET Controller Supplement

Requirement:

TwinCAT 2.11 Build 1545

Hardware: Ethernet card with Intel chipset

An Ethernet card with Intel chipset is required in order to use the PROFINET controller Supplement. Install the RT-Ethernet driver for this card ([TwinCAT Ethernet driver - Installation](#)). Once the installation of the driver has been completed you can create the PROFINET controller in the system manager and connect it to the hardware (Ethernet card).

The PROFINET controller can be scanned in Config mode (TwinCAT icon is blue) and values can be written in Freerun mode. The appropriate key must be entered in order to operate TwinCAT in Run mode. In order to obtain the registration key, send the MAC address of the Ethernet card you are using with the order. You will then receive the activation code.

MAC address

You can read the MAC address via the System Manager. To do this, append the PROFINET controller device.

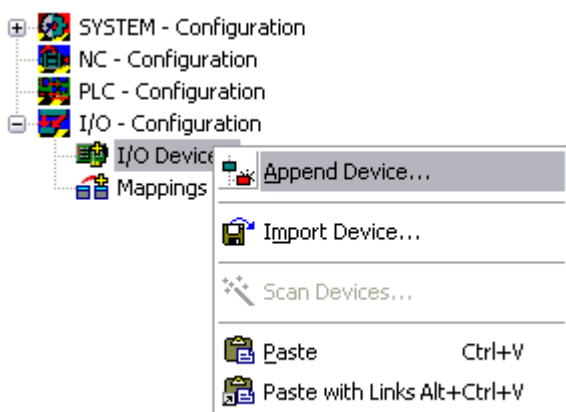

Fig. 5: "Append Device" context menu

Select the PROFINET I/O controller under PROFINET.

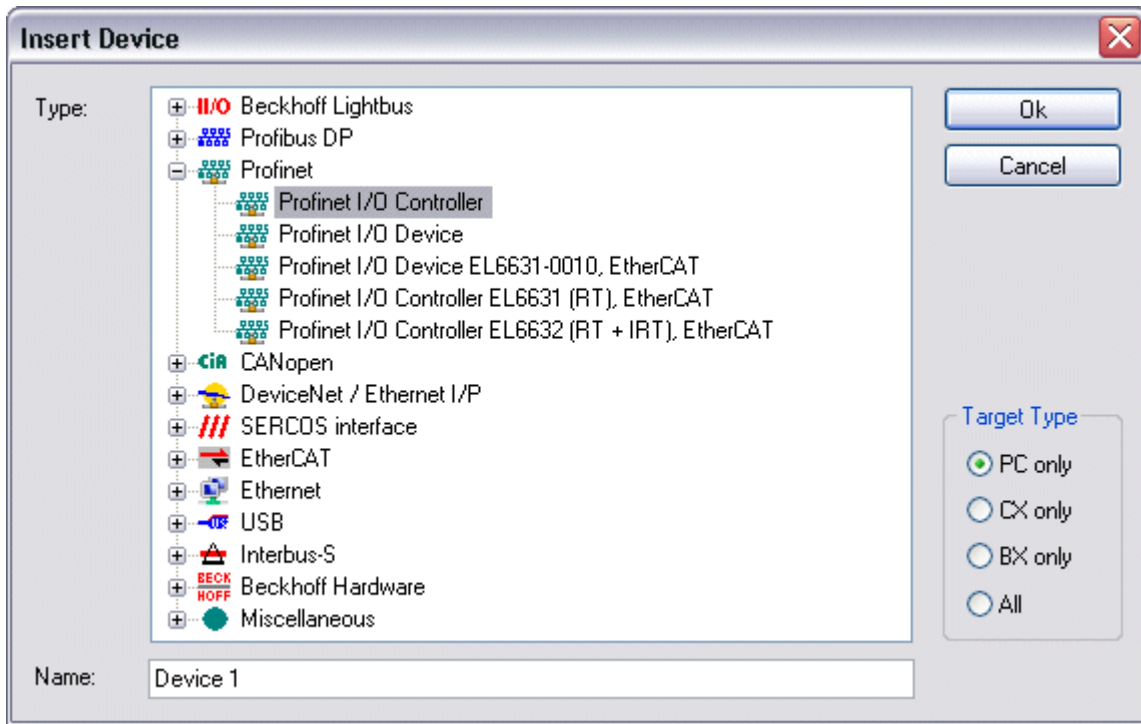

Fig. 6: PROFINET Controller/Device selection

Switch to Adapter and press the search button.

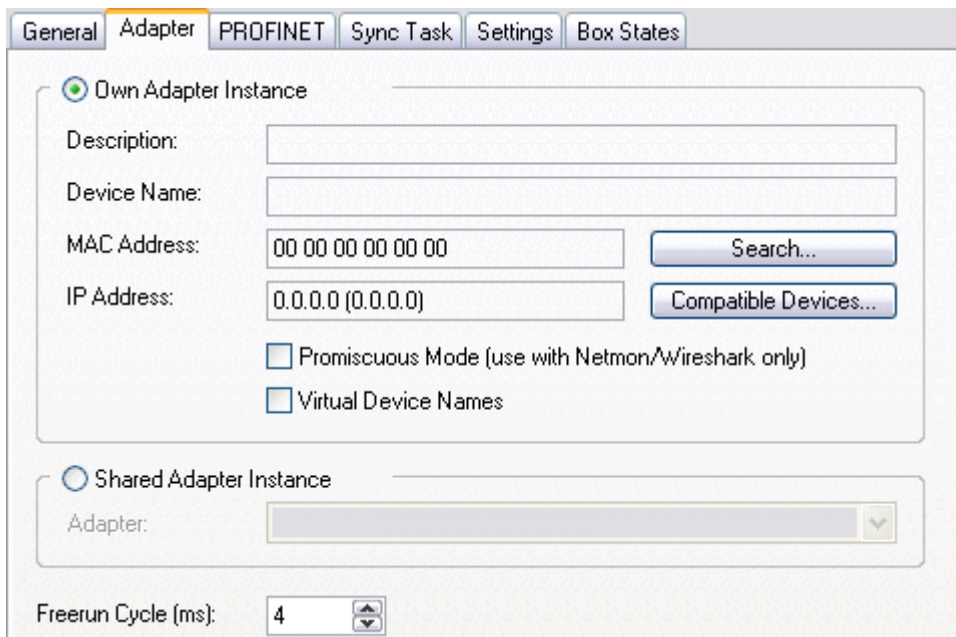

Fig. 7: "Adapter" tab, Search button

If the real-time driver has been installed correctly, you will be shown the corresponding cards. If no cards are available for selection, this means that the driver has not been correctly installed. Select the card to which your PROFINET devices are connected.

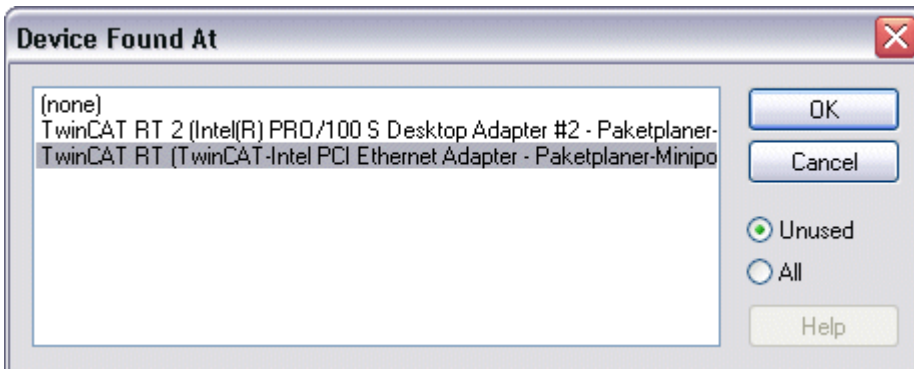

Fig. 8: TWINCAT network adapter selection

The MAC address of the card will be displayed under Adapter -> MAC address. This is now required for the key.

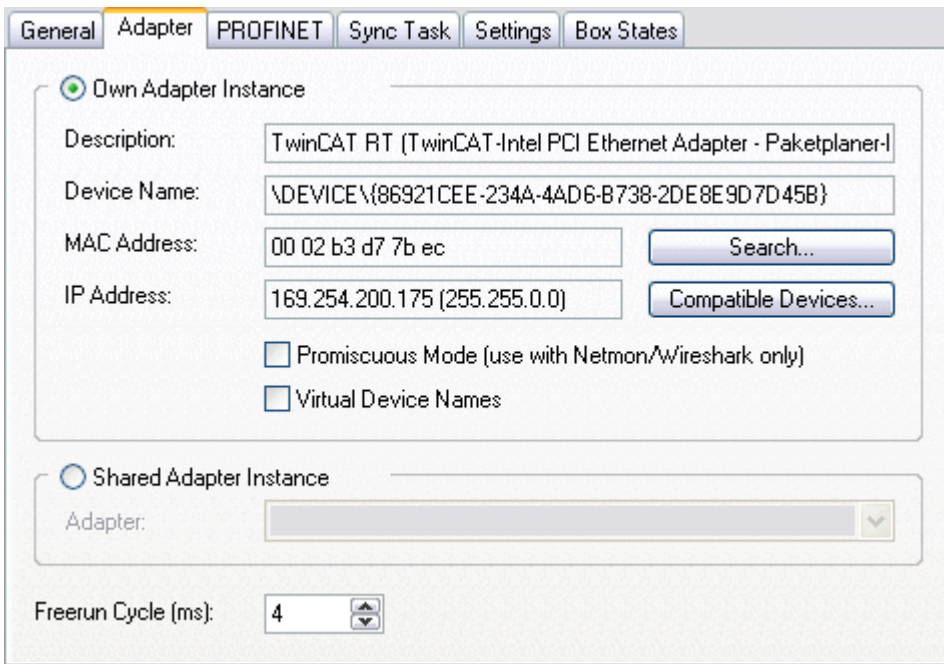

Fig. 9: Display of the MAC address

Switch to the PROFINET tab and press 'Insert key...'. Now enter the key.

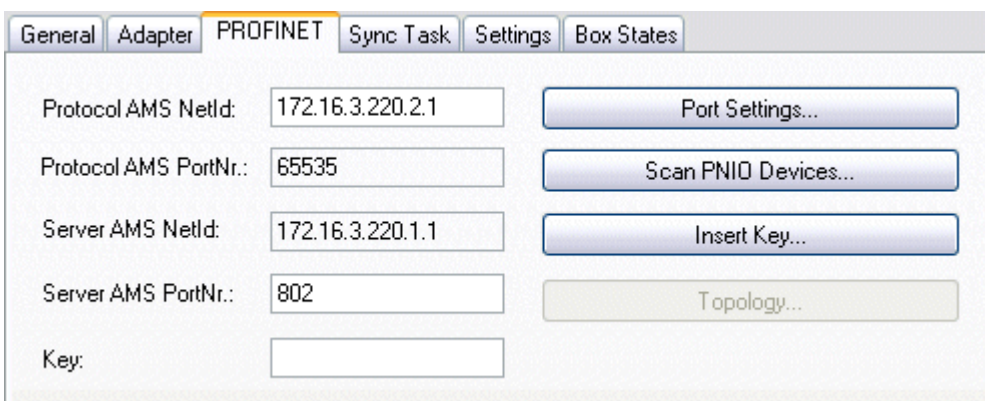
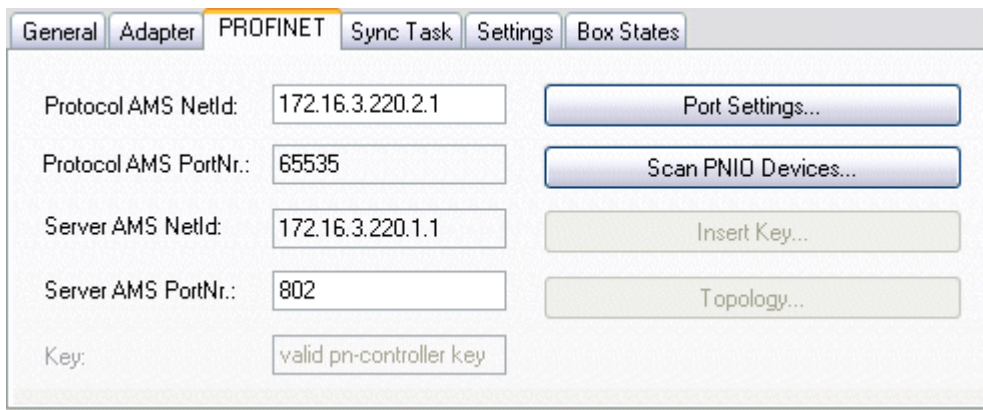

Fig. 10: Entry of the MAC address as the key via "Insert Key"

If the key is accepted the following appears in the Key field: *valid pn-controller key*.



The image shows a software configuration window with several tabs: General, Adapter, PROFINET (selected), Sync Task, Settings, and Box States. The PROFINET tab contains the following fields and buttons:

Protocol AMS NetId:	<input type="text" value="172.16.3.220.2.1"/>	<input type="button" value="Port Settings..."/>
Protocol AMS PortNr.:	<input type="text" value="65535"/>	<input type="button" value="Scan PNIO Devices..."/>
Server AMS NetId:	<input type="text" value="172.16.3.220.1.1"/>	<input type="button" value="Insert Key..."/>
Server AMS PortNr.:	<input type="text" value="802"/>	<input type="button" value="Topology..."/>
Key:	<input type="text" value="valid pn-controller key"/>	

Fig. 11: "PROFINET" tab, confirmation of the key

2.4 EL6631 - PROFINET-RT-Controller

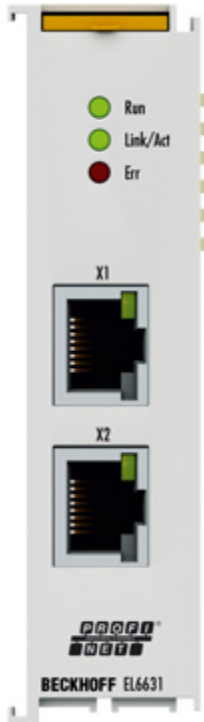

Fig. 12: EL6631 - PROFINET-RT-Controller

The EL6631 PROFINET IO Controller (Master) terminal supports the complete real-time function (RT) as well as extensive diagnostic possibilities. All services in accordance with Conformance Class B are supported.

Up to 15 PROFINET IO devices can be projected on the EL6631.

● Supplement



The TwinCAT Supplement is not required for the EL6631 and EL6632.

● TwinCAT Version



The released TwinCAT version is TwinCAT 2.11 R3.

It must be ensured that the target system also corresponds to the TwinCAT version. Older TwinCAT versions cannot be used!

2.5 EL6631 - Technical data

Technical data	EL6631
Technology	PROFINET IO
Number of ports/channels	2
Ethernet interface	100BASE-TX Ethernet with 2 x RJ 45
Fieldbus	PROFINET RT controller
Cable length	up to 100 m twisted pair
Hardware diagnostics	Status LEDs
Power supply	via the E-bus
Electrical isolation	500 V (E-Bus/Ethernet)
Max. number of RT-capable devices	15 (depending on the cycle time and number of data)
Minimum RT cycle	1 ms
Conformity class	B
Protocol	RT
Drivers	TwinCAT 2.11 R3
Maximum number of process data	1 kbyte input data and 1 kbyte output data
Configuration	via the EtherCAT master
Current consumption via E-bus	400 mA typ.
Special features	LLDP, SNMP, conformance class B, max. 15 RT users, min. 1 ms RT cycle
Mounting	on 35 mm mounting rail conforms to EN 60715 housing with traction lever unlocking [▶ 37] housing with front release [▶ 39]
Weight	approx. 75 g
Permissible ambient temperature at operation**)	0...+55 °C
Permissible ambient temperature for storage	-25...+85 °C
Permissible relative humidity	95 % no condensation
Vibration / shock resistance	conforms to EN 60068-2-6 / EN 60068-2-27
EMC immunity / emission	conforms to EN 61000-6-2 / EN 61000-6-4
Protection class	IP20
Installation position	Standard installation position (an operating temperature of 45°C applies to other installation positions), see also notice [▶ 34]
Approvals / markings*)	CE, EAC, UKCA cULus [▶ 32], ATEX [▶ 29], IECEX [▶ 30]

*) Real applicable approvals/markings see type plate on the side (product marking).

**) If there is another terminal with high power loss (e.g. E-bus current >250 mA) next to the terminal, an [EL9xx0](#) power feed or separation terminal must be connected in between (recommendation: terminal with E-bus ASIC).

Ex markings

Standard	Marking
ATEX	II 3 G Ex nA IIC T4 Gc
IECEX	Ex nA IIC T4 Gc

2.6 EL6631 - LEDs

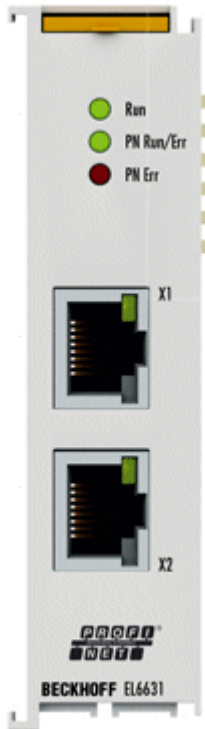

Fig. 13: EL6631 - LEDs

LEDs for EtherCAT diagnosis

LED	Display	Description
RUN	green	off
		flashing 200 ms
		off (1 s) on (200 ms)
		on
		State of the EtherCAT State Machine: INIT = initialization of the terminal; BOOTSTRAP = function for firmware updates of the terminal
		State of the EtherCAT State Machine: PREOP = function for mailbox communication and different standard-settings set
		State of the EtherCAT State Machine: SAFEOP = verification of the sync manager channels and the distributed clocks. Outputs remain in safe state
		State of the EtherCAT State Machine: OP = normal operating state; mailbox and process data communication is possible

LED diagnosis PROFINET RUN/Err

Color green	Color red	Meaning
off	flashing 200 ms	Terminal starts
flashing 200 ms	off	No name
1 s off, 200 ms on	off	No IP address
on	off	EL terminal is parameterized

LED diagnosis PROFINET Err

Colours green	Colours red	Meaning
off	flashing 500 ms	no AR established with any device
off	1 s off, 200 ms on	At least one device has not established an AR
1 s off, 200 ms on	off	At least one device has signaled an error, e.g. that there is a module difference or that the error bit for an IO-CR is set (Problem Indicator)
flashing 200 ms	off	At least one device is signaling that its status is 'Stop' (Provider State Stop)
on	off	All PROFINET devices are in data exchange mode

If there are several different errors, then the error that is located at the top of (or higher in) the table is always displayed.

LEDs starting up

Run	PN Run/Err	PN Err	Meaning
off	off	off	No electrical voltage connected to E-bus. The EL6631 must be exchanged if EtherCAT terminals behind it function.
off	off	red on	EL terminal is starting up; after approx. 10 seconds, the LED should go out. If this does not happen, the EL6631 module must be exchanged.

2.7 EL6632 - PROFINET-IRT-Controller

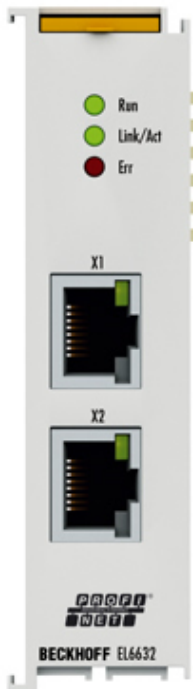

Fig. 14: EL6632 - PROFINET-IRT-Controller

The EL6632 PROFINET-IRT controller terminal offers the complete RT (real time) or IRT (isochronous real-time) functionality and a wide range of diagnostic options. All services in accordance with Conformance Class C are supported.

Depending on the cycle time, up to five PROFINET-IRT or up to 15 PROFINET RT devices can be operated at the EL6632 in a line topology.

● Supplement

i The TwinCAT Supplement is not required for the EL6631 and EL6632.

● TwinCAT Version

i The released TwinCAT version is TwinCAT 2.11 R3.
It must be ensured that the target system also corresponds to the TwinCAT version.
Older TwinCAT versions cannot be used!

2.8 EL6632 - Technical data

Technical data	EL6632
Technology	PROFINET IO
Number of ports/channels	2
Ethernet interface	100BASE-TX Ethernet with 2 x RJ 45
Fieldbus	PROFINET RT / IRT controller
Cable length	up to 100 m twisted pair
Hardware diagnostics	Status LEDs
Power supply	via the E-bus
Electrical isolation	500 V (E-Bus/Ethernet)
Max. number of IRT-capable devices	5 (depending on the cycle time and number of data)
Max. number of RT-capable devices	15 (depending on the cycle time and number of data)
Minimum IRT cycle	500 µs
Minimum RT cycle	1 ms
Conformity class	C
Protocol	RT or IRT
Drivers	TwinCAT 2.11 R3
Maximum number of process data	1 kbyte input data and 1 kbyte output data
Configuration	via the EtherCAT master
Current consumption via E-bus	400 mA typ.
Special features	Conformity class C, max. 5 IRT devices in series, max. 15 RT devices, min. 500 µs IRT cycle, min. 1 ms RT cycle
Dimensions (W x H x D)	approx. 26 mm x 100 mm x 52 mm (width aligned: 23 mm)
Mounting	on 35 mm mounting rail conforms to EN 60715 housing with traction lever unlocking [▶ 37] housing with front release [▶ 39]
Weight	approx. 75 g
Permissible ambient temperature at operation**)	0...+55 °C
Permissible ambient temperature for storage	-25...+85 °C
Permissible relative humidity	95 % no condensation
Vibration / shock resistance	conforms to EN 60068-2-6 / EN 60068-2-27
EMC immunity / emission	conforms to EN 61000-6-2 / EN 61000-6-4
Protection class	IP20
Installation position	Standard installation position (an operating temperature of 45°C applies to other installation positions), see also notice [▶ 34]
Approvals / markings*)	CE, UKCA, EAC cULus [▶ 32], ATEX [▶ 29], IECEx [▶ 30]

*) Real applicable approvals/markings see type plate on the side (product marking).

***) If there is another terminal with high power loss (e.g. E-bus current >250 mA) next to the terminal, an [EL9xx0](#) power feed or separation terminal must be connected in between (recommendation: terminal with E-bus ASIC).

Ex markings

Standard	Marking
ATEX	II 3 G Ex nA IIC T4 Gc
IECEX	Ex nA IIC T4 Gc

3 Mounting and wiring

3.1 Instructions for ESD protection

NOTICE

Destruction of the devices by electrostatic discharge possible!

The devices contain components at risk from electrostatic discharge caused by improper handling.

- When handling the components, ensure that there is no electrostatic discharge; also avoid touching the spring contacts directly (see illustration).
- Contact with highly insulating materials (synthetic fibers, plastic films, etc.) should be avoided when handling components at the same time.
- When handling the components, ensure that the environment (workplace, packaging and persons) is properly earthed.
- Each bus station must be terminated on the right-hand side with the [EL9011](#) or [EL9012](#) end cap to ensure the degree of protection and ESD protection.

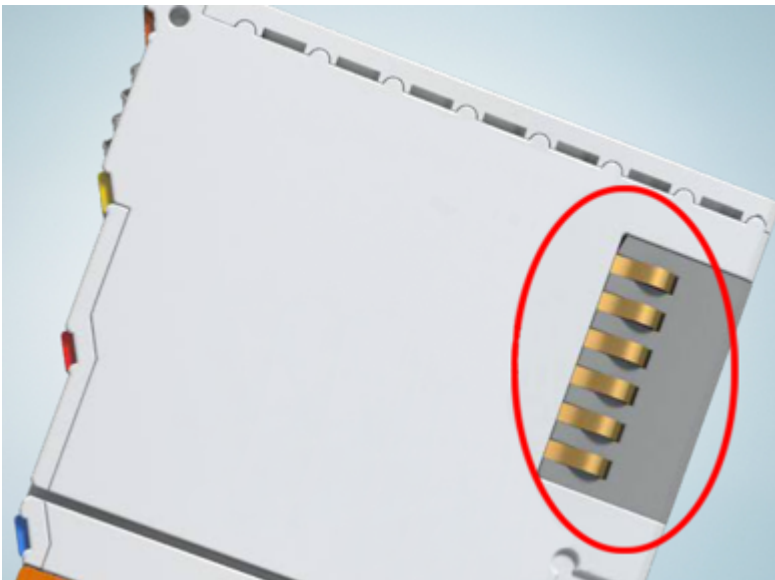

Fig. 15: Spring contacts of the Beckhoff I/O components

3.2 Explosion protection

3.2.1 ATEX - Special conditions (standard temperature range)

⚠ WARNING

Observe the special conditions for the intended use of Beckhoff fieldbus components with standard temperature range in potentially explosive areas (directive 2014/34/EU)!

- The certified components are to be installed in a suitable housing that guarantees a protection class of at least IP54 in accordance with EN 60079-15! The environmental conditions during use are thereby to be taken into account!
- For dust (only the fieldbus components of certificate no. KEMA 10ATEX0075 X Issue 9): The equipment shall be installed in a suitable enclosure providing a degree of protection of IP54 according to EN 60079-31 for group IIIA or IIIB and IP6X for group IIIC, taking into account the environmental conditions under which the equipment is used!
- If the temperatures during rated operation are higher than 70°C at the feed-in points of cables, lines or pipes, or higher than 80°C at the wire branching points, then cables must be selected whose temperature data correspond to the actual measured temperature values!
- Observe the permissible ambient temperature range of 0 to 55°C for the use of Beckhoff fieldbus components standard temperature range in potentially explosive areas!
- Measures must be taken to protect against the rated operating voltage being exceeded by more than 40% due to short-term interference voltages!
- The individual terminals may only be unplugged or removed from the Bus Terminal system if the supply voltage has been switched off or if a non-explosive atmosphere is ensured!
- The connections of the certified components may only be connected or disconnected if the supply voltage has been switched off or if a non-explosive atmosphere is ensured!
- The fuses of the KL92xx/EL92xx power feed terminals may only be exchanged if the supply voltage has been switched off or if a non-explosive atmosphere is ensured!
- Address selectors and ID switches may only be adjusted if the supply voltage has been switched off or if a non-explosive atmosphere is ensured!

Standards

The fundamental health and safety requirements are fulfilled by compliance with the following standards:

- EN 60079-0:2012+A11:2013
- EN 60079-15:2010
- EN 60079-31:2013 (only for certificate no. KEMA 10ATEX0075 X Issue 9)

Marking

The Beckhoff fieldbus components with standard temperature range certified according to the ATEX directive for potentially explosive areas bear one of the following markings:



II 3G KEMA 10ATEX0075 X Ex nA IIC T4 Gc Ta: 0 ... +55°C

II 3D KEMA 10ATEX0075 X Ex tc IIIC T135°C Dc Ta: 0 ... +55°C
(only for fieldbus components of certificate no. KEMA 10ATEX0075 X Issue 9)

or



II 3G KEMA 10ATEX0075 X Ex nA nC IIC T4 Gc Ta: 0 ... +55°C

II 3D KEMA 10ATEX0075 X Ex tc IIIC T135°C Dc Ta: 0 ... +55°C
(only for fieldbus components of certificate no. KEMA 10ATEX0075 X Issue 9)

3.2.2 IECEx - Special conditions

WARNING

Observe the special conditions for the intended use of Beckhoff fieldbus components in potentially explosive areas!

- For gas: The equipment shall be installed in a suitable enclosure providing a degree of protection of IP54 according to IEC 60079-15, taking into account the environmental conditions under which the equipment is used!
- For dust (only the fieldbus components of certificate no. IECEx DEK 16.0078X Issue 3):
The equipment shall be installed in a suitable enclosure providing a degree of protection of IP54 according to EN 60079-31 for group IIIA or IIIB and IP6X for group IIIC, taking into account the environmental conditions under which the equipment is used!
- The equipment shall only be used in an area of at least pollution degree 2, as defined in IEC 60664-1!
- Provisions shall be made to prevent the rated voltage from being exceeded by transient disturbances of more than 119 V!
- If the temperatures during rated operation are higher than 70°C at the feed-in points of cables, lines or pipes, or higher than 80°C at the wire branching points, then cables must be selected whose temperature data correspond to the actual measured temperature values!
- Observe the permissible ambient temperature range for the use of Beckhoff fieldbus components in potentially explosive areas!
- The individual terminals may only be unplugged or removed from the Bus Terminal system if the supply voltage has been switched off or if a non-explosive atmosphere is ensured!
- The connections of the certified components may only be connected or disconnected if the supply voltage has been switched off or if a non-explosive atmosphere is ensured!
- Address selectors and ID switches may only be adjusted if the supply voltage has been switched off or if a non-explosive atmosphere is ensured!
- The front hatch of certified units may only be opened if the supply voltage has been switched off or a non-explosive atmosphere is ensured!

Standards

The fundamental health and safety requirements are fulfilled by compliance with the following standards:

- EN 60079-0:2011
- EN 60079-15:2010
- EN 60079-31:2013 (only for certificate no. IECEx DEK 16.0078X Issue 3)

Marking

Beckhoff fieldbus components that are certified in accordance with IECEx for use in areas subject to an explosion hazard bear the following markings:

Marking for fieldbus components of certificate no. IECEx DEK 16.0078X Issue 3:	IECEx DEK 16.0078 X Ex nA IIC T4 Gc Ex tc IIIC T135°C Dc
--	---

Marking for fieldbus components of certificates with later issues:	IECEx DEK 16.0078 X Ex nA IIC T4 Gc
--	--

3.2.3 Continulative documentation for ATEX and IECEx

NOTICE



Continulative documentation about explosion protection according to ATEX and IECEx



Pay also attention to the continuative documentation

Ex. Protection for Terminal Systems

Notes on the use of the Beckhoff terminal systems in hazardous areas according to ATEX and IECEx,

that is available for [download](#) within the download area of your product on the Beckhoff homepage www.beckhoff.com!

3.3 UL notice

⚠ CAUTION	
	<p>Application</p> <p>Beckhoff EtherCAT modules are intended for use with Beckhoff's UL Listed EtherCAT System only.</p>
⚠ CAUTION	
	<p>Examination</p> <p>For cULus examination, the Beckhoff I/O System has only been investigated for risk of fire and electrical shock (in accordance with UL508 and CSA C22.2 No. 142).</p>
⚠ CAUTION	
	<p>For devices with Ethernet connectors</p> <p>Not for connection to telecommunication circuits.</p>

Basic principles

UL certification according to UL508. Devices with this kind of certification are marked by this sign:



3.4 Note - power supply

⚠ WARNING**Power supply from SELV / PELV power supply unit!**

SELV / PELV circuits (safety extra-low voltage / protective extra-low voltage) according to IEC 61010-2-201 must be used to supply this device.

Notes:

- SELV / PELV circuits may give rise to further requirements from standards such as IEC 60204-1 et al, for example with regard to cable spacing and insulation.
- A SELV supply provides safe electrical isolation and limitation of the voltage without a connection to the protective conductor, a PELV supply also requires a safe connection to the protective conductor.

3.5 Installation positions

NOTICE

Constraints regarding installation position and operating temperature range

Please refer to the technical data for a terminal to ascertain whether any restrictions regarding the installation position and/or the operating temperature range have been specified. When installing high power dissipation terminals ensure that an adequate spacing is maintained between other components above and below the terminal in order to guarantee adequate ventilation!

Optimum installation position (standard)

The optimum installation position requires the mounting rail to be installed horizontally and the connection surfaces of the EL- / KL terminals to face forward (see Fig. "Recommended distances for standard installation position"). The terminals are ventilated from below, which enables optimum cooling of the electronics through convection. "From below" is relative to the acceleration of gravity.

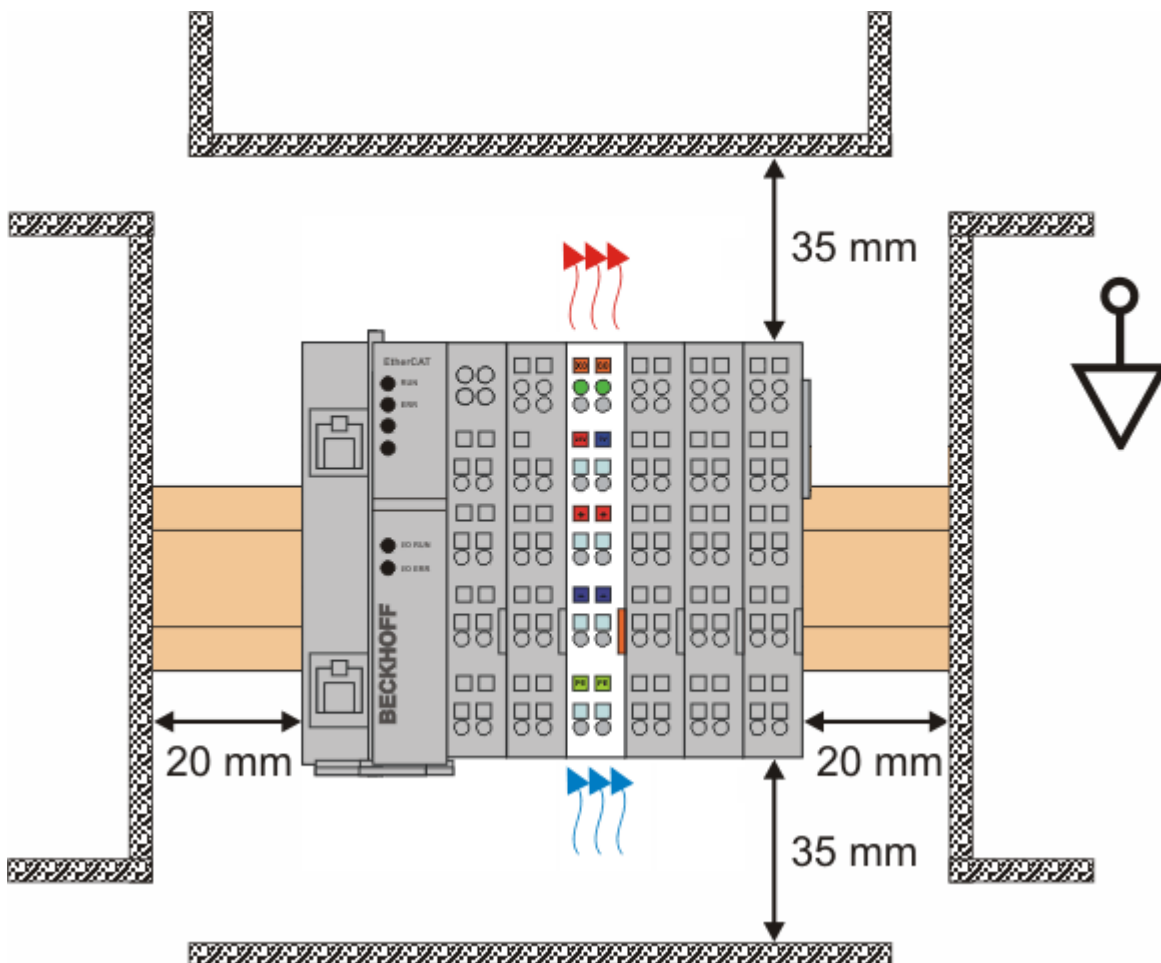

Fig. 16: Recommended distances for standard installation position

Compliance with the distances shown in Fig. "Recommended distances for standard installation position" is recommended.

Other installation positions

All other installation positions are characterized by different spatial arrangement of the mounting rail - see Fig "Other installation positions".

The minimum distances to ambient specified above also apply to these installation positions.

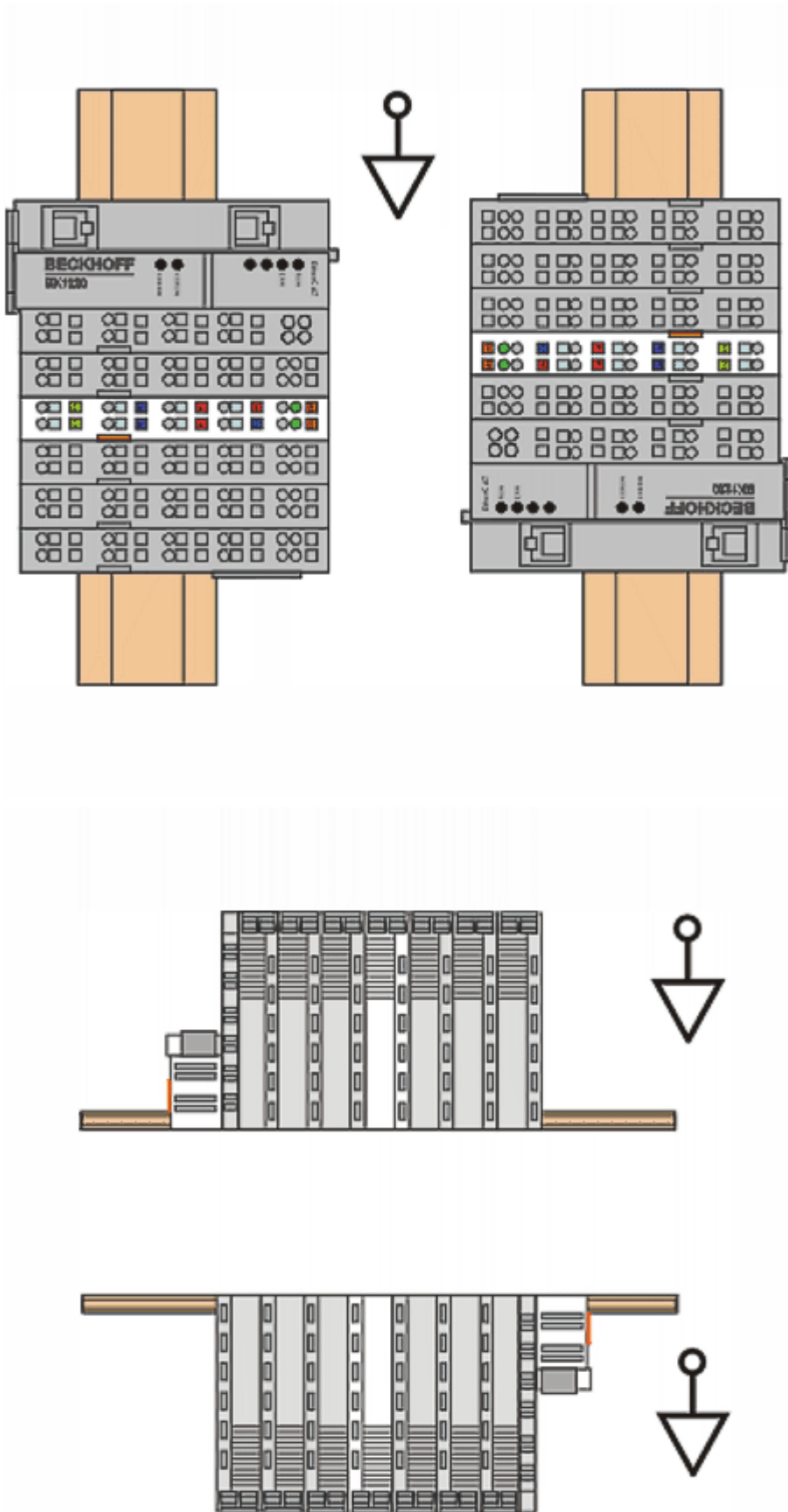

Fig. 17: Other installation positions

3.6 Note on shielding

NOTICE

Low-resistance shielding through external shield connection

The shielding of the EL66xx is capacitively connected to the mounting rail.

If low-resistance shielding is desired or required, the shield must be connected to an external shield support (e.g. with the clamp strap for shield connection [ZB5800](#)).

3.7 Mounting and demounting - traction lever unlocking

The terminal modules are fastened to the assembly surface with the aid of a 35 mm mounting rail (e. g. mounting rail TH 35-15).

i **Fixing of mounting rails**

The locking mechanism of the terminals and couplers extends to the profile of the mounting rail. At the installation, the locking mechanism of the components must not come into conflict with the fixing bolts of the mounting rail. To mount the recommended mounting rails under the terminals and couplers, you should use flat mounting connections (e.g. countersunk screws or blind rivets).

⚠ WARNING

Risk of electric shock and damage of device!

Bring the bus terminal system into a safe, powered down state before starting installation, disassembly or wiring of the Bus Terminals!

Mounting

- Fit the mounting rail to the planned assembly location.

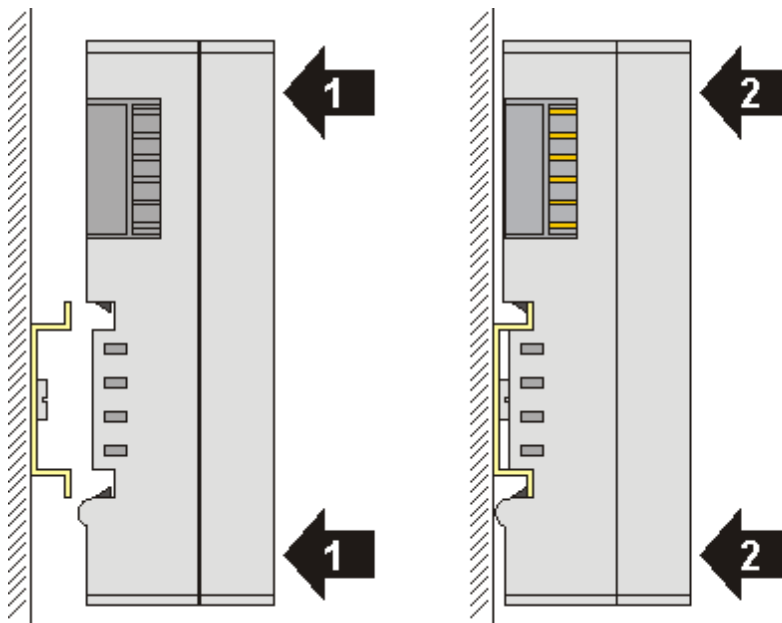

and press (1) the terminal module against the mounting rail until it latches in place on the mounting rail (2).

- Attach the cables.

Demounting

- Remove all the cables. Thanks to the KM/EM connector, it is not necessary to remove all the cables separately for this, but for each KM/EM connector simply undo 2 screws so that you can pull them off (fixed wiring)!
- Lever the unlatching hook on the left-hand side of the terminal module upwards with a screwdriver (3). As you do this
 - an internal mechanism pulls the two latching lugs (3a) from the top hat rail back into the terminal module,
 - the unlatching hook moves forwards (3b) and engages

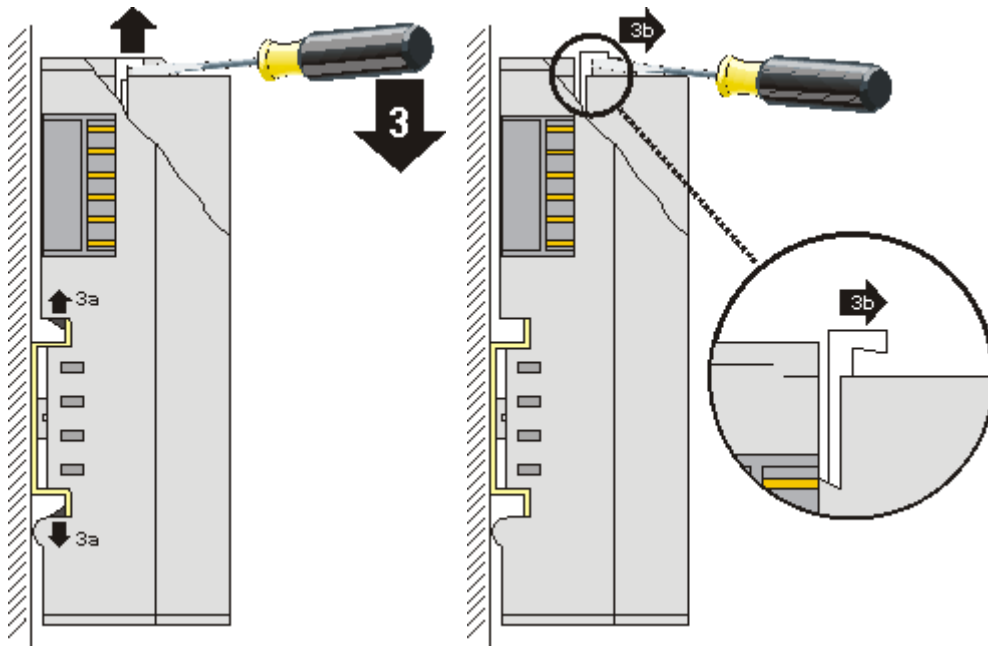

- In the case 32 and 64 channel terminal modules (KMxxx4 and KMxxx8 or EMxxx4 and EMxxx8) you now lever the second unlatching hook on the right-hand side of the terminal module upwards in the same way.
- Pull (4) the terminal module away from the mounting surface.

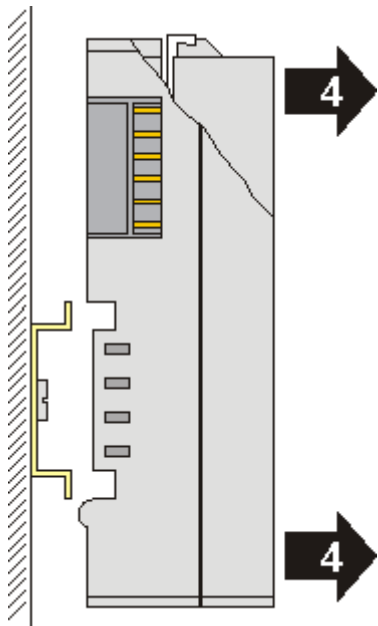

3.8 Mounting and demounting - top front unlocking

The terminal modules are fastened to the assembly surface with the aid of a 35 mm mounting rail (e. g. mounting rail TH 35-15).

i **Fixing of mounting rails**

The locking mechanism of the terminals and couplers extends to the profile of the mounting rail. At the installation, the locking mechanism of the components must not come into conflict with the fixing bolts of the mounting rail. To mount the recommended mounting rails under the terminals and couplers, you should use flat mounting connections (e.g. countersunk screws or blind rivets).

⚠ WARNING

Risk of electric shock and damage of device!

Bring the bus terminal system into a safe, powered down state before starting installation, disassembly or wiring of the Bus Terminals!

Mounting

- Fit the mounting rail to the planned assembly location.

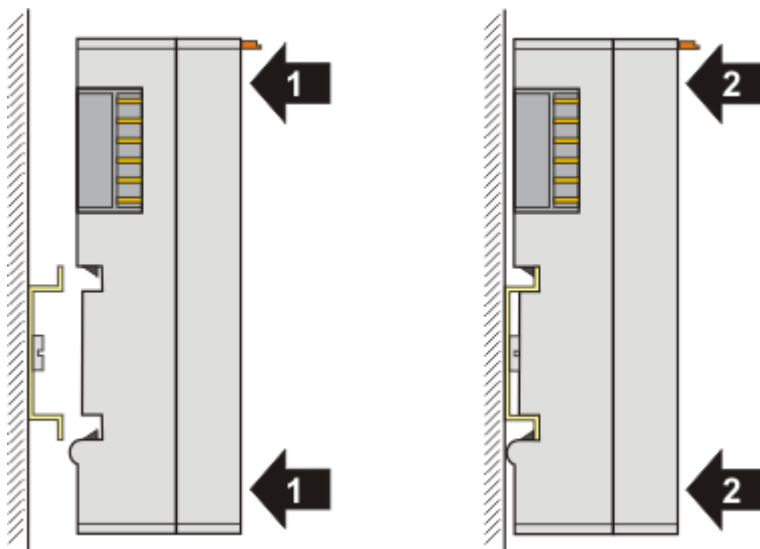

and press (1) the terminal module against the mounting rail until it latches in place on the mounting rail (2).

- Attach the cables.

Demounting

- Remove all the cables.
- Lever the unlatching hook back with thumb and forefinger (3). An internal mechanism pulls the two latching lugs (3a) from the top hat rail back into the terminal module.

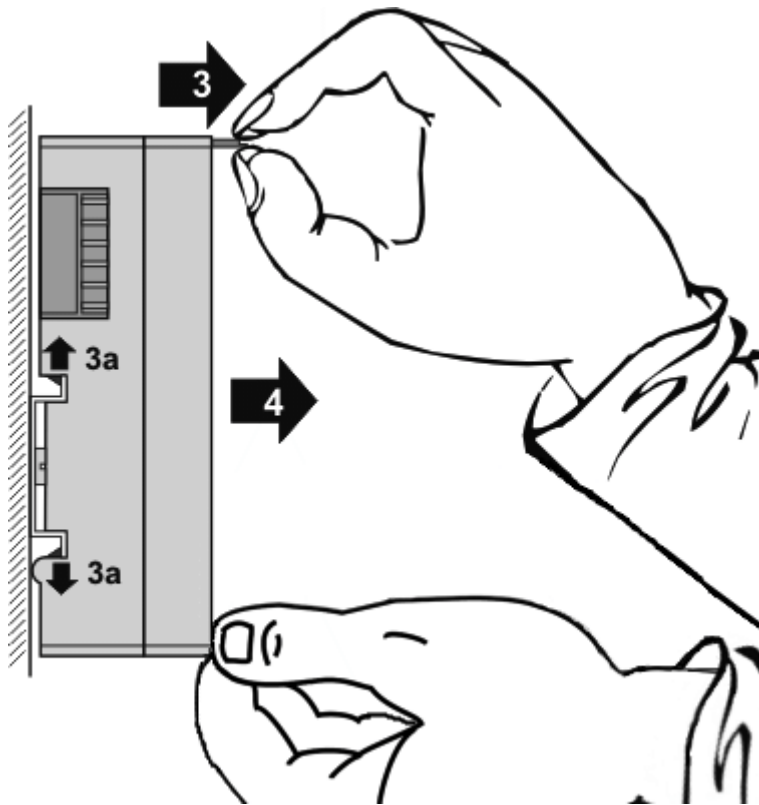

- Pull (4) the terminal module away from the mounting surface. Avoid canting of the module; you should stabilize the module with the other hand, if required.

3.9 Disposal



Products marked with a crossed-out wheeled bin shall not be discarded with the normal waste stream. The device is considered as waste electrical and electronic equipment. The national regulations for the disposal of waste electrical and electronic equipment must be observed.

4 PN controller protocol

4.1 Integration of the TwinCAT PROFINET controller protocol via a RealTimeEthernet interface

The controller protocol is appended directly to the I/O device. The available network interfaces are directly displayed when appending and are now available for selection.

If these are to be modified or checked afterwards, this can take place on the 'Adapter' tab.

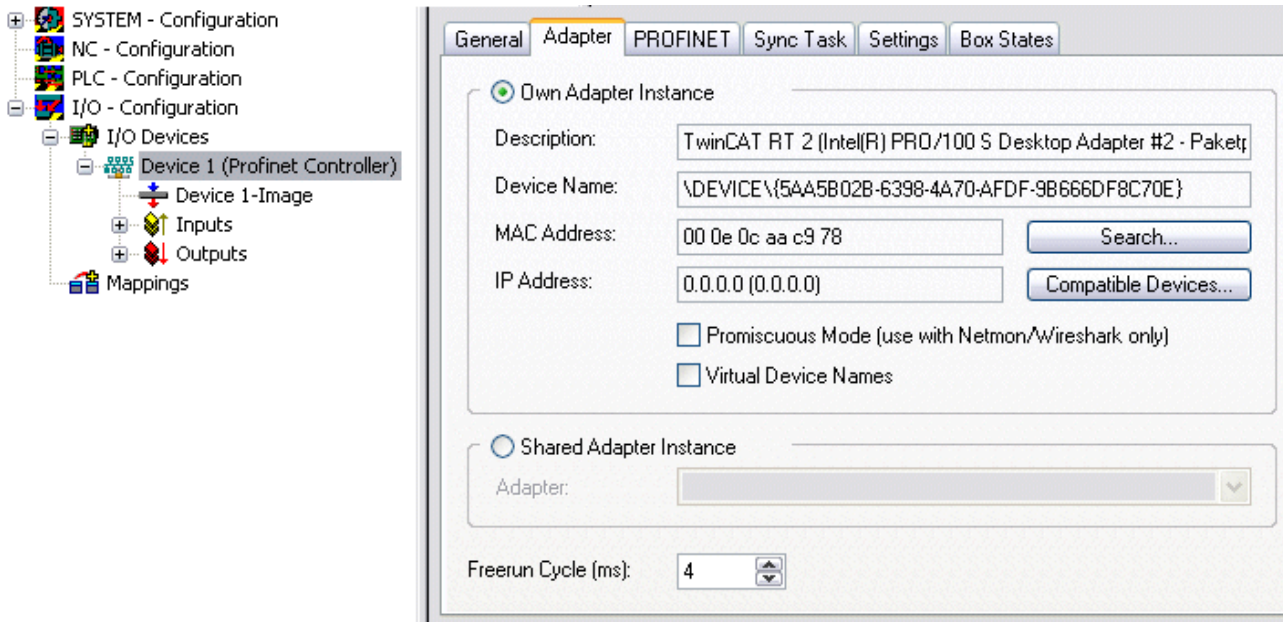

Fig. 18: "Adapter" tab

4.2 Integration of the TwinCAT PROFINET controller protocol via an EL663x interface

The controller protocol is appended directly to the I/O device. The respective protocol must be selected according to the terminal that is to be used (EL6631 or EL6632). If such a terminal is present in the projected EtherCAT strand, the associated adaptor is directly displayed when appending the protocol. If there are several terminals the corresponding one can be selected.

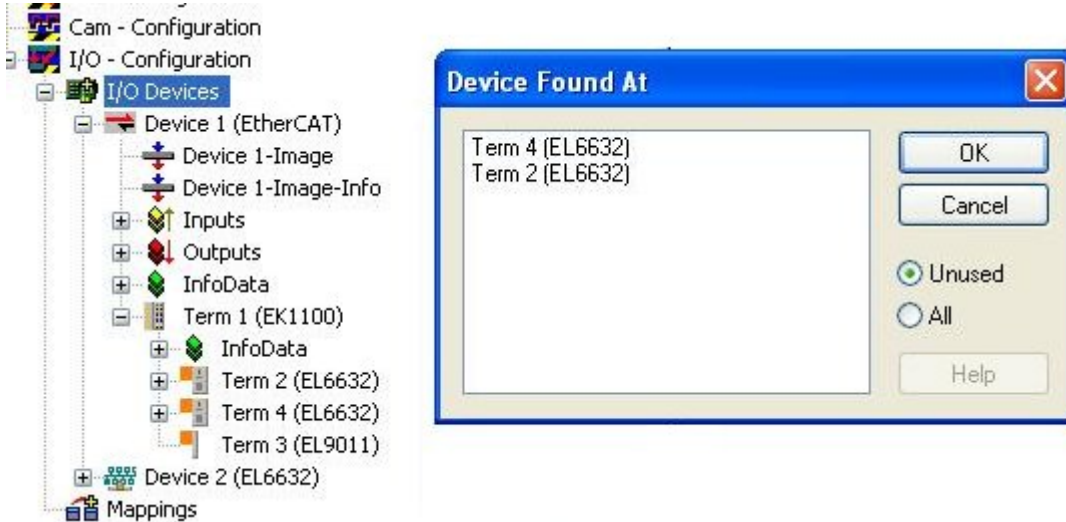

Fig. 19: Selection of the terminal for integrating the protocol

For the operation of several EL663x terminals the corresponding PROFINET protocol must be appended several times. If the terminal assignment is to be modified or checked afterwards, this can take place on the "Adapter" tab.

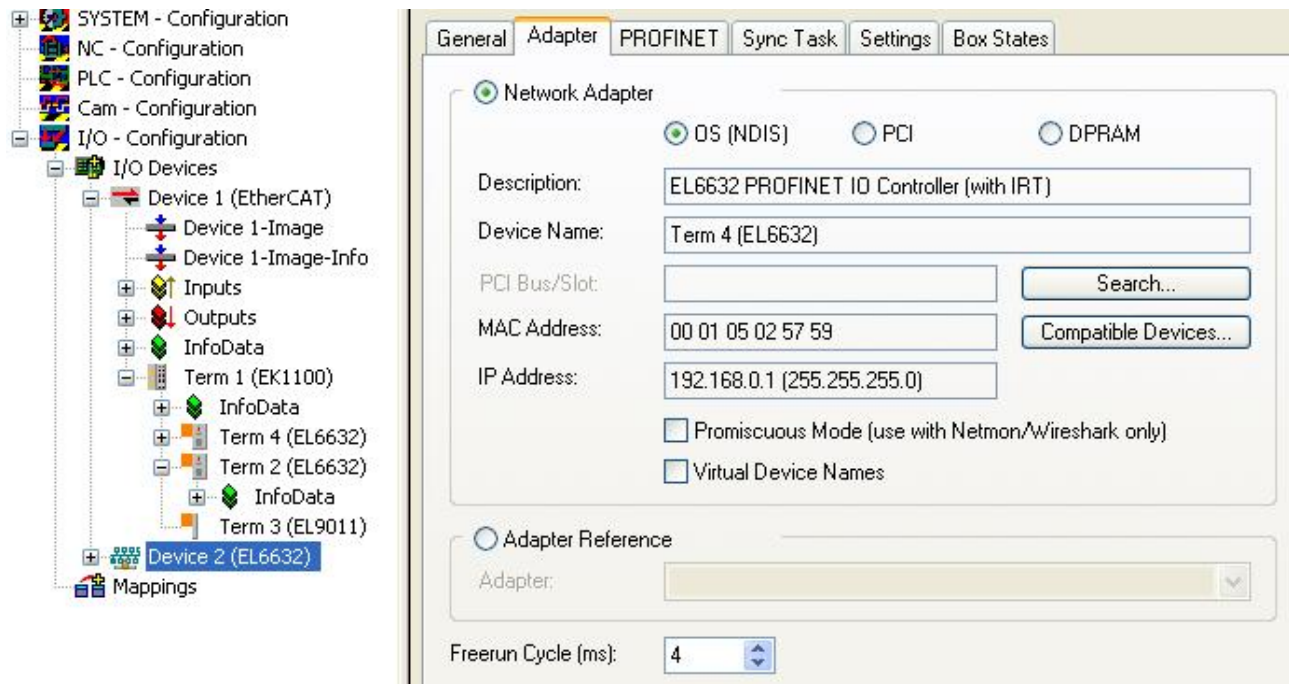

Fig. 20: "Adapter" tab, changing the terminal assignment

4.3 Settings / diagnostics

4.3.1 PROFINET

4.3.1.1 AMS Settings

Protocol AMS NetID text field

This is the NetID via which the PROFINET controller protocol can be reached via AMS.

Protocol AMS PortNo text field

This is the PortNo via which the PROFINET controller protocol can be reached via AMS. This is always fixed to 0xFFFF.

Server AMS NetID text field

This is the NetID to which certain AMS messages (e.g. PN records within the index range 0x1000 - 0x1FFF) are forwarded by the PROFINET driver. Currently this is always the SystemNetId.

Server AMS PortNo text field

This is the PortNo to which certain AMS messages (e.g. PN records within the index range 0x1000 - 0x1FFF) are forwarded by the PROFINET driver. By default this is the PLC Port 802 of runtime system 1.

4.3.1.2 PROFINET Key

Key text field

The key to enable the PROFINET controller protocol can be entered here. If a valid key has already been entered, a corresponding message appears in the window and no further entry can be made.

Button Insert Key...

The entered key is confirmed here. The key is thereby checked to ascertain whether or not it is valid. If not, a corresponding message appears. This button is inactive if a valid key has already been entered.

4.3.1.3 Button Port settings

This feature is presently only enabled for the real-time Ethernet protocol (no EL663x). With this a second PROFINET port and an intelligent switch can thus be realized with a second network card (Intel chipset) . It is intended to repeat this feature x times; however, it is presently limited to one additional port.

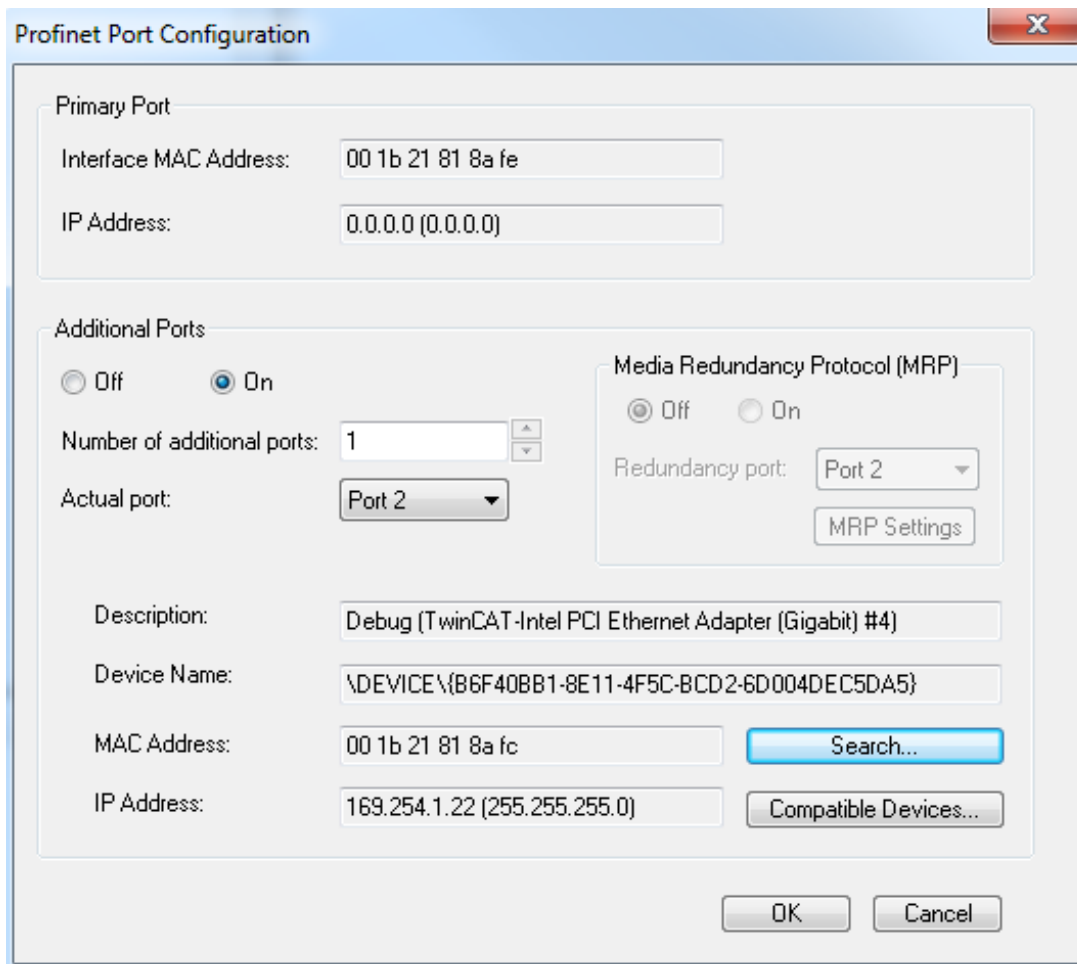

Fig. 21: "PROFINET Port configuration" dialog

In future it will be possible to enable the MRP (Media Redundancy Protocol) function via this menu; various settings can be made for this.

4.3.1.4 Button Scan PNIO Devices

This feature is comparable with the 'ScanBoxes' feature which, however, is available only in CONFIG mode . After successful scanning the following dialogue opens (if devices were found).

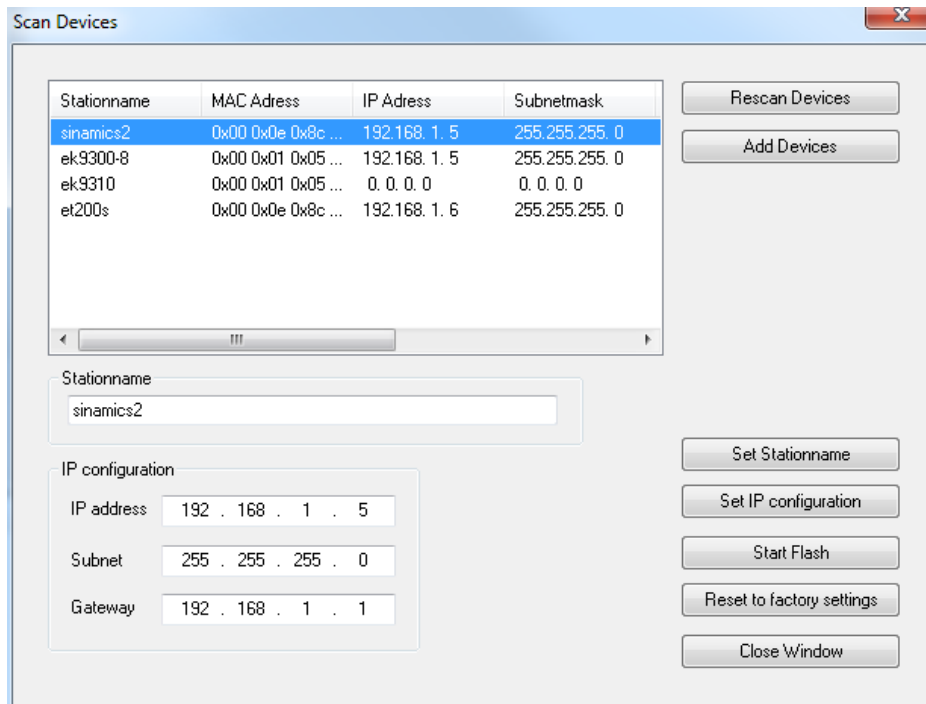

Fig. 22: Dialog „Scan Devices“

Various settings or project planning can be carried out for the devices here. These are adopted only when the corresponding button is explicitly pressed. When setting the name, care must be taken that only PROFINET-compliant characters are used. This also applies to the IP address; only valid combinations of IP and subnet are to be used. Name and IP are checked for correctness when setting PROFINET devices. DCP_SET is acknowledged with an error if this is not the case. Changes that have been made can be read back by pressing the Rescan button.

In addition the selected device can be signaled. This functionality is PROFINET-specific, but the method by which the signaling takes place is vendor-specific. As standard, however, the signal must arrive with a frequency of 2 Hz.

For example, the Beckhoff BK9103 Bus Coupler signals itself by the alternate flashing of two LEDs at a rate of 2 Hz. This function is very helpful for identifying the devices in this list. The flashing is stopped again by pressing the button once more. The flashing is stopped by closing the 'Scan Devices' window.

Subsequently, one or more devices can be marked with the Ctrl button. The selected device is adopted into the project by pressing 'Add Devices'.

i GSDML devices

The associated GSDML devices must be located in the '..\TwinCAT\Io\ProfiNet' (TC2) or '..\TwinCAT\3.1\Config\Io\Profinet' (TC3) folder!

Upon pressing 'Add Devices', the following question box opens:

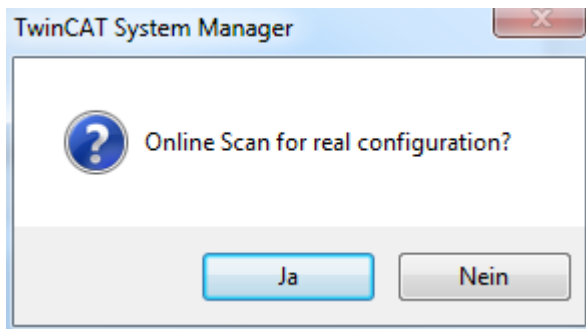

Fig. 23: Confirmation "Add Devices"

'Yes' button:

An attempt is initially made to determine the ModuleIdNumber of the DAP (Device Access Point) by an implicit read access. If this fails a corresponding dialog opens containing the possible DAPs, which must then be selected manually.

If all boxes have been appended, a 'Reload Devices' automatically takes place, i.e. the devices (adaptors) created are transmitted to the PROFINET driver. Subsequently, a distinction is made as to whether the box is a normal device or a drive with Profidrive support.

If the device is a normal device, the real module equipment (RealIdentificationData) is read out again by an implicit read access. If it is a Profidrive device, conversely, the required information is read out by a Profidrive access. A supervisor AR is established for this, within which the required write accesses can take place. The Submodule interface on the DAP is taken here as the Parameter Access Point. The parameter access takes place via data record 47, much like the case of the Profibus beforehand. When using Sinamics, however, it must be noted that such an access is only permitted from version 4.3 SP2. If an older version is used, a corresponding error message appears and the paramétrisation must take place manually.

Once the automatic module paramétrisation has been completed, a question box appears asking whether the port data should be read in automatically. Here again, the port connection for the individual devices is read out via an implicit read access.

The real port connection must be known for the various services. These may be simply diagnostic services, but the port connection is also required for the automatic device start (via alias) or for the creation of the IRT planning.

If this dialogue is acknowledged with 'no' or if the read access has failed, such a connection can also be made manually at the individual ports in the TwinCAT project.

If the port connection has been successfully generated, a query also appears in the case of an IRT controller (e.g. project planning on an EL6632) asking whether all devices are to be automatically connected in IRT Mode (RTClass3) (provided they support it).

If this is affirmed the cable length is additionally set to 10 m copper cable on all projected ports. The IRT algorithm requires this information for the calculation of the signal propagation delays. The precise cable length is not so important here (approx. +/-10 m), because the propagation delays tend to be small at 100 Mbit/s (5 ns/m). If the automatic switchover is not to take place immediately, these points can also be modified later either on the protocol or on the individual devices (on the interface or port submodule).

'No' button:

For each device a check is performed to ascertain whether the GSDML is present in the respective folder ('..\TwinCAT\Io\ProfiNet'). If this is the case, the list of possible DAPs is read in. Subsequently a selection dialogue is opened so that the corresponding DAP can be selected.

Once the devices have been appended in the project, the API below the Box can be accessed and the modules and submodules can be manually appended via it.

4.3.1.5 Button Topology

The offline topology can be compared with the online topology via this dialogue.

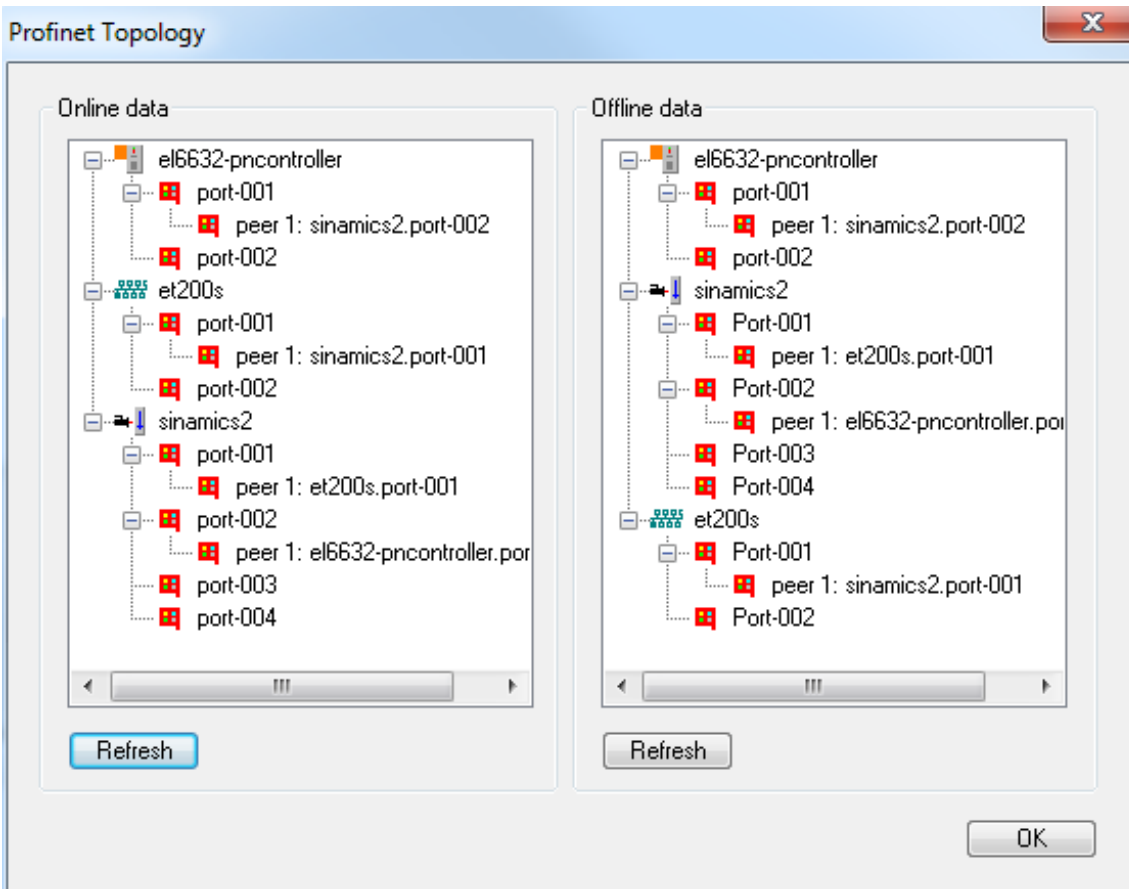

Fig. 24: "PROFINET Topology" dialog

It is quite possible for a device to have several partners on a port in the online view. This is the case, for example, if a switch is used in PROFINET that does not support LLDP (protocol for neighborhood ID).

In the offline view, on the other hand, partners may have been assigned that don't exist in the project. This takes place if the reading of the port properties was activated during automatic scanning and appending. In this case the device has a 'neighbor' that is adopted into the project, but the associated device box is missing from the *.tsm file. On activating this project the 'neighbor' which does not exist in the .tsm file is ignored in the driver.

4.3.1.6 Button IRT Config

This menu is enabled only for an IRT-capable controller (at present only EL6632). A global setting can be made for all projected devices via this menu.

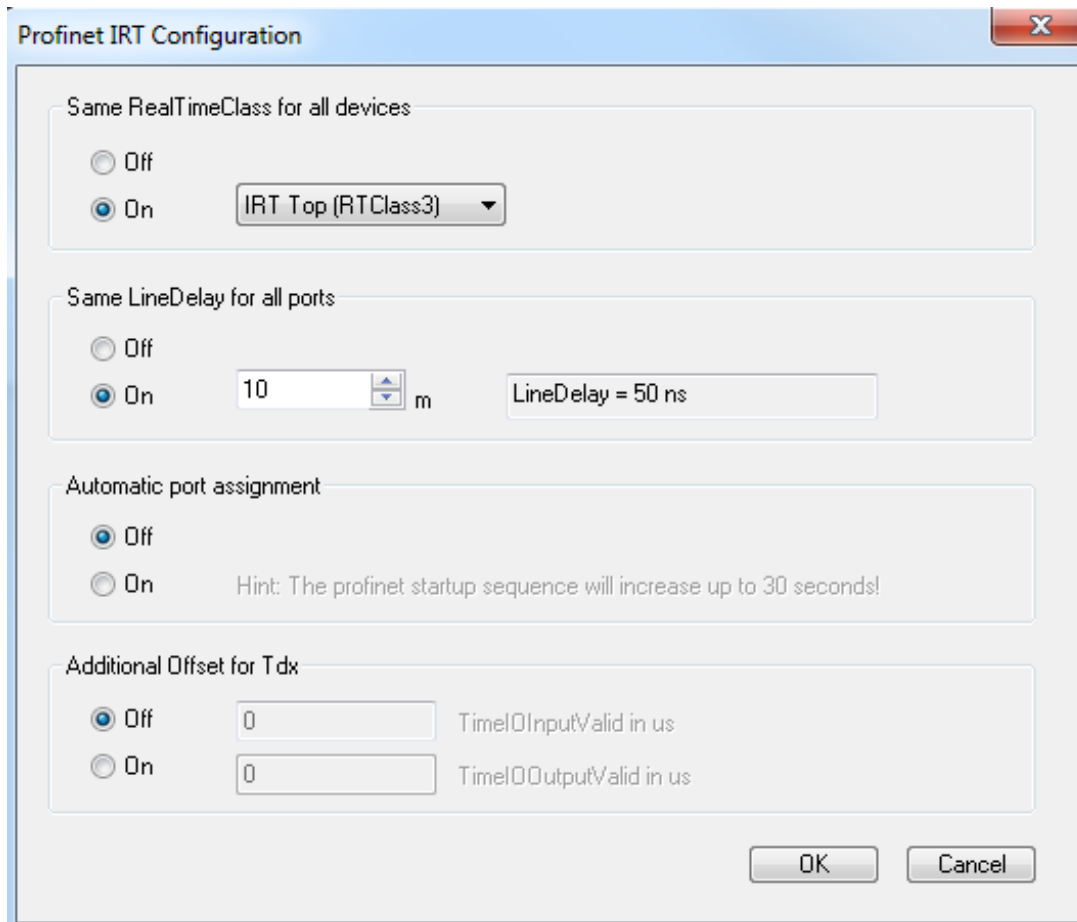

Fig. 25: "PROFINET Port configuration" dialog

On the one hand the type of communication can be specified here. At present only RTClass1 (RT) and RTClass3 (IRT Top) are supported.

In addition there is an option in this dialogue to specify a general cable length (for IRT only). An approximate value or the max. cable length is sufficient here, because for the calculation of IRT communication this value tends to be lower (at 100 Mbaud and copper cable 5 ns/m). For optimization this feature can also be deactivated again later and the exact cable length can then be entered for each individual device (on the port submodules).

Furthermore there is an option here to activate an 'automatic port assignment'. As a result of this the port connection set in the TwinCAT project is irrelevant. Before each restart of the PN communication the topology is read out and the IRT communication is calculated on the basis of this. The advantage of this is that possible cabling errors are minimized. In addition to that the ports can be simply replugged without having to change and reload the TwinCAT project. Only a restart of the PN communication is required (e.g. switch terminal to PREOP or disconnect the cable). As a result of this the bootup of the PROFINET communication can take up to 30 seconds longer. The reason for this is the TTL (TimeToLive) factor in the LLDP MIB. These are set by default to 20 seconds, i.e. only after this time can it be guaranteed that the port connection read is also the current one.

Also, an additional offset for all T_i / T_o values can be specified in this menu.

4.3.2 Task configuration

The PROFINET controller protocol must always be linked with a task. The protocol is also processed with the set task time. Theoretically the controller can also be jointly processed, for example, via a PLC or NC task. However, if a PLC project, for example, is stopped (e.g. by restart or debugging), this results in the PROFINET part also being stopped. In order to avoid such a side effect it is advisable to always create a free-running SyncTask.

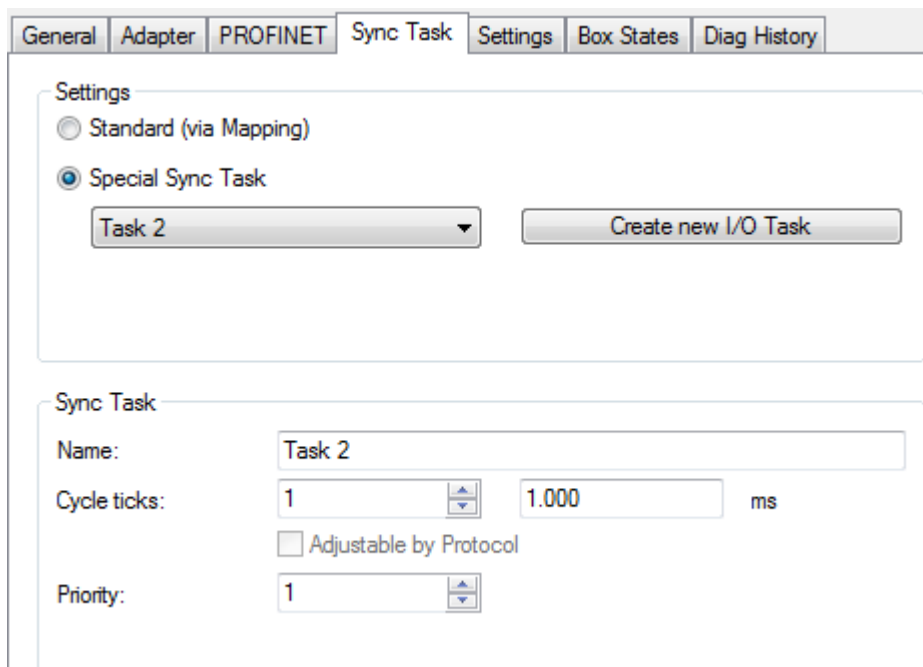

Fig. 26: "Sync Task" tab

It must be ensured that the task cycle lies in a PROFINET cycle, i.e. for PROFINET the basic cycle is 31.25 μ s. This cycle is then always multiplied by the SendClockFactor (SCF) to obtain the basic cycle. The SendClockFactor is usually set to 32 for RTClass1. This is also the minimum PN cycle for RTClass1 for the Beckhoff PROFINET controller and results in the smallest cycle time of 1 ms. Further reductions take place using a ReductionRatioFactor. This always corresponds to a multiple of the minimum PN cycle. For RTClass1 the smallest cycle must always be doubled (permissible cycle times (for RTC1) with an SCF of 32 are 1, 2, 4, 8, ..., 512).

The SCF can and must be reduced in order to achieve faster cycle times for RTClass3 as well. This is presently at least 16 for a Beckhoff IRT controller (EL6632), which corresponds in turn to a basic cycle of 500 μ s. In the case of such a decrease of the PROFINET cycle, it must be noted that the time of the triggering task must also be adapted accordingly.

4.3.3 PROFINET controller-specific settings

Settings that directly concern the controller can be made on the 'Settings' tab.

Fig. 27: "Settings" tab

An IP setting can take place here. The selection of the address range need not correspond to the network card settings. The PROFINET communication spreads its own net, which can be selected here. The IP settings shown in the above illustration are the default settings, i.e. if nothing is changed the controller uses these settings. The same applies to the controller name (system name). The corresponding button must be pressed to change either of these two settings. A check is made to ascertain that the input is correct (e.g. the format of the controller name must correspond to the PN spec.). These data are then permanently adopted. If the subnet or gateway is changed, the settings will also be adopted by possible projected devices. There is also a possibility to modify these settings via a supervisor tool.

In addition the VendorID and DeviceID of the controller can be read out in this dialogue. The server and client UDP port employed can also be set here. The default settings should, however, be adequate in most cases.

Furthermore there is a possibility in this dialogue to enable an automatic PROFINET start-up following a device exchange (including devices without removable media). For correct functioning the nominal topology must be specified once. On the basis of this information the controller can query the alias names of the individual devices. Every device that supports alias names generates such a name for each of its ports. This is composed of the neighborhood IDs (PortId.ChassisId). If this name is queried, the 'new' device answers. If VendorId and DeviceId are correct the device is named with the actual name and a normal PROFINET start-up can subsequently take place. With this mechanism a complete PROFINET system could also start up without having named an individual device beforehand.

4.3.4 Analysis of the box states

Directly below the PROFINET controller protocol there is a collective PROFINET error and a collective PROFINET status. Both indicate the number of devices in which a problem has occurred or in which a diagnosis is available, i.e. the error indicates possible problems with the establishment of a connection or reasons for an abort. The diagnosis provides status information about an existing connection.

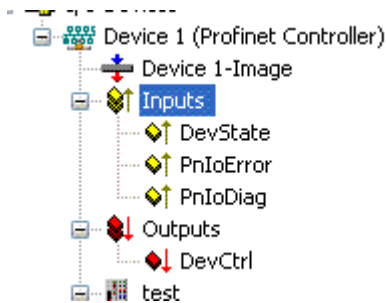

Fig. 28: TwinCAT tree, inputs for analysis

- PnIoError - number of PROFINET IO devices that have an error
- PnIoDiag - number of PROFINET IO devices where a diagnosis is available

It is possible to check at a glance which device or box has a problem in the protocol under Box States.

StationName	Box PnIoState	Box PnIoDiag
test	No Error (0x0)	Diagnosis available (0x12)
bk9103-11	No Error (0x0)	Diagnosis available (0x2)
bk9103-6	No Error (0x0)	Diagnosis available (0x418)
bk9103-4	No Error (0x0)	Diagnosis available (0x2)

Fig. 29: "Box states" tab

Presently the following error messages are displayed under the "PnIoState".

Number	Text	Description	Remedial action / reason
0	No error	No error	No error
1	PROFINET Device state machine is in boot mode	PROFINET Device State Machine is still in the start-up phase	Not an error, wait
2	Device not found	Device does not reply to the Identify Request	Check connection, device connected, was the device called by its correct name?
3	The stationname is not unique	The station name is not unique	There are two or more devices in the network with the same PROFINET name. A correct identification cannot take place.
4	IP could not set	IP address could not be set	The PROFINET device has rejected the IP settings for some reason. Check whether the IP settings are correct.
5	IP conflict	An IP conflict has occurred in the network	A possible cause is that several devices have the same IP address.
6	DCP set was not successful	There was no reply or an erroneous reply to a DCP Set	Check connection, device connected, was the device called by its correct name?
7	Watchdog error	The connection was broken off with a Watchdog error	Check the cycle time, check the connection, if necessary increase the Watchdog factor.
8	Datahold error	The connection was broken off with a Datahold error	Frame Data status was invalid for the length of the DataHoldTimer. Restart the device if necessary.
9	RTC3: Sync signal could not started	For IRT only: the Sync signal could not be started.	Is EtherCAT Sync signal correct or has Sync0 started?
10	PROFINET Controller has a link error	The PROFINET controller has no link	Check cable and connection.
11	The aliasname is not unique	The alias name is not unique	There are two or more devices in the network with the same alias name. This is made up of the neighbourhood information (PortId.ChassisId). A correct identification cannot take place.
12	The automatic name assignment isn't possible - wrong device type	The automatic name assignment is not possible	The expected PROFINET device is not in the projected position (VendorId or DeviceId does not correspond). Hence, no automatic naming and thus no device start is possible.
31	Only for EtherCAT gateways: WC-State of cyclic EtherCAT frame is 1	For EL6631 only: EtherCAT WC State is 1	Check the mode on the EtherCAT master & slave (OP?).

As opposed to the state, more than one status can be displayed in the “BoxPnIoDiag”, i.e. the whole thing is bit-coded and up to 16 pieces of information can be displayed. The following statuses are currently displayed.

0x0000 = No diagnosis
 0xXXX1 = IOC-AR is not established
 0xXXX2 = IOC-AR is established
 0xXXX4 = IOC-AR is established but no ApplReady
 0xXXX8 = IOC-AR is established but module difference
 0xXX1X = At least one AlarmCR get diagnosis alarm
 0xX1XX = At least one InputCR is invalid
 0xX2XX = At least one InputCR Provider is in stop
 0xX4XX = At least one InputCR Problemindicator is set
 0x1XXX = At least one OutputCR is invalid
 0x2XXX = At least one OutputCR Provider is in stop
 0x4XXX = At least one OutputCR Problemindicator is set

On the one hand information about the status of the IO Controller Single AR is displayed here. In addition, collective statuses are formed from the Frame Data statuses of the individual CRs. This applies to the input and output CRs (currently only one CR is possible, in future several). Furthermore a PROFINET alarm is also displayed in “PnIoDiag”

Readout via ADS

The Box Status can be read out via an ADS Read.

ADS Read:
 NetId = AMSNETID des PROFINET Controllers
 Port = BoxPort (0x1000 + BoxId)
 Indexgroup = 0xF829
 IndexOffset = 0
 Length = sizeof(TPnIoDeviceDiagData);

where:

```
typedef struct
{
  WORD pnioState;
  WORD pnioDiag;
  WORD NrOfInputCRs;
  WORD NrOfOutputCRs;
  WORD reserved[8];
} TPnIoDeviceDiagData, *PTPnIoDeviceDiagData;
```

Readout via CoE (for EL663x)

The Box Status can also be read out via CoE for the EL663x. The index 0xAyy0 (where yy is the Adaptor / Device number) and the subindex 0x001 must be taken for this.

4.3.5 Diagnosis history on the controller protocol

Logged diagnosis messages from the controller protocol can be read out on the “Diag History” tab. The diagnosis buffer operates as a ring buffer with a current maximum size of 1000 entries.

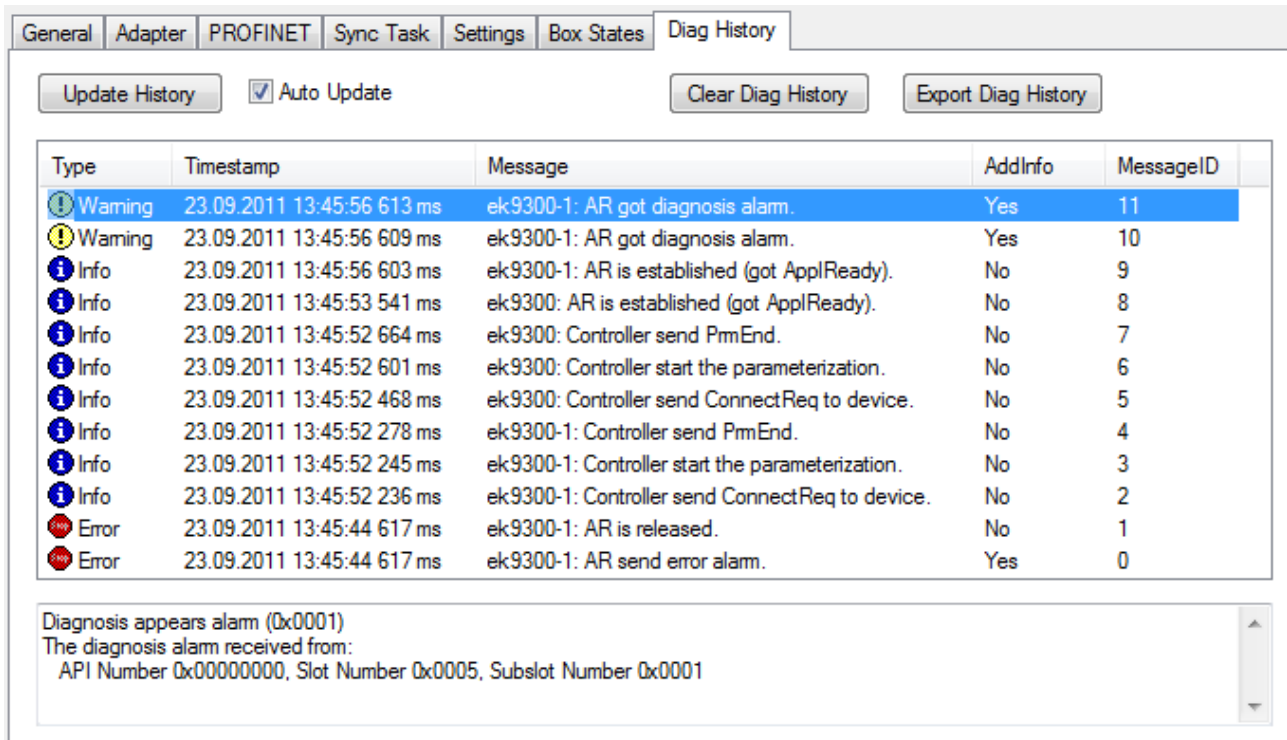

Fig. 30: "Diag History" tab

The possible errors are grouped into three types:

- Info: e.g. information on the connection establishment
- Warning: e.g. PROFINET diagnostic alarms
- Error: e.g. Loss of connection

“AddInfo” indicates whether additional information about the event is available. If this is marked by “Yes”, the additional information can be fetched and displayed by clicking on the respective message. In the case of a diagnosis alarm (“Diagnosis” appears), the precise diagnosis information can be fetched at the corresponding level (device, API or module).

The complete diagnosis buffer is cleared by pressing the “Clear Diag History” button.

The displayed messages can be saved in a .TXT file by pressing the “Export Diag History” button.

4.3.6 Cyclic data

There are several cyclic process data directly below the PROFINET controller protocol. These data are only exchanged between the PROFINET driver and the system manager. They provide general information about the status of the PROFINET communication.

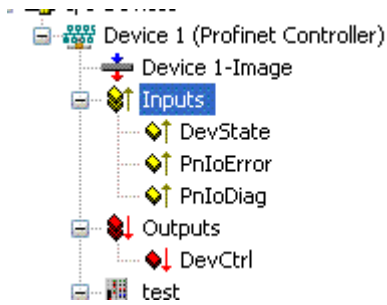

Fig. 31: TwinCAT tree, inputs for info

The 'DevState' variable contains information about the physical communication status of the controller, such as the link status or whether the transmission resources are still sufficient.

The other variables are the collective PROFINET error and the collective PROFINET status. Both indicate the number of devices in which a problem has occurred or in which a diagnosis is available, i.e. the error variable indicates possible problems with the establishment of a connection or reasons for an abort. The diagnostic variable provides status information about an existing connection.

The 'DevCtrl' output variable currently has no function.

For further information, please also read the chapter entitled '[Box States \[► 52\]](#)'.

4.3.7 Acyclic data

The ADS blocks are used to send acyclic data. These then access the PROFINET record data. So that acyclic data can be read or written, the PROFINET device must be in data exchange mode.

An *ADSReadWrite* is set.

ADS settings

AMSNetID: The AMSNetID of the PROFINET controller

PORT: Port number of the device (take this from the system manager)

Index GROUP: 0x0000_F823

Index OFFSET: 0x0000_0000

DATA

```
typedef struct {
    WORD        RW;
    #define     PN_READ      0
    #define     PN_WRITE     1
    WORD        NrOfAR;
    DWORD       API;
    WORD        Slot;
    WORD        SubSlot;
    PNIO_RECORD RecordData;
} PNIO_CONFIGRECORD
```

Table 1: Structure of the record data frame

nRW	nNr	nAPI	nSlot	nSub-Slot	nIndex	nLen	nTrans	nRe-served	Data (only write)
2 bytes	2 bytes	4 bytes	2 bytes	2 bytes	2 bytes	2 bytes	2 bytes	2 bytes	n bytes

Table 2: Meaning of data from the record data frame

Designation	Values	Description
nRW	0 – READ 1 - WRITE	read- or write-access
nNr	normally „0“dec	it is possible to put multiple ARs (application relations) to one device (Controller, Supervisor, DeviceAccess). This indicates in which AR the data is exchanged -> normally there is only one AR, in this case zero.
nAPI	normally „0“dec	-> otherwise, the corresponding application profile should be placed here
nSlot	variable	Slot number
nSubSlot	variable	SubSlot number
nIndex	variable	Index number
nLen	variable	READ if nRW = 0: if the value „0“ is used when reading, the request is sent with the maximum buffer size, if nLen ≠ 0, the corresponding length is used. WRITE if nRW = 1: when writing: number of bytes, which follow from or after the “nReserved” word
nTrans	starts with „1“dec	If multiple records are downloaded at once, this transfer sequence number determines the order in which the data is processed.
nReserved	„0“dec	2 byte alignment
Data	variable	Data (from here the „nLen“ for the data length counts (writing only))

Sample:

Send a read request for I&M function 0

nRW	nNr	nAPI	InSlot	SubSlot	nIndex	nLen	nTrans	nRe- served
00 00	00 00	00 00 00 00	00 00	01 00	F0 AF	00 00	01 00	00 00

Make sure that the receive data memory is large enough!

5 Devices at protocol

5.1 Appending PROFINET devices

Select "Append Box" by right-clicking on the protocol. The following dialogue then opens:

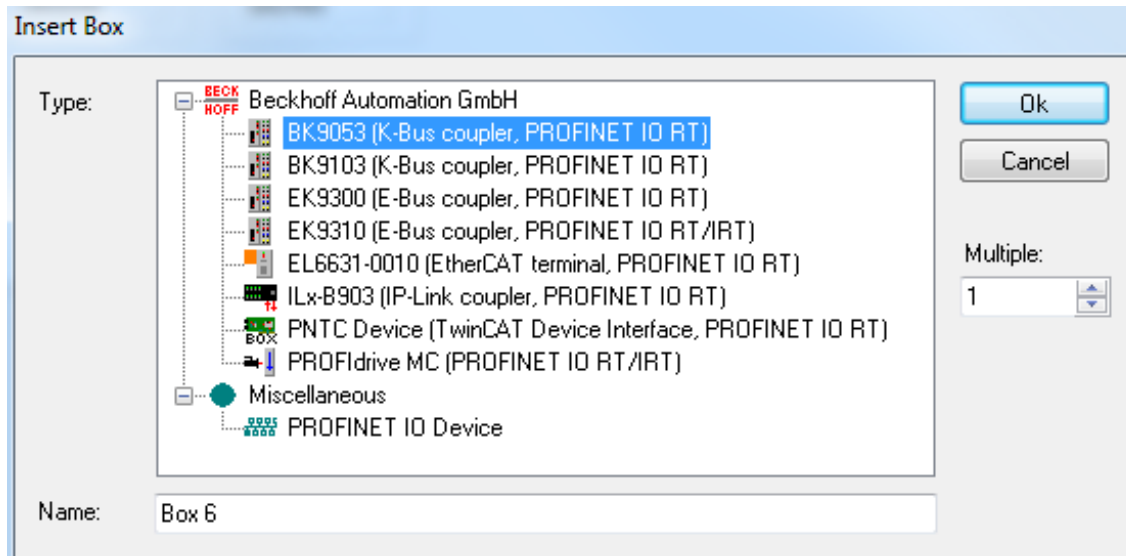

Fig. 32: "Insert Box" dialog

There is a possibility here to select various PROFINET devices. In Beckhoff devices a search is carried out via a defined path for the GSDML “..\TwinCAT\Io\ProfiNet” (TC2) or “..\TwinCAT\3.1\Config\Io\Profinet” (TC3). These should be already present with the TwinCAT installation. If there are several GSDMLs for the same device here, the one with the latest date is taken. If no device description is found, a corresponding error message appears. Either the GSDML is copied into the folder and the menu is opened again, or the same procedure is selected as for the third-party devices. If you click on “PROFINET IO Device”, an option is offered to navigate to the corresponding GSDML in Windows Explorer. This is then integrated into the project.

The DNS name from the GSDML is taken as the default name. When appending several devices simultaneously, the default name is always supplemented by “-No.” (where No. = 1 to n). The name that was assigned (and with which the device also appears in the tree), is at the same time also the “PROFINET Station Name”, i.e. the name that must correspond to the name in the device. The device name can be checked by scanning.

The modules can be attached to the API (Application Profile Interface). The DAP (Device Access Point), which already brings along fixed properties from the GSDML (e.g. process data, interface and port submodules, etc.), is always on Slot 0.

This module is always there and cannot be deleted or shifted. Each further module is assigned to a certain API. The information regarding its identity comes from the GSDML. As standard this is always the API 0. Alternatively, an API e.g. for the PROFIDRIVE profile or a fieldbus API is also conceivable. By clicking in the API on “Append PROFINET modules...” a device catalogue is opened from which the corresponding modules can be selected and appended. If the modules support it (described in GSDML), the submodules can in turn be appended to them in the same way.

5.2 Comparison of nominal and actual configuration

If a connection exists, the project planning can be checked on the “Diagnosis” tab. At this level “Real Identification Data” returns the actually existing modules in an AR, “Expected Identification Data” indicates the expected modules (i.e. those projected in the controller) and “Module Difference” shows the differences to the device found in the nominal-actual comparison.

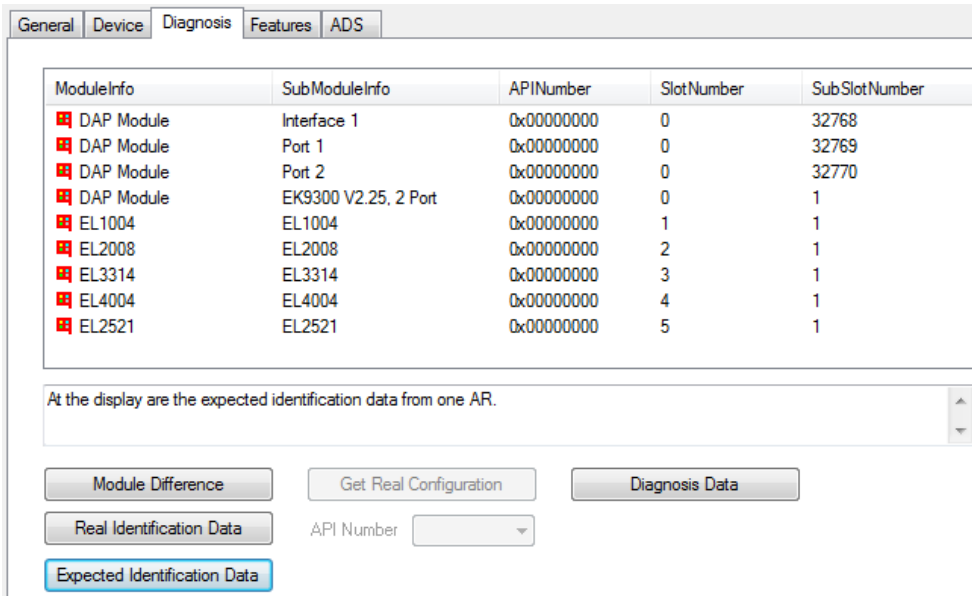

Fig. 33: "Diagnosis" tab, checking the project planning

If you are on the “Diagnosis” tab within the API, you can select the corresponding API about which information is to be obtained. If, for example, the PROFINET device is a drive, then this usually supports the Profdrive profile, which is identified in turn via API 0x3A00. If the Real Identification Data is to be read from this API, for example, then this access takes place via the Profdrive profile.

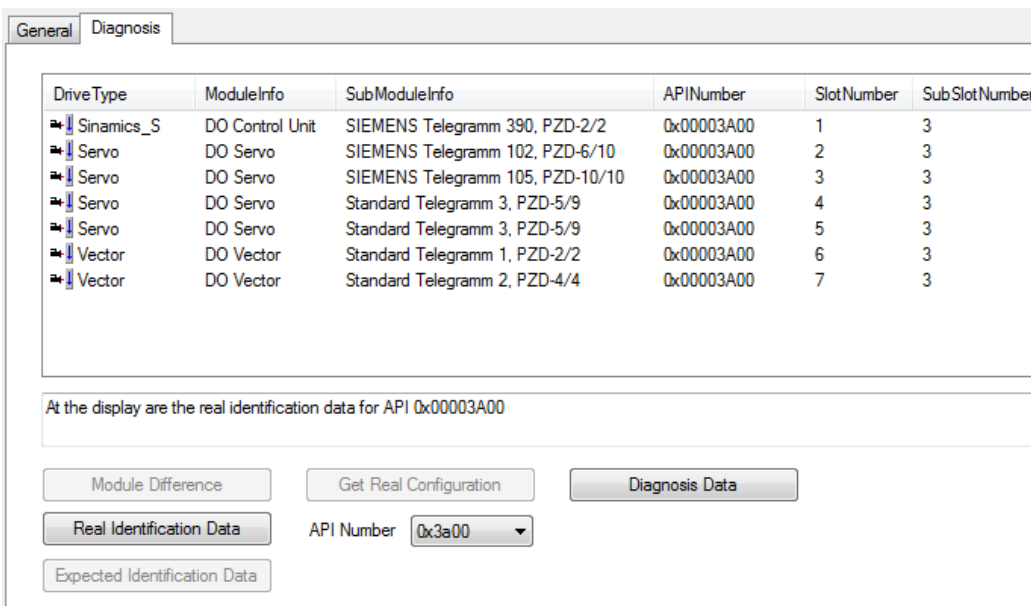

Fig. 34: "Diagnosis" tab, API selection

In addition, the “Get Real Configuration” button becomes active within an API (except for drives). It is possible via this to adopt the read-in data record into the current project. Note that modules that have already been created will be overwritten when doing this. This means that the links are lost, even in the case of previously correctly created modules.

When displaying the module differences, additional information is displayed by marking the message.

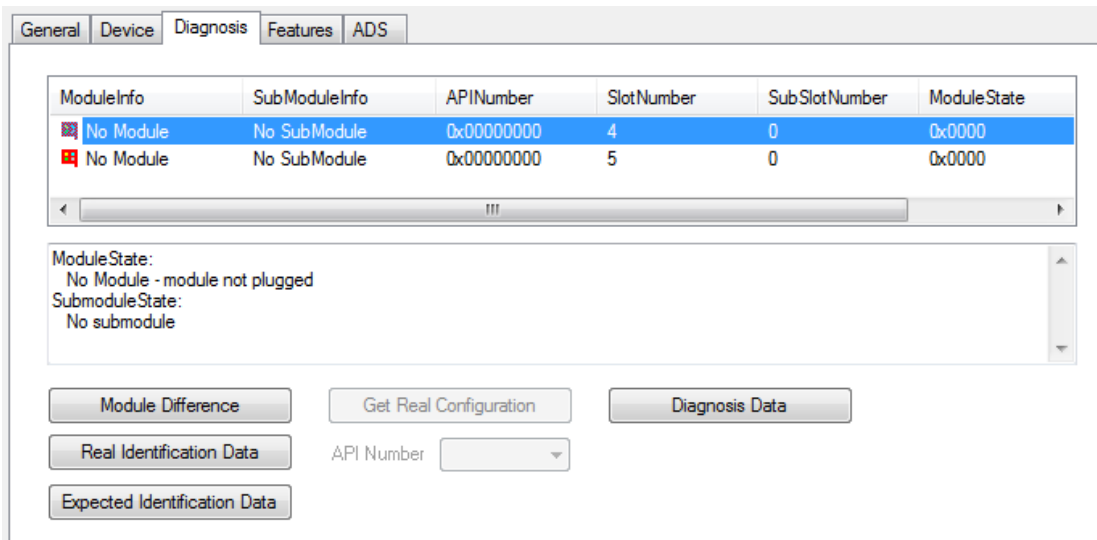

Fig. 35: "Diagnosis" tab, adopt data set into project

Diagnosis Data

The available diagnosis can be read out by pressing the "Diagnosis Data" button. At device level all available diagnosis data for the existing AR is read out here.

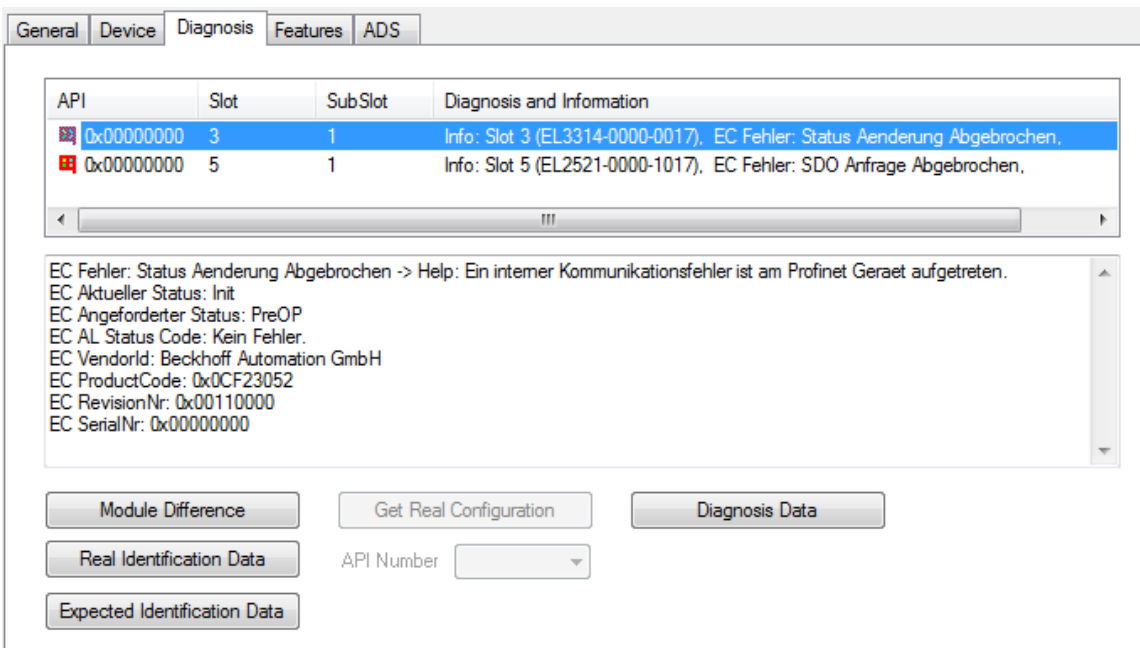

Fig. 36: "Diagnosis", Button Diagnosis Data

A maximum of two diagnosis parameters are displayed in the list; others are marked by "...". If the individual message is clicked, all available diagnosis information is displayed in the window below.

Cyclic diagnosis via "PnIoBoxState" and "PnIoBoxDiag"

These variables are cyclically exchanged with the process image between the PROFINET driver and the System Manager.

Presently the following error messages are displayed under the PnIoBoxState.

Number	Text	Description	Remedial action / reason
0	No error	No error	No error
1	PROFINET Device state machine is in boot mode	PROFINET Device State Machine is still in the start-up phase	Not an error, wait
2	Device not found	Device does not reply to the Identify Request	Check connection, device connected, was the device called by its correct name?
3	The stationname is not unique	The station name is not unique	There are two or more devices in the network with the same PROFINET name. A correct identification cannot take place.
4	IP could not set	IP address could not be set.	The PROFINET device has rejected the IP settings for some reason. Check whether the IP settings are correct.
5	IP conflict	An IP conflict has occurred in the network.	A possible cause is that several devices have the same IP address.
6	DCP set was not successful	There was no reply or an erroneous reply to a DCP Set.	Check connection, device connected, was the device called by its correct name?
7	Watchdog error	The connection was broken off with a Watchdog error.	Check the cycle time, check the connection, if necessary increase the Watchdog factor.
8	Datahold error	The connection was broken off with a Datahold error.	Frame Data status was invalid for the length of the DataHoldTimer. Restart the device if necessary.
9	RTC3: Sync signal could not started	For IRT only: the Sync signal could not be started.	Is EtherCAT Sync signal correct or has Sync0 started?
10	PROFINET Controller has a link error	The PROFINET controller has no link.	Check cable and connection.
11	The aliasname is not unique	The alias name is not unique	There are two or more devices in the network with the same alias name. This is made up of the neighbourhood information (PortId.ChassisId). A correct identification cannot take place.
12	The automatic name assignment isn't possible - wrong device type	The automatic name assignment is not possible.	The expected PROFINET device is not in the projected position (VendorId or DeviceId does not correspond). Hence, no automatic naming and thus no device start is possible.
31	only for EtherCAT gateways: WC-State of cyclic EtherCAT frame is 1	For EL6631 only: EtherCAT WC State is 1	Check the mode on the EtherCAT master & slave (OP?).

As opposed to the state, more than one status can be displayed in the "PnIoBoxDiag", i.e. the whole thing is bit-coded and up to 16 pieces of information can be displayed. The following statuses are currently displayed.

0x0000 = No diagnosis
 0xXXX1 = IOC-AR is not established
 0xXXX2 = IOC-AR is established
 0xXXX4 = IOC-AR is established but no ApplReady
 0xXXX8 = IOC-AR is established but module difference
 0xXX1X = At least one AlarmCR get diagnosis alarm
 0xX1XX = At least one InputCR is invalid
 0xX2XX = At least one InputCR Provider is in stop
 0xX4XX = At least one InputCR Problemindicator is set

0x1XXX = At least one OutputCR is invalid
0x2XXX = At least one OutputCR Provider is in stop
0x4XXX = At least one OutputCR Problemindicator is set

On the one hand information about the status of the IO Controller Single AR is displayed here. In addition, collective statuses are formed from the Frame Data statuses of the individual CRs. The whole thing happens for the input and the output CRs (currently only one is possible; in future the controller will support several CRs). In addition a PROFINET alarm is also displayed in the "PnIoBoxDiag"

5.3 Settings

5.3.1 Project planning of the PROFINET device

When establishing a PROFINET connection the controller always assigns an IP address to the device from its own address space (if the device does not yet have one or if it has a different one). In TwinCAT the next higher address is taken for a device by default (starting from the controller adaptor class); the subnet and gateway are the same as those of the controller. Before the actual assignment of the IP address to the device by the controller, an ARP is used to test for a possible address conflict or to check whether the device already has this IP address. If there is a conflict, e.g. that the IP address is already assigned in the network, the IO driver determines this and outputs a corresponding message in the logger window. If there is no reply to the ARP, this means that no device (the projected device included) is using this IP configuration, which in turn results in the controller assigning the IP settings to the device via a DCP_SET. Setting is skipped if it is determined via the ARP that the device sought already has the projected IP address.

The screenshot shows the 'Device' tab in the TwinCAT configuration interface. It is divided into two main sections: 'Adapter Properties' and 'Instance Properties'.

Adapter Properties:

- Stationname:** A text field containing 'sinamics2'.
- VendorId:** A text field containing '0x002A'.
- DeviceId:** A text field containing '0x0501'.
- HW Version:** A text field containing '2.00'.
- SW Version:** A text field containing 'V 4.30.28'.
- IP configuration:** A group box containing:
 - IP address:** A text field containing '192 . 168 . 1 . 5'.
 - Subnet:** A text field containing '255 . 255 . 255 . 0'.
 - Gateway:** A text field containing '192 . 168 . 1 . 1'.

Instance Properties:

- ID:** A text field containing '0x0000'.
- FrameId:** A text field containing 'Fast Config'.
- MaxLengthIn:** A text field containing '400 Byte'.
- MaxLengthOut:** A text field containing '400 Byte'.
- ActLengthIn:** A text field containing '126 Byte'.
- ActLengthOut:** A text field containing '102 Byte'.

Fig. 37: "Device" tab

In addition the "InstanceID" and the "FrameID" can be changed in this window. However, the default settings are sufficient for most applications. The Instance ID is incorporated into the formation of the UUID object. A change should therefore be made only in exceptional cases. When changing the Frame ID the employed RTClass must be taken into account (e.g. for RTClass1 unicast 0xC000 - 0xFAFF). If the device is on an IRT controller and all devices have been switched automatically to RTClass3, the FrameID is managed automatically and there is no input option (marked by "Fast Config").

In addition the current process data length can be checked in this menu, i.e. the MaxLengths indicate which process data size is supported by the respective device, while the ActLengths indicate the current process data length (incl. IOPS and IOCS). The corresponding error message appears if the maximum lengths are exceeded on appending further modules/submodules.

Various settings for the cycle time can be made on the "Features" tab. The controller cycle time for RTClass1 must always correspond to a power of two, starting from 1 ms (1, 2, 4, 8...). If an incorrect base time has been selected, this is indicated by a corresponding message. For RTClass3 the 1 ms base time can

be divided again and again by two (down to min. 31.25 µs). The device cycle time can be changed via the exponents. The minimum is always the Controller Cycle Time, unless a larger minimum cycle time than that of the controller is defined in the GSDML. The maximum for RTClass1 is 512 ms. The "SendClockFactor" is fixed here as the time base with the value 32 (31.25 µs * 32 = 1 ms). The "ReductionRatioFactor" is also referenced to this, i.e. an RRFactor of 4 means a cycle time of 4 ms. The transmission point can be shifted again within a cycle via the phase; i.e. where RR = 4 the phase can be 1 - 4. However, this value is only of importance in the case of a synchronized transmission.

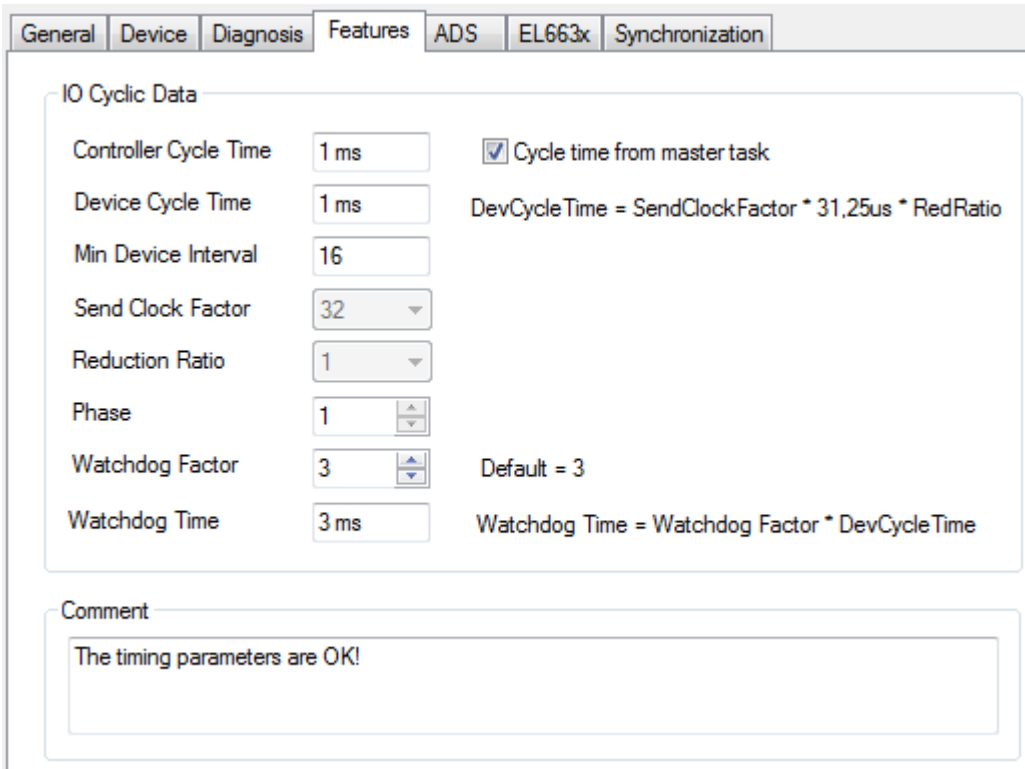

Fig. 38: "Features" tab

In addition there is an option here to adjust the PROFINET Watchdog factor, i.e. each device monitors the input of the cyclic data on the basis of this factor. If the factor is set to the default value (3) this means that, with an RR of 4, three cycles require 12 ms. Hence, a device reacts after 12 ms to missing telegrams (e.g. with an alarm and/or disconnection of the AR). The limits and values are recalculated each time when adjusting the individual factors.

5.3.2 BK9xx3

In the case of the Beckhoff K-Bus Coupler (at present BK9103 or BK9053) that is not connected to an EL663x, an additional menu appears here.

Fig. 39: "BK9xx3" tab

The cyclic process data in the DAP of the Bus Coupler can be accessed easily via this menu.

In addition, a firmware update from the System Manager to the Bus Coupler can be carried out via this menu. If the update takes place by IP it is important to ensure that the IP address is obtained via the DIP switches. If this is not the case the connection breaks off during the update, since the memory area of the IP settings is also formatted and rewritten.

5.3.3 EL663x

If the controller protocol is operated via an EL663x, then an additional menu appears on the devices.

Fig. 40: "EL663x" tab

At present only the choice of the PDO mapping is selectable for the controller; i.e. the form in which the PROFINET process data are mapped to the PDOs on the EtherCAT side is set here.

5.3.4 IRT Controller

If the device is operated on an IRT-capable controller, then an additional menu appears.

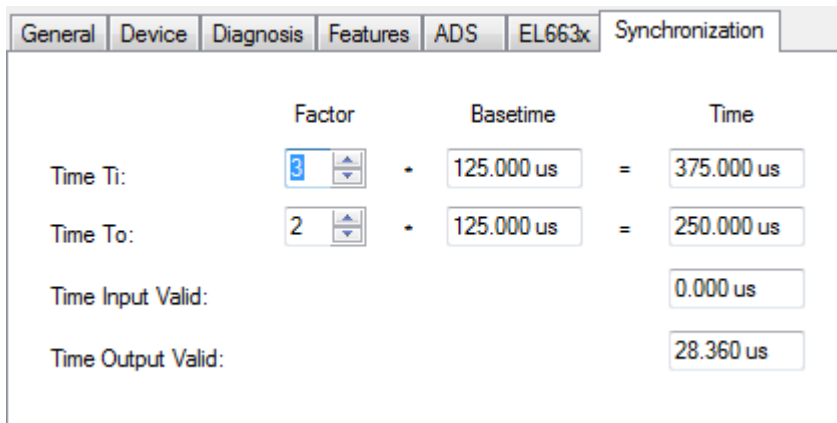

Fig. 41: "Synchronization" tab

It is possible to specify the Ti and To factors for IRT-capable devices via this menu. This means the time during which the data in the device are valid within a cycle, or should be set to valid. The prerequisite is that this feature is also supported. The GSDML supplies the information about this. There is always a basic cycle here (base time). A statement about the minimum possible time comes via the GSDML on the basis of a minimum factor. The upper limit of the factor is limited by the cycle time employed. The shortest possible time in which the data could be valid over PROFINET (always in reference to the cycle) is displayed via the "Time Input Valid" or "Time Output Valid" parameter.

5.3.5 Shared Device

The SharedDevice feature is available from TwinCAT 2 build 22.50 or TwinCAT 3 build 4019.

The dialogue appears if the device supports "SharedDevice". The information for this comes from the GSDML.

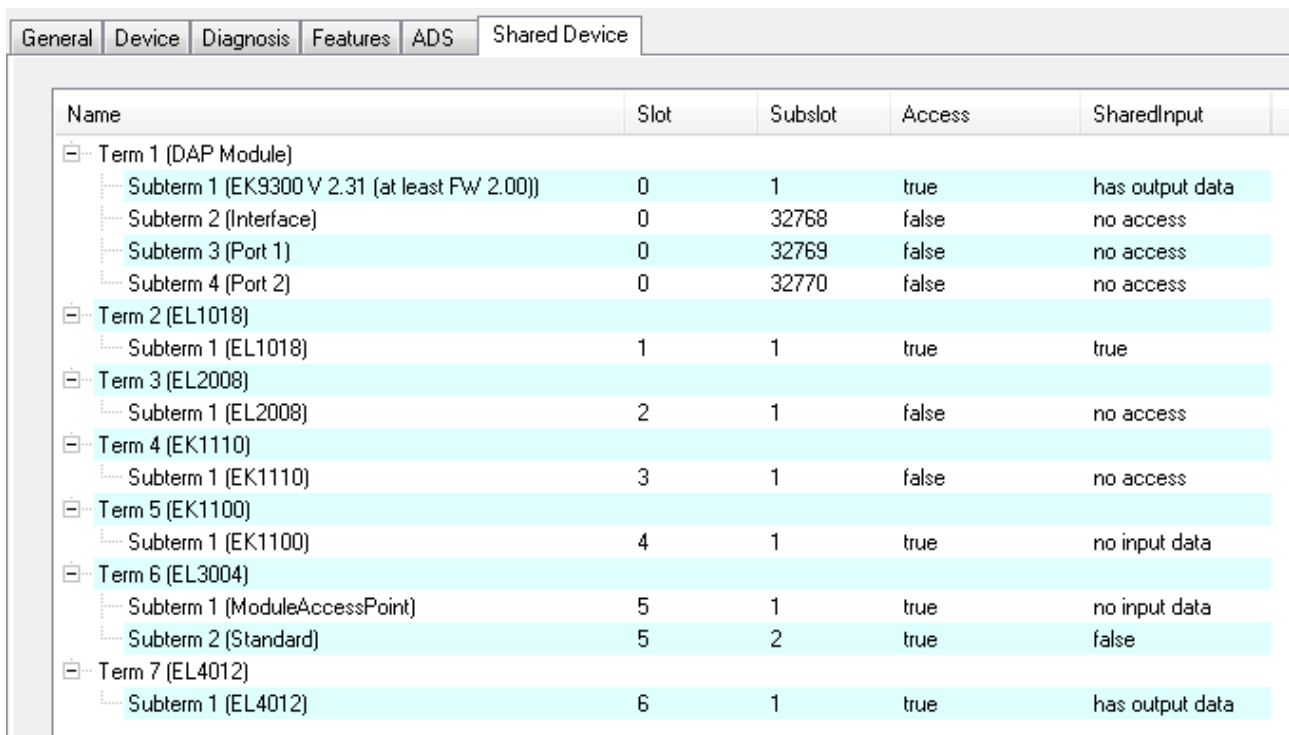

Fig. 42: "Shared Device" tab

There is an option here to allow or forbid the controller to access the individual sub-modules. By default the controller may access all sub-modules; if SharedInput is supported it is switched off.

The text messages for SharedInput have the following meanings:

- "not supported" - SharedInput is not supported by the device (info from the GSDML)

- "has output data" - the sub-module has outputs - activation of SharedInput not possible
- "no input data" - the sub-module has no inputs (and also no outputs)
- "no access" - access is blocked
- "true" or "false" - set value for SharedInput

The settings can be changed by double-clicking on the individual sub-modules. If the access to a port or interface sub-module is changed, then it is changed for all ports or interfaces.

5.4 Modules

5.4.1 Diagnosis at module level

The slot number of the modules always corresponds to the position in the tree, i.e. the DAP module always starts with slot number 0 and so on in order. At module level there is an option on the Diagnostic tab to compare the nominal and actual data for the respective module. In addition the existing diagnosis for the module can be read out.

5.4.2 Diagnosis at submodule level

PROFINET currently distinguishes between 4 types of submodule.

- Virtual submodules:
The virtual submodules are always permanently connected to a module, i.e. when inserting a module the virtual submodules defined with it are also always inserted in the specified subslot. This kind of submodule is presently the commonest method.
- Real submodule:
Here there is a possibility to select the pluggable submodules from a submodule list and to append them to the module. The necessary information is procured from the GSDML. In TwinCAT a module can be selected from such a list with the right mouse button (provided this is supported by the device).
- Port submodule:
The physical properties of a network port are reproduced in such a submodule.
- Interface submodule:
Device-specific properties are defined in the interfaces submodules. These can be, for example, additionally supported protocols, timing properties, supported MIBs etc.

In general the submodules have the same diagnostic properties as the modules, i.e. in this case also it is currently only possible to read out the nominal and actual configuration in TwinCAT. The order of the subslot numbers is not necessarily the same as the order in the TwinCAT project. Hence, for example, the order in DAP always starts with the interface submodule (ISM); however, the subslot number of the ISM is defined in the GSDML and starts at 0x8000. There are 16 possible interfaces (0x8x00), each with up to 256 ports (0x80xx). An ISM is followed by the Port submodule with the aforementioned subslot number.

5.4.3 Interface Submodule

The type of communication can always be set on the interface submodel (at present RTClass1 or RTClass3). The only exception is in the case that a generally valid RTClass was set via the 'Auto Config...' menu.

If communication takes place over RTClass3, then the PLL window can additionally be set at the interface.

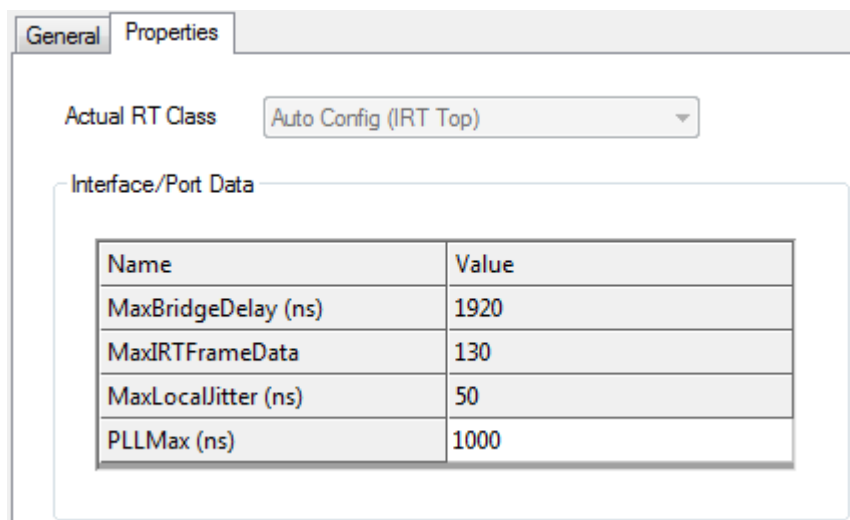

Fig. 43: "Properties" tab, "PLL Window" setting

5.4.4 Port Submodule

Port-specific settings can be made on the 'Properties' tab. The menu of possible settings always depends on the RTClass employed.

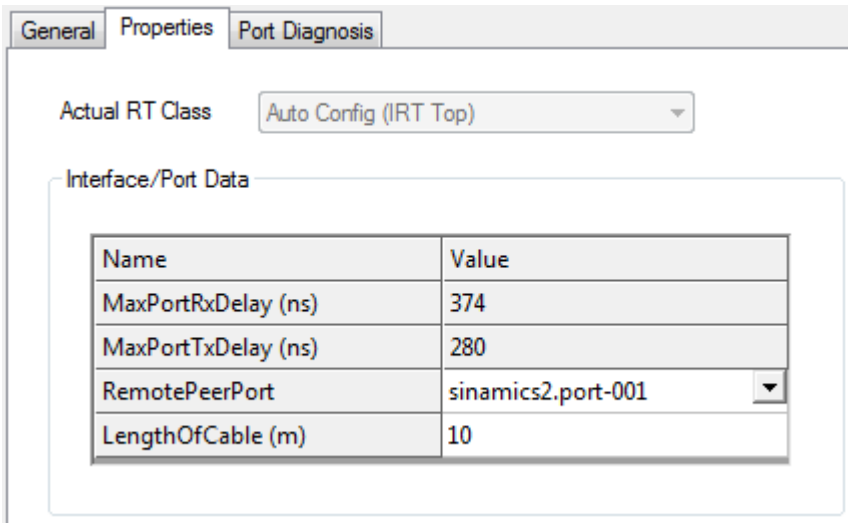

Fig. 44: "Properties" tab

In addition some port properties can be read out.

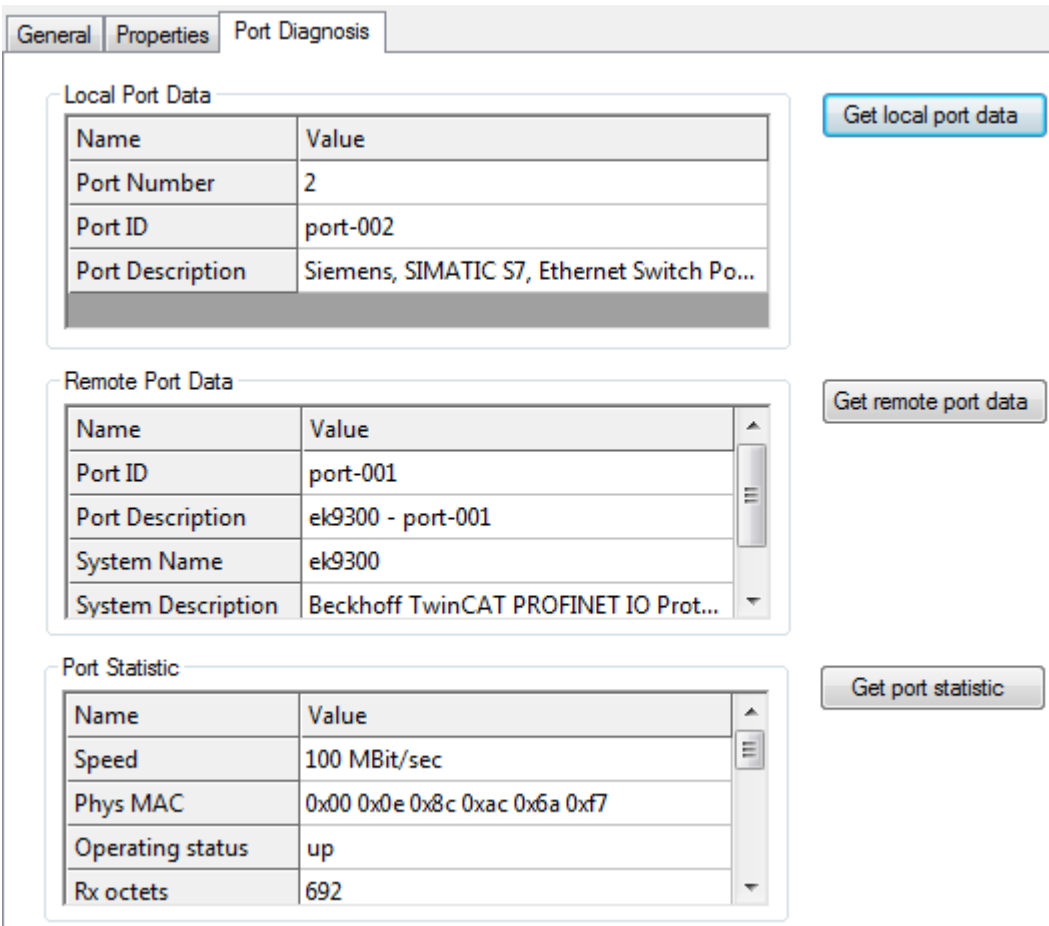

Fig. 45: "Port Diagnosis" tab

The information here is subdivided into local port information and remote port properties. I.e. the LLDP protocol (IEEE Std 802.1AB) is prescribed in PROFINET from Conformance Class A (CCA). The devices exchange neighbourhood IDs via this protocol, so that each port is known to its neighbor. Furthermore, the Simple Network Management Protocol (SNMP) can be used as an aid at this point. On opening the 'Port

Diagnosis' tab, TwinCAT acts as a Network Management Station (NMS) and collects the required device information via SNMP. In the above illustration, for example, it can be seen that the local Port 1 of the BK9053 is connected to Port 2 of the BK9103. For correct topology recognition it is important that only devices are present in the strand that also support the LLDP protocol (this is also applies to switches!).

5.4.5 Real / virtual submodules

If these submodules have paramétrisation data they will be displayed as shown in the illustration below.

Name	R/W	Offline Value	Online Value
Sammeldiagnose	R/W	0	
Diag: Über-/Unterlauf	R/W	0	
Diag: Drahtbruch E-Kanal 0	R/W	0	
Diag: Drahtbruch E-Kanal 1	R/W	0	
Glättung E-Kanal 0	R/W	keine	
Glättung E-Kanal 1	R/W	keine	
Messart/-bereich, E-Kanal 0	R/W	Spannung +/- 10 V	
Messart/-bereich, E-Kanal 1	R/W	Spannung +/- 10 V	
Prozessalarm bei Grenzwertüberschre...	R/W	0	
Oberer Grenzwert E-Kanal 0	R/W	32511	
Unterer Grenzwert E-Kanal 0	R/W	33024	
Prozessalarm bei Grenzwertüberschre...	R/W	0	
Oberer Grenzwert E-Kanal 1	R/W	32511	
Unterer Grenzwert E-Kanal 1	R/W	33024	

Read

Write

Set to Default

Klicken Sie auf das Feld, um sich die verfügbaren Meßarten und Meßbereiche anzeigen zu lassen und auszuwählen. Empfehlung: Nichtbeschaltete Eingangskanäle sollten Sie deaktivieren (Eingabeart: deaktiviert), um die Baugruppenzykluszeit zu verkürzen.

Fig. 46: "Parameterize Module" tab, parameter display

Selection can be made here between the individual indices. The data can be read and/or written depending on the access method. The online values are updated when reading back. If an individual index is marked, then all values within an index will be set to default; if individual values are marked, only these will be reset. Writable values are changed by double-clicking on the respective line.

6 TwinCAT library and programming

6.1 Overview

There are ready-to-use function blocks for the use of the PROFINET controller. The library contains further function blocks for the EL6631-0010 PROFINET Device Terminal, but these are not part of this documentation.

 (https://infosys.beckhoff.com/content/1033/el6631_el6632/Resources/2595517963.zip)

I&M functions

Block I&M functions	Meaning	Description
FB_PN_IM0_READ [▶ 74]	Read the I&M function 0	Supplement and EL663x
FB_PN_IM1_READ [▶ 75]	Read the I&M function 1	Supplement and EL663x
FB_PN_IM2_READ [▶ 77]	Read the I&M function 2	Supplement and EL663x
FB_PN_IM3_READ [▶ 79]	Read the I&M function 3	Supplement and EL663x
FB_PN_IM4_READ [▶ 82]	Read the I&M function 4	Supplement and EL663x
FB_PN_IM1_WRITE [▶ 76]	Write the I&M function 1	Supplement and EL663x
FB_PN_IM2_WRITE [▶ 78]	Write the I&M function 2	Supplement and EL663x
FB_PN_IM3_WRITE [▶ 80]	Write the I&M function 3	Supplement and EL663x
FB_PN_IM4_WRITE [▶ 82]	Write the I&M function 4	Supplement and EL663x

Statistics and diagnostic information

Block I&M functions	Meaning	Description
FB_PN_GET_PORT_STATISTIC [▶ 83]	Read the port statistics	Supplement and EL663x
FB_PN_READ_PORT_DIAG [▶ 84]	Read the port diagnosis	Supplement and EL663x

Development environment	Target platform	PLC libraries to include
TwinCAT v2.11.0 R3	PC or CX (x86, ARM)	TcEtherCAT.lib TcPicloFunction.lib TcUtilities.lib TcSystem.lib TcBase.lib

6.2 Functions

6.2.1 I&M

6.2.1.1 FUNCTION_BLOCK FB_PN_IM0_READ

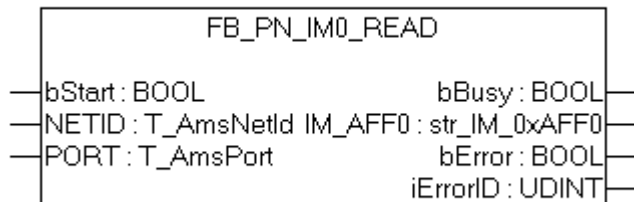

Fig. 47: FUNCTION_BLOCK FB_PN_IM0_READ

Using this function block the PROFINET controller reads all I&M 0 data (Identification & Maintenance) from a device referenced via the *Port* input.

The frame structure of the I&M0 function corresponds to the index [0xAFF0](#) [[▶ 87](#)] according to PROFINET standard.

VAR_INPUT

```
VAR_INPUT
  bStart   : BOOL;
  NETID    : T_AmsNetId; (* AMS Net ID from Controller *)
  PORT     : T_AmsPort; (* Port used by Controller to communicate with Device *)
END_VAR
```

bStart: The block is activated by a rising edge on this input

NETID: AMS Net ID des Controllers

PORT: Port via which the controller communicates with the device (port = Device ID + 1000 hex)

VAR_OUTPUT

```
VAR_OUTPUT
  bBusy    : BOOL;
  IM_AFF0  : str_IM_0xAFF0;
  bError   : BOOL;
  iErrorID : UDINT;
END_VAR
```

bBusy: When the function block is activated this output is set. It remains set until a feedback is received. While Busy = TRUE, no new command will be accepted at the inputs.

IM_AFF0: Output of the I&M0 frame supplied by the device in a structure. str_IM_0xAFF0.

bError: In the event of an error during the command transfer, this output is set once the *bBusy* output has been reset.

iErrorID: Supplies an [ADS error number](#) when the output *bError* is set.

Development environment	Target platform	PLC libraries to be linked
TwinCAT v2.11.0 R3	PC or CX (x86, ARM)	TcProfinetDiag.Lib

6.2.1.2 FUNCTION_BLOCK FB_PN_IM1_READ

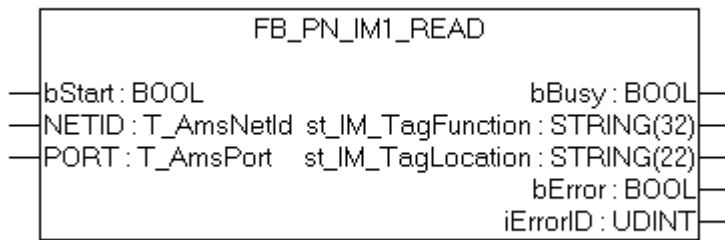

Fig. 48: FUNCTION_BLOCK FB_PN_IM1_READ

Using this function block the PROFINET controller reads all I&M1 data (Information & Maintenance) from a device referenced via the *Port* input.

The frame structure of the I&M1 function corresponds to the index [0xAFF1](#) [[▶ 87](#)] according to PROFINET standard.

VAR_INPUT

```
VAR_INPUT
  bStart      : BOOL;
  NETID       : T_AmsNetId; (* AMS Net ID from Controller *)
  PORT        : T_AmsPort; (* Port used by Controller to communicate with Device *)
END_VAR
```

bStart: The block is activated by a rising edge on this input

NETID: AMS Net ID of the controller

PORT: Port via which the controller communicates with the device (port = Device ID + 1000 hex)

VAR_OUTPUT

```
VAR_OUTPUT
  bBusy       : BOOL;
  st_IM_TagFunction : STRING(32);
  st_IM_TagLocation : STRING(22);
  bError      : BOOL;
  iErrorID    : UDINT;
END_VAR
```

bBusy: When the function block is activated this output is set. It remains set until a feedback is received. While Busy = TRUE, no new command will be accepted at the inputs.

st_IM_TagFunction: label read out for the function of the device.

st_IM_TagLocation: label read out for the installation site of the device.

bError: In the event of an error during the command transfer, this output is set once the *bBusy* output has been reset.

iErrorID: Supplies an [ADS error number](#) when the output *bError* is set.

Development environment	Target platform	PLC libraries to be linked
TwinCAT v2.11.0 R3	PC or CX (x86, ARM)	TcProfinetDiag.Lib

6.2.1.3 FUNCTION_BLOCK FB_PN_IM1_WRITE

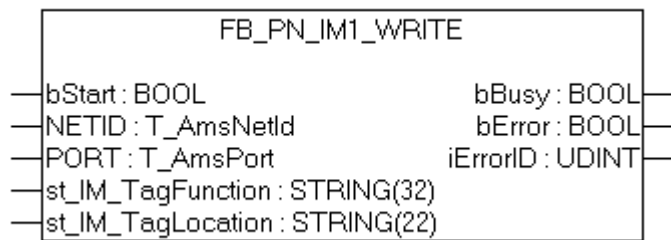

Fig. 49: FUNCTION_BLOCK FB_PN_IM1_WRITE

Using this function block the PROFINET controller writes all I&M1 data (Identification & Maintenance) data to a device referenced via the *Port* input.

The frame structure of the I&M1 function corresponds to the index [0xAFF1](#) | [87](#) according to PROFINET standard.

VAR_INPUT

```
VAR_INPUT
  bStart      : BOOL;
  NETID       : T_AmsNetId; (* AMS Net ID from Controller *)
  PORT        : T_AmsPort; (* Port used by Controller to communicate with Device *)
  st_IM_TagFunction : STRING(32);
  st_IM_TagLocation  : STRING(22);
END_VAR
```

bStart: The function block is activated by a positive edge at this input

NETID: AMS Net ID of the controller

PORT: Port via which the controller communicates with the device (port = Device ID + 1000 hex)

st_IM_TagFunction: With this string the functional description is saved to the device.

st_IM_TagLocation: With this string the installation site is saved to the device.

VAR_OUTPUT

```
VAR_OUTPUT
  bBusy       : BOOL;
  bError      : BOOL;
  iErrorID    : UDINT;
END_VAR
```

bBusy: When the function block is activated this output is set. It remains set until a feedback is received. While Busy = TRUE, no new command will be accepted at the inputs.

bError: In the event of an error during the command transfer, this output is set once the *bBusy* output has been reset.

iErrorID: Supplies an ADS error number when the output *bError* is set..

Development environment	Target platform	PLC libraries to be linked
TwinCAT v2.11.0 R3	PC or CX (x86, ARM)	TcProfinetDiag.Lib

6.2.1.4 FUNCTION_BLOCK FB_PN_IM2_READ

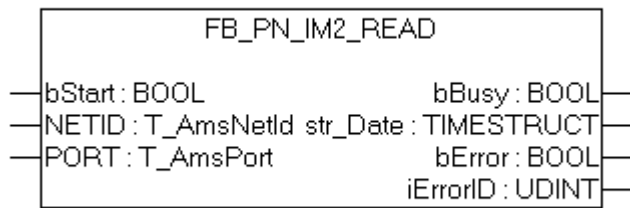

Fig. 50: FUNCTION_BLOCK FB_PN_IM2_READ

Using this function block the PROFINET controller reads all I&M 2 data (Identification & Maintenance) from a device referenced via the *Port* input.

The frame structure of the I&M2 function corresponds to the index [0xAFF2](#) [[▶ 88](#)] according to PROFINET standard.

VAR_INPUT

```
VAR_INPUT
  bStart   : BOOL;
  NETID    : T_AmsNetId; (* AMS Net ID from Controller *)
  PORT     : T_AmsPort; (* Port used by Controller to communicate with Device *)
END_VAR
```

bStart: The function block is activated by a positive edge at this input

NETID: AMS Net ID of the controller

PORT: Port via which the controller communicates with the device (port = Device ID + 1000 hex)

VAR_OUTPUT

```
VAR_OUTPUT
  bBusy      : BOOL;
  str_Date   : TIMESTRUCT; (*YYYY-MM-DD HH:MM*)
  bError     : BOOL;
  iErrorID   : UDINT;
END_VAR
```

bBusy: When the function block is activated this output is set. It remains set until a feedback is received. While Busy = TRUE, no new command will be accepted at the inputs.

str_Date: Returns the date of installation of the device in the format < YYYY-MM-DD HH:MM >.

bError: In the event of an error during the command transfer, this output is set once the *bBusy* output has been reset.

iErrorID: Supplies an [ADS error number](#) when the output *bError* is set.

Development environment	Target platform	PLC libraries to be linked
TwinCAT v2.11.0 R3	PC or CX (x86, ARM)	TcProfinetDiag.Lib

6.2.1.5 FUNCTION_BLOCK FB_PN_IM2_WRITE

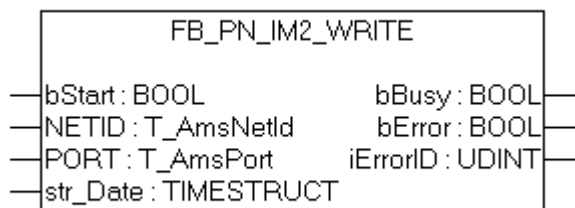

Fig. 51: FUNCTION_BLOCK FB_PN_IM2_WRITE

Using this function block the PROFINET controller writes all I&M 2 data (Identification & Maintenance) data to a device referenced via the *Port* input.

The frame structure of the I&M2 function corresponds to the index [0xAFF2](#) [[▶ 88](#)] according to PROFINET standard.

VAR_INPUT

```
VAR_INPUT
  bStart   : BOOL;
  NETID    : T_AmsNetId; (* AMS Net ID from Controller *)
  PORT     : T_AmsPort; (* Port used by Controller to communicate with Device *)
  str_Date : TIMESTRUCT; (*YYYY-MM-DD HH:MM*)
END_VAR
```

bStart: The function block is activated by a positive edge at this input

NETID: AMS Net ID of the controller

PORT: Port via which the controller communicates with the device (port = Device ID + 1000hex)

str_Date : Writes a date (e.g. date of installation of the device) to the device in the format < YYYY-MM-DD HH:MM >.

VAR_OUTPUT

```
VAR_OUTPUT
  bBusy      : BOOL;
  bError     : BOOL;
  iErrorID   : UDINT;
END_VAR
```

bBusy: When the function block is activated this output is set. It remains set until a feedback is received. While Busy = TRUE, no new command will be accepted at the inputs.

bError: If an error should occur during the transmission of the command, this output is set after the *bBusy* output has been reset.

iErrorID: Supplies an [ADS error number](#) when the output *bError* is set.

Development environment	Target platform	PLC libraries to be linked
TwinCAT v2.11.0 R3	PC or CX (x86, ARM)	TcProfinetDiag.Lib

6.2.1.6 FUNCTION_BLOCK FB_PN_IM3_READ



Fig. 52: FUNCTION_BLOCK FB_PN_IM3_READ

Using this function block the PROFINET controller reads all I&M3 data (Identification & Maintenance) from a device referenced via the *Port* input.

The frame structure of the I&M3 function corresponds to the index 0xAFF3 [▶ 88] according to PROFINET standard.

VAR_INPUT

```
VAR_INPUT
  bStart :
  BOOL; NETID : T_AmsNetId; (* AMS Net ID from Controller *)
  PORT : T_AmsPort; (* Port used by Controller to communicate with Device *)
END_VAR
```

bStart: The function block is activated by a positive edge at this input

NETID: AMS Net ID of the controller

PORT: Port via which the controller communicates with the device (port = Device ID + 1000 hex)

VAR_OUTPUT

```
VAR_OUTPUT
  bBusy : BOOL;
  st_IM_Descriptor : STRING(54);
  bError : BOOL;
  iErrorID : UDINT;
END_VAR
```

bBusy: When the function block is activated this output is set. It remains set until a feedback is received. While Busy = TRUE, no new command will be accepted at the inputs.

st_IM_Descriptor: Returns the manufacturer description stored for the device.

bError: In the event of an error during the command transfer, this output is set once the *bBusy* output has been reset.

iErrorID: Supplies an ADS error number when the output *bError* is set.

Development environment	Target platform	PLC libraries to be linked
TwinCAT v2.11.0 R3	PC or CX (x86, ARM)	TcProfinetDiag.Lib

6.2.1.7 FUNCTION_BLOCK FB_PN_IM3_WRITE

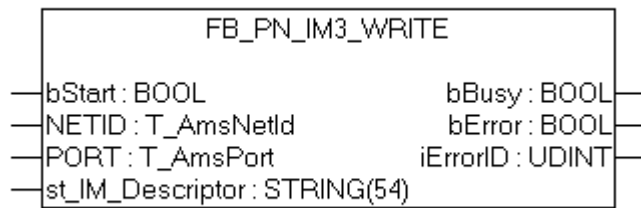

Fig. 53: FUNCTION_BLOCK FB_PN_IM3_WRITE

Using this function block the PROFINET controller writes all I&M3 data (Identification & Maintenance) data to a device referenced via the *Port* input.

The frame structure of the I&M3 function corresponds to the index [0xAFF3](#) [► 88] according to PROFINET standard.

VAR_INPUT

```
VAR_INPUT
  bStart      : BOOL;
  NETID       : T_AmsNetId; (* AMS Net ID from Controller *)
  PORT        : T_AmsPort;  (* Port used by Controller to communicate with Device *)
  st_IM_Descriptor : STRING(54);
END_VAR
```

bStart: The function block is activated by a positive edge at this input

NETID: AMS Net ID of the controller

PORT: Port via which the controller communicates with the device (port = Device ID + 1000 hex)

st_IM_Descriptor: Returns the manufacturer description stored for the device.

VAR_OUTPUT

```
VAR_OUTPUT
  bBusy       : BOOL;
  bError      : BOOL;
  iErrorID    : UDINT;
END_VAR
```

bBusy: When the function block is activated this output is set. It remains set until a feedback is received. While Busy = TRUE, no new command will be accepted at the inputs.

bError: In the event of an error during the command transfer, this output is set once the *bBusy* output has been reset.

iErrorID: Supplies an [ADS error number](#) when the output *bError* is set.

Development environment	Target platform	PLC libraries to be linked
TwinCAT v2.11.0 R3	PC or CX (x86, ARM)	TcProfinetDiag.Lib

6.2.1.8 FUNCTION_BLOCK FB_PN_IM4_READ

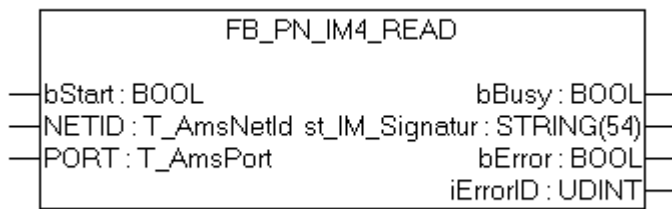

Fig. 54: FUNCTION_BLOCK FB_PN_IM4_READ

Using this function block the PROFINET controller reads all I&M4 data (Identification & Maintenance) from a device referenced via the *Port* input.

The frame structure of the I&M4 function corresponds to the index [0xAFF4](#) [[▶ 88](#)] according to PROFINET standard.

VAR_INPUT

```
VAR_INPUT
  bStart   : BOOL;
  NETID    : T_AmsNetId; (* AMS Net ID from Controller *)
  PORT     : T_AmsPort;  (* Port used by Controller to communicate with Device *)
END_VAR
```

bStart: The function block is activated by a positive edge at this input

NETID: AMS Net ID of the controller

PORT: Port via which the controller communicates with the device (port = Device ID + 1000 hex)

VAR_OUTPUT

```
VAR_OUTPUT
  bBusy      : BOOL;
  st_IM_Signatur : STRING(54);
  bError     : BOOL;
  iErrorID   : UDINT;
END_VAR
```

bBusy: When the function block is activated this output is set. It remains set until a feedback is received. While Busy = TRUE, no new command will be accepted at the inputs.

st_IM_Signatur: Returns the manufacturer signature stored for the device.

bError: In the event of an error during the command transfer, this output is set once the *bBusy* output has been reset.

iErrorID: Supplies an ADS error number when the output *bError* is set.

Development environment	Target platform	PLC libraries to be linked
TwinCAT v2.11.0 R3	PC or CX (x86, ARM)	TcProfinetDiag.Lib

6.2.1.9 FUNCTION_BLOCK FB_PN_IM4_WRITE

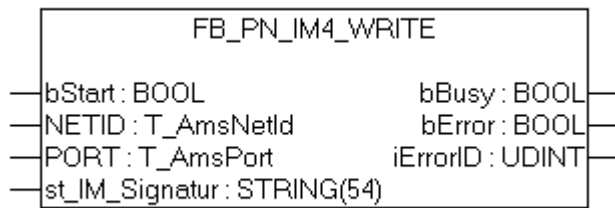

Fig. 55: FUNCTION_BLOCK FB_PN_IM4_WRITE

Using this function block the PROFINET controller writes all I&M4 data (Identification & Maintenance) data to a device referenced via the *Port* input.

The frame structure of the I&M4 function corresponds to the index [0xAFF4](#) [[▶ 88](#)] according to PROFINET standard.

VAR_INPUT

```
VAR_INPUT
  bStart      : BOOL;
  NETID       : T_AmsNetId; (* AMS Net ID from Controller *)
  PORT        : T_AmsPort; (* Port used by Controller to communicate with Device *)
  st_IM_Signatur : STRING(54);
END_VAR
```

bStart: The function block is activated by a positive edge at this input

NETID: AMS Net ID of the controller

PORT: Port via which the controller communicates with the device (port = Device ID + 1000 hex)

st_IM_Signatur: Signature of the manufacturer is written to the device.

VAR_OUTPUT

```
VAR_OUTPUT
  bBusy       : BOOL;
  bError      : BOOL;
  iErrorID    : UDINT;
END_VAR
```

bBusy: When the function block is activated this output is set. It remains set until a feedback is received. While Busy = TRUE, no new command will be accepted at the inputs.

bError: In the event of an error during the command transfer, this output is set once the *bBusy* output has been reset.

iErrorID: Supplies an [ADS error number](#) when the output *bError* is set.

Development environment	Target platform	PLC libraries to be linked
TwinCAT v2.11.0 R3	PC or CX (x86, ARM)	TcProfinetDiag.Lib

6.2.2 Port

6.2.2.1 FUNCTION_BLOCK FB_PN_GET_PORT_STATISTIC



Fig. 56: FUNCTION_BLOCK FB_PN_GET_PORT_STATISTIC

When called, this module supplies the statistical data for the ports of a PROFINET device.

VAR_INPUT

```
VAR_INPUT
  bStart      : BOOL;
  NETID       : T_AmsNetId; (* AMS Net ID from Controller *)
  PORT        : T_AmsPort; (* Port used by Controller to communicate with Device *)
END_VAR
```

bStart: The function block is activated by a positive edge at this input

NETID: AMS Net ID of the controller

PORT: Port via which the controller communicates with the device (port = Device ID + 1000 hex)

VAR_OUTPUT

```
VAR_OUTPUT
  bBusy       : BOOL;
  str_RemotePort_1 : str_GetPortStatistic [► 89];
  str_RemotePort_2 : str_GetPortStatistic [► 89];
  bPort1      : BOOL;
  bPort2      : BOOL;
END_VAR
```

bBusy: When the function block is activated this output is set. It remains set until a feedback is received. While Busy = TRUE, no new command will be accepted at the inputs.

str_RemotePort_1: This structure contains the statistical data for Port 1.

str_RemotePort_2: This structure contains the statistical data for Port 2.

bPort1: Is TRUE if the port has a link.

bPort2: Is TRUE if the port has a link.

Development environment	Target platform	PLC libraries to be linked
TwinCAT v2.11.0 R3	PC or CX (x86, ARM)	TcProfinetDiag.Lib

6.2.2.2 FUNCTION_BLOCK FB_PN_READ_PORT_DIAG

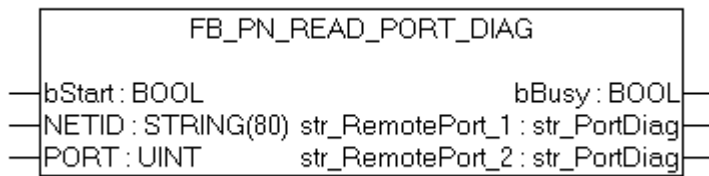

Fig. 57: FUNCTION_BLOCK FB_PN_READ_PORT_DIAG

This block calls the port diagnostic information of a PROFINET device.

VAR_INPUT

```
VAR_INPUT
  bStart      : BOOL;
  NETID       : T_AmsNetId; (* AMS Net ID from Controller *)
  PORT        : T_AmsPort; (* Port used by Controller to communicate with Device *)
END_VAR
```

bStart: The function block is activated by a positive edge at this input

NETID: AMS Net ID of the controller

PORT: Port via which the controller communicates with the device (port = Device ID + 1000 hex)

VAR_OUTPUT

```
VAR_OUTPUT
  bBusy       : BOOL;
  str_RemotePort_1 : str_PortDiag [┆90];
  str_RemotePort_2 : str_PortDiag [┆90];
END_VAR
```

bBusy: When the function block is activated this output is set. It remains set until a feedback is received. While Busy = TRUE, no new command will be accepted at the inputs.

str_RemotePort_1: This structure contains the diagnostic information for Port 1.

str_RemotePort_2: This structure contains the diagnostic information for Port 2.

Development environment	Target platform	PLC libraries to be linked
TwinCAT v2.11.0 R3	PC or CX (x86, ARM)	TcPROFINETDiag.Lib

6.2.3 AlarmDiag

6.2.3.1 FUNCTION_BLOCK FB_PN_ALARM_DIAG

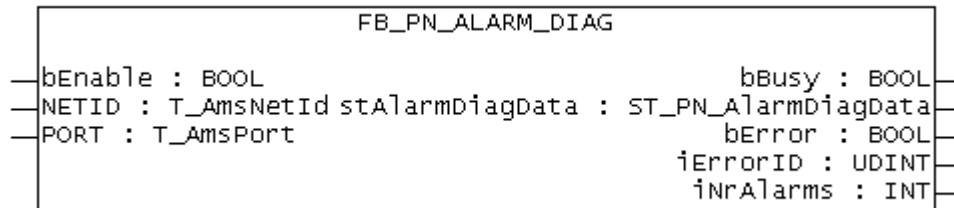

Fig. 58: FUNCTION_BLOCK FB_PN_ALARM_DIAG

Diagnosis alarms can be read out using this function block. Each instance of this function block makes a PLC input available ("PnIoBoxDiag"). This input must be linked to the "PnIoBoxDiag" input of the device that is to be evaluated. After successful reading of the diagnosis alarms/warnings, the alarm status of the device is reset. The function block must be called once for each PROFINET device. A running index (iNrAlarms) indicates how many diagnosis alarms have been read from the buffer.

VAR_INPUT

```
VAR_INPUT
  bEnable : BOOL;
  NETID   : T_AmsNetId; (* AMS Net ID from Controller *)
  PORT    : T_AmsPort; (* Port used by Controller to communicate with Device *)
END_VAR
```

bEnable: Activation of the function block

NETID: AMS Net ID of the controller

PORT: Port via which the controller communicates with the device (port = Device ID + 1000 hex)

VAR_OUTPUT

```
VAR_OUTPUT
  bBusy      : BOOL;
  stAlarmDiagData : ST_PN_AlarmDiagData;
  bError     : BOOL;
  iErrorID   : UDINT;
  iNrAlarms  : INT;
END_VAR
```

bBusy: When the function block is activated this output is set. It remains set until a feedback is received. While Busy = TRUE, no new command will be accepted at the inputs.

stAlarmDiagData: Diagnosis messages are output via this structure. An alarm is output via the structure in each cycle as long as the status bit [0x0010 = at least one AlarmCR got a diagnosis alarm] is present at the PLC input.

bError: If an error should occur during the transmission of the command, this output is set after the *bBusy* output has been reset.

iErrorID: Supplies an ADS error number when the output *bError* is set.

iNrAlarms: Number of alarms last read out.

VAR

```
VAR
  PnIoBoxDiag AT %I* : WORD; (*Hardware Input*)
END_VAR
```

PnIoBoxDiag : Hardware input: this variable must be linked to the PROFINET device. A change of state of this variable indicates to the PLC program that there are new diagnosis alarms in the linked PROFINET device.

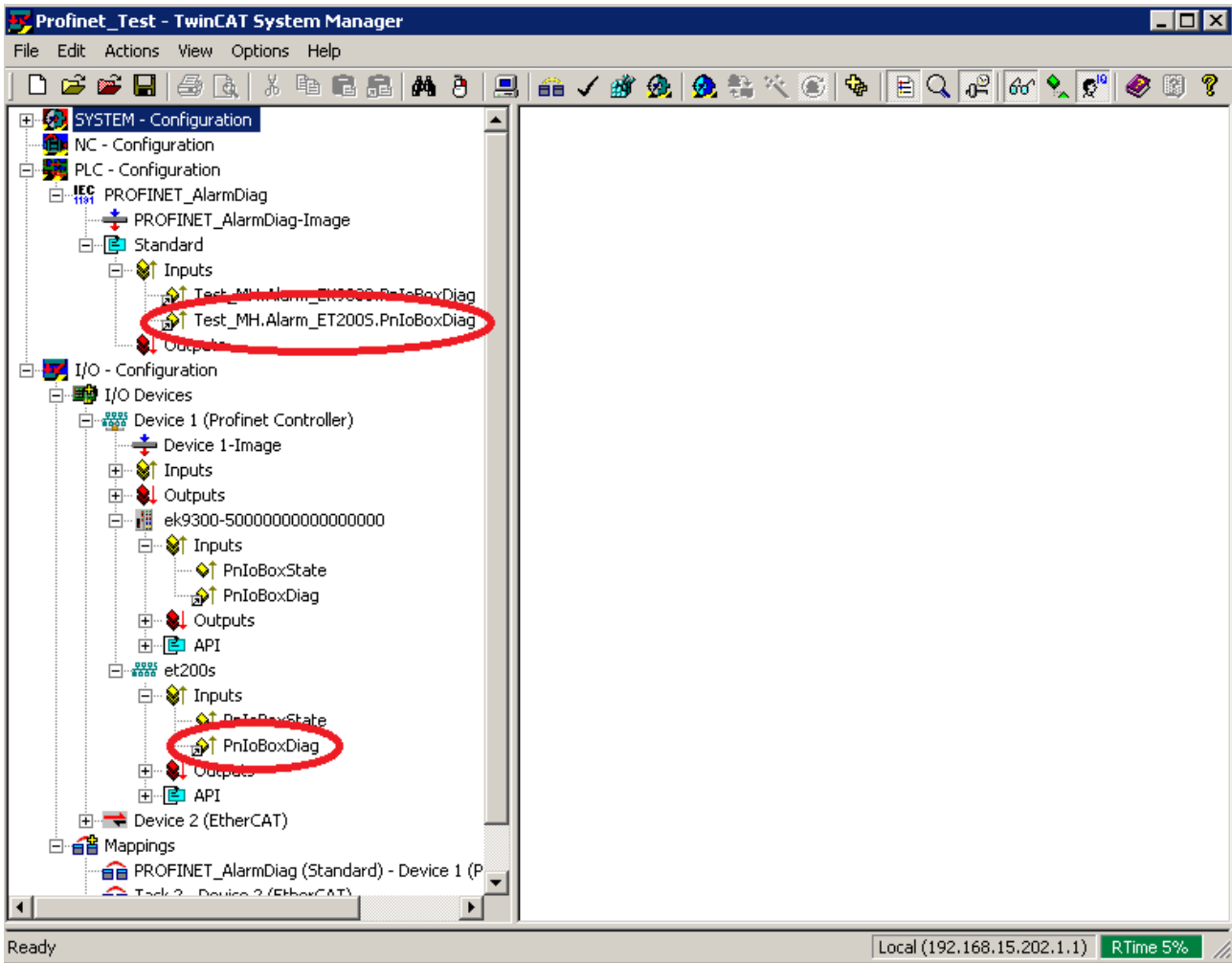

Fig. 59: Linking of the variables in the TwinCAT tree

Development environment	Target platform	PLC libraries to be linked
TwinCAT v2.11.0 R3	PC or CX (x86, ARM)	TcProfinetDiag.Lib

6.3 Data Structures

6.3.1 I&M

6.3.1.1 str_SW_Rec

The data structure **str_IM_0xAFF0** maps the structure of the I&M0 frame in the PLC. Which contains information that is permanently stored in PROFINET devices.

```

TYPE str_IM_0xAFF0 :
STRUCT
  nBlockTyp      : WORD;
  nBlockLen      : WORD;
  nBlockVersion  : WORD;
  nVendorID      : WORD;
  cOrderID       : STRING(21);
  cSerialNumber  : STRING(17);
  nHW_Rev        : WORD;
  strSW_Rev      : str_SW_Rec;
  nRevCount      : WORD;
  nProfileID     : WORD;
  nProfileSpecType : WORD;
  arIM_Version   : ARRAY[0..1] OF BYTE;
  nSupport       : WORD;
END_STRUCT
END_TYPE

```

The data structure **str_SW_REC** contains the software version of the PROFINET device.

```

TYPE str_SW_Rec :
STRUCT
  cSWRevPrefix   : STRING(2);
  nSWRevFuncEnhance : BYTE;
  nSWRevBugFix   : BYTE;
  nSWRevIntCha   : BYTE;
END_STRUCT
END_TYPE

```

6.3.1.2 str_IM_0xAFF1

The data structure **str_IM_0xAFF1** maps the structure of the I&M1 frame in the PLC. This structure is used both for writing to, and for reading from a PROFINET device.

```

TYPE str_IM_0xAFF1 :
STRUCT
  nBlockTyp      : WORD;
  nBlockLen      : WORD;
  nBlockVersion  : WORD;
  st_IM_TagFunction : STRING(32);
  st_IM_TagLocation : STRING(22);
END_STRUCT
END_TYPE

```

6.3.1.3 str_IM_0xAFF2

The data structure **str_IM_0xAFF2** maps the structure of the I&M2 frame in the PLC. This structure is used both for writing to, and for reading from a PROFINET device.

```
TYPE str_IM_0xAFF1 :  
STRUCT  
  nBlockTyp      : WORD;  
  nBlockLen      : WORD;  
  nBlockVersion  : WORD;  
  st_IM_Date     : STRING(16);  
END_STRUCT  
END_TYPE
```

6.3.1.4 str_IM_0xAFF3

The data structure **str_IM_0xAFF3** maps the structure of the I&M3 frame in the PLC. This structure is used both for writing to, and for reading from a PROFINET device.

```
TYPE str_IM_0xAFF3 :  
STRUCT  
  nBlockTyp      : WORD;  
  nBlockLen      : WORD;  
  nBlockVersion  : WORD;  
  st_IM_Descriptor : STRING(54)  
END_STRUCT  
END_TYPE
```

6.3.1.5 str_IM_0xAFF4

The data structure **str_IM_0xAFF4** maps the structure of the I&M4 frame in the PLC. This structure is used both for writing to, and for reading from a PROFINET device.

```
TYPE str_IM_0xAFF3 :  
STRUCT  
  nBlockTyp      : WORD;  
  nBlockLen      : WORD;  
  nBlockVersion  : WORD;  
  st_IM_Signatur : STRING(54)  
END_STRUCT  
END_TYPE
```

6.3.2 Port

6.3.2.1 str_GetPortStatistic

All statistical information of a device is represented in the data structure **str_GetPortStatistic**.

```
TYPE str_GetPortStatistic :  
  
STRUCT  
    Speed          : DWORD;  
    PhyMAC         : STRING(50);  
    OperatingStatus : STRING(16);  
    RxOctets       : DWORD;  
    RxUniCastPackets : DWORD;  
    RxBadPackets   : DWORD;  
    RxDroppedFrames : DWORD;  
    RxUnknownProtocol : DWORD;  
    TxOctets       : DWORD;  
    TxUniCastPackets : DWORD;  
    TxBadPackets   : DWORD;  
    TxDroppedPackets : DWORD;  
END_STRUCT  
  
END_TYPE
```

6.3.2.2 str_PortDiag

All port diagnostic information is represented in the data structure **str_PortDiag**.

```
TYPE str_PortDiag :
```

```
STRUCT
  PortId          : STRING(128);
  PortDescription : STRING(128);
  SystemName      : STRING(128);
  SystemDescription : STRING(128);
  ChassisId       : STRING(128);
END_STRUCT
END_TYPE
```

6.3.3 AlarmDiag

6.3.3.1 ST_PN_DiagMessage

The data structure **ST_PN_DiagMessage** contains the complete data stream of a diagnostic message that is sent by a PROFINET on request. This data stream is evaluated in the **FB_PN_ALARM_DIAG** function block and is copied to a readable structure.

```
TYPE ST_PN_DiagMessage :
```

```
STRUCT
  nFlags      : WORD;
  nTextID     : WORD;
  TimeStamp  : ARRAY[0..7] OF BYTE;
  nData       : ARRAY[0..299] OF BYTE;
END_STRUCT
END_TYPE
```

6.3.3.2 ST_PN_Diag

The data structure **ST_PN_Diag** contains a diagnostic message from a terminal that is connected via a PN device and a controller.

```
TYPE str_PortDiag :
```

```
STRUCT
  strTimeStamp      : ARRAY[0..7] OF BYTE;
  nAPI              : DWORD;
  nSlot            : WORD;
  nSubSlot         : WORD;
  nAlarmType       : WORD;
  nAlarmSpecifier  : WORD;
  nUserStructIdentifier : WORD;
  nChannelNumber   : WORD;
  nChannelErrorTyp : WORD;
  nChannelProperties : WORD;
  nExtChannelErrorTyp : WORD;
  arSpare          : ARRAY [1..9] OF WORD;
  arUserSpecificData : ARRAY [0..19] OF BYTE;
END_STRUCT
END_TYPE
```

The information content of the structure corresponds to that of the Diag History, which is displayed in the system manager.

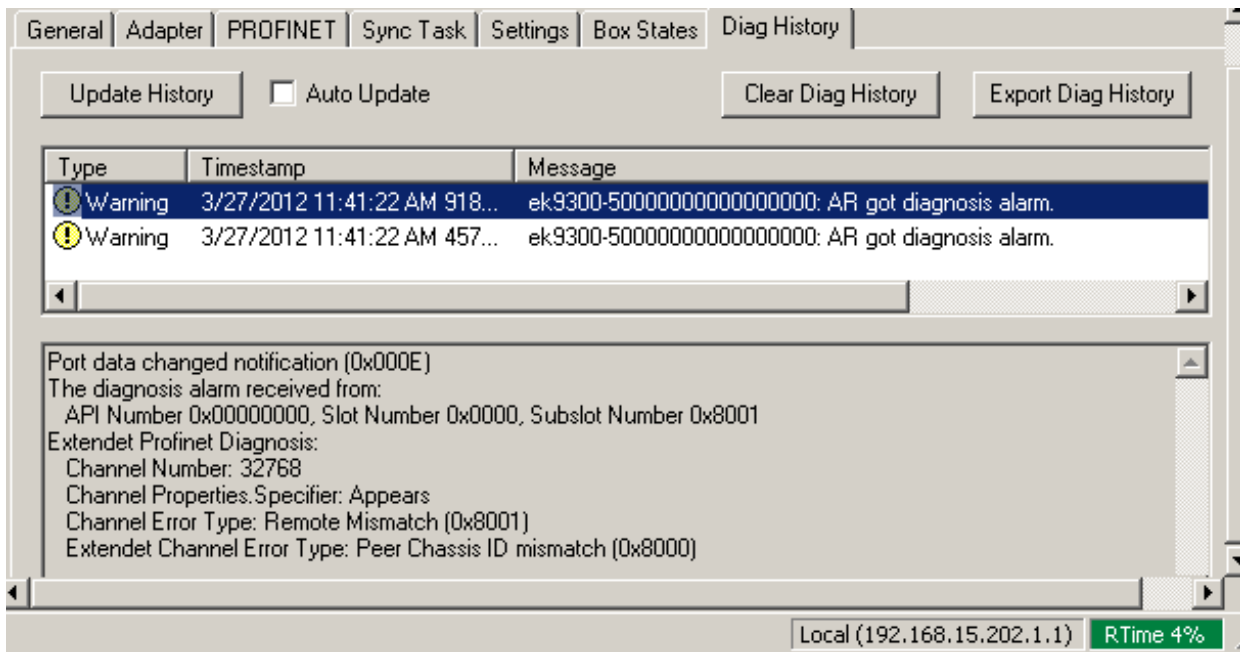

Fig. 60: "Diag History" tab

6.3.3.3 ST_PN_AlarmDiagData

The data structure **ST_PN_AlarmDiagData** contains the alarm diagnosis data record read from a device, including a time stamp that indicates when the event occurred and a flag that indicates that 'user-specific' data are present.

```

TYPE ST_PN_AlarmDiagData :
STRUCT
  ST_TimeStamp      : TIMESTRUCT;
  sNameOfStation    : STRING(20);
  ST_Diag           : ST_PN_Diag [P_90];
  bUserSpecData     : BOOL;
END_STRUCT
END_TYPE
    
```

6.3.4 Enumeration types for PROFINET alarms

E_PN_ALARM_TYP

The enumeration type **E_PN_ALARM_TYP** lists all PROFINET communication alarms.

```

TYPE E_PN_ALARM_TYP :
(
  PN_ALARM_RESERVE                :=0,
  PN_ALARM_DIAGNOSE_APPEARS      :=1,
  PN_ALARM_PROCESS                 :=2,
  PN_ALARM_PULL                   :=3,
  PN_ALARM_PLUG                   :=4,
  PN_ALARM_STATUS                 :=5,
  PN_ALARM_UPDATE                 :=6,
  PN_ALARM_REDUNDANCY             :=7,
  PN_ALARM_Controlled_by_Supervisor :=8,
  PN_ALARM_Released               :=9,
  PN_ALARM_Plug_Wrong_Submodule   :=16#A,
  PN_ALARM_Diagnosis_Disappears   :=16#B,
  PN_ALARM_Multicast_Communication_Mismatch :=16#C,
  PN_ALARM_Multicast              :=16#D,
  PN_ALARM_STATUS_                :=16#E,
  PN_ALARM_Sync_                  :=16#F,
  PN_ALARM_Isochronous_Mode_Problem_Notification :=16#10
);
END_TYPE
    
```

7 Appendix

7.1 FAQ

The following information answers frequently asked questions and gives hints for the configuration of the PROFINET system. If these are not observed, undesired behavior may occur. Here you will find approaches to diagnostics.

7.1.1 Device description file (GSDML) / DAP (DeviceAccessPoint)

Device description file (GSDML) / DAP (DeviceAccessPoint)

- Is the GSDML available on the system?
- Do the versions of both systems match?
 - It is recommended to use the same GSDML/DAP versions on both systems.
 - Is the latest version used?
- Is the GSDML in the correct path?
 - TwinCAT 2: TwinCAT2: C:\TwinCAT\lo\ProfiNet
 - TwinCAT 3: C:\TwinCAT\3.1\Config\lo\Profinet
- Is the correct GSDML used?
 - Version
 - It may be necessary to contact the vendor/manufacturer or search for the appropriate GSDML on the vendor's website.
- Where can I find GSDML files?
 - From Beckhoff products the GSDML files are usually delivered with the installation of TwinCAT.
 - On the [Beckhoff website](#), use the "Download Finder" and its filter options for this purpose

The screenshot shows the Beckhoff website's 'Download finder' page. The page is titled 'Download finder' and includes a navigation menu with 'Company', 'Products', 'Industries', and 'Support'. A search bar is located in the top right corner. The main content area features a 'Download finder' button highlighted in a red box. Below the button, there is a section titled 'Download finder' with a star icon. The text states: 'Our download finder contains all the files that we offer you for downloading: from our application reports and technical documents to the configuration files. The downloads are available in various formats. On request, we will be glad to send you our catalogs and brochures in printed form. Please use our [online order form](#) to specify your requirements.' Below this text, there are four columns of resources, each with a representative image and a 'Learn more' link:

- Application notes**: The Application Notes contain application examples for our products. [Learn more →](#)
- Data sheets**: We offer you PDF data sheets for our accessory products such as cables, lines, connectors, etc. [Learn more →](#)
- Information media**: Beckhoff provides a great deal of information media, which can be downloaded as PDF files. [Learn more →](#)
- Configuration files**: Here you will find the appropriate configuration files for various bus systems in different file formats, such as EDS or GSD files. [Learn more →](#)

Fig. 61: Website Download finder

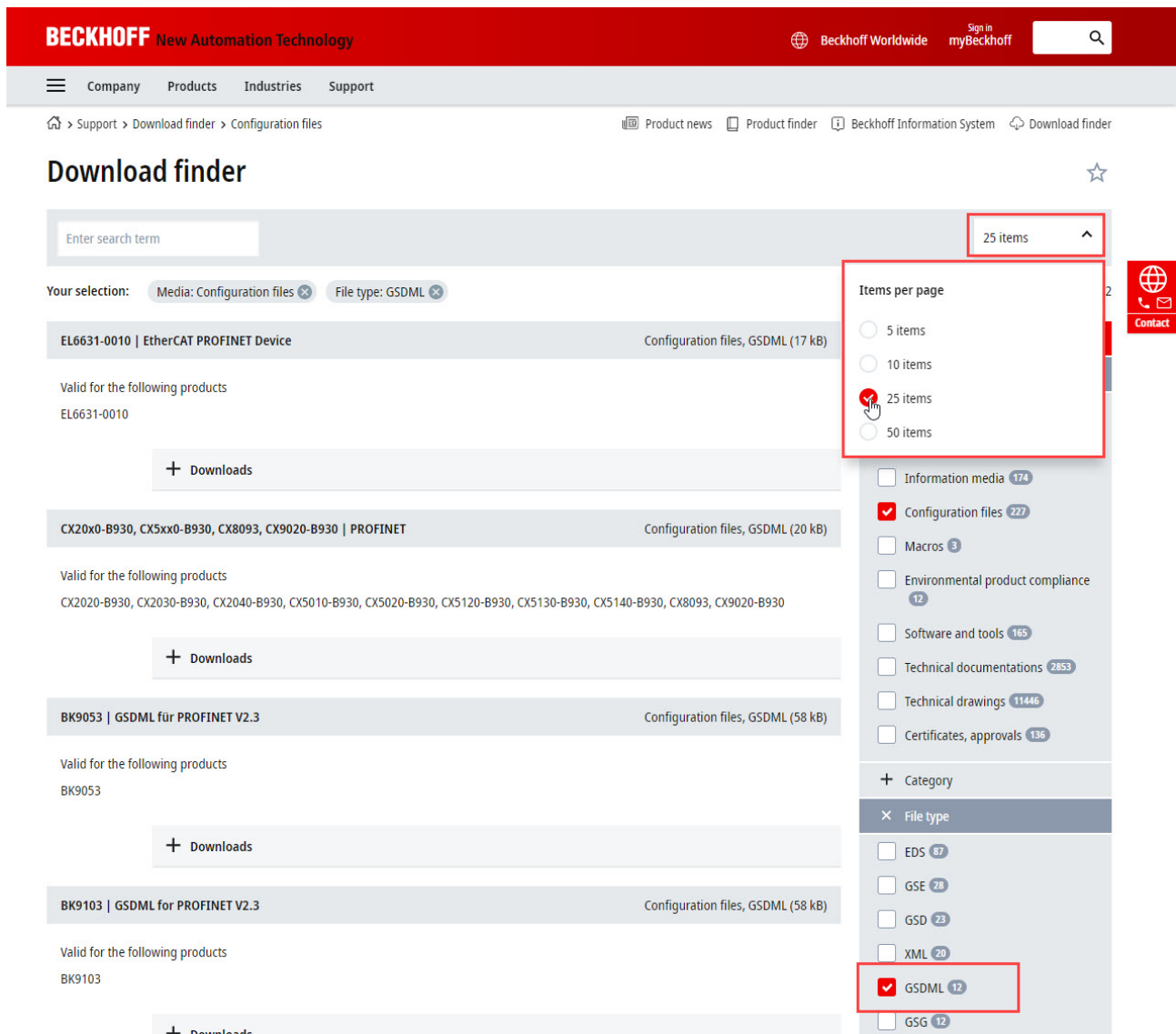

Fig. 62: Website Download finder (filtered)

- For products from other suppliers/manufacturers, the supplier must be contacted or the GSDML files can be downloaded from the website.

7.1.2 Task configuration

Task configuration

- Has a free-running task been created?
 - Or a "special sync task" used?
- Cycle time to base 2?
 - 1ms, 2ms, 4ms, 8ms,

The screenshot shows a software configuration window with several tabs: General, Adapter, PROFINET, Sync Task, Diag History, and Diagnosis. The 'Sync Task' tab is active. Under the 'Settings' section, the 'Special Sync Task' radio button is selected. Below it, a dropdown menu shows 'Task_PROFINET' and a 'Create new I/O Task' button is visible. The 'Sync Task' section contains the following fields: 'Name' is 'Task_PROFINET', 'Cycle ticks' is '1' (with a multiplier of '1.000 ms'), and 'Priority' is '1'. There is also an unchecked checkbox for 'Adjustable by Protocol'.

Fig. 63: Setting "Special Sync Task"

- Further notes in chapter [Sync Task](#)

7.1.3 EL663x-00x0 EtherCAT Terminals

EL663x-00x0 EtherCAT Terminals

- Was the correct terminal used?
 - EL663x-0000 cannot be used as device
 - EL6631-0010 cannot be used as controller

EL663x-00x0 EtherCAT Terminals

- Was the correct terminal used?
 - EL663x-0000 cannot be used as device
 - EL6631-0010 cannot be used as controller

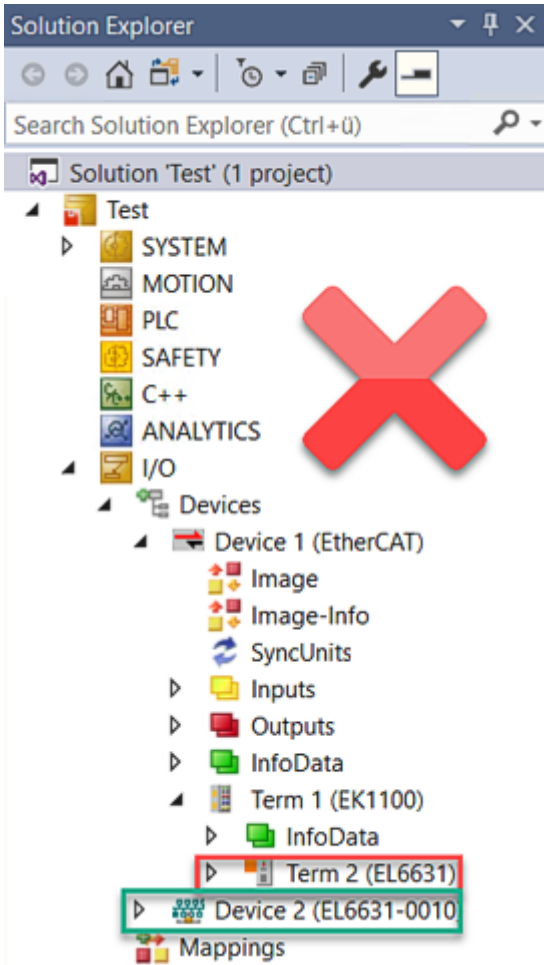

Fig. 64: Wrong configuration

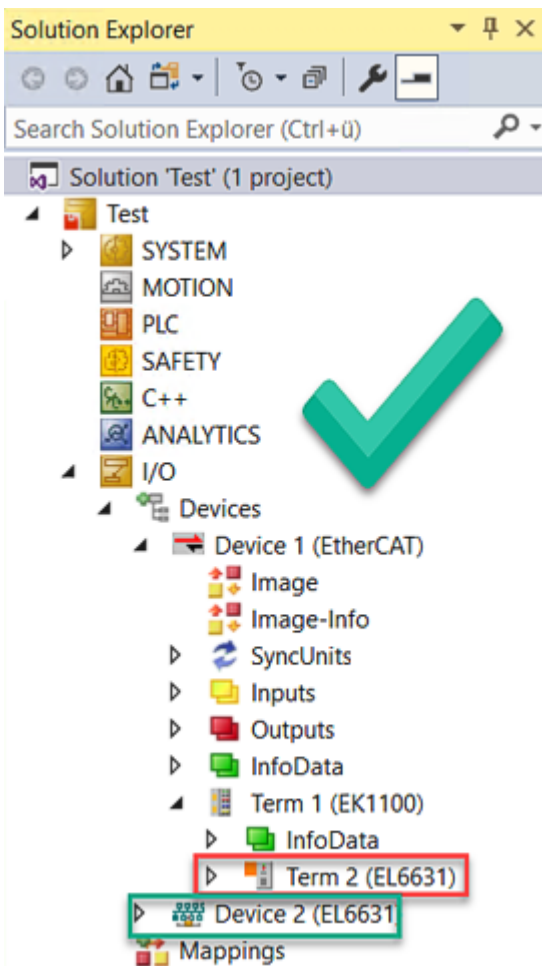

Fig. 65: Correct configuration

- EtherCAT diagnostics
 - EtherCAT state = Operational (OP)
 - WcState = 0 (Data valid)
- EtherCAT diagnostics
 - EtherCAT state = Operational (OP)
 - WcState = 0 (Data valid)

7.1.4 BoxStates of the PROFINET devices

BoxStates of the PROFINET devices

- Communication established?
 - See [Box States](#)

7.1.5 Diagnostic status under TIA

- I get a message that the installed firmware is not identical to the version of the configured firmware, what should I do?
 - If this message appears under the TIA software (see illustration), it can be ignored. The products are always downward compatible, i.e. the old GSDML file can still be used with newer software without having to update it. There is no technical reason to take action here.

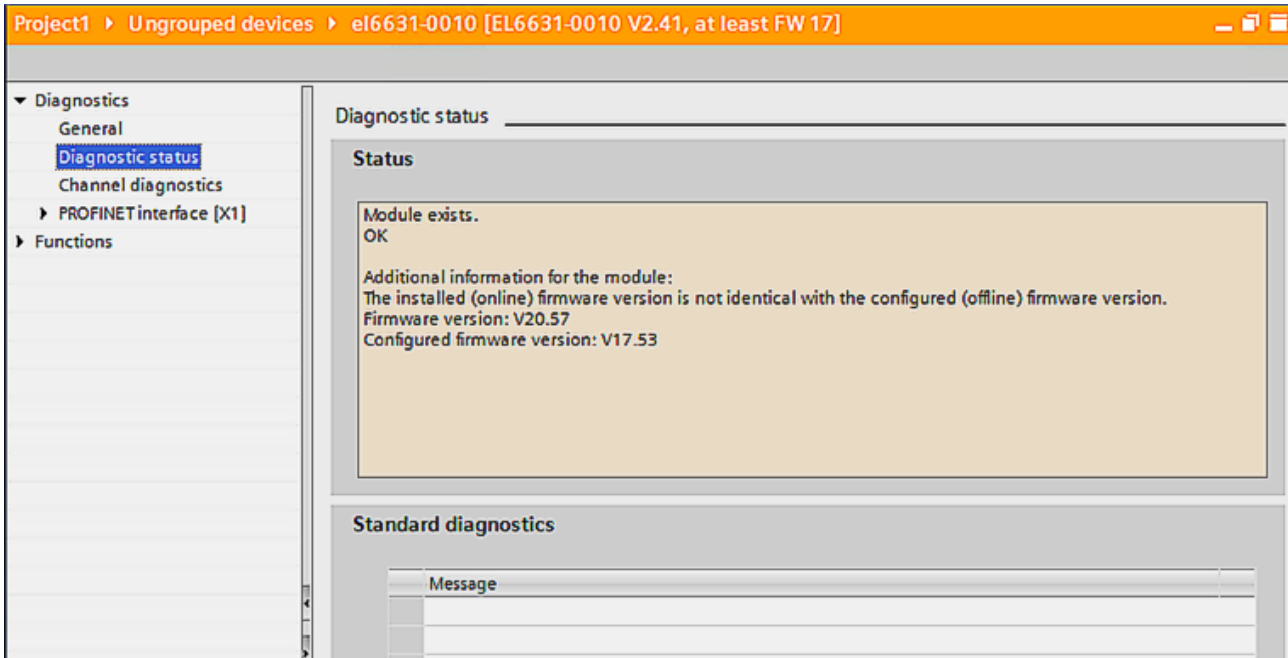

Fig. 66: Note on the firmware in Diagnostic Status

7.2 EtherCAT AL Status Codes

For detailed information please refer to the [EtherCAT system description](#).

7.3 Firmware compatibility

Beckhoff EtherCAT devices are delivered with the latest available firmware version. Compatibility of firmware and hardware is mandatory; not every combination ensures compatibility. The overview below shows the hardware versions on which a firmware can be operated.

Note

- It is recommended to use the newest possible firmware for the respective hardware
- Beckhoff is not under any obligation to provide customers with free firmware updates for delivered products.

NOTICE			
Risk of damage to the device!			
Pay attention to the instructions for firmware updates on the separate page [▶ 100] .			
If a device is placed in BOOTSTRAP mode for a firmware update, it does not check when downloading whether the new firmware is suitable.			
This can result in damage to the device! Therefore, always make sure that the firmware is suitable for the hardware version!			

EL6631			
Hardware (HW)	Firmware	Revision no.	Date of release
02-17*	01 (V00.08)	EL6631-0000-0016	2012/04
		EL6631-0000-0017	2012/10
	02	EL6631-0000-0018	2013/05
	03		2014/12
	04		2015/10
	05		2017/01
	06		2017/12
	07		2018/08
	08		2019/12
	09		2021/04
	10		2022/01
11*		2022/12	

EL6632			
Hardware (HW)	Firmware	Revision no.	Date of release
02-07	00 (V00.26)	EL6632-0000-0016	BETA Version
	01	EL6632-0000-0017	2014/11
08-16*	02		2015/10
	03		2016/03
	04		2017/03
	05		2018/08
	06*		2021/10

*) This is the current compatible firmware/hardware version at the time of the preparing this documentation. Check on the Beckhoff web page whether more up-to-date [documentation](#) is available.

7.4 Firmware Update EL/ES/EM/ELM/EP/EPP/ERPxxxx

This section describes the device update for Beckhoff EtherCAT slaves from the EL/ES, ELM, EM, EK, EP, EPP and ERP series. A firmware update should only be carried out after consultation with Beckhoff support.

NOTICE

Only use TwinCAT 3 software!

A firmware update of Beckhoff IO devices must only be performed with a TwinCAT 3 installation. It is recommended to build as up-to-date as possible, available for free download on the [Beckhoff website](#).

To update the firmware, TwinCAT can be operated in the so-called FreeRun mode, a paid license is not required.

The device to be updated can usually remain in the installation location, but TwinCAT has to be operated in the FreeRun. Please make sure that EtherCAT communication is trouble-free (no LostFrames etc.).

Other EtherCAT master software, such as the EtherCAT Configurator, should not be used, as they may not support the complexities of updating firmware, EEPROM and other device components.

Storage locations

An EtherCAT slave stores operating data in up to three locations:

- Each EtherCAT slave has a device description, consisting of identity (name, product code), timing specifications, communication settings, etc.
This device description (ESI; EtherCAT Slave Information) can be downloaded from the Beckhoff website in the download area as a [zip file](#) and used in EtherCAT masters for offline configuration, e.g. in TwinCAT.
Above all, each EtherCAT slave carries its device description (ESI) electronically readable in a local memory chip, the so-called **ESI EEPROM**. When the slave is switched on, this description is loaded locally in the slave and informs it of its communication configuration; on the other hand, the EtherCAT master can identify the slave in this way and, among other things, set up the EtherCAT communication accordingly.

NOTICE

Application-specific writing of the ESI-EEPROM

The ESI is developed by the device manufacturer according to ETG standard and released for the corresponding product.

- Meaning for the ESI file: Modification on the application side (i.e. by the user) is not permitted.
- Meaning for the ESI EEPROM: Even if a writeability is technically given, the ESI parts in the EEPROM and possibly still existing free memory areas must not be changed beyond the normal update process. Especially for cyclic memory processes (operating hours counter etc.), dedicated memory products such as EL6080 or IPC's own NOVDRAM must be used.

- Depending on functionality and performance EtherCAT slaves have one or several local controllers for processing I/O data. The corresponding program is the so-called **firmware** in *.efw format.
- In some EtherCAT slaves the EtherCAT communication may also be integrated in these controllers. In this case the controller is usually a so-called **FPGA** chip with *.rbf firmware.

Customers can access the data via the EtherCAT fieldbus and its communication mechanisms. Acyclic mailbox communication or register access to the ESC is used for updating or reading of these data.

The TwinCAT System Manager offers mechanisms for programming all three parts with new data, if the slave is set up for this purpose. Generally the slave does not check whether the new data are suitable, i.e. it may no longer be able to operate if the data are unsuitable.

Simplified update by bundle firmware

The update using so-called **bundle firmware** is more convenient: in this case the controller firmware and the ESI description are combined in a *.efw file; during the update both the firmware and the ESI are changed in the terminal. For this to happen it is necessary

- for the firmware to be in a packed format: recognizable by the file name, which also contains the revision number, e.g. ELxxxx-xxxx_REV0016_SW01.efw

- for password=1 to be entered in the download dialog. If password=0 (default setting) only the firmware update is carried out, without an ESI update.
- for the device to support this function. The function usually cannot be retrofitted; it is a component of many new developments from year of manufacture 2016.

Following the update, its success should be verified

- ESI/Revision: e.g. by means of an online scan in TwinCAT ConfigMode/FreeRun – this is a convenient way to determine the revision
- Firmware: e.g. by looking in the online CoE of the device

NOTICE

Risk of damage to the device!

- ✓ Note the following when downloading new device files

- Firmware downloads to an EtherCAT device must not be interrupted
- Flawless EtherCAT communication must be ensured. CRC errors or LostFrames must be avoided.
- The power supply must adequately dimensioned. The signal level must meet the specification.

⇒ In the event of malfunctions during the update process the EtherCAT device may become unusable and require re-commissioning by the manufacturer.

7.4.1 Device description ESI file/XML

NOTICE

Attention regarding update of the ESI description/EEPROM

Some slaves have stored calibration and configuration data from the production in the EEPROM. These are irretrievably overwritten during an update.

The ESI device description is stored locally on the slave and loaded on start-up. Each device description has a unique identifier consisting of slave name (9 characters/digits) and a revision number (4 digits). Each slave configured in the System Manager shows its identifier in the EtherCAT tab:

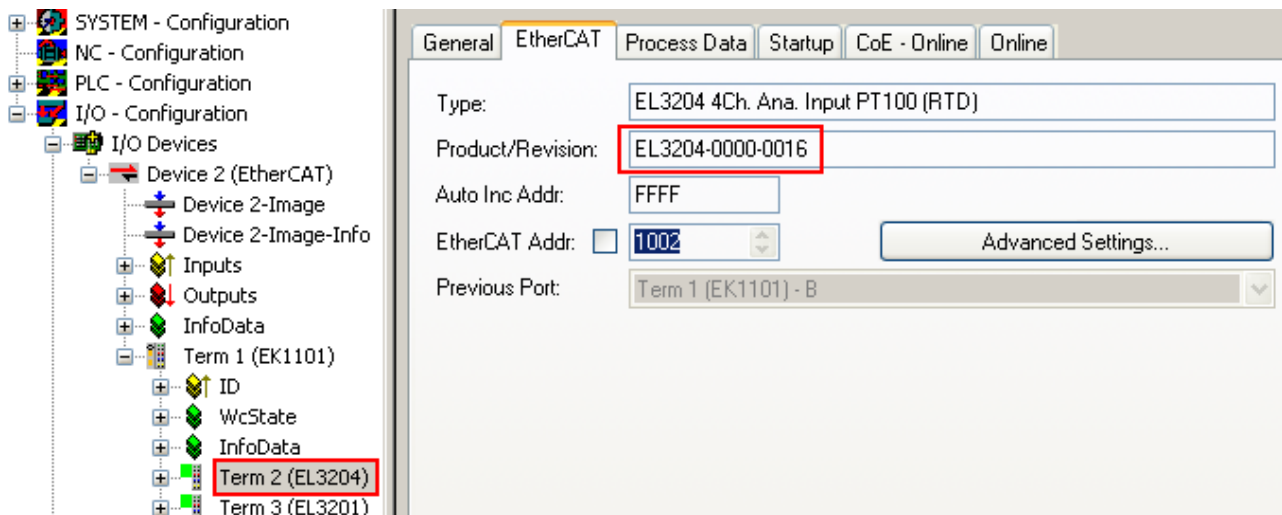

Fig. 67: Device identifier consisting of name EL3204-0000 and revision -0016

The configured identifier must be compatible with the actual device description used as hardware, i.e. the description which the slave has loaded on start-up (in this case EL3204). Normally the configured revision must be the same or lower than that actually present in the terminal network.

For further information on this, please refer to the [EtherCAT system documentation](#).

i Update of XML/ESI description

The device revision is closely linked to the firmware and hardware used. Incompatible combinations lead to malfunctions or even final shutdown of the device. Corresponding updates should only be carried out in consultation with Beckhoff support.

Display of ESI slave identifier

The simplest way to ascertain compliance of configured and actual device description is to scan the EtherCAT boxes in TwinCAT mode Config/FreeRun:

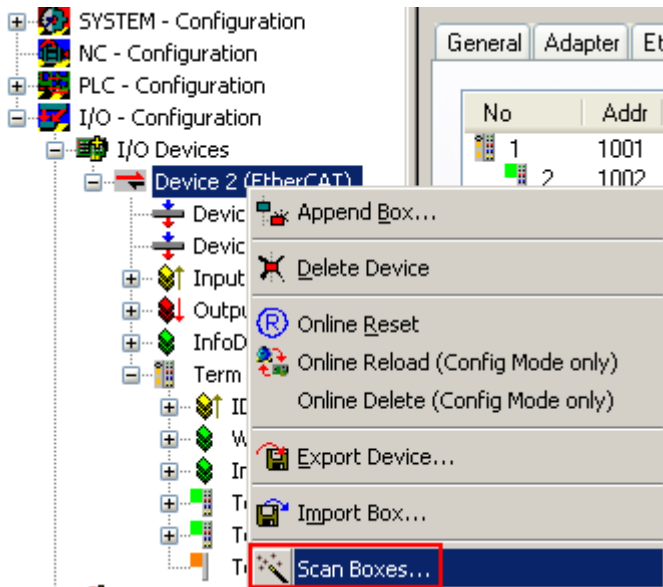

Fig. 68: Scan the subordinate field by right-clicking on the EtherCAT device

If the found field matches the configured field, the display shows



Fig. 69: Configuration is identical

otherwise a change dialog appears for entering the actual data in the configuration.

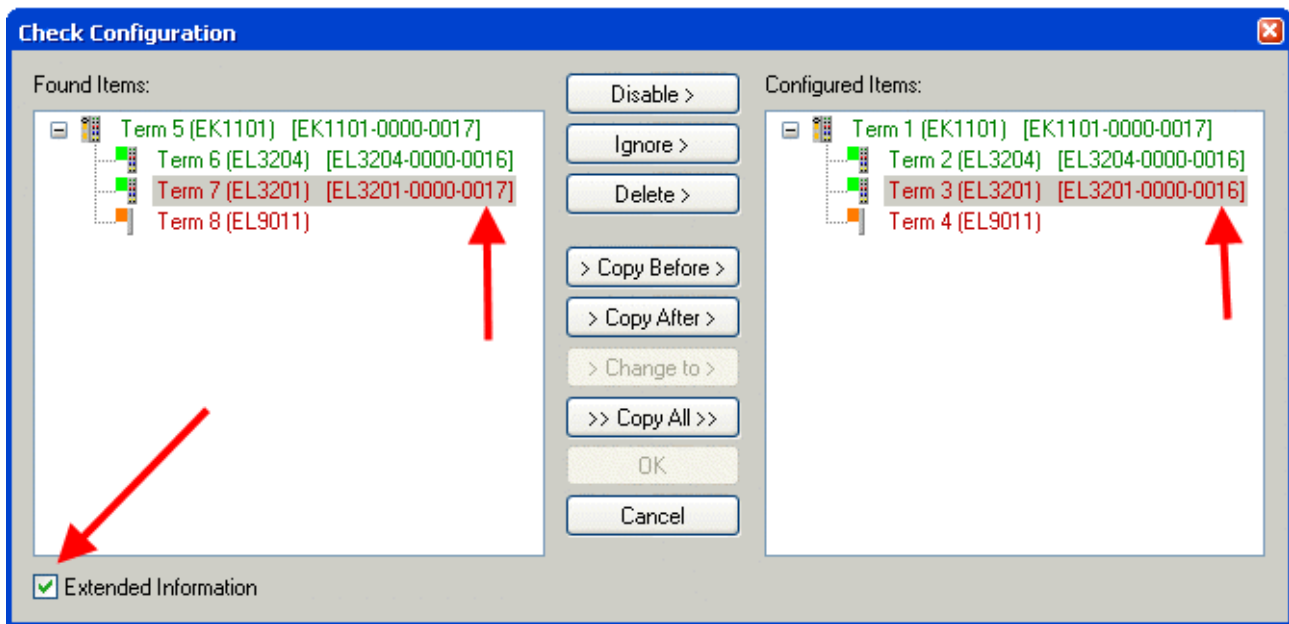

Fig. 70: Change dialog

In this example in Fig. *Change dialog*, an EL3201-0000-0017 was found, while an EL3201-0000-0016 was configured. In this case the configuration can be adapted with the *Copy Before* button. The *Extended Information* checkbox must be set in order to display the revision.

Changing the ESI slave identifier

The ESI/EEPROM identifier can be updated as follows under TwinCAT:

- Trouble-free EtherCAT communication must be established with the slave.
- The state of the slave is irrelevant.
- Right-clicking on the slave in the online display opens the *EEPROM Update* dialog, Fig. *EEPROM Update*

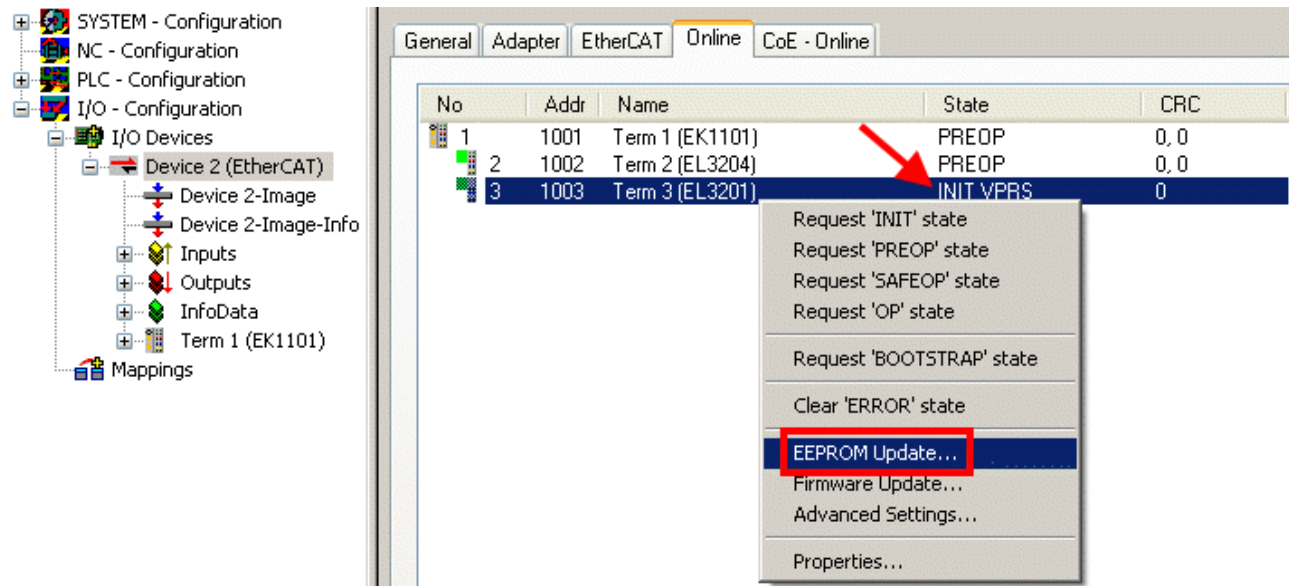

Fig. 71: EEPROM Update

The new ESI description is selected in the following dialog, see Fig. *Selecting the new ESI*. The checkbox *Show Hidden Devices* also displays older, normally hidden versions of a slave.

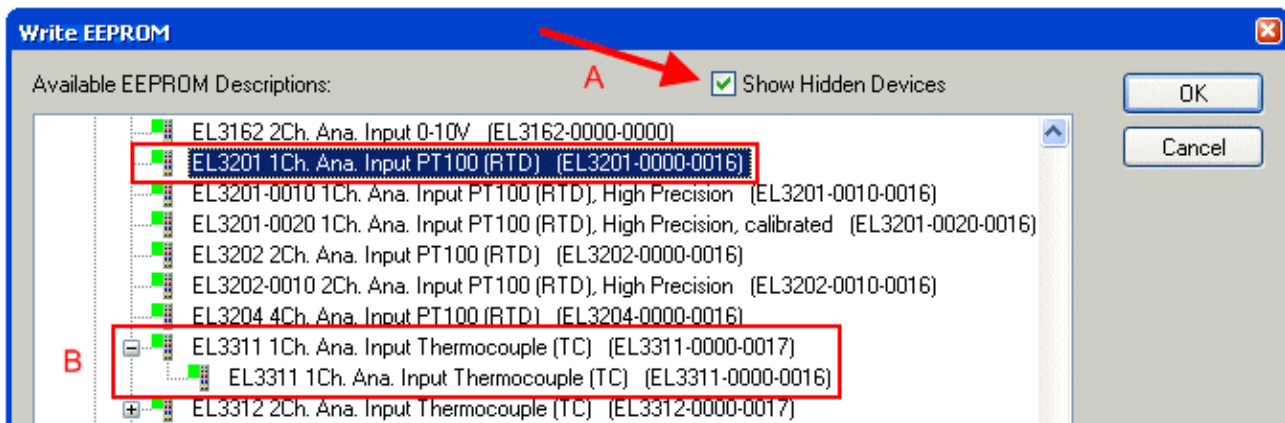

Fig. 72: Selecting the new ESI

A progress bar in the System Manager shows the progress. Data are first written, then verified.

i **The change only takes effect after a restart.**

Most EtherCAT devices read a modified ESI description immediately or after startup from the INIT. Some communication settings such as distributed clocks are only read during power-on. The EtherCAT slave therefore has to be switched off briefly in order for the change to take effect.

7.4.2 Firmware explanation

Determining the firmware version

Determining the version via the TwinCAT System Manager

The TwinCAT System Manager shows the version of the controller firmware if the master can access the slave online. Click on the E-Bus Terminal whose controller firmware you want to check (in the example terminal 2 (EL3204)) and select the tab *CoE Online* (CAN over EtherCAT).

i **CoE Online and Offline CoE**

Two CoE directories are available:

- **online:** This is offered in the EtherCAT slave by the controller, if the EtherCAT slave supports this. This CoE directory can only be displayed if a slave is connected and operational.
- **offline:** The EtherCAT Slave Information ESI/XML may contain the default content of the CoE. This CoE directory can only be displayed if it is included in the ESI (e.g. "Beckhoff EL5xxx.xml").

The Advanced button must be used for switching between the two views.

In Fig. *Display of EL3204 firmware version* the firmware version of the selected EL3204 is shown as 03 in CoE entry 0x100A.

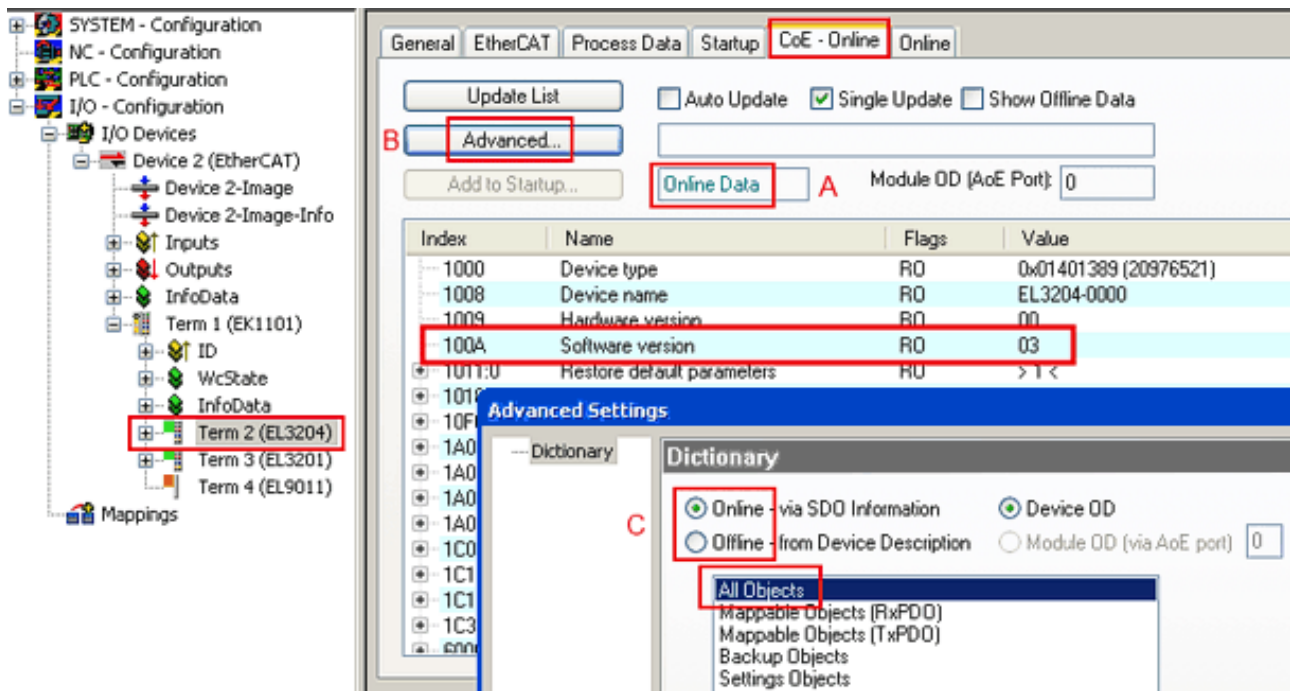

Fig. 73: Display of EL3204 firmware version

In (A) TwinCAT 2.11 shows that the Online CoE directory is currently displayed. If this is not the case, the Online directory can be loaded via the *Online* option in Advanced Settings (B) and double-clicking on *AllObjects*.

7.4.3 Updating controller firmware *.efw

● **CoE directory**

i The Online CoE directory is managed by the controller and stored in a dedicated EEPROM, which is generally not changed during a firmware update.

Switch to the *Online* tab to update the controller firmware of a slave, see Fig. *Firmware Update*.

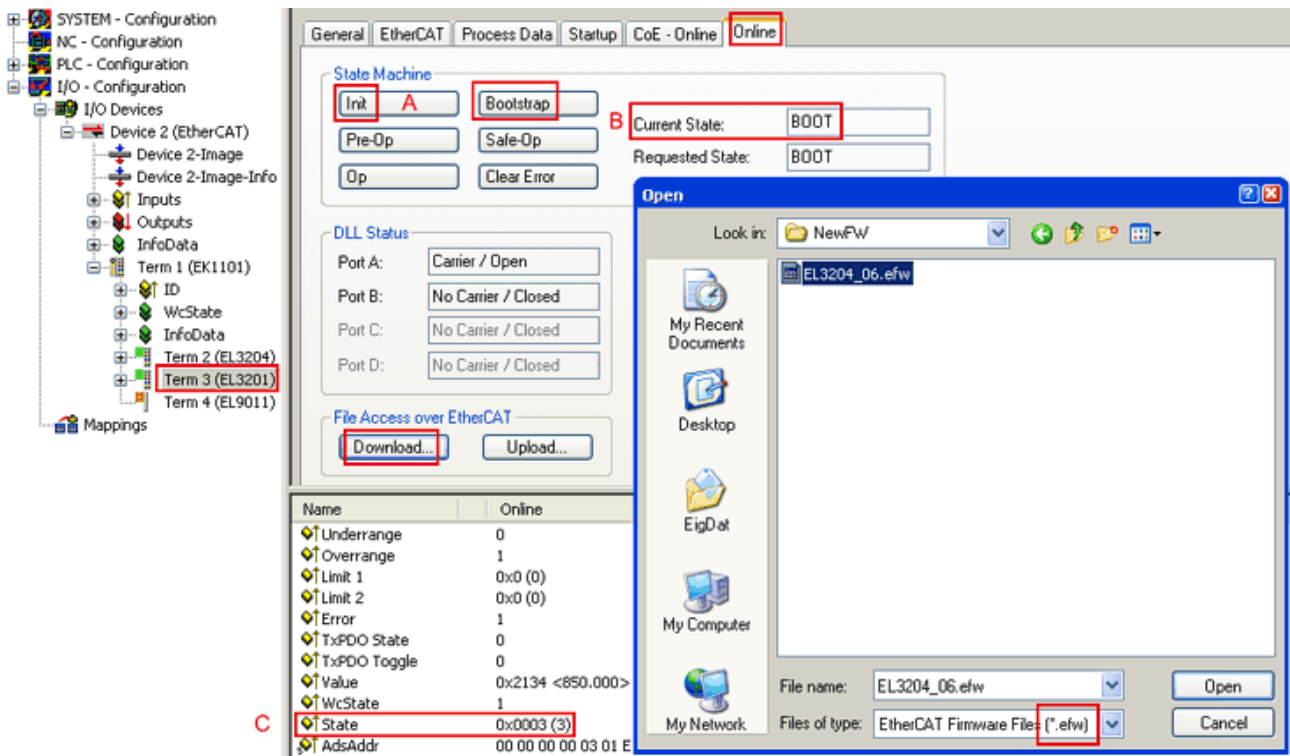
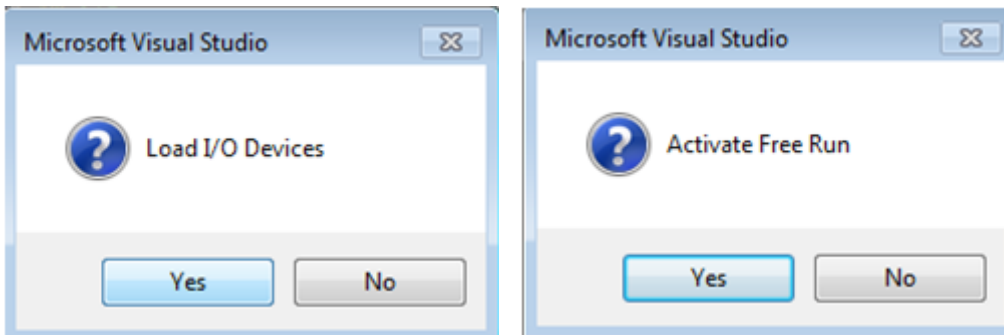

Fig. 74: Firmware Update

Proceed as follows, unless instructed otherwise by Beckhoff support. Valid for TwinCAT 2 and 3 as EtherCAT master.

- Switch TwinCAT system to ConfigMode/FreeRun with cycle time ≥ 1 ms (default in ConfigMode is 4 ms). A FW-Update during real time operation is not recommended.



- Switch EtherCAT Master to PreOP

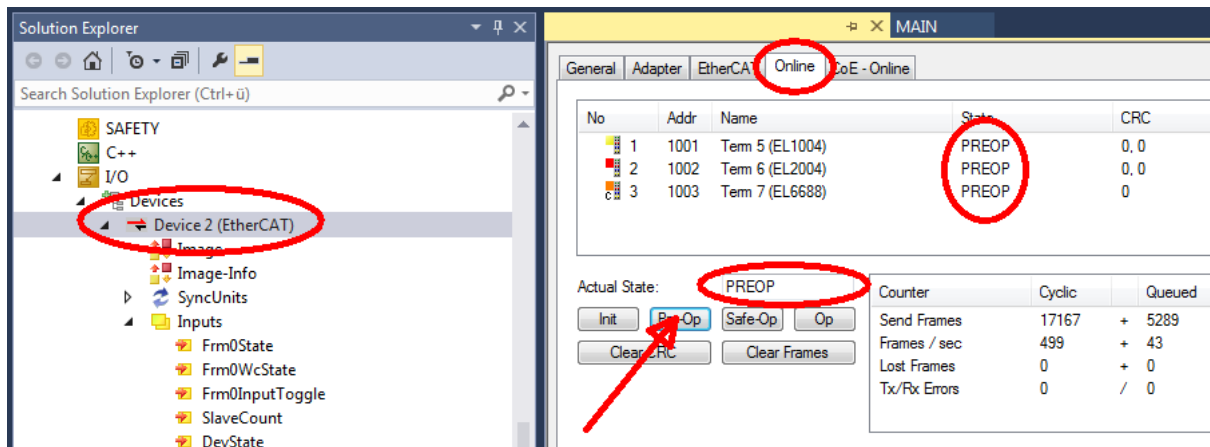

- Switch slave to INIT (A)
- Switch slave to BOOTSTRAP

- Check the current status (B, C)
- Download the new *efw file (wait until it ends). A password will not be necessary usually.

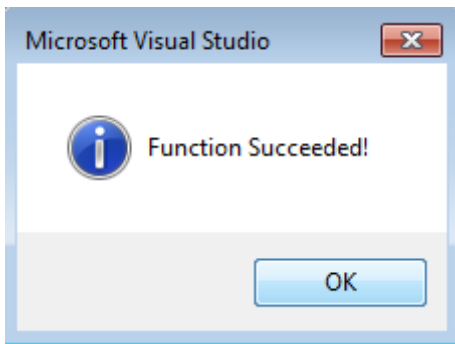

- After the download switch to INIT, then PreOP
- Switch off the slave briefly (don't pull under voltage!)
- Check within CoE 0x100A, if the FW status was correctly overtaken.

7.4.4 FPGA firmware *.rbf

If an FPGA chip deals with the EtherCAT communication an update may be accomplished via an *.rbf file.

- Controller firmware for processing I/O signals
- FPGA firmware for EtherCAT communication (only for terminals with FPGA)

The firmware version number included in the terminal serial number contains both firmware components. If one of these firmware components is modified this version number is updated.

Determining the version via the TwinCAT System Manager

The TwinCAT System Manager indicates the FPGA firmware version. Click on the Ethernet card of your EtherCAT strand (Device 2 in the example) and select the *Online* tab.

The *Reg:0002* column indicates the firmware version of the individual EtherCAT devices in hexadecimal and decimal representation.

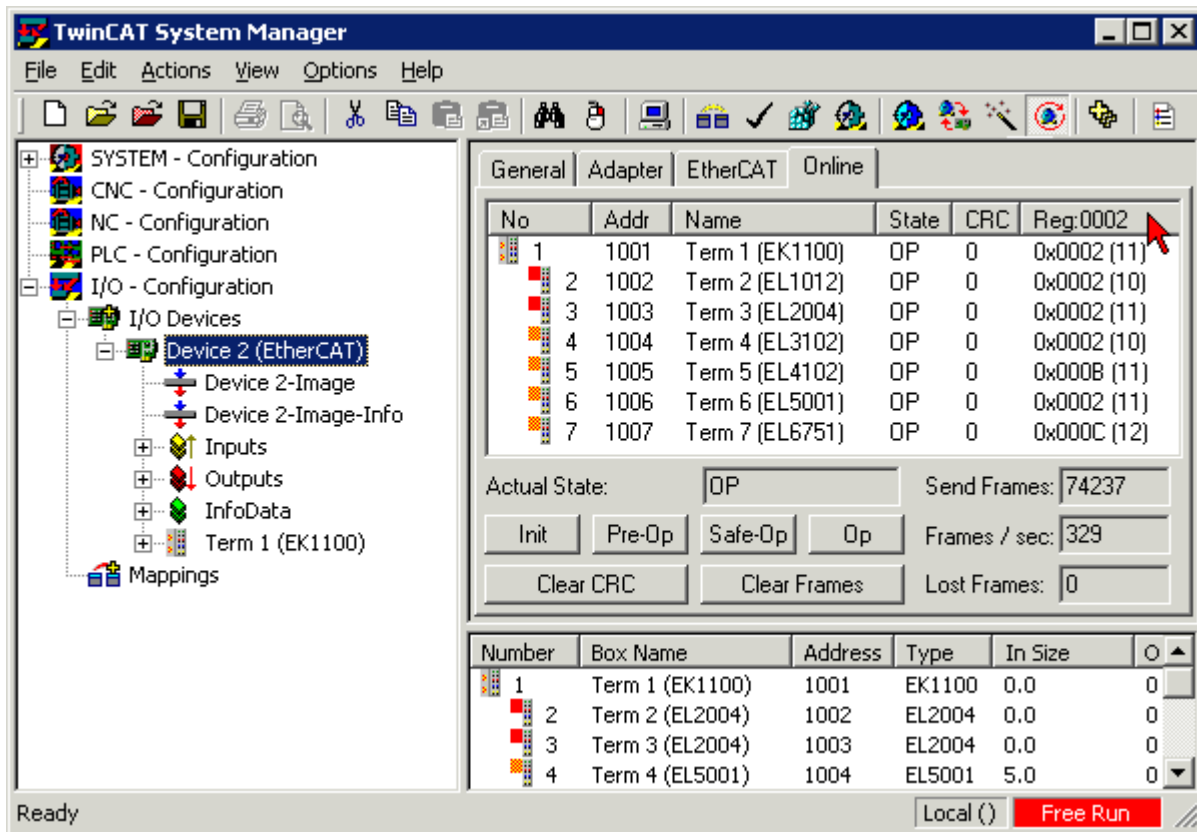
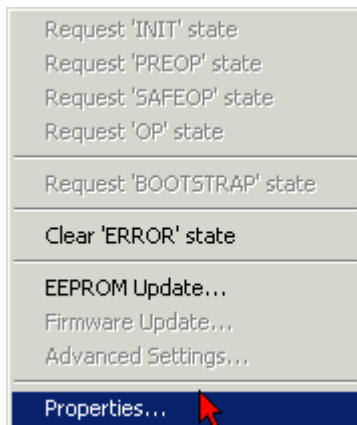

Fig. 75: FPGA firmware version definition

If the column *Reg:0002* is not displayed, right-click the table header and select *Properties* in the context menu.

Fig. 76: Context menu *Properties*

The *Advanced Settings* dialog appears where the columns to be displayed can be selected. Under *Diagnosis/Online View* select the *'0002 ETxxxx Build'* check box in order to activate the FPGA firmware version display.

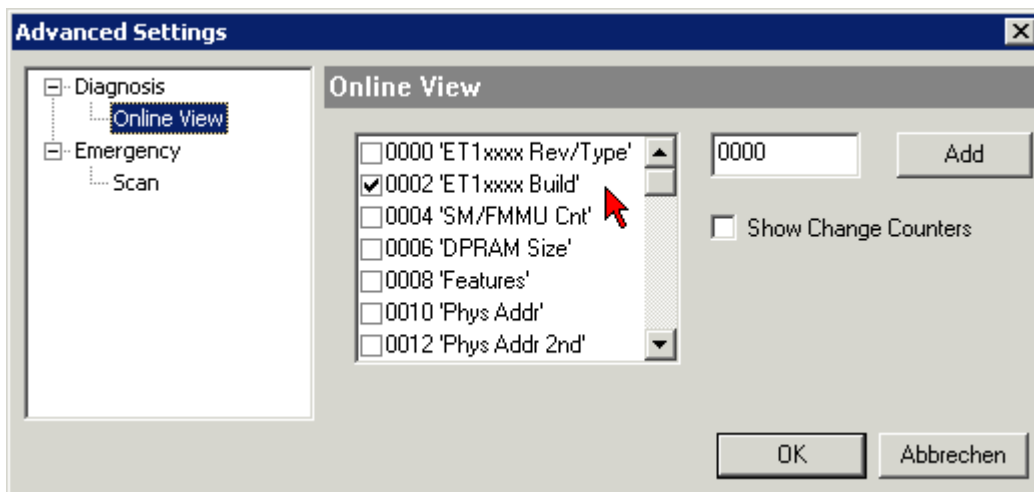

Fig. 77: Dialog *Advanced Settings*

Update

For updating the FPGA firmware

- of an EtherCAT coupler the coupler must have FPGA firmware version 11 or higher;
- of an E-Bus Terminal the terminal must have FPGA firmware version 10 or higher.

Older firmware versions can only be updated by the manufacturer!

Updating an EtherCAT device

The following sequence order have to be met if no other specifications are given (e.g. by the Beckhoff support):

- Switch TwinCAT system to ConfigMode/FreeRun with cycle time ≥ 1 ms (default in ConfigMode is 4 ms). A FW-Update during real time operation is not recommended.

- In the TwinCAT System Manager select the terminal for which the FPGA firmware is to be updated (in the example: Terminal 5: EL5001) and click the *Advanced Settings* button in the *EtherCAT* tab:

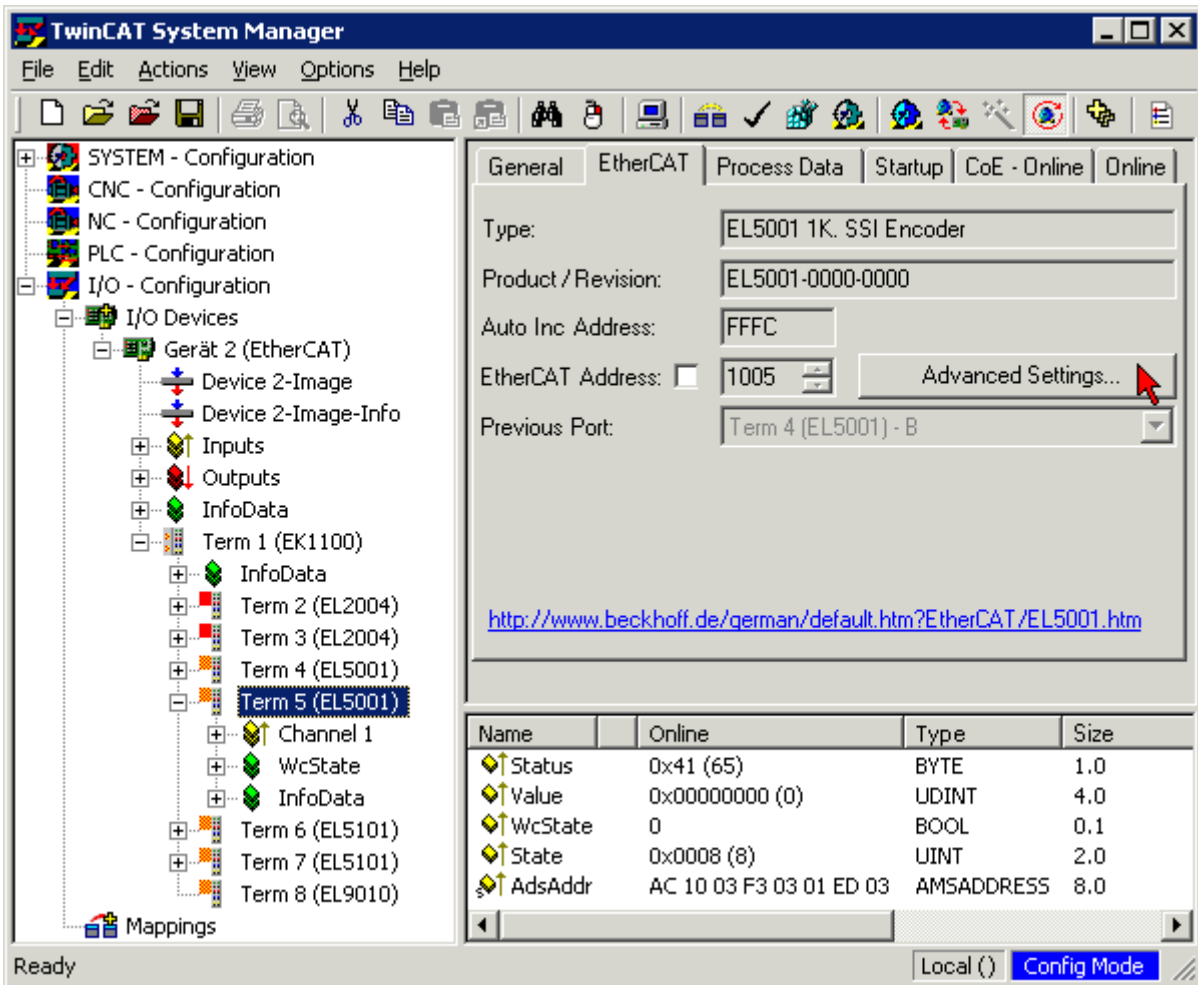

- The *Advanced Settings* dialog appears. Under *ESC Access/E²PROM/FPGA* click on *Write FPGA* button:

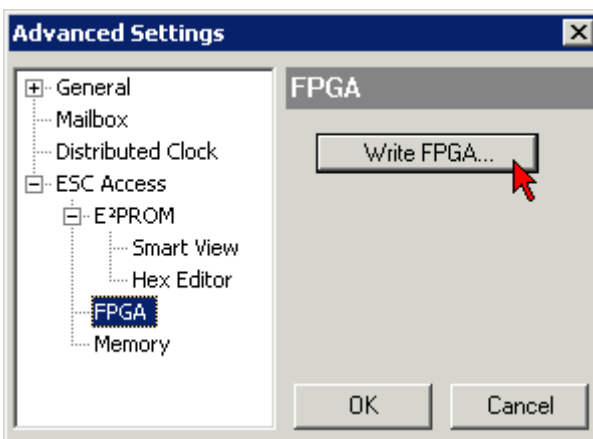

- Select the file (*.rbf) with the new FPGA firmware, and transfer it to the EtherCAT device:

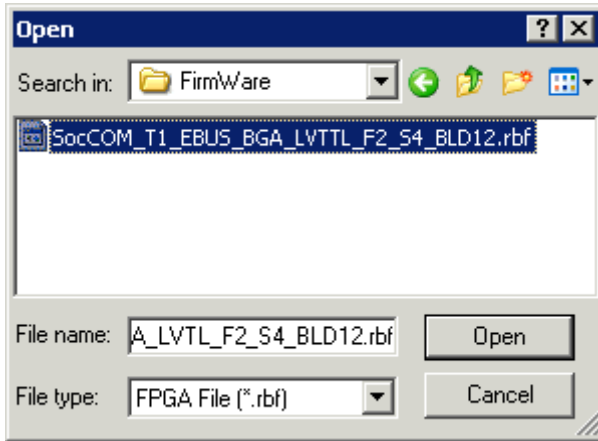

- Wait until download ends
- Switch slave current less for a short time (don't pull under voltage!). In order to activate the new FPGA firmware a restart (switching the power supply off and on again) of the EtherCAT device is required.
- Check the new FPGA status

NOTICE

Risk of damage to the device!

A download of firmware to an EtherCAT device must not be interrupted in any case! If you interrupt this process by switching off power supply or disconnecting the Ethernet link, the EtherCAT device can only be recommissioned by the manufacturer!

7.4.5 Simultaneous updating of several EtherCAT devices

The firmware and ESI descriptions of several devices can be updated simultaneously, provided the devices have the same firmware file/ESI.

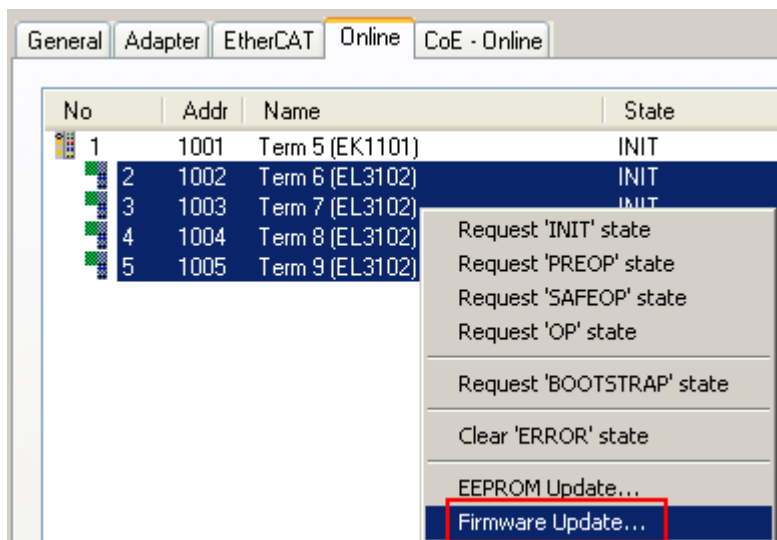

Fig. 78: Multiple selection and firmware update

Select the required slaves and carry out the firmware update in BOOTSTRAP mode as described above.

7.5 Support and Service

Beckhoff and their partners around the world offer comprehensive support and service, making available fast and competent assistance with all questions related to Beckhoff products and system solutions.

Beckhoff's branch offices and representatives

Please contact your Beckhoff branch office or representative for local support and service on Beckhoff products!

The addresses of Beckhoff's branch offices and representatives round the world can be found on her internet pages: www.beckhoff.com

You will also find further documentation for Beckhoff components there.

Support

The Beckhoff Support offers you comprehensive technical assistance, helping you not only with the application of individual Beckhoff products, but also with other, wide-ranging services:

- support
- design, programming and commissioning of complex automation systems
- and extensive training program for Beckhoff system components

Hotline: +49 5246 963 157
e-mail: support@beckhoff.com
web: www.beckhoff.com/support

Service

The Beckhoff Service Center supports you in all matters of after-sales service:

- on-site service
- repair service
- spare parts service
- hotline service

Hotline: +49 5246 963 460
e-mail: service@beckhoff.com
web: www.beckhoff.com/service

Headquarters Germany

Beckhoff Automation GmbH & Co. KG

Hülshorstweg 20
33415 Verl
Germany

Phone: +49 5246 963 0
e-mail: info@beckhoff.com
web: www.beckhoff.com

More Information:
www.beckhoff.com/EL6xxx

Beckhoff Automation GmbH & Co. KG
Hülshorstweg 20
33415 Verl
Germany
Phone: +49 5246 9630
info@beckhoff.com
www.beckhoff.com

