

Documentation | EN

# EPP9022-0060

EtherCAT P Box with diagnostics





# Table of contents

<b>1</b>	<b>Foreword</b> .....	<b>5</b>
1.1	Notes on the documentation .....	5
1.2	Safety instructions .....	6
1.3	Documentation issue status .....	7
<b>2</b>	<b>Product group: EtherCAT P Box modules</b> .....	<b>8</b>
<b>3</b>	<b>Product overview</b> .....	<b>9</b>
3.1	Introduction .....	9
3.2	Technical data .....	10
3.3	Scope of supply.....	12
3.4	Process image .....	13
<b>4</b>	<b>Mounting and connections</b> .....	<b>18</b>
4.1	Mounting .....	18
4.1.1	Dimensions .....	18
4.1.2	Fixing.....	19
4.1.3	Functional earth (FE) .....	19
4.2	Connections .....	20
4.2.1	Overview .....	20
4.2.2	EtherCAT P .....	21
4.2.3	Voltage measurement output.....	25
4.3	UL Requirements .....	26
4.4	Disposal .....	27
<b>5</b>	<b>Commissioning and configuration</b> .....	<b>28</b>
5.1	Integrating into a TwinCAT project.....	28
5.2	Measured values.....	29
5.2.1	Representation.....	29
5.2.2	Filter .....	30
5.3	Warning and error messages.....	31
5.3.1	Set the threshold values.....	32
5.3.2	Disabling messages .....	33
5.4	LEDs .....	34
5.4.1	LED filter .....	35
5.5	Restoring the delivery state.....	36
5.6	Decommissioning.....	37
<b>6</b>	<b>CoE parameters</b> .....	<b>38</b>
6.1	Introduction .....	38
6.1.1	Accessing CoE parameters with TwinCAT .....	38
6.1.2	Data format of CoE parameters .....	38
6.2	Object overview.....	39
6.3	Object description .....	40
6.3.1	Objects to be parameterized during commissioning .....	40
6.3.2	Profile-specific objects .....	42
6.3.3	Standard objects .....	44
<b>7</b>	<b>Appendix</b> .....	<b>46</b>

7.1	General operating conditions .....	46
7.2	Accessories .....	47
7.3	Version identification of EtherCAT devices .....	48
7.3.1	General notes on marking .....	48
7.3.2	Version identification of IP67 modules .....	49
7.3.3	Beckhoff Identification Code (BIC) .....	50
7.3.4	Electronic access to the BIC (eBIC) .....	52
7.4	Support and Service .....	54

# 1 Foreword

## 1.1 Notes on the documentation

### Intended audience

This description is only intended for the use of trained specialists in control and automation engineering who are familiar with the applicable national standards.

It is essential that the documentation and the following notes and explanations are followed when installing and commissioning these components.

It is the duty of the technical personnel to use the documentation published at the respective time of each installation and commissioning.

The responsible staff must ensure that the application or use of the products described satisfy all the requirements for safety, including all the relevant laws, regulations, guidelines and standards.

### Disclaimer

The documentation has been prepared with care. The products described are, however, constantly under development.

We reserve the right to revise and change the documentation at any time and without prior announcement.

No claims for the modification of products that have already been supplied may be made on the basis of the data, diagrams and descriptions in this documentation.

### Trademarks

Beckhoff®, TwinCAT®, TwinCAT/BSD®, TC/BSD®, EtherCAT®, EtherCAT G®, EtherCAT G10®, EtherCAT P®, Safety over EtherCAT®, TwinSAFE®, XFC®, XTS® and XPlanar® are registered trademarks of and licensed by Beckhoff Automation GmbH. Other designations used in this publication may be trademarks whose use by third parties for their own purposes could violate the rights of the owners.

### Patent Pending

The EtherCAT Technology is covered, including but not limited to the following patent applications and patents: EP1590927, EP1789857, EP1456722, EP2137893, DE102015105702 with corresponding applications or registrations in various other countries.



EtherCAT® is registered trademark and patented technology, licensed by Beckhoff Automation GmbH, Germany.

### Copyright

© Beckhoff Automation GmbH & Co. KG, Germany.

The reproduction, distribution and utilization of this document as well as the communication of its contents to others without express authorization are prohibited.

Offenders will be held liable for the payment of damages. All rights reserved in the event of the grant of a patent, utility model or design.

## 1.2 Safety instructions

### Safety regulations

Please note the following safety instructions and explanations!  
Product-specific safety instructions can be found on following pages or in the areas mounting, wiring, commissioning etc.

### Exclusion of liability

All the components are supplied in particular hardware and software configurations appropriate for the application. Modifications to hardware or software configurations other than those described in the documentation are not permitted, and nullify the liability of Beckhoff Automation GmbH & Co. KG.

### Personnel qualification

This description is only intended for trained specialists in control, automation and drive engineering who are familiar with the applicable national standards.

### Description of instructions

In this documentation the following instructions are used.  
These instructions must be read carefully and followed without fail!

#### DANGER

##### **Serious risk of injury!**

Failure to follow this safety instruction directly endangers the life and health of persons.

#### WARNING

##### **Risk of injury!**

Failure to follow this safety instruction endangers the life and health of persons.

#### CAUTION

##### **Personal injuries!**

Failure to follow this safety instruction can lead to injuries to persons.

#### NOTE

##### **Damage to environment/equipment or data loss**

Failure to follow this instruction can lead to environmental damage, equipment damage or data loss.



##### **Tip or pointer**

This symbol indicates information that contributes to better understanding.

## 1.3 Documentation issue status

Version	Comment
1.4	<ul style="list-style-type: none"> <li>• Product images updated</li> <li>• Structure update</li> </ul>
1.3	<ul style="list-style-type: none"> <li>• Structure update</li> <li>• Translation updated</li> </ul>
1.2	<ul style="list-style-type: none"> <li>• Dimensions updated</li> <li>• UL requirements updated</li> </ul>
1.1	<ul style="list-style-type: none"> <li>• Front page updated</li> </ul>
1.0	<ul style="list-style-type: none"> <li>• First release</li> </ul>

### Firmware and hardware versions

This documentation refers to the firmware and hardware version that was applicable at the time the documentation was written.

The module features are continuously improved and developed further. Modules having earlier production statuses cannot have the same properties as modules with the latest status. However, existing properties are retained and are not changed, so that older modules can always be replaced with new ones.

The firmware and hardware version (delivery state) can be found in the batch number (D-number) printed on the side of the EtherCAT Box.

### Syntax of the batch number (D-number)

D: WW YY FF HH

WW - week of production (calendar week)

YY - year of production

FF - firmware version

HH - hardware version

Example with D no. 29 10 02 01:

29 - week of production 29

10 - year of production 2010

02 - firmware version 02

01 - hardware version 01

Further information on this topic: [Version identification of EtherCAT devices \[► 48\]](#).

## 2 Product group: EtherCAT P Box modules

### EtherCAT P

EtherCAT P supplements the EtherCAT technology with a process in which communication and supply voltages are transmitted on a common line. All EtherCAT properties are retained with this process.

Two supply voltages are transmitted per EtherCAT P line. The supply voltages are electrically isolated from each other and can therefore be switched individually. The nominal supply voltage for both is 24 V<sub>DC</sub>.

EtherCAT P uses the same cable structure as EtherCAT: a 4-core Ethernet cable with M8 connectors. The connectors are mechanically coded so that EtherCAT connectors and EtherCAT P connectors cannot be interchanged.

### EtherCAT P Box modules

EtherCAT P Box modules are EtherCAT P slaves with degree of protection IP67. They are designed for operation in wet, dirty or dusty industrial environments.

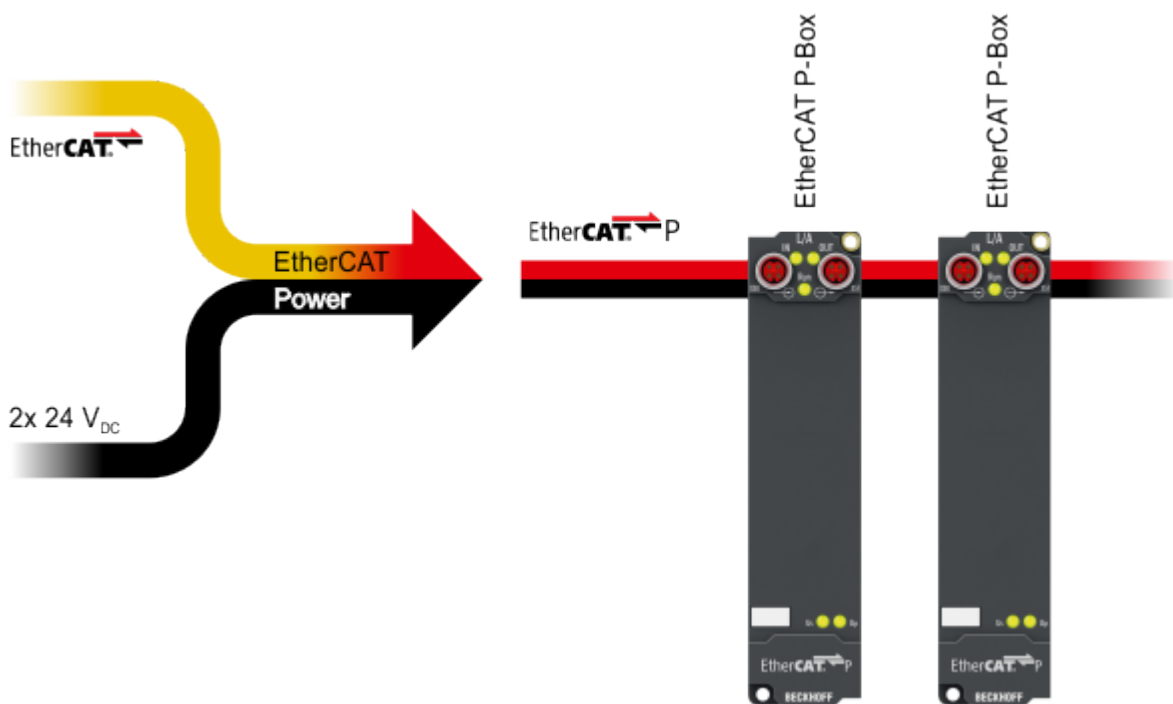

### EtherCAT basics

A detailed description of the EtherCAT system can be found in the [EtherCAT system documentation](#).



### 3 Product overview

#### 3.1 Introduction

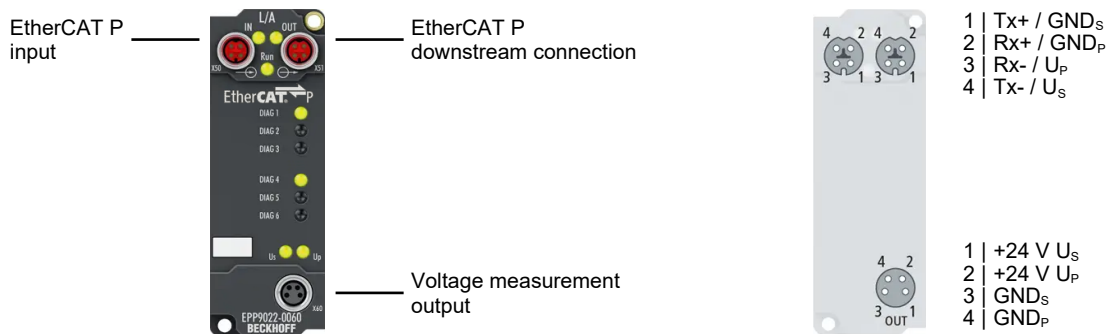

#### EtherCAT P Box with diagnostics

The EPP9022-0060 EtherCAT P Box can be used for diagnosing and measuring the voltages  $U_S$  and  $U_P$  and currents  $I_S$  and  $I_P$ , both temporarily during commissioning and permanently during operation. Even without an EtherCAT master, the voltage range is displayed on the box by LEDs (green, yellow and red). In a running EtherCAT network, the values of  $U_S$ ,  $U_P$ ,  $I_S$  and  $I_P$  can also be read out as process data in the master. The voltage levels for the LED displays can be adjusted by CoE.

In addition the EtherCAT P Box is equipped with an M8 power socket to which an external multimeter can be connected for measuring the voltages.

The EtherCAT P Box modules are characterised by their small and space-saving form factor.

#### Quick links

[Technical data \[▶ 10\]](#)

[Process image \[▶ 13\]](#)

[Dimensions \[▶ 18\]](#)

[Commissioning and configuration \[▶ 28\]](#)

## 3.2 Technical data

All values are typical values over the entire temperature range, unless stated otherwise.

EtherCAT P	
Connection	2 x M8 socket, 4-pin, P-coded, red

Supply voltages	
Connection	See EtherCAT P connection
$U_S$ nominal voltage	24 V <sub>DC</sub> (-15 % / +20 %)
$U_S$ sum current: $I_{S,sum}$	max. 3 A
Current consumption from $U_S$	100 mA
Rated voltage $U_P$	24 V <sub>DC</sub> (-15 % / +20 %)
$U_P$ sum current: $I_{P,sum}$	max. 3 A
Current consumption from $U_P$	None. $U_P$ is only forwarded.

Measured voltage values	
Measuring range	0 ... 32 V <sup>1)</sup>
Resolution	10 mV
Representation	Adjustable [► 29] <ul style="list-style-type: none"> <li>• 1 mV per LSB (factory setting)</li> <li>• 1 <math>\mu</math>V per LSB</li> </ul>

Measured current values	
Measuring range	0 ... 8 A <sup>1)</sup>
Resolution	10 mA
Representation	Adjustable [► 29] <ul style="list-style-type: none"> <li>• 1 mA per LSB (factory setting)</li> <li>• 1 <math>\mu</math>A per LSB</li> </ul>

<sup>1)</sup> The measuring ranges are larger than the permissible voltage and current ranges for continuous operation. However, continuous operation is permitted only within the limits of nominal voltage and sum current.

Voltage measurement output	
Input resistance of the measuring device	Min. 1 M $\Omega$
Short-circuit proof	Yes

Housing data	
Dimensions W x H x D	30 mm x 86 mm x 22 mm (without plug connectors)
Weight	approx. 95 g
Installation position	variable
Material	PA6 (polyamide)

<b>Environmental conditions</b>	
Ambient temperature during operation	-25 ... +60 °C -25 ... +55 °C according to cULus
Ambient temperature during storage	-40 ... +85 °C
Vibration resistance, shock resistance	conforms to EN 60068-2-6 / EN 60068-2-27 Additional tests
EMC immunity / emission	conforms to EN 61000-6-2 / EN 61000-6-4
Protection class	IP65, IP66, IP67 (conforms to EN 60529)
<b>Approvals / markings</b>	
Approvals / markings *)	CE, <u>cULus</u> [► 26]

\*) Real applicable approvals/markings see type plate on the side (product marking).

### 3.3 Scope of supply

Make sure that the following components are included in the scope of delivery:

- 1x EPP9022-0060 EtherCAT P Box
- 1x protective cap for EtherCAT P socket, M8, red (pre-assembled)
- 1x protective cap for supply voltage output, M8, black (pre-assembled)
- 10x labels, blank (1 strip of 10)

---

**i** **Pre-assembled protective caps do not ensure IP67 protection**

Protective caps are pre-assembled at the factory to protect connectors during transport. They may not be tight enough to ensure IP67 protection.

Ensure that the protective caps are correctly seated to ensure IP67 protection.

---

## 3.4 Process image

- └─ Box 1 (EPP9022-0060)
  - ▷ EPM Inputs Channel 1
  - ▷ EPM Inputs Channel 2
  - ▷ WcState
  - ▷ InfoData

The process image contains two process data objects:

Process data object	Contents
<a href="#">EPM Inputs Channel 1 [▶ 14]</a>	Measured values and status information for the control voltage $U_s$
<a href="#">EPM Inputs Channel 2 [▶ 16]</a>	Measured values and status information for the peripheral voltage $U_p$

The content of the process data objects is described on the following pages.















## EPM Inputs Channel 1

- └─ EPM Inputs Channel 1
  - └─ Status
    - ✚ Voltage min error
    - ✚ Voltage max error
    - ✚ Current max error
    - ✚ Voltage min warning
    - ✚ Voltage max warning
    - ✚ Current max warning
    - ✚ Channel error
    - ✚ Channel warning
    - ✚ TxPDO State
    - ✚ TxPDO Toggle
  - ✚ Voltage
  - ✚ Current

**Status**

The status bits indicate warnings and errors [[▶ 31](#)]:

- ✚ Voltage min error  
Error message in case of undervoltage.  
This bit is TRUE if the supply voltage  $U_S$  is lower than CoE index 8000:11 "Voltage min error limit" (unit: mV).  
Requirement: CoE parameter 8000:02 "Enable voltage min error" is TRUE.
- ✚ Voltage max error  
Error message in case of overvoltage.  
This bit is TRUE if the supply voltage  $U_S$  is higher than CoE parameter 8000:12 "Voltage max error limit" (unit: mV).  
Requirement: CoE parameter 8000:03 "Enable voltage max error" is TRUE.
- ✚ Current max error  
Error message in case of overcurrent.  
This bit is TRUE if the output current  $I_S$  is higher than CoE parameter 8000:13 "Current max error limit" (unit: mA).  
Requirement: CoE parameter 8000:04 "Enable current max Error" is TRUE (default).
- ✚ Voltage min warning  
Warning message in case of undervoltage.  
This bit is TRUE if the supply voltage  $U_S$  is lower than CoE parameter 8000:14 "Voltage min warning limit" (unit: mV).  
Requirement: CoE parameter 8000:05 "Enable voltage min warning" is TRUE (default).
- ✚ Voltage max warning  
Warning message in case of overvoltage.  
This bit is TRUE if the supply voltage  $U_S$  is higher than CoE parameter 8000:15 "Voltage max warning limit" (unit: mV).  
Requirement: CoE parameter 8000:06 "Enable voltage max warning" is TRUE (default).
- ✚ Current max warning  
Warning message in case of overcurrent.  
This bit is TRUE if the output current  $I_S$  is higher than CoE parameter 8000:16 "Current max warning limit" (unit: mV).  
Requirement: CoE parameter 8000:07 "Enable current max warning" is TRUE (default).
- ✚ Channel error  
This bit is TRUE if at least one status bit of "EPM Inputs Channel 1" that signals an error message is TRUE:
  - Voltage min error
  - Voltage max error
  - Current max error
- ✚ Channel warning  
This bit is TRUE if at least one Status bit of "EPM Inputs Channel 1" that signals a warning message is TRUE:
  - Voltage min warning
  - Voltage max warning
  - Current max warning
- ✚ TxPDO State  
This bit is TRUE if an internal error occurs. The current measured values [[▶ 15](#)] of "EPM Inputs Channel 1" are invalid if this bit is TRUE.
- ✚ TxPDO Toggle  
This bit is inverted on each update of the measured values [[▶ 15](#)].

- ▲  EPM Inputs Channel 1
  - ▲  Status
    -  Voltage min error
    -  Voltage max error
    -  Current max error
    -  Voltage min warning
    -  Voltage max warning
    -  Current max warning
    -  Channel error
    -  Channel warning
    -  TxPDO State
    -  TxPDO Toggle
  -  Voltage
  -  Current

**Voltage**

Contents: The measured value of the supply voltage  $U_s$ .

Data type: DINT

Presentation:

Default: 1 mV per LSB (factory setting)

Adjustable in the CoE parameter 8000:17 "Voltage scaling".

**Current**

Contents: The measured value of the output current  $I_s$ .

Data type: DINT

Presentation:

1 mA per LSB (factory setting)

Adjustable in the CoE parameter 8000:18 "Current scaling".

## EPM Inputs Channel 2

- ▲ EPM Inputs Channel 2
  - ▲ Status
    - ▶ Voltage min error
    - ▶ Voltage max error
    - ▶ Current max error
    - ▶ Voltage min warning
    - ▶ Voltage max warning
    - ▶ Current max warning
    - ▶ Channel error
    - ▶ Channel warning
    - ▶ TxPDO State
    - ▶ TxPDO Toggle
    - ▶ Voltage
    - ▶ Current

## Status

The status bits indicate warnings and errors [[▶ 31](#)]:

- ▶ Voltage min error  
Error message in case of undervoltage.  
This bit is TRUE if the supply voltage  $U_p$  is lower than CoE index 8010:11 "Voltage min error limit" (unit: mV).  
Requirement: CoE index 8010:02 "Enable voltage min error" is TRUE.
- ▶ Voltage max error  
Error message in case of overvoltage.  
This bit is TRUE if the supply voltage  $U_p$  is higher than CoE index 8010:12 "Voltage max error limit" (unit: mV).  
Requirement: CoE index 8010:03 "Enable voltage max error" is TRUE.
- ▶ Current max error  
Error message in case of overcurrent.  
This bit is TRUE if the output current  $I_p$  is higher than CoE index 8010:13 "Current max error limit" (unit: mA).  
Requirement: CoE index 8010:04 "Enable current max Error" is TRUE (default).
- ▶ Voltage min warning  
Warning message in case of undervoltage.  
This bit is TRUE if the supply voltage  $U_p$  is lower than CoE index 8010:14 "Voltage min warning limit" (unit: mV).  
Requirement: CoE index 8010:05 "Enable voltage min warning" is TRUE (default).
- ▶ Voltage max warning  
Warning message in case of overvoltage.  
This bit is TRUE if the supply voltage  $U_p$  is higher than CoE index 8010:15 "Voltage max warning limit" (unit: mV).  
Requirement: CoE index 8010:06 "Enable voltage max warning" is TRUE (default).
- ▶ Current max warning  
Warning message in case of overcurrent.  
This bit is TRUE if the output current  $I_p$  is higher than CoE index 8010:16 "Current max warning limit" (unit: mV).  
Requirement: CoE index 8010:07 "Enable current max warning" is TRUE (default).
- ▶ Channel error  
This bit is TRUE if at least one status bit of "EPM Inputs Channel 2" that signals an error message is TRUE:
  - Voltage min error
  - Voltage max error
  - Current max error
- ▶ Channel warning  
This bit is TRUE if at least one Status bit of "EPM Inputs Channel 2" that signals a warning message is TRUE:
  - Voltage min warning
  - Voltage max warning
  - Current max warning
- ▶ TxPDO State  
This bit is TRUE if an internal error occurs. The current measured values [[▶ 17](#)] of "EPM Inputs Channel 2" are invalid if this bit is TRUE.
- ▶ TxPDO Toggle  
This bit is inverted on each update of the measured values [[▶ 17](#)].



- ▲ EPM Inputs Channel 2
  - ▲ Status
    - ⚙ Voltage min error
    - ⚙ Voltage max error
    - ⚙ Current max error
    - ⚙ Voltage min warning
    - ⚙ Voltage max warning
    - ⚙ Current max warning
    - ⚙ Channel error
    - ⚙ Channel warning
    - ⚙ TxPDO State
    - ⚙ TxPDO Toggle
  - ⚙ Voltage
  - ⚙ Current

**Voltage**

Contents: The measured value of the supply voltage  $U_p$ .

Data type: DINT

Presentation:

Default: 1 mV per LSB (factory setting)

Adjustable in the CoE index 8010:17 "Voltage scaling".

**Current**

Contents: The measured value of the output current  $I_p$ .

Data type: DINT

Presentation:

1 mA per LSB (factory setting)

Adjustable in the CoE index 8010:18 "Current scaling".

## 4 Mounting and connections

### 4.1 Mounting

#### 4.1.1 Dimensions

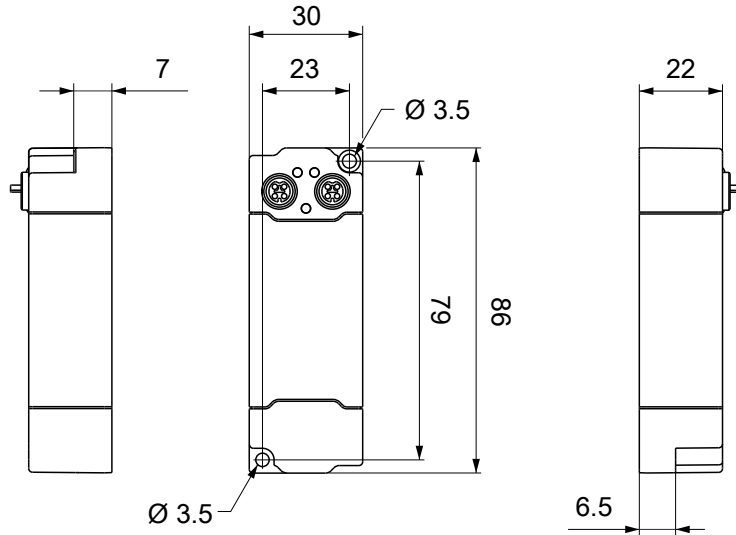

All dimensions are given in millimeters.  
The drawing is not true to scale.

#### Housing features

Housing material	PA6 (polyamide)
Sealing compound	polyurethane
Mounting	two mounting holes $\varnothing$ 3.5 mm for M3
Metal parts	brass, nickel-plated
Contacts	CuZn, gold-plated
Installation position	variable
Protection class	IP65, IP66, IP67 (conforms to EN 60529) when screwed together
Dimensions (H x W x D)	approx. 86 x 30 x 22 mm
Weight	approx. 90 g

## 4.1.2 Fixing

### NOTE

#### Dirt during assembly

Dirty connectors can lead to malfunctions. Protection class IP67 can only be guaranteed if all cables and connectors are connected.

- Protect the plug connectors against dirt during the assembly.

Mount the module with two M3 screws on the mounting holes in the corners of the module. The mounting holes have no thread.

## 4.1.3 Functional earth (FE)

The upper mounting holes also serves as a connection for functional earth (FE).

Make sure that the box is grounded to low impedance via the functional earth (FE) connection. You can achieve this, for example, by mounting the box on a grounded machine bed.



Fig. 1: Connection for functional earth (FE)

## 4.2 Connections

### 4.2.1 Overview



Name	Function	Connector type	Tightening torque
X50	<a href="#">EtherCAT P input [► 21]</a>	M8 socket, p-coded	0.4 Nm <sup>1)</sup>
X51	<a href="#">EtherCAT P downstream connection [► 21]</a>	M8 socket, p-coded	0.4 Nm <sup>1)</sup>
X60	<a href="#">Voltage measurement output [► 25]</a>	M8 socket	0.4 Nm <sup>1)</sup>

<sup>1)</sup> Mount plugs on these connectors using a torque wrench, e.g. ZB8801 from Beckhoff.

#### Protective caps

- Seal unused connectors with protective caps.
- Ensure the correct seating of pre-assembled protective caps.  
Protective caps are pre-assembled at the factory to protect connectors during transport. They may not be tight enough to ensure IP67 protection.

## 4.2.2 EtherCAT P

### ⚠ WARNING

#### Power supply from SELV/PELV power supply unit!

SELV/PELV circuits (Safety Extra Low Voltage, Protective Extra Low Voltage) according to IEC 61010-2-201 must be used to supply the EtherCAT P Power Sourcing Device (PSD).

Notes:

- SELV/PELV circuits may give rise to further requirements from standards such as IEC 60204-1 et al, for example with regard to cable spacing and insulation.
- A SELV (Safety Extra Low Voltage) supply provides safe electrical isolation and limitation of the voltage without a connection to the protective conductor, a PELV (Protective Extra Low Voltage) supply also requires a safe connection to the protective conductor.

### ⚠ CAUTION

#### Observe the UL requirements

- When operating under UL conditions, observe the warnings in the chapter [UL Requirements \[► 26\]](#).

EtherCAT P transmits two supply voltages:

- **Control voltage  $U_s$**   
The following sub-functions are supplied from the control voltage  $U_s$ :
  - the fieldbus
  - the processor logic
  - typically the inputs and the sensors if the EtherCAT P Box has inputs.
- **Peripheral voltage  $U_p$**   
The digital outputs are typically supplied from the peripheral voltage  $U_p$  for EtherCAT P Box modules with digital outputs.  $U_p$  can be supplied separately. If  $U_p$  is switched off, the fieldbus function, the function of the inputs and the supply of the sensors are maintained.

The exact assignment of  $U_s$  and  $U_p$  can be found in the pin assignment of the I/O connections.

#### Redirection of the supply voltages

The supply voltages are passed on internally from the "IN" connection to the "OUT" connection. Hence, the supply voltages  $U_s$  and  $U_p$  can be passed from one EtherCAT P Box to the next EtherCAT P Box in a simple manner.

### NOTE

#### Note the maximum current.

Ensure that the maximum permitted current of 3 A for the M8 connectors is not exceeded when redirecting EtherCAT P.

### 4.2.2.1 Connectors

**NOTE**

**Risk of damage to the device!**

Bring the EtherCAT/EtherCAT P system into a safe, powered down state before starting installation, disassembly or wiring of the modules!

Two M8 sockets at the upper end of the modules are provided for supply and downstream connection of EtherCAT P:

- IN: left M8 socket for EtherCAT P supply
- OUT: right M8 socket for downstream connection of EtherCAT P

The metal threads of the M8 EtherCAT P sockets are internally linked to the FE connection via high impedance RC combination. See chapter [Functional earth \(FE\)](#) [► 19].



1 - input

2 - downstream connection

**Connection**

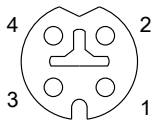

Fig. 2: M8 socket, P-coded

Contact	Signal	Voltage	Core color <sup>1)</sup>
1	Tx +	GND <sub>S</sub>	yellow
2	Rx +	GND <sub>P</sub>	white
3	Rx -	U <sub>P</sub> : peripheral voltage, +24 V <sub>DC</sub>	blue
4	Tx -	U <sub>S</sub> : control voltage, +24 V <sub>DC</sub>	orange
Housing	Shield	Shield	Shield

<sup>1)</sup> The core colors apply to EtherCAT P cables and ECP cables from Beckhoff.

### 4.2.2.2 Status LEDs

#### 4.2.2.2.1 Supply voltages



Fig. 3: Status LEDs for the supply voltages

LED	Display	Meaning
U <sub>C</sub> (control voltage)	Off	The supply voltage U <sub>C</sub> is not available.
	Green light	The supply voltage U <sub>C</sub> is available.
	Red light	Overload of the sensor power supply generated from U <sub>C</sub> . The sensor supply was then switched off for all connected sensors.
U <sub>P</sub> (peripheral voltage)	Off	The supply voltage U <sub>P</sub> is not available.
	Green light	The supply voltage U <sub>P</sub> is available.

#### 4.2.2.2.2 EtherCAT



Fig. 4: Status LEDs for EtherCAT

##### L/A (Link/Act)

A green LED labeled "L/A" or "Link/Act" is located next to each EtherCAT/EtherCAT P socket. The LED indicates the communication state of the respective socket:

LED	Meaning
off	no connection to the connected EtherCAT device
lit	LINK: connection to the connected EtherCAT device
flashes	ACT: communication with the connected EtherCAT device

##### Run

Each EtherCAT slave has a green LED labelled "Run". The LED signals the status of the slave in the EtherCAT network:

LED	Meaning
off	Slave is in "Init" state
flashes uniformly	Slave is in "Pre-Operational" state
flashes sporadically	Slave is in "Safe-Operational" state
lit	Slave is in "Operational" state

##### Description of the EtherCAT slave states

### 4.2.2.3 Conductor losses

Take into account the voltage drop on the supply line when planning a system. Avoid the voltage drop being so high that the supply voltage at the box lies below the minimum nominal voltage. Variations in the voltage of the power supply unit must also be taken into account.

#### **i** Planning tool for EtherCAT P

You can plan cable lengths, voltages and currents of your EtherCAT P system using TwinCAT 3. The requirement for this is TwinCAT 3 Build 4020 or higher.

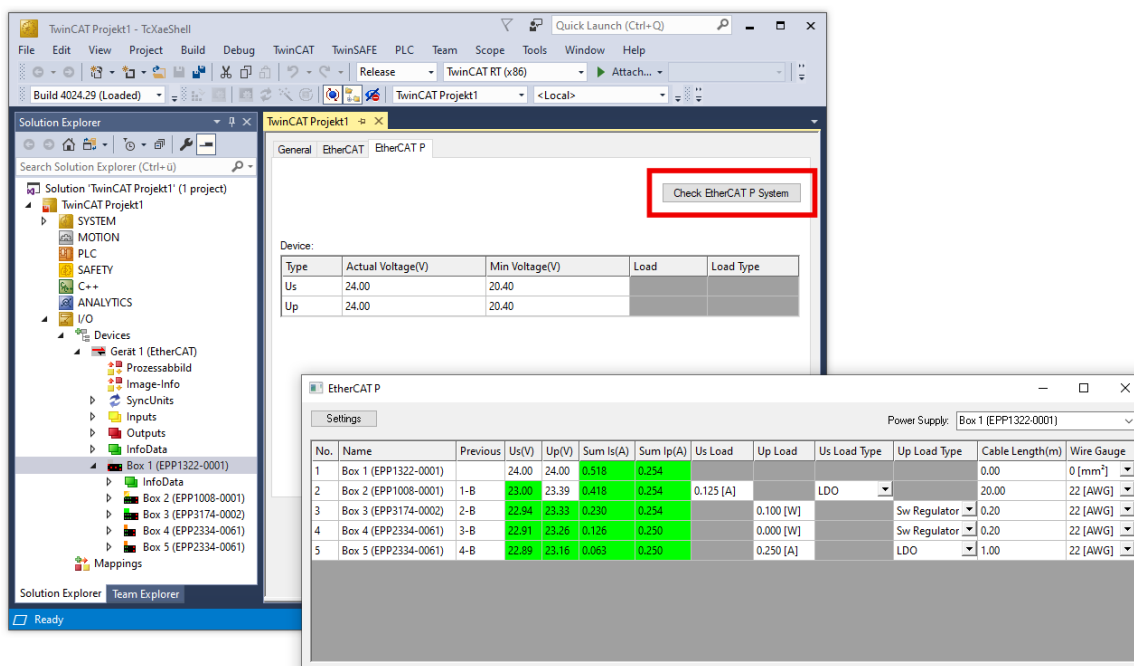

Further information can be found in the quick start guide [IO configuration in TwinCAT](#) in chapter "Configuration of EtherCAT P via TwinCAT".

#### Voltage drop on the supply line

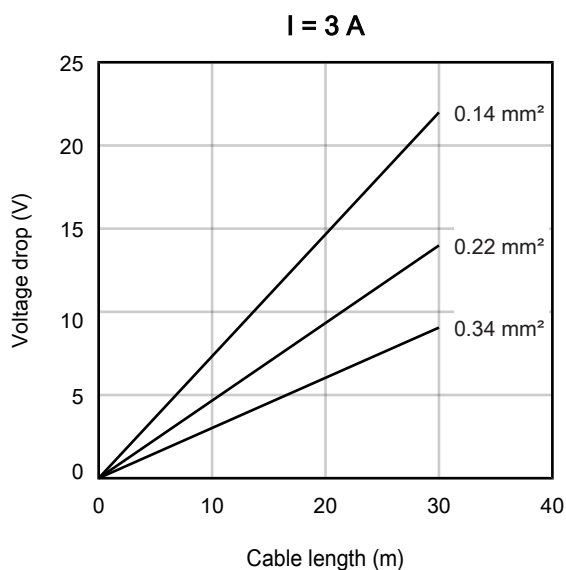



### 4.2.3 Voltage measurement output

You can check the supply voltages manually at the voltage measurement output, for example using a multimeter.

- i** **An unsuitable measuring device can falsify the measurement.**  
 The measurement will be falsified if the input resistance of the connected measuring device is too small.
  - Use a measuring device that meets the requirements in the [technical data \[► 10\]](#).

- i** **The measurement output cannot be used as a supply voltage output**  
 The output voltages will collapse if they are loaded.
  - Do *not* use the measurement output as a supply voltage output.  
 If you wish to decouple the supply voltages from an EtherCAT P signal, use an [EPP9001-0060](#), for example.

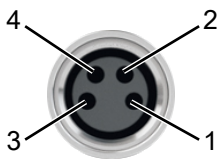

Fig. 5: Voltage measurement output, M8 socket

Contact	Potential	Description	Core color <sup>1)</sup>
1	$U_{S1}$	Control voltage	Brown
2	$U_{P1}$	Peripheral voltage	White
3	$GND_S$	Reference ground to $U_{S1}$	Blue
4	$GND_P$	Reference ground to $U_{P1}$	Black

<sup>1)</sup> The core colors apply to cables of the type: Beckhoff ZK2020-xxxx-xxxx

## 4.3 UL Requirements

The installation of the EtherCAT Box Modules certified by UL has to meet the following requirements.

### Supply voltage

#### ⚠ CAUTION

##### CAUTION!

This UL requirements are valid for all supply voltages of all marked EtherCAT Box Modules!  
For the compliance of the UL requirements the EtherCAT Box Modules should only be supplied

- by a 24 V<sub>DC</sub> supply voltage, supplied by an isolating source and protected by means of a fuse (in accordance with UL248), rated maximum 4 Amp, or
- by a 24 V<sub>DC</sub> power source, that has to satisfy *NEC class 2*.  
A *NEC class 2* power supply shall not be connected in series or parallel with another (class 2) power source!

#### ⚠ CAUTION

##### CAUTION!

To meet the UL requirements, the EtherCAT Box Modules must not be connected to unlimited power sources!

### Networks

#### ⚠ CAUTION

##### CAUTION!

To meet the UL requirements, EtherCAT Box Modules must not be connected to telecommunication networks!

### Ambient temperature range

#### ⚠ CAUTION

##### CAUTION!

To meet the UL requirements, EtherCAT Box Modules has to be operated only at an ambient temperature range of -25 °C to +55 °C!

### Marking for UL

All EtherCAT Box Modules certified by UL (Underwriters Laboratories) are marked with the following label.



Fig. 6: UL label

## 4.4 Disposal



Products marked with a crossed-out wheeled bin shall not be discarded with the normal waste stream. The device is considered as waste electrical and electronic equipment. The national regulations for the disposal of waste electrical and electronic equipment must be observed.

## **5 Commissioning and configuration**

### **5.1 Integrating into a TwinCAT project**

The procedure for integration in a TwinCAT project is described in these [Quick start guide](#).

## 5.2 Measured values

### 5.2.1 Representation

- All measured voltage values are represented in mV / LSB in the factory setting. They can optionally also be represented in  $\mu$ V / LSB.
- All measured current values are represented in mA / LSB in the factory setting. They can optionally also be represented in  $\mu$ A / LSB.

The type of representation has no effect on the resolution of the measured values.

You can set the representation of the measured values individually for each measured value:

Input channel		CoE parameters for setting the representation	
		for the measured voltage value	for the measured current value
1	Control voltage $U_s$	8000:17 "Voltage scaling" [ <a href="#">▶ 40</a> ]	8000:18 "Current scaling" [ <a href="#">▶ 40</a> ]
2	Peripheral voltage $U_p$	8010:17 "Voltage scaling" [ <a href="#">▶ 41</a> ]	8010:18 "Current scaling" [ <a href="#">▶ 41</a> ]

## 5.2.2 Filter

The measured value of each input channel can be filtered with a digital filter.

### Enable filter

#### NOTE

#### Measured value jumps when enabling or disabling filters

When filters are enabled or disabled, short-term measured value jumps can occur in the process data that do not correspond to the physical values.

You can enable the filter individually for each input channel. All filters are disabled in the factory setting. Enable the filters by setting the following CoE parameters to TRUE:

Input channel		CoE parameters for enabling the filter
1	Control voltage $U_s$	8000:01 "Enable filter" [ <a href="#">▶ 40</a> ]
2	Peripheral voltage $U_p$	8010:01 "Enable filter" [ <a href="#">▶ 41</a> ]

### Select filter characteristic

You can select the filter characteristic individually for each input. Factory setting: "50 Hz FIR".

Input channel		CoE parameter for selecting the filter characteristic
1	Control voltage $U_s$	8000:19 "Filter characteristic" [ <a href="#">▶ 40</a> ]
2	Peripheral voltage $U_p$	8010:19 "Filter characteristic" [ <a href="#">▶ 41</a> ]

There is a choice of two filter types:

#### FIR filter

The filter works as a notch filter and determines the conversion time of the module. The higher the filter frequency, the faster the conversion time. A 50 Hz and a 60 Hz filter are available.

Notch filter means that the filter has zeros (notches) in the frequency response at the filter frequency and multiples thereof, i.e. it attenuates the amplitude at these frequencies.

The FIR filter operates as a non-recursive filter.

#### IIR filter

The filter with IIR characteristics is a discrete time, linear, time invariant filter that can be set to eight levels (level 1 = weak recursive filter, up to level 8 = strong recursive filter)

The IIR can be understood to be a moving average value calculation after a low-pass filter.

### 5.3 Warning and error messages

Warning messages and error messages inform you of potentially critical operating states. EPP9022 signals warning messages and error messages in two ways:

- [Process image](#) [▶ 14]
- [LEDs](#) [▶ 34]

There are two categories of messages:

- A *warning message* is output if a measured value (current, voltage) is borderline. However, continuous operation is still possible under unchanged conditions.
- An *error message* is output if continuous operation under unchanged conditions could lead to a defect or to the tripping of a safety device.

The following diagrams show the threshold values for warning messages and error messages in the factory setting.

#### Threshold values for supply voltages (factory setting)

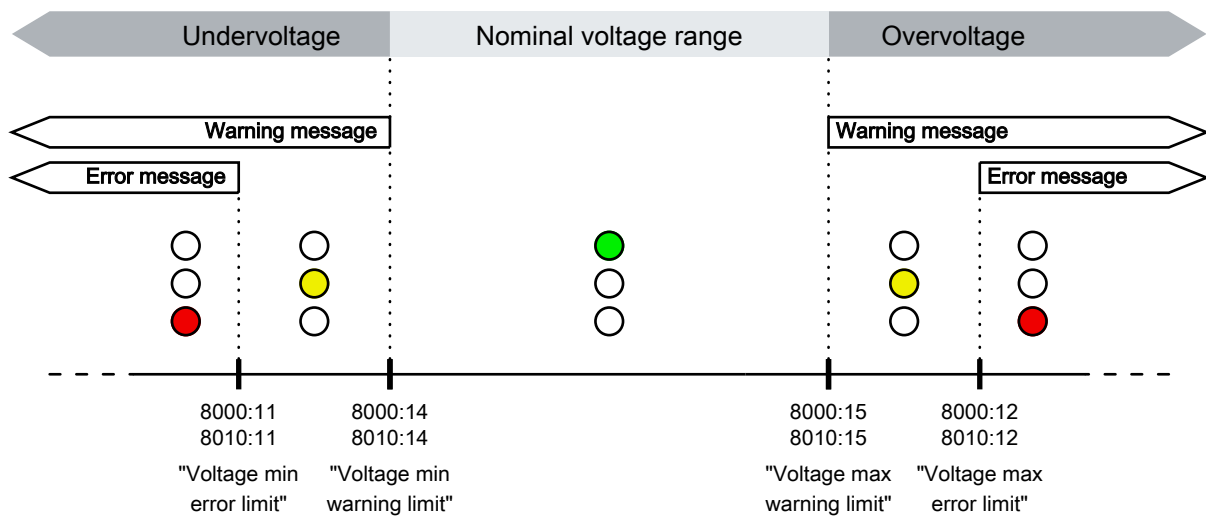

#### Threshold values for output currents (factory setting)

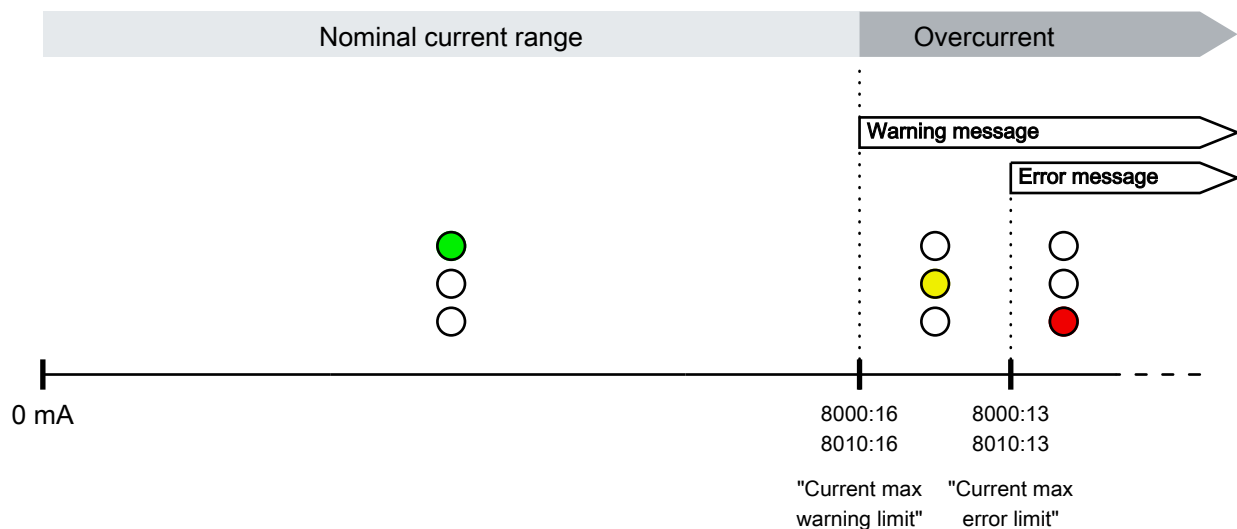

### 5.3.1 Set the threshold values

#### NOTE

#### Critical operating states may not be reported under certain circumstances.

If you set the threshold values for warning messages and error messages incorrectly, EPP9022 may not inform you of critical operating states:  
overcurrent, overvoltage, undervoltage.

- Be very careful when changing the threshold values.
- Enlarge the permissible range only if you have good reasons to do so.

You can set the threshold values for warning messages and error messages via the CoE parameters shown in the following tables. Observe the recommended value range.

#### Input channel 1: Control voltage $U_s$

Reason for message	Type of message	CoE parameters for setting the threshold value	Unit	Recommended value range	Factory setting
Undervoltage	Warning message	8000:14 "Voltage min warning limit"	mV	min. 20400 <sub>dec</sub>	20400 <sub>dec</sub>
	Error message	8000:11 "Voltage min error limit"	mV	min. 18000 <sub>dec</sub>	18000 <sub>dec</sub>
Overvoltage	Warning message	8000:15 "Voltage max warning limit"	mV	max. 28800 <sub>dec</sub>	28800 <sub>dec</sub>
	Error message	8000:12 "Voltage max error limit"	mV	max. 30000 <sub>dec</sub>	30000 <sub>dec</sub>
Overcurrent	Warning	8000:16 "Current max warning limit"	mA	0 .. 2500 <sub>dec</sub>	2500 <sub>dec</sub>
	Error message	8000:13 "Current max error limit"	mA	0 .. 3000 <sub>dec</sub>	3000 <sub>dec</sub>

#### Input channel 2: Peripheral voltage $U_p$

Reason for message	Type of message	CoE parameters for setting the threshold value	Unit	Recommended value range	Factory setting
Undervoltage	Warning message	8010:14 "Voltage min warning limit"	mV	min. 20400 <sub>dec</sub>	20400 <sub>dec</sub>
	Error message	8010:11 "Voltage min error limit"	mV	min. 18000 <sub>dec</sub>	18000 <sub>dec</sub>
Overvoltage	Warning message	8010:15 "Voltage max warning limit"	mV	max. 28800 <sub>dec</sub>	28800 <sub>dec</sub>
	Error message	8010:12 "Voltage max error limit"	mV	max. 30000 <sub>dec</sub>	30000 <sub>dec</sub>
Overcurrent	Warning	8010:16 "Current max warning limit"	mA	0 .. 2500 <sub>dec</sub>	2500 <sub>dec</sub>
	Error message	8010:13 "Current max error limit"	mA	0 .. 3000 <sub>dec</sub>	3000 <sub>dec</sub>



### 5.3.2 Disabling messages

**NOTE**

**Critical operating states may not be reported under certain circumstances.**

If you disable warning messages or error messages, EPP9022 will no longer inform you of critical operating states:

overcurrent, overvoltage, undervoltage.

- Disable warning messages or error messages only if you have good reasons to do so.

You can disable the corresponding warning message/error message for each threshold value. All warning messages and error messages are enabled in the factory setting.

To disable a warning message or error message, search for the CoE parameter for the desired message in the tables below and set it to FALSE:

**Input channel 1: Control voltage  $U_c$**

Reason for message	Type of message	CoE parameter for enabling/ disabling the message
Undervoltage	Warning message	8000:05 "Enable voltage min warning"
	Error message	8000:02 "Enable voltage min error"
Overvoltage	Warning message	8000:06 "Enable voltage max warning"
	Error message	8000:03 "Enable voltage max error"
Overcurrent	Warning message	8000:07 "Enable current max warning"
	Error message	8000:04 "Enable current max error"

**Input channel 2: Peripheral voltage  $U_p$**

Reason for message	Type of message	CoE parameter for enabling/ disabling the message
Undervoltage	Warning message	8010:05 "Enable voltage min warning"
	Error message	8010:02 "Enable voltage min error"
Overvoltage	Warning message	8010:06 "Enable voltage max warning"
	Error message	8010:03 "Enable voltage max error"
Overcurrent	Warning message	8010:07 "Enable current max warning"
	Error message	8010:04 "Enable current max error"

## 5.4 LEDs

LEDs signal warning messages and error messages [► 31]. There are three LEDs for each input channel ( $U_S$  /  $U_P$ ):

- Green = no message
- Yellow = warning message. At least one warning threshold value has been exceeded.
- Red = error message. At least one error threshold value has been exceeded.

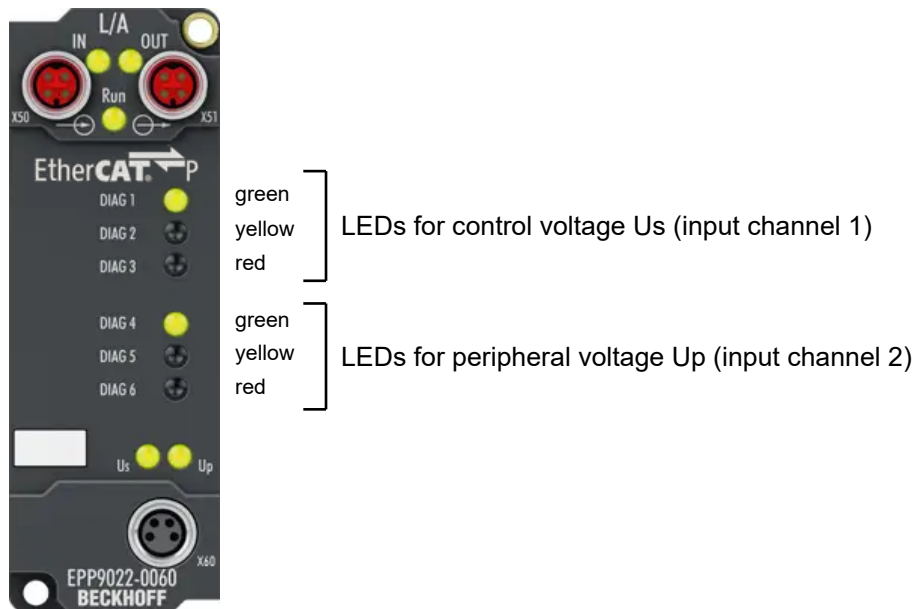

Fig. 7: Assignment of the LEDs

Precisely one LED lights up per input channel at any one time. If warning messages and error messages are present simultaneously, only the red LED lights up.

Check the Status bits [► 14] in order to further localize the cause of the warning message or error message.

You can also use the LEDs for offline diagnostics: The LEDs are also active if no EtherCAT Master is present.

You can influence the behavior of the LEDs:

- Change threshold values [► 32].
- Disable [► 33] individual warning messages and error messages.
- Limit LED display to currents or voltages: LED filter [► 35].

### 5.4.1 LED filter

#### NOTE

##### Critical operating states may not be displayed under certain circumstances.

If you filter out messages with the LED filter, critical operating states may no longer be displayed by the LEDs under certain circumstances.

- Only use the LED filter if you have good reasons to do so.

Use the LED filter if you do not wish certain messages to be displayed by the LEDs. The LED filter can filter out two types of message:

- Messages that concern currents.
- Messages that concern voltages.

The LED filter can be set individually for each input channel:

Input channel		CoE parameters for setting the LED filter
1	Control voltage $U_s$	8000:1A "LED filter" [▶ 40]
2	Peripheral voltage $U_p$	8010:1A "LED filter" [▶ 40]

The following options are available:

Value	Enum	Description
0	"Voltage and current"	The LEDs signal all messages.
1	"Voltage only"	The LEDs signal only messages that concern currents.
2	"Current only"	The LEDs signal only messages that concern voltages.
255 <sub>dec</sub>	"LEDs off"	All LEDs are off.

## 5.5 Restoring the delivery state

To restore the delivery state for backup objects in ELxxxx terminals / EPxxxx- and EPPxxxx box modules, the CoE object *Restore default parameters, SubIndex 001* can be selected in the TwinCAT System Manager (Config mode).

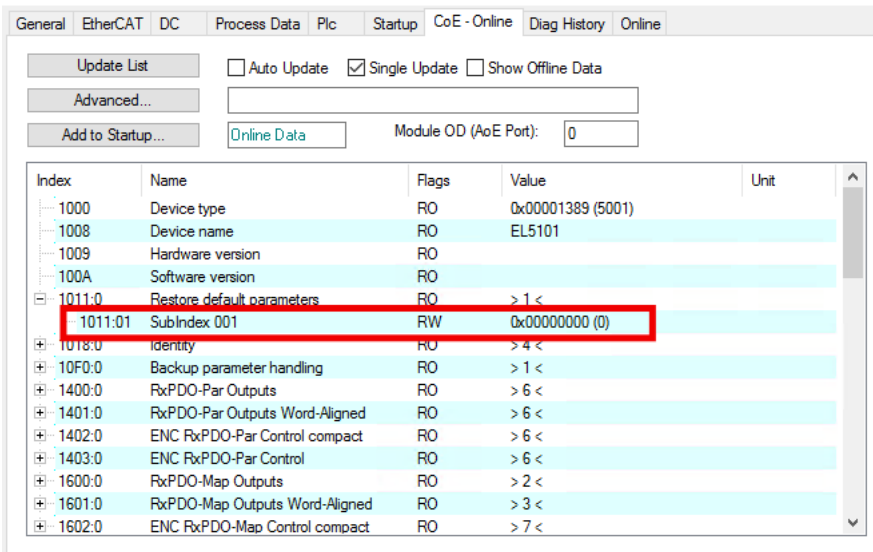

Fig. 8: Selecting the Restore default parameters PDO

Double-click on *SubIndex 001* to enter the Set Value dialog. Enter the value **1684107116** in field *Dec* or the value **0x64616F6C** in field *Hex* and confirm with OK.

All backup objects are reset to the delivery state.

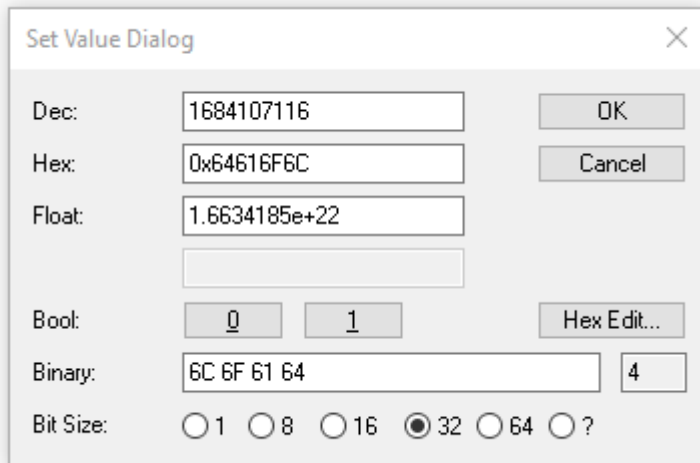

Fig. 9: Entering a restore value in the Set Value dialog

### Alternative restore value

In some older terminals / boxes the backup objects can be switched with an alternative restore value:

Decimal value: 1819238756

Hexadecimal value: 0x6C6F6164

An incorrect entry for the restore value has no effect.

## 5.6 Decommissioning

**⚠ WARNING****Risk of electric shock!**

Bring the bus system into a safe, de-energized state before starting disassembly of the devices!

## 6 CoE parameters

### 6.1 Introduction

#### 6.1.1 Accessing CoE parameters with TwinCAT

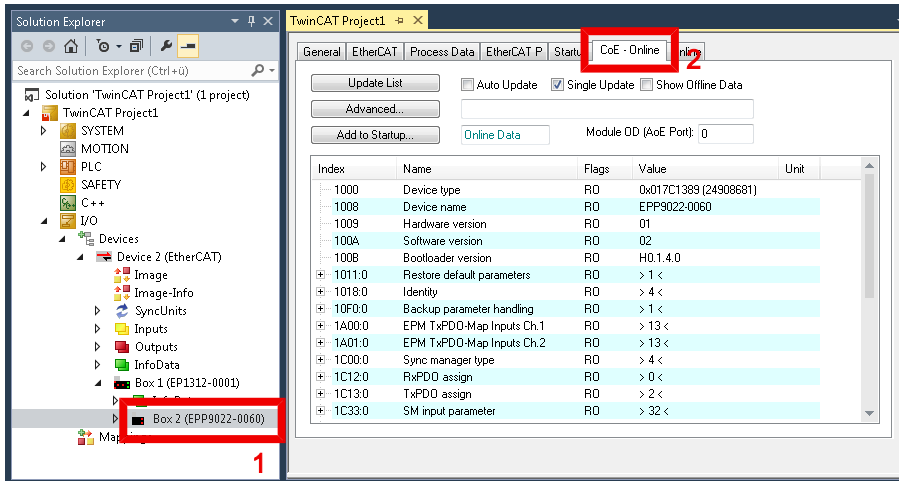

✓ Requirement: EPP9022-0060 exists as an I/O module in the Solution Explorer under the menu item "I/O".

1. Click on the EPP9022-0060 I/O module in the Solution Explorer.

2. Click on the tab "CoE – Online".

⇒ You will see the parameter directory of the EPP9022-0060, where you can check and adjust parameters.

#### 6.1.2 Data format of CoE parameters

CoE parameters have different data formats.

The data format of the CoE parameters is specified by data type identifiers in the chapter [Object description](#) [▶ 40]:

Data type identifier	Format	Size
BOOL	True / false	8-bit
SINT	Short integer	8-bit
USINT	Unsigned short integer	8-bit
INT	Integer	16-bit
UINT	Unsigned integer	16-bit
DINT	Double integer	32-bit
UDINT	Unsigned double integer	32-bit
STRING	String	max. 255 characters, 1 byte per character

The data type identifiers correspond to the [data types](#) that can also be used in TwinCAT in a PLC program.

## 6.2 Object overview

Index (hex)	Name
1000	<a href="#">Device type [► 44]</a>
1008	<a href="#">Device name [► 44]</a>
1009	<a href="#">Hardware version [► 44]</a>
100A	<a href="#">Software version [► 44]</a>
100B	Bootloader version
1011	<a href="#">Restore default parameters [► 44]</a>
1018	<a href="#">Identity [► 44]</a>
10F0	<a href="#">Backup parameter handling [► 44]</a>
1A00	EPM TxPDO-Map Inputs Ch.1
1A01	EPM TxPDO-Map Inputs Ch.2
1C00	Sync manager type
1C12	RxPDO assign
1C13	TxPDO assign
1C33	SM input parameter
6000	<a href="#">EPM Inputs Ch.1 [► 42]</a>
6010	<a href="#">EPM Inputs Ch.2 [► 42]</a>
8000	<a href="#">EPM Settings Ch.1 [► 40]</a>
800F	<a href="#">EPM Vendor data Ch.1 [► 42]</a>
8010	<a href="#">EPM Settings Ch.2 [► 41]</a>
801F	<a href="#">EPM Vendor data Ch.2 [► 42]</a>
A000	<a href="#">EPM Diag data Ch.1 [► 43]</a>
A010	<a href="#">EPM Diag data Ch.2 [► 43]</a>
F000	<a href="#">Modular device profile [► 43]</a>
F008	Code word
F010	<a href="#">Module list [► 43]</a>
FB00	Command

## 6.3 Object description

### 6.3.1 Objects to be parameterized during commissioning

#### Index 8000 EPM Settings Ch.1

Access rights: read/write

Subindex (hex)	Name	Description	Unit	Data type	Default
01	Enable Filter	Enables the <u>measured value filter</u> [► 30]	-	BOOL	FALSE
02	Enable voltage min error	Enables the error message in case of undervoltage	-	BOOL	TRUE
03	Enable voltage max error	Enables the error message in case of overvoltage	-	BOOL	TRUE
04	Enable current max error	Enables the error message in case of overcurrent	-	BOOL	TRUE
05	Enable voltage min warning	Enables the warning message in case of undervoltage	-	BOOL	TRUE
06	Enable voltage max warning	Enables the warning message in case of overvoltage	-	BOOL	TRUE
07	Enable current max warning	Enables the warning message in case of overcurrent	-	BOOL	TRUE
11	Voltage min error limit	Threshold value for the undervoltage error message	mV	UDINT	18000 <sub>dec</sub>
12	Voltage max error limit	Threshold value for the overvoltage error message	mV	UDINT	30000 <sub>dec</sub>
13	Current max error limit	Threshold value for the overcurrent error message	mA	UDINT	3000 <sub>dec</sub>
14	Voltage min warning limit	Threshold value for the undervoltage warning message	mV	UDINT	20400 <sub>dec</sub>
15	Voltage max warning limit	Threshold value for the overvoltage warning message	mV	UDINT	28800 <sub>dec</sub>
16	Current max warning limit	Threshold value for the overcurrent warning message	mA	UDINT	2500 <sub>dec</sub>
17	Voltage scaling	<u>Representation</u> [► 29] of the measured voltage value. 0: 1 mV per LSB (factory setting) 1: 1 $\mu$ V per LSB	-	UINT	0
18	Current scaling	<u>Representation</u> [► 29] of the measured current value. 0: 1 mA per LSB (factory setting) 1: 1 $\mu$ A per LSB	-	UINT	0
19	Filter characteristic	Filter characteristic of the <u>measured value filter</u> [► 30]. 0: 50 Hz FIR (factory setting) 1: 60 Hz FIR 2: IIR1 3: IIR2 4: IIR3 5: IIR4 6: IIR5 7: IIR6 8: IIR7 9: IIR8	-	UINT	0
1A	LED filter	<u>LED filter</u> [► 35] 0: "Voltage and current" (factory setting) 1: "Voltage only" 2: "Current only" 255 <sub>dec</sub> : "LEDs off"	-	UINT	0



**Index 8010 EPM Settings Ch.2**

Access rights: read/write

Subindex (hex)	Name	Description	Unit	Data type	Default
01	Enable Filter	Enables the <a href="#">measured value filter [► 30]</a>	-	BOOL	FALSE
02	Enable voltage min error	Enables the error message in case of undervoltage	-	BOOL	TRUE
03	Enable voltage max error	Enables the error message in case of overvoltage	-	BOOL	TRUE
04	Enable current max error	Enables the error message in case of overcurrent	-	BOOL	TRUE
05	Enable voltage min warning	Enables the warning message in case of undervoltage	-	BOOL	TRUE
06	Enable voltage max warning	Enables the warning message in case of overvoltage	-	BOOL	TRUE
07	Enable current max warning	Enables the warning message in case of overcurrent	-	BOOL	TRUE
11	Voltage min error limit	Threshold value for the undervoltage error message	mV	UDINT	18000 <sub>dec</sub>
12	Voltage max error limit	Threshold value for the overvoltage error message	mV	UDINT	30000 <sub>dec</sub>
13	Current max error limit	Threshold value for the overcurrent error message	mA	UDINT	3000 <sub>dec</sub>
14	Voltage min warning limit	Threshold value for the undervoltage warning message	mV	UDINT	20400 <sub>dec</sub>
15	Voltage max warning limit	Threshold value for the overvoltage warning message	mV	UDINT	28800 <sub>dec</sub>
16	Current max warning limit	Threshold value for the overcurrent warning message	mA	UDINT	2500 <sub>dec</sub>
17	Voltage scaling	<a href="#">Representation [► 29]</a> of the measured voltage value. 0: 1 mV per LSB (factory setting) 1: 1 µV per LSB	-	UINT	0
18	Current scaling	<a href="#">Representation [► 29]</a> of the measured current value. 0: 1 mA per LSB (factory setting) 1: 1 µA per LSB	-	UINT	0
19	Filter characteristic	Filter characteristic of the <a href="#">measured value filter [► 30]</a> . 0: 50 Hz FIR (factory setting) 1: 60 Hz FIR 2: IIR1 3: IIR2 4: IIR3 5: IIR4 6: IIR5 7: IIR6 8: IIR7 9: IIR8	-	UINT	0
1A	LED filter	<a href="#">LED filter [► 35]</a> 0: "Voltage and current" (factory setting) 1: "Voltage only" 2: "Current only" 255 <sub>dec</sub> : "LEDs off"	-	UINT	0

## 6.3.2 Profile-specific objects

### Index 6000 EPM Inputs Ch.1

Access rights: read only

Subindex (hex)	Name	Description	Data type
01	Voltage min error	Input process data. See <a href="#">Process image</a>  ▶  13].	BOOL
02	Voltage max error		BOOL
03	Current max error		BOOL
04	Voltage min warning		BOOL
05	Voltage max warning		BOOL
06	Current max warning		BOOL
07	Channel error		BOOL
11	Channel warning		BOOL
12	TxPDO State		BOOL
13	TxPDO Toggle		BOOL
14	Voltage		DINT
15	Current		DINT

### Index 6010 EPM Inputs Ch.2

Access rights: read only

Subindex (hex)	Name	Description	Data type
01	Voltage min error	Input process data. See <a href="#">Process image</a>  ▶  13].	BOOL
02	Voltage max error		BOOL
03	Current max error		BOOL
04	Voltage min warning		BOOL
05	Voltage max warning		BOOL
06	Current max warning		BOOL
07	Channel error		BOOL
11	Channel warning		BOOL
12	TxPDO State		BOOL
13	TxPDO Toggle		BOOL
14	Voltage		DINT
15	Current		DINT

### Index 800F EPM Vendor data Ch.1

Access rights: read only

Subindex (hex)	Name	Description	Data type
01	Voltage calibration offset	Calibration coefficients of the vendor calibration.	INT
02	Voltage calibration gain		INT
03	Current calibration offset		INT
04	Current calibration gain		INT

### Index 801F EPM Vendor data Ch.2

Access rights: read only

Subindex (hex)	Name	Description	Data type
01	Voltage calibration offset	Calibration coefficients of the vendor calibration.	INT
02	Voltage calibration gain		INT
03	Current calibration offset		INT
04	Current calibration gain		INT

**Index A000 EPM Diag data Ch.1**

Access rights: read only

Subindex (hex)	Name	Description	Unit	Data type
01	Voltage ADC raw value	Raw value of the voltage measurement	-	UINT
02	Current ADC raw value	Raw value of the current measurement	-	UINT

**Index A010 EPM Diag data Ch.2**

Access rights: read only

Subindex (hex)	Name	Description	Unit	Data type
01	Voltage ADC raw value	Raw value of the voltage measurement	-	UINT
02	Current ADC raw value	Raw value of the current measurement	-	UINT

**Index F000 Modular device profile**

Access rights: read only

Subindex (hex)	Name	Description	Data type	Value
01	Module index distance	Offset between the indices of the parameter objects of two channels	UINT	0x0010
02	Maximum number of modules	Number of channels	UINT	2

**Index F010 Module list**

Access rights: read/write

Subindex (hex)	Name	Description	Data type	Default
01	SubIndex 001	Module profile of input channel 1	UDINT	380 <sub>dec</sub>
02	SubIndex 002	Module profile of input channel 1	UDINT	380 <sub>dec</sub>

### 6.3.3 Standard objects

#### Index 1000 Device type

Access rights: read only

Subindex (hex)	Name	Description	Data type	Value
-	Device type	Bit 0 .. 15: Device profile number Bit 16 .. 31: Module profile number  (Device profile number 5001: Modular Device Profile MDP)	UDINT	5001 <sub>dec</sub>

#### Index 1008 Device name

Access rights: read only

Subindex (hex)	Name	Description	Data type	Value
-	Device name	Name of the EtherCAT device	STRING	EPP9022-0060

#### Index 1009 Hardware version

Access rights: read only

Subindex (hex)	Name	Description	Unit	Data type	Value
-	Hardware version	Hardware version [▶ 7] of the EtherCAT device	-	STRING	<sup>1)</sup>

#### Index 100A Software version

Access rights: read only

Subindex (hex)	Name	Description	Unit	Data type	Value
-	Software version	Firmware version [▶ 7] of the EtherCAT device	-	STRING	<sup>1)</sup>

#### Index 1011 Restore default parameters

Access rights: read/write

Subindex (hex)	Name	Description	Data type	Default
1	Subindex 001	Resets the CoE parameters to the factory settings. To do this, write the value 0x64616F6C in this parameter.	UDINT	0

#### Index 1018 Identity

Access rights: read only

Subindex (hex)	Name	Description	Data type	Value
01	Vendor ID	Vendor identifier (2 = Beckhoff Automation)	UDINT	2
02	Product code	Product code	UDINT	1685584361 <sub>dec</sub>
03	Revision	Bit 0 ... 15: Index number of the product variant Bit 16 ... 31: Revision of the device description (ESI)	UDINT	Bit 0 ... 15: 0060 <sub>dec</sub>
04	Serial number	(not used)	UDINT	0

#### Index 10F0 Backup parameter handling

Access rights: read only

Subindex (hex)	Name	Description	Data type	Value
01	Checksum	Checksum of the backup parameters. Backup parameters are the CoE objects whose content is reset to the factory setting by the CoE index <a href="#">1011</a> [ <a href="#">▶ 44</a> ].	UDINT	11102 <sub>dec</sub>

## 7 Appendix

### 7.1 General operating conditions

#### Protection degrees (IP-Code)

The standard IEC 60529 (DIN EN 60529) defines the degrees of protection in different classes.

1. Number: dust protection and touch guard	Definition
0	Non-protected
1	Protected against access to hazardous parts with the back of a hand. Protected against solid foreign objects of Ø 50 mm
2	Protected against access to hazardous parts with a finger. Protected against solid foreign objects of Ø 12.5 mm.
3	Protected against access to hazardous parts with a tool. Protected against solid foreign objects Ø 2.5 mm.
4	Protected against access to hazardous parts with a wire. Protected against solid foreign objects Ø 1 mm.
5	Protected against access to hazardous parts with a wire. Dust-protected. Intrusion of dust is not totally prevented, but dust shall not penetrate in a quantity to interfere with satisfactory operation of the device or to impair safety.
6	Protected against access to hazardous parts with a wire. Dust-tight. No intrusion of dust.
2. Number: water* protection	Definition
0	Non-protected
1	Protected against water drops
2	Protected against water drops when enclosure tilted up to 15°.
3	Protected against spraying water. Water sprayed at an angle up to 60° on either side of the vertical shall have no harmful effects.
4	Protected against splashing water. Water splashed against the disclosure from any direction shall have no harmful effects
5	Protected against water jets
6	Protected against powerful water jets
7	Protected against the effects of temporary immersion in water. Intrusion of water in quantities causing harmful effects shall not be possible when the enclosure is temporarily immersed in water for 30 min. in 1 m depth.

\*) These protection classes define only protection against water.

#### Chemical Resistance

The Resistance relates to the Housing of the IP67 modules and the used metal parts. In the table below you will find some typical resistance.

Character	Resistance
Steam	at temperatures >100°C: not resistant
Sodium base liquor (ph-Value > 12)	at room temperature: resistant > 40°C: not resistant
Acetic acid	not resistant
Argon (technical clean)	resistant

#### Key

- resistant: Lifetime several months
- non inherently resistant: Lifetime several weeks
- not resistant: Lifetime several hours resp. early decomposition

## 7.2 Accessories

### Mounting

Ordering information	Description	Link
ZS5300-0011	Mounting rail	<a href="#">Website</a>

### Cables

A complete overview of pre-assembled cables for fieldbus components can be found [here](#).

Ordering information	Description	Link
ZK2020-3xxx-xxxx	Power cable M8, 4-pin	<a href="#">Website</a>
ZK700x-xxxx-xxxx	EtherCAT P cable M8	<a href="#">Website</a>

### Labeling material, protective caps

Ordering information	Description
ZS5000-0010	Protective cap for M8 sockets, IP67 (50 pieces)
ZS5000-0012	Protective cap for M8 sockets, P-coded, IP67 (50 pieces)
ZS5100-0000	Inscription labels, unprinted, 4 strips of 10
ZS5000-xxxx	Printed inscription labels on enquiry

### Tools

Ordering information	Description
ZB8801-0000	Torque wrench for plugs, 0.4...1.0 Nm
ZB8801-0001	Torque cable key for M8 / wrench size 9 for ZB8801-0000



#### Further accessories

Further accessories can be found in the price list for fieldbus components from Beckhoff and online at <https://www.beckhoff.com>.

## 7.3 Version identification of EtherCAT devices

### 7.3.1 General notes on marking

#### Designation

A Beckhoff EtherCAT device has a 14-digit designation, made up of

- family key
- type
- version
- revision

Example	Family	Type	Version	Revision
EL3314-0000-0016	EL terminal (12 mm, non-pluggable connection level)	3314 (4-channel thermocouple terminal)	0000 (basic type)	0016
ES3602-0010-0017	ES terminal (12 mm, pluggable connection level)	3602 (2-channel voltage measurement)	0010 (high-precision version)	0017
CU2008-0000-0000	CU device	2008 (8-port fast ethernet switch)	0000 (basic type)	0000

#### Notes

- The elements mentioned above result in the **technical designation**. EL3314-0000-0016 is used in the example below.
- EL3314-0000 is the order identifier, in the case of “-0000” usually abbreviated to EL3314. “-0016” is the EtherCAT revision.
- The **order identifier** is made up of
  - family key (EL, EP, CU, ES, KL, CX, etc.)
  - type (3314)
  - version (-0000)
- The **revision** -0016 shows the technical progress, such as the extension of features with regard to the EtherCAT communication, and is managed by Beckhoff.  
In principle, a device with a higher revision can replace a device with a lower revision, unless specified otherwise, e.g. in the documentation.  
Associated and synonymous with each revision there is usually a description (ESI, EtherCAT Slave Information) in the form of an XML file, which is available for download from the Beckhoff web site.  
From 2014/01 the revision is shown on the outside of the IP20 terminals, see Fig. “EL5021 EL terminal, standard IP20 IO device with batch number and revision ID (since 2014/01)”.
- The type, version and revision are read as decimal numbers, even if they are technically saved in hexadecimal.



### 7.3.2 Version identification of IP67 modules

The serial number/ data code for Beckhoff IO devices is usually the 8-digit number printed on the device or on a sticker. The serial number indicates the configuration in delivery state and therefore refers to a whole production batch, without distinguishing the individual modules of a batch.

Structure of the serial number: **KK YY FF HH**

KK - week of production (CW, calendar week)  
 YY - year of production  
 FF - firmware version  
 HH - hardware version

Example with serial number 12 06 3A 02:

12 - production week 12  
 06 - production year 2006  
 3A - firmware version 3A  
 02 - hardware version 02

Exceptions can occur in the **IP67 area**, where the following syntax can be used (see respective device documentation):

Syntax: D ww yy x y z u

D - prefix designation  
 ww - calendar week  
 yy - year  
 x - firmware version of the bus PCB  
 y - hardware version of the bus PCB  
 z - firmware version of the I/O PCB  
 u - hardware version of the I/O PCB

Example: D.22081501 calendar week 22 of the year 2008 firmware version of bus PCB: 1 hardware version of bus PCB: 5 firmware version of I/O PCB: 0 (no firmware necessary for this PCB) hardware version of I/O PCB: 1

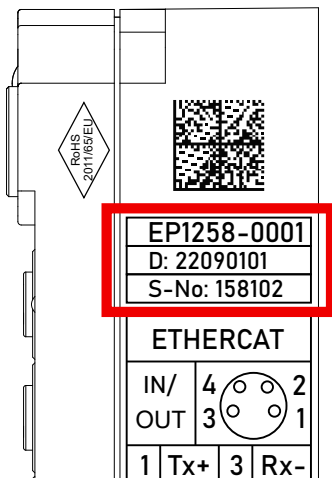

Fig. 10: EP1258-00001 IP67 EtherCAT Box with batch number/DateCode 22090101 and unique serial number 158102

### 7.3.3 Beckhoff Identification Code (BIC)

The Beckhoff Identification Code (BIC) is increasingly being applied to Beckhoff products to uniquely identify the product. The BIC is represented as a Data Matrix Code (DMC, code scheme ECC200), the content is based on the ANSI standard MH10.8.2-2016.

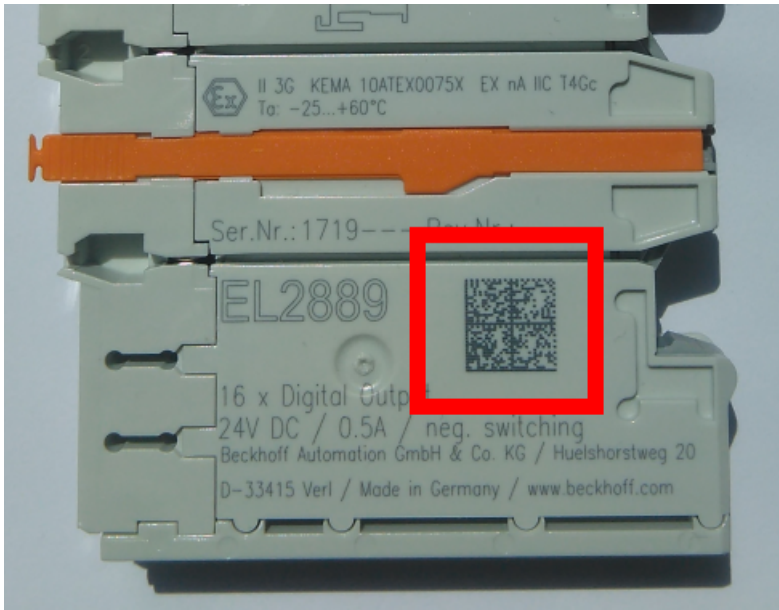

Fig. 11: BIC as data matrix code (DMC, code scheme ECC200)

The BIC will be introduced step by step across all product groups.

Depending on the product, it can be found in the following places:

- on the packaging unit
- directly on the product (if space suffices)
- on the packaging unit and the product

The BIC is machine-readable and contains information that can also be used by the customer for handling and product management.

Each piece of information can be uniquely identified using the so-called data identifier (ANSI MH10.8.2-2016). The data identifier is followed by a character string. Both together have a maximum length according to the table below. If the information is shorter, spaces are added to it.

Following information is possible, positions 1 to 4 are always present, the other according to need of production:

Position	Type of information	Explanation	Data identifier	Number of digits incl. data identifier	Example
1	Beckhoff order number	<b>Beckhoff order number</b>	1P	8	<b>1P</b> 072222
2	Beckhoff Traceability Number (BTN)	<b>Unique serial number, see note below</b>	SBTN	12	<b>SBTN</b> k4p562d7
3	Article description	<b>Beckhoff article description, e.g. EL1008</b>	1K	32	<b>1K</b> EL1809
4	Quantity	<b>Quantity in packaging unit, e.g. 1, 10, etc.</b>	Q	6	<b>Q</b> 1
5	Batch number	Optional: Year and week of production	2P	14	<b>2P</b> 401503180016
6	ID/serial number	Optional: Present-day serial number system, e.g. with safety products	51S	12	<b>51S</b> 678294
7	Variant number	Optional: Product variant number on the basis of standard products	30P	32	<b>30P</b> F971, 2*K183
...					

Further types of information and data identifiers are used by Beckhoff and serve internal processes.

**Structure of the BIC**

Example of composite information from positions 1 to 4 and with the above given example value on position 6. The data identifiers are highlighted in bold font:

**1P**072222**SBTN**k4p562d7**1K**EL1809 **Q**1 **51S**678294

Accordingly as DMC:



Fig. 12: Example DMC **1P**072222**SBTN**k4p562d7**1K**EL1809 **Q**1 **51S**678294

**BTN**

An important component of the BIC is the Beckhoff Traceability Number (BTN, position 2). The BTN is a unique serial number consisting of eight characters that will replace all other serial number systems at Beckhoff in the long term (e.g. batch designations on IO components, previous serial number range for safety products, etc.). The BTN will also be introduced step by step, so it may happen that the BTN is not yet coded in the BIC.

<b>NOTE</b>
This information has been carefully prepared. However, the procedure described is constantly being further developed. We reserve the right to revise and change procedures and documentation at any time and without prior notice. No claims for changes can be made from the information, illustrations and descriptions in this information.

## 7.3.4 Electronic access to the BIC (eBIC)

### Electronic BIC (eBIC)

The Beckhoff Identification Code (BIC) is applied to the outside of Beckhoff products in a visible place. If possible, it should also be electronically readable.

Decisive for the electronic readout is the interface via which the product can be electronically addressed.

### K-bus devices (IP20, IP67)

Currently, no electronic storage and readout is planned for these devices.

### EtherCAT devices (IP20, IP67)

All Beckhoff EtherCAT devices have a so-called ESI-EEPROM, which contains the EtherCAT identity with the revision number. Stored in it is the EtherCAT slave information, also colloquially known as ESI/XML configuration file for the EtherCAT master. See the corresponding chapter in the EtherCAT system manual ([Link](#)) for the relationships.

The eBIC is also stored in the ESI-EEPROM. The eBIC was introduced into the Beckhoff I/O production (terminals, box modules) from 2020; widespread implementation is expected in 2021.

The user can electronically access the eBIC (if existent) as follows:

- With all EtherCAT devices, the EtherCAT master (TwinCAT) can read the eBIC from the ESI-EEPROM
  - From TwinCAT 3.1 build 4024.11, the eBIC can be displayed in the online view.
  - To do this, check the checkbox "Show Beckhoff Identification Code (BIC)" under EtherCAT → Advanced Settings → Diagnostics:

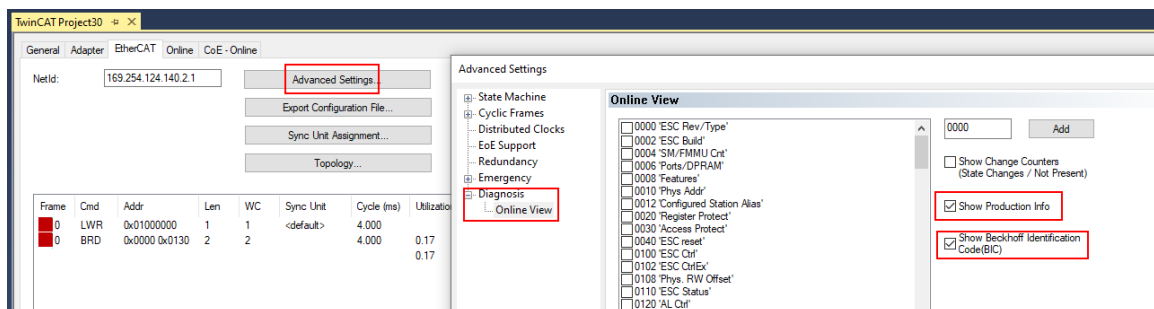

- The BTN and its contents are then displayed:

No	Addr	Name	State	CRC	Fw	Hw	Production Data	ItemNo	BTN	Description	Quantity	BatchNo	SerialNo
1	1001	Term 1 (EK1100)	OP	0,0	0	0	---						
2	1002	Term 2 (EL1018)	OP	0,0	0	0	2020 KW36 Fr	072222	k4p562d7	EL1809	1		678294
3	1003	Term 3 (EL3204)	OP	0,0	7	6	2012 KW24 Sa						
4	1004	Term 4 (EL2004)	OP	0,0	0	0	---	072223	k4p562d7	EL2004	1		678295
5	1005	Term 5 (EL1008)	OP	0,0	0	0	---						
6	1006	Term 6 (EL2008)	OP	0,0	0	12	2014 KW14 Mo						
7	1007	Term 7 (EK1110)	OP	0	1	8	2012 KW25 Mo						

- Note: as can be seen in the illustration, the production data HW version, FW version and production date, which have been programmed since 2012, can also be displayed with "Show Production Info".
- From TwinCAT 3.1. build 4024.24 the functions *FB\_EcReadBIC* and *FB\_EcReadBTN* for reading into the PLC and further eBIC auxiliary functions are available in the Tc2\_EtherCAT Library from v3.3.19.0.
- In the case of EtherCAT devices with CoE directory, the object 0x10E2:01 can additionally be used to display the device's own eBIC; the PLC can also simply access the information here:

- The device must be in PREOP/SAFEOP/OP for access:

Index	Name	Flags	Value
1000	Device type	RO	0x015E1389 (22942601)
1008	Device name	RO	ELM3704-0000
1009	Hardware version	RO	00
100A	Software version	RO	01
100B	Bootloader version	RO	J0.1.27.0
1011:0	Restore default parameters	RO	> 1 <
1018:0	Identity	RO	> 4 <
10E2:0	Manufacturer-specific Identification C...	RO	> 1 <
10E2:01	SubIndex 001	RO	1P158442SBTN0008jekp1KELM3704 Q1 2P482001000016
10F0:0	Backup parameter handling	RO	> 1 <
10F3:0	Diagnosis History	RO	> 21 <
10F8	Actual Time Stamp	RO	0x170bfb277e

- the object 0x10E2 will be introduced into stock products in the course of a necessary firmware revision.
- From TwinCAT 3.1. build 4024.24 the functions *FB\_EcCoEReadBIC* and *FB\_EcCoEReadBTN* for reading into the PLC and further eBIC auxiliary functions are available in the Tc2\_EtherCAT Library from v3.3.19.0.
- Note: in the case of electronic further processing, the BTN is to be handled as a string(8); the identifier "SBTN" is not part of the BTN.
- Technical background  
The new BIC information is additionally written as a category in the ESI-EEPROM during the device production. The structure of the ESI content is largely dictated by the ETG specifications, therefore the additional vendor-specific content is stored with the help of a category according to ETG.2010. ID 03 indicates to all EtherCAT masters that they must not overwrite these data in case of an update or restore the data after an ESI update.  
The structure follows the content of the BIC, see there. This results in a memory requirement of approx. 50..200 bytes in the EEPROM.
- Special cases
  - If multiple, hierarchically arranged ESCs are installed in a device, only the top-level ESC carries the eBIC Information.
  - If multiple, non-hierarchically arranged ESCs are installed in a device, all ESCs carry the eBIC Information.
  - If the device consists of several sub-devices with their own identity, but only the top-level device is accessible via EtherCAT, the eBIC of the top-level device is located in the CoE object directory 0x10E2:01 and the eBICs of the sub-devices follow in 0x10E2:nn.

**Profibus/Profinet/DeviceNet... Devices**

Currently, no electronic storage and readout is planned for these devices.

## 7.4 Support and Service

Beckhoff and their partners around the world offer comprehensive support and service, making available fast and competent assistance with all questions related to Beckhoff products and system solutions.

### Beckhoff's branch offices and representatives

Please contact your Beckhoff branch office or representative for local support and service on Beckhoff products!

The addresses of Beckhoff's branch offices and representatives round the world can be found on her internet pages: [www.beckhoff.com](http://www.beckhoff.com)

You will also find further documentation for Beckhoff components there.

### Support

The Beckhoff Support offers you comprehensive technical assistance, helping you not only with the application of individual Beckhoff products, but also with other, wide-ranging services:

- support
- design, programming and commissioning of complex automation systems
- and extensive training program for Beckhoff system components

Hotline: +49 5246 963 157  
e-mail: [support@beckhoff.com](mailto:support@beckhoff.com)  
web: [www.beckhoff.com/support](http://www.beckhoff.com/support)

### Service

The Beckhoff Service Center supports you in all matters of after-sales service:

- on-site service
- repair service
- spare parts service
- hotline service

Hotline: +49 5246 963 460  
e-mail: [service@beckhoff.com](mailto:service@beckhoff.com)  
web: [www.beckhoff.com/service](http://www.beckhoff.com/service)

### Headquarters Germany

Beckhoff Automation GmbH & Co. KG

Hülshorstweg 20  
33415 Verl  
Germany

Phone: +49 5246 963 0  
e-mail: [info@beckhoff.com](mailto:info@beckhoff.com)  
web: [www.beckhoff.com](http://www.beckhoff.com)



More Information:  
[www.beckhoff.com/epp9022-0060/](http://www.beckhoff.com/epp9022-0060/)

Beckhoff Automation GmbH & Co. KG  
Hülshorstweg 20  
33415 Verl  
Germany  
Phone: +49 5246 9630  
[info@beckhoff.com](mailto:info@beckhoff.com)  
[www.beckhoff.com](http://www.beckhoff.com)

