

Documentation | EN

EPP7342-0002

2-channel motion interface, DC motor, 48 V DC, 3.5 A



Table of contents

1 Foreword	5
1.1 Notes on the documentation	5
1.2 Safety instructions	6
1.3 Documentation issue status	7
2 Product group: EtherCAT P Box modules	8
3 Product overview	9
3.1 Introduction	9
3.2 Technical data	10
3.3 Scope of supply.....	11
3.4 Technology.....	12
4 Mounting and connection	14
4.1 Mounting	14
4.1.1 Dimensions	14
4.1.2 Fixing.....	15
4.1.3 Tightening torques for plug connectors.....	15
4.1.4 Functional earth (FE)	15
4.2 Connection	16
4.2.1 EtherCAT P	16
4.2.2 Signal connection.....	20
4.3 Disposal	22
5 Commissioning/Configuration	23
5.1 Integrating into a TwinCAT project.....	23
5.2 Integration into the NC configuration (manually).....	23
5.3 Settings in the CoE register	26
5.3.1 Adaptation of current and voltage	26
5.3.2 Adaptation of the encoder data	27
5.3.3 Adaptation of the maximal velocity.....	28
5.3.4 Selection of the operating mode	29
5.3.5 Select info data	30
5.3.6 KA factor	31
5.4 NC settings.....	32
5.4.1 Reference velocity selection	32
5.4.2 Dead time compensation	33
5.4.3 Scaling factor	34
5.4.4 Position lag monitoring.....	35
5.4.5 KV factors.....	36
5.5 Commissioning the motor with the NC.....	37
5.6 Operating modes.....	39
5.6.1 Overview	39
5.6.2 Chopper operation	40
5.6.3 Positioning Interface.....	42
5.7 Restore the delivery state	43
5.8 Decommissioning.....	44

6	CoE parameters	45
6.1	Restore object	45
6.2	Configuration data	46
6.3	Command object	55
6.4	Input data	56
6.5	Output data	59
6.6	Information and diagnosis data (channel specific)	62
6.7	Configuration data (vendor-specific)	65
6.8	Information and diagnosis data (device-specific)	66
6.9	Standard objects	67
7	Appendix	87
7.1	General operating conditions	87
7.2	Accessories	88
7.3	Version identification of EtherCAT devices	89
7.3.1	General notes on marking	89
7.3.2	Version identification of IP67 modules	90
7.3.3	Beckhoff Identification Code (BIC)	91
7.3.4	Electronic access to the BIC (eBIC)	93
7.4	Support and Service	95

1 Foreword

1.1 Notes on the documentation

Intended audience

This description is only intended for the use of trained specialists in control and automation engineering who are familiar with the applicable national standards.

It is essential that the documentation and the following notes and explanations are followed when installing and commissioning these components.

The qualified personnel is obliged to always use the currently valid documentation.

The responsible staff must ensure that the application or use of the products described satisfy all the requirements for safety, including all the relevant laws, regulations, guidelines and standards.

Disclaimer

The documentation has been prepared with care. The products described are, however, constantly under development.

We reserve the right to revise and change the documentation at any time and without prior announcement.

No claims for the modification of products that have already been supplied may be made on the basis of the data, diagrams and descriptions in this documentation.

Trademarks

Beckhoff®, TwinCAT®, TwinCAT/BSD®, TC/BSD®, EtherCAT®, EtherCAT G®, EtherCAT G10®, EtherCAT P®, Safety over EtherCAT®, TwinSAFE®, XFC®, XTS® and XPlanar® are registered trademarks of and licensed by Beckhoff Automation GmbH. Other designations used in this publication may be trademarks whose use by third parties for their own purposes could violate the rights of the owners.

Patent Pending

The EtherCAT Technology is covered, including but not limited to the following patent applications and patents: EP1590927, EP1789857, EP1456722, EP2137893, DE102015105702 with corresponding applications or registrations in various other countries.



EtherCAT® is registered trademark and patented technology, licensed by Beckhoff Automation GmbH, Germany.

Copyright

© Beckhoff Automation GmbH & Co. KG, Germany.

The reproduction, distribution and utilization of this document as well as the communication of its contents to others without express authorization are prohibited.

Offenders will be held liable for the payment of damages. All rights reserved in the event of the grant of a patent, utility model or design.

1.2 Safety instructions

Safety regulations

Please note the following safety instructions and explanations!
Product-specific safety instructions can be found on following pages or in the areas mounting, wiring, commissioning etc.

Exclusion of liability

All the components are supplied in particular hardware and software configurations appropriate for the application. Modifications to hardware or software configurations other than those described in the documentation are not permitted, and nullify the liability of Beckhoff Automation GmbH & Co. KG.

Personnel qualification

This description is only intended for trained specialists in control, automation and drive engineering who are familiar with the applicable national standards.

Signal words

The signal words used in the documentation are classified below. In order to prevent injury and damage to persons and property, read and follow the safety and warning notices.

Personal injury warnings

⚠ DANGER

Hazard with high risk of death or serious injury.

⚠ WARNING

Hazard with medium risk of death or serious injury.

⚠ CAUTION

There is a low-risk hazard that could result in medium or minor injury.

Warning of damage to property or environment

NOTICE

The environment, equipment, or data may be damaged.

Information on handling the product



This information includes, for example:
recommendations for action, assistance or further information on the product.

1.3 Documentation issue status

Version	Comment
1.0	<ul style="list-style-type: none">• First release.

Firmware and hardware versions

This documentation refers to the firmware and hardware version that was applicable at the time the documentation was written.

The module features are continuously improved and developed further. Modules having earlier production statuses cannot have the same properties as modules with the latest status. However, existing properties are retained and are not changed, so that older modules can always be replaced with new ones.

The firmware and hardware version (delivery state) can be found in the batch number (D-number) printed on the side of the EtherCAT Box.

Syntax of the batch number (D-number)

D: WW YY FF HH

WW - week of production (calendar week)

YY - year of production

FF - firmware version

HH - hardware version

Example with D no. 29 10 02 01:

29 - week of production 29

10 - year of production 2010

02 - firmware version 02

01 - hardware version 01

Further information on this topic: [Version identification of EtherCAT devices \[► 89\]](#).

2 Product group: EtherCAT P Box modules

EtherCAT P

EtherCAT P supplements the EtherCAT technology with a process in which communication and supply voltages are transmitted on a common line. All EtherCAT properties are retained with this process.

Two supply voltages are transmitted per EtherCAT P line. The supply voltages are electrically isolated from each other and can therefore be switched individually. The nominal supply voltage for both is $24 V_{DC}$.

EtherCAT P uses the same cable structure as EtherCAT: a 4-core Ethernet cable with M8 connectors. The connectors are mechanically coded so that EtherCAT connectors and EtherCAT P connectors cannot be interchanged.

EtherCAT P Box modules

EtherCAT P Box modules are EtherCAT P slaves with degree of protection IP67. They are designed for operation in wet, dirty or dusty industrial environments.

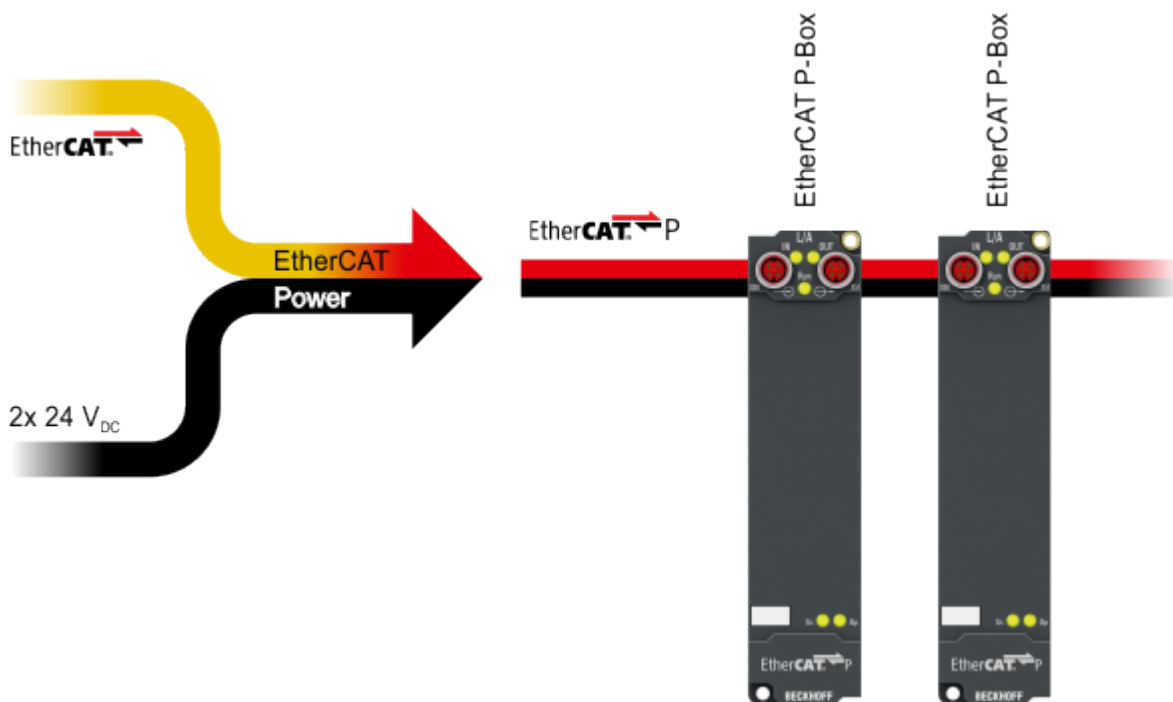

i EtherCAT basics

A detailed description of the EtherCAT system can be found in the [EtherCAT system documentation](#).

3 Product overview

3.1 Introduction

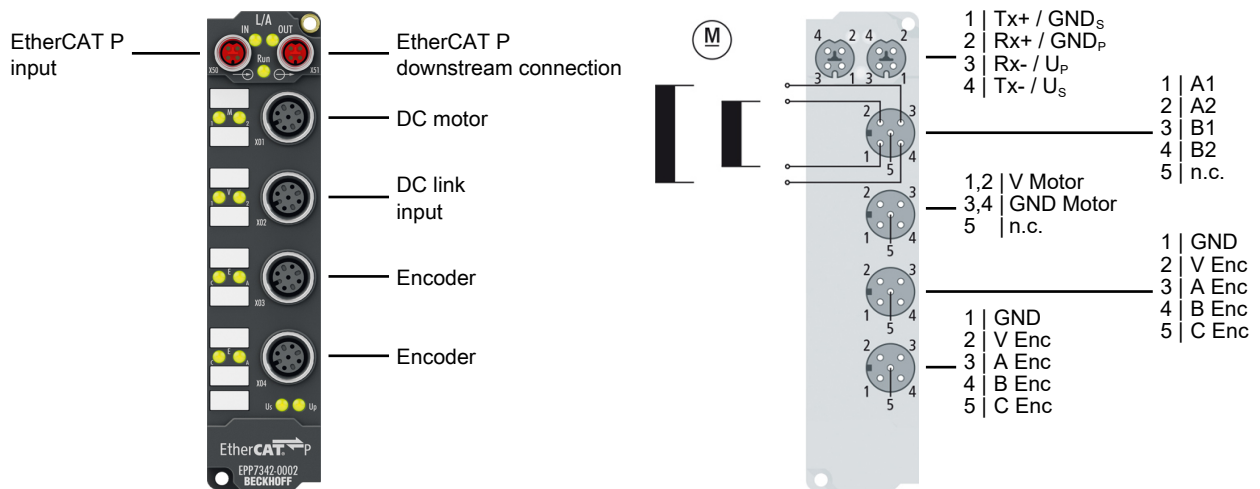

EtherCAT P Box, 2-channel motion interface, DC motor, 48 V_{DC}, 3.5 A, M12, with incremental encoder

The EPP7342-0002 EtherCAT P Box enables direct operation of two DC motors.

The speed or position is specified by the automation device via a 16-bit value. By connection of an incremental encoder (24 V_{DC}, single-ended), a simple servo axis can be realised. The output stage is protected against overload and short-circuit. The EtherCAT P Box has two channels that indicate their signal state via light emitting diodes. The LEDs enable quick local diagnosis.

Quick links

- [Technical data \[▶ 10\]](#)
- [Dimensions \[▶ 14\]](#)
- [Signal interface \[▶ 20\]](#)
- [Commissioning \[▶ 23\]](#)

3.2 Technical data

All values are typical values over the entire temperature range, unless stated otherwise.

EtherCAT P	
Connection	2 x M8 socket, 4-pin, P-coded, red
Distributed Clocks	yes

Supply voltages	
Connection	See EtherCAT P connection
U_S nominal voltage	24 V _{DC} (-15 % / +20 %)
U_S sum current: $I_{S,sum}$	max. 3 A
Current consumption from U_S	100 mA + current consumption of the encoder
U_P nominal voltage	24 V _{DC} (-15 % / +20 %)
U_P sum current: $I_{P,sum}$	max. 3 A
Current consumption from U_P	None. U_P is only forwarded.
Electrical isolation	GND _S , GND _P and "GND Motor" are electrically isolated from each other.

Motor channels	
Number	2
Motor type	DC brush motor, inductive
Connection	1x M12 common socket for both motors
Cable length	max. 30 m
Motor supply	8 ... 48 V _{DC}
Motor supply connection	1 x M12 socket
Nominal current per channel	3.5 A, short-circuit proof
Overload protection	Thermal overload warning
Resolution	Current: max. 10 bit Speed: max. 16 bit
PWM clock frequency	30 kHz with 180° phase shift each
PWM duty cycle	0 ... 100% (voltage-controlled)
Current controller frequency	approx. 25 kHz

Encoder inputs	
Number	2
Encoder type	Incremental encoders
Connection	1x M12 socket per encoder
Encoder supply	24 V _{DC} from peripheral voltage U_S , not short-circuit proof
Signals	Single-ended
Signal voltage "0"	-3 ... 1.5 V
Signal voltage "1"	2.5 ... 24 V
Pulse frequency	max. 400,000 increments per second with 4-fold evaluation

Housing data	
Dimensions W x H x D	30 mm x 126 mm x 26.5 mm (without connectors)
Weight	approx. 165 g
Installation position	variable
Material	PA6 (polyamide)

Environmental conditions	
Ambient temperature during operation	-25 ... +60 °C
Ambient temperature during storage	-40 ... +85 °C
Vibration / shock resistance	conforms to EN 60068-2-6 / EN 60068-2-27
EMC immunity / emission	conforms to EN 61000-6-2 / EN 61000-6-4
Protection class	IP65, IP66, IP67 conforms to EN 60529

Approvals / markings	
Approvals / markings *)	CE, UL under preparation

*) Real applicable approvals/markings see type plate on the side (product marking).

Additional tests

The devices have undergone the following additional tests:

Test	Explanation
Vibration	10 frequency sweeps in 3 axes
	5 Hz < f < 60 Hz displacement 0.35 mm, constant amplitude
	60.1 Hz < f < 500 Hz acceleration 5 g, constant amplitude
Shocks	1000 shocks in each direction, in 3 axes
	35 g, 11 ms

3.3 Scope of supply

Make sure that the following components are included in the scope of delivery:

- 1x EPP7342-0002
- 2x protective cap for EtherCAT socket, M8, green (pre-assembled)
- 1x protective cap for supply voltage input, M8, transparent (pre-assembled)
- 1x protective cap for supply voltage output, M8, black (pre-assembled)
- 10x labels, blank (1 strip of 10)

● Pre-assembled protective caps do not ensure IP67 protection

i Protective caps are pre-assembled at the factory to protect connectors during transport. They may not be tight enough to ensure IP67 protection.

Ensure that the protective caps are correctly seated to ensure IP67 protection.

3.4 Technology

EPP7342-0002 integrates a compact Motion Control solution up to 200 W with minimum space requirement.

DC motor

DC motors can replace the considerably more expensive servo motors in many applications if they are operated with an intelligent controller. Since its speed is proportional to the voltage, the DC motor is easy to control in comparison with other motors.

Two output stages for optimum performance

With the EPP7342-0002 EtherCAT P Box a DC motor can easily be integrated into the control system. All parameters are adjustable via the fieldbus. The DC motor output stages for EtherCAT unite a small, compact design with an extensive area of application. Two DC motors can be operated directly with each of the output stages. The EPP7342-0002 also has an integrated feedback system for incremental encoders.

The speed can be easily adjusted via the process data. The integrated compensation of the internal resistance keeps the motor at the desired speed for load changes. The speed is preset by a 16-bit value from the automation device. Thus a simple drive task can be solved using a simple controller.

The EtherCAT P Box has two channels, whose signal states are indicated by LEDs. This enables fast local diagnosis.

Areas of application

Two areas of application are particularly well supported by the output stages:

1. A simple controller with inexpensive processor power and low demands on the cycle time.
By using the integrated path control, the box can carry out independent positioning movements without the use of NC. Only a DC motor and the EtherCAT P Box are required.
2. High-end positioning with integration in TwinCAT NC.
In conjunction with EPP7342-0002, a DC motor is controlled under TwinCAT like a servo terminal. No further changes are necessary.

For demanding positioning tasks a closed speed control loop with a feedback system is needed. The EtherCAT P Box enables connection of an incremental encoder.

The control loop can be closed either by the EtherCAT P Box itself or by the higher-level control system.

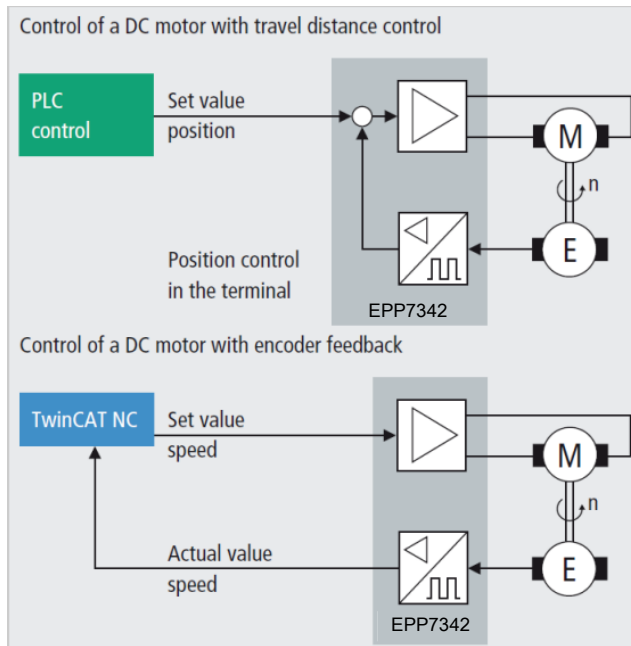

Fig. 1: Implementation options for control loops with EPP7342-0002

The peak current may briefly significantly exceed the nominal current and in this way makes the whole drive system very dynamic. In such dynamic applications, negative acceleration causes energy recovery, which lead to voltage peaks at the power supply unit.

The [EP9576-1032](#) brake chopper box protects against the consequences of overvoltage by absorbing part of the energy. It has an integrated brake resistor that converts surplus energy into heat.

4 Mounting and connection

4.1 Mounting

4.1.1 Dimensions

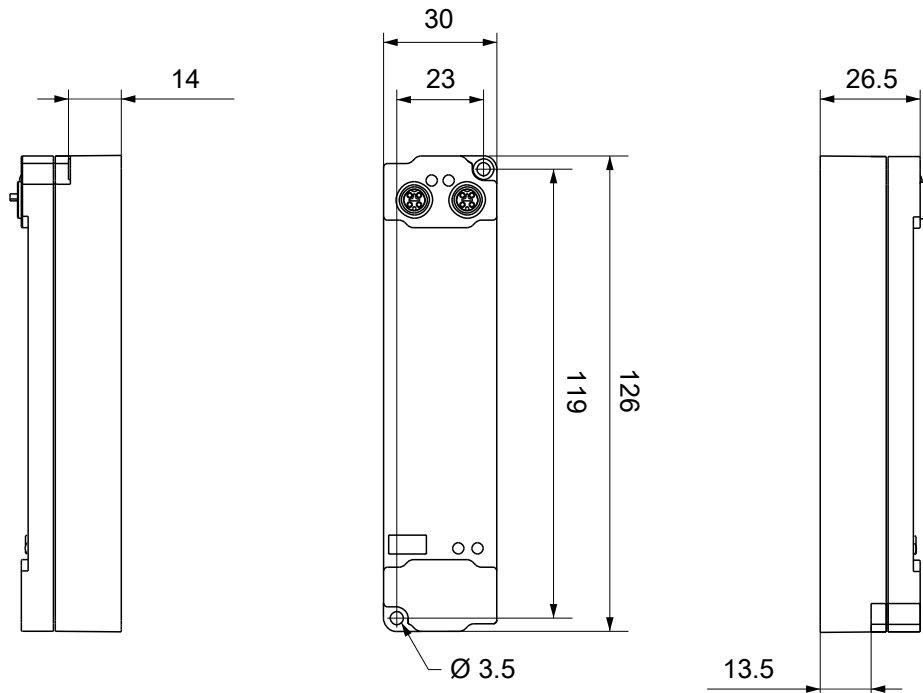

All dimensions are given in millimeters.
The drawing is not true to scale.

Housing features

Housing material	PA6 (polyamide)
Sealing compound	polyurethane
Mounting	two mounting holes $\text{Ø } 3.5$ mm for M3
Metal parts	brass, nickel-plated
Contacts	CuZn, gold-plated
Installation position	variable
Protection class	IP65, IP66, IP67 (conforms to EN 60529) when screwed together
Dimensions (H x W x D)	approx. 126 x 30 x 26.5 mm (without connectors)

4.1.2 Fixing

NOTICE	
Dirt during assembly	
Dirty connectors can lead to malfunctions. Protection class IP67 can only be guaranteed if all cables and connectors are connected.	
<ul style="list-style-type: none"> • Protect the plug connectors against dirt during the assembly. 	

Mount the module with two M3 screws on the mounting holes in the corners of the module. The mounting holes have no thread.

4.1.3 Tightening torques for plug connectors

Screw connectors tight with a torque wrench. (e.g. ZB8801 from Beckhoff)

Connector diameter	Tightening torque
M8	0.4 Nm
M12	0.6 Nm

4.1.4 Functional earth (FE)

The upper mounting holes also serves as a connection for functional earth (FE).

Make sure that the box is grounded to low impedance via the functional earth (FE) connection. You can achieve this, for example, by mounting the box on a grounded machine bed.



Fig. 2: Connection for functional earth (FE)

4.2 Connection

4.2.1 EtherCAT P

⚠ WARNING

Power supply from SELV/PELV power supply unit!

SELV/PELV circuits (Safety Extra Low Voltage, Protective Extra Low Voltage) according to IEC 61010-2-201 must be used to supply the EtherCAT P Power Sourcing Device (PSD).

Notes:

- SELV/PELV circuits may give rise to further requirements from standards such as IEC 60204-1 et al, for example with regard to cable spacing and insulation.
- A SELV (Safety Extra Low Voltage) supply provides safe electrical isolation and limitation of the voltage without a connection to the protective conductor, a PELV (Protective Extra Low Voltage) supply also requires a safe connection to the protective conductor.

EtherCAT P transmits two supply voltages:

- **Control voltage U_S**
The following sub-functions are supplied from the control voltage U_S :
 - the fieldbus
 - the processor logic
 - typically the inputs and the sensors if the EtherCAT P Box has inputs.
- **Peripheral voltage U_P**
The digital outputs are typically supplied from the peripheral voltage U_P for EtherCAT P Box modules with digital outputs. U_P can be supplied separately. If U_P is switched off, the fieldbus function, the function of the inputs and the supply of the sensors are maintained.

The exact assignment of U_S and U_P can be found in the pin assignment of the I/O connections.

Redirection of the supply voltages

The supply voltages are passed on internally from the "IN" connection to the "OUT" connection. Hence, the supply voltages U_S and U_P can be passed from one EtherCAT P Box to the next EtherCAT P Box in a simple manner.

NOTICE

Note the maximum current.

Ensure that the maximum permitted current of 3 A for the M8 connectors is not exceeded when redirecting EtherCAT P.

4.2.1.1 Connectors

NOTICE

Risk of damage to the device!

Bring the EtherCAT/EtherCAT P system into a safe, powered down state before starting installation, disassembly or wiring of the modules!

Two M8 sockets at the upper end of the modules are provided for supply and downstream connection of EtherCAT P:

- IN: left M8 socket for EtherCAT P supply
- OUT: right M8 socket for downstream connection of EtherCAT P

The metal threads of the M8 EtherCAT P sockets are internally linked to the FE connection via high impedance RC combination. See chapter [Functional earth \(FE\)](#) [► 15].



Fig. 3: Connectors for EtherCAT P

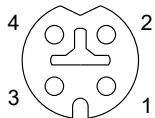

Fig. 4: M8 socket, p-coded

Contact	Signal	Voltage	Core color ¹⁾
1	Tx +	GND _S	yellow
2	Rx +	GND _P	white
3	Rx -	U _P : peripheral voltage, +24 V _{DC}	blue
4	Tx -	U _S : control voltage, +24 V _{DC}	orange
Housing	Shield	Shield	Shield

¹⁾ The core colors apply to EtherCAT P cables and ECP cables from Beckhoff.

4.2.1.2 Status LEDs

4.2.1.2.1 Supply voltages



EtherCAT P Box modules indicate the status of the supply voltages via two status LEDs. The status LEDs are labeled with the designations of the supply voltages: U_s and U_p .

LED	Display	Meaning
U_s (control voltage)	off	The supply voltage U_s is not available.
	green illuminated	The supply voltage U_s is available.
U_p (peripheral voltage)	off	The supply voltage U_p is not available.
	green illuminated	The supply voltage U_p is available.

4.2.1.2.2 EtherCAT



L/A (Link/Act)

A green LED labeled "L/A" or "Link/Act" is located next to each EtherCAT/EtherCAT P socket. The LED indicates the communication state of the respective socket:

LED	Meaning
off	no connection to the connected EtherCAT device
lit	LINK: connection to the connected EtherCAT device
flashes	ACT: communication with the connected EtherCAT device

Run

Each EtherCAT slave has a green LED labelled "Run". The LED signals the status of the slave in the EtherCAT network:

LED	Meaning
off	Slave is in "Init" state
flashes uniformly	Slave is in "Pre-Operational" state
flashes sporadically	Slave is in "Safe-Operational" state
lit	Slave is in "Operational" state

Description of the EtherCAT slave states

4.2.1.3 Conductor losses

Take into account the voltage drop on the supply line when planning a system. Avoid the voltage drop being so high that the supply voltage at the box lies below the minimum nominal voltage. Variations in the voltage of the power supply unit must also be taken into account.

i Planning tool for EtherCAT P

You can plan cable lengths, voltages and currents of your EtherCAT P system using TwinCAT 3. The requirement for this is TwinCAT 3 Build 4020 or higher.

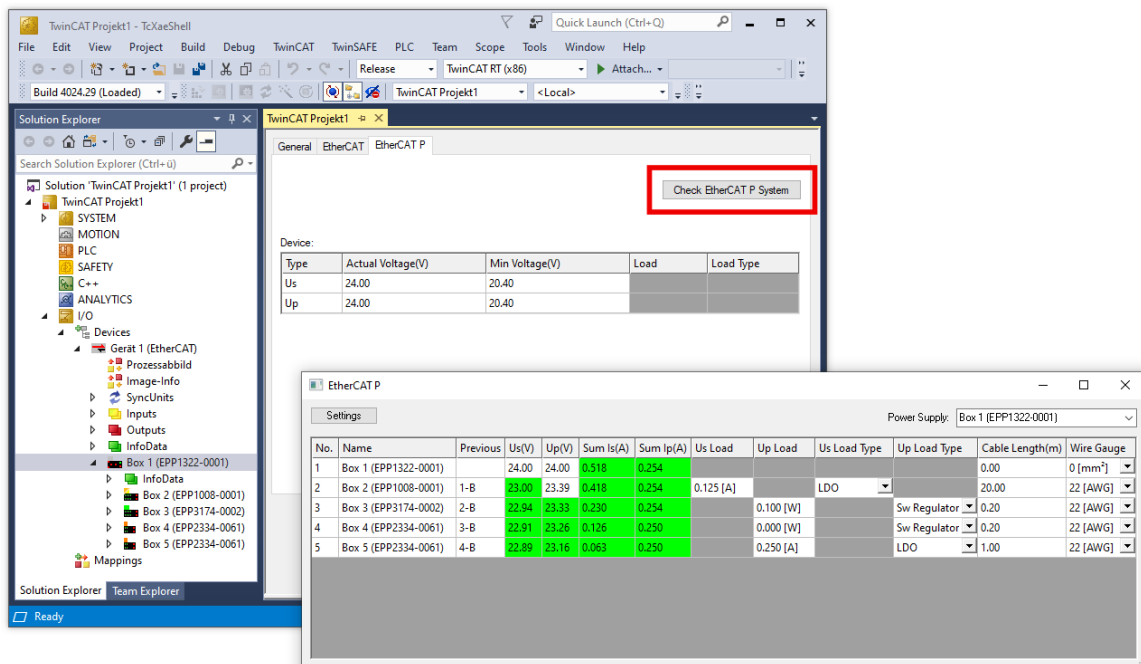

Further information can be found in the quick start guide [IO configuration in TwinCAT](#) in chapter "Configuration of EtherCAT P via TwinCAT".

Voltage drop on the supply line

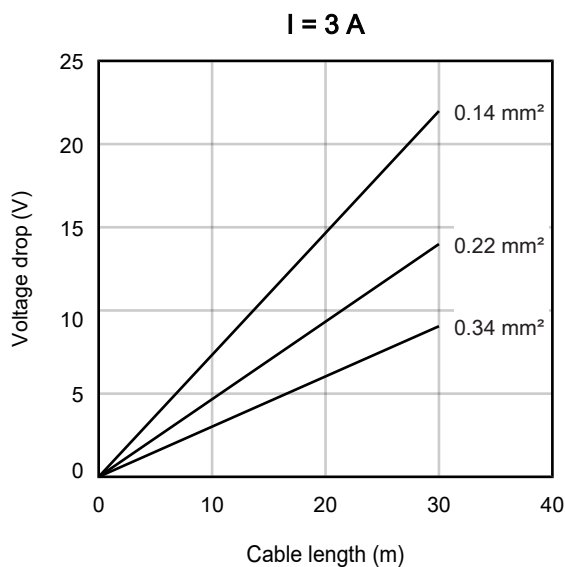

4.2.2 Signal connection

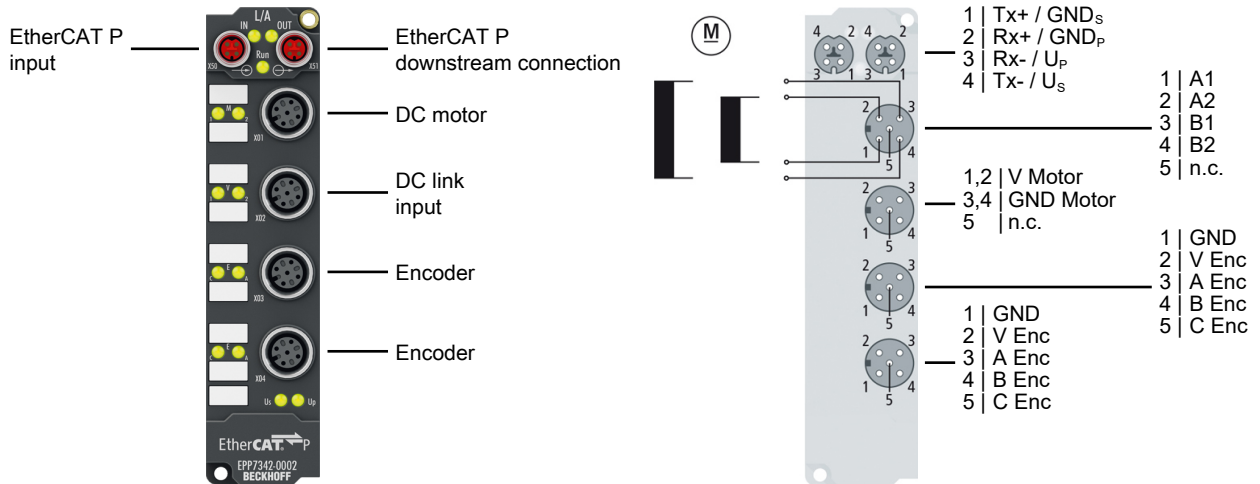

NOTICE

Note the numbering of the M12 sockets

Mixing up the M12 connectors can damage the module.

M12 socket no. 1: DC motor connection

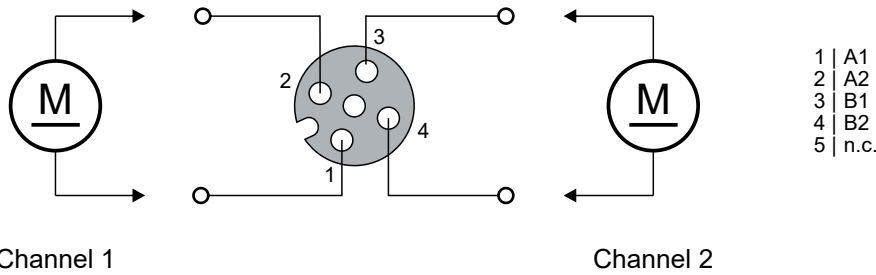

M12 socket no. 2: connection for motor supply

NOTICE

The motor supply is not protected against polarity reversal

Defect possible through polarity reversal.

- Ensure that the polarity is correct.

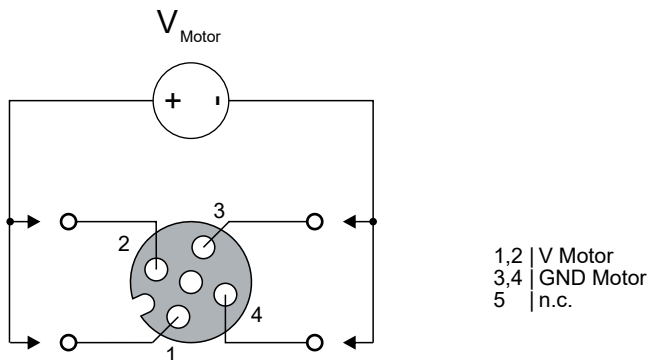

M12 sockets no. 3 and no. 4: encoder connection

NOTICE

The encoder supply is not short-circuit proof

Risk of defect.

- Avoid short-circuiting the encoder supply.

NOTICE

Incorrect signal levels due to electromagnetic interference

The encoder inputs are optimized for fast signal transmission and are therefore susceptible to electromagnetic interference.

Under the influence of electromagnetic interference, a false signal level can be detected.

- If necessary, use shielded signal lines.

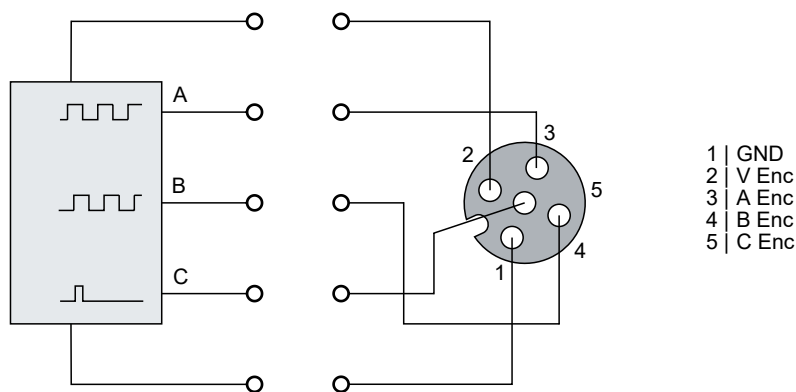

4.3 Disposal



Products marked with a crossed-out wheeled bin shall not be discarded with the normal waste stream. The device is considered as waste electrical and electronic equipment. The national regulations for the disposal of waste electrical and electronic equipment must be observed.

5 Commissioning/Configuration

5.1 Integrating into a TwinCAT project

The procedure for integration in a TwinCAT project is described in these [Quick start guide](#).

5.2 Integration into the NC configuration (manually)

(TwinCAT 3.1)

✓ Prerequisite: an EPP7342-0002 is integrated in a TwinCAT project.

1. Right click on "MOTION" and select "Add New Item..." .

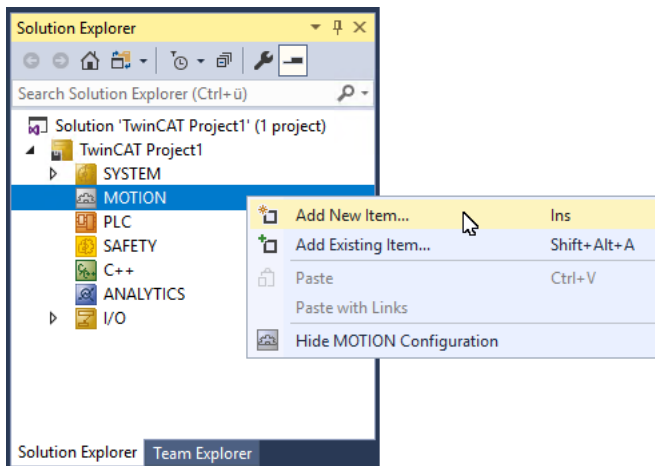

⇒ A new NC task is created.

2. Right click on "Axes" and select "Add New Item".

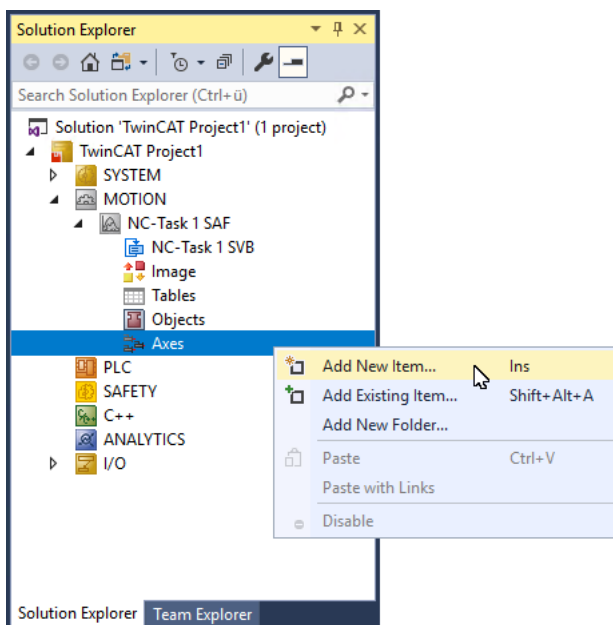

⇒ A dialog box appears:

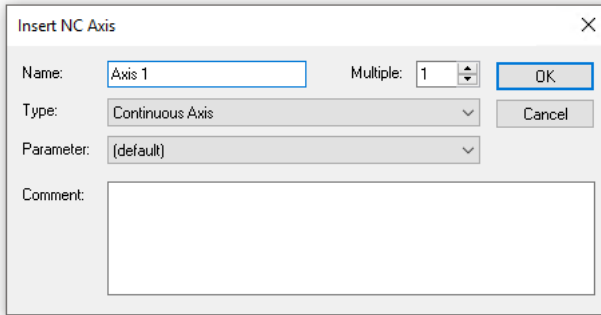

3. In the field "Type" select the entry "Continuous axis" and confirm with "OK".
4. Double-click the new axis.
5. Click on the "Settings" tab.
6. Click on the button "Link To I/O..." .

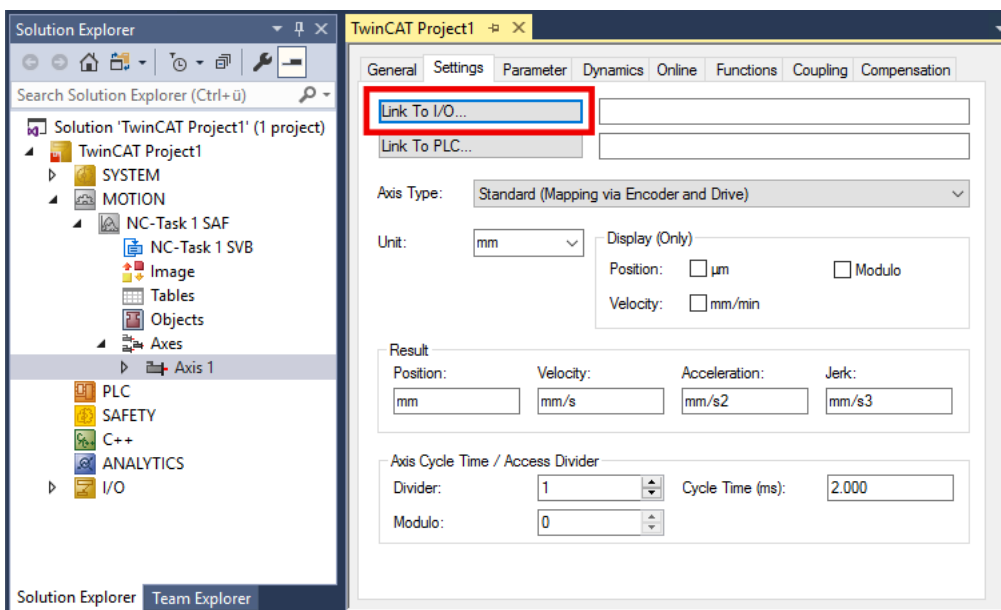

⇒ A dialog box appears. It shows the available motor channels.

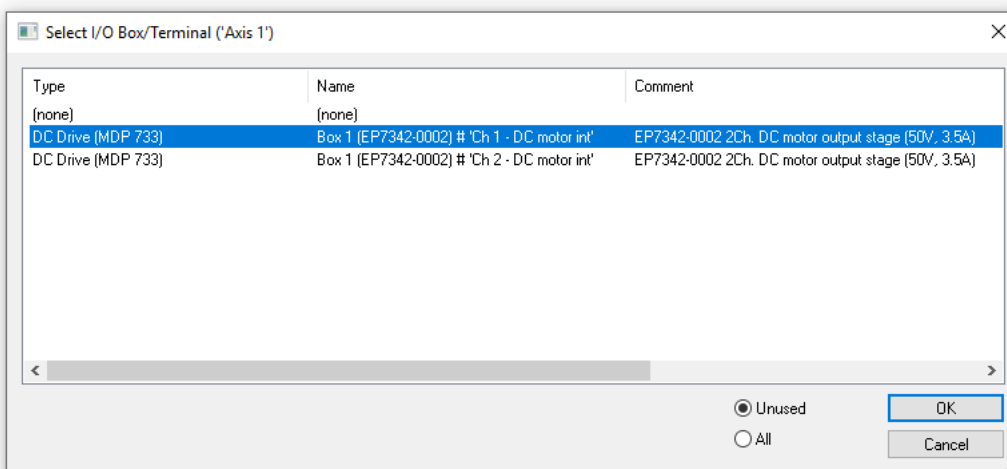

7. Select the appropriate entry and confirm with "OK".
The assignment of the connector pins to the motor channels can be found in chapter [Signal connection](#) [▶ 20].

⇒ The process data are linked to the NC task.

You need to set some parameters before you can start the motor. You will find these parameters in the following chapters:

- [Settings in the CoE register \[▶ 26\]](#)
- [NC settings \[▶ 32\]](#)

5.3 Settings in the CoE register

The data given here exemplary for a DC motor type GR42X25 from the company Dunkermotoren. For other motors the values may vary, depending on the application.

5.3.1 Adaptation of current and voltage

NOTICE

Risk of material damage due to incorrect configuration

Incorrect configuration can cause damage due to overcurrent.

- Do not set the nominal current higher than 3500 (equivalent to 3.5 A)
- Do not set the peak current higher than 5000 (corresponds to 5.0 A)

NOTICE

The motor may overheat

In order to prevent overheating of the connected motor it is important to adapt the current and voltage output of the box to the motor.

Index 0x8020:02 "Nominal current" and index 0x8020:03 "Nominal voltage" have be set appropriately in the CoE register. In addition, you should also adapt the "Maximal current" in the index 0x8020:01 and the coil resistance of the motor in the index 0x8020:04 "Motor coil resistance" to the connected motor.

Reducedcurrent can be set in index 0x8020:05 and 0x8020:06. This reduces the coil current when at a standstill (and therefore the power dissipation). Please note that this reduces the torque.

Index	Name	Flags	Value	Unit
8000:0	ENC Settings Ch.1	RW	> 14 <	
8010:0	ENC Settings Ch.2	RW	> 14 <	
8020:0	DCM Motor Settings Ch.1	RW	> 15 <	
8020:01	Maximal current	RW	0x1388 (5000)	
8020:02	Nominal current	RW	0x0DAC (3500)	
8020:03	Nominal voltage	RW	0xC350 (50000)	
8020:04	Motor coil resistance	RW	0x0064 (100)	
8020:05	Reduced current (positive)	RW	0x07D0 (2000)	
8020:06	Reduced current (negative)	RW	0x07D0 (2000)	
8020:07	Encoder increments (4-fold)	RW	0x0000 (0)	
8020:08	Maximal motor velocity	RW	0x0000 (0)	
8020:0C	Time for switch-off at overload	RW	0x00C8 (200)	
8020:0D	Time for current lowering at overload	RW	0x07D0 (2000)	
8020:0E	Torque auto-reduction threshold (posit...	RW	0x00 (0)	
8020:0F	Torque auto-reduction threshold (neg...	RW	0x00 (0)	
8021:0	DCM Controller Settings Ch.1	RW	> 18 <	
8022:0	DCM Features Ch.1	RW	> 54 <	
8023:0	DCM Controller Settings 2 Ch.1	RW	> 8 <	
8030:0	DCM Motor Settings Ch.2	RW	> 15 <	

Fig. 5: Adaptation of current and voltage

5.3.2 Adaptation of the encoder data

Different encoders are available with a different number of increments. You must specify the number of increments of your encoder in the index 0x8020:07 "Encoder increments" (see fig. *Adaptation of the encoder data*). In our example an encoder with 1024 increments is used, corresponding to 4096 increments in the case of quadruple evaluation. The number of increments of your encoder can be found in the data sheet for the encoder.

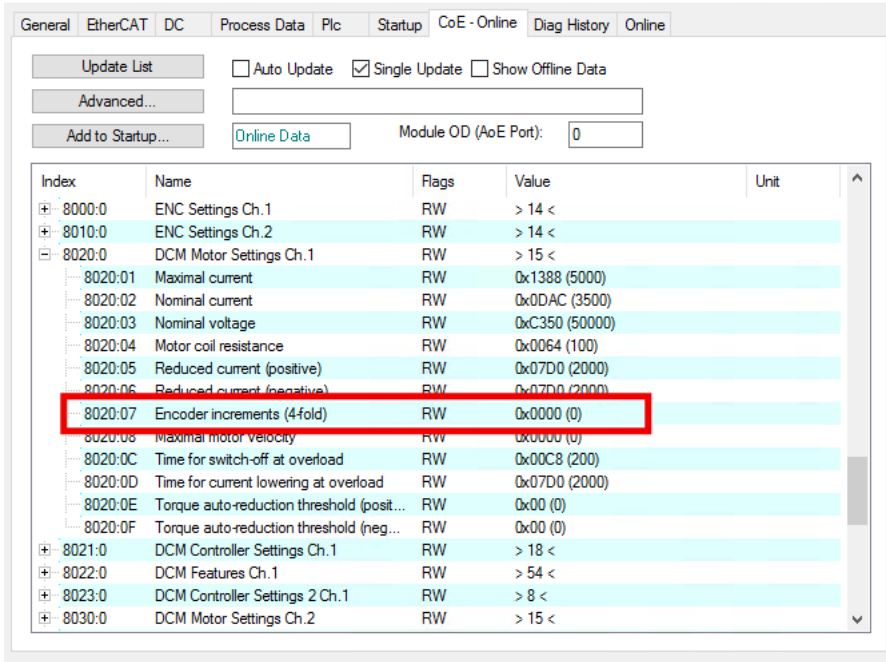
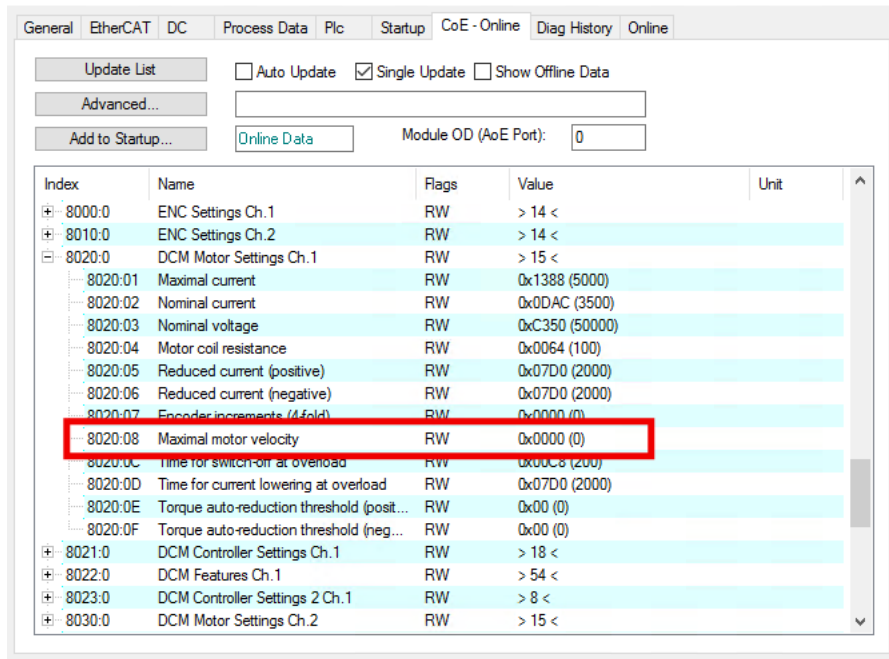

Fig. 6: Adaptation of the encoder data

5.3.3 Adaptation of the maximal velocity

The maximum velocity with which your DC motor can move must be entered in index 0x8020:08 "Maximum motor velocity". You can take this parameter from the name plate on the motor and write it 1:1 into the index. In the example the motor has a maximum velocity of 3600 revolutions per minute.



The screenshot shows the 'CoE - Online' configuration window. The 'Online Data' section is active, displaying a table of parameters. The row for index 8020:08, 'Maximal motor velocity', is highlighted with a red box. The current value is 0x0000 (0).

Index	Name	Flags	Value	Unit
8000:0	ENC Settings Ch.1	RW	> 14 <	
8010:0	ENC Settings Ch.2	RW	> 14 <	
8020:0	DCM Motor Settings Ch.1	RW	> 15 <	
8020:01	Maximal current	RW	0x1388 (5000)	
8020:02	Nominal current	RW	0x0DAC (3500)	
8020:03	Nominal voltage	RW	0xC350 (50000)	
8020:04	Motor coil resistance	RW	0x0064 (100)	
8020:05	Reduced current (positive)	RW	0x07D0 (2000)	
8020:06	Reduced current (negative)	RW	0x07D0 (2000)	
8020:07	Encoder increments (4fold)	RW	0x0000 (0)	
8020:08	Maximal motor velocity	RW	0x0000 (0)	
8020:0C	Time for switch-off at overload	RW	0x00C8 (200)	
8020:0D	Time for current lowering at overload	RW	0x07D0 (2000)	
8020:0E	Torque auto-reduction threshold (posit...	RW	0x00 (0)	
8020:0F	Torque auto-reduction threshold (neg...	RW	0x00 (0)	
8021:0	DCM Controller Settings Ch.1	RW	> 18 <	
8022:0	DCM Features Ch.1	RW	> 54 <	
8023:0	DCM Controller Settings 2 Ch.1	RW	> 8 <	
8030:0	DCM Motor Settings Ch.2	RW	> 15 <	

Fig. 7: Adaptation of the maximal velocity

5.3.4 Selection of the operating mode

You can select the operating mode in the index 0x8022:01 "Operation mode". It is recommended that you select the operation mode "Automatic" (Fig. *Setting the operation mode*) and then set the suitable operation mode for your application on the Process Data tab. Further information on this can be found in the chapter "Process Data".

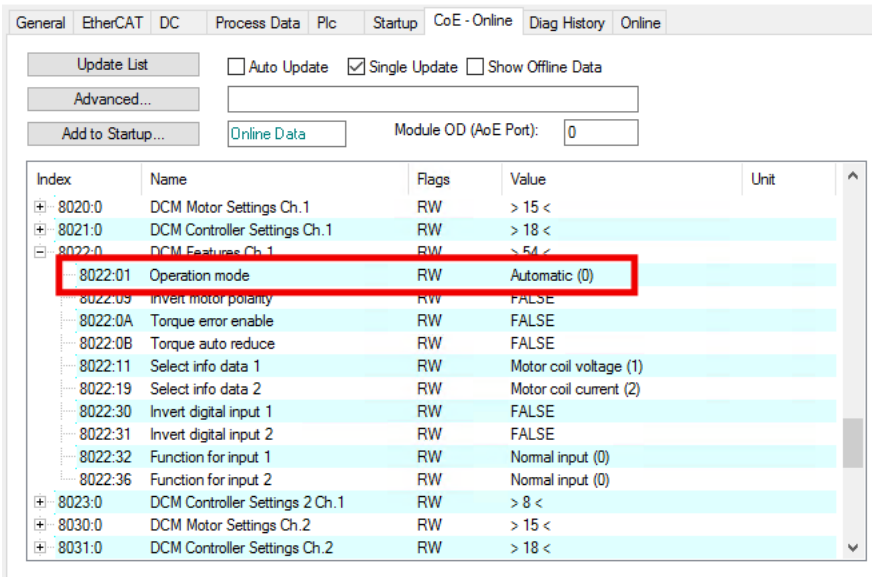

Fig. 8: Setting the operation mode

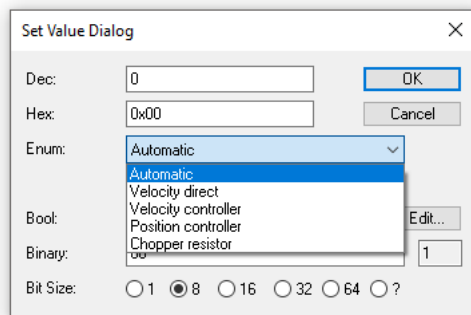

Fig. 9: Dialog box

5.3.5 Select info data

There is a possibility in the index 0x8022:11 "Select info data 1" and 0x8022:19 "Select info data 2", to select two parameters that can be displayed in the process data (see fig. *Selection of additional information data*).

These two parameters must be activated in the process data afterwards.

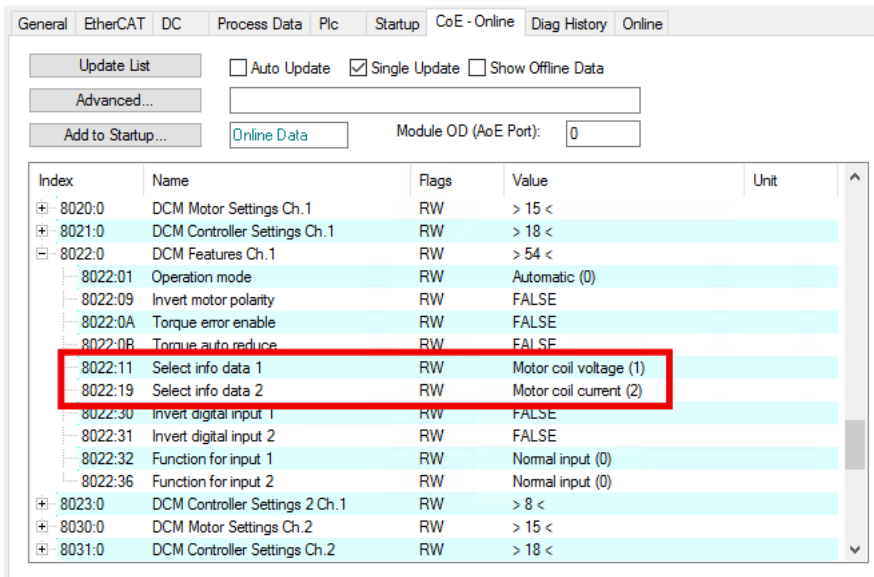

Fig. 10: Selection of additional information data

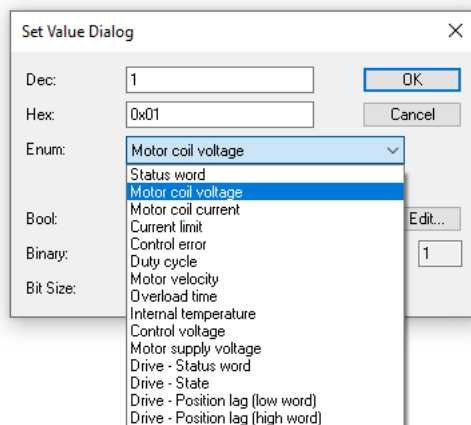

Fig. 11: Dialog box

5.3.6 KA factor

The K_A factor can be used to adapt the current during the acceleration phases. The current increase is calculated as follows.

$$\text{Current increase in mA} = \text{velocity difference} \times K_A / 1000$$

The steeper the velocity ramp, the higher the current increase.

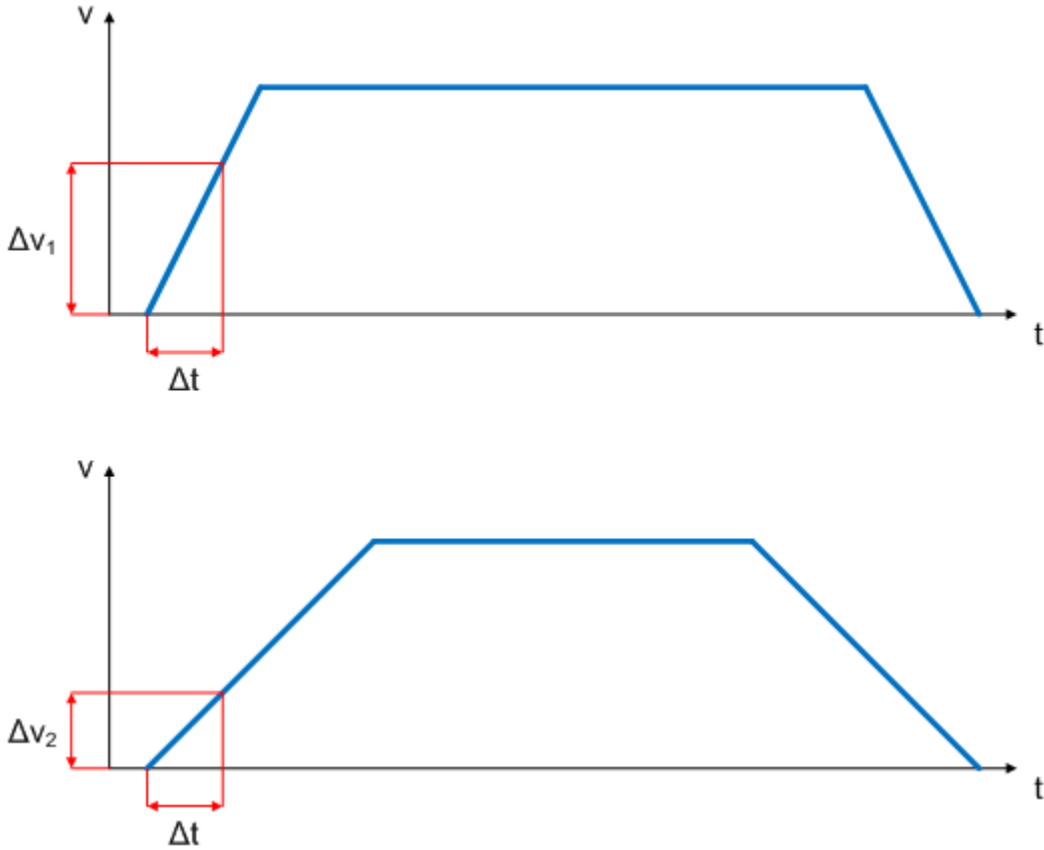

Fig. 12: Velocity ramps

This value can be set in index 0x8023:07 "Ka factor (velo./pos.)" (see Fig. *Setting the KA factor*).

The screenshot shows the 'Index' table in the Beckhoff configuration software. The table has columns for Index, Name, Flags, Value, and Unit. The row for index 8023:07 is highlighted with a red box. The value for this index is 0x0000 (0).

Index	Name	Flags	Value	Unit
8021:0	DCM Controller Settings Ch.1	RW	> 18 <	
8022:0	DCM Features Ch.1	RW	> 54 <	
8023:0	DCM Controller Settings 2 Ch.1	RW	> 8 <	
8023:01	Kp factor (velo./pos.)	RW	0x00C8 (200)	
8023:02	Ki factor (velo./pos.)	RW	0x0002 (2)	
8023:03	Inner window (velo./pos.)	RW	0x00 (0)	
8023:05	Outer window (velo./pos.)	RW	0x00 (0)	
8023:06	Filter cut off frequency (velo./pos.)	RW	0x0000 (0)	
8023:07	Ka factor (velo./pos.)	RW	0x0000 (0)	
8023:08	Kd factor (velo./pos.)	RW	0x0014 (20)	
8030:0	DCM Motor Settings Ch.2	RW	> 15 <	
8031:0	DCM Controller Settings Ch.2	RW	> 18 <	
8032:0	DCM Features Ch.2	RW	> 54 <	
8033:0	DCM Controller Settings 2 Ch.2	RW	> 8 <	
8040:0	POS Settings Ch.1	RW	> 17 <	

Fig. 13: Setting the K_A factor

5.4 NC settings

The specified data apply to a DC Motor GR42X25 of the Company "Dunker Motoren" and are intended as an example. For other motors the values may vary, depending on the application.

5.4.1 Reference velocity selection

The maximum velocity is calculated based on the maximum motor speed (see name plate) and the distance to be covered. In this case the basis is one revolution per second.

$$\begin{aligned}
 v_{\max} &= (\text{maximum motor velocity} \times 360^\circ) / 60\text{s} \\
 &= ((3600 \text{ rpm}) \times 360^\circ) / 60\text{s} \\
 &= 21600 \text{ revolutions / s}
 \end{aligned}$$

This is a theoretical value that is quite close to the practical value, although the value may vary, depending on the load. To determine the actual value set the K_v factor to 0 and determine the final reference velocity empirically. To this end move the motor using the keys F1 - F4 and compare the *actual velocity* and the *setpoint velocity*. These values should be almost identical. If the *actual velocity* is greater, increase the reference velocity slightly. If the *Actual velocity* is smaller than the *Setpoint velocity*, reduce the reference velocity slightly. This empirical exercise should only be carried out once the other parameters have been set. In our case the reference velocity is 25570 revolutions / s. Finally, adjust the *maximum allowed velocity*.

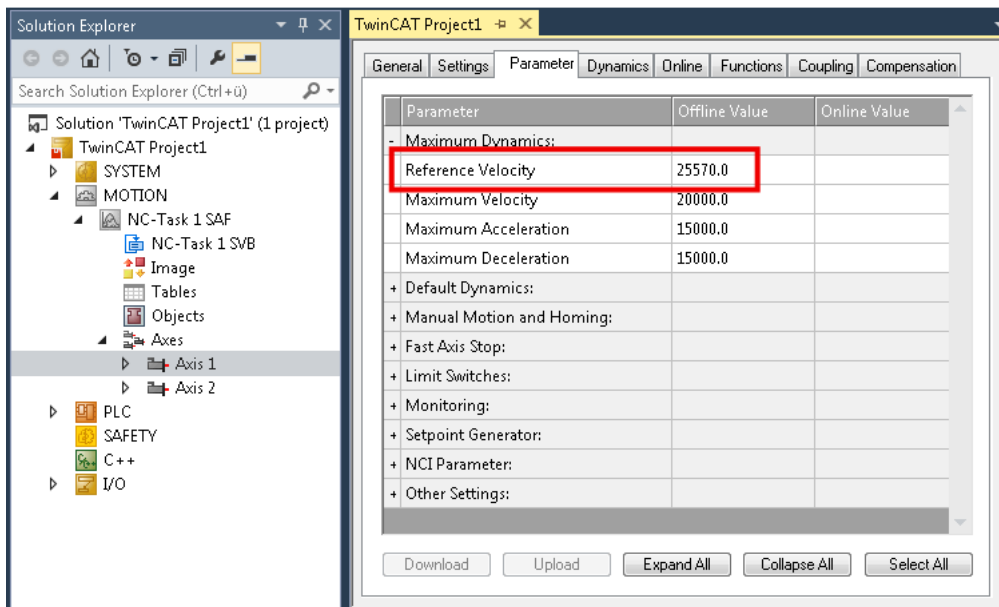

Fig. 14: Reference velocity selection

5.4.2 Dead time compensation

Dead time compensation

The dead time compensation of the axis can be set in the *Time Compensation* tab of the *Axis1_ENC* encoder settings. It should, in theory, be 3 cycles of the NC cycle time, although in practice 4 cycles were found to be preferable. The parameter *Time Compensation Mode Encoder* should be set to 'ON (with velocity)', the parameter *Encoder Delay in Cycles* to 4.

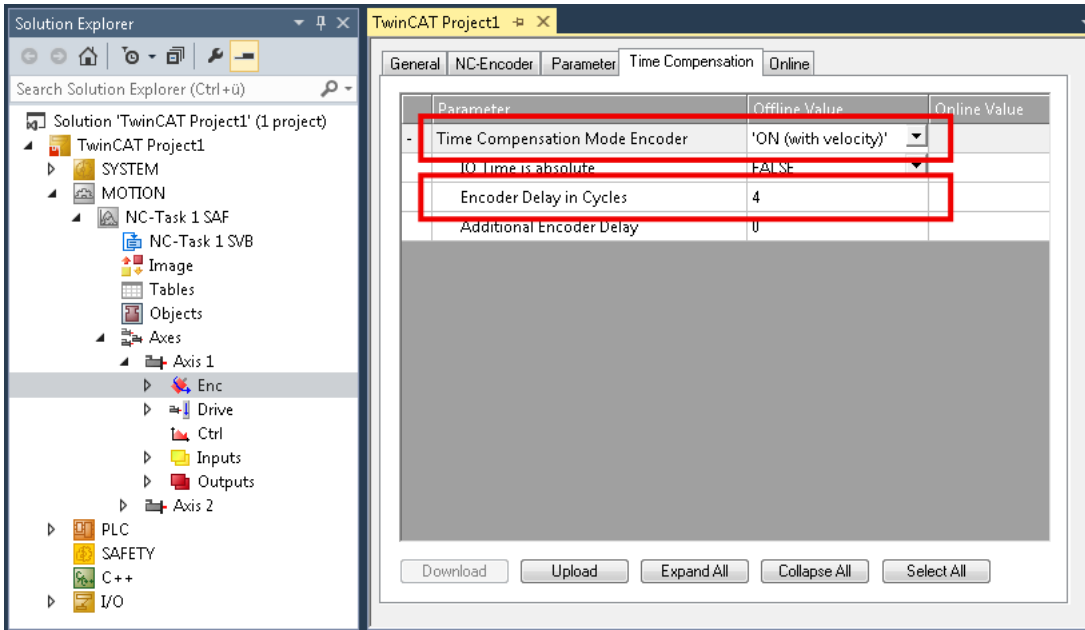

Fig. 15: Dead time compensation parameter

5.4.3 Scaling factor

The scaling factor can be changed by selecting "Axis 1_Enc" and tab "Parameter" in the NC (see fig. *Setting the Scaling Factor*). The value can be calculated with the formulas specified below.

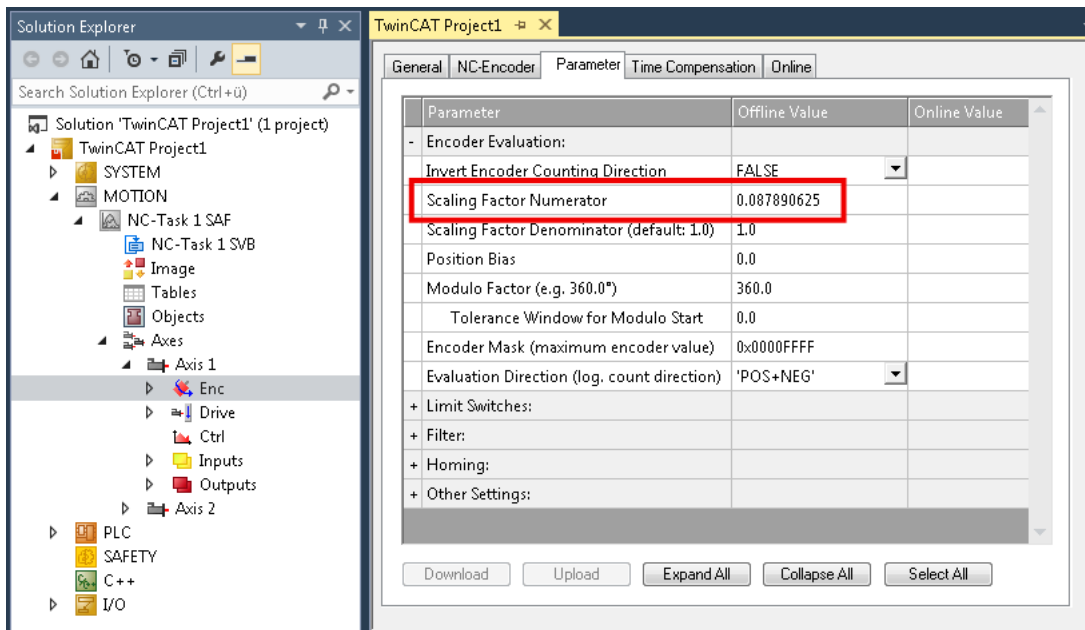

Fig. 16: Setting the Scaling Factor

Calculation of the scaling factor

$$SF = \text{distance per revolution} / (\text{increments} \times 4) = 360^\circ / (1024 \times 4) = 0.087890625^\circ / \text{INC}$$

5.4.4 Position lag monitoring

The position lag monitoring function checks whether the current position lag of an axis has exceeded the limit value. The position lag is the difference between the setpoint (control value) and the actual value reported back. Suboptimal parameter settings can lead to an error in position lag monitoring during the axis movement. During commissioning it may therefore be advisable to increase the "Maximum Position Lag Value" slightly.

NOTICE

CAUTION: Damage to equipment, machines and peripheral components possible!

Setting the position lag monitoring parameters too high may result in damage to equipment, machines and peripheral components.

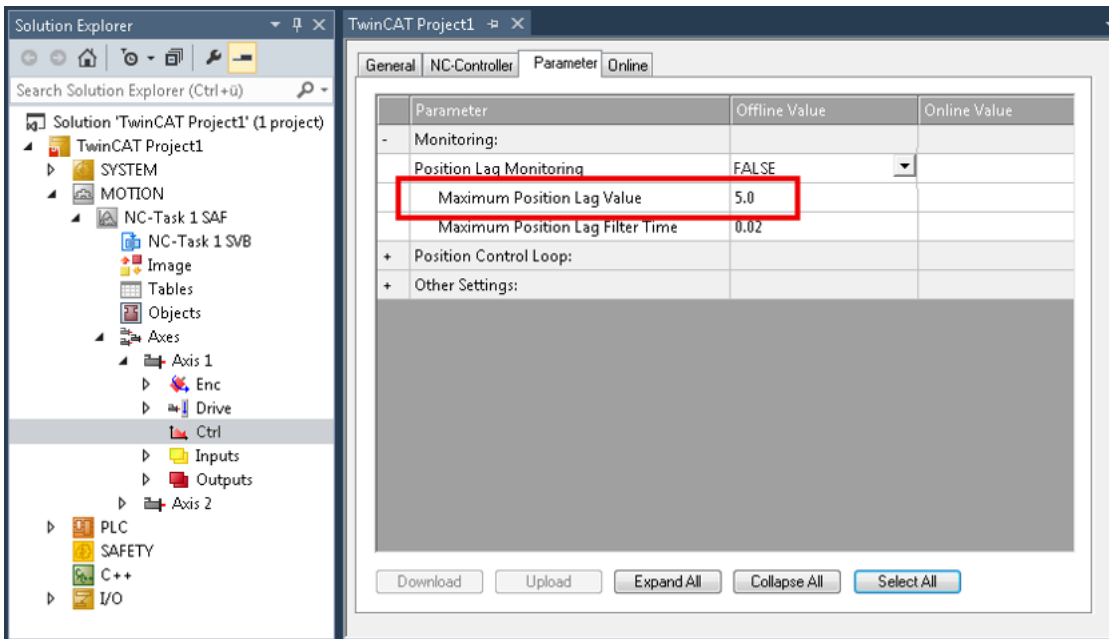

Fig. 17: Position lag monitoring

5.4.5 KV factors

In the NC two proportional factors K_v can be set under "Axis 1_Ctrl " in tab "Parameter". First select the position controller *Type* with two P constants (with K_A) under the "NC Controller" tab. The two P constants are for the *Standstill* range and for the *Moving* range (see Fig. *Setting the proportional factor KV*). The factors can be used to set the start-up torque and the braking torque to a different value than the drive torque. The threshold value can be set directly below (Position control: Velocity threshold V_{dyn}) between 0.0 (0%) and 1.0 (100%). Fig. *Velocity ramp with KV factor limit values* shows a speed ramp with thresholds of 50%. The K_v factor for Standstill (t_1 and t_3) can be different than the K_v factor for Moving (t_2). The factor at standstill should always be greater than the factor during motion.

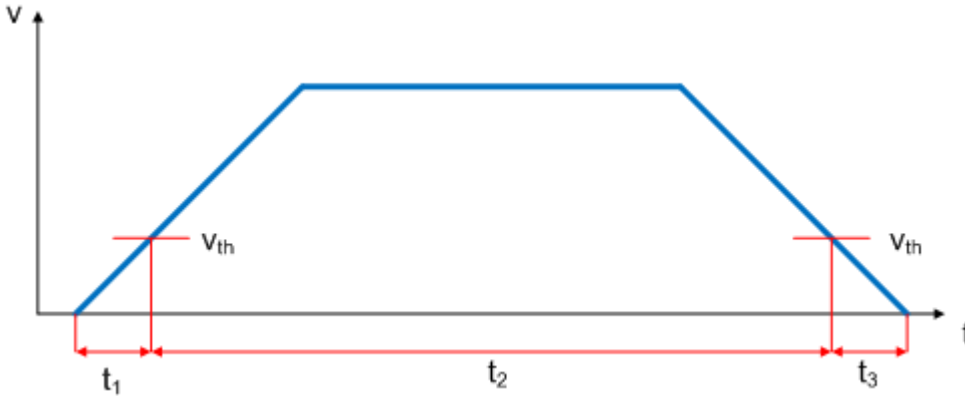

Fig. 18: Velocity ramp with K_v factor limit values

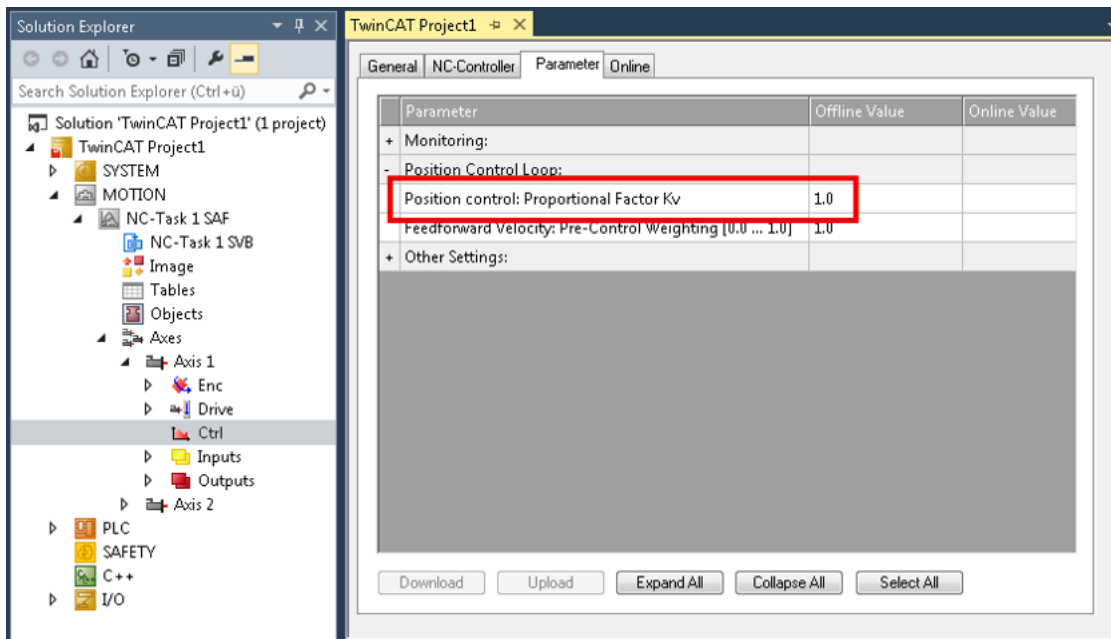

Fig. 19: Setting the proportional factor K_v

5.5 Commissioning the motor with the NC

Enabling an axis

- Once the parameters are set, the motor is basically ready for operation. Individual further parameters have to be adapted to the respective application.
- To commission the axis, activate the configuration (Ctrl+Shift+F4), select the axis, select tab Online and enable the axis under Set.
- Set all tick marks and set Override to 100% (see Fig. *Enabling an axis*). The axis can then be moved.

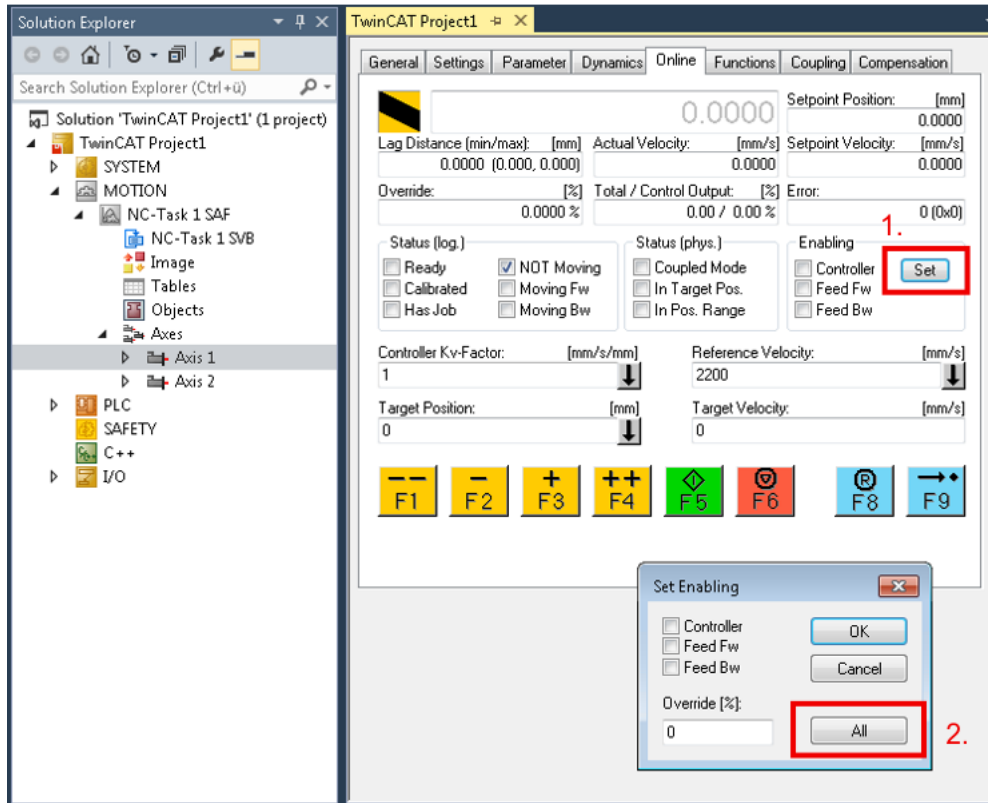

Fig. 20: Enabling an axis

Move axis manually

You can now move the axis with the function keys F1, F2 (Backward) or F3, F4 (Forward). You can adjust the Kv factor in order to approach a suitable factor. Set the value to 0 initially in order to set the correct reference velocity. For calculating the reference velocity please refer to section "Selecting the reference velocity". The calculation provides a relatively precise value, although the value may have to be corrected slightly. To this end move the motor with a Kv factor of 0 until the actual velocity matches the setpoint velocity.

Move axis automatically

Alternatively you can control the axis via the "Functions" tab. An example is provided below.

- Select *Reversing Sequence* as the start type.
- Enter the required *Target Position1*, e.g. 5000°.
- Enter the required Target Velocity, e.g. 2000°/s.
- Enter the required Target Position2, e.g. 0°.
- Enter the required *Idle Time*, e.g. 1 s.
- Select Start.

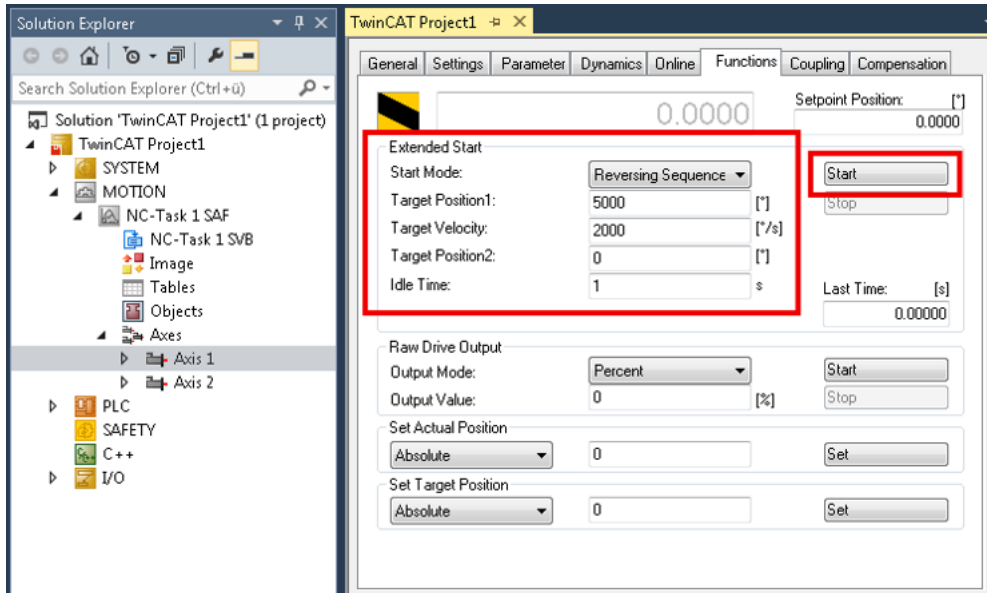

The motor now turns to position 1, remains there for 1 s and returns to position 2. This is repeated until "Stop" is pressed.

5.6 Operating modes

5.6.1 Overview

The operating modes *Automatic*, *Velocity direct*, *Position controller*, *Path control* and *Brake resistor* are supported.

Automatic

In preparation!

Velocity, direct

This mode is intended for the cyclic velocity interface of a numeric controller (NC). In this mode, the NC specifies a set velocity. Ramps for start-up and deceleration of the motor are also controlled by the NC.

Position controller

Refer to the [Positioning Interface \[► 42\]](#) section for information about this operation mode!

Travel distance control

In preparation!

Brake resistor

Refer to the [Chopper operation \[► 40\]](#) section for information about this operation mode

5.6.2 Chopper operation

You can connect a braking resistor (chopper) to one of the two motor channels instead of a DC motor. Select the "Chopper resistor" mode for this channel. See chapter [Selection of the operating mode](#) [► 29].

The motor must actively brake for positioning tasks. The mechanical energy is thereby converted back into electrical energy. Small quantities of energy are taken up by a capacitor in the box. Further storage capacities, for example in the power supply unit, can also take up energy. In any case, the feedback leads to an increase in voltage.

A braking resistor converts the excess energy into heat. When the voltage reaches 110% of the nominal voltage (see chapter [Adaptation of current and voltage](#) [► 26]), the correctly set output stage sends a fast-pulsed current through the braking resistor.

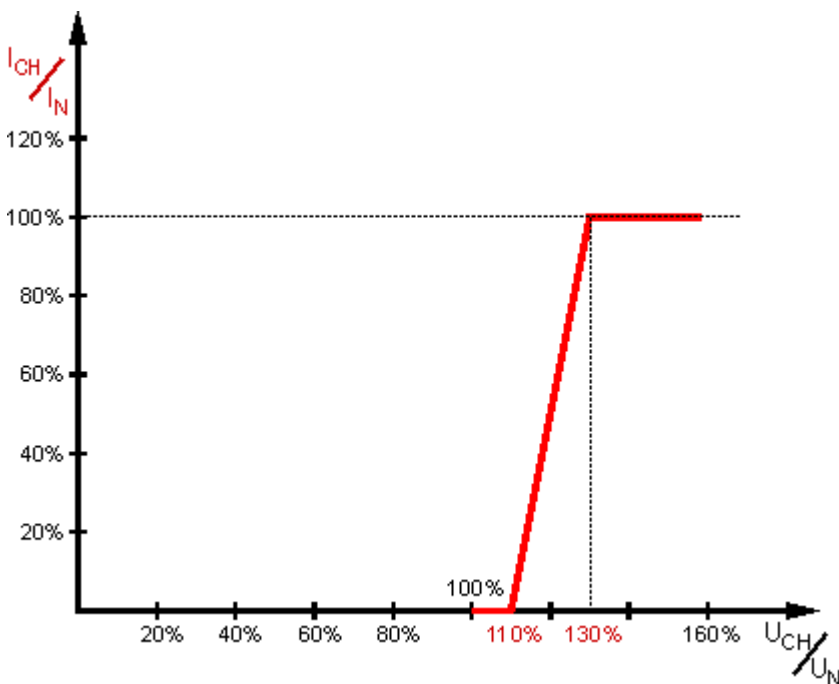

Example: Nominal voltage 48 V

20%	40%	60%	80%	100%	110%	130%	160%
9.6 V	19.2 V	28.8 V	38.4 V	48 V	52.8 V	57.6 V	76.8 V

Example: Nominal voltage 24 V

20%	40%	60%	80%	100%	110%	130%	160%
4.8 V	9.6 V	14.4 V	19.2 V	24 V	25.2 V	31.2 V	38.4 V

5.6.2.1 Dimensioning of the braking resistor

NOTICE

Braking resistor overload

If the braking resistor is insufficiently dimensioned, it can be destroyed by overload.

- The braking resistor should be dimensioned such that it can withstand the expected heat development without damage.

A braking resistor of 10 Ω is recommended. This results in a pulse current of approx. 5.28 A to 5.76 A. The maximum expected continuous power is 125 W. However, the value typically lies significantly below that.

Power estimation

$$P_N = I_N^2 \times R$$

$$P_N = (5 \text{ A})^2 \times 10 \Omega$$

$$P_N = 250 \text{ W}$$

A maximum duty cycle of 50 % is possible. This results in a maximum continuous power of 125 W.

A motor efficiency of 80% is usual in practice.

The motor thus converts 80% of the nominal electrical power into kinetic energy when accelerating.

Conversely, when braking, the motor (as a generator) converts 80% of the kinetic energy into electrical power.

This results in a practical braking power of:

$$P_{\text{Chopper}} = P_N / 2 \times 80/100 \times 80/100$$

$$P_{\text{Chopper}} = 125 \text{ W} \times 80/100 \times 80/100$$

$$P_{\text{Chopper}} = 80 \text{ W}$$

5.6.3 Positioning Interface

The "Positioning Interface" offers the option to execute motion commands directly on the box.

NOTICE



Commissioning

Commissioning of the EL7342 "Positioning Interface" can be transferred to EPP7342-0002. The commissioning procedure is described in the chapter on "Basic principles for the Positioning Interface" of the [EL7342 documentation](#).

5.7 Restore the delivery state

You can restore the delivery state of the backup objects as follows:

1. Ensure that TwinCAT is running in Config mode.
2. In CoE object 1011:0 "Restore default parameters" select parameter 1011:01 "Subindex 001".

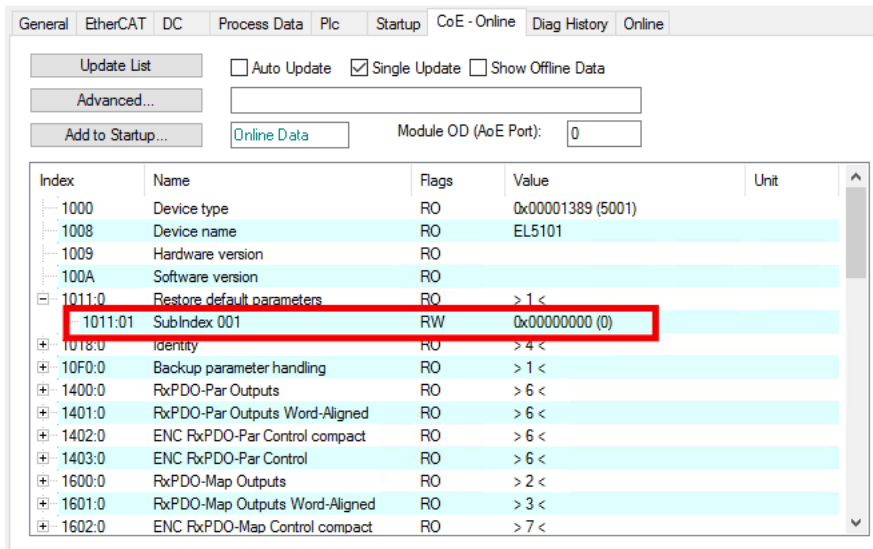

3. Double-click on "Subindex 001".
⇒ The "Set Value Dialog" dialog box opens.
4. Enter the value 1684107116 in the "Dec" field.
Alternatively: enter the value 0x64616F6C in the "Hex" field.

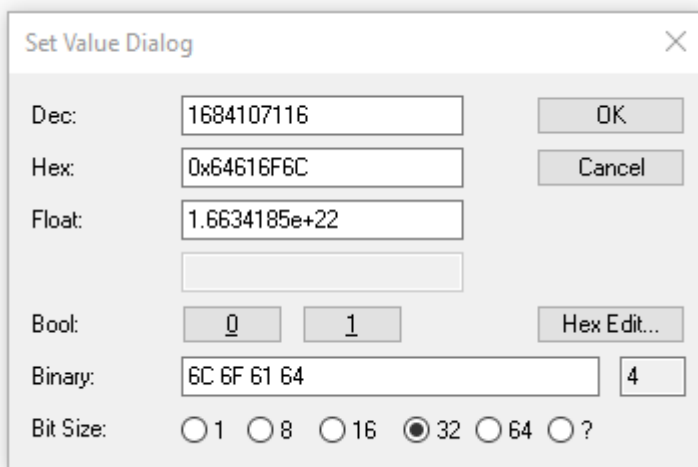

5. Confirm with "OK".
⇒ All backup objects are reset to the delivery state.

i Alternative restore value

With some older modules the backup objects can be changed with an alternative restore value:

Decimal value: 1819238756

Hexadecimal value: 0x6C6F6164

An incorrect entry for the restore value has no effect.

5.8 Decommissioning

⚠ WARNING**Risk of electric shock!**

Bring the bus system into a safe, de-energized state before starting disassembly of the devices!

6 CoE parameters

● EtherCAT XML Device Description

i The display matches that of the CoE objects from the EtherCAT XML Device Description. We recommend downloading the latest XML file from the download area of the Beckhoff website and installing it according to installation instructions.

● Parameterization via the CoE list (CAN over EtherCAT)

i The EtherCAT device is parameterized via the CoE-Online tab (double-click on the respective object) or via the Process Data tab (allocation of PDOs). Please note the following general CoE notes when using/manipulating the CoE parameters:

- Keep a startup list if components have to be replaced
- Differentiation between online/offline dictionary, existence of current XML description
- use “CoE reload” for resetting changes

Introduction

The CoE overview contains objects for different intended applications:

- Objects required for parameterization during commissioning:
 - [Restore object \[► 45\]](#)
 - Configuration data
 - Command object
- Profile-specific objects:
 - Input data
 - Output data
 - Information and diagnosis data (channel specific)
 - Configuration data (vendor-specific)
 - Information and diagnosis data (device-specific)
- Standard objects

The following section first describes the objects required for normal operation, followed by a complete overview of missing objects.

6.1 Restore object

Index 1011 Restore default parameters

Index (hex)	Name	Meaning	Data type	Flags	Default
1011:0	Restore default parameters	Restore default parameters	UINT8	RO	0x01 (1 _{dec})
1011:01	SubIndex 001	If this object is set to “0x64616F6C” in the set value dialog, all backup objects are reset to their delivery state.	UINT32	RW	0x00000000 (0 _{dec})

6.2 Configuration data

Index 8000 ENC Settings Ch.1

Index (hex)	Name	Meaning	Data type	Flags	Default
8000:0	ENC Settings Ch.1	Max. Subindex	UINT8	RO	0x0E (14 _{dec})
8000:08	Disable filter	0: Activates the input filter (inputs A, /A, B, /B, C, /C only) 1: Deactivates the input filter If a filter is activated a signal edge must be present for at least 2.4 µs in order to be counted as an increment.	BOOLEAN	RW	0x00 (0 _{dec})
8000:0A	Enable micro increments	If activated, the terminal interpolates micro-increments between the integral encoder increments in DC mode. The lower 8 bits of the counter value are used in each case for the display. A 32-bit counter thus becomes a 24 +8 bit counter, a 16-bit counter becomes a 8 +8 bit counter.	BOOLEAN	RW	0x00 (0 _{dec})
8000:0E	Reversion of rotation	Activates reversion of rotation	BOOLEAN	RW	0x00 (0 _{dec})

Index 8010 ENC Settings Ch.2

Index (hex)	Name	Meaning	Data type	Flags	Default
8010:0	ENC Settings Ch.2	Max. Subindex	UINT8	RO	0x0E (14 _{dec})
8010:08	Disable filter	0: Activates the input filter (inputs A, /A, B, /B, C, /C only) 1: Deactivates the input filter If a filter is activated a signal edge must be present for at least 2.4 µs in order to be counted as an increment.	BOOLEAN	RW	0x00 (0 _{dec})
8010:0A	Enable micro increments	If activated, the terminal interpolates micro-increments between the integral encoder increments in DC mode. The lower 8 bits of the counter value are used in each case for the display. A 32-bit counter thus becomes a 24 +8 bit counter, a 16-bit counter becomes a 8 +8 bit counter.	BOOLEAN	RW	0x00 (0 _{dec})
8010:0E	Reversion of rotation	Activates reversion of rotation	BOOLEAN	RW	0x00 (0 _{dec})

Index 8020 DCM Motor Settings Ch.1

Index (hex)	Name	Meaning	Data type	Flags	Default
8020:0	DCM Motor Settings Ch.1	Max. Subindex	UINT8	RO	0x0F (15 _{dec})
8020:01	Maximal current	Maximum permanent motor coil current (Unit: 1 mA) Notice Risk of material damage. Set this parameter to a maximum of 5000 (decimal).	UINT16	RW	0x1388 (5000 _{dec})
8020:02	Nominal current	Nominal current of the motor (Unit: 1 mA) Notice Risk of material damage. Set this parameter to a maximum of 3500 (decimal).	UINT16	RW	0x0DAC (3500 _{dec})
8020:03	Nominal voltage	Nominal voltage (supply voltage) of the motor (Unit: 1 mV)	UINT16	RW	0xC350 (50000 _{dec})
8020:04	Motor coil resistance	Internal resistance of the motor (Unit: 0.01 ohm)	UINT16	RW	0x0064 (100 _{dec})
8020:05	Reduced current (positive)	Reduced torque in positive direction of rotation (Unit: 1 mA)	UINT16	RW	0x07D0 (2000 _{dec})
8020:06	Reduced current (negative)	Reduced torque in negative direction of rotation (Unit: 1 mA)	UINT16	RW	0x07D0 (2000 _{dec})
8020:07	Encoder increments (4-fold)	Number of encoder increments per revolution with 4-fold evaluation	UINT16	RW	0x0000 (0 _{dec})
8020:08	Maximal motor velocity	Nominal speed of the motor at the nominal voltage (Unit: 1 rpm)	UINT16	RW	0x0000 (0 _{dec})
8020:0C	Time for switch-off at overload	Time for switch-off at overload (Unit: 1 ms)	UINT16	RW	0x00C8 (200 _{dec})
8020:0D	Time for current lowering at overload	Time for current lowering at overload (from max. current to nominal current, unit: 1 ms)	UINT16	RW	0x07D0 (2000 _{dec})
8020:0E	Torque auto-reduction threshold (positive)	Process data threshold for torque auto-reduction in the positive direction of rotation (Unit: 1 %)	UINT8	RW	0x00 (0 _{dec})
8020:0F	Torque auto-reduction threshold (negative)	Process data threshold for torque auto-reduction in the negative direction of rotation (Unit: 1 %)	UINT8	RW	0x00 (0 _{dec})

Index 8021 DCM Controller Settings Ch.1

Index (hex)	Name	Meaning	Data type	Flags	Default
8021:0	DCM Controller Settings Ch.1	Max. Subindex	UINT8	RO	0x12 (18 _{dec})
8021:01	Kp factor (curr.)	Kp control factor of the current controller	UINT16	RW	0x00C8 (200 _{dec})
8021:02	Ki factor (curr.)	Ki control factor of the current controller	UINT16	RW	0x0002 (2 _{dec})
8021:03	Inner window (curr.)	Inner window for the I component (unit: 1%)	UINT8	RW	0x00 (0 _{dec})
8021:05	Outer window (curr.)	Outer window for the I component (unit: 1%)	UINT8	RW	0x00 (0 _{dec})
8021:06	Filter cut off frequency (curr.)	Limit frequency of the current controller (unit: 1 Hz)	UINT16	RW	0x0000 (0 _{dec})
8021:11	Voltage adjustment enable	Activates the compensation of voltage fluctuations (only in the operating mode "Direct velocity")	BOOLEAN	RW	0x00 (0 _{dec})
8021:12	Current adjustment enable	Activates the R x I compensation	BOOLEAN	RW	0x00 (0 _{dec})

Index 8022 DCM Features Ch.1

Index (hex)	Name	Meaning	Data type	Flags	Default
8022:0	DCM Features Ch.1	Max. Subindex	UINT8	RO	0x36 (54 _{dec})
8022:01	Operation mode	Operation mode 0: Automatic 1: Velocity direct 2: Velocity controller 3: Position controller ...: reserved 14: Velocity direct with Rxl compensation 15: Chopper resistor Existing overvoltage (10 % > nominal voltage 0x8020:03 [▶ 47]) is reduced via connected chopper resistor.	BIT4	RW	0x00 (0 _{dec})
8022:09	Invert motor polarity	Inverts the direction of rotation of the motor	BOOLEAN	RW	0x00 (0 _{dec})
8022:0A	Torque error enable	Activates the automatic overload cut-off (see also subindex 0x8020:0C [▶ 47])	BOOLEAN	RW	0x00 (0 _{dec})
8022:0B	Torque auto reduce	Activates the automatic torque reduction (see also subindex 0x8020:0D [▶ 47] - 0x8020:0F [▶ 47])	BOOLEAN	RW	0x00 (0 _{dec})
8022:0C	Threshold activation from PDO		BOOLEAN	RW	0x00 (0 _{dec})
8022:11	Select info data 1	Selection "Info data 1" 0: Status word 1: Motor coil voltage 2: Motor coil current 3: Current limit 4: Control error 5: Duty cycle ...: reserved 7: Motor velocity 8: Overload time ...: reserved 101: Internal temperature ...: reserved 103: Control voltage 104: Motor supply voltage ...: reserved 150: Status word (drive controller) 151: State (drive controller) ...: reserved	UINT8	RW	0x01 (1 _{dec})
8022:19	Select info data 2	Selection "Info data 2" see subindex 0x8022:11 [▶ 48]	UINT8	RW	0x02 (2 _{dec})
8022:30	Invert digital input 1	Inversion of digital input 1	BOOLEAN	RW	0x00 (0 _{dec})
8022:31	Invert digital input 2	Inversion of digital input 2	BOOLEAN	RW	0x00 (0 _{dec})
8022:32	Function for input 1	Function of digital input 1 0: Normal input 1: Hardware enable ...: reserved	BIT4	RW	0x00 (0 _{dec})
8022:36	Function for input 2	Function of digital input 2 see subindex 0x8022:32 [▶ 48]	BIT4	RW	0x00 (0 _{dec})

Index 8023 DCM controller settings 2 ch.1

Index (hex)	Name	Meaning	Data type	Flags	Default
8023:0	DCM controller settings 2 ch.1	Max. subindex	UINT8	RO	0x08 (8 _{dec})
8023:01	Kp factor (velo./pos.)	Kp control factor of the velocity/position controller	UINT16	RW	0x00C8 (200 _{dec})
8023:02	Ki factor (velo./pos.)	Ki control factor of the velocity/position controller	UINT16	RW	0x0002 (2 _{dec})
8023:03	Inner window (velo./pos.)	Inner window for the I component (unit: 1%)	UINT8	RW	0x00 (0 _{dec})
8023:05	Outer window (velo./pos.)	Outer window for the I component (unit: 1%)	UINT8	RW	0x00 (0 _{dec})
8023:06	Filter cut off frequency (velo./pos.)	Limit frequency of the velocity/position controller (unit: 1 Hz)	UINT16	RW	0x0000 (0 _{dec})
8023:07	Ka factor (velo./pos.)	Ka control factor of the velocity/position controller	UINT16	RW	0x0000 (0 _{dec})
8023:08	Kd factor (velo./pos.)	Kd control factor of the velocity/position controller	UINT16	RW	0x0014 (20 _{dec})
8023:09	Kp factor 1 (pos.)	tbd	UINT16	RW	0x0000 (0 _{dec})
8023:0A	Kp factor 2 (pos.)	tbd	UINT16	RW	0x0000 (0 _{dec})
8023:0B*	Threshold Kp 1 (pos.)	tbd	UINT8	RW	0x00 (0 _{dec})
8023:0D	Threshold Kp 2 (pos.)	tbd	UINT8	RW	0x00 (0 _{dec})
8023:10	Controller version (velo./pos.)	This parameter has no function. Leave the parameter in the factory setting.	UINT8	RW	0x00 (0 _{dec})
8023:12	Kp factor (Rxl compensation)	Fine adjustment of the Rxl compensation. Unit: 1/1000	UINT16	RW	0x03E8 (1000 _{dec})

Index 8030 DCM Motor Settings Ch.2

Index (hex)	Name	Meaning	Data type	Flags	Default
8030:0	DCM Motor Settings Ch.2	Max. Subindex	UINT8	RO	0x0F (15 _{dec})
8030:01	Maximal current	Maximum permanent motor coil current (unit: 1 mA)	UINT16	RW	0x1388 (5000 _{dec})
8030:02	Nominal current	Motor nominal current (unit: 1 mA)	UINT16	RW	0x0DAC (3500 _{dec})
8030:03	Nominal voltage	Nominal voltage (supply voltage) of the motor (unit: 1 mV)	UINT16	RW	0xC350 (50000 _{dec})
8030:04	Motor coil resistance	Internal resistance of the motor (unit: 0.01 ohm)	UINT16	RW	0x0064 (100 _{dec})
8030:05	Reduced current (positive)	Reduced torque in positive direction of rotation (unit: 1 mA)	UINT16	RW	0x07D0 (2000 _{dec})
8030:06	Reduced current (negative)	Reduced torque in negative direction of rotation (unit: 1 mA)	UINT16	RW	0x07D0 (2000 _{dec})
8030:07	Encoder increments (4-fold)	Number of encoder increments per revolution with quadruple evaluation	UINT16	RW	0x0000 (0 _{dec})
8030:08	Maximal motor velocity	Rated motor velocity at nominal voltage (unit: 1 rpm)	UINT16	RW	0x0000 (0 _{dec})
8030:0C	Time for switch-off at overload	Time for switch-off at overload (unit: 1 ms)	UINT16	RW	0x00C8 (200 _{dec})
8030:0D	Time for current lowering at overload	Time for current lowering at overload (from max. current to nominal current, unit: 1 ms)	UINT16	RW	0x07D0 (2000 _{dec})
8030:0E	Torque auto-reduction threshold (positive)	Process data threshold for automatic torque reduction in the positive direction of rotation (unit: 1 %)	UINT8	RW	0x00 (0 _{dec})
8030:0F	Torque auto-reduction threshold (negative)	Process data threshold for automatic torque reduction in the negative direction of rotation (unit: 1 %)	UINT8	RW	0x00 (0 _{dec})

Index 8031 DCM Controller Settings Ch.2

Index (hex)	Name	Meaning	Data type	Flags	Default
8031:0	DCM Controller Settings Ch.2	Max. Subindex	UINT8	RO	0x12 (18 _{dec})
8031:01	Kp factor (curr.)	Kp control factor of the current controller	UINT16	RW	0x00C8 (200 _{dec})
8031:02	Ki factor (curr.)	Ki control factor of the current controller	UINT16	RW	0x0002 (2 _{dec})
8031:03	Inner window (curr.)	Inner window for the I component (unit: 1%)	UINT8	RW	0x00 (0 _{dec})
8031:05	Outer window (curr.)	Outer window for the I component (unit: 1%)	UINT8	RW	0x00 (0 _{dec})
8031:06	Filter cut off frequency (curr.)	Limit frequency of the current controller (unit: 1 Hz)	UINT16	RW	0x0000 (0 _{dec})
8031:11	Voltage adjustment enable	Activates the compensation of voltage fluctuations (only in the operating mode "Direct velocity")	BOOLEAN	RW	0x00 (0 _{dec})
8031:12	Current adjustment enable	Activates the R x I compensation	BOOLEAN	RW	0x00 (0 _{dec})

Index 8032 DCM Features Ch.2

Index (hex)	Name	Meaning	Data type	Flags	Default
8032:0	DCM Features Ch.2	Max. Subindex	UINT8	RO	0x36 (54 _{dec})
8032:01	Operation mode	Operation mode 0: Automatic 1: Velocity direct 2: Velocity controller 3: Position controller ...: reserved 15: Chopper resistor Existing overvoltage (10% > nominal voltage 0x8030:03 [▶ 49]) is reduced via connected chopper resistor.	BIT4	RW	0x00 (0 _{dec})
8032:09	Invert motor polarity	Inverts the direction of rotation of the motor	BOOLEAN	RW	0x00 (0 _{dec})
8032:0A	Torque error enable	Activates the automatic overload cut-off (see also subindex 0x8030:0C [▶ 49])	BOOLEAN	RW	0x00 (0 _{dec})
8032:0B	Torque auto reduce	Activates the automatic torque reduction (see also subindex 0x8030:0D [▶ 49] – 0x8030:0F [▶ 49])	BOOLEAN	RW	0x00 (0 _{dec})
8032:0C	Threshold activation from PDO		BOOLEAN	RW	0x00 (0 _{dec})
8032:11	Select info data 1	Selection "Info data 1" 0: Status word 1: Motor coil voltage 2: Motor coil current 3: Current limit 4: Control error 5: Duty cycle ...: reserved 7: Motor velocity 8: Overload time ...: reserved 101: Internal temperature ...: reserved 103: Control voltage 104: Motor supply voltage ...: reserved 150: Status word (drive controller) 151: State (drive controller) ...: reserved	UINT8	RW	0x01 (1 _{dec})
8032:19	Select info data 2	Selection "Info data 2" see subindex 0x8032:11 [▶ 51]	UINT8	RW	0x02 (2 _{dec})
8032:30	Invert digital input 1	Inversion of digital input 1	BOOLEAN	RW	0x00 (0 _{dec})
8032:31	Invert digital input 2	Inversion of digital input 2	BOOLEAN	RW	0x00 (0 _{dec})
8032:32	Function for input 1	Function of digital input 1 0: Normal input 1: Hardware enable ...: reserved	BIT4	RW	0x00 (0 _{dec})
8032:36	Function for input 2	Function of digital input 2 see subindex 0x8032:32 [▶ 51]	BIT4	RW	0x00 (0 _{dec})

Index 8033 DCM controller settings 2 ch.2

Index (hex)	Name	Meaning	Data type	Flags	Default
8033:0	DCM controller settings 2 ch.2	Max. subindex	UINT8	RO	0x08 (8 _{dec})
8033:01	Kp factor (velo./pos.)	Kp control factor of the velocity/position controller	UINT16	RW	0x00C8 (200 _{dec})
8033:02	Ki factor (velo./pos.)	Ki control factor of the velocity/position controller	UINT16	RW	0x0002 (2 _{dec})
8033:03	Inner window (velo./pos.)	Inner window for the I component (unit: 1%)	UINT8	RW	0x00 (0 _{dec})
8033:05	Outer window (velo./pos.)	Outer window for the I component (unit: 1%)	UINT8	RW	0x00 (0 _{dec})
8033:06	Filter cut off frequency (velo./pos.)	Limit frequency of the velocity/position controller (unit: 1 Hz)	UINT16	RW	0x0000 (0 _{dec})
8033:07	Ka factor (velo./pos.)	Ka control factor of the velocity/position controller	UINT16	RW	0x0000 (0 _{dec})
8033:08	Kd factor (velo./pos.)	Kd control factor of the velocity/position controller	UINT16	RW	0x0014 (20 _{dec})
8033:09	Kp factor 1 (pos.)	tbd	UINT16	RW	0x0000 (0 _{dec})
8033:0A	Kp factor 2 (pos.)	tbd	UINT16	RW	0x0000 (0 _{dec})
8033:0B*	Threshold Kp 1 (pos.)	tbd	UINT8	RW	0x00 (0 _{dec})
8033:0D	Threshold Kp 2 (pos.)	tbd	UINT8	RW	0x00 (0 _{dec})
8033:10	Controller version (velo./pos.)	This parameter has no function. Leave the parameter in the factory setting.	UINT8	RW	0x00 (0 _{dec})
8033:12	Kp factor (Rxl compensation)	Fine adjustment of the Rxl compensation. Unit: 1/1000	UINT16	RW	0x03E8 (1000 _{dec})

Index 8040 POS Settings Ch.1

Index (hex)	Name	Meaning	Data type	Flags	Default
8040:0	POS Settings Ch.1	Max. Subindex	UINT8	RO	0x10 (16 _{dec})
8040:01	Velocity min.	Minimum set velocity (range: 0-10000)	INT16	RW	0x0064 (100 _{dec})
8040:02	Velocity max.	Maximum set velocity (range: 0-10000)	INT16	RW	0x2710 (10000 _{dec})
8040:03	Acceleration pos.	Acceleration time in positive direction of rotation (unit: 1 ms)	UINT16	RW	0x03E8 (1000 _{dec})
8040:04	Acceleration neg.	Acceleration time in negative direction of rotation (unit: 1 ms)	UINT16	RW	0x03E8 (1000 _{dec})
8040:05	Deceleration pos.	Deceleration time in positive direction of rotation (unit: 1 ms)	UINT16	RW	0x03E8 (1000 _{dec})
8040:06	Deceleration neg.	Deceleration time in negative direction of rotation (unit: 1 ms)	UINT16	RW	0x03E8 (1000 _{dec})
8040:07	Emergency deceleration	Emergency deceleration time (both directions of rotation, unit: 1 ms)	UINT16	RW	0x0064 (100 _{dec})
8040:08	Calibration position	Calibration position	UINT32	RW	0x00000000 (0 _{dec})
8040:09	Calibration velocity (towards plc cam)	Calibration velocity towards the cam (range: 0-10000)	INT16	RW	0x03E8 (1000 _{dec})
8040:0A	Calibration Velocity (off plc cam)	Calibration velocity away from the cam (range: 0-10000)	INT16	RW	0x0064 (100 _{dec})
8040:0B	Target window	Target window	UINT16	RW	0x000A (10 _{dec})
8040:0C	In-Target timeout	Timeout at target position (unit: 1 ms)	UINT16	RW	0x03E8 (1000 _{dec})
8040:0D	Dead time compensation	Dead time compensation (unit: 1 µs)	INT16	RW	0x0064 (100 _{dec})
8040:0E	Modulo factor	Modulo factor/position	UINT32	RW	0x00000000 (0 _{dec})
8040:0F	Modulo tolerance window	Tolerance window for modulo positioning	UINT32	RW	0x00000000 (0 _{dec})
8040:10	Position lag max.	Max. permitted position lag	UINT16	RW	0x0000 (0 _{dec})

Index 8041 POS Features Ch.1

Index (hex)	Name	Meaning	Data type	Flags	Default
8041:0	POS Features Ch.1		UINT8	RO	0x16 (22 _{dec})
8041:01	Start type	Standard start type	UINT16	RW	0x0001 (1 _{dec})
8041:11	Time information	Time information in subindex 0x6pp0: 22 ("Actual drive time") 0: Elapsed time current drive time since start of the travel command ...: reserved	BIT2	RW	0x00 (0 _{dec})
8041:13	Invert calibration cam search direction	Inversion of the direction of rotation towards the cam	BOOLEAN	RW	0x01 (1 _{dec})
8041:14	Invert sync impulse search direction	Inversion of the direction of rotation away from the cam	BOOLEAN	RW	0x00 (0 _{dec})
8041:15	Emergency stop on position lag error	- Lag error monitoring has triggered - an emergency stop is triggered as soon as "Position lag" = 1. The "Misc Error" is set to 1 and a PDO error is generated.	BOOLEAN	RW	0x00 (0 _{dec})
8041:16	Enhanced diag history	TRUE: Additional messages are output during the travel command (each change of the state machine (index 0x9040:03 [▶ 62]))	BOOLEAN	RW	0x00 (0 _{dec})

Index 8050 POS Settings Ch.2

Index (hex)	Name	Meaning	Data type	Flags	Default
8050:0	POS Settings Ch.2	Max. Subindex	UINT8	RO	0x10 (16 _{dec})
8050:01	Velocity min.	Minimum set velocity (range: 0-10000)	INT16	RW	0x0064 (100 _{dec})
8050:02	Velocity max.	Maximum set velocity (range: 0-10000)	INT16	RW	0x2710 (10000 _{dec})
8050:03	Acceleration pos.	Acceleration time in positive direction of rotation (unit: 1 ms)	UINT16	RW	0x03E8 (1000 _{dec})
8050:04	Acceleration neg.	Acceleration time in negative direction of rotation (unit: 1 ms)	UINT16	RW	0x03E8 (1000 _{dec})
8050:05	Deceleration pos.	Deceleration time in positive direction of rotation (unit: 1 ms)	UINT16	RW	0x03E8 (1000 _{dec})
8050:06	Deceleration neg.	Deceleration time in negative direction of rotation (unit: 1 ms)	UINT16	RW	0x03E8 (1000 _{dec})
8050:07	Emergency Deceleration	Emergency deceleration time (both directions of rotation, unit: 1 ms)	UINT16	RW	0x0064 (100 _{dec})
8050:08	Calibration position	Calibration position	UINT32	RW	0x00000000 (0 _{dec})
8050:09	Calibration velocity (towards plc cam)	Calibration velocity towards the cam (range: 0-10000)	INT16	RW	0x03E8 (1000 _{dec})
8050:0A	Calibration Velocity (off plc cam)	Calibration velocity away from the cam (range: 0-10000)	INT16	RW	0x0064 (100 _{dec})
8050:0B	Target window	Target window	UINT16	RW	0x000A (10 _{dec})
8050:0C	In-Target timeout	Timeout at target position (unit: 1 ms)	UINT16	RW	0x03E8 (1000 _{dec})
8050:0D	Dead time compensation	Dead time compensation (unit: 1 µs)	INT16	RW	0x0064 (100 _{dec})
8050:0E	Modulo factor	Modulo factor/position	UINT32	RW	0x00000000 (0 _{dec})
8050:0F	Modulo tolerance window	Tolerance window for modulo positioning	UINT32	RW	0x00000000 (0 _{dec})
8050:10	Position lag max.	Max. permitted position lag	UINT16	RW	0x0000 (0 _{dec})

Index 8051 POS Features Ch.2

Index (hex)	Name	Meaning	Data type	Flags	Default
8051:0	POS Features Ch.2	Max. Subindex	UINT8	RO	0x16 (22 _{dec})
8051:01	Start type	Standard start type	UINT16	RW	0x0001 (1 _{dec})
8051:11	Time information	Time information in subindex 0x6pp0: 22 ("Actual drive time") 0: Elapsed time current drive time since start of the travel command ...: reserved	BIT2	RW	0x00 (0 _{dec})
8051:13	Invert calibration cam search direction	Inversion of the direction of rotation towards the cam	BOOLEAN	RW	0x01 (1 _{dec})
8051:14	Invert sync impulse search direction	Inversion of the direction of rotation away from the cam	BOOLEAN	RW	0x00 (0 _{dec})
8051:15	Emergency stop on position lag error	<ul style="list-style-type: none"> Lag error monitoring has triggered an emergency stop is triggered as soon as "Position lag" = 1. The "Misc Error" is set to 1 and a PDO error is generated. 	BOOLEAN	RW	0x00 (0 _{dec})
8051:16	Enhanced diag history	TRUE: Additional messages are output during the travel command (each change of the state machine (index 0x9050:03 ▶ 621))	BOOLEAN	RW	0x00 (0 _{dec})

6.3 Command object

Index FB00 DCM Command

Index (hex)	Name	Meaning	Data type	Flags	Default
FB00:0	DCM Command	Max. Subindex	UINT8	RO	0x03 (3 _{dec})
FB00:01	Request	0x1000 Clear diag history Clear the Diag History 0x1100 Get build number: Read out the build number 0x1101 Get build date Read out the build date 0x1102 Get build time Read out the build time 0x8000 Software reset Perform a software reset (hardware is re-initialized with the current CoE configuration; this otherwise happens only during the transition to INIT)	OCTET-STRING[2]	RW	{0}
FB00:02	Status	0: Finished, no error, no response Command terminated without error and without response 1: Finished, no error, response Command terminated without error and with response 2: Finished, error, no response Command terminated with error and without response 3: Finished, error, response Command terminated with error and with response 255: Executing Command is being executed	UINT8	RO	0x00 (0 _{dec})
FB00:03	Response	dependent on the request	OCTET-STRING[4]	RO	{0}

6.4 Input data

Index 6000 ENC Inputs Ch.1

Index (hex)	Name	Meaning	Data type	Flags	Default
6000:0	ENC Inputs Ch.1	Max. Subindex	UINT8	RO	0x16 (22 _{dec})
6000:02	Latch extern valid	The counter value was locked via the external latch. The data with the index 0x6000:12 [▶ 56] correspond to the latched value with the bit set. In order to re-activate the latch input, index 0x7000:02 [▶ 59] or object index 0x7000:04 [▶ 59] must first be cancelled and then set again.	BOOLEAN	RO	0x00 (0 _{dec})
6000:03	Set counter done	The counter was set.	BOOLEAN	RO	0x00 (0 _{dec})
6000:04	Counter underflow	Counter underflow. Overflow/underflow control is inactive in combination with a reset function (C/external).	BOOLEAN	RO	0x00 (0 _{dec})
6000:05	Counter overflow	Counter overflow. Overflow/underflow control is inactive in combination with a reset function (C/external).	BOOLEAN	RO	0x00 (0 _{dec})
6000:08	Extrapolation stall	The extrapolated part of the counter is invalid.	BOOLEAN	RO	0x00 (0 _{dec})
6000:09	Status of input A	Status of input A	BOOLEAN	RO	0x00 (0 _{dec})
6000:0A	Status of input B	Status of input B	BOOLEAN	RO	0x00 (0 _{dec})
6000:0D	Status of extern latch	Status of the extern latch input	BOOLEAN	RO	0x00 (0 _{dec})
6000:0E	Sync error	The Sync error bit is only required for DC mode. It indicates whether a synchronization error has occurred during the previous cycle. This means a SYNC signal was triggered in the terminal, although no new process data were available (0=OK, 1=NOK).	BOOLEAN	RO	0x00 (0 _{dec})
6000:10	TxPDO Toggle	The TxPDO toggle is toggled by the slave when the data of the associated TxPDO is updated.	BOOLEAN	RO	0x00 (0 _{dec})
6000:11	Counter value	Counter value	UINT32	RO	0x00000000 (0 _{dec})
6000:12	Latch value	Latch value	UINT32	RO	0x00000000 (0 _{dec})
6000:16	Timestamp	Timestamp of the last counter change	UINT32	RO	0x00000000 (0 _{dec})

Index 6010 ENC Inputs Ch.2

Index (hex)	Name	Meaning	Data type	Flags	Default
6010:0	ENC Inputs Ch.2	Max. Subindex	UINT8	RO	0x16 (22 _{dec})
6010:02	Latch extern valid	The counter value was locked via the external latch. The data with the index 0x6010:12 [▶ 57] correspond to the latched value with the bit set. In order to re-activate the latch input, index 0x7010:02 [▶ 59] or object index 0x7010:04 [▶ 59] must first be cancelled and then set again.	BOOLEAN	RO	0x00 (0 _{dec})
6010:03	Set counter done	The counter was set.	BOOLEAN	RO	0x00 (0 _{dec})
6010:04	Counter underflow	Counter underflow. Overflow/underflow control is inactive in combination with a reset function (C/external).	BOOLEAN	RO	0x00 (0 _{dec})
6010:05	Counter overflow	Counter overflow. Overflow/underflow control is inactive in combination with a reset function (C/external).	BOOLEAN	RO	0x00 (0 _{dec})
6010:08	Extrapolation stall	The extrapolated part of the counter is invalid	BOOLEAN	RO	0x00 (0 _{dec})
6010:09	Status of input A	Status of input A	BOOLEAN	RO	0x00 (0 _{dec})
6010:0A	Status of input B	Status of input B	BOOLEAN	RO	0x00 (0 _{dec})
6010:0D	Status of extern latch	Status of the extern latch input	BOOLEAN	RO	0x00 (0 _{dec})
6010:0E	Sync error	The Sync error bit is only required for DC mode. It indicates whether a synchronization error has occurred during the previous cycle. This means a SYNC signal was triggered in the terminal, although no new process data were available (0=OK, 1=NOK).	BOOLEAN	RO	0x00 (0 _{dec})
6010:10	TxPDO Toggle	The TxPDO toggle is toggled by the slave when the data of the associated TxPDO is updated.	BOOLEAN	RO	0x00 (0 _{dec})
6010:11	Counter value	Counter value	UINT32	RO	0x00000000 (0 _{dec})
6010:12	Latch value	Latch value	UINT32	RO	0x00000000 (0 _{dec})
6010:16	Timestamp	Timestamp of the last counter change	UINT32	RO	0x00000000 (0 _{dec})

Index 6020 DCM Inputs Ch.1

Index (hex)	Name	Meaning	Data type	Flags	Default
6020:0	DCM Inputs Ch.1	Max. Subindex	UINT8	RO	0x12 (18 _{dec})
6020:01	Ready to enable	Driver stage is ready for enabling	BOOLEAN	RO	0x00 (0 _{dec})
6020:02	Ready	Driver stage is ready for operation	BOOLEAN	RO	0x00 (0 _{dec})
6020:03	Warning	A warning has occurred (see index 0xA020 [▶ 63])	BOOLEAN	RO	0x00 (0 _{dec})
6020:04	Error	An error has occurred (see index 0xA020 [▶ 63])	BOOLEAN	RO	0x00 (0 _{dec})
6020:05	Moving positive	Driver stage is activated in positive direction	BOOLEAN	RO	0x00 (0 _{dec})
6020:06	Moving negative	Driver stage is activated in negative direction	BOOLEAN	RO	0x00 (0 _{dec})
6020:07	Torque reduced	Reduced torque is active	BOOLEAN	RO	0x00 (0 _{dec})
6020:0C	Digital input 1	Digital input 1	BOOLEAN	RO	0x00 (0 _{dec})
6020:0D	Digital input 2	Digital input 2	BOOLEAN	RO	0x00 (0 _{dec})
6020:0E	Sync error	The Sync error bit is only required for DC mode. It indicates whether a synchronization error has occurred during the previous cycle.	BOOLEAN	RO	0x00 (0 _{dec})
6020:10	TxPDO Toggle	The TxPDO toggle is toggled by the slave when the data of the associated TxPDO is updated.	BOOLEAN	RO	0x00 (0 _{dec})
6020:11	Info data 1	Synchronous information (selection via subindex 0x8022:11)	UINT16	RO	0x0000 (0 _{dec})
6020:12	Info data 2	Synchronous information (selection via subindex 0x8022:19)	UINT16	RO	0x0000 (0 _{dec})

Index 6030 DCM Inputs Ch.2

Index (hex)	Name	Meaning	Data type	Flags	Default
6030:0	DCM Inputs Ch.2	Max. Subindex	UINT8	RO	0x12 (18 _{dec})
6030:01	Ready to enable	Driver stage is ready for enabling	BOOLEAN	RO	0x00 (0 _{dec})
6030:02	Ready	Driver stage is ready for operation	BOOLEAN	RO	0x00 (0 _{dec})
6030:03	Warning	A warning has occurred (see index 0xA030 [▶ 63])	BOOLEAN	RO	0x00 (0 _{dec})
6030:04	Error	An error has occurred (see index 0xA030 [▶ 63])	BOOLEAN	RO	0x00 (0 _{dec})
6030:05	Moving positive	Driver stage is activated in positive direction	BOOLEAN	RO	0x00 (0 _{dec})
6030:06	Moving negative	Driver stage is activated in negative direction	BOOLEAN	RO	0x00 (0 _{dec})
6030:07	Torque reduced	Reduced torque is active	BOOLEAN	RO	0x00 (0 _{dec})
6030:0C	Digital input 1	Digital input 1	BOOLEAN	RO	0x00 (0 _{dec})
6030:0D	Digital input 2	Digital input 2	BOOLEAN	RO	0x00 (0 _{dec})
6030:0E	Sync error	The Sync error bit is only required for DC mode. It indicates whether a synchronization error has occurred during the previous cycle.	BOOLEAN	RO	0x00 (0 _{dec})
6030:10	TxPDO Toggle	The TxPDO toggle is toggled by the slave when the data of the associated TxPDO is updated.	BOOLEAN	RO	0x00 (0 _{dec})
6030:11	Info data 1	Synchronous information (selection via subindex 0x8032:11)	UINT16	RO	0x0000 (0 _{dec})
6030:12	Info data 2	Synchronous information (selection via subindex 0x8032:19)	UINT16	RO	0x0000 (0 _{dec})

Index 6040 POS Inputs Ch.1

Index (hex)	Name	Meaning	Data type	Flags	Default
6040:0	POS Inputs Ch.1	Max. Subindex	UINT8	RO	0x22 (34 _{dec})
6040:01	Busy	A current travel command is active	BOOLEAN	RO	0x00 (0 _{dec})
6040:02	In-Target	Motor has arrived at target	BOOLEAN	RO	0x00 (0 _{dec})
6040:03	Warning	A warning has occurred	BOOLEAN	RO	0x00 (0 _{dec})
6040:04	Error	an error has occurred	BOOLEAN	RO	0x00 (0 _{dec})
6040:05	Calibrated	Motor is calibrated	BOOLEAN	RO	0x00 (0 _{dec})
6040:06	Accelerate	Motor is in the acceleration phase	BOOLEAN	RO	0x00 (0 _{dec})
6040:07	Decelerate	Motor is in the deceleration phase	BOOLEAN	RO	0x00 (0 _{dec})
6040:11	Actual position	Current target position of the travel command generator	UINT32	RO	0x00007FFF (32767 _{dec})
6040:21	Actual velocity	Current set velocity of the travel command generator	INT16	RO	0x0000 (0 _{dec})
6040:22	Actual drive time	Travel command time information (see subindex 0x8pp1:11)	UINT32	RO	0x00000000 (0 _{dec})

Index 6050 POS Inputs Ch.2

Index (hex)	Name	Meaning	Data type	Flags	Default
6050:0	POS Inputs Ch.2	Max. Subindex	UINT8	RO	0x22 (34 _{dec})
6050:01	Busy	A current travel command is active	BOOLEAN	RO	0x00 (0 _{dec})
6050:02	In-Target	Motor has arrived at target	BOOLEAN	RO	0x00 (0 _{dec})
6050:03	Warning	A warning has occurred	BOOLEAN	RO	0x00 (0 _{dec})
6050:04	Error	an error has occurred	BOOLEAN	RO	0x00 (0 _{dec})
6050:05	Calibrated	Motor is calibrated	BOOLEAN	RO	0x00 (0 _{dec})
6050:06	Accelerate	Motor is in the acceleration phase	BOOLEAN	RO	0x00 (0 _{dec})
6050:07	Decelerate	Motor is in the deceleration phase	BOOLEAN	RO	0x00 (0 _{dec})
6050:11	Actual position	Current target position of the travel command generator	UINT32	RO	0x00007FFF (32767 _{dec})
6050:21	Actual velocity	Current set velocity of the travel command generator	INT16	RO	0x0000 (0 _{dec})
6050:22	Actual drive time	Travel command time information (see subindex 0x8pp1:11)	UINT32	RO	0x00000000 (0 _{dec})

6.5 Output data

Index 7000 ENC Outputs Ch.1

Index (hex)	Name	Meaning	Data type	Flags	Default
7000:0	ENC Outputs Ch.1	Max. Subindex	UINT8	RO	0x11 (17 _{dec})
7000:02	Enable latch extern on positive edge	Activate external latch with positive edge.	BOOLEAN	RO	0x00 (0 _{dec})
7000:03	Set counter	Set counter	BOOLEAN	RO	0x00 (0 _{dec})
7000:04	Enable latch extern on negative edge	Activate external latch with negative edge.	BOOLEAN	RO	0x00 (0 _{dec})
7000:11	Set counter value	The counter value to be set via "Set counter" (index 0x7000:03).	UINT32	RO	0x00000000 (0 _{dec})

Index 7010 ENC Outputs Ch.2

Index (hex)	Name	Meaning	Data type	Flags	Default
7010:0	ENC Outputs Ch.2	Max. Subindex	UINT8	RO	0x11 (17 _{dec})
7010:02	Enable latch extern on positive edge	Activate external latch with positive edge.	BOOLEAN	RO	0x00 (0 _{dec})
7010:03	Set counter	Set counter	BOOLEAN	RO	0x00 (0 _{dec})
7010:04	Enable latch extern on negative edge	Activate external latch with negative edge.	BOOLEAN	RO	0x00 (0 _{dec})
7010:11	Set counter value	The counter value to be set via "Set counter" (index 0x7010:03).	UINT32	RO	0x00000000 (0 _{dec})

Index 7020 DCM Outputs Ch.1

Index (hex)	Name	Meaning	Data type	Flags	Default
7020:0	DCM Outputs Ch.1	Max. Subindex	UINT8	RO	0x21 (33 _{dec})
7020:01	Enable	Activates the output stage	BOOLEAN	RO	0x00 (0 _{dec})
7020:02	Reset	All errors that may have occurred are reset by setting this bit (rising edge)	BOOLEAN	RO	0x00 (0 _{dec})
7020:03	Reduce torque	Reduced torque (coil current) is active (see subindex 0x8020:05 / 0x8020:06)	BOOLEAN	RO	0x00 (0 _{dec})
7020:11	Position	Set position specification	UINT32	RO	0x00000000 (0 _{dec})
7020:21	Velocity	Set velocity specification	INT16	RO	0x0000 (0 _{dec})

Index 7030 DCM Outputs Ch.2

Index (hex)	Name	Meaning	Data type	Flags	Default
7030:0	DCM Outputs Ch.2	Max. Subindex	UINT8	RO	0x21 (33 _{dec})
7030:01	Enable	Activates the output stage	BOOLEAN	RO	0x00 (0 _{dec})
7030:02	Reset	All errors that may have occurred are reset by setting this bit (rising edge)	BOOLEAN	RO	0x00 (0 _{dec})
7030:03	Reduce torque	Reduced torque (coil current) is active (see subindex 0x8030:05 / 0x8030:06)	BOOLEAN	RO	0x00 (0 _{dec})
7030:11	Position	Set position specification	UINT32	RO	0x00000000 (0 _{dec})
7030:21	Velocity	Set velocity specification	INT16	RO	0x0000 (0 _{dec})

Index 7040 POS Outputs Ch.1

Index (hex)	Name	Meaning	Data type	Flags	Default
7040:0	POS Outputs Ch.1	Max. Subindex	UINT8	RO	0x24 (36 _{dec})
7040:01	Execute	Start travel command (rising edge), or prematurely abort travel command (falling edge)	BOOLEAN	RO	0x00 (0 _{dec})
7040:02	Emergency stop	Prematurely abort travel command with an emergency ramp (rising edge)	BOOLEAN	RO	0x00 (0 _{dec})
7040:11	Target position	Specification of the target position	UINT32	RO	0x00007FFF (32767 _{dec})
7040:21	Velocity	Specification of the maximum set velocity	INT16	RO	0x0000 (0 _{dec})
7040:22	Start type	Specification of the start types 0x0000 Idle No travel command is being executed 0x0001 Absolute Absolute target position 0x0002 Relative Target position relative to the start position 0x0003 Endless plus Endless driving in positive direction of rotation 0x0004 Endless minus Endless driving in negative direction of rotation 0x0105 Modulo short Shortest distance to the next modulo position 0x0115 Modulo short extended Shortest distance to the next modulo position (without modulo window) 0x0205 Modulo plus Drive in positive direction of rotation to the next modulo position 0x0215 Modulo plus extended Drive in positive direction of rotation to the next modulo position (without modulo window) 0x0305 Modulo minus Drive in negative direction of rotation to the next modulo position 0x0315 Modulo minus extended Drive in negative direction of rotation to the next modulo position (without modulo window) 0x0405 Modulo current Drive in the last implemented direction of rotation to the next modulo position 0x0415 Modulo current extended Drive in the last implemented direction of rotation to the next modulo position (without modulo window) 0x0006 Additive New target position relative/additive to the last target position 0x6000 Calibration, Plc cam Calibration with cam 0x6100 Calibration, Hw sync Calibration with cam and C-track 0x6E00 Calibration, set manual Set calibration manually 0x6E01 Calibration, set manual auto Set calibration automatically 0x6F00 Calibration, clear manual Clear calibration manually	UINT16	RO	0x0000 (0 _{dec})
7040:23	Acceleration	Acceleration specification	UINT16	RO	0x0000 (0 _{dec})
7040:24	Deceleration	Deceleration specification	UINT16	RO	0x0000 (0 _{dec})

Index 7050 POS Outputs Ch.2

Index (hex)	Name	Meaning	Data type	Flags	Default
7050:0	POS Outputs Ch.2	Max. Subindex	UINT8	RO	0x24 (36 _{dec})
7050:01	Execute	Start travel command (rising edge), or prematurely abort travel command (falling edge)	BOOLEAN	RO	0x00 (0 _{dec})
7050:02	Emergency Stop	Prematurely abort travel command with an emergency ramp (rising edge)	BOOLEAN	RO	0x00 (0 _{dec})
7050:11	Target position	Specification of the target position	UINT32	RO	0x00007FFF (32767 _{dec})
7050:21	Velocity	Specification of the maximum set velocity	INT16	RO	0x0000 (0 _{dec})
7050:22	Start type	Specification of the start types 0x0000 Idle No travel command is being executed 0x0001 Absolute Absolute target position 0x0002 Relative Target position relative to the start position 0x0003 Endless plus Endless driving in positive direction of rotation 0x0004 Endless minus Endless driving in negative direction of rotation 0x0105 Modulo short Shortest distance to the next modulo position 0x0115 Modulo short extended Shortest distance to the next modulo position (without modulo window) 0x0205 Modulo plus Drive in positive direction of rotation to the next modulo position 0x0215 Modulo plus extended Drive in positive direction of rotation to the next modulo position (without modulo window) 0x0305 Modulo minus Drive in negative direction of rotation to the next modulo position 0x0315 Modulo minus extended Drive in negative direction of rotation to the next modulo position (without modulo window) 0x0405 Modulo current Drive in the last implemented direction of rotation to the next modulo position 0x0415 Modulo current extended Drive in the last implemented direction of rotation to the next modulo position (without modulo window) 0x0006 Additive New target position relative/additive to the last target position 0x6000 Calibration, Plc cam Calibration with cam 0x6100 Calibration, Hw sync Calibration with cam and C-track 0x6E00 Calibration, set manual Set calibration manually 0x6E01 Calibration, set manual auto Set calibration automatically 0x6F00 Calibration, clear manual Clear calibration manually	UINT16	RO	0x0000 (0 _{dec})
7050:23	Acceleration	Acceleration specification	UINT16	RO	0x0000 (0 _{dec})
7050:24	Deceleration	Deceleration specification	UINT16	RO	0x0000 (0 _{dec})

6.6 Information and diagnosis data (channel specific)

Index 9020 DCM Info data Ch.1

Index (hex)	Name	Meaning	Data type	Flags	Default
9020:0	DCM Info data Ch.1	Max. Subindex	UINT8	RO	0x09 (9 _{dec})
9020:01	Status word	Status word (see Index 0xApp0)	UINT16	RO	0x0000 (0 _{dec})
9020:02	Motor coil voltage	Present coil voltage	UINT16	RO	0x0000 (0 _{dec})
9020:03	Motor coil current	Present coil current	INT16	RO	0x0000 (0 _{dec})
9020:04	Current limit	Present current limit	UINT16	RO	0x0000 (0 _{dec})
9020:05	Control error	Present control error	INT16	RO	0x0000 (0 _{dec})
9020:06	Duty cycle	Present Duty-Cycle	INT8	RO	0x00 (0 _{dec})
9020:08	Motor velocity	Present motor velocity	INT16	RO	0x0000 (0 _{dec})
9020:09	Overload time	Time since overload	UINT16	RO	0x0000 (0 _{dec})

Index 9030 DCM Info data Ch.2

Index (hex)	Name	Meaning	Data type	Flags	Default
9030:0	DCM Info data Ch.2	Max. Subindex	UINT8	RO	0x09 (9 _{dec})
9030:01	Status word	Status word (see Index 0xApp0)	UINT16	RO	0x0000 (0 _{dec})
9030:02	Motor coil voltage	Present coil voltage	UINT16	RO	0x0000 (0 _{dec})
9030:03	Motor coil current	Present coil current	INT16	RO	0x0000 (0 _{dec})
9030:04	Current limit	Present current limit	UINT16	RO	0x0000 (0 _{dec})
9030:05	Control error	Present control error	INT16	RO	0x0000 (0 _{dec})
9030:06	Duty cycle	Present Duty-Cycle	INT8	RO	0x00 (0 _{dec})
9030:08	Motor velocity	Present motor velocity	INT16	RO	0x0000 (0 _{dec})
9030:09	Overload time	Time since overload	UINT16	RO	0x0000 (0 _{dec})

Index 9040 POS Info data Ch.1

Index (hex)	Name	Meaning	Data type	Flags	Default
9040:0	POS Info data Ch.1	Max. Subindex	UINT8	RO	0x04 (4 _{dec})
9040:01	Status word	Status word	UINT16		0x0000 (0 _{dec})
9040:03	State (drive controller)	Current step of the internal state machine	UINT16	RO	0xFFFF (65535 _{dec})
9040:04	Actual position lag	Current position lag	UINT16		0x0000 (0 _{dec})

Index 9050 POS Info data Ch.2

Index (hex)	Name	Meaning	Data type	Flags	Default
9050:0	POS Info data Ch.2	Max. Subindex	UINT8	RO	0x04 (4 _{dec})
9050:01	Status word	Status word	UINT16	RO	0x0000 (0 _{dec})
9050:03	State (drive controller)	Current step of the internal state machine	UINT16	RO	0xFFFF (65535 _{dec})
9050:04	Actual position lag	Current position lag	UINT16	RO	0x0000 (0 _{dec})

Index A020 DCM Diag data Ch.1

Index (hex)	Name	Meaning	Data type	Flags	Default	
A020:0	DCM Diag data Ch.1	Max. Subindex	UINT8	RO	0x11 (17 _{dec})	
A020:01	Saturated	Driver stage operates with maximum duty cycle	Warning	BOOLEAN	RO	0x00 (0 _{dec})
A020:02	Over temperature	Internal terminal temperature is greater than 80 °C	Warning	BOOLEAN	RO	0x00 (0 _{dec})
A020:03	Torque overload	Present motor current exceeds the nominal current (see 0x8020:02)	Warning (0x8022:0A = 0) / Error (0x8022:0A = 1)	BOOLEAN	RO	0x00 (0 _{dec})
A020:04	Under voltage	Supply voltage less than 7 V	Error	BOOLEAN	RO	0x00 (0 _{dec})
A020:05	Over voltage	Supply voltage 10 % higher than the nominal voltage (see 0x8020:03)	Error	BOOLEAN	RO	0x00 (0 _{dec})
A020:06	Short circuit	Short circuit in the driver stage	Error	BOOLEAN	RO	0x00 (0 _{dec})
A020:08	No control power	No power supply to driver stage	Error	BOOLEAN	RO	0x00 (0 _{dec})
A020:09	Misc error	<ul style="list-style-type: none"> • initialization failed or • internal temperature of the terminal exceeds 100 °C (see 0xF80F:05) or • motor current exceeds the nominal current (see 0x8022:0A) 	Error	BOOLEAN	RO	0x00 (0 _{dec})
A020:0A	Configuration	CoE change has not yet been adopted into the current configuration.	Warning	BOOLEAN	RO	0x00 (0 _{dec})
A020:11	Actual operation mode	Present operating mode (in the case of automatic detection of operating mode, see 0x8022:01)		BIT4	RO	0x00 (0 _{dec})

Index A030 DCM Diag data Ch.2

Index (hex)	Name	Meaning	Data type	Flags	Default	
A030:0	DCM Diag data Ch.1	Max. Subindex	UINT8	RO	0x11 (17 _{dec})	
A030:01	Saturated	Driver stage operates with maximum duty cycle	Warning	BOOLEAN	RO	0x00 (0 _{dec})
A030:02	Over temperature	Internal terminal temperature is greater than 80 °C	Warning	BOOLEAN	RO	0x00 (0 _{dec})
A030:03	Torque overload	Present motor current exceeds the nominal current (see 0x8030:02)	Warning (0x8032:0A = 0) / Error (0x8032:0A = 1)	BOOLEAN	RO	0x00 (0 _{dec})
A030:04	Under voltage	Supply voltage less than 7 V	Error	BOOLEAN	RO	0x00 (0 _{dec})
A030:05	Over voltage	Supply voltage 10 % higher than the nominal voltage (see 0x8030:03)	Error	BOOLEAN	RO	0x00 (0 _{dec})
A030:06	Short circuit	Short circuit in the driver stage	Error	BOOLEAN	RO	0x00 (0 _{dec})
A030:08	No control power	No power supply to driver stage	Error	BOOLEAN	RO	0x00 (0 _{dec})
A030:09	Misc error	<ul style="list-style-type: none"> • initialization failed or • internal temperature of the terminal exceeds 100 °C (see 0xF80F:05) or • motor current exceeds the nominal current (see 0x8032:0A) 	Error	BOOLEAN	RO	0x00 (0 _{dec})
A030:0A	Configuration	CoE change has not yet been adopted into the current configuration.	Warning	BOOLEAN	RO	0x00 (0 _{dec})
A030:11	Actual operation mode	Present operating mode (in the case of automatic detection of operating mode, see 0x8032:01)		BIT4	RO	0x00 (0 _{dec})

Index A040 POS Diag data Ch.1

Index (hex)	Name	Meaning	Data type	Flags	Default
A040:0	POS Diag data Ch.1	Max. Subindex	UINT8	RO	0x6 (6 _{dec})
A040:01	Command rejected	Travel command was rejected	BOOLEAN	RO	0x00 (0 _{dec})
A040:02	Command aborted	Travel command was aborted	BOOLEAN	RO	0x00 (0 _{dec})
A040:03	Target overrun	Target position was overrun in the opposite direction	BOOLEAN	RO	0x00 (0 _{dec})
A040:04	Target timeout	The motor did not reach the target window (0x8040:0B) within the configured time (0x8040:0C) after the end of the travel command.	BOOLEAN	RO	0x00 (0 _{dec})
A040:05	Position lag	Position lag exceeded <ul style="list-style-type: none"> The position lag monitoring is deactivated if "Position lag max." = 0. If a value is entered in "Position lag max.", then this value is compared with "Actual position lag". As soon as "Actual position lag" exceeds "Position lag max.", "Position lag" = 1 is set and a PDO warning is output. 	BOOLEAN	RO	0x00 (0 _{dec})
A040:06	Emergency stop	An emergency stop was triggered (automatic or manual).	BOOLEAN	RO	0x00 (0 _{dec})

Index A050 POS Diag data Ch.2

Index (hex)	Name	Meaning	Data type	Flags	Default
A050:0	POS Diag data Ch.2	Max. Subindex	UINT8	RO	0x6 (6 _{dec})
A050:01	Command rejected	Travel command was rejected	BOOLEAN	RO	0x00 (0 _{dec})
A050:02	Command aborted	Travel command was aborted	BOOLEAN	RO	0x00 (0 _{dec})
A050:03	Target overrun	Target position was overrun in the opposite direction	BOOLEAN	RO	0x00 (0 _{dec})
A050:04	Target timeout	The motor did not reach the target window (0x8050:0B) within the configured time (0x8050:0C) after the end of the travel command.	BOOLEAN	RO	0x00 (0 _{dec})
A050:05	Position lag	Position lag exceeded <ul style="list-style-type: none"> The position lag monitoring is deactivated if "Position lag max." = 0. If a value is entered in "Position lag max.", then this value is compared with "Actual position lag". As soon as "Actual position lag" exceeds "Position lag max.", "Position lag" = 1 is set and a PDO warning is output. 	BOOLEAN	RO	0x00 (0 _{dec})
A050:06	Emergency stop	An emergency stop was triggered (automatic or manual).	BOOLEAN	RO	0x00 (0 _{dec})

6.7 Configuration data (vendor-specific)

Index F80F DCM Vendor data

Index (hex)	Name	Meaning	Data type	Flags	Default
F80F:0	DCM Vendor data	Max. Subindex	UINT8	RO	0x06 (6 _{dec})
F80F:01	PWM Frequency	DC link frequency (unit: 1 Hz)	UINT16	RW	0x7530 (30000 _{dec})
F80F:02	Deadtime	Dead time for pulse width modulation	UINT16	RW	0x0102 (258 _{dec})
F80F:03	Deadtime space	Duty cycle limitation	UINT16	RW	0x0009 (9 _{dec})
F80F:04	Warning temperature	Threshold of the temperature warning (unit: 1 °C)	INT8	RW	0x50 (80 _{dec})
F80F:05	Switch off temperature	Switch-off temperature (unit: 1 °C)	INT8	RW	0x64 (100 _{dec})
F80F:06	Analog trigger point	Trigger point for AD conversion	UINT16	RW	0x000A (10 _{dec})

6.8 Information and diagnosis data (device-specific)

Index F900 DCM Info data

Index (hex)	Name	Meaning	Data type	Flags	Default
F900:0	DCM Info data	Max. Subindex	UINT8	RO	0x06 (6 _{dec})
F900:01	Software version (driver)	Software version of the driver card	STRING	RO	
F900:02	Internal temperature	Internal terminal temperature (unit: 1 °C)	INT8	RO	0x00 (0 _{dec})
F900:04	Control voltage	Control voltage (unit: 1 mV)	UINT16	RO	0x0000 (0 _{dec})
F900:05	Motor supply voltage	Load voltage (unit: 1 mV)	UINT16	RO	0x0000 (0 _{dec})
F900:06	Cycle time	Measured cycle time (unit: 1 µs)	UINT16	RO	0x0000 (0 _{dec})

6.9 Standard objects

The standard objects have the same meaning for all EtherCAT slaves.

Index 1000 Device type

Index (hex)	Name	Meaning	Data type	Flags	Default
1000:0	Device type	Device type of the EtherCAT slave: the Lo-Word contains the CoE profile used (5001). The Hi-Word contains the module profile according to the modular device profile.	UINT32	RO	0x00001389 (5001 _{dec})

Index 1008 Device name

Index (hex)	Name	Meaning	Data type	Flags	Default
1008:0	Device name	Device name of the EtherCAT slave	STRING	RO	EPP7342-0002

Index 1009 Hardware version

Index (hex)	Name	Meaning	Data type	Flags	Default
1009:0	Hardware version	Hardware version of the EtherCAT slave	STRING	RO	¹⁾

¹⁾ Refer to [Firmware and hardware versions \[► 7\]](#).

Index 100A Software version

Index (hex)	Name	Meaning	Data type	Flags	Default
100A:0	Software version	Firmware version of the EtherCAT slave	STRING	RO	¹⁾

¹⁾ Refer to [Firmware and hardware versions \[► 7\]](#).

Index 1018 Identity

Index (hex)	Name	Meaning	Data type	Flags	Default
1018:0	Identity	Information for identifying the slave	UINT8	RO	0x04 (4 _{dec})
1018:01	Vendor ID	Vendor ID of the EtherCAT slave	UINT32	RO	0x00000002 (2 _{dec})
1018:02	Product code	Product code of the EtherCAT slave	UINT32	RO	0x647790E9 (1685557481 _{dec})
1018:03	Revision	Revision number of the EtherCAT slave; the Low Word (bit 0-15) indicates the special terminal number, the High Word (bit 16-31) refers to the device description	UINT32	RO	-
1018:04	Serial number	Serial number of the EtherCAT slave; the Low Byte (bit 0-7) of the Low Word contains the year of production, the High Byte (bit 8-15) of the Low Word contains the week of production, the High Word (bit 16-31) is 0	UINT32	RO	0x00000000 (0 _{dec})

Index 10F0 Backup parameter handling

Index (hex)	Name	Meaning	Data type	Flags	Default
10F0:0	Backup parameter handling	Information for standardized loading and saving of backup entries	UINT8	RO	0x01 (1 _{dec})
10F0:01	Checksum	Checksum across all backup entries of the EtherCAT slave	UINT32	RO	0x00000000 (0 _{dec})

Index 1400 ENC RxPDO-Par Control compact Ch.1

Index (hex)	Name	Meaning	Data type	Flags	Default
1400:0	ENC RxPDO-Par Control compact Ch.1	PDO Parameter RxPDO 1	UINT8	RO	0x06 (6 _{dec})
1400:06	Exclude RxPDOs	Specifies the RxPDOs (index of RxPDO mapping objects) that must not be transferred together with RxPDO 1	OCTET-STRING[6]	RO	01 16 00 00 00 00

Index 1401 ENC RxPDO-Par Control Ch.1

Index (hex)	Name	Meaning	Data type	Flags	Default
1401:0	ENC RxPDO-Par Control Ch.1	PDO Parameter RxPDO 2	UINT8	RO	0x06 (6 _{dec})
1401:06	Exclude RxPDOs	Specifies the RxPDOs (index of RxPDO mapping objects) that must not be transferred together with RxPDO 2	OCTET-STRING[6]	RO	00 16 00 00 00 00

Index 1402 ENC RxPDO-Par Control compact Ch.2

Index (hex)	Name	Meaning	Data type	Flags	Default
1402:0	ENC RxPDO-Par Control compact Ch.2	PDO Parameter RxPDO 3	UINT8	RO	0x06 (6 _{dec})
1402:06	Exclude RxPDOs	Specifies the RxPDOs (index of RxPDO mapping objects) that must not be transferred together with RxPDO 3	OCTET-STRING[6]	RO	03 16 00 00 00 00

Index 1403 ENC RxPDO-Par Control Ch.2

Index (hex)	Name	Meaning	Data type	Flags	Default
1403:0	ENC RxPDO-Par Control Ch.2	PDO Parameter RxPDO 4	UINT8	RO	0x06 (6 _{dec})
1403:06	Exclude RxPDOs	Specifies the RxPDOs (index of RxPDO mapping objects) that must not be transferred together with RxPDO 4	OCTET-STRING[6]	RO	02 16 00 00 00 00

Index 1405 DCM RxPDO-Par Position Ch.1

Index (hex)	Name	Meaning	Data type	Flags	Default
1405:0	DCM RxPDO-Par Position Ch.1	PDO Parameter RxPDO 6	UINT8	RO	0x06 (6 _{dec})
1405:06	Exclude RxPDOs	Specifies the RxPDOs (index of RxPDO mapping objects) that must not be transferred together with RxPDO 6	OCTET-STRING[6]	RO	06 16 0A 16 0B 16

Index 1406 DCM RxPDO-Par Velocity Ch.1

Index (hex)	Name	Meaning	Data type	Flags	Default
1406:0	DCM RxPDO-Par Velocity Ch.1	PDO Parameter RxPDO 7	UINT8	RO	0x06 (6 _{dec})
1406:06	Exclude RxPDOs	Specifies the RxPDOs (index of RxPDO mapping objects) that must not be transferred together with RxPDO 7	OCTET-STRING[6]	RO	05 16 0A 16 0B 16

Index 1408 DCM RxPDO-Par Position Ch.2

Index (hex)	Name	Meaning	Data type	Flags	Default
1408:0	DCM RxPDO-Par Position Ch.2	PDO Parameter RxPDO 9	UINT8	RO	0x06 (6 _{dec})
1408:06	Exclude RxPDOs	Specifies the RxPDOs (index of RxPDO mapping objects) that must not be transferred together with RxPDO 9	OCTET-STRING[6]	RO	09 16 0C 16 0D 16

Index 1409 DCM RxPDO-Par Velocity Ch.2

Index (hex)	Name	Meaning	Data type	Flags	Default
1409:0	DCM RxPDO-Par Velocity Ch.2	PDO Parameter RxPDO 10	UINT8	RO	0x06 (6 _{dec})
1409:06	Exclude RxPDOs	Specifies the RxPDOs (index of RxPDO mapping objects) that must not be transferred together with RxPDO 10	OCTET-STRING[6]	RO	08 16 0C 16 0D 16

Index 140A POS RxPDO-Par Control compact Ch.1

Index (hex)	Name	Meaning	Data type	Flags	Default
140A:0	POS RxPDO-Par Control compact Ch.1	PDO Parameter RxPDO 11	UINT8	RO	0x06 (6 _{dec})
140A:06	Exclude RxPDOs	Specifies the RxPDOs (index of RxPDO mapping objects) that must not be transferred together with RxPDO 11	OCTET-STRING[6]	RO	05 16 06 16 0B 16

Index 140B POS RxPDO-Par Control Ch.1

Index (hex)	Name	Meaning	Data type	Flags	Default
140B:0	POS RxPDO-Par Control Ch.1	PDO Parameter RxPDO 12	UINT8	RO	0x06 (6 _{dec})
140B:06	Exclude RxPDOs	Specifies the RxPDOs (index of RxPDO mapping objects) that must not be transferred together with RxPDO 12	OCTET-STRING[6]	RO	05 16 06 16 0A 16

Index 140C POS RxPDO-Par Control compact Ch.2

Index (hex)	Name	Meaning	Data type	Flags	Default
140C:0	POS RxPDO-Par Control compact Ch.2	PDO Parameter RxPDO 13	UINT8	RO	0x06 (6 _{dec})
140C:06	Exclude RxPDOs	Specifies the RxPDOs (index of RxPDO mapping objects) that must not be transferred together with RxPDO 13	OCTET-STRING[6]	RO	08 16 09 16 0D 16

Index 140D POS RxPDO-Par Control Ch.2

Index (hex)	Name	Meaning	Data type	Flags	Default
140D:0	POS RxPDO-Par Control Ch.2	PDO Parameter RxPDO 14	UINT8	RO	0x06 (6 _{dec})
140D:06	Exclude RxPDOs	Specifies the RxPDOs (index of RxPDO mapping objects) that must not be transferred together with RxPDO 14	OCTET-STRING[6]	RO	08 16 09 16 0C 16

Index 1600 ENC RxPDO-Map Control compact Ch.1

Index (hex)	Name	Meaning	Data type	Flags	Default
1600:0	ENC RxPDO-Map Control compact Ch.1	PDO Mapping RxPDO 1	UINT8	RO	0x07 (7 _{dec})
1600:01	SubIndex 001	1. PDO Mapping entry (1 bits align)	UINT32	RO	0x0000:00, 1
1600:02	SubIndex 002	2. PDO Mapping entry (object 0x7000 (ENC Outputs Ch.1), entry 0x02 (Enable latch extern on positive edge))	UINT32	RO	0x7000:02, 1
1600:03	SubIndex 003	3. PDO Mapping entry (object 0x7000 (ENC Outputs Ch.1), entry 0x03 (Set counter))	UINT32	RO	0x7000:03, 1
1600:04	SubIndex 004	4. PDO Mapping entry (object 0x7000 (ENC Outputs Ch.1), entry 0x04 (Enable latch extern on negative edge))	UINT32	RO	0x7000:04, 1
1600:05	SubIndex 005	5. PDO Mapping entry (4 bits align)	UINT32	RO	0x0000:00, 4
1600:06	SubIndex 006	6. PDO Mapping entry (8 bits align)	UINT32	RO	0x0000:00, 8
1600:07	SubIndex 007	7. PDO Mapping entry (object 0x7000 (ENC Outputs Ch.1), entry 0x11 (Set counter value))	UINT32	RO	0x7000:11, 16

Index 1601 ENC RxPDO-Map Control Ch.1

Index (hex)	Name	Meaning	Data type	Flags	Default
1601:0	ENC RxPDO-Map Control Ch.1	PDO Mapping RxPDO 2	UINT8	RO	0x07 (7 _{dec})
1601:01	SubIndex 001	1. PDO Mapping entry (1 bits align)	UINT32	RO	0x0000:00, 1
1601:02	SubIndex 002	2. PDO Mapping entry (object 0x7000 (ENC Outputs Ch.1), entry 0x02 (Enable latch extern on positive edge))	UINT32	RO	0x7000:02, 1
1601:03	SubIndex 003	3. PDO Mapping entry (object 0x7000 (ENC Outputs Ch.1), entry 0x03 (Set counter))	UINT32	RO	0x7000:03, 1
1601:04	SubIndex 004	4. PDO Mapping entry (object 0x7000 (ENC Outputs Ch.1), entry 0x04 (Enable latch extern on negative edge))	UINT32	RO	0x7000:04, 1
1601:05	SubIndex 005	5. PDO Mapping entry (4 bits align)	UINT32	RO	0x0000:00, 4
1601:06	SubIndex 006	6. PDO Mapping entry (8 bits align)	UINT32	RO	0x0000:00, 8
1601:07	SubIndex 007	7. PDO Mapping entry (object 0x7000 (ENC Outputs Ch.1), entry 0x11 (Set counter value))	UINT32	RO	0x7000:11, 32

Index 1602 ENC RxPDO-Map Control compact Ch.2

Index (hex)	Name	Meaning	Data type	Flags	Default
1602:0	ENC RxPDO-Map Control compact Ch.2	PDO Mapping RxPDO 3	UINT8	RO	0x07 (7 _{dec})
1602:01	SubIndex 001	1. PDO Mapping entry (1 bits align)	UINT32	RO	0x0000:00, 1
1602:02	SubIndex 002	2. PDO Mapping entry (object 0x7010 (ENC Outputs Ch.2), entry 0x02 (Enable latch extern on positive edge))	UINT32	RO	0x7010:02, 1
1602:03	SubIndex 003	3. PDO Mapping entry (object 0x7010 (ENC Outputs Ch.2), entry 0x03 (Set counter))	UINT32	RO	0x7010:03, 1
1602:04	SubIndex 004	4. PDO Mapping entry (object 0x7010 (ENC Outputs Ch.2), entry 0x04 (Enable latch extern on negative edge))	UINT32	RO	0x7010:04, 1
1602:05	SubIndex 005	5. PDO Mapping entry (4 bits align)	UINT32	RO	0x0000:00, 4
1602:06	SubIndex 006	6. PDO Mapping entry (8 bits align)	UINT32	RO	0x0000:00, 8
1602:07	SubIndex 007	7. PDO Mapping entry (object 0x7010 (ENC Outputs Ch.2), entry 0x11 (Set counter value))	UINT32	RO	0x7010:11, 16

Index 1603 ENC RxPDO-Map Control Ch.2

Index (hex)	Name	Meaning	Data type	Flags	Default
1603:0	ENC RxPDO-Map Control Ch.2	PDO Mapping RxPDO 4	UINT8	RO	0x07 (7 _{dec})
1603:01	SubIndex 001	1. PDO Mapping entry (1 bits align)	UINT32	RO	0x0000:00, 1
1603:02	SubIndex 002	2. PDO Mapping entry (object 0x7010 (ENC Outputs Ch.2), entry 0x02 (Enable latch extern on positive edge))	UINT32	RO	0x7010:02, 1
1603:03	SubIndex 003	3. PDO Mapping entry (object 0x7010 (ENC Outputs Ch.2), entry 0x03 (Set counter))	UINT32	RO	0x7010:03, 1
1603:04	SubIndex 004	4. PDO Mapping entry (object 0x7010 (ENC Outputs Ch.2), entry 0x04 (Enable latch extern on negative edge))	UINT32	RO	0x7010:04, 1
1603:05	SubIndex 005	5. PDO Mapping entry (4 bits align)	UINT32	RO	0x0000:00, 4
1603:06	SubIndex 006	6. PDO Mapping entry (8 bits align)	UINT32	RO	0x0000:00, 8
1603:07	SubIndex 007	7. PDO Mapping entry (object 0x7010 (ENC Outputs Ch.2), entry 0x11 (Set counter value))	UINT32	RO	0x7010:11, 32

Index 1604 DCM RxPDO-Map Control Ch.1

Index (hex)	Name	Meaning	Data type	Flags	Default
1604:0	DCM RxPDO-Map Control Ch.1	PDO Mapping RxPDO 5	UINT8	RO	0x05 (5 _{dec})
1604:01	SubIndex 001	1. PDO Mapping entry (object 0x7020 (DCM Outputs Ch.1), entry 0x01 (Enable))	UINT32	RO	0x7020:01, 1
1604:02	SubIndex 002	2. PDO Mapping entry (object 0x7020 (DCM Outputs Ch.1), entry 0x02 (Reset))	UINT32	RO	0x7020:02, 1
1604:03	SubIndex 003	3. PDO Mapping entry (object 0x7020 (DCM Outputs Ch.1), entry 0x03 (Reduce torque))	UINT32	RO	0x7020:03, 1
1604:04	SubIndex 004	4. PDO Mapping entry (5 bits align)	UINT32	RO	0x0000:00, 5
1604:05	SubIndex 005	5. PDO Mapping entry (8 bits align)	UINT32	RO	0x0000:00, 8

Index 1605 DCM RxPDO-Map Position Ch.1

Index (hex)	Name	Meaning	Data type	Flags	Default
1605:0	DCM RxPDO-Map Position Ch.1	PDO Mapping RxPDO 6	UINT8	RO	0x01 (1 _{dec})
1605:01	SubIndex 001	1. PDO Mapping entry (object 0x7020 (DCM Outputs Ch.1), entry 0x11 (Position))	UINT32	RO	0x7020:11, 32

Index 1606 DCM RxPDO-Map Velocity Ch.1

Index (hex)	Name	Meaning	Data type	Flags	Default
1606:0	DCM RxPDO-Map Velocity Ch.1	PDO Mapping RxPDO 7	UINT8	RO	0x01 (1 _{dec})
1606:01	SubIndex 001	1. PDO Mapping entry (object 0x7020 (DCM Outputs Ch.1), entry 0x21 (Velocity))	UINT32	RO	0x7020:21, 16

Index 1607 DCM RxPDO-Map Control Ch.2

Index (hex)	Name	Meaning	Data type	Flags	Default
1607:0	DCM RxPDO-Map Control Ch.2	PDO Mapping RxPDO 8	UINT8	RO	0x05 (5 _{dec})
1607:01	SubIndex 001	1. PDO Mapping entry (object 0x7030 (DCM Outputs Ch.2), entry 0x01 (Enable))	UINT32	RO	0x7030:01, 1
1607:02	SubIndex 002	2. PDO Mapping entry (object 0x7030 (DCM Outputs Ch.2), entry 0x02 (Reset))	UINT32	RO	0x7030:02, 1
1607:03	SubIndex 003	3. PDO Mapping entry (object 0x7030 (DCM Outputs Ch.2), entry 0x03 (Reduce torque))	UINT32	RO	0x7030:03, 1
1607:04	SubIndex 004	4. PDO Mapping entry (5 bits align)	UINT32	RO	0x0000:00, 5
1607:05	SubIndex 005	5. PDO Mapping entry (8 bits align)	UINT32	RO	0x0000:00, 8

Index 1608 DCM RxPDO-Map Position Ch.2

Index (hex)	Name	Meaning	Data type	Flags	Default
1608:0	DCM RxPDO-Map Position Ch.2	PDO Mapping RxPDO 9	UINT8	RO	0x01 (1 _{dec})
1608:01	SubIndex 001	1. PDO Mapping entry (object 0x7030 (DCM Outputs Ch.2), entry 0x11 (Position))	UINT32	RO	0x7030:11, 32

Index 1609 DCM RxPDO-Map Velocity Ch.2

Index (hex)	Name	Meaning	Data type	Flags	Default
1609:0	DCM RxPDO-Map Velocity Ch.2	PDO Mapping RxPDO 10	UINT8	RO	0x01 (1 _{dec})
1609:01	SubIndex 001	1. PDO Mapping entry (object 0x7030 (DCM Outputs Ch.2), entry 0x21 (Velocity))	UINT32	RO	0x7030:21, 16

Index 160A POS RxPDO-Map Control compact Ch.1

Index (hex)	Name	Meaning	Data type	Flags	Default
160A:0	POS RxPDO-Map Control compact Ch.1	PDO Mapping RxPDO 11	UINT8	RO	0x05 (5 _{dec})
160A:01	SubIndex 001	1. PDO Mapping entry (object 0x7040 (POS Outputs Ch.1), entry 0x01 (Execute))	UINT32	RO	0x7040:01, 1
160A:02	SubIndex 002	2. PDO Mapping entry (object 0x7040 (POS Outputs Ch.1), entry 0x02 (Emergency stop))	UINT32	RO	0x7040:02, 1
160A:03	SubIndex 003	3. PDO Mapping entry (6 bits align)	UINT32	RO	0x0000:00, 6
160A:04	SubIndex 004	4. PDO Mapping entry (8 bits align)	UINT32	RO	0x0000:00, 8
160A:05	SubIndex 005	5. PDO Mapping entry (object 0x7040 (POS Outputs Ch.1), entry 0x11 (Target position))	UINT32	RO	0x7040:11, 32

Index 160B POS RxPDO-Map Control Ch.1

Index (hex)	Name	Meaning	Data type	Flags	Default
160B:0	POS RxPDO-Map Control Ch.1	PDO Mapping RxPDO 12	UINT8	RO	0x09 (9 _{dec})
160B:01	SubIndex 001	1. PDO Mapping entry (object 0x7040 (POS Outputs Ch.1), entry 0x01 (Execute))	UINT32	RO	0x7040:01, 1
160B:02	SubIndex 002	2. PDO Mapping entry (object 0x7040 (POS Outputs Ch.1), entry 0x02 (Emergency stop))	UINT32	RO	0x7040:02, 1
160B:03	SubIndex 003	3. PDO Mapping entry (6 bits align)	UINT32	RO	0x0000:00, 6
160B:04	SubIndex 004	4. PDO Mapping entry (8 bits align)	UINT32	RO	0x0000:00, 8
160B:05	SubIndex 005	5. PDO Mapping entry (object 0x7040 (POS Outputs Ch.1), entry 0x11 (Target position))	UINT32	RO	0x7040:11, 32
160B:06	SubIndex 006	6. PDO Mapping entry (object 0x7040 (POS Outputs Ch.1), entry 0x21 (Velocity))	UINT32	RO	0x7040:21, 16
160B:07	SubIndex 007	7. PDO Mapping entry (object 0x7040 (POS Outputs Ch.1), entry 0x22 (Start type))	UINT32	RO	0x7040:22, 16
160B:08	SubIndex 008	8. PDO Mapping entry (object 0x7040 (POS Outputs Ch.1), entry 0x23 (Acceleration))	UINT32	RO	0x7040:23, 16
160B:09	SubIndex 009	9. PDO Mapping entry (object 0x7040 (POS Outputs Ch.1), entry 0x24 (Deceleration))	UINT32	RO	0x7040:24, 16

Index 160C POS RxPDO-Map Control compact Ch.2

Index (hex)	Name	Meaning	Data type	Flags	Default
160C:0	POS RxPDO-Map Control compact Ch.2	PDO Mapping RxPDO 13	UINT8	RO	0x05 (5 _{dec})
160C:01	SubIndex 001	1. PDO Mapping entry (object 0x7050 (POS Outputs Ch.2), entry 0x01 (Execute))	UINT32	RO	0x7050:01, 1
160C:02	SubIndex 002	2. PDO Mapping entry (object 0x7050 (POS Outputs Ch.2), entry 0x02 (Emergency stop))	UINT32	RO	0x7050:02, 1
160C:03	SubIndex 003	3. PDO Mapping entry (6 bits align)	UINT32	RO	0x0000:00, 6
160C:04	SubIndex 004	4. PDO Mapping entry (8 bits align)	UINT32	RO	0x0000:00, 8
160C:05	SubIndex 005	5. PDO Mapping entry (object 0x7050 (POS Outputs Ch.2), entry 0x11 (Target position))	UINT32	RO	0x7050:11, 32

Index 160D POS RxPDO-Map Control Ch.2

Index (hex)	Name	Meaning	Data type	Flags	Default
160D:0	POS RxPDO-Map Control Ch.2	PDO Mapping RxPDO 14	UINT8	RO	0x09 (9 _{dec})
160D:01	SubIndex 001	1. PDO Mapping entry (object 0x7050 (POS Outputs Ch.2), entry 0x01 (Execute))	UINT32	RO	0x7050:01, 1
160D:02	SubIndex 002	2. PDO Mapping entry (object 0x7050 (POS Outputs Ch.2), entry 0x02 (Emergency stop))	UINT32	RO	0x7050:02, 1
160D:03	SubIndex 003	3. PDO Mapping entry (6 bits align)	UINT32	RO	0x0000:00, 6
160D:04	SubIndex 004	4. PDO Mapping entry (8 bits align)	UINT32	RO	0x0000:00, 8
160D:05	SubIndex 005	5. PDO Mapping entry (object 0x7050 (POS Outputs Ch.2), entry 0x11 (Target position))	UINT32	RO	0x7050:11, 32
160D:06	SubIndex 006	6. PDO Mapping entry (object 0x7050 (POS Outputs Ch.2), entry 0x21 (Velocity))	UINT32	RO	0x7050:21, 16
160D:07	SubIndex 007	7. PDO Mapping entry (object 0x7050 (POS Outputs Ch.2), entry 0x22 (Start type))	UINT32	RO	0x7050:22, 16
160D:08	SubIndex 008	8. PDO Mapping entry (object 0x7050 (POS Outputs Ch.2), entry 0x23 (Acceleration))	UINT32	RO	0x7050:23, 16
160D:09	SubIndex 009	9. PDO Mapping entry (object 0x7050 (POS Outputs Ch.2), entry 0x24 (Deceleration))	UINT32	RO	0x7050:24, 16

Index 1800 ENC TxPDO-Par Status compact Ch.1

Index (hex)	Name	Meaning	Data type	Flags	Default
1800:0	ENC TxPDO-Par Status compact Ch.1	PDO Parameter TxPDO 1	UINT8	RO	0x09 (9 _{dec})
1800:06	Exclude TxPDOs	Specifies the TxPDOs (index of TxPDO mapping objects) that must not be transferred together with TxPDO 1	OCTET-STRING[2]	RO	01 1A
1800:09	TxPDO Toggle	The TxPDO toggle is toggled with each update the corresponding input data	BOOLEAN	RO	0x00 (0 _{dec})

Index 1801 ENC TxPDO-Par Status Ch.1

Index (hex)	Name	Meaning	Data type	Flags	Default
1801:0	ENC TxPDO-Par Status Ch.1	PDO Parameter TxPDO 2	UINT8	RO	0x09 (9 _{dec})
1801:06	Exclude TxPDOs	Specifies the TxPDOs (index of TxPDO mapping objects) that must not be transferred together with TxPDO 2	OCTET-STRING[2]	RO	00 1A
1801:09	TxPDO Toggle	The TxPDO toggle is toggled with each update the corresponding input data	BOOLEAN	RO	0x00 (0 _{dec})

Index 1803 ENC TxPDO-Par Status compact Ch.2

Index (hex)	Name	Meaning	Data type	Flags	Default
1803:0	ENC TxPDO-Par Status compact Ch.2	PDO Parameter TxPDO 4	UINT8	RO	0x09 (9 _{dec})
1803:06	Exclude TxPDOs	Specifies the TxPDOs (index of TxPDO mapping objects) that must not be transferred together with TxPDO 4	OCTET-STRING[2]	RO	04 1A
1803:09	TxPDO Toggle	The TxPDO toggle is toggled with each update the corresponding input data	BOOLEAN	RO	0x00 (0 _{dec})

Index 1804 ENC TxPDO-Par Status Ch.2

Index (hex)	Name	Meaning	Data type	Flags	Default
1804:0	ENC TxPDO-Par Status Ch.2	PDO Parameter TxPDO 5	UINT8	RO	0x09 (9 _{dec})
1804:06	Exclude TxPDOs	Specifies the TxPDOs (index of TxPDO mapping objects) that must not be transferred together with TxPDO 5	OCTET-STRING[2]	RO	03 1A
1804:09	TxPDO Toggle	The TxPDO toggle is toggled with each update the corresponding input data	BOOLEAN	RO	0x00 (0 _{dec})

Index 180A POS TxPDO-Par Status compact Ch.1

Index (hex)	Name	Meaning	Data type	Flags	Default
180A:0	POS TxPDO-Par Status compact Ch.1	PDO Parameter TxPDO 11	UINT8	RO	0x06 (6 _{dec})
180A:06	Exclude TxPDOs	Specifies the TxPDOs (index of TxPDO mapping objects) that must not be transferred together with TxPDO 11	OCTET-STRING[2]	RO	0B 1A

Index 180B POS TxPDO-Par Status Ch.1

Index (hex)	Name	Meaning	Data type	Flags	Default
180B:0	POS TxPDO-Par Status Ch.1	PDO Parameter TxPDO 12	UINT8	RO	0x06 (6 _{dec})
180B:06	Exclude TxPDOs	Specifies the TxPDOs (index of TxPDO mapping objects) that must not be transferred together with TxPDO 12	OCTET-STRING[2]	RO	0A 1A

Index 180C POS TxPDO-Par Status compact Ch.2

Index (hex)	Name	Meaning	Data type	Flags	Default
180C:0	POS TxPDO-Par Status compact Ch.2	PDO Parameter TxPDO 13	UINT8	RO	0x06 (6 _{dec})
180C:06	Exclude TxPDOs	Specifies the TxPDOs (index of TxPDO mapping objects) that must not be transferred together with TxPDO 13	OCTET-STRING[2]	RO	0D 1A

Index 180D POS TxPDO-Par Status Ch.2

Index (hex)	Name	Meaning	Data type	Flags	Default
180D:0	POS TxPDO-Par Status Ch.2	PDO Parameter TxPDO 14	UINT8	RO	0x06 (6 _{dec})
180D:06	Exclude TxPDOs	Specifies the TxPDOs (index of TxPDO mapping objects) that must not be transferred together with TxPDO 14	OCTET-STRING[2]	RO	0C 1A

Index 1A00 ENC TxPDO-Map Status compact Ch.1

Index (hex)	Name	Meaning	Data type	Flags	Default
1A00:0	ENC TxPDO-Map Status compact Ch.1	PDO Mapping TxPDO 1	UINT8	RO	0x11 (17 _{dec})
1A00:01	SubIndex 001	1. PDO Mapping entry (1 bits align)	UINT32	RO	0x0000:00, 1
1A00:02	SubIndex 002	2. PDO Mapping entry (object 0x6000 (ENC Inputs Ch.1), entry 0x02 (Latch extern valid))	UINT32	RO	0x6000:02, 1
1A00:03	SubIndex 003	3. PDO Mapping entry (object 0x6000 (ENC Inputs Ch.1), entry 0x03 (Set counter done))	UINT32	RO	0x6000:03, 1
1A00:04	SubIndex 004	4. PDO Mapping entry (object 0x6000 (ENC Inputs Ch.1), entry 0x04 (Counter underflow))	UINT32	RO	0x6000:04, 1
1A00:05	SubIndex 005	5. PDO Mapping entry (object 0x6000 (ENC Inputs Ch.1), entry 0x05 (Counter overflow))	UINT32	RO	0x6000:05, 1
1A00:06	SubIndex 006	6. PDO Mapping entry (2 bits align)	UINT32	RO	0x0000:00, 2
1A00:07	SubIndex 007	7. PDO Mapping entry (object 0x6000 (ENC Inputs Ch.1), entry 0x08 (Extrapolation stall))	UINT32	RO	0x6000:08, 1
1A00:08	SubIndex 008	8. PDO Mapping entry (object 0x6000 (ENC Inputs Ch.1), entry 0x09 (Status of input A))	UINT32	RO	0x6000:09, 1
1A00:09	SubIndex 009	9. PDO Mapping entry (object 0x6000 (ENC Inputs Ch.1), entry 0x0A (Status of input B))	UINT32	RO	0x6000:0A, 1
1A00:0A	SubIndex 010	10. PDO Mapping entry (1 bit align)	UINT32	RO	0x0000:00, 1
1A00:0B	SubIndex 011	11. PDO Mapping entry (1 bit align)	UINT32	RO	0x0000:00, 1
1A00:0C	SubIndex 012	12. PDO Mapping entry (object 0x6000 (ENC Inputs Ch.1), entry 0x0D (Status of extern latch))	UINT32	RO	0x6000:0D, 1
1A00:0D	SubIndex 013	13. PDO Mapping entry (object 0x1C32 (SM output parameter), entry 0x20 (Sync error))	UINT32	RO	0x1C32:20, 1
1A00:0E	SubIndex 014	14. PDO Mapping entry (1 bit align)	UINT32	RO	0x0000:00, 1
1A00:0F	SubIndex 015	15. PDO Mapping entry (object 0x1800 (ENC TxPDO-Par Status compact Ch.1), entry 0x09 (TxPDO Toggle))	UINT32	RO	0x1800:09, 1
1A00:10	SubIndex 016	16. PDO Mapping entry (object 0x6000 (ENC Inputs Ch.1), entry 0x11 (Counter value))	UINT32	RO	0x6000:11, 16
1A00:11	SubIndex 017	17. PDO Mapping entry (object 0x6000 (ENC Inputs Ch.1), entry 0x12 (Latch value))	UINT32	RO	0x6000:12, 16

Index 1A01 ENC TxPDO-Map Status Ch.1

Index (hex)	Name	Meaning	Data type	Flags	Default
1A01:0	ENC TxPDO-Map Status Ch.1	PDO Mapping TxPDO 2	UINT8	RO	0x11 (17 _{dec})
1A01:01	SubIndex 001	1. PDO Mapping entry (1 bits align)	UINT32	RO	0x0000:00, 1
1A01:02	SubIndex 002	2. PDO Mapping entry (object 0x6000 (ENC Inputs Ch.1), entry 0x02 (Latch extern valid))	UINT32	RO	0x6000:02, 1
1A01:03	SubIndex 003	3. PDO Mapping entry (object 0x6000 (ENC Inputs Ch.1), entry 0x03 (Set counter done))	UINT32	RO	0x6000:03, 1
1A01:04	SubIndex 004	4. PDO Mapping entry (object 0x6000 (ENC Inputs Ch.1), entry 0x04 (Counter underflow))	UINT32	RO	0x6000:04, 1
1A01:05	SubIndex 005	5. PDO Mapping entry (object 0x6000 (ENC Inputs Ch.1), entry 0x05 (Counter overflow))	UINT32	RO	0x6000:05, 1
1A01:06	SubIndex 006	6. PDO Mapping entry (2 bits align)	UINT32	RO	0x0000:00, 2
1A01:07	SubIndex 007	7. PDO Mapping entry (object 0x6000 (ENC Inputs Ch.1), entry 0x08 (Extrapolation stall))	UINT32	RO	0x6000:08, 1
1A01:08	SubIndex 008	8. PDO Mapping entry (object 0x6000 (ENC Inputs Ch.1), entry 0x09 (Status of input A))	UINT32	RO	0x6000:09, 1
1A01:09	SubIndex 009	9. PDO Mapping entry (object 0x6000 (ENC Inputs Ch.1), entry 0x0A (Status of input B))	UINT32	RO	0x6000:0A, 1
1A01:0A	SubIndex 010	10. PDO Mapping entry (1 bits align)	UINT32	RO	0x0000:00, 1
1A01:0B	SubIndex 011	11. PDO Mapping entry (1 bits align)	UINT32	RO	0x0000:00, 1
1A01:0C	SubIndex 012	12. PDO Mapping entry (object 0x6000 (ENC Inputs Ch.1), entry 0x0D (Status of extern latch))	UINT32	RO	0x6000:0D, 1
1A01:0D	SubIndex 013	13. PDO Mapping entry (object 0x1C32 (SM output parameter), entry 0x20 (Sync error))	UINT32	RO	0x1C32:20, 1
1A01:0E	SubIndex 014	14. PDO Mapping entry (1 bits align)	UINT32	RO	0x0000:00, 1
1A01:0F	SubIndex 015	15. PDO Mapping entry (object 0x1801 (ENC TxPDO-Par Status Ch.1), entry 0x09 (TxPDO Toggle))	UINT32	RO	0x1801:09, 1
1A01:10	SubIndex 016	16. PDO Mapping entry (object 0x6000 (ENC Inputs Ch.1), entry 0x11 (Counter value))	UINT32	RO	0x6000:11, 32
1A01:11	SubIndex 017	17. PDO Mapping entry (object 0x6000 (ENC Inputs Ch.1), entry 0x12 (Latch value))	UINT32	RO	0x6000:12, 32

Index 1A02 ENC TxPDO-Map Timest. compact Ch.1

Index (hex)	Name	Meaning	Data type	Flags	Default
1A02:0	ENC TxPDO-Map Timest. compact Ch.1	PDO Mapping TxPDO 3	UINT8	RO	0x01 (1 _{dec})
1A02:01	SubIndex 001	1. PDO Mapping entry (object 0x6000 (ENC Inputs Ch.1), entry 0x16 (Timestamp))	UINT32	RO	0x6000:16, 32

Index 1A03 ENC TxPDO-Map Status compact Ch.2

Index (hex)	Name	Meaning	Data type	Flags	Default
1A03:0	ENC TxPDO-Map Status compact Ch.2	PDO Mapping TxPDO 4	UINT8	RO	0x11 (17 _{dec})
1A03:01	SubIndex 001	1. PDO Mapping entry (1 bit align)	UINT32	RO	0x0000:00, 1
1A03:02	SubIndex 002	2. PDO Mapping entry (object 0x6010 (ENC Inputs Ch.2), entry 0x02 (Latch extern valid))	UINT32	RO	0x6010:02, 1
1A03:03	SubIndex 003	3. PDO Mapping entry (object 0x6010 (ENC Inputs Ch.2), entry 0x03 (Set counter done))	UINT32	RO	0x6010:03, 1
1A03:04	SubIndex 004	4. PDO Mapping entry (object 0x6010 (ENC Inputs Ch.2), entry 0x04 (Counter underflow))	UINT32	RO	0x6010:04, 1
1A03:05	SubIndex 005	5. PDO Mapping entry (object 0x6010 (ENC Inputs Ch.2), entry 0x05 (Counter overflow))	UINT32	RO	0x6010:05, 1
1A03:06	SubIndex 006	6. PDO Mapping entry (2 bits align)	UINT32	RO	0x0000:00, 2
1A03:07	SubIndex 007	7. PDO Mapping entry (object 0x6010 (ENC Inputs Ch.2), entry 0x08 (Extrapolation stall))	UINT32	RO	0x6010:08, 1
1A03:08	SubIndex 008	8. PDO Mapping entry (object 0x6010 (ENC Inputs Ch.2), entry 0x09 (Status of input A))	UINT32	RO	0x6010:09, 1
1A03:09	SubIndex 009	9. PDO Mapping entry (object 0x6010 (ENC Inputs Ch.2), entry 0x0A (Status of input B))	UINT32	RO	0x6010:0A, 1
1A03:0A	SubIndex 010	10. PDO Mapping entry (1 bit align)	UINT32	RO	0x0000:00, 1
1A03:0B	SubIndex 011	11. PDO Mapping entry (1 bit align)	UINT32	RO	0x0000:00, 1
1A03:0C	SubIndex 012	12. PDO Mapping entry (object 0x6010 (ENC Inputs Ch.2), entry 0x0D (Status of extern latch))	UINT32	RO	0x6010:0D, 1
1A03:0D	SubIndex 013	13. PDO Mapping entry (object 0x1C32 (SM output parameter), entry 0x20 (Sync error))	UINT32	RO	0x1C32:20, 1
1A03:0E	SubIndex 014	14. PDO Mapping entry (1 bit align)	UINT32	RO	0x0000:00, 1
1A03:0F	SubIndex 015	15. PDO Mapping entry (object 0x1803 (ENC TxPDO-Par Status compact Ch.2), entry 0x09 (TxPDO Toggle))	UINT32	RO	0x1803:09, 1
1A03:10	SubIndex 016	16. PDO Mapping entry (object 0x6010 (ENC Inputs Ch.2), entry 0x11 (Counter value))	UINT32	RO	0x6010:11, 16
1A03:11	SubIndex 017	17. PDO Mapping entry (object 0x6010 (ENC Inputs Ch.2), entry 0x12 (Latch value))	UINT32	RO	0x6010:12, 16

Index 1A04 ENC TxPDO-Map Status Ch.2

Index (hex)	Name	Meaning	Data type	Flags	Default
1A04:0	ENC TxPDO-Map Status Ch.2	PDO Mapping TxPDO 5	UINT8	RO	0x11 (17 _{dec})
1A04:01	SubIndex 001	1. PDO Mapping entry (1 bit align)	UINT32	RO	0x0000:00, 1
1A04:02	SubIndex 002	2. PDO Mapping entry (object 0x6010 (ENC Inputs Ch.2), entry 0x02 (Latch extern valid))	UINT32	RO	0x6010:02, 1
1A04:03	SubIndex 003	3. PDO Mapping entry (object 0x6010 (ENC Inputs Ch.2), entry 0x03 (Set counter done))	UINT32	RO	0x6010:03, 1
1A04:04	SubIndex 004	4. PDO Mapping entry (object 0x6010 (ENC Inputs Ch.2), entry 0x04 (Counter underflow))	UINT32	RO	0x6010:04, 1
1A04:05	SubIndex 005	5. PDO Mapping entry (object 0x6010 (ENC Inputs Ch.2), entry 0x05 (Counter overflow))	UINT32	RO	0x6010:05, 1
1A04:06	SubIndex 006	6. PDO Mapping entry (2 bits align)	UINT32	RO	0x0000:00, 2
1A04:07	SubIndex 007	7. PDO Mapping entry (object 0x6010 (ENC Inputs Ch.2), entry 0x08 (Extrapolation stall))	UINT32	RO	0x6010:08, 1
1A04:08	SubIndex 008	8. PDO Mapping entry (object 0x6010 (ENC Inputs Ch.2), entry 0x09 (Status of input A))	UINT32	RO	0x6010:09, 1
1A04:09	SubIndex 009	9. PDO Mapping entry (object 0x6010 (ENC Inputs Ch.2), entry 0x0A (Status of input B))	UINT32	RO	0x6010:0A, 1
1A04:0A	SubIndex 010	10. PDO Mapping entry (1 bit align)	UINT32	RO	0x0000:00, 1
1A04:0B	SubIndex 011	11. PDO Mapping entry (1 bit align)	UINT32	RO	0x0000:00, 1
1A04:0C	SubIndex 012	12. PDO Mapping entry (object 0x6010 (ENC Inputs Ch.2), entry 0x0D (Status of extern latch))	UINT32	RO	0x6010:0D, 1
1A04:0D	SubIndex 013	13. PDO Mapping entry (object 0x1C32 (SM output parameter), entry 0x20 (Sync error))	UINT32	RO	0x1C32:20, 1
1A04:0E	SubIndex 014	14. PDO Mapping entry (1 bit align)	UINT32	RO	0x0000:00, 1
1A04:0F	SubIndex 015	15. PDO Mapping entry (object 0x1804 (ENC TxPDO-Par Status Ch.2), entry 0x09 (TxPDO Toggle))	UINT32	RO	0x1804:09, 1
1A04:10	SubIndex 016	16. PDO Mapping entry (object 0x6010 (ENC Inputs Ch.2), entry 0x11 (Counter value))	UINT32	RO	0x6010:11, 32
1A04:11	SubIndex 017	17. PDO Mapping entry (object 0x6010 (ENC Inputs Ch.2), entry 0x12 (Latch value))	UINT32	RO	0x6010:12, 32

Index 1A05 ENC TxPDO-Map Timest. compact Ch.2

Index (hex)	Name	Meaning	Data type	Flags	Default
1A05:0	ENC TxPDO-Map Timest. compact Ch.2	PDO Mapping TxPDO 6	UINT8	RO	0x01 (1 _{dec})
1A05:01	SubIndex 001	1. PDO Mapping entry (object 0x6010 (ENC Inputs Ch.2), entry 0x16 (Timestamp))	UINT32	RO	0x6010:16, 32

Index 1A06 DCM TxPDO-Map Status Ch.1

Index (hex)	Name	Meaning	Data type	Flags	Default
1A06:0	DCM TxPDO-Map Status Ch.1	PDO Mapping TxPDO 7	UINT8	RO	0x0E (14 _{dec})
1A06:01	SubIndex 001	1. PDO Mapping entry (object 0x6020 (DCM Inputs Ch.1), entry 0x01 (Ready to enable))	UINT32	RO	0x6020:01, 1
1A06:02	SubIndex 002	2. PDO Mapping entry (object 0x6020 (DCM Inputs Ch.1), entry 0x02 (Ready))	UINT32	RO	0x6020:02, 1
1A06:03	SubIndex 003	3. PDO Mapping entry (object 0x6020 (DCM Inputs Ch.1), entry 0x03 (Warning))	UINT32	RO	0x6020:03, 1
1A06:04	SubIndex 004	4. PDO Mapping entry (object 0x6020 (DCM Inputs Ch.1), entry 0x04 (Error))	UINT32	RO	0x6020:04, 1
1A06:05	SubIndex 005	5. PDO Mapping entry (object 0x6020 (DCM Inputs Ch.1), entry 0x05 (Moving positive))	UINT32	RO	0x6020:05, 1
1A06:06	SubIndex 006	6. PDO Mapping entry (object 0x6020 (DCM Inputs Ch.1), entry 0x06 (Moving negative))	UINT32	RO	0x6020:06, 1
1A06:07	SubIndex 007	7. PDO Mapping entry (object 0x6020 (DCM Inputs Ch.1), entry 0x07 (Torque reduced))	UINT32	RO	0x6020:07, 1
1A06:08	SubIndex 008	8. PDO Mapping entry (1 bit align)	UINT32	RO	0x0000:00, 1
1A06:09	SubIndex 009	9. PDO Mapping entry (3 bits align)	UINT32	RO	0x0000:00, 3
1A06:0A	SubIndex 010	10. PDO Mapping entry (object 0x6020 (DCM Inputs Ch.1), entry 0x0C (Digital input 1))	UINT32	RO	0x6020:0C, 1
1A06:0B	SubIndex 011	11. PDO Mapping entry (object 0x6020 (DCM Inputs Ch.1), entry 0x0D (Digital input 2))	UINT32	RO	0x6020:0D, 1
1A06:0C	SubIndex 012	12. PDO Mapping entry (object 0x1C32 (SM output parameter), entry 0x20 (Sync error))	UINT32	RO	0x1C32:20, 1
1A06:0D	SubIndex 013	13. PDO Mapping entry (1 bit align)	UINT32	RO	0x0000:00, 1
1A06:0E	SubIndex 014	14. PDO Mapping entry (object 0x1806, entry 0x09)	UINT32	RO	0x1806:09, 1

Index 1A07 DCM TxPDO-Map Synchron info data Ch.1

Index (hex)	Name	Meaning	Data type	Flags	Default
1A07:0	DCM TxPDO-Map Synchron info data Ch.1	PDO Mapping TxPDO 8	UINT8	RO	0x02 (2 _{dec})
1A07:01	SubIndex 001	1. PDO Mapping entry (object 0x6020 (DCM Inputs Ch.1), entry 0x11 (Info data 1))	UINT32	RO	0x6020:11, 16
1A07:02	SubIndex 002	2. PDO Mapping entry (object 0x6020 (DCM Inputs Ch.1), entry 0x12 (Info data 2))	UINT32	RO	0x6020:12, 16

Index 1A08 DCM TxPDO-Map Status Ch.2

Index (hex)	Name	Meaning	Data type	Flags	Default
1A08:0	DCM TxPDO-Map Status Ch.2	PDO Mapping TxPDO 9	UINT8	RO	0x0E (14 _{dec})
1A08:01	SubIndex 001	1. PDO Mapping entry (object 0x6030 (DCM Inputs Ch.2), entry 0x01 (Ready to enable))	UINT32	RO	0x6030:01, 1
1A08:02	SubIndex 002	2. PDO Mapping entry (object 0x6030 (DCM Inputs Ch.2), entry 0x02 (Ready))	UINT32	RO	0x6030:02, 1
1A08:03	SubIndex 003	3. PDO Mapping entry (object 0x6030 (DCM Inputs Ch.2), entry 0x03 (Warning))	UINT32	RO	0x6030:03, 1
1A08:04	SubIndex 004	4. PDO Mapping entry (object 0x6030 (DCM Inputs Ch.2), entry 0x04 (Error))	UINT32	RO	0x6030:04, 1
1A08:05	SubIndex 005	5. PDO Mapping entry (object 0x6030 (DCM Inputs Ch.2), entry 0x05 (Moving positive))	UINT32	RO	0x6030:05, 1
1A08:06	SubIndex 006	6. PDO Mapping entry (object 0x6030 (DCM Inputs Ch.2), entry 0x06 (Moving negative))	UINT32	RO	0x6030:06, 1
1A08:07	SubIndex 007	7. PDO Mapping entry (object 0x6030 (DCM Inputs Ch.2), entry 0x07 (Torque reduced))	UINT32	RO	0x6030:07, 1
1A08:08	SubIndex 008	8. PDO Mapping entry (1 bit align)	UINT32	RO	0x0000:00, 1
1A08:09	SubIndex 009	9. PDO Mapping entry (3 bits align)	UINT32	RO	0x0000:00, 3
1A08:0A	SubIndex 010	10. PDO Mapping entry (object 0x6030 (DCM Inputs Ch.2), entry 0x0C (Digital input 1))	UINT32	RO	0x6030:0C, 1
1A08:0B	SubIndex 011	11. PDO Mapping entry (object 0x6030 (DCM Inputs Ch.2), entry 0x0D (Digital input 2))	UINT32	RO	0x6030:0D, 1
1A08:0C	SubIndex 012	12. PDO Mapping entry (object 0x1C32 (SM output parameter), entry 0x20 (Sync error))	UINT32	RO	0x1C32:20, 1
1A08:0D	SubIndex 013	13. PDO Mapping entry (1 bit align)	UINT32	RO	0x0000:00, 1
1A08:0E	SubIndex 014	14. PDO Mapping entry (object 0x1808, entry 0x09)	UINT32	RO	0x1808:09, 1

Index 1A09 DCM TxPDO-Map Synchron info data Ch.2

Index (hex)	Name	Meaning	Data type	Flags	Default
1A09:0	DCM TxPDO-Map Synchron info data Ch.2	PDO Mapping TxPDO 10	UINT8	RO	0x02 (2 _{dec})
1A09:01	SubIndex 001	1. PDO Mapping entry (object 0x6030 (DCM Inputs Ch.2), entry 0x11 (Info data 1))	UINT32	RO	0x6030:11, 16
1A09:02	SubIndex 002	2. PDO Mapping entry (object 0x6030 (DCM Inputs Ch.2), entry 0x12 (Info data 2))	UINT32	RO	0x6030:12, 16

Index 1A0A POS TxPDO-Map Status compact Ch.1

Index (hex)	Name	Meaning	Data type	Flags	Default
1A0A:0	POS TxPDO-Map Status compact Ch.1	PDO Mapping TxPDO 11	UINT8	RO	0x09 (9 _{dec})
1A0A:01	SubIndex 001	1. PDO Mapping entry (object 0x6040 (POS Inputs Ch.1), entry 0x01 (Busy))	UINT32	RO	0x6040:01, 1
1A0A:02	SubIndex 002	2. PDO Mapping entry (object 0x6040 (POS Inputs Ch.1), entry 0x02 (In-Target))	UINT32	RO	0x6040:02, 1
1A0A:03	SubIndex 003	3. PDO Mapping entry (object 0x6040 (POS Inputs Ch.1), entry 0x03 (Warning))	UINT32	RO	0x6040:03, 1
1A0A:04	SubIndex 004	4. PDO Mapping entry (object 0x6040 (POS Inputs Ch.1), entry 0x04 (Error))	UINT32	RO	0x6040:04, 1
1A0A:05	SubIndex 005	5. PDO Mapping entry (object 0x6040 (POS Inputs Ch.1), entry 0x05 (Calibrated))	UINT32	RO	0x6040:05, 1
1A0A:06	SubIndex 006	6. PDO Mapping entry (object 0x6040 (POS Inputs Ch.1), entry 0x06 (Accelerate))	UINT32	RO	0x6040:06, 1
1A0A:07	SubIndex 007	7. PDO Mapping entry (object 0x6040 (POS Inputs Ch.1), entry 0x07 (Decelerate))	UINT32	RO	0x6040:07, 1
1A0A:08	SubIndex 008	8. PDO Mapping entry (1 bit align)	UINT32	RO	0x0000:00, 1
1A0A:09	SubIndex 009	9. PDO Mapping entry (8 bits align)	UINT32	RO	0x0000:00, 8

Index 1A0B POS TxPDO-Map Status Ch.1

Index (hex)	Name	Meaning	Data type	Flags	Default
1A0B:0	POS TxPDO-Map Status Ch.1	PDO Mapping TxPDO 12	UINT8	RO	0x0C (12 _{dec})
1A0B:01	SubIndex 001	1. PDO Mapping entry (object 0x6040 (POS Inputs Ch.1), entry 0x01 (Busy))	UINT32	RO	0x6040:01, 1
1A0B:02	SubIndex 002	2. PDO Mapping entry (object 0x6040 (POS Inputs Ch.1), entry 0x02 (In-Target))	UINT32	RO	0x6040:02, 1
1A0B:03	SubIndex 003	3. PDO Mapping entry (object 0x6040 (POS Inputs Ch.1), entry 0x03 (Warning))	UINT32	RO	0x6040:03, 1
1A0B:04	SubIndex 004	4. PDO Mapping entry (object 0x6040 (POS Inputs Ch.1), entry 0x04 (Error))	UINT32	RO	0x6040:04, 1
1A0B:05	SubIndex 005	5. PDO Mapping entry (object 0x6040 (POS Inputs Ch.1), entry 0x05 (Calibrated))	UINT32	RO	0x6040:05, 1
1A0B:06	SubIndex 006	6. PDO Mapping entry (object 0x6040 (POS Inputs Ch.1), entry 0x06 (Accelerate))	UINT32	RO	0x6040:06, 1
1A0B:07	SubIndex 007	7. PDO Mapping entry (object 0x6040 (POS Inputs Ch.1), entry 0x07 (Decelerate))	UINT32	RO	0x6040:07, 1
1A0B:08	SubIndex 008	8. PDO Mapping entry (1 bit align)	UINT32	RO	0x0000:00, 1
1A0B:09	SubIndex 009	9. PDO Mapping entry (8 bits align)	UINT32	RO	0x0000:00, 8
1A0B:0A	SubIndex 010	10. PDO Mapping entry (object 0x6040 (POS Inputs Ch.1), entry 0x11 (Actual position))	UINT32	RO	0x6040:11, 32
1A0B:0B	SubIndex 011	11. PDO Mapping entry (object 0x6040 (POS Inputs Ch.1), entry 0x21 (Actual velocity))	UINT32	RO	0x6040:21, 16
1A0B:0C	SubIndex 012	12. PDO Mapping entry (object 0x6040 (POS Inputs Ch.1), entry 0x22 (Actual drive time))	UINT32	RO	0x6040:22, 32

Index 1A0C POS TxPDO-Map Status compact Ch.2

Index (hex)	Name	Meaning	Data type	Flags	Default
1A0C:0	POS TxPDO-Map Status compact Ch.2	PDO Mapping TxPDO 13	UINT8	RO	0x09 (9 _{dec})
1A0C:01	SubIndex 001	1. PDO Mapping entry (object 0x6050 (POS Inputs Ch.2), entry 0x01 (Busy))	UINT32	RO	0x6050:01, 1
1A0C:02	SubIndex 002	2. PDO Mapping entry (object 0x6050 (POS Inputs Ch.2), entry 0x02 (In-Target))	UINT32	RO	0x6050:02, 1
1A0C:03	SubIndex 003	3. PDO Mapping entry (object 0x6050 (POS Inputs Ch.2), entry 0x03 (Warning))	UINT32	RO	0x6050:03, 1
1A0C:04	SubIndex 004	4. PDO Mapping entry (object 0x6050 (POS Inputs Ch.2), entry 0x04 (Error))	UINT32	RO	0x6050:04, 1
1A0C:05	SubIndex 005	5. PDO Mapping entry (object 0x6050 (POS Inputs Ch.2), entry 0x05 (Calibrated))	UINT32	RO	0x6050:05, 1
1A0C:06	SubIndex 006	6. PDO Mapping entry (object 0x6050 (POS Inputs Ch.2), entry 0x06 (Accelerate))	UINT32	RO	0x6050:06, 1
1A0C:07	SubIndex 007	7. PDO Mapping entry (object 0x6050 (POS Inputs Ch.2), entry 0x07 (Decelerate))	UINT32	RO	0x6050:07, 1
1A0C:08	SubIndex 008	8. PDO Mapping entry (1 bit align)	UINT32	RO	0x0000:00, 1
1A0C:09	SubIndex 009	9. PDO Mapping entry (8 bits align)	UINT32	RO	0x0000:00, 8

Index 1A0D POS TxPDO-Map Status Ch.2

Index (hex)	Name	Meaning	Data type	Flags	Default
1A0D:0	POS TxPDO-Map Status Ch.2	PDO Mapping TxPDO 14	UINT8	RO	0x0C (12 _{dec})
1A0D:01	SubIndex 001	1. PDO Mapping entry (object 0x6050 (POS Inputs Ch.2), entry 0x01 (Busy))	UINT32	RO	0x6050:01, 1
1A0D:02	SubIndex 002	2. PDO Mapping entry (object 0x6050 (POS Inputs Ch.2), entry 0x02 (In-Target))	UINT32	RO	0x6050:02, 1
1A0D:03	SubIndex 003	3. PDO Mapping entry (object 0x6050 (POS Inputs Ch.2), entry 0x03 (Warning))	UINT32	RO	0x6050:03, 1
1A0D:04	SubIndex 004	4. PDO Mapping entry (object 0x6050 (POS Inputs Ch.2), entry 0x04 (Error))	UINT32	RO	0x6050:04, 1
1A0D:05	SubIndex 005	5. PDO Mapping entry (object 0x6050 (POS Inputs Ch.2), entry 0x05 (Calibrated))	UINT32	RO	0x6050:05, 1
1A0D:06	SubIndex 006	6. PDO Mapping entry (object 0x6050 (POS Inputs Ch.2), entry 0x06 (Accelerate))	UINT32	RO	0x6050:06, 1
1A0D:07	SubIndex 007	7. PDO Mapping entry (object 0x6050 (POS Inputs Ch.2), entry 0x07 (Decelerate))	UINT32	RO	0x6050:07, 1
1A0D:08	SubIndex 008	8. PDO Mapping entry (1 bit align)	UINT32	RO	0x0000:00, 1
1A0D:09	SubIndex 009	9. PDO Mapping entry (8 bits align)	UINT32	RO	0x0000:00, 8
1A0D:0A	SubIndex 010	10. PDO Mapping entry (object 0x6050 (POS Inputs Ch.2), entry 0x11 (Actual position))	UINT32	RO	0x6050:11, 32
1A0D:0B	SubIndex 011	11. PDO Mapping entry (object 0x6050 (POS Inputs Ch.2), entry 0x21 (Actual velocity))	UINT32	RO	0x6050:21, 16
1A0D:0C	SubIndex 012	12. PDO Mapping entry (object 0x6050 (POS Inputs Ch.2), entry 0x22 (Actual drive time))	UINT32	RO	0x6050:22, 32

Index 1C00 Sync manager type

Index (hex)	Name	Meaning	Data type	Flags	Default
1C00:0	Sync manager type	Using the sync managers	UINT8	RO	0x04 (4 _{dec})
1C00:01	SubIndex 001	Sync-Manager Type Channel 1: Mailbox Write	UINT8	RO	0x01 (1 _{dec})
1C00:02	SubIndex 002	Sync-Manager Type Channel 2: Mailbox Read	UINT8	RO	0x02 (2 _{dec})
1C00:03	SubIndex 003	Sync-Manager Type Channel 3: Process Data Write (Outputs)	UINT8	RO	0x03 (3 _{dec})
1C00:04	SubIndex 004	Sync-Manager Type Channel 4: Process Data Read (Inputs)	UINT8	RO	0x04 (4 _{dec})

Index 1C12 RxPDO assign

Index (hex)	Name	Meaning	Data type	Flags	Default
1C12:0	RxPDO assign	PDO Assign Outputs	UINT8	RW	0x06 (6 _{dec})
1C12:01	SubIndex 001	1. allocated RxPDO (contains the index of the associated RxPDO mapping object)	UINT16	RW	0x1600 (5632 _{dec})
1C12:02	SubIndex 002	2. allocated RxPDO (contains the index of the associated RxPDO mapping object)	UINT16	RW	0x1602 (5634 _{dec})
1C12:03	SubIndex 003	3. allocated RxPDO (contains the index of the associated RxPDO mapping object)	UINT16	RW	0x1604 (5636 _{dec})
1C12:04	SubIndex 004	4. allocated RxPDO (contains the index of the associated RxPDO mapping object)	UINT16	RW	0x1606 (5638 _{dec})
1C12:05	SubIndex 005	5. allocated RxPDO (contains the index of the associated RxPDO mapping object)	UINT16	RW	0x1607 (5639 _{dec})
1C12:06	SubIndex 006	6. allocated RxPDO (contains the index of the associated RxPDO mapping object)	UINT16	RW	0x1609 (5641 _{dec})

Index 1C13 TxPDO assign

Index (hex)	Name	Meaning	Data type	Flags	Default
1C13:0	TxPDO assign	PDO Assign Inputs	UINT8	RW	0x04 (4 _{dec})
1C13:01	SubIndex 001	1. allocated TxPDO (contains the index of the associated TxPDO mapping object)	UINT16	RW	0x1A00 (6656 _{dec})
1C13:02	SubIndex 002	2. allocated TxPDO (contains the index of the associated TxPDO mapping object)	UINT16	RW	0x1A03 (6659 _{dec})
1C13:03	SubIndex 003	3. allocated TxPDO (contains the index of the associated TxPDO mapping object)	UINT16	RW	0x1A06 (6662 _{dec})
1C13:04	SubIndex 004	4. allocated TxPDO (contains the index of the associated TxPDO mapping object)	UINT16	RW	0x1A08 (6664 _{dec})
1C13:05	SubIndex 005	5. allocated TxPDO (contains the index of the associated TxPDO mapping object)	UINT16	RW	0x0000 (0 _{dec})
1C32:06	SubIndex 006	6. allocated TxPDO (contains the index of the associated TxPDO mapping object)	UINT16	RW	0x0000 (0 _{dec})
1C13:07	SubIndex 007	7. allocated TxPDO (contains the index of the associated TxPDO mapping object)	UINT16	RW	0x0000 (0 _{dec})
1C13:08	SubIndex 008	8. allocated TxPDO (contains the index of the associated TxPDO mapping object)	UINT16	RW	0x0000 (0 _{dec})
1C13:09	SubIndex 009	9. allocated TxPDO (contains the index of the associated TxPDO mapping object)	UINT16	RW	0x0000 (0 _{dec})
1C13:0A	SubIndex 010	10. allocated TxPDO (contains the index of the associated TxPDO mapping object)	UINT16	RW	0x0000 (0 _{dec})

Index 1C32 SM output parameter

Index (hex)	Name	Meaning	Data type	Flags	Default
1C32:0	SM output parameter	Synchronization parameters for the outputs	UINT8	RO	0x20 (32 _{dec})
1C32:01	Sync mode	Current synchronization mode: <ul style="list-style-type: none"> 0: Free Run 1: Synchronous with SM 2 event 2: DC-Mode - Synchronous with SYNC0 Event 3: DC-Mode - Synchronous with SYNC1 event 	UINT16	RW	0x0001 (1 _{dec})
1C32:02	Cycle time	Cycle time (in ns): <ul style="list-style-type: none"> Free Run: Cycle time of the local timer Synchron with SM 2 Event: Master cycle time DC mode: SYNC0/SYNC1 Cycle Time 	UINT32	RW	0x000F4240 (1000000 _{dec})
1C32:03	Shift time	Time between SYNC0 event and output of the outputs (in ns, DC mode only)	UINT32	RO	0x00000000 (0 _{dec})
1C32:04	Sync modes supported	Supported synchronization modes: <ul style="list-style-type: none"> Bit 0 = 1: free run is supported Bit 1 = 1: Synchron with SM 2 event is supported Bit 2-3 = 01: DC mode is supported Bit 4-5 = 10: Output shift with SYNC1 event (only DC mode) Bit 14 = 1: dynamic times (measurement through writing of 1C32:08) 	UINT16	RO	0xC007 (49159 _{dec})
1C32:05	Minimum cycle time	Minimum cycle time (in ns)	UINT32	RO	0x0003D090 (250000 _{dec})
1C32:06	Calc and copy time	Minimum time between SYNC0 and SYNC1 event (in ns, DC mode only)	UINT32	RO	0x00000000 (0 _{dec})
1C32:07	Minimum delay time		UINT32	RO	0x00000000 (0 _{dec})
1C32:08	Command	<ul style="list-style-type: none"> 0: Measurement of the local cycle time is stopped 1: Measurement of the local cycle time is started <p>The entries 0x1C32:03, 0x1C32:05, 0x1C32:06, 0x1C32:09, 0x1C33:03 [▶ 85], 0x1C33:06, 0x1C33:09 [▶ 85] are updated with the maximum measured values. For a subsequent measurement the measured values are reset</p>	UINT16	RW	0x0000 (0 _{dec})
1C32:09	Maximum delay time	Time between SYNC1 event and output of the outputs (in ns, DC mode only)	UINT32	RO	0x00000000 (0 _{dec})
1C32:0B	SM event missed counter	Number of missed SM events in OPERATIONAL (DC mode only)	UINT16	RO	0x0000 (0 _{dec})
1C32:0C	Cycle exceeded counter	Number of occasions the cycle time was exceeded in OPERATIONAL (cycle was not completed in time or the next cycle began too early)	UINT16	RO	0x0000 (0 _{dec})
1C32:0D	Shift too short counter	Number of occasions that the interval between SYNC0 and SYNC1 event was too short (DC mode only)	UINT16	RO	0x0000 (0 _{dec})
1C32:20	Sync error	The synchronization was not correct in the last cycle (outputs were output too late; DC mode only)	BOOLEAN	RO	0x00 (0 _{dec})

Index 1C33 SM input parameter

Index (hex)	Name	Meaning	Data type	Flags	Default
1C33:0	SM input parameter	Synchronization parameters for the inputs	UINT8	RO	0x20 (32 _{dec})
1C33:01	Sync mode	Current synchronization mode: <ul style="list-style-type: none"> • 0: Free Run • 1: Synchron with SM 3 Event (no outputs available) • 2: DC - Synchron with SYNC0 Event • 3: DC - Synchron with SYNC1 Event • 34: Synchron with SM 2 Event (outputs available) 	UINT16	RW	0x0022 (34 _{dec})
1C33:02	Cycle time	as 0x1C32:02 [▶ 84]	UINT32	RW	0x000F4240 (1000000 _{dec})
1C33:03	Shift time	Time between SYNC0 event and reading of the inputs (in ns, only DC mode)	UINT32	RO	0x00000000 (0 _{dec})
1C33:04	Sync modes supported	Supported synchronization modes: <ul style="list-style-type: none"> • Bit 0: free run is supported • Bit 1: Synchronous with SM 2 Event is supported (outputs available) • Bit 1: Synchronous with SM 3 Event is supported (no outputs available) • Bit 2-3 = 01: DC mode is supported • Bit 4-5 = 01: input shift through local event (outputs available) • Bit 4-5 = 10: input shift with SYNC1 event (no outputs available) • Bit 14 = 1: dynamic times (measurement through writing of 0x1C32:08 [▶ 84] or 0x1C33:08) 	UINT16	RO	0xC007 (49159 _{dec})
1C33:05	Minimum cycle time	as 0x1C32:05 [▶ 84]	UINT32	RO	0x0003D090 (250000 _{dec})
1C33:06	Calc and copy time	Time between reading of the inputs and availability of the inputs for the master (in ns, only DC mode)	UINT32	RO	0x00000000 (0 _{dec})
1C33:07	Minimum delay time		UINT32	RO	0x00000000 (0 _{dec})
1C33:08	Command	as 1C32:08 [▶ 84]	UINT16	RW	0x0000 (0 _{dec})
1C33:09	Maximum delay time	Time between SYNC1 event and reading of the inputs (in ns, only DC mode)	UINT32	RO	0x00000000 (0 _{dec})
1C33:0B	SM event missed counter	as 0x1C32:11 [▶ 84]	UINT16	RO	0x0000 (0 _{dec})
1C33:0C	Cycle exceeded counter	as 0x1C32:12 [▶ 84]	UINT16	RO	0x0000 (0 _{dec})
1C33:0D	Shift too short counter	as 0x1C32:13 [▶ 84]	UINT16	RO	0x0000 (0 _{dec})
1C33:20	Sync error	as 0x1C32:32 [▶ 84]	BOOLEAN	RO	0x00 (0 _{dec})

Index F000 Modular device profile

Index (hex)	Name	Meaning	Data type	Flags	Default
F000:0	Modular device profile	General information for the modular device profile	UINT8	RO	0x02 (2 _{dec})
F000:01	Module index distance	Index distance of the objects of the individual channels	UINT16	RO	0x0010 (16 _{dec})
F000:02	Maximum number of modules	Number of channels	UINT16	RO	0x0006 (6 _{dec})

Index F008 Code word

Index (hex)	Name	Meaning	Data type	Flags	Default
F008:0	Code word	reserved	UINT32	RW	0x00000000 (0 _{dec})

Index F010 Module list

Index (hex)	Name	Meaning	Data type	Flags	Default
F010:0	Module list	Max. Subindex	UINT8	RW	0x06 (6 _{dec})
F010:01	SubIndex 001	Profile number of the encoder interface	UINT32	RW	0x000001FF (511 _{dec})
F010:02	SubIndex 002	Profile number of the encoder interface	UINT32	RW	0x000001FF (511 _{dec})
F010:03	SubIndex 003	Profile number of the DC motor interface	UINT32	RW	0x000002DD (733 _{dec})
F010:04	SubIndex 004	Profile number of the DC motor interface	UINT32	RW	0x000002DD (733 _{dec})
F010:05	SubIndex 005	Profile number of the positioning interface	UINT32	RW	0x000002C0 (704 _{dec})
F010:06	SubIndex 006	Profile number of the positioning interface	UINT32	RW	0x000002C0 (704 _{dec})

7 Appendix

7.1 General operating conditions

Protection rating according to IP code

The degrees of protection are defined and divided into different classes in the IEC 60529 standard (EN 60529). Degrees of protection are designated by the letters "IP" and two numerals: **IPxy**

- Numeral x: Dust protection and contact protection
- Numeral y: Protection against water

x	Meaning
0	Not protected
1	Protected against access to dangerous parts with the back of the hand. Protected against solid foreign objects of 50 mm Ø
2	Protected against access to dangerous parts with a finger. Protected against solid foreign objects of 12.5 mm Ø
3	Protected against access to dangerous parts with a tool. Protected against solid foreign objects of 2.5 mm Ø
4	Protected against access to dangerous parts with a wire. Protected against solid foreign objects of 1 mm Ø
5	Protection against access to dangerous parts with a wire. Dust-protected. Ingress of dust is not prevented completely, although the quantity of dust able to penetrate is limited to such an extent that the proper function of the device and safety are not impaired
6	Protection against access to dangerous parts with a wire. Dust-tight. No ingress of dust

y	Meaning
0	Not protected
1	Protection against vertically falling water drops
2	Protection against vertically falling water drops when enclosure tilted up to 15°
3	Protection against spraying water. Water sprayed at an angle of up to 60° on either side of the vertical shall have no harmful effects
4	Protection against splashing water. Water splashed against the enclosure from any direction shall have no harmful effects
5	Protection against water jets.
6	Protection against powerful water jets.
7	Protected against the effects of temporary immersion in water. Ingress of water in quantities causing harmful effects shall not be possible when the enclosure is immersed in water at a depth of 1 m for 30 minutes

Chemical resistance

The resistance refers to the housing of the IP67 modules and the metal parts used. In the table below you will find some typical resistances.

Type	Resistance
Water vapor	unstable at temperatures > 100 °C
Sodium hydroxide solution (ph value > 12)	stable at room temperature unstable > 40 °C
Acetic acid	unstable
Argon (technically pure)	stable

Key

- resistant: Lifetime several months
- non inherently resistant: Lifetime several weeks
- not resistant: Lifetime several hours resp. early decomposition

7.2 Accessories

Mounting

Ordering information	Description	Link
ZS5300-0011	Mounting rail	Website

Cables

A complete overview of pre-assembled cables for fieldbus components can be found [here](#).

Ordering information	Description	Link
ZK4000-51xx-xxxx	Encoder cable, shielded	Website
ZK4000-6xxx-xxxx	Motor cable	Website
ZK700x-xxxx-xxxx	EtherCAT P cable M8	Website

Labeling material, protective caps

Ordering information	Description
ZS5000-0010	Protective cap for M8 sockets, IP67 (50 pieces)
ZS5000-0020	Protective cap for M12 sockets, IP67 (50 pcs.)
ZS5100-0000	Inscription labels, unprinted, 4 strips of 10
ZS5000-xxxx	Printed inscription labels on enquiry

Tools

Ordering information	Description
ZB8801-0000	Torque wrench for plugs, 0.4...1.0 Nm
ZB8801-0001	Torque cable key for M8 / wrench size 9 for ZB8801-0000
ZB8801-0002	Torque cable key for M12 / wrench size 13 for ZB8801-0000
ZB8801-0003	Torque cable key for M12 field assembly / wrench size 18 for ZB8801-0000



Further accessories

Further accessories can be found in the price list for fieldbus components from Beckhoff and online at <https://www.beckhoff.com>.

7.3 Version identification of EtherCAT devices

7.3.1 General notes on marking

Designation

A Beckhoff EtherCAT device has a 14-digit designation, made up of

- family key
- type
- version
- revision

Example	Family	Type	Version	Revision
EL3314-0000-0016	EL terminal 12 mm, non-pluggable connection level	3314 4-channel thermocouple terminal	0000 basic type	0016
ES3602-0010-0017	ES terminal 12 mm, pluggable connection level	3602 2-channel voltage measurement	0010 high-precision version	0017
CU2008-0000-0000	CU device	2008 8-port fast ethernet switch	0000 basic type	0000

Notes

- The elements mentioned above result in the **technical designation**. EL3314-0000-0016 is used in the example below.
- EL3314-0000 is the order identifier, in the case of "-0000" usually abbreviated to EL3314. "-0016" is the EtherCAT revision.
- The **order identifier** is made up of
 - family key (EL, EP, CU, ES, KL, CX, etc.)
 - type (3314)
 - version (-0000)
- The **revision** -0016 shows the technical progress, such as the extension of features with regard to the EtherCAT communication, and is managed by Beckhoff.
In principle, a device with a higher revision can replace a device with a lower revision, unless specified otherwise, e.g. in the documentation.
Associated and synonymous with each revision there is usually a description (ESI, EtherCAT Slave Information) in the form of an XML file, which is available for download from the Beckhoff web site.
From 2014/01 the revision is shown on the outside of the IP20 terminals, see Fig. "EL5021 EL terminal, standard IP20 IO device with batch number and revision ID (since 2014/01)".
- The type, version and revision are read as decimal numbers, even if they are technically saved in hexadecimal.

7.3.2 Version identification of IP67 modules

The serial number/ data code for Beckhoff IO devices is usually the 8-digit number printed on the device or on a sticker. The serial number indicates the configuration in delivery state and therefore refers to a whole production batch, without distinguishing the individual modules of a batch.

Structure of the serial number: **KK YY FF HH**

KK - week of production (CW, calendar week)

YY - year of production

FF - firmware version

HH - hardware version

Example with serial number 12 06 3A 02:

12 - production week 12

06 - production year 2006

3A - firmware version 3A

02 - hardware version 02

Exceptions can occur in the **IP67 area**, where the following syntax can be used (see respective device documentation):

Syntax: D ww yy x y z u

D - prefix designation

ww - calendar week

yy - year

x - firmware version of the bus PCB

y - hardware version of the bus PCB

z - firmware version of the I/O PCB

u - hardware version of the I/O PCB

Example: D.22081501 calendar week 22 of the year 2008 firmware version of bus PCB: 1 hardware version of bus PCB: 5 firmware version of I/O PCB: 0 (no firmware necessary for this PCB) hardware version of I/O PCB: 1

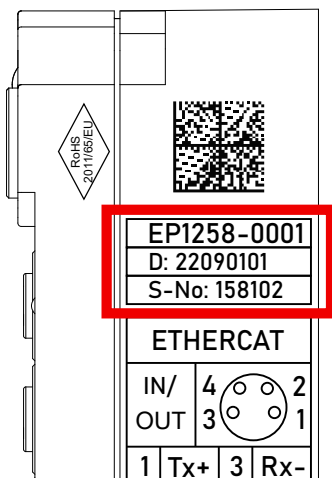

Fig. 21: EP1258-00001 IP67 EtherCAT Box with batch number/DateCode 22090101 and unique serial number 158102

7.3.3 Beckhoff Identification Code (BIC)

The Beckhoff Identification Code (BIC) is increasingly being applied to Beckhoff products to uniquely identify the product. The BIC is represented as a Data Matrix Code (DMC, code scheme ECC200), the content is based on the ANSI standard MH10.8.2-2016.

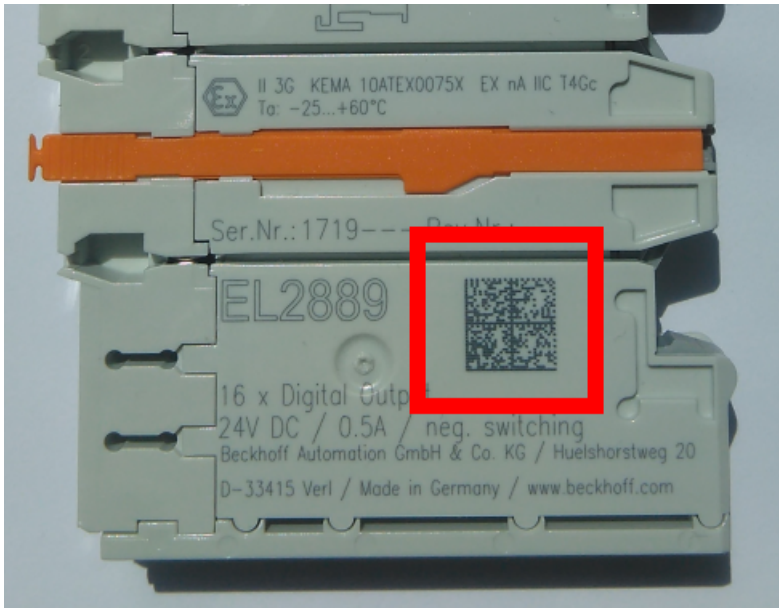

Fig. 22: BIC as data matrix code (DMC, code scheme ECC200)

The BIC will be introduced step by step across all product groups.

Depending on the product, it can be found in the following places:

- on the packaging unit
- directly on the product (if space suffices)
- on the packaging unit and the product

The BIC is machine-readable and contains information that can also be used by the customer for handling and product management.

Each piece of information can be uniquely identified using the so-called data identifier (ANSI MH10.8.2-2016). The data identifier is followed by a character string. Both together have a maximum length according to the table below. If the information is shorter, spaces are added to it.

Following information is possible, positions 1 to 4 are always present, the other according to need of production:

Position	Type of information	Explanation	Data identifier	Number of digits incl. data identifier	Example
1	Beckhoff order number	Beckhoff order number	1P	8	1P 072222
2	Beckhoff Traceability Number (BTN)	Unique serial number, see note below	SBTN	12	S BTNk4p562d7
3	Article description	Beckhoff article description, e.g. EL1008	1K	32	1K EL1809
4	Quantity	Quantity in packaging unit, e.g. 1, 10, etc.	Q	6	Q 1
5	Batch number	Optional: Year and week of production	2P	14	2P 401503180016
6	ID/serial number	Optional: Present-day serial number system, e.g. with safety products	51S	12	51S 678294
7	Variant number	Optional: Product variant number on the basis of standard products	30P	32	30P F971, 2*K183
...					

Further types of information and data identifiers are used by Beckhoff and serve internal processes.

Structure of the BIC

Example of composite information from positions 1 to 4 and with the above given example value on position 6. The data identifiers are highlighted in bold font:

1P072222**S**BTNk4p562d7**1K**EL1809 **Q**1 **51S**678294

Accordingly as DMC:



Fig. 23: Example DMC **1P**072222**S**BTNk4p562d7**1K**EL1809 **Q**1 **51S**678294

BTN

An important component of the BIC is the Beckhoff Traceability Number (BTN, position 2). The BTN is a unique serial number consisting of eight characters that will replace all other serial number systems at Beckhoff in the long term (e.g. batch designations on IO components, previous serial number range for safety products, etc.). The BTN will also be introduced step by step, so it may happen that the BTN is not yet coded in the BIC.

NOTICE

This information has been carefully prepared. However, the procedure described is constantly being further developed. We reserve the right to revise and change procedures and documentation at any time and without prior notice. No claims for changes can be made from the information, illustrations and descriptions in this information.

7.3.4 Electronic access to the BIC (eBIC)

Electronic BIC (eBIC)

The Beckhoff Identification Code (BIC) is applied to the outside of Beckhoff products in a visible place. If possible, it should also be electronically readable.

Decisive for the electronic readout is the interface via which the product can be electronically addressed.

K-bus devices (IP20, IP67)

Currently, no electronic storage and readout is planned for these devices.

EtherCAT devices (IP20, IP67)

All Beckhoff EtherCAT devices have a so-called ESI-EEPROM, which contains the EtherCAT identity with the revision number. Stored in it is the EtherCAT slave information, also colloquially known as ESI/XML configuration file for the EtherCAT master. See the corresponding chapter in the EtherCAT system manual ([Link](#)) for the relationships.

The eBIC is also stored in the ESI-EEPROM. The eBIC was introduced into the Beckhoff I/O production (terminals, box modules) from 2020; widespread implementation is expected in 2021.

The user can electronically access the eBIC (if existent) as follows:

- With all EtherCAT devices, the EtherCAT master (TwinCAT) can read the eBIC from the ESI-EEPROM
 - From TwinCAT 3.1 build 4024.11, the eBIC can be displayed in the online view.
 - To do this, check the checkbox "Show Beckhoff Identification Code (BIC)" under EtherCAT → Advanced Settings → Diagnostics:

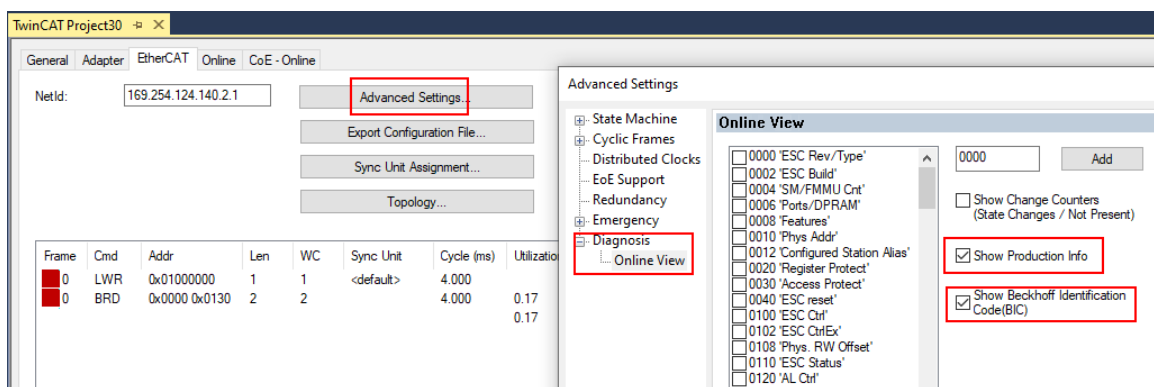

- The BTN and its contents are then displayed:

No	Addr	Name	State	CRC	Fw	Hw	Production Data	ItemNo	BTN	Description	Quantity	BatchNo	SerialNo
1	1001	Term 1 (EK1100)	OP	0.0	0	0	---						
2	1002	Term 2 (EL1018)	OP	0.0	0	0	2020 KW36 Fr	072222	k4p562d7	EL1809	1		678294
3	1003	Term 3 (EL3204)	OP	0.0	7	6	2012 KW24 Sa						
4	1004	Term 4 (EL2004)	OP	0.0	0	0	---	072223	k4p562d7	EL2004	1		678295
5	1005	Term 5 (EL1008)	OP	0.0	0	0	---						
6	1006	Term 6 (EL2008)	OP	0.0	0	12	2014 KW14 Mo						
7	1007	Term 7 (EK1110)	OP	0	1	8	2012 KW25 Mo						

- Note: as can be seen in the illustration, the production data HW version, FW version and production date, which have been programmed since 2012, can also be displayed with "Show Production Info".
- Access from the PLC: From TwinCAT 3.1. build 4024.24 the functions *FB_EcReadBIC* and *FB_EcReadBTN* are available in the Tc2_EtherCAT Library from v3.3.19.0 for reading into the PLC..
- In the case of EtherCAT devices with CoE directory, the object 0x10E2:01 can additionally be used to display the device's own eBIC; the PLC can also simply access the information here:

- The device must be in PREOP/SAFEOP/OP for access:

Index	Name	Flags	Value
1000	Device type	RO	0x015E1389 (22942601)
1008	Device name	RO	ELM3704-0000
1009	Hardware version	RO	00
100A	Software version	RO	01
100B	Bootloader version	RO	J0.1.27.0
1011:0	Restore default parameters	RO	> 1 <
1018:0	Identity	RO	> 4 <
10E2:0	Manufacturer-specific Identification C...	RO	> 1 <
10E2:01	SubIndex 001	RO	1P158442SBTN0008jckp1KELM3704 Q1 2P482001000016
10F0:0	Backup parameter handling	RO	> 1 <
10F3:0	Diagnosis History	RO	> 21 <
10F8	Actual Time Stamp	RO	0x170bfb277e

- The object 0x10E2 will be introduced into stock products in the course of a necessary firmware revision.
- From TwinCAT 3.1. build 4024.24 the functions *FB_EcCoEReadBIC* and *FB_EcCoEReadBTN* are available in the *Tc2_EtherCAT Library* from v3.3.19.0 for reading into the PLC.
- For processing the BIC/BTN data in the PLC, the following auxiliary functions are available in *Tc2_Uilities* from TwinCAT 3.1 build 4024.24 onwards
 - *F_SplitBIC*: The function splits the Beckhoff Identification Code (BIC) *sBICValue* into its components based on known identifiers and returns the recognized partial strings in a structure *ST_SplitBIC* as return value.
 - *BIC_TO_BTN*: The function extracts the BTN from the BIC and returns it as a value.
- Note: in the case of electronic further processing, the BTN is to be handled as a string(8); the identifier "SBTN" is not part of the BTN.
- Technical background
The new BIC information is additionally written as a category in the ESI-EEPROM during the device production. The structure of the ESI content is largely dictated by the ETG specifications, therefore the additional vendor-specific content is stored with the help of a category according to ETG.2010. ID 03 indicates to all EtherCAT masters that they must not overwrite these data in case of an update or restore the data after an ESI update.
The structure follows the content of the BIC, see there. This results in a memory requirement of approx. 50..200 bytes in the EEPROM.
- Special cases
 - If multiple, hierarchically arranged ESCs are installed in a device, only the top-level ESC carries the eBIC Information.
 - If multiple, non-hierarchically arranged ESCs are installed in a device, all ESCs carry the eBIC Information.
 - If the device consists of several sub-devices with their own identity, but only the top-level device is accessible via EtherCAT, the eBIC of the top-level device is located in the CoE object directory 0x10E2:01 and the eBICs of the sub-devices follow in 0x10E2:nn.

PROFIBUS, PROFINET, DeviceNet devices etc.

Currently, no electronic storage and readout is planned for these devices.

7.4 Support and Service

Beckhoff and their partners around the world offer comprehensive support and service, making available fast and competent assistance with all questions related to Beckhoff products and system solutions.

Beckhoff's branch offices and representatives

Please contact your Beckhoff branch office or representative for local support and service on Beckhoff products!

The addresses of Beckhoff's branch offices and representatives round the world can be found on her internet pages: www.beckhoff.com

You will also find further documentation for Beckhoff components there.

Support

The Beckhoff Support offers you comprehensive technical assistance, helping you not only with the application of individual Beckhoff products, but also with other, wide-ranging services:

- support
- design, programming and commissioning of complex automation systems
- and extensive training program for Beckhoff system components

Hotline: +49 5246 963 157
e-mail: support@beckhoff.com
web: www.beckhoff.com/support

Service

The Beckhoff Service Center supports you in all matters of after-sales service:

- on-site service
- repair service
- spare parts service
- hotline service

Hotline: +49 5246 963 460
e-mail: service@beckhoff.com
web: www.beckhoff.com/service

Headquarters Germany

Beckhoff Automation GmbH & Co. KG

Hülshorstweg 20
33415 Verl
Germany

Phone: +49 5246 963 0
e-mail: info@beckhoff.com
web: www.beckhoff.com

More Information:
www.beckhoff.com/epp7342-0002

Beckhoff Automation GmbH & Co. KG
Hülshorstweg 20
33415 Verl
Germany
Phone: +49 5246 9630
info@beckhoff.com
www.beckhoff.com

