

Documentation | EN

EP9521-0020

Media converter, Ethernet/EtherCAT, 100 Mbit/s, 24 V DC



Table of contents

1 Foreword	5
1.1 Notes on the documentation	5
1.2 Safety instructions	6
1.3 Documentation issue status	7
2 EtherCAT Box - Introduction	8
3 Product overview	10
3.1 Introduction	10
3.2 Technical Data	11
3.3 Scope of supply.....	12
3.4 Status LEDs	13
4 Principles of fiber-optic technology	14
4.1 Types of fiber optics	20
5 Mounting and connection	21
5.1 Mounting	21
5.1.1 Dimensions	21
5.1.2 Fixing.....	22
5.1.3 Functional earth	22
5.1.4 Tightening torques for plug connectors.....	22
5.2 Connection	23
5.2.1 EtherCAT	23
5.2.2 Fiber-optic cables.....	25
5.2.3 Supply voltages.....	27
5.3 UL Requirements	30
5.4 Disposal	31
6 Commissioning and configuration	32
6.1 Integrating into a TwinCAT project.....	33
6.2 Configuration for EtherCAT	34
6.3 Configuration for Ethernet	37
6.3.1 Link Loss Forwarding.....	38
6.4 Restoring the delivery state.....	39
7 Appendix	40
7.1 General operating conditions	40
7.2 Accessories	41
7.3 Version identification of EtherCAT devices	42
7.3.1 General notes on marking.....	42
7.3.2 Version identification of IP67 modules	43
7.3.3 Beckhoff Identification Code (BIC).....	44
7.3.4 Electronic access to the BIC (eBIC).....	46
7.4 Support and Service.....	48

1 Foreword

1.1 Notes on the documentation

Intended audience

This description is only intended for the use of trained specialists in control and automation engineering who are familiar with the applicable national standards.

It is essential that the documentation and the following notes and explanations are followed when installing and commissioning these components.

The qualified personnel is obliged to always use the currently valid documentation.

The responsible staff must ensure that the application or use of the products described satisfy all the requirements for safety, including all the relevant laws, regulations, guidelines and standards.

Disclaimer

The documentation has been prepared with care. The products described are, however, constantly under development.

We reserve the right to revise and change the documentation at any time and without prior announcement.

No claims for the modification of products that have already been supplied may be made on the basis of the data, diagrams and descriptions in this documentation.

Trademarks

Beckhoff®, ATRO®, EtherCAT®, EtherCAT G®, EtherCAT G10®, EtherCAT P®, MX-System®, Safety over EtherCAT®, TC/BSD®, TwinCAT®, TwinCAT/BSD®, TwinSAFE®, XFC®, XPlanar® and XTS® are registered trademarks of and licensed by Beckhoff Automation GmbH.

Other designations used in this publication may be trademarks whose use by third parties for their own purposes could violate the rights of the owners.



EtherCAT® is registered trademark and patented technology, licensed by Beckhoff Automation GmbH, Germany.

Copyright

© Beckhoff Automation GmbH & Co. KG, Germany.

The reproduction, distribution and utilization of this document as well as the communication of its contents to others without express authorization are prohibited.

Offenders will be held liable for the payment of damages. All rights reserved in the event of the grant of a patent, utility model or design.

Third-party brands

Trademarks of third parties may be used in this documentation. You can find the trademark notices here:

<https://www.beckhoff.com/trademarks>

1.2 Safety instructions

Safety regulations

Please note the following safety instructions and explanations!
Product-specific safety instructions can be found on following pages or in the areas mounting, wiring, commissioning etc.

Exclusion of liability

All the components are supplied in particular hardware and software configurations appropriate for the application. Modifications to hardware or software configurations other than those described in the documentation are not permitted, and nullify the liability of Beckhoff Automation GmbH & Co. KG.

Personnel qualification

This description is only intended for trained specialists in control, automation and drive engineering who are familiar with the applicable national standards.

Signal words

The signal words used in the documentation are classified below. In order to prevent injury and damage to persons and property, read and follow the safety and warning notices.

Personal injury warnings

⚠ DANGER

Hazard with high risk of death or serious injury.

⚠ WARNING

Hazard with medium risk of death or serious injury.

⚠ CAUTION

There is a low-risk hazard that could result in medium or minor injury.

Warning of damage to property or environment

NOTICE

The environment, equipment, or data may be damaged.

Information on handling the product



This information includes, for example:
recommendations for action, assistance or further information on the product.

1.3 Documentation issue status

Version	Comment
1.3	<ul style="list-style-type: none"> • Technical data updated • Figures updated • “Principles of fiber-optic technology” added • Structure update
1.2	<ul style="list-style-type: none"> • First publication in PDF format • Dimensions updated • UL requirements updated
1.1	<ul style="list-style-type: none"> • Structure update
1.0.0	<ul style="list-style-type: none"> • Migration
0.2.0	<ul style="list-style-type: none"> • Power connection updated
0.1.0	<ul style="list-style-type: none"> • First preliminary version

Firmware and hardware versions

This documentation refers to the firmware and hardware version that was applicable at the time the documentation was written.

The module features are continuously improved and developed further. Modules having earlier production statuses cannot have the same properties as modules with the latest status. However, existing properties are retained and are not changed, so that older modules can always be replaced with new ones.

The firmware and hardware version (delivery state) can be found in the batch number (D-number) printed on the side of the EtherCAT Box.

Syntax of the batch number (D-number)

D: WW YY FF HH

WW - week of production (calendar week)

YY - year of production

FF - firmware version

HH - hardware version

Example with D no. 29 10 02 01:

29 - week of production 29

10 - year of production 2010

02 - firmware version 02

01 - hardware version 01

Further information on this topic: [Version identification of EtherCAT devices \[► 42\]](#).

2 EtherCAT Box - Introduction

The EtherCAT system has been extended with EtherCAT Box modules with protection class IP67. Through the integrated EtherCAT interface the modules can be connected directly to an EtherCAT network without an additional Coupler Box. The high-performance of EtherCAT is thus maintained into each module.

The extremely low dimensions of only 126 x 30 x 26.5 mm (h x w x d) are identical to those of the Fieldbus Box extension modules. They are thus particularly suitable for use where space is at a premium. The small mass of the EtherCAT modules facilitates applications with mobile I/O interface (e.g. on a robot arm). The EtherCAT connection is established via screened M8 connectors.

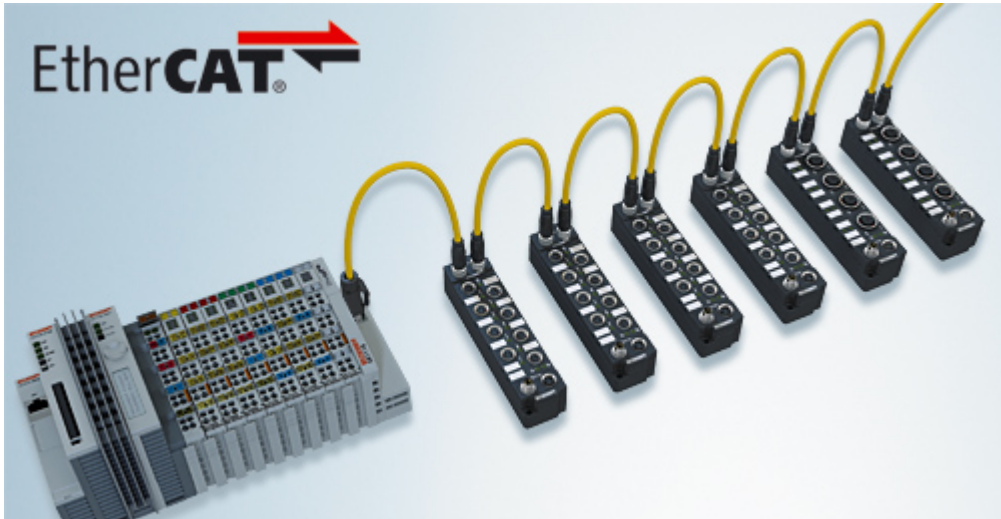

Fig. 1: EtherCAT Box Modules within an EtherCAT network

The robust design of the EtherCAT Box modules enables them to be used directly at the machine. Control cabinets and terminal boxes are now no longer required. The modules are fully sealed and therefore ideally prepared for wet, dirty or dusty conditions.

Pre-assembled cables significantly simplify EtherCAT and signal wiring. Very few wiring errors are made, so that commissioning is optimized. In addition to pre-assembled EtherCAT, power and sensor cables, field-configurable connectors and cables are available for maximum flexibility. Depending on the application, the sensors and actuators are connected through M8 or M12 connectors.

The EtherCAT modules cover the typical range of requirements for I/O signals with protection class IP67:

- digital inputs with different filters (3.0 ms or 10 μ s)
- digital outputs with 0.5 or 2 A output current
- analog inputs and outputs with 16 bit resolution
- Thermocouple and RTD inputs
- Stepper motor modules

XFC (eXtreme Fast Control Technology) modules, including inputs with time stamp, are also available.



Fig. 2: EtherCAT Box with M8 connections for sensors/actuators



Fig. 3: EtherCAT Box with M12 connections for sensors/actuators

Basic EtherCAT documentation

i You will find a detailed description of the EtherCAT system in the Basic System Documentation for EtherCAT, which is available for download from our website (www.beckhoff.com) under Downloads.

3 Product overview

3.1 Introduction

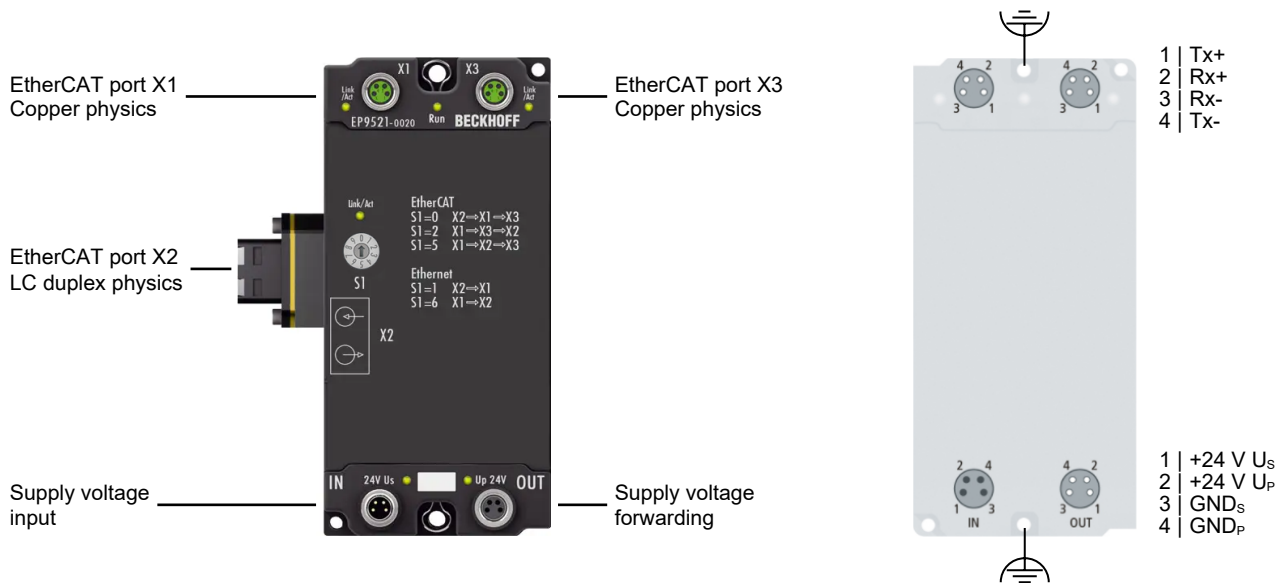

Media converter, Ethernet/EtherCAT, 100 Mbit/s, 24 V_{DC}

The EP9521-0020 EtherCAT/Industrial Ethernet Module for Industrial Fast Ethernet/100 Mbit/s is a media converter for conversion from fiber optic to copper physics and vice versa. It is suitable for multi-mode fiber optics and is used for direct transition from one medium to another. The media converter always works bidirectionally and collision-free with a constant delay and can be diagnosed as a self-contained EtherCAT device. As opposed to standard media converters, the EP9521-0020 therefore guarantees fast link control and thus a secure termination of the EtherCAT segment even in case of a fault. Since the transfer direction (copper to fiber optic | fiber optic to copper) is relevant for the bus, the device can be configured via a switch. "Link Loss Forwarding" can also be set for normal Ethernet operation via this switch.

This solution is ideal in applications where EtherCAT transfers over large distances are required or where higher EMC loads on the bus line are to be expected.

Quick links

[Technical data](#) [▶ 11]

[Optical fiber connection](#) [▶ 25]

3.2 Technical Data

All values are typical values over the entire temperature range, unless stated otherwise.

Fieldbus	
Protocol	EtherCAT / Industrial Fast Ethernet
Copper connection	2 x M8 socket, 4-pin, A-coded, shielded
Fiber optic connection	1 x LC duplex For IP67 use: only use HARTING "PushPull LC Duplex"
Data transfer medium: copper	Ethernet / EtherCAT cable (min. Cat.5), shielded
Data transfer medium: fiber optic	Multi-mode glass fiber 50/125 μm
Copper cable length	max. 100 m, twisted pair or star quad CAT5(e)
Fiber optic cable length	max. 2000 m (100BASE-FX)
EtherCAT function	Fast Ethernet / 100 Mbaud media converter <ul style="list-style-type: none"> • Cut-through switching • Port handling/link control
Ethernet function	Fast Ethernet / 100 Mbaud media converter (all protocols based on IEEE 802.3) <ul style="list-style-type: none"> • IEEE 802.3u auto-negotiation, half or full duplex, automatic settings • Link Loss Forwarding (notification direction configurable) • Store and Forward Mode (FIFO) • Unmanaged
Propagation delay	approx. 1 μs
Electrical isolation	500 V

Optical data of the fiber-optic connection	
Transceiver wavelength	typically 1310 nm
Minimum output power	-23.5 dBm avg. (50/125 μm , NA = 0.2)
Maximum output power	-14 dBm
Maximum sensitivity (Minimum required input power)	-31 dBm
Maximum permissible input power	-14 dBm

Supply voltages	
Connection	Input: M8 connector, 4-pin, A-coded Downstream connection: M8 socket, 4-pin, A-coded
U_S nominal voltage	24 V _{DC} (-15 % / +20 %)
U_S sum current: $I_{S,sum}$	max. 4 A
Current consumption from U_S	120 mA
Rated voltage U_P	24 V _{DC} (-15 % / +20 %)
U_P sum current: $I_{P,sum}$	max. 4 A
Current consumption from U_P	None. U_P is only forwarded.

Housing data	
Dimensions W × H × D	85 mm x 126 mm x 26.5 mm (without connector)
Weight	300 g
Installation position	variable
Material	PA6 (polyamide)

Environmental conditions	
Ambient temperature during operation	-25 ... +60 °C -25 ... +55 °C according to cURus
Ambient temperature during storage	-40 ... +85 °C
Vibration resistance, shock resistance	conforms to EN 60068-2-6 / EN 60068-2-27 Additional tests [► 12]
EMC immunity / emission	conforms to EN 61000-6-2 / EN 61000-6-4
Protection class	IP65, IP66, IP67 (conforms to EN 60529)

Approvals/markings	
Approvals/markings *)	CE, cURus [► 30]

*) Real applicable approvals/markings see type plate on the side (product marking).

Additional tests

The devices have undergone the following additional tests:

Test	Explanation
Vibration	10 frequency sweeps in 3 axes
	5 Hz < f < 60 Hz displacement 0.35 mm, constant amplitude
	60.1 Hz < f < 500 Hz acceleration 5 g, constant amplitude
Shocks	1000 shocks in each direction, in 3 axes
	35 g, 11 ms

3.3 Scope of supply

Make sure that the following components are included in the scope of delivery:

- 1x EtherCAT Box EP9521-0020
- 2x protective cap for EtherCAT socket, M8, green (pre-assembled)
- 1x protective cap for supply voltage input, M8, transparent (pre-assembled)
- 1x protective cap for supply voltage output, M8, black (pre-assembled)
- 10x labels, blank (1 strip of 10)



Pre-assembled protective caps do not ensure IP67 protection

Protective caps are pre-assembled at the factory to protect connectors during transport. They may not be tight enough to ensure IP67 protection.

Ensure that the protective caps are correctly seated to ensure IP67 protection.

3.4 Status LEDs

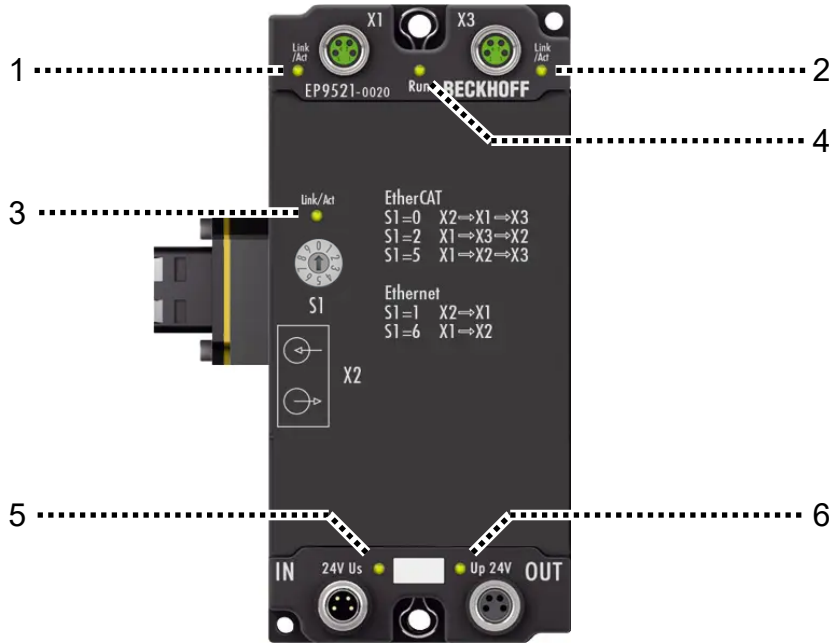

Position	Labeling	Color	Display	Description
1, 2, 3	Link/Act	green	off	No connection
			lit	"Link": EtherCAT device connected
			flashes	"Active": communication with the connected EtherCAT device
4	Run	green	off	State of the EtherCAT State Machine: INIT = initialization
			single flash	State of the EtherCAT State Machine: PREOP = function for mailbox communication and different default settings set
			flashes	State of the EtherCAT State Machine: SAFEOP = verification of the Sync Manager channels and the distributed clocks. Outputs remain in safe state.
			on	State of the EtherCAT State Machine: OP = normal operating state; mailbox and process data communication is possible
			flickers	State of the EtherCAT State Machine: BOOTSTRAP = function for box firmware updates
		orange	lit	EtherCAT mode; the rotary switch was moved during operation <i>Remedy:</i> Reset the rotary switch or reset the voltage
		red	lit	Ethernet mode; the rotary switch was moved during operation <i>Remedy:</i> Reset the rotary switch or reset the voltage
5	24V U _s	green	off	Supply voltage U _s is not present
			lit	Supply voltage U _s is present
6	Up 24V	green	off	Supply voltage U _p is not present
			lit	Supply voltage U _p is present

4 Principles of fiber-optic technology

When using fiber-optic cables for the transmission of data, there are various factors that influence the signal transmission and have to be observed in order to guarantee reliable transmission. Important principles of fiber-optic technology are described below.

Attenuation

Less light reaches the end of a connection with fiber-optic cables than is input at the start of the connection. This loss of light between the start and end of the transmission link is called attenuation. The attenuation between two points is often stated in decibels (dB). However, the decibel is not a unit, but a ratio – in the case of a fiber-optic cable it is the ratio of the light energy at the start of the connection to that at the end. It is one tenth of a Bel (B) (1 B = 10 dB). In general, decibel indicates a power level L_p from the ratio of one power P_1 to another power P_2 .

- $L_p[\text{dB}] = 10 \cdot \log_{10}(P_1/P_2)$

A positive power factor is a signal amplification, a negative power factor conversely a weakening or attenuation of the signal.

The attenuation of a fiber-optic connection is essentially determined by three influencing factors. These influencing factors are the attenuation in the fiber-optic, the attenuation in the connector and the attenuations that result from the splices in the fiber-optic connection. The total attenuation is therefore given by

- Fiber-optic link attenuation [dB] = fiber loss attenuation [dB] + connector insertion attenuation [dB] + splice insertion attenuation [dB]

Where

- fiber loss attenuation [dB] = fiber attenuation coefficient [dB/km] x length [km]
- connector insertion attenuation [dB] = number of connectors x connector insertion attenuation [dB]
- splice insertion attenuation [dB] = number of splices x splice insertion attenuation [dB]

Dispersion

A further influence that needs to be observed with the signal transmission is the dispersion. Dispersion describes the spreading or widening of a light pulse. Due to propagation differences resulting in the fiber-optic cable from different injection angles of the light waves, the optical pulse widens and is therefore wider at the output than at the input. The longer the transmission link, the greater the dispersion.

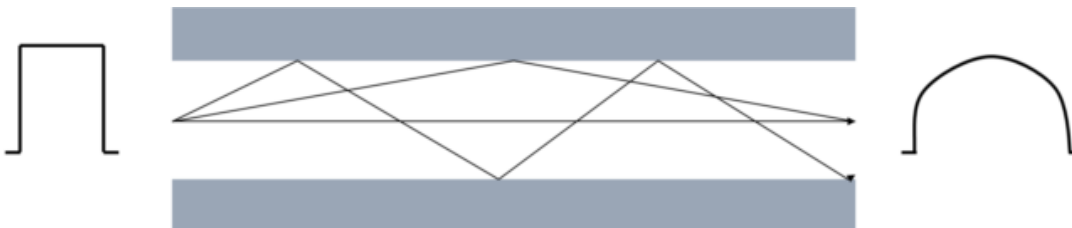

Fig. 4: Dispersion

If higher data rates are to be transmitted by the fiber-optic cable, the pulses must be sent faster at the input. What may happen then, however, is that pulses at the output run into one another and can no longer be distinguished from one another. The dispersion thus limits the maximum bandwidth of the fiber-optic connection.

The maximum bandwidth is specified in the data sheet for a fiber-optic cable as the bandwidth/length ratio in the unit MHz*km. Therefore, the longer a transmission link, the smaller the available bandwidth. The bandwidth/length ratio or product is always specified in the data sheet for a fiber-optic cable. The length of the transmission link can then be calculated with the necessary bandwidth.

$$s [\text{km}] = \text{bandwidth} [\text{MHz}] / \text{bandwidth/length ratio} [\text{MHz/km}]$$

Further influences on the signal transmission

In addition to the main influences (attenuation and dispersion) that limit the transmission link, care must be taken when installing and maintaining fiber-optic transmission links.

Sharp kinks and micro-bends in the fiber-optic lead to additional reflections in the fiber, as a result of which the influences of the attenuation and dispersion are increased. The specified bending radii of fiber-optic cables must be adhered to.

Poorly installed connectors also have a great influence on the signal quality. In case of poor connections, the fiber-optic may be too far away from the connecting piece, so that the light waves do not enter the fiber at the right angle of entry.

The third influence on the signal transmission that needs to be observed is soiling of, or damage to the ends of optical fibers. Due to the size of the fibers, often just 125 µm, dirt or damage cannot be discerned with the naked eye. Only a microscope with a sufficient magnification (at least factor 100) enables the fiber ends to be checked. To prevent soiling, the cable cap supplied with the cable should always be fitted to the fiber end.

Power and attenuation budget

The power budget specifies the minimum power available between transmitter and receiver. The attenuation budget describes the attenuation between transmitter and receiver due to the three attenuation factors – fiber, connectors and splices – described above.

Transceivers (derived from the words transmitter and receiver) are installed in fiber-optic transmitters and receivers. A transceiver is a combined transmitting and receiving device. The transceiver data sheet usually contains two key values that are required for calculating the power budget. These values are the **minimum output power** (worst level) of the transmitter and the **maximum sensitivity** (i.e. lowest received power/level) of the receiver at which it still recognizes signals.

Both values are often specified in the unit decibel milliwatt (dBm). dBm describes the power level in relation to a reference value of 1 mW.

$$L_P[\text{dB}] = 10 \cdot \log_{10}(P_1/1 \text{ mW})$$

0 dBm then corresponds to a power value of 1 mW, positive dBm values indicate power values >1 mW and negative dBm values indicate power values <1 mW.

For the technical application assessment, the difference between the minimum output power and the maximum sensitivity at the input is therefore regarded as the available power budget as a worst-case assumption:

$$\text{Leistungsbudget} = \text{minimale Ausgangsleistung} - \text{maximale Empfindlichkeit}$$

Note: In practice, the power budget is usually higher because the typical transmission power is higher than the minimum. However, this is not always the case.

Cable attenuation results from the attenuation influences described above.

$$\text{Dämpfungspegel [dB]} = \text{Faserverlustdämpfung [dB]} + \text{Steckereinfügungsdämpfung [dB]} + \text{Spleißeinfügungsdämpfung [dB]}.$$

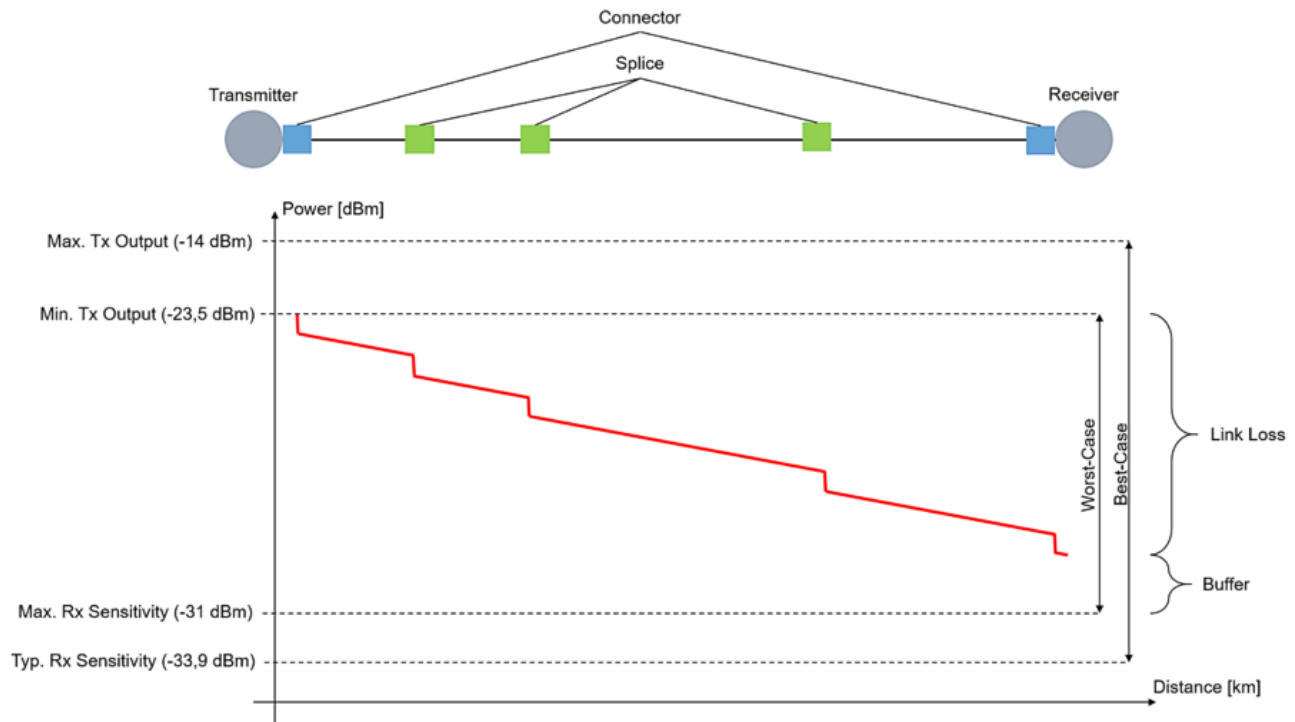

Fig. 5: Power and attenuation budget

The attenuation level must not exceed the power budget, otherwise reliable reception is no longer possible. A reserve as high as >3 dB is recommended (see diagram) to ensure long-term operation for years despite aging effects as sources in the transmitter age and lose power, connectors or splices deteriorate, or connectors become dirty when disconnected for rerouting or testing. If cables are accidentally cut later, a reserve is useful to accommodate splices for reconnection.

Example calculation of power and attenuation budget

In an example calculation, the power and attenuation budget is to be calculated for a transmission link of 2.1 km in length between an EK1501 and an EK1521 with a multimode fiber in the strength 50/125 μm. The two fiber-optic couplers under consideration have the same transceiver.

First of all, the power budget existing between the two couplers must be calculated:

Power budget	
Parameter	Value
Minimum output power [50/125 μm]	-23.5 dBm
Maximum sensitivity	-31 dBm
Power budget	7.5 dBm

In the next step, the attenuation budget, i.e. the attenuation over the entire transmission link, must be calculated. A multimode fiber in the strength 50/125 μm from Beckhoff (ZK1091-1001-xxxx) is used for this example. A maximum attenuation of 0.8 dB/km at a wavelength of 1310 nm is specified in the data sheet for the fiber-optic cable. The cable is connected at both ends via an SC connector. The typical attenuation value of SC connectors is 0.25 dB, but it should nevertheless be checked for the specific application. Three splices were made over the entire link. A typical attenuation of 0.3 dB can be assumed per splice connection; however, the attenuation of a splice is dependent on its quality. The attenuation budget must be calculated from these values in the following.

Attenuation budget		
Parameter	Number	Value
Fiber loss attenuation (0.8 dB/km)	2.1 km	1.68 dB
Connector insertion attenuation (0.25 dB)	2	0.5 dB
Splice insertion attenuation (0.3 dB)	3	0.9 dB
Attenuation budget		3.08 dB

If the attenuation budget is now subtracted from the power budget, a power buffer of 4.42 dB results. This is greater than 3 dB and is therefore sufficient as a buffer for most applications, so that an additional splice or slight soiling of the fiber would not lead to failure of the data transmission.

If several values are given for a parameter in the data sheet for transceivers, cables or connectors, the worst value should always be taken and used for the calculation.

For the transmission link under consideration, the bandwidth/length ratio specified in the data sheet for the fiber should always be considered in addition to the attenuation and, as shown above, one should calculate whether the implementation of the length of the transmission link is possible with the desired bandwidth and the fiber.

Overdrive

An optical receiver can not only receive too little light power (and thus cause data errors or bit errors), but also too much, resulting in overdriving with the same immediate consequences and possibly even long-term damage. In addition to the sensitivity of the receiver at low transmission power, compliance with the maximum permissible optical input power must therefore also be checked. Overloading can occur in particular, but not exclusively, with short connections and SFP modules.

The minimum and maximum transmit and receive power of an optical transceiver are usually specified in the technical data.

If the transmit power of the remote station exceeds the maximum permissible receive power of the receiver, an optical attenuator should be used to attenuate the transmit power and prevent the receiver from being overloaded. However, it should be borne in mind that optical components and links age over time, which is why the attenuator should not be set too high.

The connection between an EK1521 and a multimode SFP, operated in the CU1521-0020, is now considered as an example:

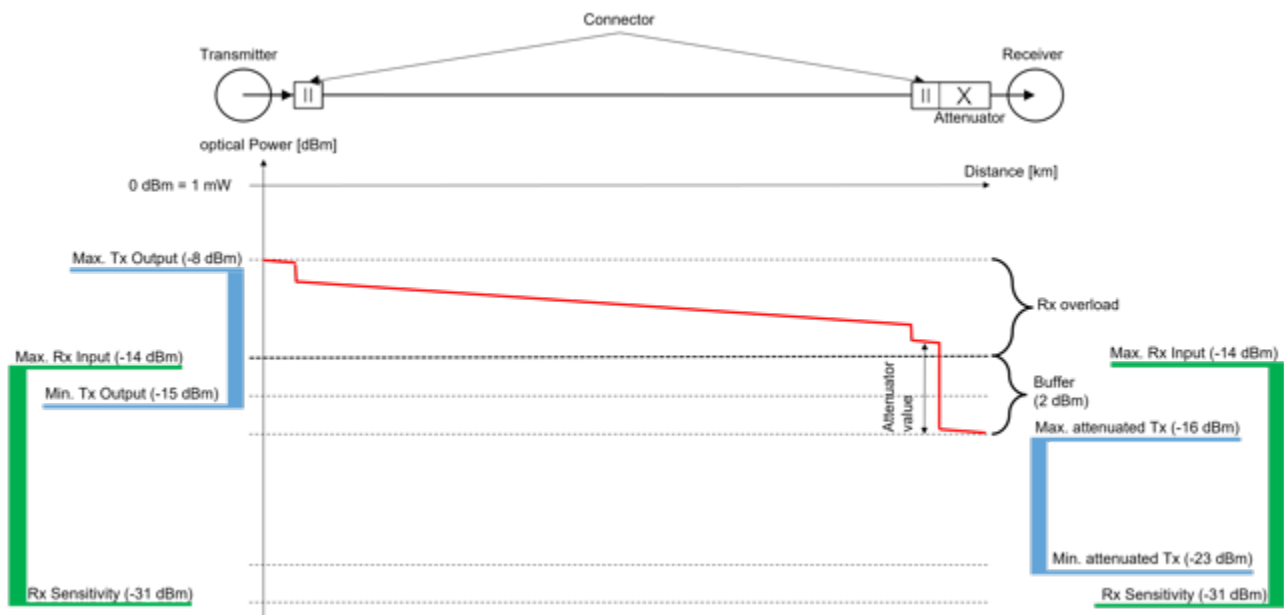

Fig. 6: Performance curve via the EK1521 vs. CU1521-0020 coupling

- Left scale: The maximum permanently permissible optical input power of the EK1521 (green: receiver, Rx) is -14 dBm¹⁾ and the maximum transmission power of the SFP (blue: transmitter, Tx) is -8 dBm; it is therefore significantly higher. Damage may occur with direct/short connections.
- The signal must therefore be attenuated by at least 6 dB on the path between the transmitter and receiver to prevent the receiver from overloading. It is also advisable to allow for a reserve of around 2 dB.
- Assume a fiber optic cable length of 2 km at 1.25 dB/km, which results in an attenuation of 2.5 dB*). With two connectors of 0.25 dB* each, 0.5 dB attenuation is added. The attenuation budget of the transmission path is therefore 3 dB.
- With an attenuation budget of 3 dB and a reserve of 2 dB, an attenuator with 5 dB is therefore inserted in the transmitter-receiver path.

$$\text{Calculation: Attenuation}_{\text{Attenuator}} = \text{Attenuation}_{\text{necessary}} + \text{Attenuation}_{\text{reserve}} - \text{Attenuation}_{\text{budget}} = 6 \text{ dB} + 2 \text{ dB} - 3 \text{ dB} = 5 \text{ dB}$$

- Right scale: The power ratio between receivable and actually received optical power, taking into account the transmission path and 5 dB attenuator, is as shown: the attenuated incoming transmission power (blue) is now within the permissible power range of the receiver and is therefore OK.

In some devices, the actual transmit and receive power can be viewed using the SFP diagnostic data (DDM)

Name	[X]	Online	Type	Size	>Addr...	In/Out	Linked to
Actual		00 A4 1B 42 F2 41 4...	Actual_EB3...	20.0	45.0	Input	
Temperature		38.91015624	REAL	4.0	45.0	Input	
Voltage		3.2383999	REAL	4.0	49.0	Input	
Tx Bias		10.5500002	REAL	4.0	53.0	Input	
Tx Power		-9.4423952	REAL	4.0	57.0	Input	
Rx Power		-17.5945072	REAL	4.0	61.0	Input	

Fig. 7: Real-time display of Tx/Rx power in the CU1521-0020

Note: If the line from the Tx port to the Rx port of the SFP is bridged (loopback), the Tx power transmitted can be compared with the Rx power actually received.

¹⁾ Note: The values given are example values. The specific details in the device documentation are decisive.

Evaluation of a fiber-optic transmission link by means of measurement

A fiber-optic transmission link can be described and evaluated with parameters from data sheets. In order to obtain a real result for the attenuation over the entire link, however, the link must be measured using an optical power meter (OPM). The power at the end of the transmission link can be measured with an OPM.

When measuring with an OPM, it is essential to ensure that only the required adapter (FC, SC, ...) is screwed to the OPM. If several adapters are screwed above one another to the OPM, the distance between the connector and the detector in the OPM is too large, with the result that lower power values are displayed (greater attenuation than actually exists).



OPM without adapter



OPM with FC adapter screwed on



OPM with SC adapter screwed on



OPM with FC and SC adapter screwed on -
WRONG

4.1 Types of fiber optics

General information on optical fiber types

Optical fiber are available as multimode and single mode types with different step and graded indices.

Step and graded index

Optical fiber cables consist of 2 concentric materials – the core and a cladding. These may be surrounded by a (colored) protective sheath. The core and the cladding have a different refractive index, causing the light waves (modes; a mode is a natural wave in the optical fiber) to be reflected back into the core at the boundary. Due to the step change in the index of refraction this type of fiber is referred to as step index. A gradual/parabolic transition between the index of refraction in the core and the coating (referred to as graded index) can be achieved by mixing the materials. In a graded index fiber the modes are gradually diffracted back to the core, leading to propagation-time compensation and significantly higher quality of the light pulse at the outlet compared with a multimode step index fiber, where the different light modes have different signal propagation delays (mode dispersion) with associated front distortion.

Single mode

Single mode fiber cables have a very thin core (9 μm) and therefore conduct only a single light mode with high signal quality and almost without mode dispersion. They are only available as step index fibers. Due to the high signal quality they are suitable for large transmission bandwidths $> 10 \text{ GHz}\cdot\text{km}$ and distances $> 50 \text{ km}$. The refractive index profile of single-mode fibers is dimensioned such that the multipath propagation (intermodal dispersion), which is a problem with multi-mode fibers, is omitted – the signal light propagates in a single-mode fiber only in a single guided fiber mode, hence the designation 'single-mode'. This makes considerably larger transmission distances and/or transmission bandwidths possible, and the limiting effect that arises next is the color distortion of the transmitted mode.

Multimode

Multimode fiber optics are manufactured as step index or graded index. Step index multimode fiber cables are suitable for transmission bandwidths up to $100 \text{ MHz}\cdot\text{km}$ and distances up to 1 km. Graded index multimode fiber cables with core diameters between 50 and 62.5 μm reach transmission bandwidths $> 1 \text{ GHz}\cdot\text{km}$ and ranges $> 10 \text{ km}$. Multimode means that the core of the optical fiber cable is thick enough to enable several light modes of the light employed to propagate reflectively in the cable.

5 Mounting and connection

5.1 Mounting

5.1.1 Dimensions

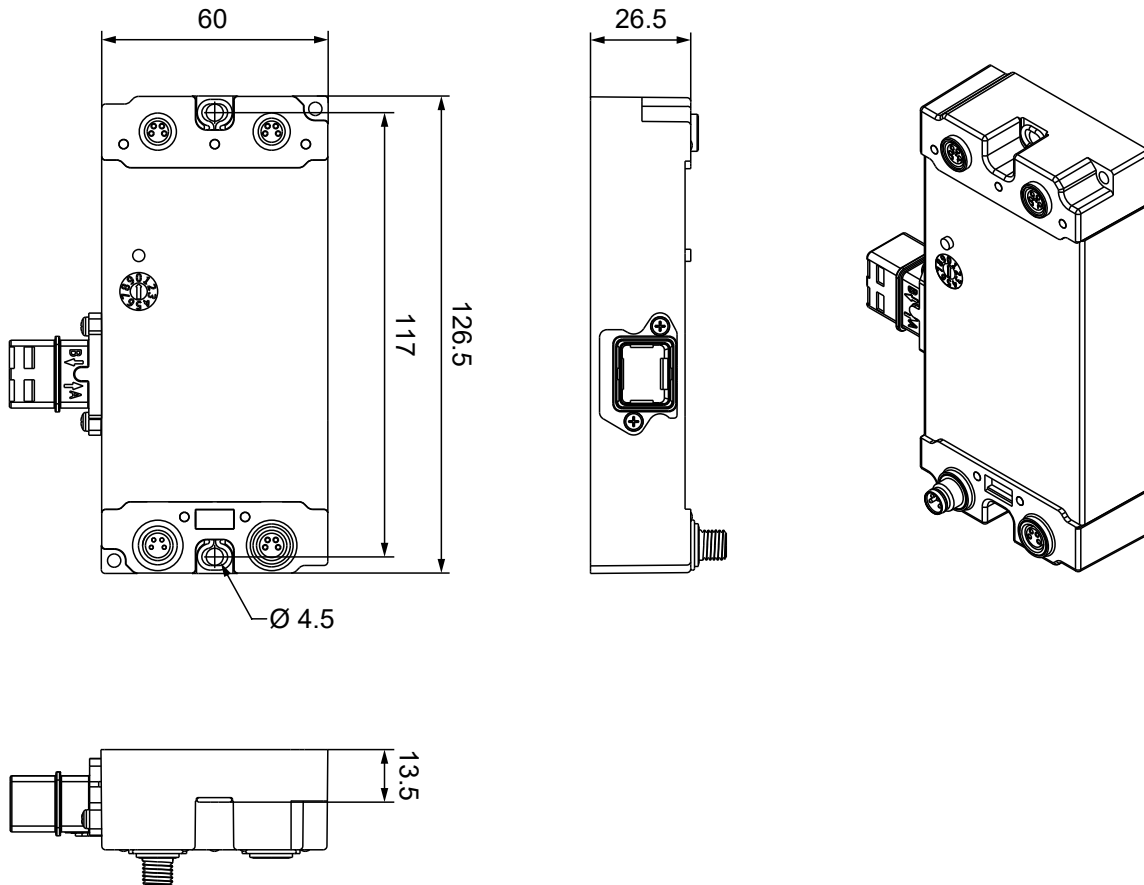

All dimensions are given in millimeters.
The drawing is not true to scale.

Housing features

Housing material	PA6 (polyamide)
Sealing compound	polyurethane
Mounting	two mounting holes Ø 4.5 mm for M4
Metal parts	brass, nickel-plated
Contacts	CuZn, gold-plated
Installation position	variable
Protection class	IP65, IP66, IP67 (conforms to EN 60529) when screwed together
Dimensions (H × W × D)	approx. 126 × 60 × 26.5 mm (without connectors)

5.1.2 Fixing

NOTICE

Dirt during assembly

Dirty connectors can lead to malfunctions. Protection class IP67 can only be guaranteed if all cables and connectors are connected.

- Protect the plug connectors against dirt during the assembly.

Mount the module with two M4 screws in the centrally located mounting holes.

5.1.3 Functional earth

The [mounting holes](#) [▶ 22] also serve as connections for the functional earth.

Make sure that the box is grounded with low impedance via both fastening screws. You can achieve this, for example, by mounting the box on a grounded machine bed.

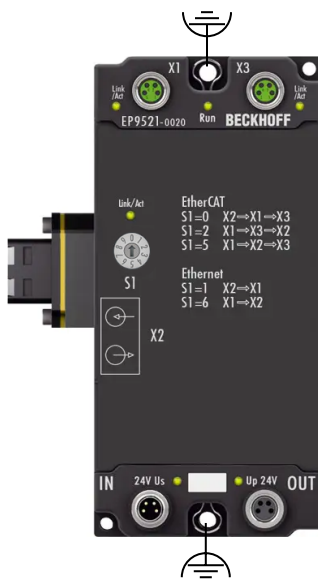

5.1.4 Tightening torques for plug connectors

Screw M8 connectors tight with a torque wrench. (e.g. ZB8801 from Beckhoff)
Torque: 0.4 Nm.

5.2 Connection

5.2.1 EtherCAT

5.2.1.1 Connectors

NOTICE

Risk of confusion: supply voltages and EtherCAT

Defect possible through incorrect insertion.

- Observe the color coding of the connectors:
 black: Supply voltages
 green: EtherCAT

EtherCAT Box Modules have two green M8 sockets for the incoming and downstream EtherCAT connections.



Fig. 8: EtherCAT connectors

Connection

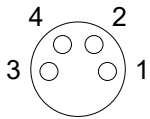

Fig. 9: M8 socket

EtherCAT	M8 socket	Core colors		
Signal	Contact	ZB9010, ZB9020, ZB9030, ZB9032, ZK1090-6292, ZK1090-3xxx-xxxx	ZB9031 and old versions of ZB9030, ZB9032, ZK1090-3xxx-xxxx	TIA-568B
Tx +	1	yellow ¹⁾	orange/white	white/orange
Tx -	4	orange ¹⁾	orange	orange
Rx +	2	white ¹⁾	blue/white	white/green
Rx -	3	blue ¹⁾	blue	green
Shield	Housing	Shield	Shield	Shield

¹⁾ Core colors according to EN 61918

i Adaptation of core colors for cables ZB9030, ZB9032 and ZK1090-3xxxx-xxxx

For standardization, the core colors of the ZB9030, ZB9032 and ZK1090-3xxx-xxxx cables have been changed to the EN61918 core colors: yellow, orange, white, blue. So there are different color codes in circulation. The electrical properties of the cables have been retained when the core colors were changed.

5.2.1.2 Status LEDs



Fig. 10: EtherCAT Status LEDs

L/A (Link/Act)

A green LED labelled "L/A" is located next to each EtherCAT socket. The LED indicates the communication state of the respective socket:

LED	Meaning
off	no connection to the connected EtherCAT device
lit	LINK: connection to the connected EtherCAT device
flashes	ACT: communication with the connected EtherCAT device

Run

Each EtherCAT slave has a green LED labelled "Run". The LED signals the status of the slave in the EtherCAT network:

LED	Meaning
off	Slave is in "Init" state
flashes uniformly	Slave is in "Pre-Operational" state
flashes sporadically	Slave is in "Safe-Operational" state
lit	Slave is in "Operational" state

[Description of the EtherCAT slave states](#)

5.2.1.3 Cables

For connecting EtherCAT devices only shielded Ethernet cables that meet the requirements of at least category 5 (CAT5) according to EN 50173 or ISO/IEC 11801 should be used.

EtherCAT uses four wires for signal transmission.

Thanks to automatic line detection ("Auto MDI-X"), both symmetrical (1:1) or cross-over cables can be used between Beckhoff EtherCAT.

[Detailed recommendations for the cabling of EtherCAT devices](#)

5.2.2 Fiber-optic cables

The EP9521-0020 is intended for combination with multimode optical fiber cables with the following properties:

- LC Duplex plug or, in the IP67 version, PushPull LC Duplex Multimode plug (SFP version) made by HARTING

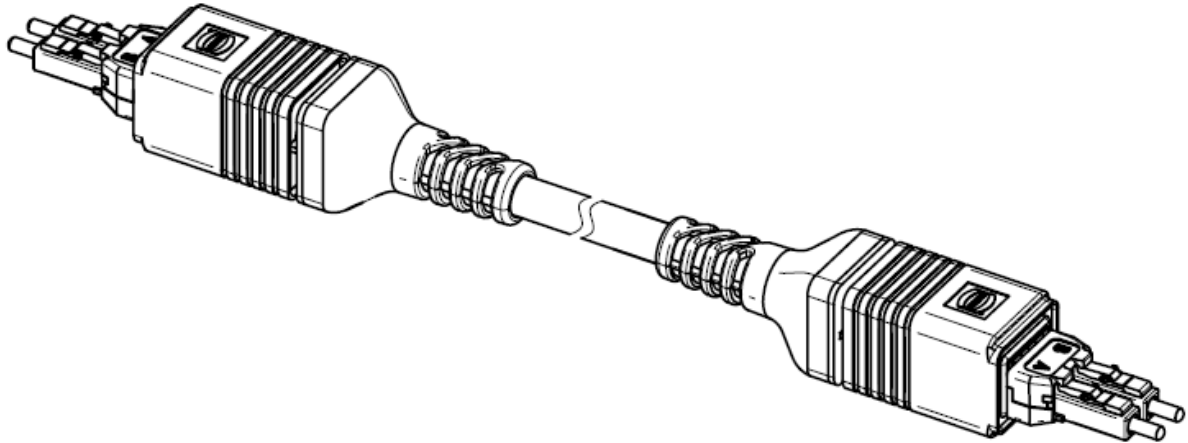

- Multimode cable 50/125 μm

● Recommended connectors

i The PushPull LC DUPLEX plug by HARTING is compulsory for IP67 use of the box. The mechanical construction guarantees the leak-tightness and suitable height offset of the fiber-optic plugs inside the protective housing. The plug is available from Beckhoff as a set of 10 under the order designation ZS1091-0001. Processing requires experience in the assembly of optical fiber cables!

In optical fibers the wavelengths 850 nm and 1300 nm are usually used for data transfer. The optical fiber cables available on the market are mostly optimized for use in one of these ranges, since the attenuation of the signal (as with copper cables) is frequency-dependent – long ranges of several km can then be achieved with the respective wavelength. In general, optical fiber cables in the 1300 nm window exhibit a lesser attenuation than in the 850 nm window.

In the EP9521-0020 a transceiver with the wavelength of 1300 nm is used.

● Range and bandwidth product

i Optical fiber cables are available in different qualities from reputable manufacturers. One of the relevant parameters for the user is the frequency-dependent bandwidth product of a cable, specified in [MHz \times km]. The greater the bandwidth product, the lower the attenuation, and therefore the larger the range that can be achieved with this cable (see ITU-T G-651). For achieving the maximum range, optical fiber cables with a maximum bandwidth product of 1300 nm should therefore be used; we recommend using class OM2 optical fiber cables (EN50173:2002). Standard optical fiber cables have a minimum bandwidth product of 500 MHz \times km at 1300 nm, higher-quality cables are suitable for distances > 500 m over > 1000 MHz \times km. In order to achieve the maximum range, the remote device must also support such ranges.

● Routing notes

i The following parameters must be taken into account in the installation of optical fiber cables

- permitted bending radius
- permitted tensile strength
- sensitivity of the exposed contact ends

Further information can be found in the following documents:

- ITU recommendation ITU-T G.651 - G.655

- EN 50173:2002
- EN 60793-2

Connecting the optical fiber cable to the box

NOTICE

Do not pull on the optical fiber cable!

So as not to damage the optical fiber cable, never pull the cable when disassembling, always pull the plug which releases the catch!

● Use of crossed optical fiber cables

i Please note that when connecting two EP9521-0020 modules together, crossed cables must be used in order to establish a connection.

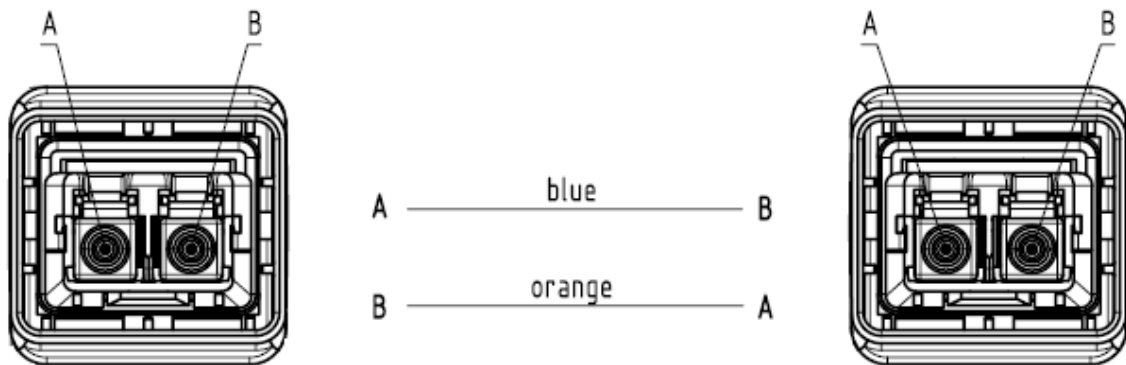

Fig. 11: Crossed optical fiber connection

● Use of blind plugs

i To protect the transceiver from environmental influences, unused connection socket should be sealed with the blind plugs provided!

5.2.3 Supply voltages

⚠ WARNING

Power supply from SELV / PELV power supply unit!

SELV / PELV circuits (safety extra-low voltage / protective extra-low voltage) according to IEC 61010-2-201 must be used to supply this device.

Notes:

- SELV / PELV circuits may give rise to further requirements from standards such as IEC 60204-1 et al, for example with regard to cable spacing and insulation.
- A SELV supply provides safe electrical isolation and limitation of the voltage without a connection to the protective conductor, a PELV supply also requires a safe connection to the protective conductor.

⚠ CAUTION

Observe the UL requirements

- When operating under UL conditions, observe the warnings in the chapter [UL Requirements](#) [▶ 30].

The EtherCAT Box has one input for two supply voltages:

- **Control voltage U_s**
The following sub-functions are supplied from the control voltage U_s :
 - the fieldbus
 - the processor logic
 - typically the inputs and the sensors if the EtherCAT Box has inputs.
- **Peripheral voltage U_p**
For EtherCAT Box modules with digital outputs the digital outputs are typically supplied from the peripheral voltage U_p . U_p can be supplied separately. If U_p is switched off, the fieldbus function, the function of the inputs and the supply of the sensors are maintained.

The exact assignment of U_s and U_p can be found in the pin assignment of the I/O connections.

Redirection of the supply voltages

The power IN and OUT connections are bridged in the module. Hence, the supply voltages U_s and U_p can be passed from EtherCAT Box to EtherCAT Box in a simple manner.

NOTICE

Note the maximum current!

Ensure that the permitted current for the connectors is not exceeded when routing the supply voltages U_s and U_p :

M8 connector: max. 4 A
7/8" connector: max 16 A

NOTICE

Unintentional cancellation of the electrical isolation possible

In some types of EtherCAT Box modules the ground potentials GND_s and GND_p are connected.

- If several EtherCAT Box modules are supplied with the same electrically isolated voltages, check whether there is an EtherCAT Box among them in which the ground potentials are connected.

5.2.3.1 Connectors

NOTICE

Risk of confusion: supply voltages and EtherCAT

Defect possible through incorrect insertion.

- Observe the color coding of the connectors:
 black: Supply voltages
 green: EtherCAT



Fig. 12: Connectors for supply voltages

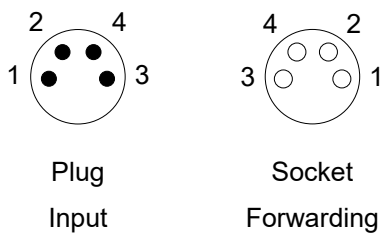

Fig. 13: M8 connector

Contact	Function	Description	Core color ¹⁾
1	U _s	Control voltage	Brown
2	U _p	Peripheral voltage	White
3	GND _s	GND to U _s	Blue
4	GND _p	GND to U _p	Black

¹⁾ The core colors apply to cables of the type: Beckhoff ZK2020-3xxx-xxxx

5.2.3.2 Status LEDs



Fig. 14: Status LEDs for the supply voltages

LED	Display	Meaning
U _s (control voltage)	off	The supply voltage U _s is not available.
	green illuminated	The supply voltage U _s is available.
U _p (peripheral voltage)	off	The supply voltage U _p is not available.
	green illuminated	The supply voltage U _p is available.

5.2.3.3 Conductor losses

Take into account the voltage drop on the supply line when planning a system. Avoid the voltage drop being so high that the supply voltage at the box lies below the minimum nominal voltage. Variations in the voltage of the power supply unit must also be taken into account.

Voltage drop on the supply line

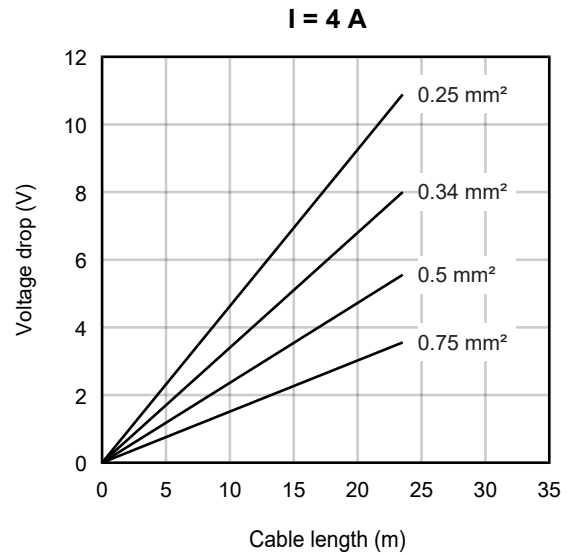
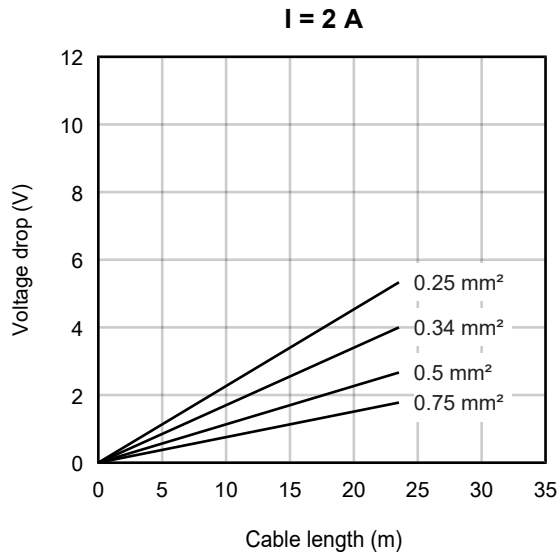

5.3 UL Requirements

The installation of the EtherCAT Box Modules certified by UL has to meet the following requirements.

Supply voltage

⚠ CAUTION

CAUTION!

This UL requirements are valid for all supply voltages of all marked EtherCAT Box Modules!
For the compliance of the UL requirements the EtherCAT Box Modules should only be supplied

- by a 24 V_{DC} supply voltage, supplied by an isolating source and protected by means of a fuse (in accordance with UL248), rated maximum 4 Amp, or
- by a 24 V_{DC} power source, that has to satisfy *NEC class 2*.
A *NEC class 2* power supply shall not be connected in series or parallel with another (class 2) power source!

⚠ CAUTION

CAUTION!

To meet the UL requirements, the EtherCAT Box Modules must not be connected to unlimited power sources!

Networks

⚠ CAUTION

CAUTION!

To meet the UL requirements, EtherCAT Box Modules must not be connected to telecommunication networks!

Ambient temperature range

⚠ CAUTION

CAUTION!

To meet the UL requirements, EtherCAT Box Modules has to be operated only at an ambient temperature range of -25 °C to +55 °C!

Marking for UL

All EtherCAT Box Modules certified by UL (Underwriters Laboratories) are marked with the following label.



Fig. 15: UL label

5.4 Disposal



Products marked with a crossed-out wheeled bin shall not be discarded with the normal waste stream. The device is considered as waste electrical and electronic equipment. The national regulations for the disposal of waste electrical and electronic equipment must be observed.

6 Commissioning and configuration

The EP9521-0020 media converter physically converts 10/100 Mbit telegrams (Fast Ethernet) from copper physics (M8 socket) to fiber optic (LC duplex connector) and back. Special behavior is expected from the converter, depending on whether EtherCAT or standard Ethernet telegrams are to be transferred.

Configuration via rotary switch

Before commissioning, set the desired protocol (EtherCAT / Ethernet) and the frame running direction using switch S1:

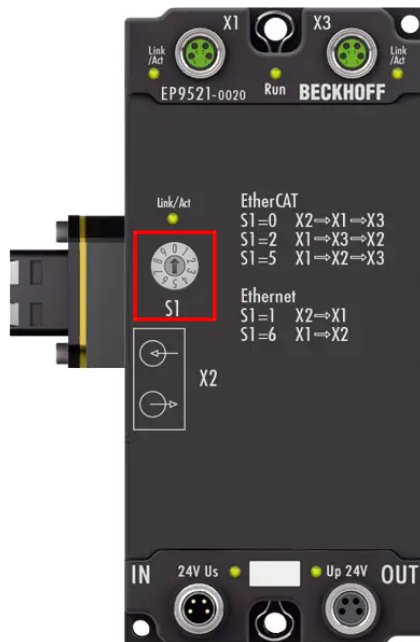

The EP9521-0020 deals with setting the rotary switch when the operating voltage is applied, unless the rotary switch is in an invalid position. The EP9521-0020 then takes over the setting as soon as the rotary switch is set to a valid position.

If the rotary switch is moved during valid operation, the EP9521-0020 does not alter its function, but indicates this state through its status LEDs, see chapter [Status LEDs](#) [► 13]. The switch setting must be rectified before the voltage is re-applied!

The possible switch settings for the available protocols can be found in the following chapters:

- [Configuration for EtherCAT](#) [► 34]
- [Configuration for Ethernet](#) [► 37]

6.1 Integrating into a TwinCAT project



The procedure for integration in a TwinCAT project is described in these [Quick start guide](#).

6.2 Configuration for EtherCAT

The EP9521-0020 fulfills the following requirements for use as an EtherCAT media converter:

- Constant low propagation delay of the frames, regardless of the frame length
- Fast link detection when the connection is established and interrupted
- Identification as separate EtherCAT device with diagnostic function

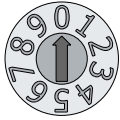
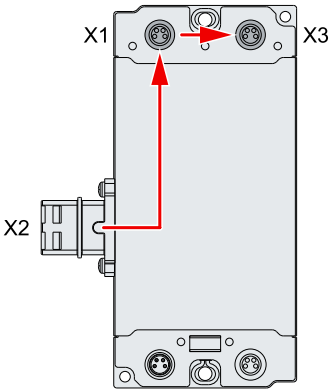
Before commissioning, set the desired running direction of the EtherCAT frames using rotary switch S1:

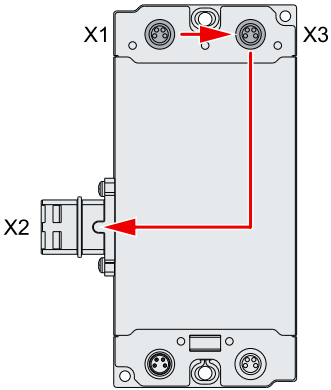
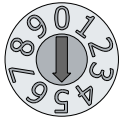
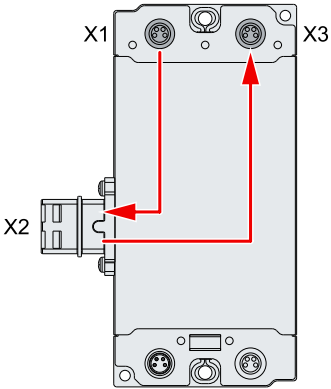
Rotary switch S1	Switch position	Running direction of the EtherCAT frames
	0	X2 ► X1 ► X3 
	2	X1 ► X3 ► X2 
	5	X1 ► X2 ► X3 

Example

In the following illustration, the EP9521-0020 are operated as follows:

- The left EP9521-0020 as a copper to fiber optic media converter (S1 = 5)
- The right-hand EP9521-0020 as a fiber optic to copper media converter (S1 = 0)

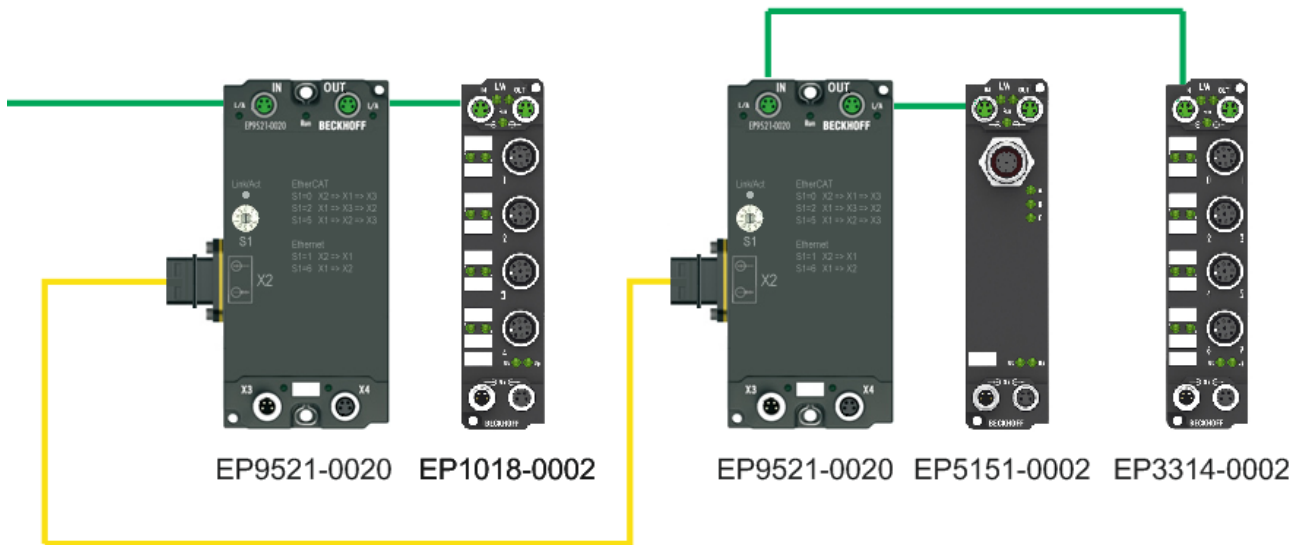

The running direction of the EtherCAT frame is thus as follows:

MASTER ► X1 (EP9521_1) ► X2(EP9521_1) ► X2(EP9521_2) ► X1(EP3314) ► X3(EP5151) ► X3(EP9521_1) ► X2(EP9521_1) ► X3(EP1018) ► MASTER

In TwinCAT, the network structure is represented as follows:

- Solution Explorer:

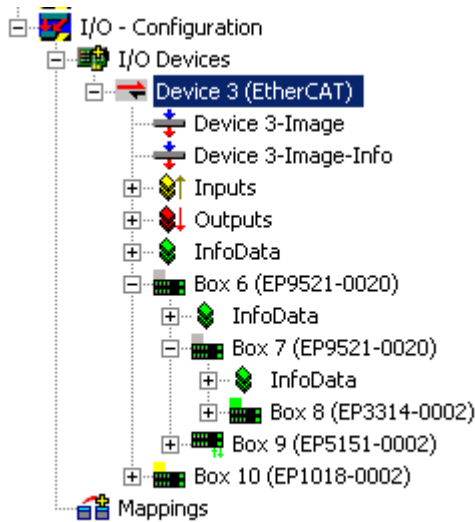

- Topology view:

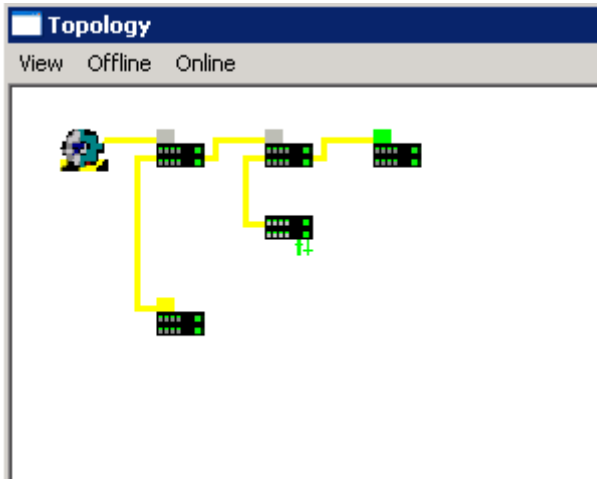



If the opposite direction of rotation is set, the subsequent behavior depends on the EtherCAT master. The scanned EP9521-0020 may be inserted at a different position in the topology, or an INIT_VPRS error message of the EtherCAT master may occur.

6.3 Configuration for Ethernet

Only ports X1 and X2 are supported in Ethernet operation.

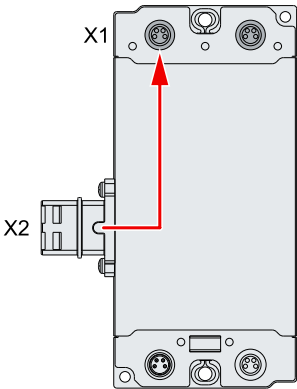
Before commissioning, set the desired running direction of the Ethernet frames via switch S1 as follows:

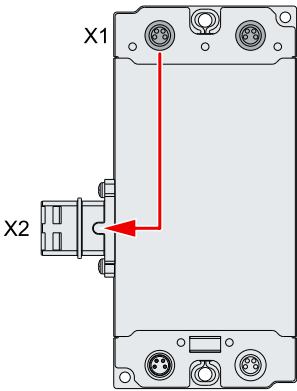
Switch S1	Switch position	Running direction of the Ethernet frames	
	1	X2 ► X1	
	6	X1 ► X2	

6.3.1 Link Loss Forwarding

An Ethernet connection is a managed point-to-point connection between two intelligent end devices.

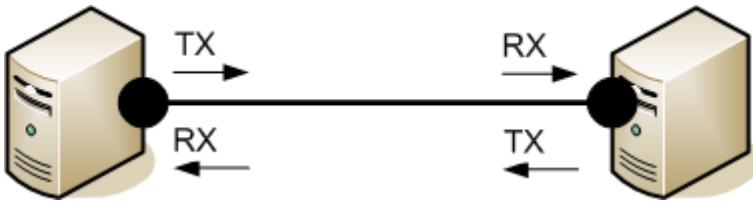

Fig. 16: Point-to-point connection between two Ethernet devices

Both devices transmit the so-called idle pattern in their Ethernet connection. When they also receive a corresponding pattern, the connection and thus the so-called *link* has been established. Both devices then know that they can use this connection. If the connection is interrupted, a link no longer exists and both devices indicate this, for example, by the LEDs.

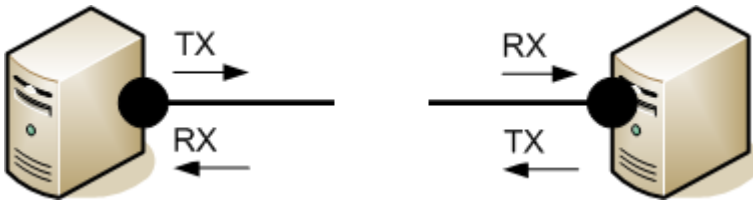

Fig. 17: Interrupted point-to-point connection

If a media converter is placed between the two stations, it too becomes an intelligent transmitter/receiver. If connection C is interrupted, device A would not necessarily be informed and would continue to send data to the converter via the existing link B, and the data would "trickle away". The EP9521 therefore supports *Link Loss Forwarding* (LLF) in **a direction that must be selected**. The message direction is selected by means of the rotary selection switch setting. Therefore, if the converter shown in Fig. *Inline media converter in Ethernet link* detects an interruption in connection C, it also removes the link from connection B.

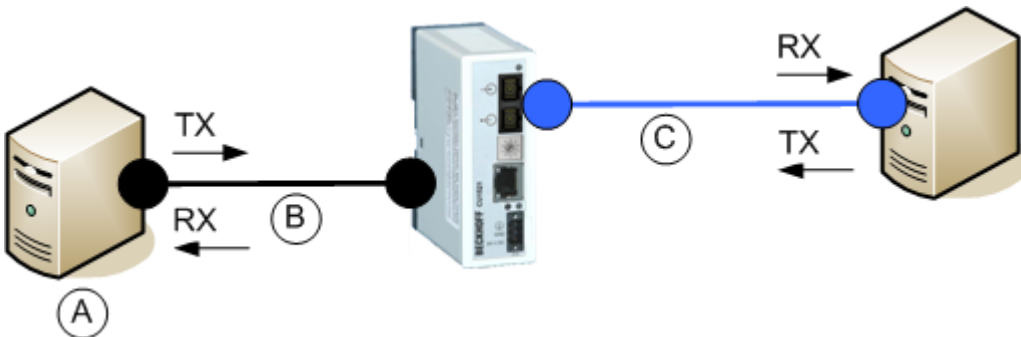

Fig. 18: Interposed media converter in the Ethernet connection

In both IP settings the EP9521 operates as a store and forward network device with checksum function. Frames that are faulty (CRC error), too short (<64 bytes) or too long (>1536 bytes) are not passed on.

6.4 Restoring the delivery state

To restore the delivery state for backup objects in ELxxxx terminals / EPxxxx- and EPPxxxx box modules, the CoE object *Restore default parameters, SubIndex 001* can be selected in the TwinCAT System Manager (Config mode).

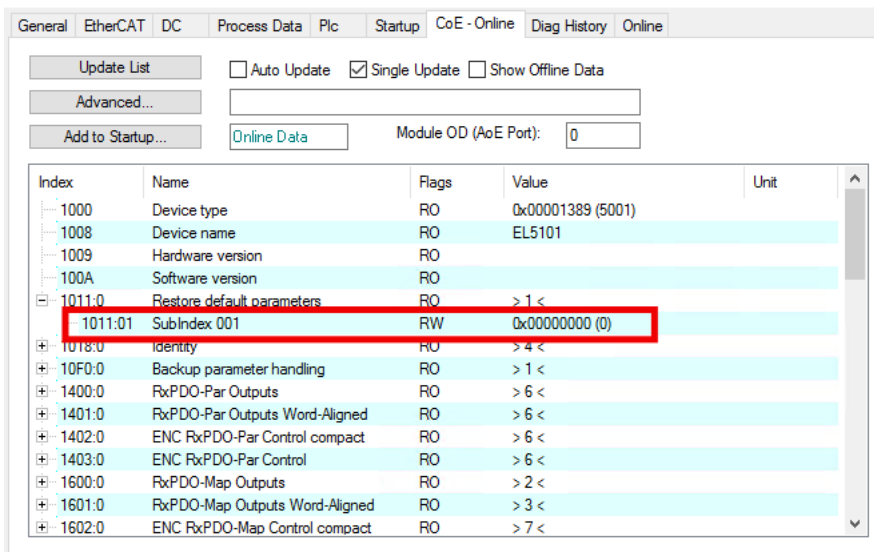

Fig. 19: Selecting the Restore default parameters PDO

Double-click on *SubIndex 001* to enter the Set Value dialog. Enter the value **1684107116** in field *Dec* or the value **0x64616F6C** in field *Hex* and confirm with OK.

All backup objects are reset to the delivery state.

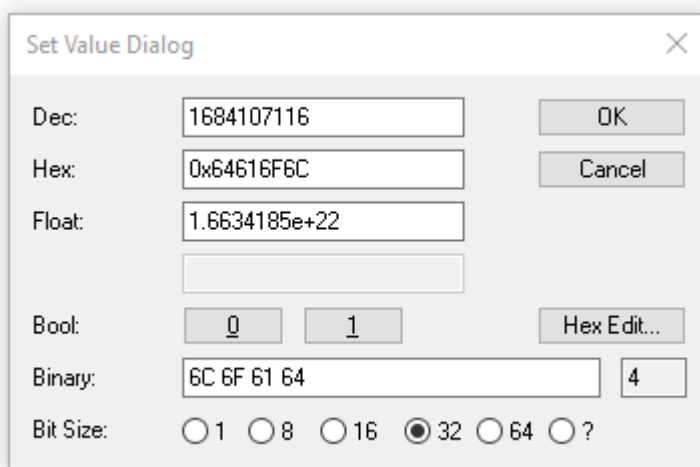

Fig. 20: Entering a restore value in the Set Value dialog

i Alternative restore value

In some older terminals / boxes the backup objects can be switched with an alternative restore value:

Decimal value: 1819238756

Hexadecimal value: 0x6C6F6164

An incorrect entry for the restore value has no effect.

7 Appendix

7.1 General operating conditions

Protection rating according to IP code

The degrees of protection are defined and divided into different classes in the IEC 60529 standard (EN 60529). Degrees of protection are designated by the letters "IP" and two numerals: **IPxy**

- Numeral x: Dust protection and contact protection
- Numeral y: Protection against water

x	Meaning
0	Not protected
1	Protected against access to dangerous parts with the back of the hand. Protected against solid foreign objects of 50 mm Ø
2	Protected against access to dangerous parts with a finger. Protected against solid foreign objects of 12.5 mm Ø
3	Protected against access to dangerous parts with a tool. Protected against solid foreign objects of 2.5 mm Ø
4	Protected against access to dangerous parts with a wire. Protected against solid foreign objects of 1 mm Ø
5	Protection against access to dangerous parts with a wire. Dust-protected. Ingress of dust is not prevented completely, although the quantity of dust able to penetrate is limited to such an extent that the proper function of the device and safety are not impaired
6	Protection against access to dangerous parts with a wire. Dust-tight. No ingress of dust

y	Meaning
0	Not protected
1	Protection against vertically falling water drops
2	Protection against vertically falling water drops when enclosure tilted up to 15°
3	Protection against spraying water. Water sprayed at an angle of up to 60° on either side of the vertical shall have no harmful effects
4	Protection against splashing water. Water splashed against the enclosure from any direction shall have no harmful effects
5	Protection against water jets.
6	Protection against powerful water jets.
7	Protected against the effects of temporary immersion in water. Ingress of water in quantities causing harmful effects shall not be possible when the enclosure is immersed in water at a depth of 1 m for 30 minutes

Chemical resistance

The resistance refers to the housing of the IP67 modules and the metal parts used. In the table below you will find some typical resistances.

Type	Resistance
Water vapor	unstable at temperatures > 100 °C
Sodium hydroxide solution (ph value > 12)	stable at room temperature unstable > 40 °C
Acetic acid	unstable
Argon (technically pure)	stable

Key

- resistant: Lifetime several months
- non inherently resistant: Lifetime several weeks
- not resistant: Lifetime several hours resp. early decomposition

7.2 Accessories

Mounting

Ordering information	Description	Link
ZS5300-0011	Mounting rail	Website

Labeling material, protective caps

Ordering information	Description
ZS5000-0010	Protective cap for M8 sockets, IP67 (50 pieces)
ZS5100-0000	Inscription labels, unprinted, 4 strips of 10
ZS5000-xxxx	Printed inscription labels on enquiry

Cables

A complete overview of pre-assembled cables can be found on the Beckhoff website: [Link](#).

Ordering information	Description	Link
ZK1090-3xxx-xxxx	EtherCAT cable M8, green	Website
ZK1093-3xxx-xxxx	EtherCAT cable M8, yellow	Website
ZK2020-3xxx-xxxx	Power cable M8, 4-pin	Website

Tools

Ordering information	Description
ZB8801-0000	Torque wrench for plugs, 0.4... 1.0 Nm
ZB8801-0001	Torque cable key for M8 / wrench size 9 for ZB8801-0000



Further accessories

Further accessories can be found in the price list for fieldbus components from Beckhoff and online at <https://www.beckhoff.com>.

7.3 Version identification of EtherCAT devices

7.3.1 General notes on marking

Designation

A Beckhoff EtherCAT device has a 14-digit designation, made up of

- family key
- type
- version
- revision

Example	Family	Type	Version	Revision
EL3314-0000-0016	EL terminal 12 mm, non-pluggable connection level	3314 4-channel thermocouple terminal	0000 basic type	0016
ES3602-0010-0017	ES terminal 12 mm, pluggable connection level	3602 2-channel voltage measurement	0010 high-precision version	0017
CU2008-0000-0000	CU device	2008 8-port fast ethernet switch	0000 basic type	0000

Notes

- The elements mentioned above result in the **technical designation**. EL3314-0000-0016 is used in the example below.
- EL3314-0000 is the order identifier, in the case of "-0000" usually abbreviated to EL3314. "-0016" is the EtherCAT revision.
- The **order identifier** is made up of
 - family key (EL, EP, CU, ES, KL, CX, etc.)
 - type (3314)
 - version (-0000)
- The **revision** -0016 shows the technical progress, such as the extension of features with regard to the EtherCAT communication, and is managed by Beckhoff.
In principle, a device with a higher revision can replace a device with a lower revision, unless specified otherwise, e.g. in the documentation.
Associated and synonymous with each revision there is usually a description (ESI, EtherCAT Slave Information) in the form of an XML file, which is available for download from the Beckhoff web site.
From 2014/01 the revision is shown on the outside of the IP20 terminals, see Fig. "EL2872 with revision 0022 and serial number 01200815".
- The type, version and revision are read as decimal numbers, even if they are technically saved in hexadecimal.

7.3.2 Version identification of IP67 modules

The serial number/ data code for Beckhoff IO devices is usually the 8-digit number printed on the device or on a sticker. The serial number indicates the configuration in delivery state and therefore refers to a whole production batch, without distinguishing the individual modules of a batch.

Structure of the serial number: **KK YY FF HH**

KK - week of production (CW, calendar week)
 YY - year of production
 FF - firmware version
 HH - hardware version

Example with serial number 12 06 3A 02:

12 - production week 12
 06 - production year 2006
 3A - firmware version 3A
 02 - hardware version 02

Exceptions can occur in the **IP67 area**, where the following syntax can be used (see respective device documentation):

Syntax: D ww yy x y z u

D - prefix designation
 ww - calendar week
 yy - year
 x - firmware version of the bus PCB
 y - hardware version of the bus PCB
 z - firmware version of the I/O PCB
 u - hardware version of the I/O PCB

Example: D.22081501 calendar week 22 of the year 2008 firmware version of bus PCB: 1 hardware version of bus PCB: 5 firmware version of I/O PCB: 0 (no firmware necessary for this PCB) hardware version of I/O PCB: 1

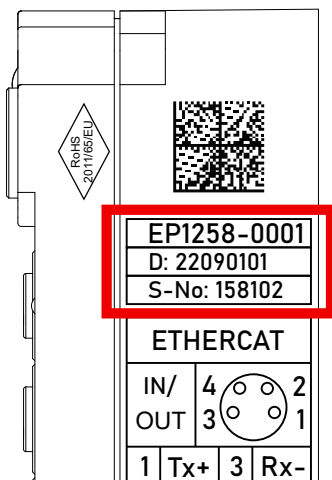

Fig. 21: EP1258-00001 IP67 EtherCAT Box with batch number/DateCode 22090101 and unique serial number 158102

7.3.3 Beckhoff Identification Code (BIC)

The Beckhoff Identification Code (BIC) is increasingly being applied to Beckhoff products to uniquely identify the product. The BIC is represented as a Data Matrix Code (DMC, code scheme ECC200), the content is based on the ANSI standard MH10.8.2-2016.

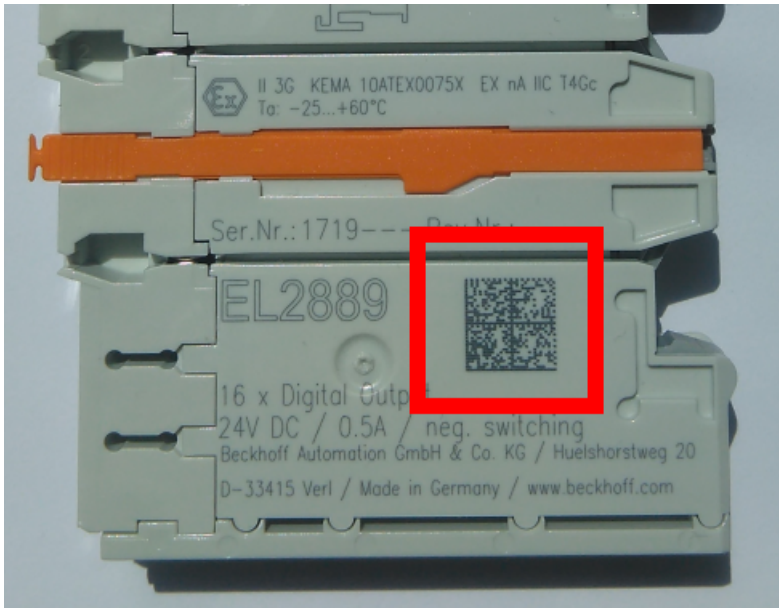

Fig. 22: BIC as data matrix code (DMC, code scheme ECC200)

The BIC will be introduced step by step across all product groups.

Depending on the product, it can be found in the following places:

- on the packaging unit
- directly on the product (if space suffices)
- on the packaging unit and the product

The BIC is machine-readable and contains information that can also be used by the customer for handling and product management.

Each piece of information can be uniquely identified using the so-called data identifier (ANSI MH10.8.2-2016). The data identifier is followed by a character string. Both together have a maximum length according to the table below. If the information is shorter, spaces are added to it.

Following information is possible, positions 1 to 4 are always present, the other according to need of production:

Position	Type of information	Explanation	Data identifier	Number of digits incl. data identifier	Example
1	Beckhoff order number	Beckhoff order number	1P	8	1P 072222
2	Beckhoff Traceability Number (BTN)	Unique serial number, see note below	SBTN	12	SBTN k4p562d7
3	Article description	Beckhoff article description, e.g. EL1008	1K	32	1KEL 1809
4	Quantity	Quantity in packaging unit, e.g. 1, 10, etc.	Q	6	Q1
5	Batch number	Optional: Year and week of production	2P	14	2P 401503180016
6	ID/serial number	Optional: Present-day serial number system, e.g. with safety products	51S	12	51S 678294
7	Variant number	Optional: Product variant number on the basis of standard products	30P	12	30P F971, 2*K183
...					

Further types of information and data identifiers are used by Beckhoff and serve internal processes.

Structure of the BIC

Example of composite information from positions 1 to 4 and with the above given example value on position 6. The data identifiers are highlighted in bold font:

1P072222**SBTN**k4p562d7**1KEL**1809 **Q1** **51S**678294

Accordingly as DMC:



Fig. 23: Example DMC **1P**072222**SBTN**k4p562d7**1KEL**1809 **Q1** **51S**678294

BTN

An important component of the BIC is the Beckhoff Traceability Number (BTN, position 2). The BTN is a unique serial number consisting of eight characters that will replace all other serial number systems at Beckhoff in the long term (e.g. batch designations on IO components, previous serial number range for safety products, etc.). The BTN will also be introduced step by step, so it may happen that the BTN is not yet coded in the BIC.

NOTICE
This information has been carefully prepared. However, the procedure described is constantly being further developed. We reserve the right to revise and change procedures and documentation at any time and without prior notice. No claims for changes can be made from the information, illustrations and descriptions in this documentation.

7.3.4 Electronic access to the BIC (eBIC)

Electronic BIC (eBIC)

The Beckhoff Identification Code (BIC) is applied to the outside of Beckhoff products in a visible place. If possible, it should also be electronically readable.

The interface that the product can be electronically addressed by is crucial for the electronic readout.

EtherCAT devices (IP20, IP67)

All Beckhoff EtherCAT devices have an ESI-EEPROM which contains the EtherCAT identity with the revision number. The EtherCAT slave information, also colloquially known as the ESI/XML configuration file for the EtherCAT master, is stored in it. See the corresponding chapter in the EtherCAT system manual ([Link](#)) for the relationships.

Beckhoff also stores the eBIC in the ESI-EEPROM. The eBIC was introduced into Beckhoff IO production (terminals, box modules) in 2020; as of 2023, implementation is largely complete.

The user can electronically access the eBIC (if present) as follows:

- With all EtherCAT devices, the EtherCAT master (TwinCAT) can read the eBIC from the ESI-EEPROM
 - From TwinCAT 3.1 build 4024.11, the eBIC can be displayed in the online view.
 - To do this, check the "Show Beckhoff Identification Code (BIC)" checkbox under EtherCAT → Advanced Settings → Diagnostics:

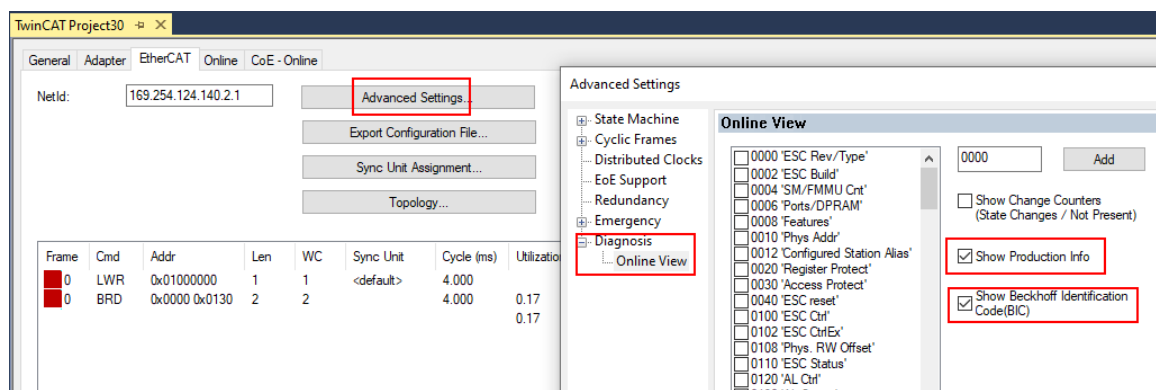

- The BTN and its contents are then displayed:

No	Addr	Name	State	CRC	Fw	Hw	Production Data	ItemNo	BTN	Description	Quantity	BatchNo	SerialNo
1	1001	Term 1 (EK1100)	OP	0,0	0	0	---						
2	1002	Term 2 (EL1018)	OP	0,0	0	0	2020 KW36 Fr	072222	k4p562d7	EL1809	1		678294
3	1003	Term 3 (EL3204)	OP	0,0	7	6	2012 KW24 Sa						
4	1004	Term 4 (EL2004)	OP	0,0	0	0	---	072223	k4p562d7	EL2004	1		678295
5	1005	Term 5 (EL1008)	OP	0,0	0	0	---						
6	1006	Term 6 (EL2008)	OP	0,0	0	12	2014 KW14 Mo						
7	1007	Term 7 (EK1110)	OP	0	1	8	2012 KW25 Mo						

- Note: As shown in the figure, the production data HW version, FW version, and production date, which have been programmed since 2012, can also be displayed with "Show production info".
- Access from the PLC: From TwinCAT 3.1. build 4024.24, the functions *FB_EcReadBIC* and *FB_EcReadBTN* for reading into the PLC are available in the Tc2_EtherCAT library from v3.3.19.0.
- EtherCAT devices with a CoE directory may also have the object 0x10E2:01 to display their own eBIC, which can also be easily accessed by the PLC:

- The device must be in PREOP/SAFEOP/OP for access:

Index	Name	Flags	Value
1000	Device type	RO	0x015E1389 (22942601)
1008	Device name	RO	ELM3704-0000
1009	Hardware version	RO	00
100A	Software version	RO	01
100B	Bootloader version	RO	J0.1.27.0
1011:0	Restore default parameters	RO	> 1 <
1018:0	Identity	RO	> 4 <
10E2:0	Manufacturer-specific Identification C...	RO	> 1 <
10E2:01	SubIndex 001	RO	1P158442SBTN0008jckp1KELM3704 Q1 2P482001000016
10F0:0	Backup parameter handling	RO	> 1 <
10F3:0	Diagnosis History	RO	> 21 <
10F8	Actual Time Stamp	RO	0x170bfb277e

- The object 0x10E2 will be preferentially introduced into stock products in the course of necessary firmware revision.
- From TwinCAT 3.1. build 4024.24, the functions *FB_EcCoEReadBIC* and *FB_EcCoEReadBTN* for reading into the PLC are available in the *Tc2_EtherCAT* library from v3.3.19.0
- The following auxiliary functions are available for processing the BIC/BTN data in the PLC in *Tc2_Uilities* as of TwinCAT 3.1 build 4024.24
 - *F_SplitBIC*: The function splits the Beckhoff Identification Code (BIC) *sBICValue* into its components using known identifiers and returns the recognized substrings in the *ST_SplittedBIC* structure as a return value
 - *BIC_TO_BTN*: The function extracts the BTN from the BIC and returns it as a return value
- Note: If there is further electronic processing, the BTN is to be handled as a string(8); the identifier "SBTN" is not part of the BTN.
- Technical background

The new BIC information is written as an additional category in the ESI-EEPROM during device production. The structure of the ESI content is largely dictated by the ETG specifications, therefore the additional vendor-specific content is stored using a category in accordance with the ETG.2010. ID 03 tells all EtherCAT masters that they may not overwrite these data in the event of an update or restore the data after an ESI update.

The structure follows the content of the BIC, see here. The EEPROM therefore requires approx. 50..200 bytes of memory.
- Special cases
 - If multiple hierarchically arranged ESCs are installed in a device, only the top-level ESC carries the eBIC information.
 - If multiple non-hierarchically arranged ESCs are installed in a device, all ESCs carry the eBIC information.
 - If the device consists of several sub-devices which each have their own identity, but only the top-level device is accessible via EtherCAT, the eBIC of the top-level device is located in the CoE object directory 0x10E2:01 and the eBICs of the sub-devices follow in 0x10E2:nn.

7.4 Support and Service

Beckhoff and their partners around the world offer comprehensive support and service, making available fast and competent assistance with all questions related to Beckhoff products and system solutions.

Beckhoff's branch offices and representatives

Please contact your Beckhoff branch office or representative for local support and service on Beckhoff products!

The addresses of Beckhoff's branch offices and representatives round the world can be found on her internet pages: www.beckhoff.com

You will also find further documentation for Beckhoff components there.

Support

The Beckhoff Support offers you comprehensive technical assistance, helping you not only with the application of individual Beckhoff products, but also with other, wide-ranging services:

- support
- design, programming and commissioning of complex automation systems
- and extensive training program for Beckhoff system components

Hotline: +49 5246 963 157
e-mail: support@beckhoff.com
web: www.beckhoff.com/support

Service

The Beckhoff Service Center supports you in all matters of after-sales service:

- on-site service
- repair service
- spare parts service
- hotline service

Hotline: +49 5246 963 460
e-mail: service@beckhoff.com
web: www.beckhoff.com/service

Headquarters Germany

Beckhoff Automation GmbH & Co. KG

Hülshorstweg 20
33415 Verl
Germany

Phone: +49 5246 963 0
e-mail: info@beckhoff.com
web: www.beckhoff.com

Trademark statements

Beckhoff®, ATRO®, EtherCAT®, EtherCAT G®, EtherCAT G10®, EtherCAT P®, MX-System®, Safety over EtherCAT®, TC/BSD®, TwinCAT®, TwinCAT/BSD®, TwinSAFE®, XFC®, XPlanar® and XTS® are registered and licensed trademarks of Beckhoff Automation GmbH.

More Information:
www.beckhoff.com/ep9521-0020/

Beckhoff Automation GmbH & Co. KG
Hülshorstweg 20
33415 Verl
Germany
Phone: +49 5246 9630
info@beckhoff.com
www.beckhoff.com

