

Documentation | EN

EP7412-x071

2-channel motion interface, BLDC motor, 48 V DC, 4 A



Table of contents

1 Foreword	5
1.1 Notes on the documentation	5
1.2 For your safety	6
1.3 Documentation issue status	7
2 Product overview	8
2.1 Introduction	9
2.2 Technical data	10
2.3 Status LEDs	13
3 Mounting and connection	14
3.1 Dimensions	14
3.2 Mounting	15
3.3 Functional earth	16
3.4 Cabling	17
3.4.1 EtherCAT	18
3.4.2 Supply voltage input.....	19
3.4.3 Supply voltage downstream connection.....	20
3.4.4 Motor	21
3.4.5 Digital I/O	22
3.5 Disposal	23
4 Commissioning and configuration	24
4.1 Integrating into a TwinCAT project.....	24
4.2 Quick start guide	25
4.2.1 Parameterization	25
4.2.2 Prepare for operation	27
4.2.3 Scan motor	28
4.2.4 Optimization, fine tuning.....	29
4.3 Determine number of pole pairs	30
4.4 Commissioning with Drive Motion Control	31
4.4.1 Requirements	31
4.4.2 Functionality	31
4.4.3 Commissioning in TwinCAT 3	32
4.4.4 Commissioning with a third-party 32-bit controller	36
4.4.5 State machine	38
4.4.6 Differences compared with Tc2_Mc2.....	39
4.4.7 Start types	39
4.4.8 Error messages.....	39
4.5 Restore the delivery state	40
5 CoE parameters	41
5.1 Configuration objects	46
5.2 Information objects	55
5.3 Input data, output data	57
5.4 Standard objects	70
6 Appendix	96

6.1	General operating conditions	96
6.2	Version identification of EtherCAT devices	97
6.2.1	General notes on marking.....	97
6.2.2	Version identification of IP67 modules	98
6.2.3	Beckhoff Identification Code (BIC).....	99
6.2.4	Electronic access to the BIC (eBIC).....	101
6.3	Support and Service.....	103

1 Foreword

1.1 Notes on the documentation

This description is intended exclusively for trained specialists in control and automation technology who are familiar with the applicable national standards.

The documentation and the following notes and explanations must be complied with when installing and commissioning the components.

The trained specialists must always use the current valid documentation.

The trained specialists must ensure that the application and use of the products described is in line with all safety requirements, including all relevant laws, regulations, guidelines, and standards.

Disclaimer

The documentation has been compiled with care. The products described are, however, constantly under development.

We reserve the right to revise and change the documentation at any time and without notice.

Claims to modify products that have already been supplied may not be made on the basis of the data, diagrams, and descriptions in this documentation.

Trademarks

Beckhoff®, ATRO®, EtherCAT®, EtherCAT G®, EtherCAT G10®, EtherCAT P®, MX-System®, Safety over EtherCAT®, TC/BSD®, TwinCAT®, TwinCAT/BSD®, TwinSAFE®, XFC®, XPlanar®, and XTS® are registered and licensed trademarks of Beckhoff Automation GmbH.

If third parties make use of the designations or trademarks contained in this publication for their own purposes, this could infringe upon the rights of the owners of the said designations.

EtherCAT 

EtherCAT® is a registered trademark and patented technology, licensed by Beckhoff Automation GmbH, Germany.

Copyright

© Beckhoff Automation GmbH & Co. KG, Germany.

The distribution and reproduction of this document, as well as the use and communication of its contents without express authorization, are prohibited.

Offenders will be held liable for the payment of damages. All rights reserved in the event that a patent, utility model, or design are registered.

Third-party trademarks

Trademarks of third parties may be used in this documentation. You can find the trademark notices here: <https://www.beckhoff.com/trademarks>.

1.2 For your safety

Safety regulations

Read the following explanations for your safety.

Always observe and follow product-specific safety instructions, which you may find at the appropriate places in this document.

Exclusion of liability

All the components are supplied in particular hardware and software configurations which are appropriate for the application. Modifications to hardware or software configurations other than those described in the documentation are not permitted, and nullify the liability of Beckhoff Automation GmbH & Co. KG.

Personnel qualification

This description is only intended for trained specialists in control, automation, and drive technology who are familiar with the applicable national standards.

Signal words

The signal words used in the documentation are classified below. In order to prevent injury and damage to persons and property, read and follow the safety and warning notices.

Personal injury warnings

⚠ DANGER

Hazard with high risk of death or serious injury.

⚠ WARNING

Hazard with medium risk of death or serious injury.

⚠ CAUTION

There is a low-risk hazard that could result in medium or minor injury.

Warning of damage to property or environment

NOTICE

The environment, equipment, or data may be damaged.

Information on handling the product



This information includes, for example: recommendations for action, assistance or further information on the product.

1.3 Documentation issue status

Version	Comment
1.0	<ul style="list-style-type: none">• First release
0.1	<ul style="list-style-type: none">• First preliminary version

Firmware and hardware versions

This documentation refers to the firmware and hardware version that was applicable at the time the documentation was written.

The module features are continuously improved and developed further. Modules having earlier production statuses cannot have the same properties as modules with the latest status. However, existing properties are retained and are not changed, so that older modules can always be replaced with new ones.

The firmware and hardware version (delivery state) can be found in the batch number (D-number) printed on the side of the EtherCAT Box.

Syntax of the batch number (D-number)

D: WW YY FF HH

WW - week of production (calendar week)

YY - year of production

FF - firmware version

HH - hardware version

Example with D no. 29 10 02 01:

29 - week of production 29

10 - year of production 2010

02 - firmware version 02

01 - hardware version 01

Further information on this topic: [Version identification of EtherCAT devices \[► 97\]](#).

2 Product overview

The following table shows the products described in this documentation and the main distinguishing features.

Product	Safety features
EP7412-0071	none
EP7412-9071	STO via FSoE

2.1 Introduction

NOTICE



Separate operating instructions for safety functions

The safety functions of product variant -9071 are implemented by the integrated EP2921 TwinSAFE option.

All information on the safety functions can be found in the operating instructions for the EP2921.



The EP7412-x071 EtherCAT Box offers two outputs with integrated MDR controller for the direct connection of 24/48 V_{DC} conveyor roller motors or other BLDC motors with max. 4 A. Two additional digital inputs/ outputs per channel enable connection of e.g. photoelectric switches or actuators.

The EP7412-x071 takes over the complete control of a roller motor independently of the manufacturer of conveyor or motor. Maximum rated current, acceleration or deceleration ramps and various other parameters can be configured and allow for a wide range of adaptations to different applications. The control of the motors is sensorless.

The EtherCAT Box measures only 309 mm × 94 mm × 25 mm can be easily mounted in the side profiles on the conveyor frame. It requires no additional protective covering. Power supply is realized via an L coded M12 connector.

2.2 Technical data

All values are typical values over the entire temperature range, unless stated otherwise.

EtherCAT	
Connection	Input: M8 female socket, 4-pin, A-coded Forwarding: M8 male plug, 4-pin, A-coded
Connection cables	PUR green 4 x AWG26 UL AWM 20963 (internal use), UL rating 30 V, UL fire class FT 2 Minimum bending radius: approx. 15 mm
Connection cable length	Input: 1.5 m Forwarding: 0.5 m

Power supply	
Nominal voltage U_S	24 V _{DC} (-15 % / +20 %)
Nominal voltage U_P	24 ... 48 V _{DC}
Connection	Input: 1 x M12 male plug, 5-pin, L-coded Forwarding: 1 x M12 female socket, 5-pin, L-coded
Connection cables	PVC 5 x 2.5 mm ² UL AWM 20549 (internal use), UL rating 300 V, UL fire class FT 2 Minimum bending radius: approx. 40 mm
Connection cable length	Input: 1.5 m Forwarding: 0.5 m
Current consumption from U_S	150 mA + load
Current consumption from U_P	Depending on the application
Total current U_S	max. 16 A at the input
Total current U_P	max. 16 A at the input

Motor channels	EP7412-0071	EP7412-9071
Number	2	
Motor type	BLDC motor	
Connection	1 x M8 connector per channel, 4-pin, A-coded	
Connection cables	PUR type 1.1 with 4 x 0.5 mm ² UL AWM 20549 (internal use), UL rating 300 V, UL flammability class FT 2 Minimum bending radius: approx. 25 mm	
Connection cable length	0.4 m per channel	
Winding inductance	min. 300 µH	
Output current per channel	4 A RMS	
Peak current per channel	8 A for 1 s	
Drive profile	DS402	
Safe stop functions	-	Safe Torque Off (STO)
Safe Torque Off implementation	-	via FSoE
Safety standards	-	<ul style="list-style-type: none"> • EN ISO 13849-1:2015 (Cat 3, PL e) • EN 61508:2010 (SIL 3) • EN 62061:2005 + A1:2013/ A2:2015 (SIL CL3)
Rotating field frequency	0 ... 599 Hz	
PWM clock frequency	16 kHz	
Current controller frequency	32 kHz	
Position controller frequency	16 kHz	
Speed controller frequency	16 kHz	

Digital combi channels per motor channel	
Number	2
Connection	1 x M12 female socket, 5-pin, A-coded
Connection cables	PVC 4 x 0.14 mm ² UL AWM 2095 (internal use), UL rating 300 V, UL fire class FT 2 Minimum bending radius: approx. 23 mm
Connection cable length	0.8 m
Nominal input voltage	24 V _{DC}
Input characteristics	Type 3 according to EN 61131-2, compatible with type 1
Nominal output voltage	24 V _{DC} from U _s , short-circuit proof
Output current	max. 0.5 A per output
Total output current	max. 1 A per connection, including sensor power supply
Sensor power supply	24 V _{DC} from U _s , short-circuit proof max. 0.5 A in total for all channels

Housing data	
Dimensions W × H × D	309 mm × 94 mm × 25 mm
Weight	1250 g
Installation position	Any
Materials	Aluminum, PC/ABS
Mounting	Two mounting holes Ø6.5 mm for M6

Ambient conditions	
Ambient temperature during operation	0 ... 50 °C
Ambient temperature during storage	-25 ... +85 °C
Vibration / shock resistance	in accordance with EN 60068-2-6 / EN 60068-2-27
EMC immunity / emission	in accordance with EN 61000-6-2 / EN 61000-6-4
Protection rating	IP54 according to EN 60529

Approvals	EP7412-0071	EP7412-9071
Approvals	CE, UL	CE, UL, TÜV SÜD

2.3 Status LEDs

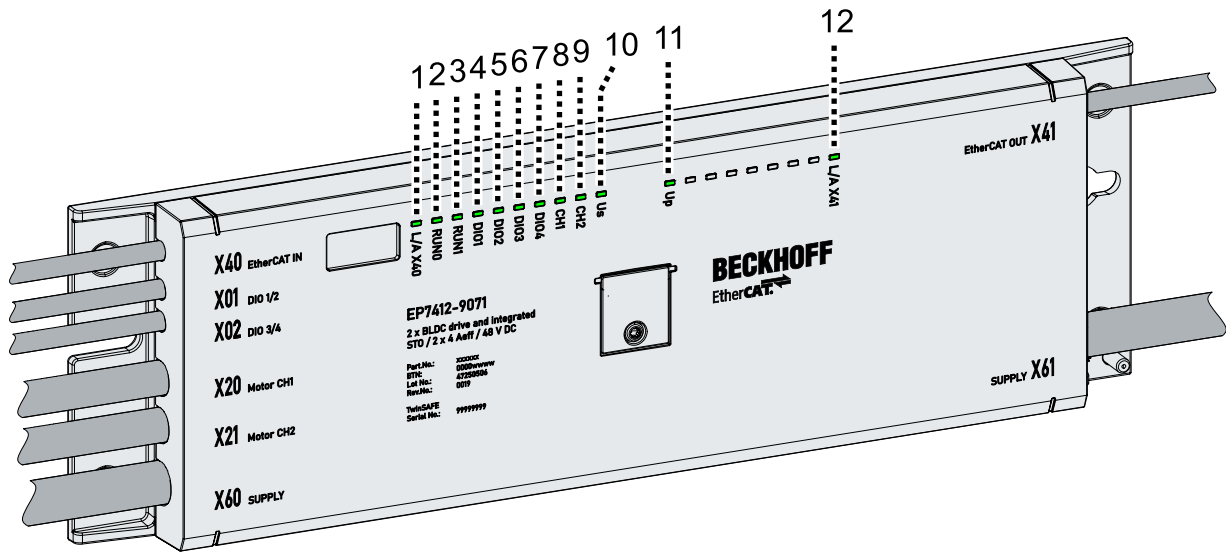

Position	Labeling	Status	Meaning
1	L/A X40	Lights up green	Link: Connection to the previous EtherCAT device
		Flashing green	Act: Communication with the previous EtherCAT device
2	RUN0	¹⁾	EtherCAT Run-LED of the safety card
3	RUN1	¹⁾	EtherCAT Run-LED of motor channel 1+2
4	DIO1	Lights up green	High level on digital combi channel 1 (X01, pin 4)
5	DIO2	Lights up green	High level on digital combi channel 2 (X01, pin 2)
6	DIO3	Lights up green	High level on digital combi channel 3 (X02, pin 4)
7	DIO4	Lights up green	High level on digital combi channel 4 (X02, pin 2)
8	CH1	Off	Axis switched off
		Lights up green	Axis in control
		Lights up red	Axis error
		Lights up yellow	Warning active + axis in control
		Flashing yellow	Warning active + axis not in control
9	CH2	Off	Axis switched off
		Lights up green	Axis in control
		Lights up red	Axis error
		Lights up yellow	Warning active + axis in control
		Flashing yellow	Warning active + axis not in control
10	U _s	Lights up green	The supply voltage U _s is present
11	U _p	Lights up green	The supply voltage U _p is present
12	L/A X41	Lights up green	Link: Connection to the successor EtherCAT device
		Flashing green	Act: Communication with the successor EtherCAT device

¹⁾ see following table

EtherCAT Run

The EtherCAT Run LEDs signal the current operating status of the EtherCAT devices.

Status	Operating status
Lights up	Operational
Flashes evenly	Pre-Operational
Flashes sporadically	Safe-Operational
Flashes very quickly	Boot
Off	Init

A description of the operating states can be found in the "EtherCAT | System Description": [Link](#).

3 Mounting and connection

3.1 Dimensions

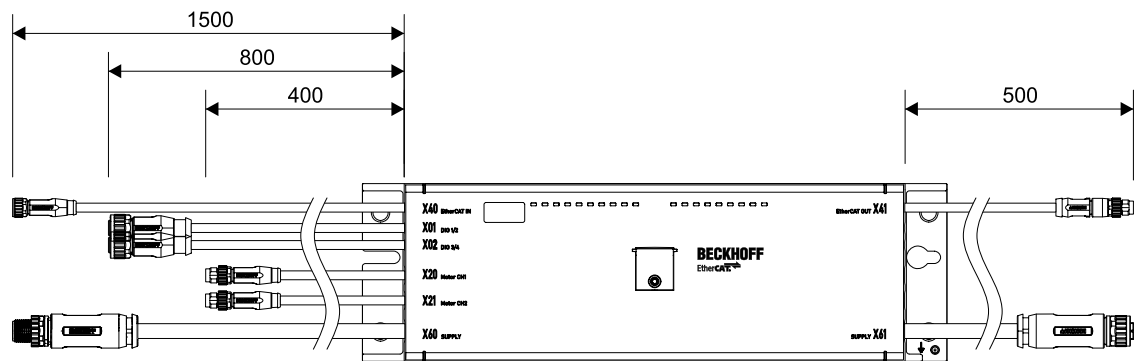

All dimensions are given in millimeters.
The drawing is not true to scale.

3.2 Mounting

NOTICE

Dirt during assembly

Dirty connectors can lead to malfunctions. The protection rating specified in the technical data is only guaranteed if all connectors are connected or closed with protective caps.

- Protect the connectors against dirt during the assembly.

Mount the module with two M6 screws in the mounting holes.

3.3 Functional earth

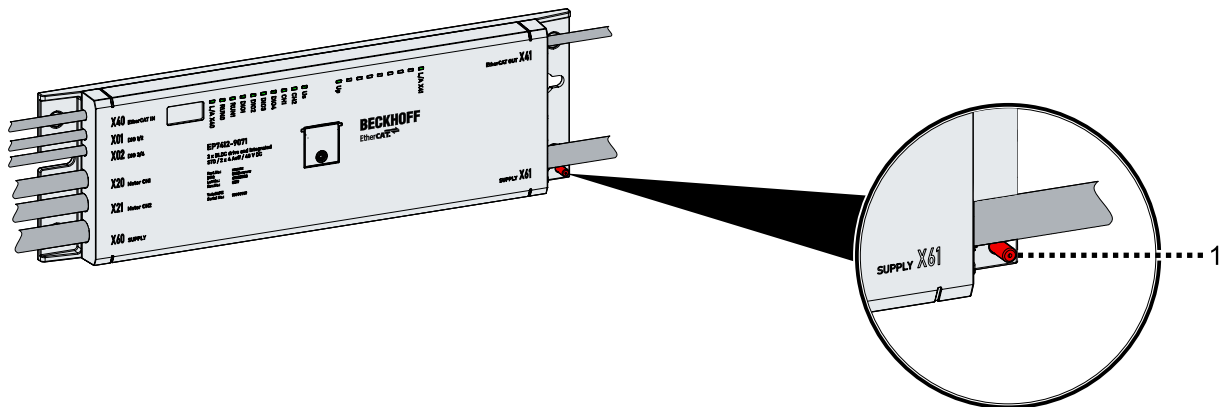

Ground the box with a low impedance via the grounding bolt [1].

3.4 Cabling

NOTICE

Damage caused by live wiring

Risk of defect.

- Only wire when de-energized.

3.4.1 EtherCAT

NOTICE

Risk of confusion with M8 connectors

The EtherCAT connections and motor connections have the same connector type and can be connected incorrectly by mistake. An incorrect connection can lead to defects.

- *Do not* connect EtherCAT connections and motor connections to each other.
- Note the cable colors: green for EtherCAT, black for motors



NOTICE

Use exclusively in EtherCAT networks

A connection of the EtherCAT connections to telecommunication networks can lead to network failure and data loss.

- Do not connect to telecommunications networks

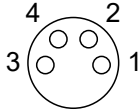
EtherCAT

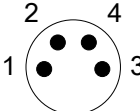
Input: M8 female socket		Pin	Function
		1	Tx+
		2	Rx+
		3	Rx-
		4	Tx-
Forwarding: M8 male plug		Pin	Function
		1	Tx+
		2	Rx+
		3	Rx-
		4	Tx-

3.4.2 Supply voltage input

⚠ WARNING

Power supply from SELV / PELV power supply unit!

SELV / PELV circuits (safety extra-low voltage / protective extra-low voltage) according to IEC 61010-2-201 must be used to supply this device.

Notes:

- SELV / PELV circuits may give rise to further requirements from standards such as IEC 60204-1 et al, for example with regard to cable spacing and insulation.
- A SELV supply provides safe electrical isolation and limitation of the voltage without a connection to the protective conductor, a PELV supply also requires a safe connection to the protective conductor.

⚠ CAUTION

Additional condition for UL operation

- Do not use unlimited voltage sources for the power supply

NOTICE

Special fuse protection required

Defect possible with insufficiently dimensioned fuse protection for the +48 V_{DC} U_P supply voltage.

- Dimension the fuse protection for the +48 V_{DC} U_P supply voltage so that the maximum current flow is limited to 3 times the rated current (max. 1 second).

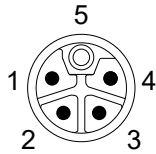
Input: M12 male plug		Pin	Function
		1	+24 V _{DC} U _S
		2	GND _P
		3	GND _S
		4	+48 V _{DC} U _P
		5	⏏

3.4.3 Supply voltage downstream connection

The supply voltages applied to the supply voltage input are available at the forwarding output for supplying other devices.

NOTICE

Risk of overload

Excessive output currents from the forwarding output can cause the maximum permissible input current at the supply voltage input to be exceeded.

- Ensure that the maximum input current of 16 A at the supply voltage input is not exceeded for either U_S or U_P

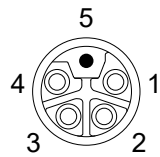
Forwarding: M12 female socket		Pin	Function
		1	+24 V _{DC} U _S
		2	GND _P
		3	GND _S
		4	+48 V _{DC} U _P
		5	⊥

3.4.4 Motor

NOTICE

Risk of confusion with M8 connectors

The EtherCAT connections and motor connections have the same connector type and can be connected incorrectly by mistake. An incorrect connection can lead to defects.

- *Do not* connect EtherCAT connections and motor connections to each other.
- Note the cable colors: green for EtherCAT, black for motors

Motor

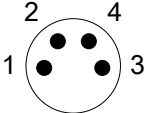
M8 male plug		Pin	Function
		1	GND _P
		2	Motor phase U
		3	Motor phase V
		4	Motor phase W

3.4.5 Digital I/O

NOTICE

Incorrect signal levels due to electromagnetic interference

The digital inputs are optimized for fast signal transmission and are therefore susceptible to electromagnetic interference.

Under the influence of electromagnetic interference, a false signal level can be detected.

- If necessary, use shielded signal lines.

I/O

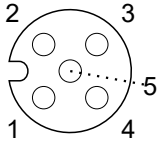
M12 female socket		Pin	Function
		1	$U_S = 24 V_{DC}$
		2	Input/Output B
		3	GND_S
		4	Input/Output A
		5	n.c.

3.5 Disposal



Products marked with a crossed-out wheeled bin shall not be discarded with the normal waste stream. The device is considered as waste electrical and electronic equipment. The national regulations for the disposal of waste electrical and electronic equipment must be observed.

4 Commissioning and configuration

4.1 Integrating into a TwinCAT project

The procedure for integration in a TwinCAT project is described in these [Quick start guide](#).

4.2 Quick start guide

This quick start guide describes the commissioning of the first motor channel in sensorless mode. The EP7412-9071 only supports sensorless operation, i.e. operation without external feedback.

For commissioning the second motor channel, you must add the offset 0x800 to all CoE indices. E.g. 0x2002 for channel 1 corresponds to 0x2802 for channel 2.

To ensure successful commissioning, carry out all the steps in the following chapters in the order given:

4.2.1 Parameterization



Enter alternating current data as peak values

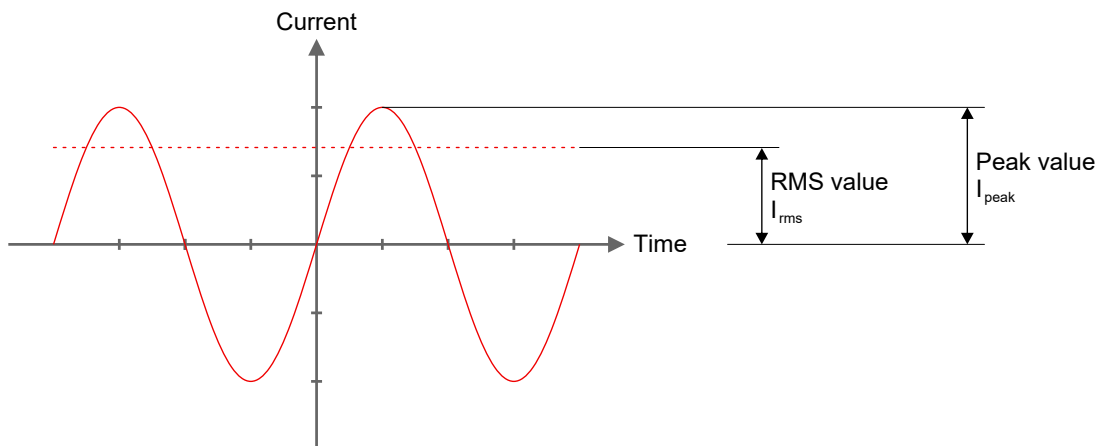

All alternating current data must be entered as peak values.

- If RMS values are specified in the motor data sheet, multiply them by $\sqrt{2}$ to convert them to a peak value.
 $4 A_{rms}$ must be converted to $5.657 A_{peak}$, for example.

Motor parameters

Set the following parameters according to the specifications in the motor data sheet:

- 0x6075:0 "Motor rated current Ch.1": rated current in [mA] as peak value
- 0x2003:11 "Max current": maximum current in [mA] as peak value
- 0x2003:2E "Rated speed" rated velocity in [rpm]
- 0x2003:13 "Motor pole pairs": the number of pole pairs of the motor

If the number of pole pairs of the motor is unknown, leave the parameter at the default value 1. The actual motor speed is then reduced by the factor "number of pole pairs" compared to the default.

After commissioning, you can determine the number of pole pairs experimentally, see chapter [Determine number of pole pairs](#) [► 30].

Further parameters

- 0x2002:64 set "Commutation type" to "Sensorless FOC with forced startup".
- DC link settings in CoE object 0xF800

NC scaling factors

- **Position values**

Default: $0x100000 = 1048576_{dec}$ increments = 1 revolution

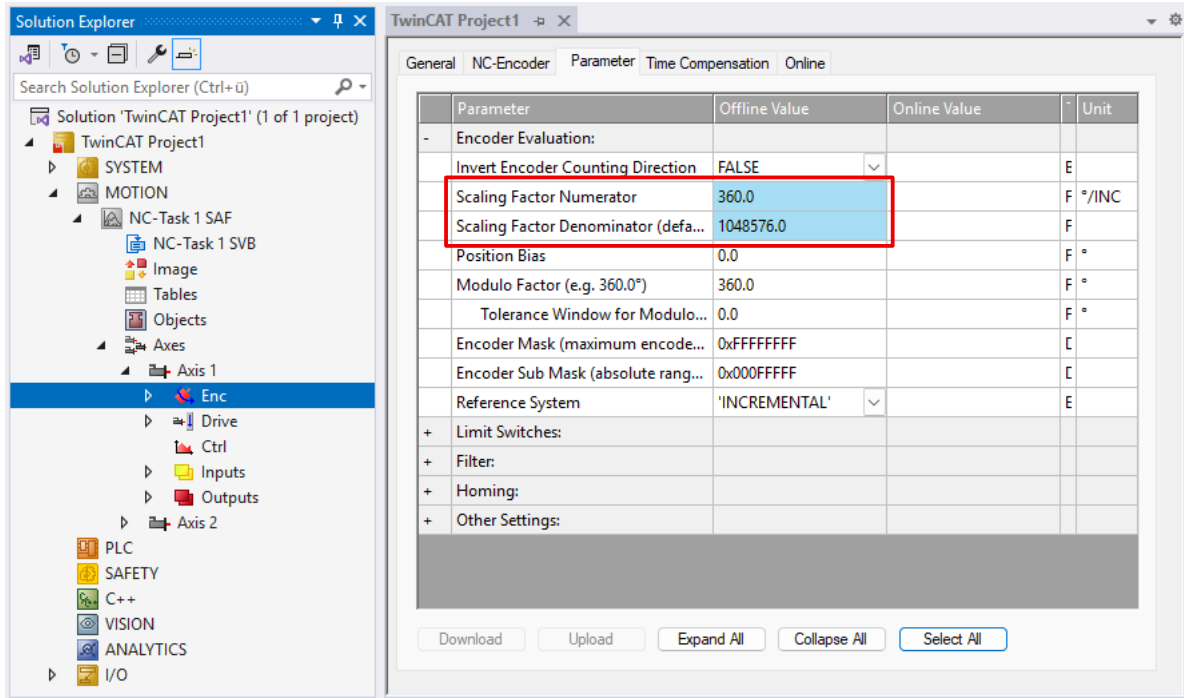

- **Velocity values**

Default: 268435 increments = 1 revolution

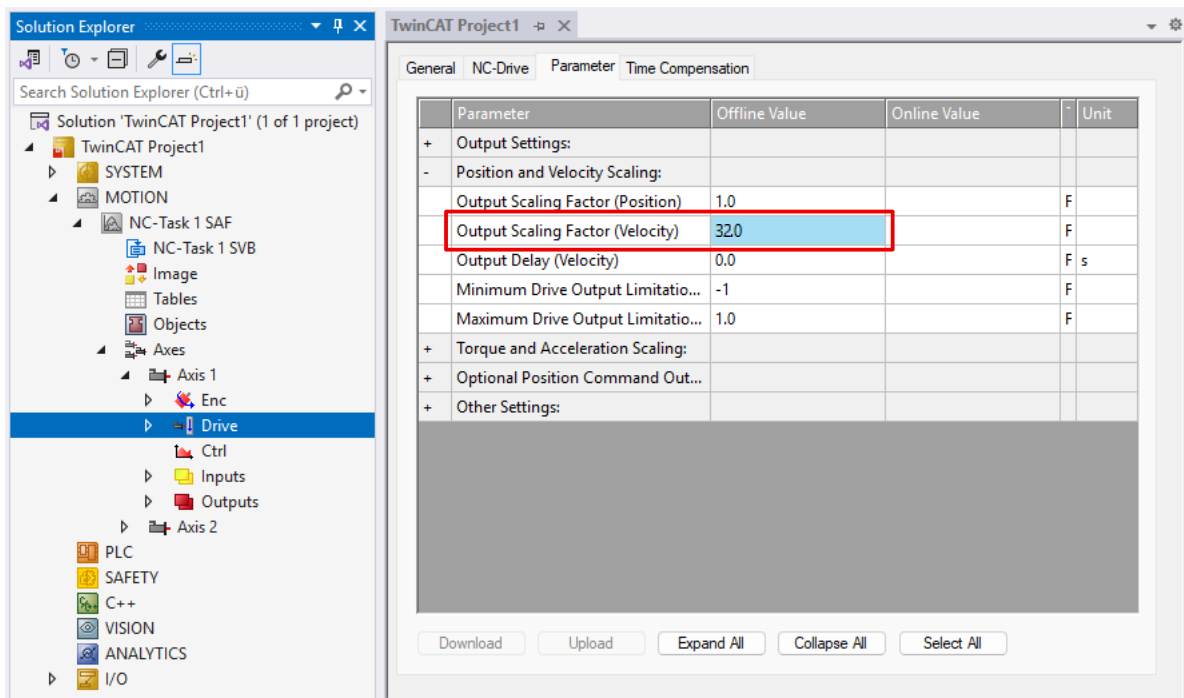

- **Torque values**

Default: 1000 increments = rated motor current

4.2.2 Prepare for operation

- Switch on the external supply voltage $U_P = 48\text{ V}_{DC}$
- Activate STO logic

4.2.3 Scan motor

⚠ CAUTION

The motor moves during scanning

The motor rotates in both directions by approx. 1 revolution each during scanning. Injuries and property damage are possible.

- Ensure that no one is harmed and nothing is damaged
- Ensure that the axis can move freely. Release brakes, clamping devices, etc.

You can perform the scan with or without a connected load. If you perform the scan with a connected load, the joint moment of inertia of the motor shaft and the load is measured when the parameter 0x2003:18 "Rotor moment of inertia" is measured.

✓ Prerequisite: all previous steps in this quick start guide have been carried out correctly.

1. If you have already enabled the axis, cancel the axis enable
2. For channel 1: Write the command 0x8007 to the register FB00:01 "Request".
For channel 2: Write the command 0x8017 to the register FB00:01 "Request".
⇒ The scan will be executed. It takes about one minute.
3. Monitor the status of the scan in parameter 0xFB00:02:

Value of 0xFB00:02 "Status"	Meaning
100 _{dec} ...200 _{dec}	Progress of the scan <ul style="list-style-type: none"> • 100 = 0% • 200 = 100%
0	The scan was successful
1...3	Error. See error message in the "Diag History"

If the scan was successful, the values determined are saved in the following CoE parameters:

- 0x2003:16 "Torque constant"
- 0x2003:18 "Rotor moment of inertia"
- 0x2003:19 "Winding inductance"
- 0x2003:2D "Motor thermal time constant"
- 0x2003:30 "Winding resistance"
- 0x2003:31 "Voltage constant"
- 0x2002:12 "Current loop integral time"
- 0x2002:13 "Current loop proportional gain"
- 0x2002:14 "Velocity loop integral time"
- 0x2002:15 "Velocity loop proportional gain"

4.2.4 Optimization, fine tuning

The axis is now ready for operation. You can move it for test purposes and optimize it with the following parameters:

- 0x2002:72 "Stand still torque limitation"
This parameter limits the holding current at standstill in order to reduce energy consumption and heating of the motor.
- 0x2002:79 "Sensorless Startup Current Scaling"
Scaling factor for the current that is driven during the start-up phase in sensorless mode. Is specified in 1/10 of the rated current, i.e. the value 1000 corresponds to 100% of the rated current. A higher value leads to a higher starting torque, but also to higher motor heating.
- Controller parameters:
 - 0x2002:14 "Velocity loop integral time"
 - 0x2002:15 "Velocity loop proportional gain"
 - 0x2002:17 "Position loop proportional gain"

4.3 Determine number of pole pairs

If the number of pole pairs of the motor is not specified in the data sheet, you can determine it experimentally.

Procedure

- ✓ Prerequisite: the motor has been configured in accordance with the chapter [Quick start guide \[▶ 25\]](#).
- 1. Ensure that the parameter 0x2003:13 "Motor pole pairs" has the value 1.
- 2. Send the request to the motor to perform a full rotation.
 - ⇒ The motor only performs a partial rotation because the number of pole pairs has not yet been set correctly.
- 3. Repeat the request until the motor has completed one full rotation.
 - ⇒ The number of requests needed for a full rotation corresponds to the number of pole pairs.
- 4. Enter the number of pole pairs in the parameter 0x2003:13 "Motor pole pairs".
- 5. Perform the scanning of the motor again: [Scan motor \[▶ 28\]](#)

4.4 Commissioning with Drive Motion Control

With Drive Motion Control you can implement a drive motion control without TwinCAT NC. One possible use case for Drive Motion Control is the operation of an EP7412-9071 on a small controller that does not have sufficient performance for the TwinCAT NC.

The documentation of the PLC library for Drive Motion Control can be found on the Beckhoff website: [Tc3_DriveMotionControl](#).

4.4.1 Requirements

TwinCAT 3.1, Build 4024.7 or higher.

4.4.2 Functionality

4.4.2.1 Supported functions

Administrative functions

- Axis functions
 - MC_Power
 - MC_Reset
 - MC_SetPosition
- Touch probe
 - MC_AbortTrigger
 - MC_TouchProbe

Motion functions

- Homing
 - MC_Home (Here the bCalibrationCam input of the Tc2_Mc2 library cannot be used, but one of the digital inputs of the EP7412-9071 must be used)
- Manual movement
 - MC_Jog
- Point to point movement
 - MC_Halt
 - MC_MoveAbsolute
 - MC_MoveModulo
 - MC_MoveRelative
 - MC_MoveVelocity
 - MC_Stop

4.4.2.2 Functions that are not supported

All subsequently triggered functions with the aim of changing the target position or speed during an active travel command are not supported (buffer mode).

4.4.3 Commissioning in TwinCAT 3

Use the following steps to configure channel 1 of a EP7412-9071 for operation with Drive Motion Control.

Configure channel 2 in the same way. The parameter indices for channel 2 are each increased by 0x0800 compared to channel 1.

1. Set the operation mode “Drive Motion Control (DMC)” in CoE parameter 0x6060 “Modes of operation”.

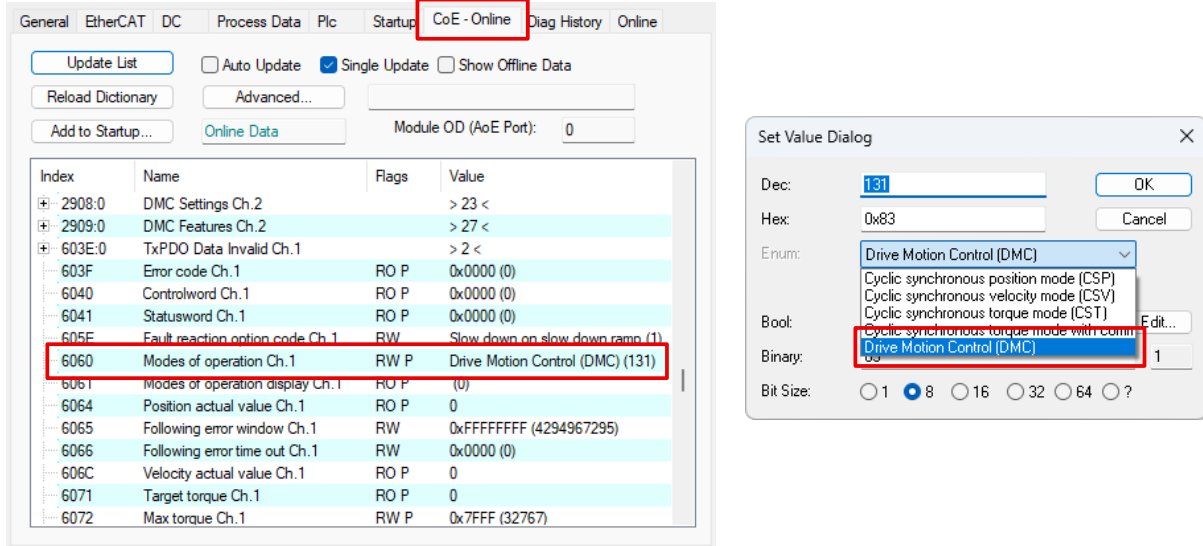

2. Activate the Predefined PDO Assignment “Drive motion control (For TC3 DriveMotionControl Lib)”.

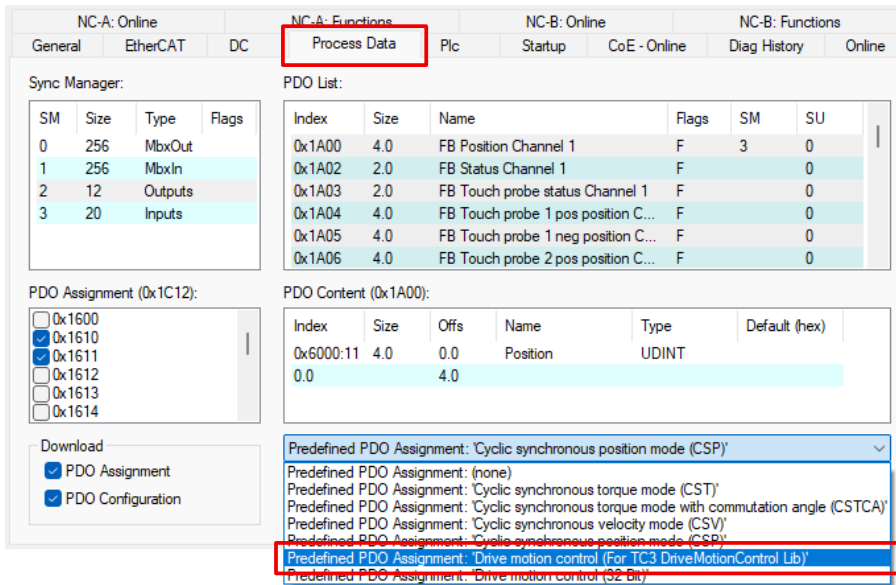

⇒ The process data for using Drive Motion Control is activated.

PLC configuration

1. Create a PLC project if none has been created yet.

2. Add the “Tc3_DriveMotionControl” library to the PLC project.
(If you want to use Drive Motion Control without the “Tc3_DriveMotionControl” library, see chapter [State machine \[▶ 38\]](#).)

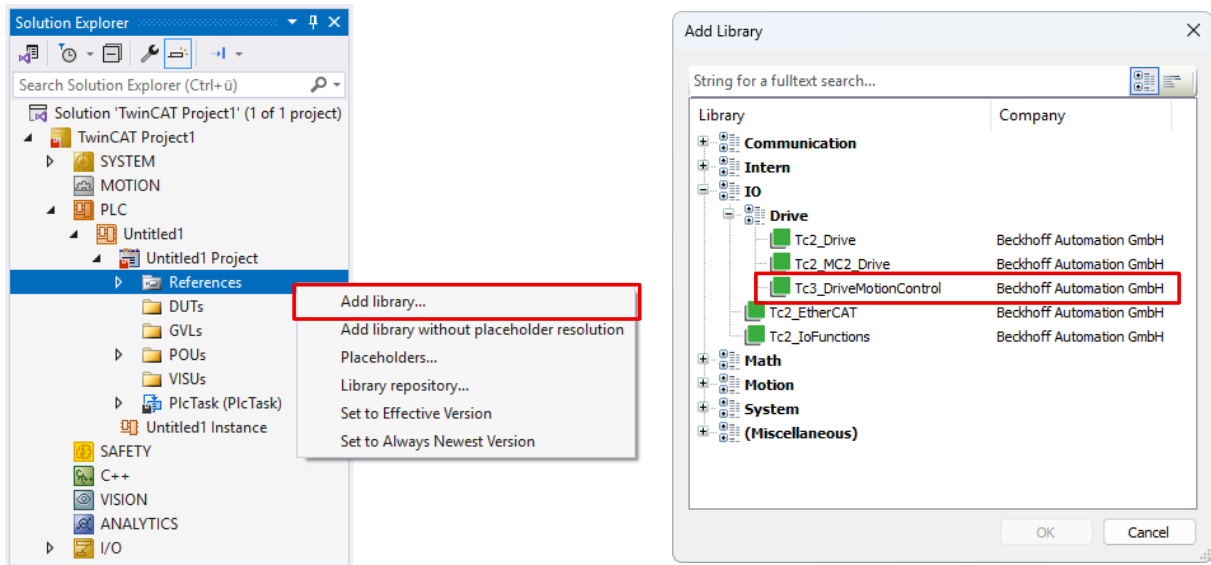

3. If the “Tc3_DriveMotionControl” and “Tc2_Mc2” libraries are used simultaneously in the current project: Set the “Qualified access only” property to “True” in the “Properties” window for one of the two libraries.

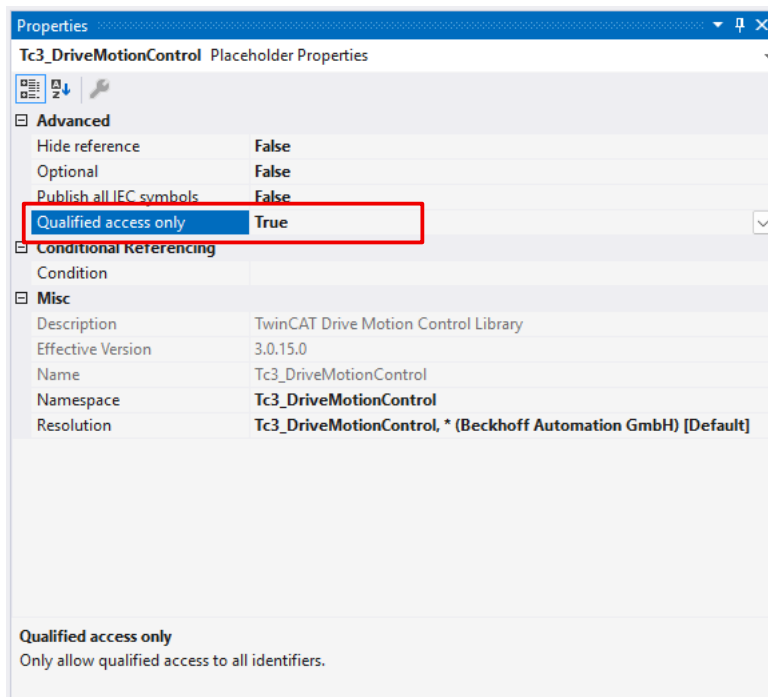

⇒ The library with “Qualified access only” can only be addressed in the PLC code via the corresponding namespace, e.g.: `Tc3_DriveMotionControl.MC_Stop()`
This avoids name conflicts, e.g. when calling the function block `MC_Stop`, which has the same name in both libraries.

4. Declare a variable of type “AXIS_REF” in the PLC. Sample:

```
VAR
    DmcAxis:    AXIS_REF;
END_VAR
```

5. Click on “Build’ > “Build Solution” in the menu bar.

⇒ The project is compiled.

⇒ The process image of the PLC task is generated.

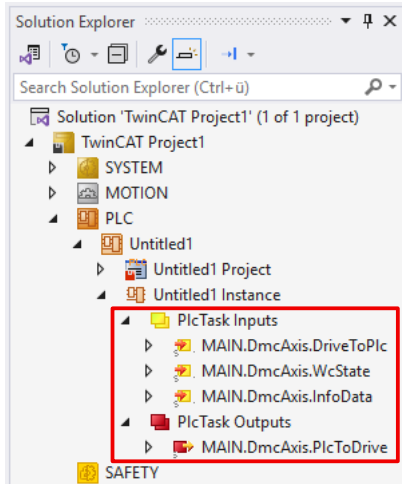

6. In the Solution Explorer link the PLC variables with the process data of EP7412-9071.

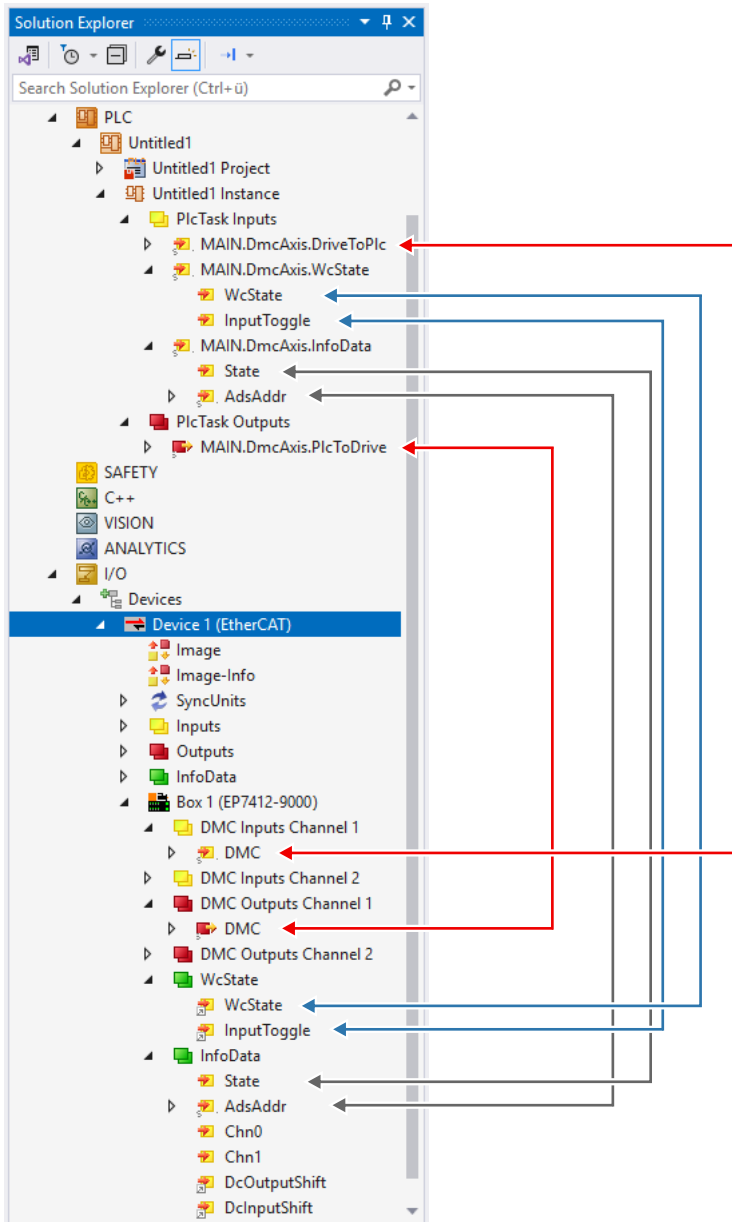

7. In the PLC code, call the function block `ReadStatus()` cyclically, ideally at the beginning of each PLC cycle.

4.4.3.1 Parameter

CoE parameters

The CoE parameters for configuring Drive Motion Control can be found in the following CoE objects:

- 0x2108 / 0x2908 [DMC Settings \[► 53\]](#)
- 0x2109 / 0x2908 [DMC Features \[► 53\]](#)

Scaling factor and maximum velocity

Position values are defined as 64-bit variables at Drive Motion Control.

The low-order 32 bits resolve the single-turn increments. The possibly lower resolution of the feedback is extrapolated to the full 32 bits.

The higher-order 32 bits represent the multi-turn revolutions.

The feed constant “Feed constant” includes any transmission ratios (gearbox, belt, etc.) and represents the output-side travel per motor revolution.

Therefore, the following exemplary formula without transmission ratio results for the scaling factor:

$$\text{Encoder Scaling Factor} = \frac{\text{Feed constant}}{32 \text{ Bit}} = \frac{360^\circ}{32 \text{ Bit}} \approx 8.3819031715393066e - 8$$

The maximum achievable velocity of the motor depends on the DC link voltage. If lower voltages than specified in the data sheet are used, the rated speed may have to be adjusted to the voltage. To specify the maximum velocity of the motor in the CoE directory, the object 0x6080 “Max motor speed” is also used. The DC link-dependent motor speed is specified here in 1/min. To adjust the velocity of the scaling, this value is multiplied by the feed constant and normalized to the unit second. This results in the following formula for the exemplary calculation of the maximum velocity:

$$\text{MaxVelocity} = \frac{\text{Max motor speed} \cdot \text{Feed constant}}{60 \frac{s}{min}} = \frac{1000 \frac{U}{min} \cdot 360^\circ}{60 \frac{s}{min}} = 6000 \frac{^\circ}{s}$$

The following sample shows the implementation in a PLC program:

```
PROGRAM MAIN
VAR
    DmcAxis:  AXIS_REF
END_VAR

// Update the axis structure
DmcAxis.ReadStatus();

// Scaling factor without gear ratio, feed constant 360°
DmcAxis.Parameter.EncoderScalingFactor := 0.000000083819031715393066;

// Velocity scaling with 1000 rpm, feed constant 360°
DmcAxis.Parameter.MaxVelocity := 6000;
```

4.4.4 Commissioning with a third-party 32-bit controller

The “Tc3_DriveMotionControl” library cannot be used.

i You can only execute travel commands by going through the state machine manually. See chapter [State machine](#) [▶ 38].

Since the box provides 64-bit process data by default, but this cannot be processed by some controllers, there is also the alternative option of mapping the process image with 32 bits. This can be set via the Predefined PDO Assignment “Drive motion control (32 Bit)”.

(To map the inputs and outputs manually, use the indices 0x1661 / 0x16E1 and 0x1A61 / 0x1AE1.)

All position related process data are 32-bit instead of 64-bit with this Predefined PDO Assignment. The 32 bits are divided into 20-bit single-turn and 12-bit multi-turn revolutions, independent of the resolution of the feedback.

The box still calculates internally with 64-bit data. Therefore, for example, 0x2108:08 “Calibration Position” must still be specified in 32-bit single-turn and 32-bit multi-turn instead of 20-bit single-turn and 12-bit multi-turn.

All non-position related process data remain unchanged in size. The address offsets of the individual process data are identical and padding bytes are inserted at the corresponding positions.

The velocity-related process data is scaled in 10,000ths of the parameter 0x6080 “Max motor speed”.

The process data for acceleration and deceleration specify in ms how fast the motor should accelerate to the speed specified in 0x6080 “Max motor speed” or decelerate from velocity to standstill. With a value of 2000 for the acceleration, the motor would need 2 s to reach the velocity.

Configuration

1. Set the operation mode “Drive Motion Control (DMC)” in CoE parameter 0x6060 “Modes of operation”.

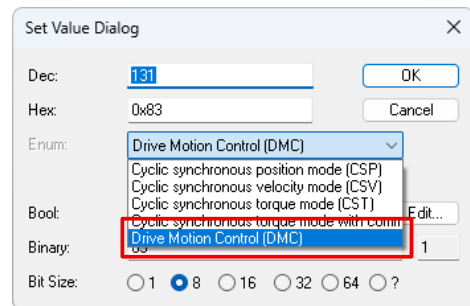
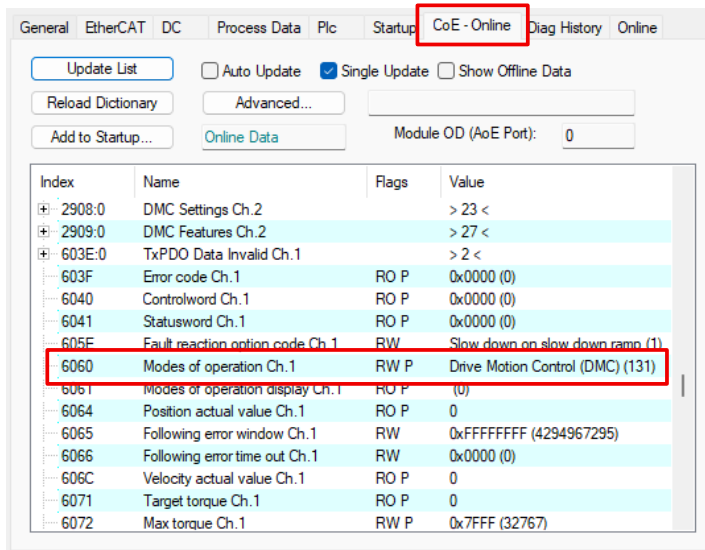

2. Activate the Predefined PDO Assignment “Drive motion control (32 Bit)”.

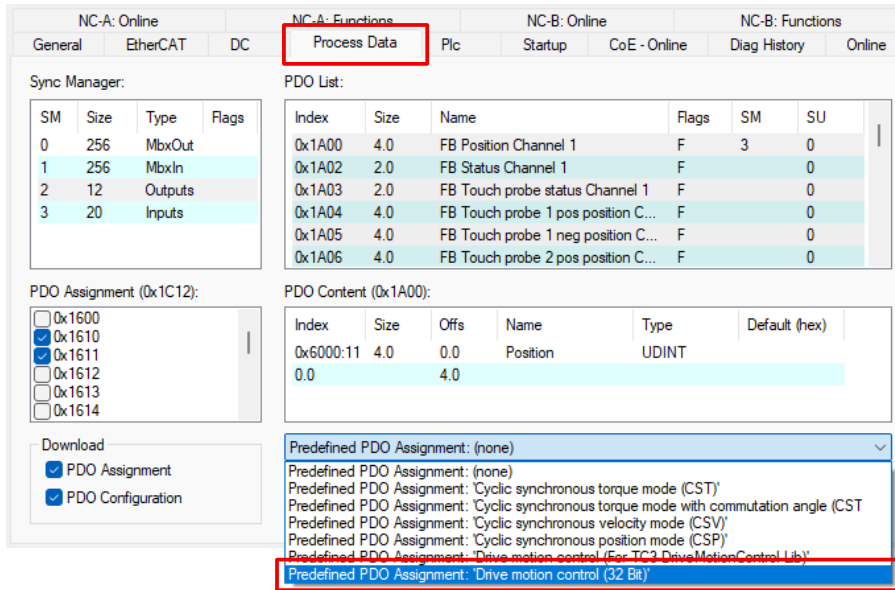

⇒ The process data for using Drive Motion Control is activated.

CoE parameters

The CoE parameters for configuring Drive Motion Control can be found in the following CoE objects:

- 0x2108 / 0x2908 [DMC Settings \[► 53\]](#)
- 0x2109 / 0x2908 [DMC Features \[► 53\]](#)

4.4.6 Differences compared with Tc2_Mc2

Tc2_Mc2 is the PLC library used for the operation of EP7412-9071 with TwinCAT NC.

The function blocks of the Tc3_DriveMotionControl library have a similar structure to that of Tc2_Mc2. However, Tc3_DriveMotionControl differs from Tc2_Mc2 in the following points:

- It is mandatory to specify values for the accelerations because there are no default values.
- “After-triggering functions” are not supported. Therefore there is no “BufferMode”.
- MC_Home has no input “bCalibrationCam”. The settings for homing are located in the CoE object 0x2109 / 0x2909 “DMC Features”.

4.4.7 Start types

Start type	Code	Description
ABSOLUTE	0x0001	Absolute positioning to a specified target position
RELATIVE	0x0002	Relative positioning to a calculated target position; a specified position difference is added to the current position
ENDLESS_PLUS	0x0003	Endless travel in the positive direction of rotation (direct specification of a speed)
ENDLESS_MINUS	0x0004	Endless travel in the negative direction of rotation (direct specification of a speed)
MODULO_SHORT	0x0105	Modulo positioning along the shortest path to the modulo position (positive or negative), calculated by the "Modulo factor"
MODULO_PLUS	0x0205	Modulo positioning in the positive direction of rotation to the calculated modulo position
MODULO_MINUS	0x0305	Modulo positioning in the negative direction of rotation to the calculated modulo position
CALI_PLC_CAM	0x6000	Start a calibration with cam (digital inputs)
CALI_ON_BLOCK	0x6200	Start a calibration "on Block"
CALI_SET_POS	0x6E00	Set as calibrated, do not change the position
CALI_CLEAR_POS	0x6F00	Clear calibration bit

4.4.8 Error messages

Error Code	Message
0x4420	Cogging compensation not supported
0x8450	Invalid Start Type 0x%x, "%x" replaced by the unsupported start type from the PDO
0x8451	Invalid limit switch level
0x8452	Drive error during positioning
0x8453	Latch unit will be used by multiple modules
0x8454	Drive not in control
0x8455	Invalid value for "Target acceleration"
0x8456	Invalid value for "Target deceleration"
0x8457	Invalid value for "Target velocity"
0x8458	Invalid value for "Target position"
0x8459	Emergency stop active
0x845A	Target position exceeds Modulofactor
0x845B	Drive must be disabled
0x845C	No feedback found
0x845D	Modulo factor invalid
0x845E	Invalid target position window

4.5 Restore the delivery state

You can restore the delivery state of the backup objects as follows:

1. Ensure that TwinCAT is running in Config mode.
2. In CoE object 1011:0 "Restore default parameters" select parameter 1011:01 "Subindex 001".

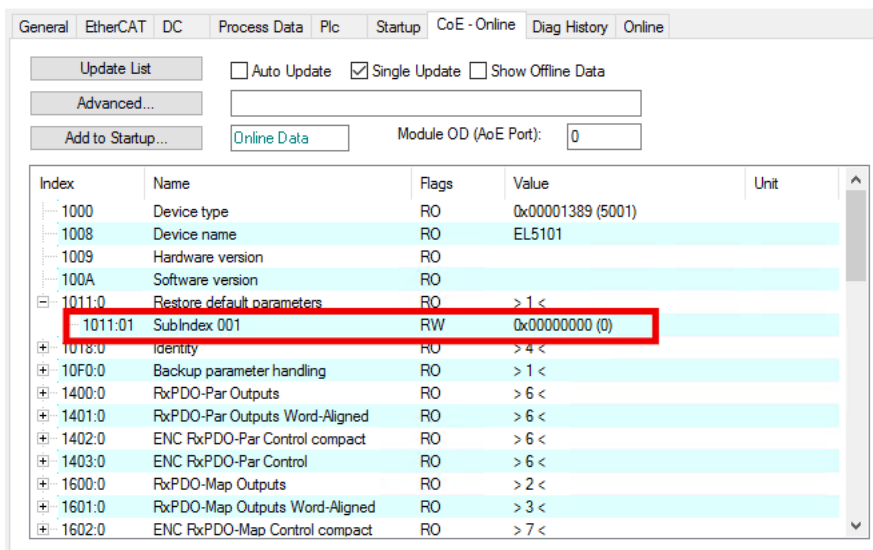

3. Double-click on "Subindex 001".
⇒ The "Set Value Dialog" dialog box opens.
4. Enter the value 1684107116 in the "Dec" field.
Alternatively: enter the value 0x64616F6C in the "Hex" field.

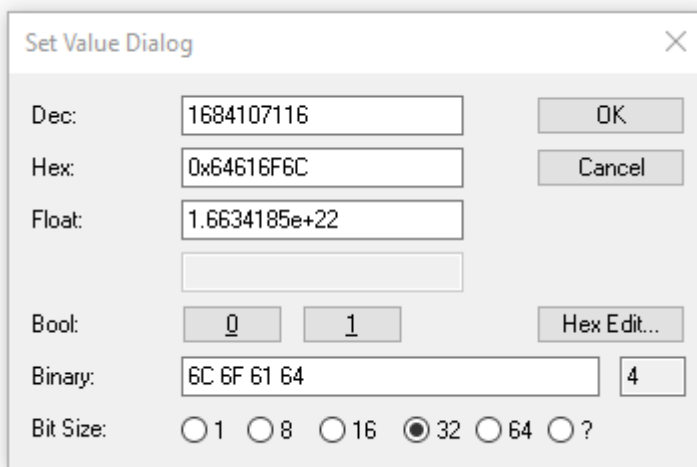

5. Confirm with "OK".
⇒ All backup objects are reset to the delivery state.

Alternative restore value

With some older modules the backup objects can be changed with an alternative restore value:

Decimal value: 1819238756

Hexadecimal value: 0x6C6F6164

An incorrect entry for the restore value has no effect.

5 CoE parameters

Index (hex)	Name
1000	Device type [▶ 70]
1001	Error register [▶ 70]
1008	Device name [▶ 70]
1009	Hardware version [▶ 70]
100A	Software version [▶ 70]
100B	Bootloader version [▶ 70]
1011	Restore default parameters [▶ 70]
1018	Identity [▶ 70]
1020	Device Statistics [▶ 71]
10E2	Manufacturer-specific Identification Code [▶ 71]
10F0	Backup parameter handling [▶ 71]
10F3	Diagnosis History [▶ 71]
10F8	Timestamp Object [▶ 71]
1460	DS402 RxPDO-Par Outputs Ch.1 [▶ 72]
1461	DS402 RxPDO-Par Outputs 32 Bit Ch.1 [▶ 72]
14E0	DS402 RxPDO-Par Outputs Ch.2 [▶ 72]
14E1	DS402 RxPDO-Par Outputs 32 Bit Ch.2 [▶ 72]
1600	DS402 RxPDO-Map Controlword Ch.1 [▶ 72]
1601	DS402 RxPDO-Map Target velocity Ch.1 [▶ 72]
1602	DS402 RxPDO-Map Target torque Ch.1 [▶ 72]
1603	DS402 RxPDO-Map Commutation angle Ch.1 [▶ 73]
1604	DS402 RxPDO-Map Torque limitation Ch.1 [▶ 73]
1605	DS402 RxPDO-Map Torque offset Ch.1 [▶ 73]
1606	DS402 RxPDO-Map Target position Ch.1 [▶ 73]
1607	DS402 RxPDO-Map Touch probe function Ch.1 [▶ 73]
1608	DS402 RxPDO-Map Modes of operation Ch.1 [▶ 73]
1609	DS402 RxPDO-Map Velocity offset Ch.1 [▶ 73]
160A	DS402 RxPDO-Map Positive Torque limit value Ch.1 [▶ 73]
160B	DS402 RxPDO-Map Negative Torque limit value Ch.1 [▶ 74]
1610	DS402 RxPDO-Map Digital Outputs Ch.1 [▶ 74]
1660	DS402 RxPDO-Map Outputs Ch.1 [▶ 74]
1661	DS402 RxPDO-Map Outputs 32 Bit Ch.1 [▶ 75]
1670	DS402 RxPDO-Map Dynamic Outputs Ch.1 [▶ 75]
1680	DS402 RxPDO-Map Controlword Ch.2 [▶ 75]
1681	DS402 RxPDO-Map Target velocity Ch.2 [▶ 75]
1682	DS402 RxPDO-Map Target torque Ch.2 [▶ 76]
1683	DS402 RxPDO-Map Commutation angle Ch.2 [▶ 76]
1684	DS402 RxPDO-Map Torque limitation Ch.2 [▶ 76]
1685	DS402 RxPDO-Map Torque offset Ch.2 [▶ 76]
1686	DS402 RxPDO-Map Target position Ch.2 [▶ 76]
1687	DS402 RxPDO-Map Touch probe function Ch.2 [▶ 76]
1688	DS402 RxPDO-Map Modes of operation Ch.2 [▶ 76]
1689	DS402 RxPDO-Map Velocity offset Ch.2 [▶ 76]
168A	DS402 RxPDO-Map Positive Torque limit value Ch.2 [▶ 77]
168B	DS402 RxPDO-Map Negative Torque limit value Ch.2 [▶ 77]
1690	DS402 RxPDO-Map Digital Outputs Ch.2 [▶ 77]
16E0	DS402 RxPDO-Map Outputs Ch.2 [▶ 77]
16E1	DS402 RxPDO-Map Outputs 32 Bit Ch.2 [▶ 78]
16F0	DS402 RxPDO-Map Dynamic Outputs Ch.2 [▶ 78]

Index (hex)	Name
1860	DS402 TxPDO-Par Inputs Ch.1 [▶ 78]
1861	DS402 TxPDO-Par Inputs 32 Bit Ch.1 [▶ 79]
18E0	DS402 TxPDO-Par Inputs Ch.2 [▶ 79]
18E1	DS402 TxPDO-Par Inputs 32 Bit Ch.2 [▶ 79]
1A00	DS402 TxPDO-Map Position actual value Ch.1 [▶ 79]
1A01	DS402 TxPDO-Map Statusword Ch.1 [▶ 79]
1A02	DS402 TxPDO-Map Velocity actual value Ch.1 [▶ 79]
1A03	DS402 TxPDO-Map Torque actual value Ch.1 [▶ 79]
1A04	DS402 TxPDO-Map Info data 1 Ch.1 [▶ 80]
1A05	DS402 TxPDO-Map Info data 2 Ch.1 [▶ 80]
1A06	DS402 TxPDO-Map Following error actual value Ch.1 [▶ 80]
1A07	DS402 TxPDO-Map Touch probe status Ch.1 [▶ 80]
1A08	DS402 TxPDO-Map Touch probe 1 positive edge Ch.1 [▶ 81]
1A09	DS402 TxPDO-Map Touch probe 1 negative edge Ch.1 [▶ 81]
1A0A	DS402 TxPDO-Map Touch probe 2 positive edge Ch.1 [▶ 81]
1A0B	DS402 TxPDO-Map Touch probe 2 negative edge Ch.1 [▶ 81]
1A0C	DS402 TxPDO-Map TxPDO Data Invalid Ch.1 [▶ 81]
1A0D	DS402 TxPDO-Map Info data 3 Ch.1 [▶ 81]
1A0E	DS402 TxPDO-Map Modes of operation display Ch.1 [▶ 82]
1A10	DS402 TxPDO-Map Digital Inputs Ch.1 [▶ 82]
1A11	DS402 TxPDO-Map Touch probe time stamp 1 positive value Ch.1 [▶ 82]
1A12	DS402 TxPDO-Map Touch probe time stamp 1 negative value Ch.1 [▶ 82]
1A13	DS402 TxPDO-Map Touch probe time stamp 2 positive value Ch.1 [▶ 82]
1A14	DS402 TxPDO-Map Touch probe time stamp 2 negative value Ch.1 [▶ 82]
1A60	DS402 TxPDO-Map Inputs Ch.1 [▶ 83]
1A61	DS402 TxPDO-Map Inputs 32 Bit Ch.1 [▶ 84]
1A70	DS402 TxPDO-Map Dynamic Inputs Ch.1 [▶ 85]
1A80	DS402 TxPDO-Map Position actual value Ch.2 [▶ 85]
1A81	DS402 TxPDO-Map Statusword Ch.2 [▶ 85]
1A82	DS402 TxPDO-Map Velocity actual value Ch.2 [▶ 85]
1A83	DS402 TxPDO-Map Torque actual value Ch.2 [▶ 85]
1A84	DS402 TxPDO-Map Info data 1 Ch.2 [▶ 86]
1A85	DS402 TxPDO-Map Info data 2 Ch.2 [▶ 86]
1A86	DS402 TxPDO-Map Following error actual value Ch.2 [▶ 86]
1A87	DS402 TxPDO-Map Touch probe status Ch.2 [▶ 86]
1A88	DS402 TxPDO-Map Touch probe 1 positive edge Ch.2 [▶ 87]
1A89	DS402 TxPDO-Map Touch probe 1 negative edge Ch.2 [▶ 87]
1A8A	DS402 TxPDO-Map Touch probe 2 positive edge Ch.2 [▶ 87]
1A8B	DS402 TxPDO-Map Touch probe 2 negative edge Ch.2 [▶ 87]
1A8C	DS402 TxPDO-Map TxPDO Data Invalid Ch.2 [▶ 87]
1A8D	DS402 TxPDO-Map Info data 3 Ch.2 [▶ 87]
1A8E	DS402 TxPDO-Map Modes of operation display Ch.2 [▶ 88]
1A90	DS402 TxPDO-Map Digital Inputs Ch.2 [▶ 88]
1A91	DS402 TxPDO-Map Touch probe time stamp 1 positive value Ch.2 [▶ 88]
1A92	DS402 TxPDO-Map Touch probe time stamp 1 negative value Ch.2 [▶ 88]
1A93	DS402 TxPDO-Map Touch probe time stamp 2 positive value Ch.2 [▶ 88]
1A94	DS402 TxPDO-Map Touch probe time stamp 2 negative value Ch.2 [▶ 88]
1AE0	DS402 TxPDO-Map Inputs Ch.2 [▶ 89]
1AE1	DS402 TxPDO-Map Inputs 32 Bit Ch.2 [▶ 90]
1AF0	DS402 TxPDO-Map Dynamic Inputs Ch.2 [▶ 91]
1C00	Sync manager type [▶ 91]
1C12	RxPDO assign [▶ 92]

Index (hex)	Name
1C13	TxPDO assign [▶ 93]
1C14	Dynamic RxPDO assign [▶ 93]
1C15	Dynamic TxPDO assign [▶ 94]
1C32	SM output parameter [▶ 94]
1C33	SM input parameter [▶ 94]
2002	Amplifier Settings Ch.1 [▶ 46]
2003	Motor Settings Ch.1 [▶ 48]
2004	Brake Settings Ch.1 [▶ 49]
2005	Filter Settings Ch.1 [▶ 50]
2008	Inputs Ch.1 [▶ 57]
200A	Digital Output Settings Ch.1 [▶ 50]
200B	Remote Outputs Ch.1 [▶ 57]
2010	Feedback Settings Ch.1 [▶ 51]
2020	Vendor data Ch.1 [▶ 52]
2030	Amplifier Diag data Ch.1 [▶ 55]
2031	Motor Diag data Ch.1 [▶ 55]
2040	Amplifier Info data Ch.1 [▶ 55]
2042	Cycle Times Ch.1 [▶ 56]
205A	Feedback Info Data Ch.1 [▶ 56]
2100	DMC Inputs Ch.1 [▶ 58]
2104	DMC Outputs Ch.1 [▶ 60]
2108	DMC Settings Ch.1 [▶ 53]
2109	DMC Features Ch.1 [▶ 53]
2802	Amplifier Settings Ch.2 [▶ 46]
2803	Motor Settings Ch.2 [▶ 48]
2804	Brake Settings Ch.2 [▶ 49]
2805	Filter Settings Ch.2 [▶ 50]
2808	Inputs Ch.2 [▶ 57]
280A	Digital Output Settings Ch.2 [▶ 50]
280B	Remote Outputs Ch.2 [▶ 57]
2810	Feedback Settings Ch.2 [▶ 51]
2820	Vendor data Ch.2 [▶ 52]
2830	Amplifier Diag data Ch.2 [▶ 55]
2831	Motor Diag data Ch.2 [▶ 55]
2840	Amplifier Info data Ch.2 [▶ 55]
2842	Cycle Times Ch.2 [▶ 56]
285A	Feedback Info Data Ch.2 [▶ 56]
2900	DMC Inputs Ch.2 [▶ 58]
2904	DMC Outputs Ch.2 [▶ 60]
2908	DMC Settings Ch.2 [▶ 53]
2909	DMC Features Ch.2 [▶ 53]
603E	TxPDO Data Invalid Ch.1 [▶ 60]
603F	Error code Ch.1 [▶ 61]
6040	Controlword Ch.1 [▶ 61]
6041	Statusword Ch.1 [▶ 61]
605E	Fault reaction option code Ch.1 [▶ 61]
6060	Modes of operation Ch.1 [▶ 62]
6061	Modes of operation display Ch.1 [▶ 62]
6064	Position actual value Ch.1 [▶ 62]
6065	Following error window Ch.1 [▶ 62]
6066	Following error time out Ch.1 [▶ 63]
606C	Velocity actual value Ch.1 [▶ 63]

Index (hex)	Name
6071	Target torque Ch.1 [▶ 63]
6072	Max torque Ch.1 [▶ 63]
6075	Motor rated current Ch.1 [▶ 64]
6077	Torque actual value Ch.1 [▶ 64]
6079	DC link circuit voltage Ch.1 [▶ 64]
607A	Target position Ch.1 [▶ 64]
607B	Position range limit Ch.1 [▶ 63]
607E	Polarity Ch.1 [▶ 64]
6080	Max motor speed Ch.1 [▶ 64]
6091	Gear ratio Ch.1 [▶ 65]
60B1	Velocity offset Ch.1 [▶ 65]
60B2	Torque offset Ch.1 [▶ 65]
60B8	Touch probe function Ch.1 [▶ 66]
60B9	Touch probe status Ch.1 [▶ 66]
60BA	Touch probe 1 positive edge Ch.1 [▶ 66]
60BB	Touch probe 1 negative edge Ch.1 [▶ 66]
60BC	Touch probe 2 positive edge Ch.1 [▶ 67]
60BD	Touch probe 2 negative edge Ch.1 [▶ 67]
60D0	Touch probe source Ch.1 [▶ 67]
60D1	Touch probe time stamp 1 positive value Ch.1 [▶ 67]
60D2	Touch probe time stamp 1 negative value Ch.1 [▶ 67]
60D3	Touch probe time stamp 2 positive value Ch.1 [▶ 67]
60D4	Touch probe time stamp 2 negative value Ch.1 [▶ 67]
60D9	Supported synchronization functions Ch.1 [▶ 68]
60DA	Synchronization function settings Ch.1 [▶ 68]
60E0	Positive torque limit value Ch.1 [▶ 68]
60E1	Negative torque limit value Ch.1 [▶ 68]
60EA	Commutation angle Ch.1 [▶ 68]
60F4	Following error actual value Ch.1 [▶ 69]
60FD	Digital Inputs Ch.1 [▶ 69]
60FE	Digital Outputs Ch.1 [▶ 69]
60FF	Target velocity Ch.1 [▶ 69]
6502	Supported drive modes Ch.1 [▶ 69]
683E	TxPDO Data Invalid Ch.2 [▶ 60]
683F	Error code Ch.2 [▶ 61]
6840	Controlword Ch.2 [▶ 61]
6841	Statusword Ch.2 [▶ 61]
685E	Fault reaction option code Ch.2 [▶ 61]
6860	Modes of operation Ch.2 [▶ 62]
6861	Modes of operation display Ch.2 [▶ 62]
6864	Position actual value Ch.2 [▶ 62]
6865	Following error window Ch.2 [▶ 62]
6866	Following error time out Ch.2 [▶ 63]
686C	Velocity actual value Ch.2 [▶ 63]
6871	Target torque Ch.2 [▶ 63]
6872	Max torque Ch.2 [▶ 63]
6875	Motor rated current Ch.2 [▶ 64]
6877	Torque actual value Ch.2 [▶ 64]
6879	DC link circuit voltage Ch.2 [▶ 64]
687A	Target position Ch.2 [▶ 64]
687B	Position range limit Ch.2 [▶ 63]
687E	Polarity Ch.2 [▶ 64]

Index (hex)	Name
6880	Max motor speed Ch.2 [▶ 64]
6891	Gear ratio Ch.2 [▶ 65]
68B1	Velocity offset Ch.2 [▶ 65]
68B2	Torque offset Ch.2 [▶ 65]
68B8	Touch probe function Ch.2 [▶ 66]
68B9	Touch probe status Ch.2 [▶ 66]
68BA	Touch probe 1 positive edge Ch.2 [▶ 66]
68BB	Touch probe 1 negative edge Ch.2 [▶ 66]
68BC	Touch probe 2 positive edge Ch.2 [▶ 67]
68BD	Touch probe 2 negative edge Ch.2 [▶ 67]
68D0	Touch probe source Ch.2 [▶ 67]
68D1	Touch probe time stamp 1 positive value Ch.2 [▶ 67]
68D2	Touch probe time stamp 1 negative value Ch.2 [▶ 67]
68D3	Touch probe time stamp 2 positive value Ch.2 [▶ 67]
68D4	Touch probe time stamp 2 negative value Ch.2 [▶ 67]
68D9	Supported synchronization functions Ch.2 [▶ 68]
68DA	Synchronization function settings Ch.2 [▶ 68]
68E0	Positive torque limit value Ch.2 [▶ 68]
68E1	Negative torque limit value Ch.2 [▶ 68]
68EA	Commutation angle Ch.2 [▶ 68]
68F4	Following error actual value Ch.2 [▶ 69]
68FD	Digital Inputs Ch.2 [▶ 69]
68FE	Digital Outputs Ch.2 [▶ 69]
68FF	Target velocity Ch.2 [▶ 69]
6D02	Supported drive modes Ch.2 [▶ 69]
F008	Code word [▶ 94]
F081	Download revision [▶ 95]
F800	DRV Amplifier Settings [▶ 54]
F900	DRV Info data [▶ 56]
F913	DRV Device Info data [▶ 56]
FB00	Command [▶ 95]
FB13	DRV Key code [▶ 95]
FB40	Memory interface [▶ 95]

5.1 Configuration objects

Index 2n02 Amplifier Settings Ch.x

- Index 2002: Amplifier Settings Ch.1
- Index 2802: Amplifier Settings Ch.2

Subindex (hex)	Name	Meaning	Data Type	Flags	Default
0	Amplifier Settings Ch.x		USINT	RO	0x7A (122 _{dec})
12	Current loop integral time	Integral component of current controller. Unit: [0.1 ms]	UINT	RW	0xA (10 _{dec})
13	Current loop proportional gain	Proportional component of current controller. Unit: [0.1 V/A]	UINT	RW	0x64 (100 _{dec})
14	Velocity loop integral time	Integral component of velocity controller. Unit: [0.1 ms]	UDINT	RW	0x96 (150 _{dec})
15	Velocity loop proportional gain	Proportional component of velocity controller. Unit: [mA / (rad/s)]	UDINT	RW	0x14 (20 _{dec})
17	Position loop proportional gain	Proportional component position controller. Unit: [(rad/s) / rad]	UDINT	RW	0xA (10 _{dec})
29	Amplifier I2T warn level	I ² T model warning threshold. Unit: [%]	USINT	RW	0x50 (80 _{dec})
2A	Amplifier I2T error level	I ² T model error threshold. Unit: [%]	USINT	RW	0x69 (105 _{dec})
31	Velocity limitation	Velocity limitation. If a gear ratio is configured (parameter 6091/6891), this limit value refers to the load side. Unit: [1/min]	UDINT	RW	0x186A0 (100000 _{dec})
32	Short circuit brake duration max	Maximum holding time for anchor short-circuit braking Unit: [ms]	UINT	RW	0x3E8 (1000 _{dec})
33	Stand still window	Standstill window Unit: [1/min]	UINT	RW	0x1 (1 _{dec})
49	Halt ramp deceleration	Halt ramp deceleration. Unit: [0.1 rad / s ²]	UDINT	RW	0xF570 (62832 _{dec})
54	Feature bits	Reserved. Please do not change.	UDINT	RW	0x0 (0 _{dec})
55	Select info data 1	Possible values: <ul style="list-style-type: none"> • 2_{dec}: DC link voltage (mV) • 4_{dec}: PCB temperature (0.1 °C) • 7_{dec}: I2T Motor • 8_{dec}: I2T Amplifier • 10_{dec}: Digital inputs 	USINT	RW	0x2 (2 _{dec})
56	Select info data 2	Possible values: <ul style="list-style-type: none"> • 2_{dec}: DC link voltage (mV) • 4_{dec}: PCB temperature (0.1 °C) • 7_{dec}: I2T Motor • 8_{dec}: I2T Amplifier • 10_{dec}: Digital inputs 	USINT	RW	0x4 (4 _{dec})
57	Velocity feed forward gain	Scaling factor for velocity feedforward from the position interpolator.	USINT	RW	0x64 (100 _{dec})
58	Select info data 3	Possible values: <ul style="list-style-type: none"> • 2_{dec}: DC link voltage (mV) • 4_{dec}: PCB temperature (0.1 °C) • 7_{dec}: I2T Motor • 8_{dec}: I2T Amplifier • 10_{dec}: Digital inputs 	USINT	RW	0x7 (7 _{dec})
59	Error suppression mask	Reserved. Please do not change.	UDINT	RW	0x0 (0 _{dec})

Subindex (hex)	Name	Meaning	Data Type	Flags	Default
5F	Sensorless observer bandwidth	Observer bandwidth for sensorless control Unit: [Hz]	UINT	RW	0xC8 (200 _{dec})
62	Position loop deadband window	Deadband window of the position controller Unit: [increments]	UDINT	RW	0x0 (0 _{dec})
64	Commutation type	Possible values: • 5 _{dec} : Sensorless FOC with forced startup	USINT	RW	0x5 (5 _{dec})
6D	Torque feed forward gain	Internal torque feedforward: scaling factor	UDINT	RW	0x0 (0 _{dec})
6E	Torque feed forward filter time	Internal torque feedforward: filter time. Unit: [0.1 ms]	UDINT	RW	0xA (10 _{dec})
71	Error Code Options	Choice of diagnostic messages that are displayed in 0x6n3F "Error code" (PDO mapping possible) Possible values: • 1 _{dec} : Display Errors • 3 _{dec} : Display Errors Warnings • 7 _{dec} : Display Errors Warnings Infos	USINT	RW	0x7 (7 _{dec})
72	Stand still torque limitation	Output standstill holding current for sensorless control	UINT	RW	0x1F4 (500 _{dec})
73	Acceleration limitation	Maximum acceleration (setpoint limit) Unit: [0.1 rad/s ²]	UDINT	RW	0xF570 (62832 _{dec})
79	Sensorless Startup Current Scaling	Motor starting current for sensorless control. The current configured here is output at low speeds ("forced startup" phase). Specified in parts per thousand of the rated motor current. I.e. 1000 = rated motor current	UINT	RW	0x2EE (750 _{dec})
7A	Sensorless Stall Reaction	Reaction to a detected commutation error (Motor Stall) in sensorless control. Possible values: • 0 _{dec} : Stop motor with drive error • 1 _{dec} : Restart motor • 255 _{dec} : Disable Stall Monitoring	USINT	RW	0x0 (0 _{dec})

Index 2n03 Motor Settings Ch.x

- Index 2003: Motor Settings Ch.1
- Index 2803: Motor Settings Ch.2

Subindex (hex)	Name	Meaning	Data type	Flags	Default
0	Motor Settings Ch.x		USINT	RO	0x34 (52 _{dec})
11	Max current	Peak current Unit: [mA]	UDINT	RW	0x445C (17500 _{dec})
13	Motor pole pairs	Number of pole pairs	USINT	RW	0x1 (1 _{dec})
16	Torque constant	Torque constant Unit: [mNm/A]	UDINT	RW	0x12C (300 _{dec})
18	Rotor moment of inertia	Motor moment of inertia Unit: [g cm ²]	UDINT	RW	0x1EF (495 _{dec})
19	Winding inductance	Winding inductance Unit: [0.1 mH]	UINT	RW	0x186 (390 _{dec})
29	Motor I ² T warn level	I ² t model warning threshold Unit: [%]	USINT	RW	0x50 (80 _{dec})
2A	Motor I ² T error level	I ² t model error threshold Unit: [%]	USINT	RW	0x69 (105 _{dec})
2D	Motor thermal time constant	Thermal time constant Unit: [0.1 s]	UINT	RW	0x28 (40 _{dec})
2E	Rated speed	Rated speed Unit: [rpm]	UDINT	RW	0x3E8 (1000 _{dec})
30	Winding resistance	Winding resistance Unit: [mOhm]	UDINT	RW	0x578 (1400 _{dec})
31	Voltage constant	Motor back-EMF voltage constant Unit: [μV/(1/min)]	UDINT	RW	0x4E20 (20000 _{dec})
34	Configured motor current	Limits the output current. (The output current is limited to the lower of "Rated current" and "Configured motor current".) This parameter allows you to prevent the channel from drawing a disproportionately large share of the available U _p total current relative to the other channels.	UDINT	RW	0x1618 (5656 _{dec})

2n04 Brake Settings Ch.x

- Index 2004: Brake Settings Ch.1
- Index 2804: Brake Settings Ch.2

Subindex (hex)	Name	Meaning	Data Type	Flags	Default
0	Brake Settings Ch.x		USINT	RO	0x18 (24 _{dec})
01	Enable manual override	Enable for manual control of the holding brake	BOOL	RW	00
02	Manual brake state	Possible values: <ul style="list-style-type: none"> • 0_{dec}: Release • 1_{dec}: Apply 	BOOL	RW	00
05	Brake option	Configuration for inverted motor brakes Possible values: <ul style="list-style-type: none"> • 0_{dec}: Enable output to release brake • 1_{dec}: Disable output to release brake 	USINT	RW	0x0 (0 _{dec})
09	External override	Choice of a digital input that can be used to open the motor brake independently of the drive controller, e.g. for maintenance. Possible values: <ul style="list-style-type: none"> • 0_{dec}: Disabled • 2_{dec}: Digital Input 1 • 3_{dec}: Digital Input 1 (only INIT/PREOP/SAFEOP) • 4_{dec}: Digital Input 2 • 5_{dec}: Digital Input 2 (only INIT/PREOP/SAFEOP) 	USINT	RW	0x0 (0 _{dec})
11	Release delay	Time the holding brake requires for opening (releasing) after the current was applied. Unit: [ms]	UINT	RW	0x0 (0 _{dec})
12	Application delay	Time the holding brake requires for closing (holding) after the current was switched off. Unit: [ms]	UINT	RW	0x0 (0 _{dec})
13	Emergency application timeout	Time that the amplifier waits for the velocity to reach the standstill limit after a stop request. If the waiting time is exceeded, the holding brake is triggered; regardless of the velocity. Note: This parameter must be set at least to the longest time the axis needs to come to a standstill after it has been switched torque-free. For vertical axes, this parameter should be set to a low value to prevent the axis or load from falling very far. Unit: [ms]	UINT	RW	0x0 (0 _{dec})
14	Brake moment of inertia	Moment of inertia of the brake. Unit: [g cm ²]	UINT	RW	0x0 (0 _{dec})
18	Brake Output Features	Control of a motor brake (depending on the drive controller) via a digital output Possible values: <ul style="list-style-type: none"> • 0_{dec}: Disabled • 1_{dec}: Use Digital Output 1 as additional brake output • 2_{dec}: Use Digital Output 2 as additional brake output 	USINT	RW	0x0 (0 _{dec})

Index 2n05 Filter Settings Ch.x

- Index 2005: Filter Settings Ch.1
- Index 2805: Filter Settings Ch.2

Subindex (hex)	Name	Meaning	Data Type	Flags	Default
0	Filter Settings Ch.x		USINT	RO	0x19 (25 _{dec})
10	Low pass frequency 1	Unit: [Hz]	REAL	RW	0.0
11	Low pass damping 1		REAL	RW	0.0
12	High pass frequency 1	Unit: [Hz]	REAL	RW	0.0
13	High pass damping 1		REAL	RW	0.0
14	Filter type 1	Possible values: <ul style="list-style-type: none"> • 0_{dec}: No_Filter • 1_{dec}: Low_pass_filter_1_order • 2_{dec}: Phase_correction_filter_1_order • 3_{dec}: Low_pass_filter_2_order • 4_{dec}: Phase_correction_filter_2_order • 5_{dec}: Notch_filter 	INT	RW	0x0 (0 _{dec})
15	Low pass frequency 2	Unit: [Hz]	REAL	RW	0.0
16	Low pass damping 2		REAL	RW	0.0
17	High pass frequency 2	Unit: [Hz]	REAL	RW	0.0
18	High pass damping 2		REAL	RW	0.0
19	Filter type 2	Possible values: <ul style="list-style-type: none"> • 0_{dec}: No_Filter • 1_{dec}: Low_pass_filter_1_order • 2_{dec}: Phase_correction_filter_1_order • 3_{dec}: Low_pass_filter_2_order • 4_{dec}: Phase_correction_filter_2_order • 5_{dec}: Notch_filter 	INT	RW	0x0 (0 _{dec})

Index 2n0A Digital Output Settings Ch.x

- Index 200A: Digital Output Settings Ch.1
- Index 280A: Digital Output Settings Ch.2

Subindex (hex)	Name	Meaning	Data Type	Flags	Default
0	Digital Output Settings Ch.x		USINT	RO	0x2 (2 _{dec})
01	Use Output 1 as +24V power supply	If "TRUE": The respective digital output is always active and serves as supply voltage, e.g. for limit switches	BOOL	RW	00
02	Use Output 2 as +24V power supply		BOOL	RW	00

Index 2n10 Feedback Settings Ch.x

- Index 2010: Feedback Settings Ch.1
- Index 2810: Feedback Settings Ch.2

Subindex (hex)	Name	Meaning	Data Type	Flags	Default
0	Feedback Settings Ch. 1		USINT	RO	0x17 (23 _{dec})
11	Device type		UDINT	RW	0x0 (0 _{dec})
12	Singleturn bits	Number of single-turn bits used to represent the position in the process image. The sum of the single-turn bits and multi-turn bits must be 32.	USINT	RW	0x14 (20 _{dec})
13	Multiturn bits	Number of multi-turn bits used to represent the position in the process image. The sum of the single-turn bits and multi-turn bits must be 32.	USINT	RW	0xC (12 _{dec})
14	Observer bandwidth	Bandwidth of the velocity observer in [Hz]	UINT	RW	0xC8 (200 _{dec})
15	Observer feed-forward	Load ratio in [%] between internal rotor inertia of the motor and the total inertia of the driven system. Load ratio = internal moment of inertia / (internal moment of inertia + mass moment of inertia of the load). Examples: 100 % = load-free 50 % = moments of inertia of input and output are equal	USINT	RW	0x64 (100 _{dec})
17	Position offset	The position offset is subtracted from the raw position of the encoder. It can only be written with the axis stopped.	DINT	RW	0x0 (0 _{dec})

Index 2n20 Vendor data Ch.x

- Index 2020: Vendor data Ch.1
- Index 2820: Vendor data Ch.2

Subindex (hex)	Name	Meaning	Data type	Flags	Default
0	Vendor data Ch.x		USINT	RO	0x18 (24 _{dec})
11	Amplifier peak current	Amplifier peak current (peak value) Unit: [mA]	UDINT	RW	0x445C (17500 _{dec})
12	Amplifier rated current	Amplifier rated current (peak value) Unit: [mA]	UDINT	RW	0x1618 (5656 _{dec})
13	Amplifier thermal time constant	Thermal time constant Unit: [0.1 s]	UINT	RW	0x23 (35 _{dec})
14	Amplifier overcurrent threshold	Per-phase instantaneous current threshold for short-circuit detection Unit: [mA]	UDINT	RW	0x7530 (30000 _{dec})
15	Max rotary field frequency	Maximum rotary field frequency Unit: [Hz]	UINT	RW	0x257 (599 _{dec})
18	Vendor feature bits		UDINT	RW	0x0 (0 _{dec})
1A	Amplifier Rated Sum Current	Unit: [mA]	UDINT	RW	0x2C30 (11312 _{dec})

Index 2n08 DMC Settings Ch.x

- Index 2108: DMC Settings Ch.1
- Index 2908: DMC Settings Ch.2

Subindex (hex)	Name	Meaning	Data Type	Flags	Default
0	DMC Settings Ch.x	-	USINT	RO	0x17 (23 _{dec})
07	Emergency deceleration	Deceleration for the emergency stop ramp. (In [ms] from rated motor speed to standstill)	UINT	RW	0x64 (100 _{dec})
08	Calibration position	If homing is successful, the "Actual position" is set to this value.	LINT	RW	0x0 (0 _{dec})
09	Calibration velocity (towards plc cam)	Velocity when hitting the cam in 10000ths of the rated motor speed.	INT	RW	0x64 (100 _{dec})
0A	Calibration Velocity (off plc cam)	Velocity when driving off the cam in 10000ths of the rated motor speed.	INT	RW	0xA (10 _{dec})
0E	Modulo factor	Feedback increments for one mechanical revolution.	LINT	RW	0x100000000 (4294967296 _{dec})
12	Block calibration torque limit	Torque limitation for approaching the end stop. In parts per thousand of the rated motor current.	UINT	RW	0x64 (100 _{dec})
13	Block calibration stop distance	After reaching the calibration position, the axis moves out of the end position by this distance.	LINT	RW	0x100000000 (4294967296 _{dec})
14	Block calibration lag threshold	When this following error is exceeded, the axis is in the end position.	LINT	RW	0x100000000 (4294967296 _{dec})
15	Target position window	Target position window: The in-target bit is set when the axis is within this window for at least the time set under subindex 16.	LINT	RW	0x16C16C1 (23860929 _{dec})
16	Target position monitor time	See subindex 15 Unit: [ms]	UINT	RW	0x14 (20 _{dec})
17	Target position timeout	When the setpoint generator has reached its end position and the axis is not in the target window after this time has elapsed, the task is terminated and the in-target bit is not set. Unit: [ms]	UINT	RW	0x1770 (6000 _{dec})

Index 2n09 DMC Features Ch.x

- Index 2109: DMC Features Ch.1
- Index 2909: DMC Features Ch.2

Subindex (hex)	Name	Meaning	Data Type	Flags	Default
0	DMC Features Ch.x		USINT	RO	0x1B (27 _{dec})
13	Invert calibration cam search direction	Invert the direction of movement to search for the limit switch. Default: FALSE = search with positive direction of rotation.	BOOL	RW	00
14	Invert sync impulse search direction	Invert the direction of rotation to exit the limit switch. Default: TRUE = exit in negative direction of rotation.	BOOL	RW	01
19	Calibration cam source	Source for the reference switch: • 0 _{dec} : Input 1 • 1 _{dec} : Input 2	USINT	RW	0x0 (0 _{dec})
1A	Calibration cam active level	State of the reference switch in the actuated state: • 0 _{dec} : Hi • 1 _{dec} : Low	USINT	RW	0x0 (0 _{dec})
1B	Latch source	Source for the latch unit: • 0 _{dec} : Input 1 • 1 _{dec} : Input 2	USINT	RW	0x0 (0 _{dec})

F800 DRV Amplifier Settings

Index (hex)	Name	Meaning	Data Type	Flags	Default
F800:0	DRV Amplifier Settings		USINT	RO	0x17 (23 _{dec})
F800:10	Nominal DC link voltage	Rated DC link voltage. Unit: [mV]	UDINT	RW	0xBB80 (48000 _{dec})
F800:11	Min DC link voltage	Minimum DC link voltage. Unit: [mV]	UDINT	RW	0x1A90 (6800 _{dec})
F800:12	Max DC link voltage	Maximum DC link voltage. Unit: [mV]	UDINT	RW	0xEA60 (60000 _{dec})
F800:15	Amplifier Temperature warn level	Amplifier temperature warning threshold. Unit: [0.1 °C]	UINT	RW	0x320 (800 _{dec})
F800:16	Amplifier Temperature error level	Amplifier temperature error threshold. Unit: [0.1 °C]	UINT	RW	0x3E8 (1000 _{dec})
F800:17	Feature bits		UDINT	RW	0x0 (0 _{dec})

5.2 Information objects

2n30 Amplifier Diag data Ch.x

- Index 2030: Amplifier Diag data Ch.1
- Index 2830: Amplifier Diag data Ch.2

Subindex (hex)	Name	Meaning	Data Type	Flags	Default
0	Amplifier Diag data Ch.x		USINT	RO	0x11 (17 _{dec})
11	Amplifier I2T temperature	I ² T model utilization Unit: [%]	USINT	RO	-

2n31 Motor Diag data Ch.x

- Index 2031: Motor Diag data Ch.1
- Index 2831: Motor Diag data Ch.2

Subindex (hex)	Name	Meaning	Data Type	Flags	Default
0	Motor Diag data Ch.x		USINT	RO	0x11 (17 _{dec})
11	Motor I2T temperature	I ² T model utilization Unit: [%]	USINT	RO	-

2n40 Amplifier Info data Ch.x

- Index 2040: Amplifier Info data Ch.1
- Index 2840: Amplifier Info data Ch.2

Subindex (hex)	Name	Meaning	Data Type	Flags	Default
0	Amplifier Info data Ch.x		USINT	RO	0x29 (41 _{dec})
17	Cogging compensation supported	<ul style="list-style-type: none"> • If "TRUE": The drive controller supports cogging compensation and the required calibration data is available. • If "FALSE": Cogging compensation is not possible (not supported and/or no calibration data) 	BOOL	RO	0
18	Dynamic Containers Supported	If "TRUE": The drive controller supports dynamic containers (e.g. for Bode plot)	BOOL	RO	1
28	Actual motor brake state	Actual state of the motor brake (open, closed) <ul style="list-style-type: none"> • 0: Motor brake applied • 1: Motor brake released 	USINT	RO	-
29	Missing dynoutput cycle counter	Error counter for dynamic containers	UDINT	RO	-

2n42 Cycle Times Ch.x

- Index 2042: Cycle Times Ch.1
- Index 2842: Cycle Times Ch.2

Subindex (hex)	Name	Meaning	Data Type	Flags	Default
0	Cycle Times Ch.x		USINT	RO	0x8 (8 _{dec})
01	PWM Cycle Time	Unit: [ns]	UDINT	RO	0xF424 (62500 _{dec})
02	Current Control Min Oversampling Cycle Time	Unit: [ns]	UDINT	RO	0x7A12 (31250 _{dec})
03	Velocity Control Min Oversampling Cycle Time	Unit: [ns]	UDINT	RO	0xF424 (62500 _{dec})
04	Position Control Min Oversampling Cycle Time	Unit: [ns]	UDINT	RO	0xF424 (62500 _{dec})
05	Current Control Cycle Time	Unit: [ns]	UDINT	RO	0x7A12 (31250 _{dec})
06	Velocity Control Cycle Time	Unit: [ns]	UDINT	RO	0xF424 (62500 _{dec})
07	Position Control Cycle Time	Unit: [ns]	UDINT	RO	0xF424 (62500 _{dec})
08	DMC Cycle Time	Unit: [ns]	UDINT	RO	0xF424 (62500 _{dec})

2n5A Feedback Info Data Ch.x

- Index 205A: Feedback Info Data Ch.1
- Index 285A: Feedback Info Data Ch.2

Subindex (hex)	Name	Meaning	Data Type	Flags	Default
0	Feedback Info Data Ch.x		USINT	RO	0x1 (1 _{dec})
01	Raw Position		ULINT	RO	0x0 (0 _{dec})

F900 DRV Info data

Index (hex)	Name	Meaning	Data Type	Flags	Default
F900:0	DRV Info data		USINT	RO	0x12 (18 _{dec})
F900:11	Amplifier temperature	Internal temperature of the box. Unit: [0.1 °C]	INT	RO	-
F900:12	DC link voltage	Measured value of the DC link voltage. Unit: [mV]	UDINT	RO	-

F913 DRV Device Info data

Index (hex)	Name	Meaning	Data Type	Flags	Default
F913:0	DRV Device Info data		USINT	RO	0x6 (6 _{dec})
F913:01	HW config	-	STRING(32)	RO	-
F913:03	FW info	-	STRING(32)	RO	-
F913:04	DMC version	-	STRING(32)	RO	-
F913:06	Device Type	-	UDINT	RO	-

5.3 Input data, output data

Index 2n08 Inputs Ch.x

- Index 2008: Inputs Ch.1
- Index 2808: Inputs Ch.2

Subindex (hex)	Name	Meaning	Data type	Flags	Default
0	Inputs Ch.x		USINT	RO	0x6 (6 _{dec})
01	Info data 1	Synchronous information Selection via subindex 2n02:55	UINT	RO	-
02	Info data 2	Synchronous information Selection via subindex 2n02:56	UINT	RO	-
03	Info data 3	Synchronous information Selection via subindex 2n02:58	UINT	RO	-
04	Dyninput cycle counter	-	USINT	RO	-
06	Velocity resulting from differentiation	-	DINT	RO	-

Index 2n0B Remote Outputs Ch.x

- Index 200B: Remote Outputs Ch.1
- Index 280B: Remote Outputs Ch.2

Subindex (hex)	Name	Meaning	Data type	Flags	Default
0	Remote Outputs Ch.x		USINT	RO	0xF (15 _{dec})
04	Dynoutput cycle counter	-	USINT	RO	-
06	Target velocity	Configured target velocity $2^{32}/16000$ increments correspond to one motor revolution per second	DINT	RO	-
09	Target torque	Configured target torque The value is specified in thousandths (1/1000) of parameter 6075 "Motor rated current". Calculation formula: $M = ((\text{Torque actual value} / 1000) \times \text{rated current}) \times \text{torque constant (0x2003:16)}$	INT	RO	-
0A	Torque offset	External torque feedforward The value is specified in thousandths (1/1000) of parameter 6075 "Motor rated current". Calculation formula: $M = ((\text{Torque actual value} / 1000) \times \text{rated current}) \times \text{torque constant (0x2003:16)}$	INT	RO	-
0E	Commutation angle	Commutation angle for CSTCA mode. Unit: $2^{16} / 360^\circ$	UINT	RO	-
0F	Velocity offset	External velocity feedforward	DINT	RO	-

Index 2n00 DMC Inputs Ch.x

- Index 2100: DMC Inputs Ch.1
- Index 2900: DMC Inputs Ch.2

Subindex (hex)	Name	Meaning	Data Type	Flags	Default
0	DMC Inputs Ch.x		USINT	RO	0x3C (60 _{dec})
02	DMC__FeedbackStatus__Latched extern valid	An edge was detected on the external input and latched.	BOOL	RO	-
03	DMC__FeedbackStatus__Set counter done	The setting of the feedback position was successful. This bit remains present until "Set counter" is released again	BOOL	RO	-
0D	DMC__FeedbackStatus__Status of extern latch	Status of the external latch input.	BOOL	RO	-
11	DMC__DriveStatus__Ready to enable	The drive hardware is ready for activation.	BOOL	RO	-
12	DMC__DriveStatus__Ready	The drive hardware is activated.	BOOL	RO	-
13	DMC__DriveStatus__Warning	A warning is pending in the drive.	BOOL	RO	-
14	DMC__DriveStatus__Error	An error is pending in the drive. The "Ready to enable" bit and the "Ready" bit are set to FALSE.	BOOL	RO	-
15	DMC__DriveStatus__Moving positive	The axis moves in positive direction.	BOOL	RO	-
16	DMC__DriveStatus__Moving negative	The axis moves in negative direction.	BOOL	RO	-
1C	DMC__DriveStatus__Digital input 1	Status of the first digital input.	BOOL	RO	-
1D	DMC__DriveStatus__Digital input 2	Status of the second digital input.	BOOL	RO	-
21	DMC__PositioningStatus__Busy	The positioning task is running.	BOOL	RO	-
22	DMC__PositioningStatus__In-Target	The axis is at the target position.	BOOL	RO	-

Subindex (hex)	Name	Meaning	Data Type	Flags	Default
23	DMC__PositioningStatus__Warning	Warning.	BOOL	RO	-
24	DMC__PositioningStatus__Error	Error.	BOOL	RO	-
25	DMC__PositioningStatus__Calibrated	The axis is calibrated.	BOOL	RO	-
26	DMC__PositioningStatus__Accelerate	The axis accelerates.	BOOL	RO	-
27	DMC__PositioningStatus__Decelerate	The axis is decelerating.	BOOL	RO	-
28	DMC__PositioningStatus__Ready to execute	The drive motion control is ready to accept a command. This bit is FALSE ... <ul style="list-style-type: none"> • ... if the drive has a fault • ... if the drive is not activated ... as long as the "PositioningControl__Execute" is pending.	BOOL	RO	-
31	DMC__Set position	Current target position specified by the ramp generator in feedback increments.	LINT	RO	-
32	DMC__Set velocity	Current velocity specified by the ramp generator in 10000ths of the rated motor speed	INT	RO	-
33	DMC__Actual drive time	The time since the start of the travel command in ms. Stops when the target position is reached.	UDINT	RO	-
34	DMC__Actual position lag	Following error.	LINT	RO	-
35	DMC__Actual velocity	Current velocity in 10000ths of the rated motor speed.	INT	RO	-
36	DMC__Actual position	Current position from the feedback (incl. possible offsets due to homing, ...).	LINT	RO	-
37	DMC__Error id	Error Id (Identical to Diag History).	UDINT	RO	-
38	DMC__Input cycle counter	Incremented with each process data cycle.	USINT	RO	-
39	DMC__Channel id		USINT	RO	-
3A	DMC__Latch value	Feedback position at latch time.	LINT	RO	-
3B	DMC__Cyclic info data 1	Synchronous info data	INT	RO	-
3C	DMC__Cyclic info data 2	Synchronous info data	INT	RO	-

Index 2n04 DMC Outputs Ch.x

- Index 2104: DMC Outputs Ch.1
- Index 2904: DMC Outputs Ch.2

Subindex (hex)	Name	Meaning	Data Type	Flags	Default
0	DMC Outputs Ch.x		USINT	RO	0x36 (54 _{dec})
02	DMC__FeedbackControl__Enable latch extern on positive edge	Latches to the positive edge of the external input	BOOL	RO	-
03	DMC__FeedbackControl__Set counter	With a rising edge, "Actual position" is set to the value of "Set counter value".	BOOL	RO	-
04	DMC__FeedbackControl__Enable latch extern on negative edge	Latches to the negative edge of the external input	BOOL	RO	-
11	DMC__DriveControl__Enable	Activate drive	BOOL	RO	-
12	DMC__DriveControl__Reset	Perform a reset of the drive hardware	BOOL	RO	-
21	DMC__PositioningControl__Execute	Start motion command with rising edge The task runs as long as this bit is set or until the command is completed. If the level drops during travel, the axis is brought to a standstill with the deceleration specified for the task.	BOOL	RO	-
22	DMC__PositioningControl__Emergency stop	In the event of a rising edge, decelerate to a standstill with the emergency stop ramp	BOOL	RO	-
31	DMC__Set counter value	s. 0x2n04:03	LINT	RO	-
32	DMC__Target position	Position specification in feedback increments	LINT	RO	-
33	DMC__Target velocity	Maximum velocity during the motion command in 10000ths of the rated motor speed	INT	RO	-
34	DMC__Start type	Type of positioning task: 0x0001: Absolute 0x0002: Relative 0x0003: Endless + 0x0004: Endless - 0x0105: Modulo short 0x0205: Modulo + 0x0305: Modulo - 0x6000: Cali PLC cam 0x6200: Cali Block 0x6E00: Cali set 0x6F00: Cali clear	UINT	RO	-
35	DMC__Target acceleration	Acceleration: time in ms from standstill to reaching the rated motor speed	UINT	RO	-
36	DMC__Target deceleration	Deceleration: time in ms for the deceleration from the rated motor speed to standstill	UINT	RO	-

Index 6n3E TxPDO Data Invalid Ch.x

- Index 603E: TxPDO Data Invalid Ch.1
- Index 683E: TxPDO Data Invalid Ch.2

Subindex (hex)	Name	Meaning	Data type	Flags	Default
0	TxPDO Data Invalid Ch.1		USINT	RO	0x2 (2 _{dec})
02	Position actual value	-	BOOL	RO	-

Index 6n3F Error code Ch.x

- Index 603F: Error code Ch.1
- Index 683F: Error code Ch.2

Subindex (hex)	Name	Meaning	Data type	Flags	Default
0	Error code Ch.x	-	UINT	RO	-

Index 6n40 Controlword Ch.x

- Index 6040: Controlword Ch.1
- Index 6840: Controlword Ch.2

Subindex (hex)	Name	Meaning	Data type	Flags	Default
0	Controlword Ch.x	Bit 0: Switch on Bit 1: Enable voltage Bit 2: reserved Bit 3: Enable operation Bit 4 - 6: reserved Bit 7: Fault reset Bit 8 - 15: reserved	UINT	RO	-

Index 6n41 Statusword Ch.x

- Index 6041: Statusword Ch.1
- Index 6841: Statusword Ch.2

Subindex (hex)	Name	Meaning	Data type	Flags	Default
0	Statusword Ch.x	Bit 0: Ready to switch on Bit 1: Switched on Bit 2: Operation enabled Bit 3: Fault Bit 4: reserved Bit 5: reserved Bit 6: Switch on disabled Bit 7: Warning Bit 8 + 9: reserved Bit 10: TxPDOToggle Bit 11: Internal limit active Bit 12: Drive follows the command value Bit 13: Input cycle counter Bit 14 - 15: reserved	UINT	RO	-

Index 6n5E Fault reaction option code Ch.x

- Index 605E: Fault reaction option code Ch.1
- Index 685E: Fault reaction option code Ch.2

Subindex (hex)	Name	Meaning	Data type	Flags	Default
0	Fault reaction option code Ch.x	Possible values: <ul style="list-style-type: none"> • 0: Disable drive function, motor is free to rotate • 1: Slow down on slow down ramp 	UINT	RO	0x0001 (1 _{dec})

Index 6n60 Modes of operation Ch.x

- Index 6060: Modes of operation Ch.1
- Index 6860: Modes of operation Ch.2

Subindex (hex)	Name	Meaning	Data type	Flags	Default
0	Modes of operation Ch.x	Possible values: <ul style="list-style-type: none"> • -125_{dec}: Drive Motion Control (DMC) • -9_{dec}: Cyclic synchronous velocity mode remote (CSVr) • 8_{dec}: Cyclic synchronous position mode (CSP) • 9_{dec}: Cyclic synchronous velocity mode (CSV) • 11_{dec}: Cyclic synchronous torque mode with commutation angle (CSTCA) 	SINT	RO	0x08 (8_{dec})

Index 6n61 Modes of operation display Ch.x

- Index 6061: Modes of operation display Ch.1
- Index 6861: Modes of operation display Ch.2

Subindex (hex)	Name	Meaning	Data type	Flags	Default
0	Modes of operation display Ch.x	Possible values: <ul style="list-style-type: none"> • -125_{dec}: Drive Motion Control (DMC) • -9_{dec}: Cyclic synchronous velocity mode remote (CSVr) • 8_{dec}: Cyclic synchronous position mode (CSP) • 9_{dec}: Cyclic synchronous velocity mode (CSV) • 11_{dec}: Cyclic synchronous torque mode with commutation angle (CSTCA) 	USINT	RO	-

Index 6n64 Position actual value Ch.x

- Index 6064: Position actual value Ch.1
- Index 6864: Position actual value Ch.2

Subindex (hex)	Name	Meaning	Data type	Flags	Default
0	Position actual value Ch.x	Actual position 2^{20} increments correspond to one motor revolution	DINT	RO	-

Index 6n65 Following error window Ch.x

- Index 6065: Following error window Ch.1
- Index 6865: Following error window Ch.2

Subindex (hex)	Name	Meaning	Data type	Flags	Default
0	Following error window Ch.x	Following error window The specified value must be multiplied by the corresponding scaling factor <ul style="list-style-type: none"> • $0xFFFFFFFF (-1_{dec})$ = Following error monitoring off. • Any other value = following error monitoring on 	UDINT	RO	$0xFFFFFFFF (-1_{dec})$

Index 6n66 Following error time out Ch.x

- Index 6066: Following error time out Ch.1
- Index 6866: Following error time out Ch.2

Subindex (hex)	Name	Meaning	Data type	Flags	Default
0	Following error time out Ch.x	Following error monitoring timeout Unit: [ms] If the following error exceeds the following-error window for longer than the timeout set here, the system triggers an error response.	UINT	RO	-

Index 6n6C Velocity actual value Ch.x

- Index 606C: Velocity actual value Ch.1
- Index 686C: Velocity actual value Ch.2

Subindex (hex)	Name	Meaning	Data type	Flags	Default
0	Velocity actual value Ch.x	Actual velocity $2^{32}/16000$ increments correspond to one motor revolution per second	DINT	RO	-

Index 6n7B Position range limit Ch.x

- Index 607B: Position range limit Ch.1
- Index 687B: Position range limit Ch.2

Subindex (hex)	Name	Meaning	Data type	Flags	Default
0	Position range limit Ch.x		USINT	RO	0x2 (2 _{dec})
01	Min position range limit	Minimum value for the position display of setpoints and actual values. If the value falls below this limit, it underflows to "Max position range limit" "Min position range limit" must always be lower than "Max position range limit"	DINT	RW	0x80000000 (-2147483648 _{dec})
02	Max position range limit	Maximum value for the position display of setpoints and actual values. If this limit is exceeded, the value overflows to "Min position range limit" "Max position range limit" must always be greater than "Min position range limit"	DINT	RW	0x7FFFFFFF (2147483647 _{dec})

Index 6n71 Target torque Ch.x

- Index 6071: Target torque Ch.1
- Index 6871: Target torque Ch.2

Subindex (hex)	Name	Meaning	Data type	Flags	Default
0	Target torque Ch.x	Configured target torque The value is specified in thousandths (1/1000) of parameter 6075 "Motor rated current" Calculation formula: $M = ((\text{Torque actual value} / 1000) \times \text{rated current}) \times \text{torque constant} (0x2003:16)$	INT	RO	-

Index 6n72 Max torque Ch.x

- Index 6072: Max torque Ch.1
- Index 6872: Max torque Ch.2

Subindex (hex)	Name	Meaning	Data type	Flags	Default
0	Max torque Ch.x	Maximum torque	UINT	RO	-

Index 6n75 Motor rated current Ch.x

- Index 6075: Motor rated current Ch.1
- Index 6875: Motor rated current Ch.2

Subindex (hex)	Name	Meaning	Data type	Flags	Default
0	Motor rated current Ch.x	Nominal current of the motor Unit: [mA]	UDINT	RO	-

Index 6n77 Torque actual value Ch.x

- Index 6077: Torque actual value Ch.1
- Index 6877: Torque actual value Ch.2

Subindex (hex)	Name	Meaning	Data type	Flags	Default
0	Torque actual value Ch.x	Actual torque The value is specified in thousandths (1/1000) of parameter 6075 "Motor rated current" Calculation formula: $M = ((\text{Torque actual value} / 1000) \times \text{rated current}) \times \text{torque constant (0x2003:16)}$	INT	RO	-

Index 6n79 DC link circuit voltage Ch.x

- Index 6079: DC link circuit voltage Ch.1
- Index 6879: DC link circuit voltage Ch.2

Subindex (hex)	Name	Meaning	Data type	Flags	Default
0	DC link circuit voltage Ch.x	Measured value of the DC link voltage Unit: [mV]	UDINT	RO	-

Index 6n7A Target position Ch.x

- Index 607A Target position Ch.1
- Index 687A Target position Ch.2

Subindex (hex)	Name	Meaning	Data type	Flags	Default
0	Target position Ch.x	Configured actual position 2^{20} increments correspond to one motor revolution	DINT	RO	-

Index 6n7E Polarity Ch.x

- Index 607E: Polarity Ch.1
- Index 687E: Polarity Ch.2

Subindex (hex)	Name	Meaning	Data type	Flags	Default
0	Polarity Ch.x	Possible values: <ul style="list-style-type: none"> • 0: global polarity inversion disabled • 1: global polarity inversion 	USINT	RO	0

Index 6n80 Max motor speed Ch.x

- Index 6080: Max motor speed Ch.1
- Index 6880: Max motor speed Ch.2

Subindex (hex)	Name	Meaning	Data type	Flags	Default
0	Max motor speed Ch.x	Maximum velocity of the motor Unit: [1/min]	UDINT	RO	0x000186A0 (100000 _{dec})

Index 6n91 Gear ratio Ch.x

- Index 6091: Gear ratio Ch.1
- Index 6891: Gear ratio Ch.2

Subindex (hex)	Name	Meaning	Data Type	Flags	Default
0	Gear ratio Ch.x		USINT	RO	0x2 (2 _{dec.})
01	Motor shaft revolutions	These parameters are used to scale all positions and velocities from the motor side to the load side of a gear unit.	UDINT	RW	0x1 (1 _{dec.})
02	Driving shaft revolutions	<p>"Motor shaft revolutions" describes the number of motor revolutions required to achieve the number of load revolutions configured in "Driving shaft revolutions".</p> <p>Example: For a reduction gear in which 5 motor revolutions result in 2 load revolutions, set the parameters as follows:</p> <ul style="list-style-type: none"> • Motor shaft revolutions = 5 • Driving shaft revolutions = 2 	UDINT	RW	0x1 (1 _{dec.})

Index 6nB1 Velocity offset Ch.x

- Index 60B1: Velocity offset Ch.1
- Index 68B1: Velocity offset Ch.2

Subindex (hex)	Name	Meaning	Data type	Flags	Default
0	Velocity offset Ch.x	External velocity feedforward	DINT	RO	-

Index 6nB2 Torque offset Ch.x

- Index 60B2: Torque offset Ch.1
- Index 68B2: Torque offset Ch.2

Index (hex)	Name	Meaning	Data type	Flags	Default
0	Torque offset Ch.x	<p>External torque feedforward</p> <p>The value is specified in thousandths (1/1000) of parameter 6075 "Motor rated current"</p> <p>Calculation formula: $M = ((\text{Torque actual value} / 1000) \times \text{rated current}) \times \text{torque constant (0x2003:16)}$</p>	INT	RO	-

Index 6nB8 Touch probe function Ch.x

- Index 60B8 Touch probe function Ch.1
- Index 68B8 Touch probe function Ch.2

Index (hex)	Name	Meaning	Data type	Flags	Default
0	Touch probe function Ch.x	<ul style="list-style-type: none"> • Bit 0: TP1 enable • Bit 1: TP1 Continuous • Bit 2: TP1 Trigger mode • Bit 3: - • Bit 4: TP1 Enable pos. Edge • Bit 5: TP1 Enable neg. edge • Bit 6: - • Bit 7: - • Bit 8: TP2 Enable • Bit 9: TP2 Continuous • Bit 10: TP2 Trigger mode • Bit 11: - • Bit 12: TP2 Enable pos. Edge • Bit 13: TP2 Enable neg. edge • Bit 14: - • Bit 15: - 	UINT	RO	-

Index 6nB9 Touch probe status Ch.x

- Index 60B9 Touch probe status Ch.1
- Index 68B9 Touch probe status Ch.2

Subindex (hex)	Name	Meaning	Data type	Flags	Default
0	Touch probe status Ch.x	<ul style="list-style-type: none"> • Bit 0: TP1 Enable • Bit 1: TP1 Pos. value stored • Bit 2: TP1 Input • Bit 7: TP1 Input • Bit 8: TP2 Enable • Bit 9: TP2 Pos. value stored • Bit 10: TP2 Neg. value stored • Bit 15: TP2 Input 	UINT	RO	-

Index 6nBA Touch probe 1 positive edge Ch.x

- Index 60BA Touch probe 1 positive edge Ch.1
- Index 68BA Touch probe 1 positive edge Ch.2

Subindex (hex)	Name	Meaning	Data type	Flags	Default
0	Touch probe 1 positive edge Ch.x	Position value at the last detected rising edge of TP1. 2 ²⁰ increments correspond to one motor revolution	DINT	RO	-

Index 6nBB Touch probe 1 negative edge Ch.x

- Index 60BB Touch probe 1 negative edge Ch.1
- Index 68BB Touch probe 1 negative edge Ch.2

Subindex (hex)	Name	Meaning	Data type	Flags	Default
0	Touch probe 1 negative edge Ch.x	Position value at the last detected rising edge of TP1. 2 ²⁰ increments correspond to one motor revolution	DINT	RO	-

Index 6nBC Touch probe 2 positive edge Ch.x

- Index 60BC Touch probe 2 positive edge Ch.1
- Index 68BC Touch probe 2 positive edge Ch.2

Subindex (hex)	Name	Meaning	Data type	Flags	Default
0	Touch probe 2 positive edge Ch.x	Position value at the last detected rising edge of TP2. 2 ²⁰ increments correspond to one motor revolution	DINT	RO	-

Index 6nBD Touch probe 2 negative edge Ch.x

- Index 60BD: Touch probe 2 negative edge Ch.1
- Index 68BD: Touch probe 2 negative edge Ch.2

Subindex (hex)	Name	Meaning	Data type	Flags	Default
0	Touch probe 2 negative edge Ch.x	Position value at the last detected falling edge of TP2. 2 ²⁰ increments correspond to one motor revolution	DINT	RO	-

6nD0 Touch probe source Ch.x

- 60D0 Touch probe source Ch.1
- 68D0 Touch probe source Ch.2

Subindex (hex)	Name	Meaning	Data Type	Flags	Default
0	Touch probe source Ch.x		USINT	RO	0x2 (2 _{dec})
01	Touch probe 1 source	Possible values: • 1 _{dec} : Touch probe input 1	INT	RW	0x1 (1 _{dec})
02	Touch probe 2 source	Possible values: • 2 _{dec} : Touch probe input 2	INT	RW	0x2 (2 _{dec})

Index 6nD1 Touch probe time stamp 1 positive value Ch.x

- Index 60D1: Touch probe time stamp 1 positive value Ch.1
- Index 68D1: Touch probe time stamp 1 positive value Ch.2

Subindex (hex)	Name	Meaning	Data type	Flags	Default
0	Touch probe time stamp 1 positive value Ch.x	Position value at the last detected rising edge of TP1	UDINT	RO	-

Index 6nD2 Touch probe time stamp 1 negative value Ch.x

- Index 60D2: Touch probe time stamp 1 negative value Ch.1
- Index 68D2: Touch probe time stamp 1 negative value Ch.2

Subindex (hex)	Name	Meaning	Data type	Flags	Default
0	Touch probe time stamp 1 negative value Ch.x	Position value at the last detected falling edge of TP1	UDINT	RO	-

Index 6nD3 Touch probe time stamp 2 positive value Ch.x

- Index 60D3: Touch probe time stamp 2 positive value Ch.1
- Index 68D3: Touch probe time stamp 2 positive value Ch.2

Subindex (hex)	Name	Meaning	Data type	Flags	Default
0	Touch probe time stamp 2 positive value Ch.x	Position value at the last detected rising edge of TP2	UDINT	RO	-

Index 6nD4 Touch probe time stamp 2 negative value Ch.x

- Index 60D4: Touch probe time stamp 2 negative value Ch.1

- Index 68D4: Touch probe time stamp 2 negative value Ch.2

Subindex (hex)	Name	Meaning	Data type	Flags	Default
0	Touch probe time stamp 2 negative value Ch.x	Position value at the last detected falling edge of TP2	UDINT	RO	-

Index 6nD9 Supported synchronization functions Ch.x

- Index 60D9: Supported synchronization functions Ch.1
- Index 68D9: Supported synchronization functions Ch.2

Subindex (hex)	Name	Meaning	Data type	Flags	Default
0	Supported synchronization functions Ch.x		UDINT	RO	0x0000003 (3 _{dec})

Index 6nDA Synchronization function settings Ch.x

- Index 60DA: Synchronization function settings Ch.1
- Index 68DA: Synchronization function settings Ch.2

Subindex (hex)	Name	Meaning	Data type	Flags	Default
0	Synchronization function settings Ch.x	-	UDINT	RO	-

Index 6nE0 Positive torque limit value Ch.x

- Index 60E0: Positive torque limit value Ch.1
- Index 68E0: Positive torque limit value Ch.2

Subindex (hex)	Name	Meaning	Data type	Flags	Default
0	Positive torque limit value Ch.x	Torque limit in the positive direction of rotation	UINT	RO	0x7FFF (32767 _{dec})

Index 6nE1 Negative torque limit value Ch.x

- Index 60E1: Negative torque limit value Ch.1
- Index 68E1: Negative torque limit value Ch.2

Subindex (hex)	Name	Meaning	Data type	Flags	Default
0	Negative torque limit value Ch.1	Torque limit in the negative direction of rotation	UINT	RO	0x7FFF (32767 _{dec})

Index 6nEA Commutation angle Ch.x

- Index 60EA: Commutation angle Ch.1
- Index 68EA: Commutation angle Ch.2

Subindex (hex)	Name	Meaning	Data type	Flags	Default
0	Commutation angle Ch.x	Commutation angle for the CSTCA operating mode Unit: 2 ¹⁶ / 360°	UINT	RO	-

Index 6nF4 Following error actual value Ch.x

- Index 60F4: Following error actual value Ch.1
- Index 68F4: Following error actual value Ch.2

Subindex (hex)	Name	Meaning	Data type	Flags	Default
0	Following error actual value Ch.x	Current following error	DINT	RO	-

Index 6nFD Digital Inputs Ch.x

- Index 60FD: Digital Inputs Ch.1
- Index 68FD: Digital Inputs Ch.2

Subindex (hex)	Name	Meaning	Data type	Flags	Default
0	Digital Inputs Ch.x	-	UDINT	RO	-

Index 6nFE Digital Outputs Ch.x

- Index 60FE: Digital Outputs Ch.1
- Index 68FE: Digital Outputs Ch.2

Subindex (hex)	Name	Meaning	Data type	Flags	Default
0	Digital Outputs Ch.x		USINT	RO	0x1 (1 _{dec})
01	Digital Outputs	Controls the digital outputs of the digital combination channels: <ul style="list-style-type: none"> • DIO1: Bit 16 (0x00010000) • DIO2: Bit 17 (0x00020000) 	UDINT	RW	0x0 (0 _{dec})

Index 6nFF Target velocity Ch.x

- Index 60FF: Target velocity Ch.1
- Index 68FF: Target velocity Ch.2

Subindex (hex)	Name	Meaning	Data type	Flags	Default
0	Target velocity Ch.x	Configured actual velocity 2 ³² /16000 increments correspond to one motor revolution per second	DINT	RO	-

Index 6n02 Supported drive modes Ch.x

- Index 6502: Supported drive modes Ch.1
- Index 6D02: Supported drive modes Ch.2

Subindex (hex)	Name	Meaning	Data type	Flags	Default
0	Supported drive modes Ch.x	Specification of the supported operating modes: <ul style="list-style-type: none"> • Bit 0: PP • Bit 1: VL • Bit 2: PV • Bit 3: TQ • Bit 4: R • Bit 5: HM • Bit 6: IP • Bit 7: CSP • Bit 8: CSV • Bit 9: CST • Bit 10: CSTCA • Bit 11...15: reserved • Bit 16...31: Manufacturer-specific 	UDINT	RO	0x00000580 (1408 _{dec})

5.4 Standard objects

1000 Device type

Index (hex)	Name	Meaning	Data type	Flags	Default
1000:0	Device type	EtherCAT slave device type: the low word contains the CoE profile used (402 _{dec}).	UDINT	RO	0x00020192 (131474 _{dec})

1001 Error register

Index (hex)	Name	Meaning	Data Type	Flags	Default
1001:0	Error register	-	USINT	RO	-

1008 Device name

Index (hex)	Name	Meaning	Data Type	Flags	Default
1008:0	Device name	Device name of the EtherCAT slave	STRING(19)	RO	-

1009 Hardware version

Index (hex)	Name	Meaning	Data Type	Flags	Default
1009:0	Hardware version	Hardware version of the EtherCAT slave	STRING(2)	RO	-

100A Software version

Index (hex)	Name	Meaning	Data Type	Flags	Default
100A:0	Software version	Firmware version of the EtherCAT slave	STRING(2)	RO	-

100B Bootloader version

Index (hex)	Name	Meaning	Data Type	Flags	Default
100B:0	Bootloader version	-	STRING(32)	RO	-

1011 Restore default parameters

Index (hex)	Name	Meaning	Data Type	Flags	Default
1011:0	Restore default parameters	Restoring the default parameters	USINT	RO	0x1 (1 _{dec})

1018 Identity

Index (hex)	Name	Meaning	Data Type	Flags	Default
1018:0	Identity	Information for identifying the slave	USINT	RO	0x4 (4 _{dec})
1018:01	Vendor ID	Vendor ID of the EtherCAT slave	UDINT	RO	0x2 (2 _{dec})
1018:02	Product code	Product code of the EtherCAT slave	UDINT	RO	0x1CF44052 (485769298 _{dec})
1018:03	Revision	Revision number of the EtherCAT slave; the Low Word (bit 0-15) indicates the special terminal number, the High Word (bit 16-31) refers to the device description	UDINT	RO	-
1018:04	Serial number	Serial number of the EtherCAT slave; the low byte (bit 0-7) of the low word contains the year of production, the high byte (bit 8-15) of the low word contains the week of production, the high word (bit 16-31) is 0	UDINT	RO	-

1020 Device Statistics

Index (hex)	Name	Meaning	Data Type	Flags	Default
1020:0	Device Statistics		USINT	RO	0x3 (3 _{dec})
1020:01	Time since power on	Operating time since last power-on [s]	UDINT	RO	-
1020:02	Total time powered	Total operating time [s]	UDINT	RO	-
1020:03	Number of power cycles	Number of power cycles	UDINT	RO	-

10E2 Manufacturer-specific Identification Code

Index (hex)	Name	Meaning	Data Type	Flags	Default
10E2:0	Manufacturer-specific Identification Code	eBIC	USINT	RO	0x1 (1 _{dec})

10F0 Backup parameter handling

Index (hex)	Name	Meaning	Data Type	Flags	Default
10F0:0	Backup parameter handling		USINT	RO	0x1 (1 _{dec})
10F0:01	Checksum	Checksum across all backup entries of the EtherCAT slave	UDINT	RO	-

10F3 Diagnosis History

Index (hex)	Name	Meaning	Data Type	Flags	Default
10F3:0	Diagnosis History		USINT	RO	0x37 (55 _{dec})
10F3:01	Maximum Messages	Maximum number of stored messages	USINT	RO	-
10F3:02	Newest Message	Subindex of the newest message	USINT	RO	-
10F3:03	Newest Acknowledged Message	Subindex of the last acknowledged message	USINT	RW	-
10F3:04	New Messages Available	Indicates that a new message is available	BOOL	RO	-
10F3:05	Flags	-	UINT	RW	-
10F3:06	Diagnosis Message 001	-	ARRAY [0..31] OF BYTE	RO	-
10F3:07	Diagnosis Message 002	-	ARRAY [0..31] OF BYTE	RO	-
10F3:08	Diagnosis Message 003	-	ARRAY [0..31] OF BYTE	RO	-
...
10F3:35	Diagnosis Message 048	-	ARRAY [0..31] OF BYTE	RO	-
10F3:36	Diagnosis Message 049	-	ARRAY [0..31] OF BYTE	RO	-
10F3:37	Diagnosis Message 050	-	ARRAY [0..31] OF BYTE	RO	-

10F8 Timestamp Object

Index (hex)	Name	Meaning	Data Type	Flags	Default
10F8:0	Timestamp Object	-	ULINT	RO	-

1460 DS402 RxPDO-Par Outputs Ch.1

Index (hex)	Name	Meaning	Data Type	Flags	Default
1460:0	DS402 RxPDO-Par Outputs Ch.1		USINT	RO	0x6 (6 _{dec})
1460:06	Exclude RxPDOs		ARRAY [0..1] OF BYTE	RO	[6116]

1461 DS402 RxPDO-Par Outputs 32 Bit Ch.1

Index (hex)	Name	Meaning	Data Type	Flags	Default
1461:0	DS402 RxPDO-Par Outputs 32 Bit Ch.1		USINT	RO	0x6 (6 _{dec})
1461:06	Exclude RxPDOs		ARRAY [0..1] OF BYTE	RO	[6016]

14E0 DS402 RxPDO-Par Outputs Ch.2

Index (hex)	Name	Meaning	Data Type	Flags	Default
14E0:0	DS402 RxPDO-Par Outputs Ch.2		USINT	RO	0x6 (6 _{dec})
14E0:06	Exclude RxPDOs		ARRAY [0..1] OF BYTE	RO	[e116]

14E1 DS402 RxPDO-Par Outputs 32 Bit Ch.2

Index (hex)	Name	Meaning	Data Type	Flags	Default
14E1:0	DS402 RxPDO-Par Outputs 32 Bit Ch.2		USINT	RO	0x6 (6 _{dec})
14E1:06	Exclude RxPDOs		ARRAY [0..1] OF BYTE	RO	[e016]

1600 DS402 RxPDO-Map Controlword Ch.1

Index (hex)	Name	Meaning	Data Type	Flags	Default
1600:0	DS402 RxPDO-Map Controlword Ch.1		USINT	RO	0x1 (1 _{dec})
1600:01	SubIndex 001		UDINT	RO	0x6040:00, 16

1601 DS402 RxPDO-Map Target velocity Ch.1

Index (hex)	Name	Meaning	Data Type	Flags	Default
1601:0	DS402 RxPDO-Map Target velocity Ch.1		USINT	RO	0x1 (1 _{dec})
1601:01	SubIndex 001		UDINT	RO	0x60ff:00, 32

1602 DS402 RxPDO-Map Target torque Ch.1

Index (hex)	Name	Meaning	Data Type	Flags	Default
1602:0	DS402 RxPDO-Map Target torque Ch.1		USINT	RO	0x1 (1 _{dec})
1602:01	SubIndex 001		UDINT	RO	0x6071:00, 16

1603 DS402 RxPDO-Map Commutation angle Ch.1

Index (hex)	Name	Meaning	Data Type	Flags	Default
1603:0	DS402 RxPDO-Map Commutation angle Ch.1		USINT	RO	0x1 (1 _{dec})
1603:01	SubIndex 001		UDINT	RO	0x60ea:00, 16

1604 DS402 RxPDO-Map Torque limitation Ch.1

Index (hex)	Name	Meaning	Data Type	Flags	Default
1604:0	DS402 RxPDO-Map Torque limitation Ch.1		USINT	RO	0x1 (1 _{dec})
1604:01	SubIndex 001		UDINT	RO	0x6072:00, 16

1605 DS402 RxPDO-Map Torque offset Ch.1

Index (hex)	Name	Meaning	Data Type	Flags	Default
1605:0	DS402 RxPDO-Map Torque offset Ch.1		USINT	RO	0x1 (1 _{dec})
1605:01	SubIndex 001		UDINT	RO	0x60b2:00, 16

1606 DS402 RxPDO-Map Target position Ch.1

Index (hex)	Name	Meaning	Data Type	Flags	Default
1606:0	DS402 RxPDO-Map Target position Ch.1		USINT	RO	0x1 (1 _{dec})
1606:01	SubIndex 001		UDINT	RO	0x607a:00, 32

1607 DS402 RxPDO-Map Touch probe function Ch.1

Index (hex)	Name	Meaning	Data Type	Flags	Default
1607:0	DS402 RxPDO-Map Touch probe function Ch.1		USINT	RO	0x1 (1 _{dec})
1607:01	SubIndex 001		UDINT	RO	0x60b8:00, 16

1608 DS402 RxPDO-Map Modes of operation Ch.1

Index (hex)	Name	Meaning	Data Type	Flags	Default
1608:0	DS402 RxPDO-Map Modes of operation Ch.1		USINT	RO	0x1 (1 _{dec})
1608:01	SubIndex 001		UDINT	RO	0x6060:00, 8

1609 DS402 RxPDO-Map Velocity offset Ch.1

Index (hex)	Name	Meaning	Data Type	Flags	Default
1609:0	DS402 RxPDO-Map Velocity offset Ch.1		USINT	RO	0x1 (1 _{dec})
1609:01	SubIndex 001		UDINT	RO	0x60b1:00, 32

160A DS402 RxPDO-Map Positive Torque limit value Ch.1

Index (hex)	Name	Meaning	Data Type	Flags	Default
160A:0	DS402 RxPDO-Map Positive Torque limit value Ch.1		USINT	RO	0x1 (1 _{dec})
160A:01	SubIndex 001		UDINT	RO	0x60e0:00, 16

160B DS402 RxPDO-Map Negative Torque limit value Ch.1

Index (hex)	Name	Meaning	Data Type	Flags	Default
160B:0	DS402 RxPDO-Map Negative Torque limit value Ch.1		USINT	RO	0x1 (1 _{dec})
160B:01	SubIndex 001		UDINT	RO	0x60e1:00, 16

1610 DS402 RxPDO-Map Digital Outputs Ch.1

Index (hex)	Name	Meaning	Data Type	Flags	Default
1610:0	DS402 RxPDO-Map Digital Outputs Ch.1		USINT	RO	0x1 (1 _{dec})
1610:01	SubIndex 001	PDO Mapping Entry for "Digital Outputs".	UDINT	RO	0x60fe:01, 32

1660 DS402 RxPDO-Map Outputs Ch.1

Index (hex)	Name	Meaning	Data Type	Flags	Default
1660:0	DS402 RxPDO-Map Outputs Ch.1		USINT	RO	0x12 (18 _{dec})
1660:01	SubIndex 001		UDINT	RO	0x0000:00, 1
1660:02	SubIndex 002	PDO Mapping Entry for "DMC__FeedbackControl__Enable latch extern on positive edge".	UDINT	RO	0x2104:02, 1
1660:03	SubIndex 003	PDO Mapping Entry for "DMC__FeedbackControl__Set counter".	UDINT	RO	0x2104:03, 1
1660:04	SubIndex 004	PDO Mapping Entry for "DMC__FeedbackControl__Enable latch extern on negative edge".	UDINT	RO	0x2104:04, 1
1660:05	SubIndex 005		UDINT	RO	0x0000:00, 12
1660:06	SubIndex 006	PDO Mapping Entry for "DMC__DriveControl__Enable".	UDINT	RO	0x2104:11, 1
1660:07	SubIndex 007	PDO Mapping Entry for "DMC__DriveControl__Reset".	UDINT	RO	0x2104:12, 1
1660:08	SubIndex 008		UDINT	RO	0x0000:00, 14
1660:09	SubIndex 009	PDO Mapping Entry for "DMC__PositioningControl__Execute".	UDINT	RO	0x2104:21, 1
1660:0A	SubIndex 010	PDO Mapping Entry for "DMC__PositioningControl__Emergency stop".	UDINT	RO	0x2104:22, 1
1660:0B	SubIndex 011		UDINT	RO	0x0000:00, 14
1660:0C	SubIndex 012	PDO Mapping Entry for "DMC__Set counter value".	UDINT	RO	0x2104:31, 64
1660:0D	SubIndex 013	PDO Mapping Entry for "DMC__Target position".	UDINT	RO	0x2104:32, 64
1660:0E	SubIndex 014	PDO Mapping Entry for "DMC__Target velocity".	UDINT	RO	0x2104:33, 16
1660:0F	SubIndex 015	PDO Mapping Entry for "DMC__Start type".	UDINT	RO	0x2104:34, 16
1660:10	SubIndex 016	PDO Mapping Entry for "DMC__Target acceleration".	UDINT	RO	0x2104:35, 16
1660:11	SubIndex 017	PDO Mapping Entry for "DMC__Target deceleration".	UDINT	RO	0x2104:36, 16
1660:12	SubIndex 018		UDINT	RO	0x0000:00, 80

1661 DS402 RxPDO-Map Outputs 32 Bit Ch.1

Index (hex)	Name	Meaning	Data Type	Flags	Default
1661:0	DS402 RxPDO-Map Outputs 32 Bit Ch.1		USINT	RO	0x14 (20 _{dec})
1661:01	SubIndex 001		UDINT	RO	0x0000:00, 1
1661:02	SubIndex 002	PDO Mapping Entry for "DMC__FeedbackControl__Enable latch extern on positive edge".	UDINT	RO	0x2104:02, 1
1661:03	SubIndex 003	PDO Mapping Entry for "DMC__FeedbackControl__Set counter".	UDINT	RO	0x2104:03, 1
1661:04	SubIndex 004	PDO Mapping Entry for "DMC__FeedbackControl__Enable latch extern on negative edge".	UDINT	RO	0x2104:04, 1
1661:05	SubIndex 005		UDINT	RO	0x0000:00, 12
1661:06	SubIndex 006	PDO Mapping Entry for "DMC__DriveControl__Enable".	UDINT	RO	0x2104:11, 1
1661:07	SubIndex 007	PDO Mapping Entry for "DMC__DriveControl__Reset".	UDINT	RO	0x2104:12, 1
1661:08	SubIndex 008		UDINT	RO	0x0000:00, 14
1661:09	SubIndex 009	PDO Mapping Entry for "DMC__PositioningControl__Execute".	UDINT	RO	0x2104:21, 1
1661:0A	SubIndex 010	PDO Mapping Entry for "DMC__PositioningControl__Emergency stop".	UDINT	RO	0x2104:22, 1
1661:0B	SubIndex 011		UDINT	RO	0x0000:00, 14
1661:0C	SubIndex 012	PDO Mapping Entry for "DMC__Set counter value".	UDINT	RO	0x2104:31, 32
1661:0D	SubIndex 013		UDINT	RO	0x0000:00, 32
1661:0E	SubIndex 014	PDO Mapping Entry for "DMC__Target position".	UDINT	RO	0x2104:32, 32
1661:0F	SubIndex 015		UDINT	RO	0x0000:00, 32
1661:10	SubIndex 016	PDO Mapping Entry for "DMC__Target velocity".	UDINT	RO	0x2104:33, 16
1661:11	SubIndex 017	PDO Mapping Entry for "DMC__Start type".	UDINT	RO	0x2104:34, 16
1661:12	SubIndex 018	PDO Mapping Entry for "DMC__Target acceleration".	UDINT	RO	0x2104:35, 16
1661:13	SubIndex 019	PDO Mapping Entry for "DMC__Target deceleration".	UDINT	RO	0x2104:36, 16
1661:14	SubIndex 020		UDINT	RO	0x0000:00, 80

1670 DS402 RxPDO-Map Dynamic Outputs Ch.1

Index (hex)	Name	Meaning	Data Type	Flags	Default
1670:0	DS402 RxPDO-Map Dynamic Outputs Ch.1		USINT	RO	0x1 (1 _{dec})
1670:01	SubIndex 001	PDO Mapping Entry for "Dynoutput cycle counter".	UDINT	RW	0x200b:04, 8
1670:02	SubIndex 002	-	UDINT	RW	-
1670:03	SubIndex 003	-	UDINT	RW	-
...
1670:FD	SubIndex 253	-	UDINT	RW	-
1670:FE	SubIndex 254	-	UDINT	RW	-
1670:FF	SubIndex 255	-	UDINT	RW	-

1680 DS402 RxPDO-Map Controlword Ch.2

Index (hex)	Name	Meaning	Data Type	Flags	Default
1680:0	DS402 RxPDO-Map Controlword Ch.2		USINT	RO	0x1 (1 _{dec})
1680:01	SubIndex 001		UDINT	RO	0x6840:00, 16

1681 DS402 RxPDO-Map Target velocity Ch.2

Index (hex)	Name	Meaning	Data Type	Flags	Default
1681:0	DS402 RxPDO-Map Target velocity Ch.2		USINT	RO	0x1 (1 _{dec})
1681:01	SubIndex 001		UDINT	RO	0x68ff:00, 32

1682 DS402 RxPDO-Map Target torque Ch.2

Index (hex)	Name	Meaning	Data Type	Flags	Default
1682:0	DS402 RxPDO-Map Target torque Ch.2		USINT	RO	0x1 (1 _{dec})
1682:01	SubIndex 001		UDINT	RO	0x6871:00, 16

1683 DS402 RxPDO-Map Commutation angle Ch.2

Index (hex)	Name	Meaning	Data Type	Flags	Default
1683:0	DS402 RxPDO-Map Commutation angle Ch.2		USINT	RO	0x1 (1 _{dec})
1683:01	SubIndex 001		UDINT	RO	0x68ea:00, 16

1684 DS402 RxPDO-Map Torque limitation Ch.2

Index (hex)	Name	Meaning	Data Type	Flags	Default
1684:0	DS402 RxPDO-Map Torque limitation Ch.2		USINT	RO	0x1 (1 _{dec})
1684:01	SubIndex 001		UDINT	RO	0x6872:00, 16

1685 DS402 RxPDO-Map Torque offset Ch.2

Index (hex)	Name	Meaning	Data Type	Flags	Default
1685:0	DS402 RxPDO-Map Torque offset Ch.2		USINT	RO	0x1 (1 _{dec})
1685:01	SubIndex 001		UDINT	RO	0x68b2:00, 16

1686 DS402 RxPDO-Map Target position Ch.2

Index (hex)	Name	Meaning	Data Type	Flags	Default
1686:0	DS402 RxPDO-Map Target position Ch.2		USINT	RO	0x1 (1 _{dec})
1686:01	SubIndex 001		UDINT	RO	0x687a:00, 32

1687 DS402 RxPDO-Map Touch probe function Ch.2

Index (hex)	Name	Meaning	Data Type	Flags	Default
1687:0	DS402 RxPDO-Map Touch probe function Ch.2		USINT	RO	0x1 (1 _{dec})
1687:01	SubIndex 001		UDINT	RO	0x68b8:00, 16

1688 DS402 RxPDO-Map Modes of operation Ch.2

Index (hex)	Name	Meaning	Data Type	Flags	Default
1688:0	DS402 RxPDO-Map Modes of operation Ch.2		USINT	RO	0x1 (1 _{dec})
1688:01	SubIndex 001		UDINT	RO	0x6860:00, 8

1689 DS402 RxPDO-Map Velocity offset Ch.2

Index (hex)	Name	Meaning	Data Type	Flags	Default
1689:0	DS402 RxPDO-Map Velocity offset Ch.2		USINT	RO	0x1 (1 _{dec})
1689:01	SubIndex 001		UDINT	RO	0x68b1:00, 32

168A DS402 RxPDO-Map Positive Torque limit value Ch.2

Index (hex)	Name	Meaning	Data Type	Flags	Default
168A:0	DS402 RxPDO-Map Positive Torque limit value Ch.2		USINT	RO	0x1 (1 _{dec})
168A:01	SubIndex 001		UDINT	RO	0x68e0:00, 16

168B DS402 RxPDO-Map Negative Torque limit value Ch.2

Index (hex)	Name	Meaning	Data Type	Flags	Default
168B:0	DS402 RxPDO-Map Negative Torque limit value Ch.2		USINT	RO	0x1 (1 _{dec})
168B:01	SubIndex 001		UDINT	RO	0x68e1:00, 16

1690 DS402 RxPDO-Map Digital Outputs Ch.2

Index (hex)	Name	Meaning	Data Type	Flags	Default
1690:0	DS402 RxPDO-Map Digital Outputs Ch.2		USINT	RO	0x1 (1 _{dec})
1690:01	SubIndex 001	PDO Mapping Entry for "Digital Outputs".	UDINT	RO	0x68fe:01, 32

16E0 DS402 RxPDO-Map Outputs Ch.2

Index (hex)	Name	Meaning	Data Type	Flags	Default
16E0:0	DS402 RxPDO-Map Outputs Ch.2		USINT	RO	0x12 (18 _{dec})
16E0:01	SubIndex 001		UDINT	RO	0x0000:00, 1
16E0:02	SubIndex 002	PDO Mapping Entry for "DMC__FeedbackControl__Enable latch extern on positive edge".	UDINT	RO	0x2904:02, 1
16E0:03	SubIndex 003	PDO Mapping Entry for "DMC__FeedbackControl__Set counter".	UDINT	RO	0x2904:03, 1
16E0:04	SubIndex 004	PDO Mapping Entry for "DMC__FeedbackControl__Enable latch extern on negative edge".	UDINT	RO	0x2904:04, 1
16E0:05	SubIndex 005		UDINT	RO	0x0000:00, 12
16E0:06	SubIndex 006	PDO Mapping Entry for "DMC__DriveControl__Enable".	UDINT	RO	0x2904:11, 1
16E0:07	SubIndex 007	PDO Mapping Entry for "DMC__DriveControl__Reset".	UDINT	RO	0x2904:12, 1
16E0:08	SubIndex 008		UDINT	RO	0x0000:00, 14
16E0:09	SubIndex 009	PDO Mapping Entry for "DMC__PositioningControl__Execute".	UDINT	RO	0x2904:21, 1
16E0:0A	SubIndex 010	PDO Mapping Entry for "DMC__PositioningControl__Emergency stop".	UDINT	RO	0x2904:22, 1
16E0:0B	SubIndex 011		UDINT	RO	0x0000:00, 14
16E0:0C	SubIndex 012	PDO Mapping Entry for "DMC__Set counter value".	UDINT	RO	0x2904:31, 64
16E0:0D	SubIndex 013	PDO Mapping Entry for "DMC__Target position".	UDINT	RO	0x2904:32, 64
16E0:0E	SubIndex 014	PDO Mapping Entry for "DMC__Target velocity".	UDINT	RO	0x2904:33, 16
16E0:0F	SubIndex 015	PDO Mapping Entry for "DMC__Start type".	UDINT	RO	0x2904:34, 16
16E0:10	SubIndex 016	PDO Mapping Entry for "DMC__Target acceleration".	UDINT	RO	0x2904:35, 16
16E0:11	SubIndex 017	PDO Mapping Entry for "DMC__Target deceleration".	UDINT	RO	0x2904:36, 16
16E0:12	SubIndex 018		UDINT	RO	0x0000:00, 80

16E1 DS402 RxPDO-Map Outputs 32 Bit Ch.2

Index (hex)	Name	Meaning	Data Type	Flags	Default
16E1:0	DS402 RxPDO-Map Outputs 32 Bit Ch.2		USINT	RO	0x14 (20 _{dec})
16E1:01	SubIndex 001		UDINT	RO	0x0000:00, 1
16E1:02	SubIndex 002	PDO Mapping Entry for "DMC__FeedbackControl__Enable latch extern on positive edge".	UDINT	RO	0x2904:02, 1
16E1:03	SubIndex 003	PDO Mapping Entry for "DMC__FeedbackControl__Set counter".	UDINT	RO	0x2904:03, 1
16E1:04	SubIndex 004	PDO Mapping Entry for "DMC__FeedbackControl__Enable latch extern on negative edge".	UDINT	RO	0x2904:04, 1
16E1:05	SubIndex 005		UDINT	RO	0x0000:00, 12
16E1:06	SubIndex 006	PDO Mapping Entry for "DMC__DriveControl__Enable".	UDINT	RO	0x2904:11, 1
16E1:07	SubIndex 007	PDO Mapping Entry for "DMC__DriveControl__Reset".	UDINT	RO	0x2904:12, 1
16E1:08	SubIndex 008		UDINT	RO	0x0000:00, 14
16E1:09	SubIndex 009	PDO Mapping Entry for "DMC__PositioningControl__Execute".	UDINT	RO	0x2904:21, 1
16E1:0A	SubIndex 010	PDO Mapping Entry for "DMC__PositioningControl__Emergency stop".	UDINT	RO	0x2904:22, 1
16E1:0B	SubIndex 011		UDINT	RO	0x0000:00, 14
16E1:0C	SubIndex 012	PDO Mapping Entry for "DMC__Set counter value".	UDINT	RO	0x2904:31, 32
16E1:0D	SubIndex 013		UDINT	RO	0x0000:00, 32
16E1:0E	SubIndex 014	PDO Mapping Entry for "DMC__Target position".	UDINT	RO	0x2904:32, 32
16E1:0F	SubIndex 015		UDINT	RO	0x0000:00, 32
16E1:10	SubIndex 016	PDO Mapping Entry for "DMC__Target velocity".	UDINT	RO	0x2904:33, 16
16E1:11	SubIndex 017	PDO Mapping Entry for "DMC__Start type".	UDINT	RO	0x2904:34, 16
16E1:12	SubIndex 018	PDO Mapping Entry for "DMC__Target acceleration".	UDINT	RO	0x2904:35, 16
16E1:13	SubIndex 019	PDO Mapping Entry for "DMC__Target deceleration".	UDINT	RO	0x2904:36, 16
16E1:14	SubIndex 020		UDINT	RO	0x0000:00, 80

16F0 DS402 RxPDO-Map Dynamic Outputs Ch.2

Index (hex)	Name	Meaning	Data Type	Flags	Default
16F0:0	DS402 RxPDO-Map Dynamic Outputs Ch.2		USINT	RO	0x1 (1 _{dec})
16F0:01	SubIndex 001	PDO Mapping Entry for "Dynoutput cycle counter".	UDINT	RW	0x280b:04, 8
16F0:02	SubIndex 002	-	UDINT	RW	-
16F0:03	SubIndex 003	-	UDINT	RW	-
...
16F0:FD	SubIndex 253	-	UDINT	RW	-
16F0:FE	SubIndex 254	-	UDINT	RW	-
16F0:FF	SubIndex 255	-	UDINT	RW	-

1860 DS402 TxPDO-Par Inputs Ch.1

Index (hex)	Name	Meaning	Data Type	Flags	Default
1860:0	DS402 TxPDO-Par Inputs Ch.1		USINT	RO	0x6 (6 _{dec})
1860:06	Exclude TxPDOs		ARRAY [0..1] OF BYTE	RO	[611a]

1861 DS402 TxPDO-Par Inputs 32 Bit Ch.1

Index (hex)	Name	Meaning	Data Type	Flags	Default
1861:0	DS402 TxPDO-Par Inputs 32 Bit Ch.1		USINT	RO	0x6 (6 _{dec})
1861:06	Exclude TxPDOs		ARRAY [0..1] OF BYTE	RO	[601a]

18E0 DS402 TxPDO-Par Inputs Ch.2

Index (hex)	Name	Meaning	Data Type	Flags	Default
18E0:0	DS402 TxPDO-Par Inputs Ch.2		USINT	RO	0x6 (6 _{dec})
18E0:06	Exclude TxPDOs		ARRAY [0..1] OF BYTE	RO	[e11a]

18E1 DS402 TxPDO-Par Inputs 32 Bit Ch.2

Index (hex)	Name	Meaning	Data Type	Flags	Default
18E1:0	DS402 TxPDO-Par Inputs 32 Bit Ch.2		USINT	RO	0x6 (6 _{dec})
18E1:06	Exclude TxPDOs		ARRAY [0..1] OF BYTE	RO	[e01a]

1A00 DS402 TxPDO-Map Position actual value Ch.1

Index (hex)	Name	Meaning	Data Type	Flags	Default
1A00:0	DS402 TxPDO-Map Position actual value Ch.1		USINT	RO	0x1 (1 _{dec})
1A00:01	SubIndex 001		UDINT	RO	0x6064:00, 32

1A01 DS402 TxPDO-Map Statusword Ch.1

Index (hex)	Name	Meaning	Data Type	Flags	Default
1A01:0	DS402 TxPDO-Map Statusword Ch.1		USINT	RO	0x1 (1 _{dec})
1A01:01	SubIndex 001		UDINT	RO	0x6041:00, 16

1A02 DS402 TxPDO-Map Velocity actual value Ch.1

Index (hex)	Name	Meaning	Data Type	Flags	Default
1A02:0	DS402 TxPDO-Map Velocity actual value Ch.1		USINT	RO	0x1 (1 _{dec})
1A02:01	SubIndex 001		UDINT	RO	0x606c:00, 32

1A03 DS402 TxPDO-Map Torque actual value Ch.1

Index (hex)	Name	Meaning	Data Type	Flags	Default
1A03:0	DS402 TxPDO-Map Torque actual value Ch.1		USINT	RO	0x1 (1 _{dec})
1A03:01	SubIndex 001		UDINT	RO	0x6077:00, 16

1A04 DS402 TxPDO-Map Info data 1 Ch.1

Index (hex)	Name	Meaning	Data Type	Flags	Default
1A04:0	DS402 TxPDO-Map Info data 1 Ch.1		USINT	RO	0x1 (1 _{dec})
1A04:01	SubIndex 001	PDO Mapping Entry for "Info data 1".	UDINT	RW	0x2008:01, 16
1A04:02	SubIndex 002	-	UDINT	RW	-
1A04:03	SubIndex 003	-	UDINT	RW	-
1A04:04	SubIndex 004	-	UDINT	RW	-
1A04:05	SubIndex 005	-	UDINT	RW	-
1A04:06	SubIndex 006	-	UDINT	RW	-
1A04:07	SubIndex 007	-	UDINT	RW	-
1A04:08	SubIndex 008	-	UDINT	RW	-
1A04:09	SubIndex 009	-	UDINT	RW	-
1A04:0A	SubIndex 010	-	UDINT	RW	-
1A04:0B	SubIndex 011	-	UDINT	RW	-
1A04:0C	SubIndex 012	-	UDINT	RW	-
1A04:0D	SubIndex 013	-	UDINT	RW	-
1A04:0E	SubIndex 014	-	UDINT	RW	-
1A04:0F	SubIndex 015	-	UDINT	RW	-
1A04:10	SubIndex 016	-	UDINT	RW	-

1A05 DS402 TxPDO-Map Info data 2 Ch.1

Index (hex)	Name	Meaning	Data Type	Flags	Default
1A05:0	DS402 TxPDO-Map Info data 2 Ch.1		USINT	RO	0x1 (1 _{dec})
1A05:01	SubIndex 001	PDO Mapping Entry for "Info data 2".	UDINT	RW	0x2008:02, 16
1A05:02	SubIndex 002	-	UDINT	RW	-
1A05:03	SubIndex 003	-	UDINT	RW	-
1A05:04	SubIndex 004	-	UDINT	RW	-
1A05:05	SubIndex 005	-	UDINT	RW	-
1A05:06	SubIndex 006	-	UDINT	RW	-
1A05:07	SubIndex 007	-	UDINT	RW	-
1A05:08	SubIndex 008	-	UDINT	RW	-
1A05:09	SubIndex 009	-	UDINT	RW	-
1A05:0A	SubIndex 010	-	UDINT	RW	-
1A05:0B	SubIndex 011	-	UDINT	RW	-
1A05:0C	SubIndex 012	-	UDINT	RW	-
1A05:0D	SubIndex 013	-	UDINT	RW	-
1A05:0E	SubIndex 014	-	UDINT	RW	-
1A05:0F	SubIndex 015	-	UDINT	RW	-
1A05:10	SubIndex 016	-	UDINT	RW	-

1A06 DS402 TxPDO-Map Following error actual value Ch.1

Index (hex)	Name	Meaning	Data Type	Flags	Default
1A06:0	DS402 TxPDO-Map Following error actual value Ch.1		USINT	RO	0x1 (1 _{dec})
1A06:01	SubIndex 001		UDINT	RO	0x60f4:00, 32

1A07 DS402 TxPDO-Map Touch probe status Ch.1

Index (hex)	Name	Meaning	Data Type	Flags	Default
1A07:0	DS402 TxPDO-Map Touch probe status Ch.1		USINT	RO	0x1 (1 _{dec})
1A07:01	SubIndex 001		UDINT	RO	0x60b9:00, 16

1A08 DS402 TxPDO-Map Touch probe 1 positive edge Ch.1

Index (hex)	Name	Meaning	Data Type	Flags	Default
1A08:0	DS402 TxPDO-Map Touch probe 1 positive edge Ch.1		USINT	RO	0x1 (1 _{dec})
1A08:01	SubIndex 001		UDINT	RO	0x60ba:00, 32

1A09 DS402 TxPDO-Map Touch probe 1 negative edge Ch.1

Index (hex)	Name	Meaning	Data Type	Flags	Default
1A09:0	DS402 TxPDO-Map Touch probe 1 negative edge Ch.1		USINT	RO	0x1 (1 _{dec})
1A09:01	SubIndex 001		UDINT	RO	0x60bb:00, 32

1A0A DS402 TxPDO-Map Touch probe 2 positive edge Ch.1

Index (hex)	Name	Meaning	Data Type	Flags	Default
1A0A:0	DS402 TxPDO-Map Touch probe 2 positive edge Ch.1		USINT	RO	0x1 (1 _{dec})
1A0A:01	SubIndex 001		UDINT	RO	0x60bc:00, 32

1A0B DS402 TxPDO-Map Touch probe 2 negative edge Ch.1

Index (hex)	Name	Meaning	Data Type	Flags	Default
1A0B:0	DS402 TxPDO-Map Touch probe 2 negative edge Ch.1		USINT	RO	0x1 (1 _{dec})
1A0B:01	SubIndex 001		UDINT	RO	0x60bd:00, 32

1A0C DS402 TxPDO-Map TxPDO Data Invalid Ch.1

Index (hex)	Name	Meaning	Data Type	Flags	Default
1A0C:0	DS402 TxPDO-Map TxPDO Data Invalid Ch.1		USINT	RO	0x3 (3 _{dec})
1A0C:01	SubIndex 001		UDINT	RO	0x0000:00, 1
1A0C:02	SubIndex 002	PDO Mapping Entry for "Position actual value".	UDINT	RO	0x603e:02, 1
1A0C:03	SubIndex 003		UDINT	RO	0x0000:00, 14

1A0D DS402 TxPDO-Map Info data 3 Ch.1

Index (hex)	Name	Meaning	Data Type	Flags	Default
1A0D:0	DS402 TxPDO-Map Info data 3 Ch.1		USINT	RO	0x1 (1 _{dec})
1A0D:01	SubIndex 001	PDO Mapping Entry for "Info data 3".	UDINT	RW	0x2008:03, 16
1A0D:02	SubIndex 002	-	UDINT	RW	-
1A0D:03	SubIndex 003	-	UDINT	RW	-
1A0D:04	SubIndex 004	-	UDINT	RW	-
1A0D:05	SubIndex 005	-	UDINT	RW	-
1A0D:06	SubIndex 006	-	UDINT	RW	-
1A0D:07	SubIndex 007	-	UDINT	RW	-
1A0D:08	SubIndex 008	-	UDINT	RW	-
1A0D:09	SubIndex 009	-	UDINT	RW	-
1A0D:0A	SubIndex 010	-	UDINT	RW	-
1A0D:0B	SubIndex 011	-	UDINT	RW	-
1A0D:0C	SubIndex 012	-	UDINT	RW	-
1A0D:0D	SubIndex 013	-	UDINT	RW	-
1A0D:0E	SubIndex 014	-	UDINT	RW	-
1A0D:0F	SubIndex 015	-	UDINT	RW	-
1A0D:10	SubIndex 016	-	UDINT	RW	-

1A0E DS402 TxPDO-Map Modes of operation display Ch.1

Index (hex)	Name	Meaning	Data Type	Flags	Default
1A0E:0	DS402 TxPDO-Map Modes of operation display Ch.1		USINT	RO	0x1 (1 _{dec})
1A0E:01	SubIndex 001		UDINT	RO	0x6061:00, 8

1A10 DS402 TxPDO-Map Digital Inputs Ch.1

Index (hex)	Name	Meaning	Data Type	Flags	Default
1A10:0	DS402 TxPDO-Map Digital Inputs Ch.1		USINT	RO	0x1 (1 _{dec})
1A10:01	SubIndex 001		UDINT	RO	0x60fd:00, 32

1A11 DS402 TxPDO-Map Touch probe time stamp 1 positive value Ch.1

Index (hex)	Name	Meaning	Data Type	Flags	Default
1A11:0	DS402 TxPDO-Map Touch probe time stamp 1 positive value Ch.1		USINT	RO	0x1 (1 _{dec})
1A11:01	SubIndex 001		UDINT	RO	0x60d1:00, 32

1A12 DS402 TxPDO-Map Touch probe time stamp 1 negative value Ch.1

Index (hex)	Name	Meaning	Data Type	Flags	Default
1A12:0	DS402 TxPDO-Map Touch probe time stamp 1 negative value Ch.1		USINT	RO	0x1 (1 _{dec})
1A12:01	SubIndex 001		UDINT	RO	0x60d2:00, 32

1A13 DS402 TxPDO-Map Touch probe time stamp 2 positive value Ch.1

Index (hex)	Name	Meaning	Data Type	Flags	Default
1A13:0	DS402 TxPDO-Map Touch probe time stamp 2 positive value Ch.1		USINT	RO	0x1 (1 _{dec})
1A13:01	SubIndex 001		UDINT	RO	0x60d3:00, 32

1A14 DS402 TxPDO-Map Touch probe time stamp 2 negative value Ch.1

Index (hex)	Name	Meaning	Data Type	Flags	Default
1A14:0	DS402 TxPDO-Map Touch probe time stamp 2 negative value Ch.1		USINT	RO	0x1 (1 _{dec})
1A14:01	SubIndex 001		UDINT	RO	0x60d4:00, 32

1A60 DS402 TxPDO-Map Inputs Ch.1

Index (hex)	Name	Meaning	Data Type	Flags	Default
1A60:0	DS402 TxPDO-Map Inputs Ch.1		USINT	RO	0x26 (38 _{dec})
1A60:01	SubIndex 001		UDINT	RO	0x0000:00, 1
1A60:02	SubIndex 002	PDO Mapping Entry for "DMC__FeedbackStatus__Latch extern valid".	UDINT	RO	0x2100:02, 1
1A60:03	SubIndex 003	PDO Mapping Entry for "DMC__FeedbackStatus__Set counter done".	UDINT	RO	0x2100:03, 1
1A60:04	SubIndex 004		UDINT	RO	0x0000:00, 9
1A60:05	SubIndex 005	PDO Mapping Entry for "DMC__FeedbackStatus__Status of extern latch".	UDINT	RO	0x2100:0d, 1
1A60:06	SubIndex 006		UDINT	RO	0x0000:00, 3
1A60:07	SubIndex 007	PDO Mapping Entry for "DMC__DriveStatus__Ready to enable".	UDINT	RO	0x2100:11, 1
1A60:08	SubIndex 008	PDO Mapping Entry for "DMC__DriveStatus__Ready".	UDINT	RO	0x2100:12, 1
1A60:09	SubIndex 009	PDO Mapping Entry for "DMC__DriveStatus__Warning".	UDINT	RO	0x2100:13, 1
1A60:0A	SubIndex 010	PDO Mapping Entry for "DMC__DriveStatus__Error".	UDINT	RO	0x2100:14, 1
1A60:0B	SubIndex 011	PDO Mapping Entry for "DMC__DriveStatus__Moving positive".	UDINT	RO	0x2100:15, 1
1A60:0C	SubIndex 012	PDO Mapping Entry for "DMC__DriveStatus__Moving negative".	UDINT	RO	0x2100:16, 1
1A60:0D	SubIndex 013		UDINT	RO	0x0000:00, 5
1A60:0E	SubIndex 014	PDO Mapping Entry for "DMC__DriveStatus__Digital input 1".	UDINT	RO	0x2100:1c, 1
1A60:0F	SubIndex 015	PDO Mapping Entry for "DMC__DriveStatus__Digital input 2".	UDINT	RO	0x2100:1d, 1
1A60:10	SubIndex 016		UDINT	RO	0x0000:00, 3
1A60:11	SubIndex 017	PDO Mapping Entry for "DMC__PositioningStatus__Busy".	UDINT	RO	0x2100:21, 1
1A60:12	SubIndex 018	PDO Mapping Entry for "DMC__PositioningStatus__In-Target".	UDINT	RO	0x2100:22, 1
1A60:13	SubIndex 019	PDO Mapping Entry for "DMC__PositioningStatus__Warning".	UDINT	RO	0x2100:23, 1
1A60:14	SubIndex 020	PDO Mapping Entry for "DMC__PositioningStatus__Error".	UDINT	RO	0x2100:24, 1
1A60:15	SubIndex 021	PDO Mapping Entry for "DMC__PositioningStatus__Calibrated".	UDINT	RO	0x2100:25, 1
1A60:16	SubIndex 022	PDO Mapping Entry for "DMC__PositioningStatus__Accelerate".	UDINT	RO	0x2100:26, 1
1A60:17	SubIndex 023	PDO Mapping Entry for "DMC__PositioningStatus__Decelerate".	UDINT	RO	0x2100:27, 1
1A60:18	SubIndex 024	PDO Mapping Entry for "DMC__PositioningStatus__Ready to execute".	UDINT	RO	0x2100:28, 1
1A60:19	SubIndex 025		UDINT	RO	0x0000:00, 8
1A60:1A	SubIndex 026	PDO Mapping Entry for "DMC__Set position".	UDINT	RO	0x2100:31, 64
1A60:1B	SubIndex 027	PDO Mapping Entry for "DMC__Set velocity".	UDINT	RO	0x2100:32, 16
1A60:1C	SubIndex 028	PDO Mapping Entry for "DMC__Actual drive time".	UDINT	RO	0x2100:33, 32
1A60:1D	SubIndex 029	PDO Mapping Entry for "DMC__Actual position lag".	UDINT	RO	0x2100:34, 64
1A60:1E	SubIndex 030	PDO Mapping Entry for "DMC__Actual velocity".	UDINT	RO	0x2100:35, 16
1A60:1F	SubIndex 031	PDO Mapping Entry for "DMC__Actual position".	UDINT	RO	0x2100:36, 64
1A60:20	SubIndex 032	PDO Mapping Entry for "DMC__Error id".	UDINT	RO	0x2100:37, 32
1A60:21	SubIndex 033	PDO Mapping Entry for "DMC__Input cycle counter".	UDINT	RO	0x2100:38, 8
1A60:22	SubIndex 034	PDO Mapping Entry for "DMC__Channel id".	UDINT	RO	0x2100:39, 8
1A60:23	SubIndex 035	PDO Mapping Entry for "DMC__Latch value".	UDINT	RO	0x2100:3a, 64
1A60:24	SubIndex 036	PDO Mapping Entry for "DMC__Cyclic info data 1".	UDINT	RO	0x2100:3b, 16
1A60:25	SubIndex 037	PDO Mapping Entry for "DMC__Cyclic info data 2".	UDINT	RO	0x2100:3c, 16
1A60:26	SubIndex 038		UDINT	RO	0x0000:00, 64

1A61 DS402 TxPDO-Map Inputs 32 Bit Ch.1

Index (hex)	Name	Meaning	Data Type	Flags	Default
1A61:0	DS402 TxPDO-Map Inputs 32 Bit Ch.1		USINT	RO	0x2A (42 _{dec})
1A61:01	SubIndex 001		UDINT	RO	0x0000:00, 1
1A61:02	SubIndex 002	PDO Mapping Entry for "DMC__FeedbackStatus__Latch extern valid".	UDINT	RO	0x2100:02, 1
1A61:03	SubIndex 003	PDO Mapping Entry for "DMC__FeedbackStatus__Set counter done".	UDINT	RO	0x2100:03, 1
1A61:04	SubIndex 004		UDINT	RO	0x0000:00, 9
1A61:05	SubIndex 005	PDO Mapping Entry for "DMC__FeedbackStatus__Status of extern latch".	UDINT	RO	0x2100:0d, 1
1A61:06	SubIndex 006		UDINT	RO	0x0000:00, 3
1A61:07	SubIndex 007	PDO Mapping Entry for "DMC__DriveStatus__Ready to enable".	UDINT	RO	0x2100:11, 1
1A61:08	SubIndex 008	PDO Mapping Entry for "DMC__DriveStatus__Ready".	UDINT	RO	0x2100:12, 1
1A61:09	SubIndex 009	PDO Mapping Entry for "DMC__DriveStatus__Warning".	UDINT	RO	0x2100:13, 1
1A61:0A	SubIndex 010	PDO Mapping Entry for "DMC__DriveStatus__Error".	UDINT	RO	0x2100:14, 1
1A61:0B	SubIndex 011	PDO Mapping Entry for "DMC__DriveStatus__Moving positive".	UDINT	RO	0x2100:15, 1
1A61:0C	SubIndex 012	PDO Mapping Entry for "DMC__DriveStatus__Moving negative".	UDINT	RO	0x2100:16, 1
1A61:0D	SubIndex 013		UDINT	RO	0x0000:00, 5
1A61:0E	SubIndex 014	PDO Mapping Entry for "DMC__DriveStatus__Digital input 1".	UDINT	RO	0x2100:1c, 1
1A61:0F	SubIndex 015	PDO Mapping Entry for "DMC__DriveStatus__Digital input 2".	UDINT	RO	0x2100:1d, 1
1A61:10	SubIndex 016		UDINT	RO	0x0000:00, 3
1A61:11	SubIndex 017	PDO Mapping Entry for "DMC__PositioningStatus__Busy".	UDINT	RO	0x2100:21, 1
1A61:12	SubIndex 018	PDO Mapping Entry for "DMC__PositioningStatus__In-Target".	UDINT	RO	0x2100:22, 1
1A61:13	SubIndex 019	PDO Mapping Entry for "DMC__PositioningStatus__Warning".	UDINT	RO	0x2100:23, 1
1A61:14	SubIndex 020	PDO Mapping Entry for "DMC__PositioningStatus__Error".	UDINT	RO	0x2100:24, 1
1A61:15	SubIndex 021	PDO Mapping Entry for "DMC__PositioningStatus__Calibrated".	UDINT	RO	0x2100:25, 1
1A61:16	SubIndex 022	PDO Mapping Entry for "DMC__PositioningStatus__Accelerate".	UDINT	RO	0x2100:26, 1
1A61:17	SubIndex 023	PDO Mapping Entry for "DMC__PositioningStatus__Decelerate".	UDINT	RO	0x2100:27, 1
1A61:18	SubIndex 024	PDO Mapping Entry for "DMC__PositioningStatus__Ready to execute".	UDINT	RO	0x2100:28, 1
1A61:19	SubIndex 025		UDINT	RO	0x0000:00, 8
1A61:1A	SubIndex 026	PDO Mapping Entry for "DMC__Set position".	UDINT	RO	0x2100:31, 32
1A61:1B	SubIndex 027		UDINT	RO	0x0000:00, 32
1A61:1C	SubIndex 028	PDO Mapping Entry for "DMC__Set velocity".	UDINT	RO	0x2100:32, 16
1A61:1D	SubIndex 029	PDO Mapping Entry for "DMC__Actual drive time".	UDINT	RO	0x2100:33, 32
1A61:1E	SubIndex 030	PDO Mapping Entry for "DMC__Actual position lag".	UDINT	RO	0x2100:34, 32
1A61:1F	SubIndex 031		UDINT	RO	0x0000:00, 32
1A61:20	SubIndex 032	PDO Mapping Entry for "DMC__Actual velocity".	UDINT	RO	0x2100:35, 16
1A61:21	SubIndex 033	PDO Mapping Entry for "DMC__Actual position".	UDINT	RO	0x2100:36, 32
1A61:22	SubIndex 034		UDINT	RO	0x0000:00, 32
1A61:23	SubIndex 035	PDO Mapping Entry for "DMC__Error id".	UDINT	RO	0x2100:37, 32
1A61:24	SubIndex 036	PDO Mapping Entry for "DMC__Input cycle counter".	UDINT	RO	0x2100:38, 8
1A61:25	SubIndex 037	PDO Mapping Entry for "DMC__Channel id".	UDINT	RO	0x2100:39, 8
1A61:26	SubIndex 038	PDO Mapping Entry for "DMC__Latch value".	UDINT	RO	0x2100:3a, 32
1A61:27	SubIndex 039		UDINT	RO	0x0000:00, 32
1A61:28	SubIndex 040	PDO Mapping Entry for "DMC__Cyclic info data 1".	UDINT	RO	0x2100:3b, 16

Index (hex)	Name	Meaning	Data Type	Flags	Default
1A61:29	SubIndex 041	PDO Mapping Entry for "DMC__Cyclic info data 2".	UDINT	RO	0x2100:3c, 16
1A61:2A	SubIndex 042		UDINT	RO	0x0000:00, 64

1A70 DS402 TxPDO-Map Dynamic Inputs Ch.1

Index (hex)	Name	Meaning	Data Type	Flags	Default
1A70:0	DS402 TxPDO-Map Dynamic Inputs Ch.1		USINT	RO	0x1 (1 _{dec})
1A70:01	SubIndex 001	PDO Mapping Entry for "Dyninput cycle counter".	UDINT	RW	0x2008:04, 8
1A70:02	SubIndex 002	-	UDINT	RW	-
1A70:03	SubIndex 003	-	UDINT	RW	-
...
1A70:FD	SubIndex 253	-	UDINT	RW	-
1A70:FE	SubIndex 254	-	UDINT	RW	-
1A70:FF	SubIndex 255	-	UDINT	RW	-

1A80 DS402 TxPDO-Map Position actual value Ch.2

Index (hex)	Name	Meaning	Data Type	Flags	Default
1A80:0	DS402 TxPDO-Map Position actual value Ch.2		USINT	RO	0x1 (1 _{dec})
1A80:01	SubIndex 001		UDINT	RO	0x6864:00, 32

1A81 DS402 TxPDO-Map Statusword Ch.2

Index (hex)	Name	Meaning	Data Type	Flags	Default
1A81:0	DS402 TxPDO-Map Statusword Ch.2		USINT	RO	0x1 (1 _{dec})
1A81:01	SubIndex 001		UDINT	RO	0x6841:00, 16

1A82 DS402 TxPDO-Map Velocity actual value Ch.2

Index (hex)	Name	Meaning	Data Type	Flags	Default
1A82:0	DS402 TxPDO-Map Velocity actual value Ch.2		USINT	RO	0x1 (1 _{dec})
1A82:01	SubIndex 001		UDINT	RO	0x686c:00, 32

1A83 DS402 TxPDO-Map Torque actual value Ch.2

Index (hex)	Name	Meaning	Data Type	Flags	Default
1A83:0	DS402 TxPDO-Map Torque actual value Ch.2		USINT	RO	0x1 (1 _{dec})
1A83:01	SubIndex 001		UDINT	RO	0x6877:00, 16

1A84 DS402 TxPDO-Map Info data 1 Ch.2

Index (hex)	Name	Meaning	Data Type	Flags	Default
1A84:0	DS402 TxPDO-Map Info data 1 Ch.2		USINT	RO	0x1 (1 _{dec})
1A84:01	SubIndex 001	PDO Mapping Entry for "Info data 1".	UDINT	RW	0x2808:01, 16
1A84:02	SubIndex 002	-	UDINT	RW	-
1A84:03	SubIndex 003	-	UDINT	RW	-
1A84:04	SubIndex 004	-	UDINT	RW	-
1A84:05	SubIndex 005	-	UDINT	RW	-
1A84:06	SubIndex 006	-	UDINT	RW	-
1A84:07	SubIndex 007	-	UDINT	RW	-
1A84:08	SubIndex 008	-	UDINT	RW	-
1A84:09	SubIndex 009	-	UDINT	RW	-
1A84:0A	SubIndex 010	-	UDINT	RW	-
1A84:0B	SubIndex 011	-	UDINT	RW	-
1A84:0C	SubIndex 012	-	UDINT	RW	-
1A84:0D	SubIndex 013	-	UDINT	RW	-
1A84:0E	SubIndex 014	-	UDINT	RW	-
1A84:0F	SubIndex 015	-	UDINT	RW	-
1A84:10	SubIndex 016	-	UDINT	RW	-

1A85 DS402 TxPDO-Map Info data 2 Ch.2

Index (hex)	Name	Meaning	Data Type	Flags	Default
1A85:0	DS402 TxPDO-Map Info data 2 Ch.2		USINT	RO	0x1 (1 _{dec})
1A85:01	SubIndex 001	PDO Mapping Entry for "Info data 2".	UDINT	RW	0x2808:02, 16
1A85:02	SubIndex 002	-	UDINT	RW	-
1A85:03	SubIndex 003	-	UDINT	RW	-
1A85:04	SubIndex 004	-	UDINT	RW	-
1A85:05	SubIndex 005	-	UDINT	RW	-
1A85:06	SubIndex 006	-	UDINT	RW	-
1A85:07	SubIndex 007	-	UDINT	RW	-
1A85:08	SubIndex 008	-	UDINT	RW	-
1A85:09	SubIndex 009	-	UDINT	RW	-
1A85:0A	SubIndex 010	-	UDINT	RW	-
1A85:0B	SubIndex 011	-	UDINT	RW	-
1A85:0C	SubIndex 012	-	UDINT	RW	-
1A85:0D	SubIndex 013	-	UDINT	RW	-
1A85:0E	SubIndex 014	-	UDINT	RW	-
1A85:0F	SubIndex 015	-	UDINT	RW	-
1A85:10	SubIndex 016	-	UDINT	RW	-

1A86 DS402 TxPDO-Map Following error actual value Ch.2

Index (hex)	Name	Meaning	Data Type	Flags	Default
1A86:0	DS402 TxPDO-Map Following error actual value Ch.2		USINT	RO	0x1 (1 _{dec})
1A86:01	SubIndex 001		UDINT	RO	0x68f4:00, 32

1A87 DS402 TxPDO-Map Touch probe status Ch.2

Index (hex)	Name	Meaning	Data Type	Flags	Default
1A87:0	DS402 TxPDO-Map Touch probe status Ch.2		USINT	RO	0x1 (1 _{dec})
1A87:01	SubIndex 001		UDINT	RO	0x68b9:00, 16

1A88 DS402 TxPDO-Map Touch probe 1 positive edge Ch.2

Index (hex)	Name	Meaning	Data Type	Flags	Default
1A88:0	DS402 TxPDO-Map Touch probe 1 positive edge Ch.2		USINT	RO	0x1 (1 _{dec})
1A88:01	SubIndex 001		UDINT	RO	0x68ba:00, 32

1A89 DS402 TxPDO-Map Touch probe 1 negative edge Ch.2

Index (hex)	Name	Meaning	Data Type	Flags	Default
1A89:0	DS402 TxPDO-Map Touch probe 1 negative edge Ch.2		USINT	RO	0x1 (1 _{dec})
1A89:01	SubIndex 001		UDINT	RO	0x68bb:00, 32

1A8A DS402 TxPDO-Map Touch probe 2 positive edge Ch.2

Index (hex)	Name	Meaning	Data Type	Flags	Default
1A8A:0	DS402 TxPDO-Map Touch probe 2 positive edge Ch.2		USINT	RO	0x1 (1 _{dec})
1A8A:01	SubIndex 001		UDINT	RO	0x68bc:00, 32

1A8B DS402 TxPDO-Map Touch probe 2 negative edge Ch.2

Index (hex)	Name	Meaning	Data Type	Flags	Default
1A8B:0	DS402 TxPDO-Map Touch probe 2 negative edge Ch.2		USINT	RO	0x1 (1 _{dec})
1A8B:01	SubIndex 001		UDINT	RO	0x68bd:00, 32

1A8C DS402 TxPDO-Map TxPDO Data Invalid Ch.2

Index (hex)	Name	Meaning	Data Type	Flags	Default
1A8C:0	DS402 TxPDO-Map TxPDO Data Invalid Ch.2		USINT	RO	0x3 (3 _{dec})
1A8C:01	SubIndex 001		UDINT	RO	0x0000:00, 1
1A8C:02	SubIndex 002	PDO Mapping Entry for "Position actual value".	UDINT	RO	0x683e:02, 1
1A8C:03	SubIndex 003		UDINT	RO	0x0000:00, 14

1A8D DS402 TxPDO-Map Info data 3 Ch.2

Index (hex)	Name	Meaning	Data Type	Flags	Default
1A8D:0	DS402 TxPDO-Map Info data 3 Ch.2		USINT	RO	0x1 (1 _{dec})
1A8D:01	SubIndex 001	PDO Mapping Entry for "Info data 3".	UDINT	RW	0x2808:03, 16
1A8D:02	SubIndex 002	-	UDINT	RW	-
1A8D:03	SubIndex 003	-	UDINT	RW	-
1A8D:04	SubIndex 004	-	UDINT	RW	-
1A8D:05	SubIndex 005	-	UDINT	RW	-
1A8D:06	SubIndex 006	-	UDINT	RW	-
1A8D:07	SubIndex 007	-	UDINT	RW	-
1A8D:08	SubIndex 008	-	UDINT	RW	-
1A8D:09	SubIndex 009	-	UDINT	RW	-
1A8D:0A	SubIndex 010	-	UDINT	RW	-
1A8D:0B	SubIndex 011	-	UDINT	RW	-
1A8D:0C	SubIndex 012	-	UDINT	RW	-
1A8D:0D	SubIndex 013	-	UDINT	RW	-
1A8D:0E	SubIndex 014	-	UDINT	RW	-
1A8D:0F	SubIndex 015	-	UDINT	RW	-
1A8D:10	SubIndex 016	-	UDINT	RW	-

1A8E DS402 TxPDO-Map Modes of operation display Ch.2

Index (hex)	Name	Meaning	Data Type	Flags	Default
1A8E:0	DS402 TxPDO-Map Modes of operation display Ch.2		USINT	RO	0x1 (1 _{dec})
1A8E:01	SubIndex 001		UDINT	RO	0x6861:00, 8

1A90 DS402 TxPDO-Map Digital Inputs Ch.2

Index (hex)	Name	Meaning	Data Type	Flags	Default
1A90:0	DS402 TxPDO-Map Digital Inputs Ch.2		USINT	RO	0x1 (1 _{dec})
1A90:01	SubIndex 001		UDINT	RO	0x68fd:00, 32

1A91 DS402 TxPDO-Map Touch probe time stamp 1 positive value Ch.2

Index (hex)	Name	Meaning	Data Type	Flags	Default
1A91:0	DS402 TxPDO-Map Touch probe time stamp 1 positive value Ch.2		USINT	RO	0x1 (1 _{dec})
1A91:01	SubIndex 001		UDINT	RO	0x68d1:00, 32

1A92 DS402 TxPDO-Map Touch probe time stamp 1 negative value Ch.2

Index (hex)	Name	Meaning	Data Type	Flags	Default
1A92:0	DS402 TxPDO-Map Touch probe time stamp 1 negative value Ch.2		USINT	RO	0x1 (1 _{dec})
1A92:01	SubIndex 001		UDINT	RO	0x68d2:00, 32

1A93 DS402 TxPDO-Map Touch probe time stamp 2 positive value Ch.2

Index (hex)	Name	Meaning	Data Type	Flags	Default
1A93:0	DS402 TxPDO-Map Touch probe time stamp 2 positive value Ch.2		USINT	RO	0x1 (1 _{dec})
1A93:01	SubIndex 001		UDINT	RO	0x68d3:00, 32

1A94 DS402 TxPDO-Map Touch probe time stamp 2 negative value Ch.2

Index (hex)	Name	Meaning	Data Type	Flags	Default
1A94:0	DS402 TxPDO-Map Touch probe time stamp 2 negative value Ch.2		USINT	RO	0x1 (1 _{dec})
1A94:01	SubIndex 001		UDINT	RO	0x68d4:00, 32

1AE0 DS402 TxPDO-Map Inputs Ch.2

Index (hex)	Name	Meaning	Data Type	Flags	Default
1AE0:0	DS402 TxPDO-Map Inputs Ch.2		USINT	RO	0x26 (38 _{dec})
1AE0:01	SubIndex 001		UDINT	RO	0x0000:00, 1
1AE0:02	SubIndex 002	PDO Mapping Entry for "DMC__FeedbackStatus__Latch extern valid".	UDINT	RO	0x2900:02, 1
1AE0:03	SubIndex 003	PDO Mapping Entry for "DMC__FeedbackStatus__Set counter done".	UDINT	RO	0x2900:03, 1
1AE0:04	SubIndex 004		UDINT	RO	0x0000:00, 9
1AE0:05	SubIndex 005	PDO Mapping Entry for "DMC__FeedbackStatus__Status of extern latch".	UDINT	RO	0x2900:0d, 1
1AE0:06	SubIndex 006		UDINT	RO	0x0000:00, 3
1AE0:07	SubIndex 007	PDO Mapping Entry for "DMC__DriveStatus__Ready to enable".	UDINT	RO	0x2900:11, 1
1AE0:08	SubIndex 008	PDO Mapping Entry for "DMC__DriveStatus__Ready".	UDINT	RO	0x2900:12, 1
1AE0:09	SubIndex 009	PDO Mapping Entry for "DMC__DriveStatus__Warning".	UDINT	RO	0x2900:13, 1
1AE0:0A	SubIndex 010	PDO Mapping Entry for "DMC__DriveStatus__Error".	UDINT	RO	0x2900:14, 1
1AE0:0B	SubIndex 011	PDO Mapping Entry for "DMC__DriveStatus__Moving positive".	UDINT	RO	0x2900:15, 1
1AE0:0C	SubIndex 012	PDO Mapping Entry for "DMC__DriveStatus__Moving negative".	UDINT	RO	0x2900:16, 1
1AE0:0D	SubIndex 013		UDINT	RO	0x0000:00, 5
1AE0:0E	SubIndex 014	PDO Mapping Entry for "DMC__DriveStatus__Digital input 1".	UDINT	RO	0x2900:1c, 1
1AE0:0F	SubIndex 015	PDO Mapping Entry for "DMC__DriveStatus__Digital input 2".	UDINT	RO	0x2900:1d, 1
1AE0:10	SubIndex 016		UDINT	RO	0x0000:00, 3
1AE0:11	SubIndex 017	PDO Mapping Entry for "DMC__PositioningStatus__Busy".	UDINT	RO	0x2900:21, 1
1AE0:12	SubIndex 018	PDO Mapping Entry for "DMC__PositioningStatus__In-Target".	UDINT	RO	0x2900:22, 1
1AE0:13	SubIndex 019	PDO Mapping Entry for "DMC__PositioningStatus__Warning".	UDINT	RO	0x2900:23, 1
1AE0:14	SubIndex 020	PDO Mapping Entry for "DMC__PositioningStatus__Error".	UDINT	RO	0x2900:24, 1
1AE0:15	SubIndex 021	PDO Mapping Entry for "DMC__PositioningStatus__Calibrated".	UDINT	RO	0x2900:25, 1
1AE0:16	SubIndex 022	PDO Mapping Entry for "DMC__PositioningStatus__Accelerate".	UDINT	RO	0x2900:26, 1
1AE0:17	SubIndex 023	PDO Mapping Entry for "DMC__PositioningStatus__Decelerate".	UDINT	RO	0x2900:27, 1
1AE0:18	SubIndex 024	PDO Mapping Entry for "DMC__PositioningStatus__Ready to execute".	UDINT	RO	0x2900:28, 1
1AE0:19	SubIndex 025		UDINT	RO	0x0000:00, 8
1AE0:1A	SubIndex 026	PDO Mapping Entry for "DMC__Set position".	UDINT	RO	0x2900:31, 64
1AE0:1B	SubIndex 027	PDO Mapping Entry for "DMC__Set velocity".	UDINT	RO	0x2900:32, 16
1AE0:1C	SubIndex 028	PDO Mapping Entry for "DMC__Actual drive time".	UDINT	RO	0x2900:33, 32
1AE0:1D	SubIndex 029	PDO Mapping Entry for "DMC__Actual position lag".	UDINT	RO	0x2900:34, 64
1AE0:1E	SubIndex 030	PDO Mapping Entry for "DMC__Actual velocity".	UDINT	RO	0x2900:35, 16
1AE0:1F	SubIndex 031	PDO Mapping Entry for "DMC__Actual position".	UDINT	RO	0x2900:36, 64
1AE0:20	SubIndex 032	PDO Mapping Entry for "DMC__Error id".	UDINT	RO	0x2900:37, 32
1AE0:21	SubIndex 033	PDO Mapping Entry for "DMC__Input cycle counter".	UDINT	RO	0x2900:38, 8
1AE0:22	SubIndex 034	PDO Mapping Entry for "DMC__Channel id".	UDINT	RO	0x2900:39, 8
1AE0:23	SubIndex 035	PDO Mapping Entry for "DMC__Latch value".	UDINT	RO	0x2900:3a, 64
1AE0:24	SubIndex 036	PDO Mapping Entry for "DMC__Cyclic info data 1".	UDINT	RO	0x2900:3b, 16
1AE0:25	SubIndex 037	PDO Mapping Entry for "DMC__Cyclic info data 2".	UDINT	RO	0x2900:3c, 16
1AE0:26	SubIndex 038		UDINT	RO	0x0000:00, 64

1AE1 DS402 TxPDO-Map Inputs 32 Bit Ch.2

Index (hex)	Name	Meaning	Data Type	Flags	Default
1AE1:0	DS402 TxPDO-Map Inputs 32 Bit Ch.2		USINT	RO	0x2A (42 _{dec})
1AE1:01	SubIndex 001		UDINT	RO	0x0000:00, 1
1AE1:02	SubIndex 002	PDO Mapping Entry for "DMC__FeedbackStatus__Latch extern valid".	UDINT	RO	0x2900:02, 1
1AE1:03	SubIndex 003	PDO Mapping Entry for "DMC__FeedbackStatus__Set counter done".	UDINT	RO	0x2900:03, 1
1AE1:04	SubIndex 004		UDINT	RO	0x0000:00, 9
1AE1:05	SubIndex 005	PDO Mapping Entry for "DMC__FeedbackStatus__Status of extern latch".	UDINT	RO	0x2900:0d, 1
1AE1:06	SubIndex 006		UDINT	RO	0x0000:00, 3
1AE1:07	SubIndex 007	PDO Mapping Entry for "DMC__DriveStatus__Ready to enable".	UDINT	RO	0x2900:11, 1
1AE1:08	SubIndex 008	PDO Mapping Entry for "DMC__DriveStatus__Ready".	UDINT	RO	0x2900:12, 1
1AE1:09	SubIndex 009	PDO Mapping Entry for "DMC__DriveStatus__Warning".	UDINT	RO	0x2900:13, 1
1AE1:0A	SubIndex 010	PDO Mapping Entry for "DMC__DriveStatus__Error".	UDINT	RO	0x2900:14, 1
1AE1:0B	SubIndex 011	PDO Mapping Entry for "DMC__DriveStatus__Moving positive".	UDINT	RO	0x2900:15, 1
1AE1:0C	SubIndex 012	PDO Mapping Entry for "DMC__DriveStatus__Moving negative".	UDINT	RO	0x2900:16, 1
1AE1:0D	SubIndex 013		UDINT	RO	0x0000:00, 5
1AE1:0E	SubIndex 014	PDO Mapping Entry for "DMC__DriveStatus__Digital input 1".	UDINT	RO	0x2900:1c, 1
1AE1:0F	SubIndex 015	PDO Mapping Entry for "DMC__DriveStatus__Digital input 2".	UDINT	RO	0x2900:1d, 1
1AE1:10	SubIndex 016		UDINT	RO	0x0000:00, 3
1AE1:11	SubIndex 017	PDO Mapping Entry for "DMC__PositioningStatus__Busy".	UDINT	RO	0x2900:21, 1
1AE1:12	SubIndex 018	PDO Mapping Entry for "DMC__PositioningStatus__In-Target".	UDINT	RO	0x2900:22, 1
1AE1:13	SubIndex 019	PDO Mapping Entry for "DMC__PositioningStatus__Warning".	UDINT	RO	0x2900:23, 1
1AE1:14	SubIndex 020	PDO Mapping Entry for "DMC__PositioningStatus__Error".	UDINT	RO	0x2900:24, 1
1AE1:15	SubIndex 021	PDO Mapping Entry for "DMC__PositioningStatus__Calibrated".	UDINT	RO	0x2900:25, 1
1AE1:16	SubIndex 022	PDO Mapping Entry for "DMC__PositioningStatus__Accelerate".	UDINT	RO	0x2900:26, 1
1AE1:17	SubIndex 023	PDO Mapping Entry for "DMC__PositioningStatus__Decelerate".	UDINT	RO	0x2900:27, 1
1AE1:18	SubIndex 024	PDO Mapping Entry for "DMC__PositioningStatus__Ready to execute".	UDINT	RO	0x2900:28, 1
1AE1:19	SubIndex 025		UDINT	RO	0x0000:00, 8
1AE1:1A	SubIndex 026	PDO Mapping Entry for "DMC__Set position".	UDINT	RO	0x2900:31, 32
1AE1:1B	SubIndex 027		UDINT	RO	0x0000:00, 32
1AE1:1C	SubIndex 028	PDO Mapping Entry for "DMC__Set velocity".	UDINT	RO	0x2900:32, 16
1AE1:1D	SubIndex 029	PDO Mapping Entry for "DMC__Actual drive time".	UDINT	RO	0x2900:33, 32
1AE1:1E	SubIndex 030	PDO Mapping Entry for "DMC__Actual position lag".	UDINT	RO	0x2900:34, 32
1AE1:1F	SubIndex 031		UDINT	RO	0x0000:00, 32
1AE1:20	SubIndex 032	PDO Mapping Entry for "DMC__Actual velocity".	UDINT	RO	0x2900:35, 16
1AE1:21	SubIndex 033	PDO Mapping Entry for "DMC__Actual position".	UDINT	RO	0x2900:36, 32
1AE1:22	SubIndex 034		UDINT	RO	0x0000:00, 32
1AE1:23	SubIndex 035	PDO Mapping Entry for "DMC__Error id".	UDINT	RO	0x2900:37, 32
1AE1:24	SubIndex 036	PDO Mapping Entry for "DMC__Input cycle counter".	UDINT	RO	0x2900:38, 8
1AE1:25	SubIndex 037	PDO Mapping Entry for "DMC__Channel id".	UDINT	RO	0x2900:39, 8
1AE1:26	SubIndex 038	PDO Mapping Entry for "DMC__Latch value".	UDINT	RO	0x2900:3a, 32
1AE1:27	SubIndex 039		UDINT	RO	0x0000:00, 32
1AE1:28	SubIndex 040	PDO Mapping Entry for "DMC__Cyclic info data 1".	UDINT	RO	0x2900:3b, 16

Index (hex)	Name	Meaning	Data Type	Flags	Default
1AE1:29	SubIndex 041	PDO Mapping Entry for "DMC__Cyclic info data 2".	UDINT	RO	0x2900:3c, 16
1AE1:2A	SubIndex 042		UDINT	RO	0x0000:00, 64

1AF0 DS402 TxPDO-Map Dynamic Inputs Ch.2

Index (hex)	Name	Meaning	Data Type	Flags	Default
1AF0:0	DS402 TxPDO-Map Dynamic Inputs Ch.2		USINT	RO	0x1 (1 _{dec})
1AF0:01	SubIndex 001	PDO Mapping Entry for "Dyninput cycle counter".	UDINT	RW	0x2808:04, 8
1AF0:02	SubIndex 002	-	UDINT	RW	-
1AF0:03	SubIndex 003	-	UDINT	RW	-
...
1AF0:FD	SubIndex 253	-	UDINT	RW	-
1AF0:FE	SubIndex 254	-	UDINT	RW	-
1AF0:FF	SubIndex 255	-	UDINT	RW	-

1C00 Sync manager type

Index (hex)	Name	Meaning	Data Type	Flags	Default
1C00:0	Sync manager type		USINT	RO	0x6 (6 _{dec})
1C00:01	SubIndex 001		USINT	RO	0x1 (1 _{dec})
1C00:02	SubIndex 002		USINT	RO	0x2 (2 _{dec})
1C00:03	SubIndex 003		USINT	RO	0x3 (3 _{dec})
1C00:04	SubIndex 004		USINT	RO	0x4 (4 _{dec})
1C00:05	SubIndex 005		USINT	RO	0x5 (5 _{dec})
1C00:06	SubIndex 006		USINT	RO	0x6 (6 _{dec})

1C12 RxPDO assign

Index (hex)	Name	Meaning	Data Type	Flags	Default
1C12:0	RxPDO assign		USINT	RO	0x4 (4 _{dec})
1C12:01	SubIndex 001		UINT	RW	0x16 (22 _{dec})
1C12:02	SubIndex 002		UINT	RW	0x616 (1558 _{dec})
1C12:03	SubIndex 003		UINT	RW	0x8016 (32790 _{dec})
1C12:04	SubIndex 004		UINT	RW	0x8616 (34326 _{dec})
1C12:05	SubIndex 005		UINT	RW	0x0 (0 _{dec})
1C12:06	SubIndex 006		UINT	RW	0x0 (0 _{dec})
1C12:07	SubIndex 007		UINT	RW	0x0 (0 _{dec})
1C12:08	SubIndex 008		UINT	RW	0x0 (0 _{dec})
1C12:09	SubIndex 009		UINT	RW	0x0 (0 _{dec})
1C12:0A	SubIndex 010		UINT	RW	0x0 (0 _{dec})
1C12:0B	SubIndex 011		UINT	RW	0x0 (0 _{dec})
1C12:0C	SubIndex 012		UINT	RW	0x0 (0 _{dec})
1C12:0D	SubIndex 013		UINT	RW	0x0 (0 _{dec})
1C12:0E	SubIndex 014		UINT	RW	0x0 (0 _{dec})
1C12:0F	SubIndex 015		UINT	RW	0x0 (0 _{dec})
1C12:10	SubIndex 016		UINT	RW	0x0 (0 _{dec})
1C12:11	SubIndex 017		UINT	RW	0x0 (0 _{dec})
1C12:12	SubIndex 018		UINT	RW	0x0 (0 _{dec})
1C12:13	SubIndex 019		UINT	RW	0x0 (0 _{dec})
1C12:14	SubIndex 020		UINT	RW	0x0 (0 _{dec})
1C12:15	SubIndex 021		UINT	RW	0x0 (0 _{dec})
1C12:16	SubIndex 022		UINT	RW	0x0 (0 _{dec})
1C12:17	SubIndex 023		UINT	RW	0x0 (0 _{dec})
1C12:18	SubIndex 024		UINT	RW	0x0 (0 _{dec})
1C12:19	SubIndex 025		UINT	RW	0x0 (0 _{dec})
1C12:1A	SubIndex 026		UINT	RW	0x0 (0 _{dec})
1C12:1B	SubIndex 027		UINT	RW	0x0 (0 _{dec})
1C12:1C	SubIndex 028		UINT	RW	0x0 (0 _{dec})

1C13 TxPDO assign

Index (hex)	Name	Meaning	Data Type	Flags	Default
1C13:0	TxPDO assign		USINT	RO	0x6 (6 _{dec})
1C13:01	SubIndex 001		UINT	RW	0x1A (26 _{dec})
1C13:02	SubIndex 002		UINT	RW	0x11A (282 _{dec})
1C13:03	SubIndex 003		UINT	RW	0x61A (1562 _{dec})
1C13:04	SubIndex 004		UINT	RW	0x801A (32794 _{dec})
1C13:05	SubIndex 005		UINT	RW	0x811A (33050 _{dec})
1C13:06	SubIndex 006		UINT	RW	0x861A (34330 _{dec})
1C13:07	SubIndex 007		UINT	RW	0x0 (0 _{dec})
1C13:08	SubIndex 008		UINT	RW	0x0 (0 _{dec})
1C13:09	SubIndex 009		UINT	RW	0x0 (0 _{dec})
1C13:0A	SubIndex 010		UINT	RW	0x0 (0 _{dec})
1C13:0B	SubIndex 011		UINT	RW	0x0 (0 _{dec})
1C13:0C	SubIndex 012		UINT	RW	0x0 (0 _{dec})
1C13:0D	SubIndex 013		UINT	RW	0x0 (0 _{dec})
1C13:0E	SubIndex 014		UINT	RW	0x0 (0 _{dec})
1C13:0F	SubIndex 015		UINT	RW	0x0 (0 _{dec})
1C13:10	SubIndex 016		UINT	RW	0x0 (0 _{dec})
1C13:11	SubIndex 017		UINT	RW	0x0 (0 _{dec})
1C13:12	SubIndex 018		UINT	RW	0x0 (0 _{dec})
1C13:13	SubIndex 019		UINT	RW	0x0 (0 _{dec})
1C13:14	SubIndex 020		UINT	RW	0x0 (0 _{dec})
1C13:15	SubIndex 021		UINT	RW	0x0 (0 _{dec})
1C13:16	SubIndex 022		UINT	RW	0x0 (0 _{dec})
1C13:17	SubIndex 023		UINT	RW	0x0 (0 _{dec})
1C13:18	SubIndex 024		UINT	RW	0x0 (0 _{dec})
1C13:19	SubIndex 025		UINT	RW	0x0 (0 _{dec})
1C13:1A	SubIndex 026		UINT	RW	0x0 (0 _{dec})
1C13:1B	SubIndex 027		UINT	RW	0x0 (0 _{dec})
1C13:1C	SubIndex 028		UINT	RW	0x0 (0 _{dec})
1C13:1D	SubIndex 029		UINT	RW	0x0 (0 _{dec})
1C13:1E	SubIndex 030		UINT	RW	0x0 (0 _{dec})
1C13:1F	SubIndex 031		UINT	RW	0x0 (0 _{dec})
1C13:20	SubIndex 032		UINT	RW	0x0 (0 _{dec})
1C13:21	SubIndex 033		UINT	RW	0x0 (0 _{dec})
1C13:22	SubIndex 034		UINT	RW	0x0 (0 _{dec})
1C13:23	SubIndex 035		UINT	RW	0x0 (0 _{dec})
1C13:24	SubIndex 036		UINT	RW	0x0 (0 _{dec})
1C13:25	SubIndex 037		UINT	RW	0x0 (0 _{dec})
1C13:26	SubIndex 038		UINT	RW	0x0 (0 _{dec})
1C13:27	SubIndex 039		UINT	RW	0x0 (0 _{dec})
1C13:28	SubIndex 040		UINT	RW	0x0 (0 _{dec})
1C13:29	SubIndex 041		UINT	RW	0x0 (0 _{dec})
1C13:2A	SubIndex 042		UINT	RW	0x0 (0 _{dec})

1C14 Dynamic RxPDO assign

Index (hex)	Name	Meaning	Data Type	Flags	Default
1C14:0	Dynamic RxPDO assign	-	USINT	RO	-
1C14:01	SubIndex 001		UINT	RW	0x0 (0 _{dec})
1C14:02	SubIndex 002		UINT	RW	0x0 (0 _{dec})

1C15 Dynamic TxPDO assign

Index (hex)	Name	Meaning	Data Type	Flags	Default
1C15:0	Dynamic TxPDO assign	-	USINT	RO	-
1C15:01	SubIndex 001		UINT	RW	0x0 (0 _{dec})
1C15:02	SubIndex 002		UINT	RW	0x0 (0 _{dec})

1C32 SM output parameter

Index (hex)	Name	Meaning	Data Type	Flags	Default
1C32:0	SM output parameter		USINT	RO	0x20 (32 _{dec})
1C32:01	Sync mode		UINT	RW	0x3 (3 _{dec})
1C32:02	Cycle time		UDINT	RW	0xF4240 (1000000 _{dec})
1C32:03	Shift time		UDINT	RO	0x0 (0 _{dec})
1C32:04	Sync modes supported		UINT	RO	0x812 (2066 _{dec})
1C32:05	Minimum cycle time		UDINT	RO	0x1E848 (125000 _{dec})
1C32:06	Calc and copy time		UDINT	RO	0x7530 (30000 _{dec})
1C32:07	Minimum delay time		UDINT	RO	0x7A12 (31250 _{dec})
1C32:08	Get Cycle Time		UINT	RW	0x0 (0 _{dec})
1C32:09	Maximum delay time		UDINT	RO	0x7A12 (31250 _{dec})
1C32:0A	Sync0 Cycle Time		UDINT	RO	0xF424 (62500 _{dec})
1C32:0B	SM event missed counter	-	UINT	RO	-
1C32:0C	Cycle exceeded counter	-	UINT	RO	-
1C32:0D	Shift too short counter	-	UINT	RO	-
1C32:20	Sync error	-	BOOL	RO	-

1C33 SM input parameter

Index (hex)	Name	Meaning	Data Type	Flags	Default
1C33:0	SM input parameter		USINT	RO	0x20 (32 _{dec})
1C33:01	Sync mode		UINT	RW	0x3 (3 _{dec})
1C33:02	Cycle time		UDINT	RW	0xF4240 (1000000 _{dec})
1C33:03	Shift time		UDINT	RO	0x0 (0 _{dec})
1C33:04	Sync modes supported		UINT	RO	0x12 (18 _{dec})
1C33:05	Minimum cycle time		UDINT	RO	0x1E848 (125000 _{dec})
1C33:06	Calc and copy time		UDINT	RO	0x7530 (30000 _{dec})
1C33:07	Minimum delay time		UDINT	RO	0x0 (0 _{dec})
1C33:08	Get Cycle Time		UINT	RW	0x0 (0 _{dec})
1C33:09	Maximum delay time		UDINT	RO	0x7A12 (31250 _{dec})
1C33:0A	Sync0 Cycle Time		UDINT	RO	0xF424 (62500 _{dec})
1C33:0B	SM event missed counter	-	UINT	RO	-
1C33:0C	Cycle exceeded counter	-	UINT	RO	-
1C33:0D	Shift too short counter	-	UINT	RO	-
1C33:20	Sync error	-	BOOL	RO	-

F008 Code word

Index (hex)	Name	Meaning	Data Type	Flags	Default
F008:0	Code word	-	UDINT	RO	-

F081 Download revision

Index (hex)	Name	Meaning	Data Type	Flags	Default
F081:0	Download revision		USINT	RO	0x1 (1 _{dec})
F081:01	Revision number	-	UDINT	RW	-

FB00 Command

Index (hex)	Name	Meaning	Data Type	Flags	Default
FB00:0	Command		USINT	RO	0x3 (3 _{dec})
FB00:01	Request	-	ARRAY [0..1] OF BYTE	RW	-
FB00:02	Status	-	USINT	RO	-
FB00:03	Response	-	ARRAY [0..5] OF BYTE	RO	-

FB13 DRV Key code

Index (hex)	Name	Meaning	Data Type	Flags	Default
FB13:0	DRV Key code		USINT	RO	0x1 (1 _{dec})
FB13:01	Code	-	ARRAY [0..31] OF BYTE	RW	-

FB40 Memory interface

Index (hex)	Name	Meaning	Data Type	Flags	Default
FB40:0	Memory interface		USINT	RO	0x3 (3 _{dec})
FB40:01	Address	-	UDINT	RW	-
FB40:02	Length	-	UINT	RW	-
FB40:03	Data	-	ARRAY [0..7] OF BYTE	RW	-

6 Appendix

6.1 General operating conditions

Protection rating according to IP code

The degrees of protection are defined and divided into different classes in the IEC 60529 standard (EN 60529). Degrees of protection are designated by the letters "IP" and two numerals: **IPxy**

- Numeral x: Dust protection and contact protection
- Numeral y: Protection against water

x	Meaning
0	Not protected
1	Protected against access to dangerous parts with the back of the hand. Protected against solid foreign objects of 50 mm Ø
2	Protected against access to dangerous parts with a finger. Protected against solid foreign objects of 12.5 mm Ø
3	Protected against access to dangerous parts with a tool. Protected against solid foreign objects of 2.5 mm Ø
4	Protected against access to dangerous parts with a wire. Protected against solid foreign objects of 1 mm Ø
5	Protection against access to dangerous parts with a wire. Dust-protected. Ingress of dust is not prevented completely, although the quantity of dust able to penetrate is limited to such an extent that the proper function of the device and safety are not impaired
6	Protection against access to dangerous parts with a wire. Dust-tight. No ingress of dust

y	Meaning
0	Not protected
1	Protection against vertically falling water drops
2	Protection against vertically falling water drops when enclosure tilted up to 15°
3	Protection against spraying water. Water sprayed at an angle of up to 60° on either side of the vertical shall have no harmful effects
4	Protection against splashing water. Water splashed against the enclosure from any direction shall have no harmful effects
5	Protection against water jets.
6	Protection against powerful water jets.
7	Protected against the effects of temporary immersion in water. Ingress of water in quantities causing harmful effects shall not be possible when the enclosure is immersed in water at a depth of 1 m for 30 minutes

Chemical resistance

The resistance refers to the housing of the IP67 modules and the metal parts used. In the table below you will find some typical resistances.

Type	Resistance
Water vapor	unstable at temperatures > 100 °C
Sodium hydroxide solution (ph value > 12)	stable at room temperature unstable > 40 °C
Acetic acid	unstable
Argon (technically pure)	stable

Key

- resistant: Lifetime several months
- non inherently resistant: Lifetime several weeks
- not resistant: Lifetime several hours resp. early decomposition

6.2 Version identification of EtherCAT devices

6.2.1 General notes on marking

Designation

A Beckhoff EtherCAT device has a 14-digit designation, made up of

- family key
- type
- version
- revision

Example	Family	Type	Version	Revision
EL3314-0000-0016	EL terminal 12 mm, non-pluggable connection level	3314 4-channel thermocouple terminal	0000 basic type	0016
ES3602-0010-0017	ES terminal 12 mm, pluggable connection level	3602 2-channel voltage measurement	0010 high-precision version	0017
CU2008-0000-0000	CU device	2008 8-port fast ethernet switch	0000 basic type	0000

Notes

- The elements mentioned above result in the **technical designation**. EL3314-0000-0016 is used in the example below.
- EL3314-0000 is the order identifier, in the case of “-0000” usually abbreviated to EL3314. “-0016” is the EtherCAT revision.
- The **order identifier** is made up of
 - family key (EL, EP, CU, ES, KL, CX, etc.)
 - type (3314)
 - version (-0000)
- The **revision** -0016 shows the technical progress, such as the extension of features with regard to the EtherCAT communication, and is managed by Beckhoff.
 In principle, a device with a higher revision can replace a device with a lower revision, unless specified otherwise, e.g. in the documentation.
 Associated and synonymous with each revision there is usually a description (ESI, EtherCAT Slave Information) in the form of an XML file, which is available for download from the Beckhoff web site.
 From 2014/01 the revision is shown on the outside of the IP20 terminals, see Fig. “EL2872 with revision 0022 and serial number 01200815”.
- The type, version and revision are read as decimal numbers, even if they are technically saved in hexadecimal.

6.2.2 Version identification of IP67 modules

The serial number/ data code for Beckhoff IO devices is usually the 8-digit number printed on the device or on a sticker. The serial number indicates the configuration in delivery state and therefore refers to a whole production batch, without distinguishing the individual modules of a batch.

Structure of the serial number: **KK YY FF HH**

KK - week of production (CW, calendar week)

YY - year of production

FF - firmware version

HH - hardware version

Example with serial number 12 06 3A 02:

12 - production week 12

06 - production year 2006

3A - firmware version 3A

02 - hardware version 02

Exceptions can occur in the **IP67 area**, where the following syntax can be used (see respective device documentation):

Syntax: D ww yy x y z u

D - prefix designation

ww - calendar week

yy - year

x - firmware version of the bus PCB

y - hardware version of the bus PCB

z - firmware version of the I/O PCB

u - hardware version of the I/O PCB

Example: D.22081501 calendar week 22 of the year 2008 firmware version of bus PCB: 1 hardware version of bus PCB: 5 firmware version of I/O PCB: 0 (no firmware necessary for this PCB) hardware version of I/O PCB: 1

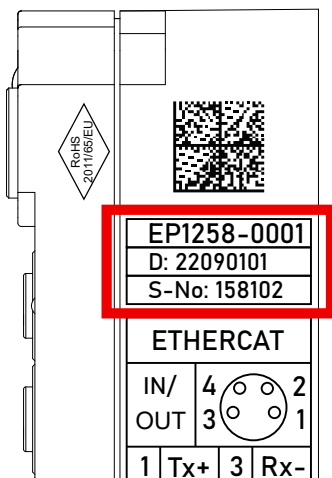

Fig. 1: EP1258-00001 IP67 EtherCAT Box with batch number/DateCode 22090101 and unique serial number 158102

6.2.3 Beckhoff Identification Code (BIC)

The Beckhoff Identification Code (BIC) is increasingly being applied to Beckhoff products to uniquely identify the product. The BIC is represented as a Data Matrix Code (DMC, code scheme ECC200), the content is based on the ANSI standard MH10.8.2-2016.

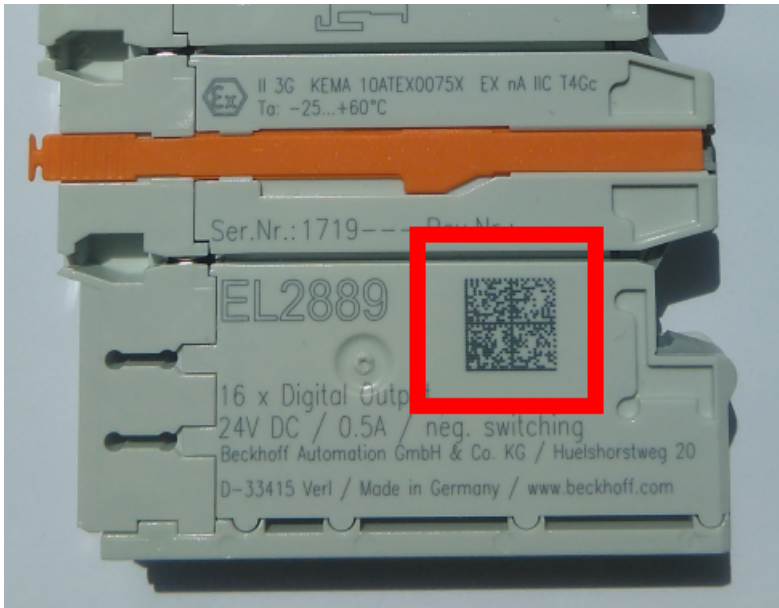

Fig. 2: BIC as data matrix code (DMC, code scheme ECC200)

The BIC will be introduced step by step across all product groups.

Depending on the product, it can be found in the following places:

- on the packaging unit
- directly on the product (if space suffices)
- on the packaging unit and the product

The BIC is machine-readable and contains information that can also be used by the customer for handling and product management.

Each piece of information can be uniquely identified using the so-called data identifier (ANSI MH10.8.2-2016). The data identifier is followed by a character string. Both together have a maximum length according to the table below. If the information is shorter, spaces are added to it.

Following information is possible, positions 1 to 4 are always present, the other according to need of production:

Position	Type of information	Explanation	Data identifier	Number of digits incl. data identifier	Example
1	Beckhoff order number	Beckhoff order number	1P	8	1P 072222
2	Beckhoff Traceability Number (BTN)	Unique serial number, see note below	SBTN	12	SBTN k4p562d7
3	Article description	Beckhoff article description, e.g. EL1008	1K	32	1K EL1809
4	Quantity	Quantity in packaging unit, e.g. 1, 10, etc.	Q	6	Q1
5	Batch number	Optional: Year and week of production	2P	14	2P 401503180016
6	ID/serial number	Optional: Present-day serial number system, e.g. with safety products	51S	12	51S 678294
7	Variant number	Optional: Product variant number on the basis of standard products	30P	12	30P F971, 2*K183
...					

Further types of information and data identifiers are used by Beckhoff and serve internal processes.

Structure of the BIC

Example of composite information from positions 1 to 4 and with the above given example value on position 6. The data identifiers are highlighted in bold font:

1P072222**SBTN**k4p562d7**1K**EL1809 **Q1** **51S**678294

Accordingly as DMC:



Fig. 3: Example DMC **1P**072222**SBTN**k4p562d7**1K**EL1809 **Q1** **51S**678294

BTN

An important component of the BIC is the Beckhoff Traceability Number (BTN, position 2). The BTN is a unique serial number consisting of eight characters that will replace all other serial number systems at Beckhoff in the long term (e.g. batch designations on IO components, previous serial number range for safety products, etc.). The BTN will also be introduced step by step, so it may happen that the BTN is not yet coded in the BIC.

NOTICE

This information has been carefully prepared. However, the procedure described is constantly being further developed. We reserve the right to revise and change procedures and documentation at any time and without prior notice. No claims for changes can be made from the information, illustrations and descriptions in this documentation.

6.2.4 Electronic access to the BIC (eBIC)

Electronic BIC (eBIC)

The Beckhoff Identification Code (BIC) is applied to the outside of Beckhoff products in a visible place. If possible, it should also be electronically readable.

The interface that the product can be electronically addressed by is crucial for the electronic readout.

EtherCAT devices (IP20, IP67)

All Beckhoff EtherCAT devices have an ESI-EEPROM which contains the EtherCAT identity with the revision number. The EtherCAT slave information, also colloquially known as the ESI/XML configuration file for the EtherCAT master, is stored in it. See the corresponding chapter in the EtherCAT system manual ([Link](#)) for the relationships.

Beckhoff also stores the eBIC in the ESI-EEPROM. The eBIC was introduced into Beckhoff IO production (terminals, box modules) in 2020; as of 2023, implementation is largely complete.

The user can electronically access the eBIC (if present) as follows:

- With all EtherCAT devices, the EtherCAT master (TwinCAT) can read the eBIC from the ESI-EEPROM
 - From TwinCAT 3.1 build 4024.11, the eBIC can be displayed in the online view.
 - To do this, check the "Show Beckhoff Identification Code (BIC)" checkbox under EtherCAT → Advanced Settings → Diagnostics:

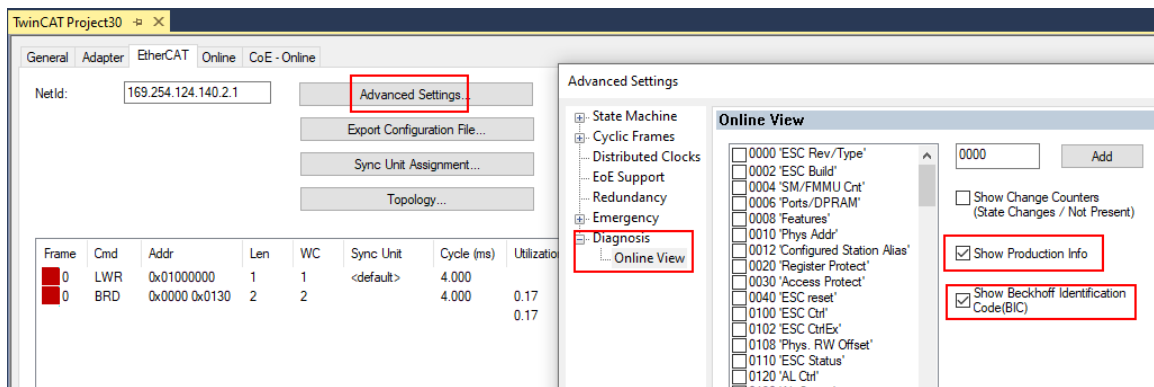

- The BTN and its contents are then displayed:

No	Addr	Name	State	CRC	Fw	Hw	Production Data	ItemNo	BTN	Description	Quantity	BatchNo	SerialNo
1	1001	Term 1 (EK1100)	OP	0,0	0	0	---						
2	1002	Term 2 (EL1018)	OP	0,0	0	0	2020 KW36 Fr	072222	k4p562d7	EL1809	1		678294
3	1003	Term 3 (EL3204)	OP	0,0	7	6	2012 KW24 Sa						
4	1004	Term 4 (EL2004)	OP	0,0	0	0	---	072223	k4p562d7	EL2004	1		678295
5	1005	Term 5 (EL1008)	OP	0,0	0	0	---						
6	1006	Term 6 (EL2008)	OP	0,0	0	12	2014 KW14 Mo						
7	1007	Term 7 (EK1110)	OP	0	1	8	2012 KW25 Mo						

- Note: As shown in the figure, the production data HW version, FW version, and production date, which have been programmed since 2012, can also be displayed with "Show production info".
- Access from the PLC: From TwinCAT 3.1. build 4024.24, the functions *FB_EcReadBIC* and *FB_EcReadBTN* for reading into the PLC are available in the Tc2_EtherCAT library from v3.3.19.0.
- EtherCAT devices with a CoE directory may also have the object 0x10E2:01 to display their own eBIC, which can also be easily accessed by the PLC:

- The device must be in PREOP/SAFEOP/OP for access:

Index	Name	Flags	Value
1000	Device type	RO	0x015E1389 (22942601)
1008	Device name	RO	ELM3704-0000
1009	Hardware version	RO	00
100A	Software version	RO	01
100B	Bootloader version	RO	J0.1.27.0
1011:0	Restore default parameters	RO	> 1 <
1018:0	Identity	RO	> 4 <
10E2:0	Manufacturer-specific Identification C...	RO	> 1 <
10E2:01	Subindex 001	RO	1P158442SBTN0008jckp1KELM3704 Q1 2P482001000016
10F0:0	Backup parameter handling	RO	> 1 <
10F3:0	Diagnosis History	RO	> 21 <
10F8	Actual Time Stamp	RO	0x170bfb277e

- The object 0x10E2 will be preferentially introduced into stock products in the course of necessary firmware revision.
- From TwinCAT 3.1. build 4024.24, the functions *FB_EcCoEReadBIC* and *FB_EcCoEReadBTN* for reading into the PLC are available in the *Tc2_EtherCAT* library from v3.3.19.0
- The following auxiliary functions are available for processing the BIC/BTN data in the PLC in *Tc2_Uilities* as of TwinCAT 3.1 build 4024.24
 - *F_SplitBIC*: The function splits the Beckhoff Identification Code (BIC) *sBICValue* into its components using known identifiers and returns the recognized substrings in the *ST_SplittedBIC* structure as a return value
 - *BIC_TO_BTN*: The function extracts the BTN from the BIC and returns it as a return value
- Note: If there is further electronic processing, the BTN is to be handled as a string(8); the identifier "SBTN" is not part of the BTN.
- Technical background
The new BIC information is written as an additional category in the ESI-EEPROM during device production. The structure of the ESI content is largely dictated by the ETG specifications, therefore the additional vendor-specific content is stored using a category in accordance with the ETG.2010. ID 03 tells all EtherCAT masters that they may not overwrite these data in the event of an update or restore the data after an ESI update.
The structure follows the content of the BIC, see here. The EEPROM therefore requires approx. 50..200 bytes of memory.
- Special cases
 - If multiple hierarchically arranged ESCs are installed in a device, only the top-level ESC carries the eBIC information.
 - If multiple non-hierarchically arranged ESCs are installed in a device, all ESCs carry the eBIC information.
 - If the device consists of several sub-devices which each have their own identity, but only the top-level device is accessible via EtherCAT, the eBIC of the top-level device is located in the CoE object directory 0x10E2:01 and the eBICs of the sub-devices follow in 0x10E2:nn.

6.3 Support and Service

Beckhoff and their partners around the world offer comprehensive support and service, making available fast and competent assistance with all questions related to Beckhoff products and system solutions.

Download finder

Our [download finder](#) contains all the files that we offer you for downloading. You will find application reports, technical documentation, technical drawings, configuration files and much more.

The downloads are available in various formats.

Beckhoff's branch offices and representatives

Please contact your Beckhoff branch office or representative for [local support and service](#) on Beckhoff products!

The addresses of Beckhoff's branch offices and representatives round the world can be found on our internet page: www.beckhoff.com

You will also find further documentation for Beckhoff components there.

Beckhoff Support

Support offers you comprehensive technical assistance, helping you not only with the application of individual Beckhoff products, but also with other, wide-ranging services:

- support
- design, programming and commissioning of complex automation systems
- and extensive training program for Beckhoff system components

Hotline: +49 5246 963-157
e-mail: support@beckhoff.com

Beckhoff Service

The Beckhoff Service Center supports you in all matters of after-sales service:

- on-site service
- repair service
- spare parts service
- hotline service

Hotline: +49 5246 963-460
e-mail: service@beckhoff.com

Beckhoff Headquarters

Beckhoff Automation GmbH & Co. KG

Huelshorstweg 20
33415 Verl
Germany

Phone: +49 5246 963-0
e-mail: info@beckhoff.com
web: www.beckhoff.com

Trademark statements

Beckhoff®, ATRO®, EtherCAT®, EtherCAT G®, EtherCAT G10®, EtherCAT P®, MX-System®, Safety over EtherCAT®, TC/BSD®, TwinCAT®, TwinCAT/BSD®, TwinSAFE®, XFC®, XPlanar® and XTS® are registered and licensed trademarks of Beckhoff Automation GmbH.

Beckhoff Automation GmbH & Co. KG
Hülshorstweg 20
33415 Verl
Germany
Phone: +49 5246 9630
info@beckhoff.com
www.beckhoff.com