

Documentation | EN

EP23xx

EtherCAT box modules with digital inputs and outputs



Table of contents

1	Foreword	7
1.1	Notes on the documentation	7
1.2	Safety instructions	8
1.3	Documentation issue status	9
2	EtherCAT Box - Introduction	10
3	Product overview	12
3.1	EP2308, EP2318, EP2328	13
3.1.1	EP2308, EP2318, EP2328 - Introduction	13
3.1.2	EP2308, EP2318 - Technical Data	15
3.1.3	EP2328 – Technical data	17
3.1.4	EP2308, EP2318, EP2328 - Scope of supply	19
3.1.5	EP2308, EP2318, EP2328 - Process image	20
3.2	EP2316-0003, EP2316-0008	21
3.2.1	EP2316-0003 - Introduction	21
3.2.2	EP2316-0008 - Introduction	22
3.2.3	EP2316-000x - Technical Data	23
3.2.4	EP2316-000x - Scope of supply	24
3.2.5	EP2316-0008 - Status LEDs	25
3.2.6	EP2316-000x - Process image	26
3.3	EP2338-000x, EP2338-100x.....	29
3.3.1	EP2338-000x, EP2338-100x - Introduction.....	29
3.3.2	EP2338-000x, EP2338-100x - Technical data	31
3.3.3	EP2338-x00x - Scope of supply	32
3.3.4	EP2338-x00x - Process image.....	33
3.4	EP2338-2002	35
3.4.1	EP2338-2002 - Introduction	35
3.4.2	EP2338-2002 - Technical data.....	36
3.4.3	EP2338-2002 - Scope of supply	37
3.4.4	EP2338-2002 - Process image	38
3.5	EP2339-0003	40
3.5.1	EP2339-0003 - Introduction	40
3.5.2	EP2339-0003 - Technical data.....	41
3.5.3	EP2339-0003 - Scope of supply	43
3.5.4	EP2339-0003 - Process image	44
3.6	EP2339-002x, EP2349-002x.....	46
3.6.1	EP23x9-0021 - Introduction	46
3.6.2	EP23x9-0022 - Introduction	47
3.6.3	EP23x9-002x - Technical data	48
3.6.4	EP23x9-002x - Scope of supply	50
3.6.5	EP23x9-002x - Process image.....	51
3.7	EP2339-0042	52
3.7.1	EP2339-0042 - Introduction	52
3.7.2	EP2339-0042 - Technical data.....	54
3.7.3	EP2339-0042 - Scope of supply	56

3.7.4	EP2339-0042 - Process image	57
3.8	EP2339-0121	58
3.8.1	EP2339-0121 - Introduction	58
3.8.2	EP2339-0121 - Technical data.....	59
3.8.3	EP2339-0121 - Scope of supply	60
3.8.4	EP2339-0121 - Process image	61
4	Mounting and connection.....	62
4.1	Mounting	62
4.1.1	EPxxxx-x001 dimensions	62
4.1.2	EPxxxx-x002 dimensions	63
4.1.3	EPxxxx-0003 dimensions.....	64
4.1.4	EPxxxx-0008 dimensions.....	65
4.1.5	EPxxxx-0x21 dimensions	66
4.1.6	EPxxxx-0022 dimensions.....	67
4.1.7	EPxxxx-0042 dimensions.....	68
4.1.8	Fixing.....	69
4.1.9	Functional earth (FE)	70
4.2	Connections	71
4.2.1	Tightening torques for plug connectors.....	71
4.2.2	EtherCAT	72
4.2.3	Supply voltages.....	74
4.2.4	Digital inputs and digital outputs	78
4.3	UL Requirements	90
4.4	ATEX notes	91
4.4.1	ATEX - Special conditions.....	91
4.4.2	BG2000 - EtherCAT Box protection enclosures.....	92
4.4.3	ATEX Documentation.....	93
4.5	Disposal	94
5	Commissioning and configuration	95
5.1	Integrating into a TwinCAT project.....	95
5.2	Switching inductive loads	96
5.3	Behavior of the outputs in case of a fault (EP2316 only)	97
5.3.1	Behavior in case of network failure	97
5.3.2	Behavior in case of short circuit	99
5.3.3	Behavior in case of lack of supply voltage	100
5.4	Restore the delivery state	101
5.5	Decommissioning.....	102
6	Appendix.....	103
6.1	General operating conditions	103
6.2	Accessories	104
6.3	Version identification of EtherCAT devices	105
6.3.1	General notes on marking.....	105
6.3.2	Version identification of IP67 modules	106
6.3.3	Beckhoff Identification Code (BIC).....	107
6.3.4	Electronic access to the BIC (eBIC).....	109

6.4 Support and Service..... 111

1 Foreword

1.1 Notes on the documentation

Intended audience

This description is only intended for the use of trained specialists in control and automation engineering who are familiar with the applicable national standards.

It is essential that the documentation and the following notes and explanations are followed when installing and commissioning these components.

The qualified personnel is obliged to always use the currently valid documentation.

The responsible staff must ensure that the application or use of the products described satisfy all the requirements for safety, including all the relevant laws, regulations, guidelines and standards.

Disclaimer

The documentation has been prepared with care. The products described are, however, constantly under development.

We reserve the right to revise and change the documentation at any time and without prior announcement.

No claims for the modification of products that have already been supplied may be made on the basis of the data, diagrams and descriptions in this documentation.

Trademarks

Beckhoff®, TwinCAT®, TwinCAT/BSD®, TC/BSD®, EtherCAT®, EtherCAT G®, EtherCAT G10®, EtherCAT P®, Safety over EtherCAT®, TwinSAFE®, XFC®, XTS® and XPlanar® are registered trademarks of and licensed by Beckhoff Automation GmbH. Other designations used in this publication may be trademarks whose use by third parties for their own purposes could violate the rights of the owners.



EtherCAT® is registered trademark and patented technology, licensed by Beckhoff Automation GmbH, Germany.

Copyright

© Beckhoff Automation GmbH & Co. KG, Germany.

The reproduction, distribution and utilization of this document as well as the communication of its contents to others without express authorization are prohibited.

Offenders will be held liable for the payment of damages. All rights reserved in the event of the grant of a patent, utility model or design.

Third-party brands

Trademarks of third parties may be used in this documentation. You can find the trademark notices here: <https://www.beckhoff.com/trademarks>

1.2 Safety instructions

Safety regulations

Please note the following safety instructions and explanations!
Product-specific safety instructions can be found on following pages or in the areas mounting, wiring, commissioning etc.

Exclusion of liability

All the components are supplied in particular hardware and software configurations appropriate for the application. Modifications to hardware or software configurations other than those described in the documentation are not permitted, and nullify the liability of Beckhoff Automation GmbH & Co. KG.

Personnel qualification

This description is only intended for trained specialists in control, automation and drive engineering who are familiar with the applicable national standards.

Signal words

The signal words used in the documentation are classified below. In order to prevent injury and damage to persons and property, read and follow the safety and warning notices.

Personal injury warnings

⚠ DANGER

Hazard with high risk of death or serious injury.

⚠ WARNING

Hazard with medium risk of death or serious injury.

⚠ CAUTION

There is a low-risk hazard that could result in medium or minor injury.

Warning of damage to property or environment

NOTICE

The environment, equipment, or data may be damaged.

Information on handling the product



This information includes, for example:
recommendations for action, assistance or further information on the product.

1.3 Documentation issue status

Version	Comment
3.8	<ul style="list-style-type: none"> • EP2338-2002 added • Technical data updated
3.7	<ul style="list-style-type: none"> • Signal interfaces updated
3.6	<ul style="list-style-type: none"> • Signal interfaces updated
3.5	<ul style="list-style-type: none"> • Signal interfaces updated
3.4	<ul style="list-style-type: none"> • Technical data updated
3.3	<ul style="list-style-type: none"> • EP2339-0121 added • Technical data updated • Dimensions updated • UL requirements updated
3.2	<ul style="list-style-type: none"> • Front page updated • Scope of delivery added
3.1	<ul style="list-style-type: none"> • EP2339-0042: Technical data and connections updated
3.0	<ul style="list-style-type: none"> • Documentation separated from EP2xxx 2.9.2 • EP2339-0042 added

Firmware and hardware versions

This documentation refers to the firmware and hardware version that was applicable at the time the documentation was written.

The module features are continuously improved and developed further. Modules having earlier production statuses cannot have the same properties as modules with the latest status. However, existing properties are retained and are not changed, so that older modules can always be replaced with new ones.

The firmware and hardware version (delivery state) can be found in the batch number (D-number) printed on the side of the EtherCAT Box.

Syntax of the batch number (D-number)

D: WW YY FF HH

WW - week of production (calendar week)

YY - year of production

FF - firmware version

HH - hardware version

Example with D no. 29 10 02 01:

29 - week of production 29

10 - year of production 2010

02 - firmware version 02

01 - hardware version 01

Further information on this topic: [Version identification of EtherCAT devices \[► 105\]](#).

2 EtherCAT Box - Introduction

The EtherCAT system has been extended with EtherCAT Box modules with protection class IP67. Through the integrated EtherCAT interface the modules can be connected directly to an EtherCAT network without an additional Coupler Box. The high-performance of EtherCAT is thus maintained into each module.

The extremely low dimensions of only 126 x 30 x 26.5 mm (h x w x d) are identical to those of the Fieldbus Box extension modules. They are thus particularly suitable for use where space is at a premium. The small mass of the EtherCAT modules facilitates applications with mobile I/O interface (e.g. on a robot arm). The EtherCAT connection is established via screened M8 connectors.

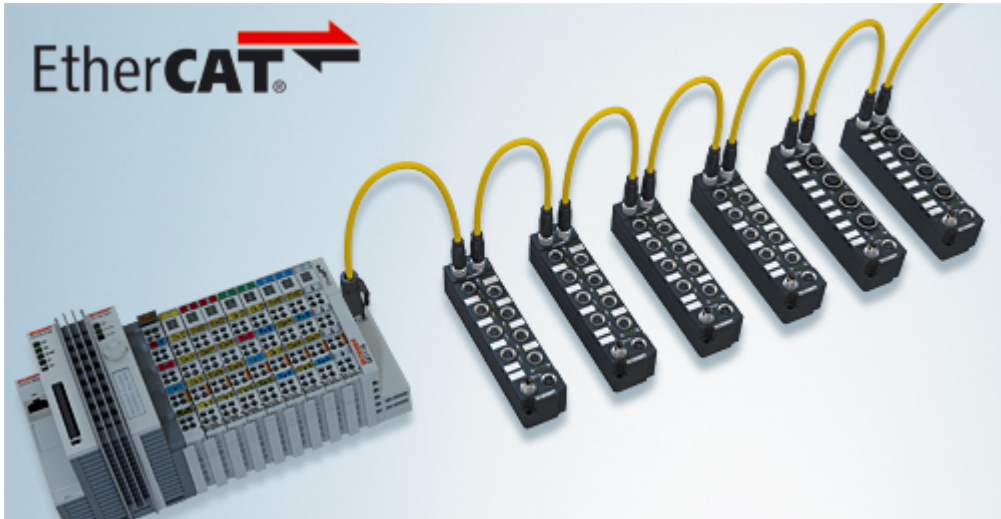

Fig. 1: EtherCAT Box Modules within an EtherCAT network

The robust design of the EtherCAT Box modules enables them to be used directly at the machine. Control cabinets and terminal boxes are now no longer required. The modules are fully sealed and therefore ideally prepared for wet, dirty or dusty conditions.

Pre-assembled cables significantly simplify EtherCAT and signal wiring. Very few wiring errors are made, so that commissioning is optimized. In addition to pre-assembled EtherCAT, power and sensor cables, field-configurable connectors and cables are available for maximum flexibility. Depending on the application, the sensors and actuators are connected through M8 or M12 connectors.

The EtherCAT modules cover the typical range of requirements for I/O signals with protection class IP67:

- digital inputs with different filters (3.0 ms or 10 μ s)
- digital outputs with 0.5 or 2 A output current
- analog inputs and outputs with 16 bit resolution
- Thermocouple and RTD inputs
- Stepper motor modules

XFC (eXtreme Fast Control Technology) modules, including inputs with time stamp, are also available.



Fig. 2: EtherCAT Box with M8 connections for sensors/actuators



Fig. 3: EtherCAT Box with M12 connections for sensors/actuators

● Basic EtherCAT documentation

i You will find a detailed description of the EtherCAT system in the Basic System Documentation for EtherCAT, which is available for download from our website (www.beckhoff.com) under Downloads.

3 Product overview

The following table shows the products described in this documentation and the main distinguishing features.

Module	Signal connection	Number of outputs	Output current		Number of inputs	Input filter
			per output	Sum		
EP2308-0001 [▶ 13]	8 x M8	4	0.5 A	4 A	4	3.0 ms
EP2308-0002 [▶ 13]	4 x M12	4	0.5 A	4 A	4	3.0 ms
EP2316-0003 [▶ 21]	2 x ZS2001	8	0.5 A	4 A	8	10 µs
EP2316-0008 [▶ 22]	1 x D-sub 25	8	0.5 A	4 A	8	10 µs
EP2318-0001 [▶ 13]	8 x M8	4	0.5 A	4 A	4	10 µs
EP2318-0002 [▶ 13]	4 x M12	4	0.5 A	4 A	4	10 µs
EP2328-0001 [▶ 13]	4 x M8	4	2.0 A	4 A	4	3.0 ms
EP2328-0002 [▶ 13]	4 x M12	4	2.0 A	4 A	4	3.0 ms
EP2338-0001 [▶ 29]	8 x M8	0 to 8	0.5 A	4 A	8 to 0	10 µs
EP2338-0002 [▶ 29]	4 x M12	0 to 8	0.5 A	4 A	8 to 0	10 µs
EP2338-1001 [▶ 29]	8 x M8	0 to 8	0.5 A	4 A	8 to 0	3.0 ms
EP2338-1002 [▶ 29]	4 x M12	0 to 8	0.5 A	4 A	8 to 0	3.0 ms
EP2338-2002 [▶ 35]	4 x M12	0 to 8	0.5 A	4 A	8 to 0	10 µs
EP2339-0003 [▶ 40]	2 x ZS2001	0 to 16	0.5 A	4 A	16 to 0	3.0 ms
EP2339-0021 [▶ 46]	16 x M8	0 to 16	0.5 A	4 A	16 to 0	3.0 ms
EP2339-0022 [▶ 47]	8 x M12	0 to 16	0.5 A	4 A	16 to 0	3.0 ms
EP2339-0042 [▶ 52]	8 x M12	0 to 16	0.5 A	16 A	16 to 0	3.0 ms
EP2339-0121 [▶ 58]	16 x M8	0 to 16 ¹⁾	0.5 A	4 A	16 to 0 ¹⁾	3.0 ms
EP2349-0021 [▶ 46]	16 x M8	0 to 16	0.5 A	4 A	16 to 0	10 µs
EP2349-0022 [▶ 47]	8 x M12	0 to 16	0.5 A	4 A	16 to 0	10 µs

¹⁾ The inputs and outputs of the EP2339-0121 are ground switching.

3.1 EP2308, EP2318, EP2328

3.1.1 EP2308, EP2318, EP2328 - Introduction

EP23x8-0001

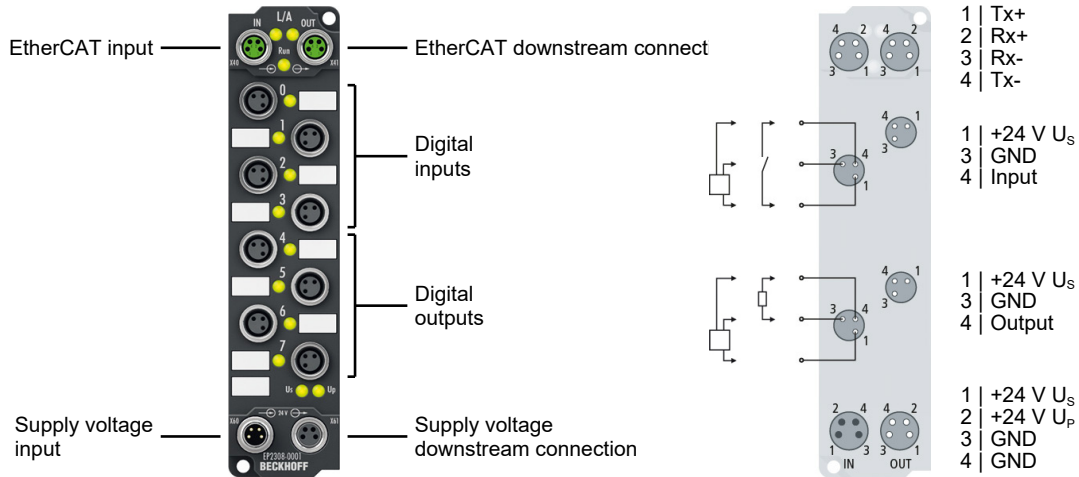

EP23x8-0002

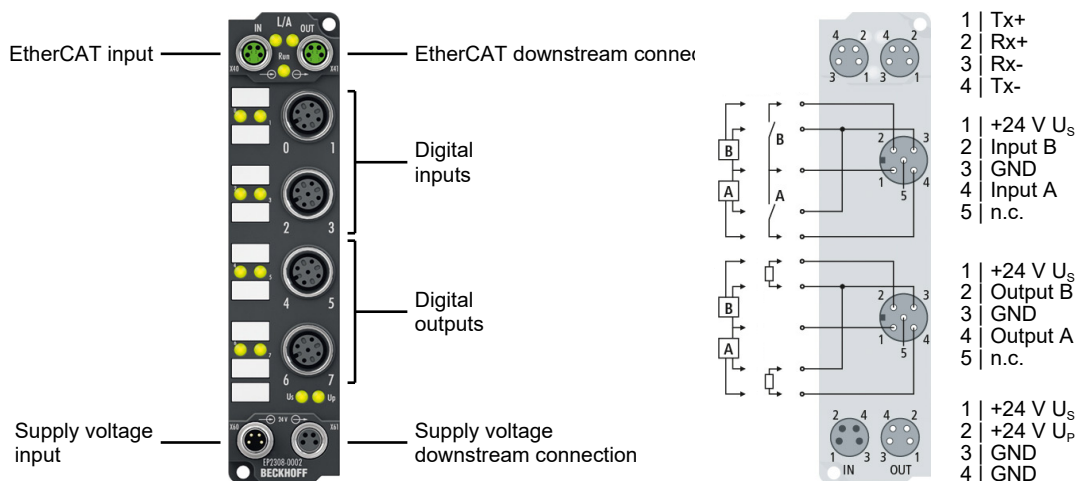

4 digital inputs 24 VDC and 4 digital outputs 24 V_{DC}, I_{max} 0.5 A oder 2 A

The EP2308, EP2318 and EP2328 EtherCAT-Box modules combine four digital inputs and four digital outputs in one device.

The state of each signal is indicated by means of light emitting diodes. The signals are optionally connected via M8 connectors (EP23x8-0001) or M12 connectors (EP23x8-0002).

Various filter constants are available for the inputs. The outputs process load currents up to 0.5 A (EP2308, EP2318) or 2 A (EP2328) and are short-circuit proof and protected against inverse polarity.

Quick links

[Technical data EP2308](#) [▶ 15]

[Technical data EP2318](#) [▶ 15]

[Technical data EP2328](#) [▶ 17]

[Process image](#) [▶ 20]

[EPxxxx-x001 dimensions](#) [▶ 62]

[EPxxx-x002 dimensions \[▶ 63\]](#)

[Signal interface M8 \[▶ 78\]](#) (EP2308-0001, EP2318-0001, EP2328-0001)

[Signal interface M12 \[▶ 79\]](#) (EP2308-0002, EP2318-0002, EP2328-0002)

3.1.2 EP2308, EP2318 - Technical Data

All values are typical values over the entire temperature range, unless stated otherwise.

EtherCAT	
Connection	2 x M8 socket, 4-pin, A-coded, shielded
Electrical isolation	500 V

Supply voltages	
Connection	Input: M8 connector, 4-pin, A-coded Downstream connection: M8 socket, 4-pin, A-coded
U_S nominal voltage	24 V _{DC} (-15 % / +20 %)
U_S sum current: $I_{S,sum}$	max. 4 A
Current consumption from U_S	120 mA + sensor supply
Rated voltage U_P	24 V _{DC} (-15 % / +20 %)
U_P sum current: $I_{P,sum}$	max. 4 A
Current consumption from U_P	20 mA + Loads at digital outputs
Electrical isolation GND_S / GND_P	no

Digital inputs	EP2308-0001	EP2308-0002	EP2318-0001	EP2318-0002
Number	4			
Connection	4 x M8 socket	2 x M12 socket	4 x M8 socket	2 x M12 socket
Cable length	max. 30 m			
Input filter	3.0 ms	3.0 ms	10 μs	10 μs
Characteristics	Type 3 according to EN61131-2, compatible with type 1			
Signal voltage "0"	-3...+5 V			
Signal voltage "1"	+11...+30 V			
Input current	6 mA			
Sensor power supply	24 V _{DC} from U_S . max. 0.5 A in total, short-circuit proof.			

Digital outputs	EP2308-0001	EP2308-0002	EP2318-0001	EP2318-0002
Number	4			
Connection	4 x M8 socket	2 x M12 socket	4 x M8 socket	2 x M12 socket
Cable length	max. 30 m			
Load type	Ohmic, inductive, lamp load			
Nominal output voltage	24 V _{DC}			
Output current per channel	max. 0.5 A. Each output is independently short-circuit proof.			
Output sum current	max. 4 A			
Short circuit current	max. 1.5 A			
Output driver supply	From the peripheral voltage U_P .			
Changeover times	T_{ON} : 50 μs typ., T_{OFF} : 100 μs typ.			

Housing data	
Dimensions W x H x D	30 mm x 126 mm x 26.5 mm (without connectors)
Weight	approx. 165 g
Installation position	variable
Material	PA6 (polyamide)

Environmental conditions	
Ambient temperature during operation	-25 ... +60 °C -25 ... +55 °C according to cURus 0 ... +55 °C according to ATEX
Ambient temperature during storage	-40 ... +85 °C
Vibration resistance, shock resistance	conforms to EN 60068-2-6 / EN 60068-2-27 Additional tests [▶ 16]
EMC immunity / emission	conforms to EN 61000-6-2 / EN 61000-6-4
Protection rating	IP65, IP66, IP67 (according to EN 60529)

Approvals / markings	
Approvals / markings *)	ATEX [▶ 91], CE, cURus [▶ 90]

*) Real applicable approvals/markings see type plate on the side (product marking).

Additional tests

The devices have undergone the following additional tests:

Test	Explanation
Vibration	10 frequency sweeps in 3 axes
	5 Hz < f < 60 Hz displacement 0.35 mm, constant amplitude
	60.1 Hz < f < 500 Hz acceleration 5 g, constant amplitude
Shocks	1000 shocks in each direction, in 3 axes
	35 g, 11 ms

3.1.3 EP2328 – Technical data

All values are typical values over the entire temperature range, unless stated otherwise.

EtherCAT	
Connection	2 x M8 socket, 4-pin, A-coded, shielded
Electrical isolation	500 V

Supply voltages	
Connection	Input: M8 connector, 4-pin, A-coded Downstream connection: M8 socket, 4-pin, A-coded
U_S nominal voltage	24 V _{DC} (-15 % / +20 %)
U_S sum current: $I_{S,sum}$	max. 4 A
Current consumption from U_S	120 mA + sensor supply
Rated voltage U_P	24 V _{DC} (-15 % / +20 %)
U_P sum current: $I_{P,sum}$	max. 4 A
Current consumption from U_P	20 mA + Loads at digital outputs
Electrical isolation GND_S / GND_P	no

Digital inputs	EP2328-0001	EP2328-0002
Number	4	
Connection	4 x M8 socket	2 x M12 socket
Cable length	max. 30 m	
Input filter	3.0 ms	
Characteristics	Type 3 according to EN61131-2, compatible with type 1	
Signal voltage "0"	-3...+5 V	
Signal voltage "1"	+11...+30 V	
Input current	6 mA	
Sensor power supply	24 V _{DC} from U_S . max. 0.5 A in total, short-circuit proof.	

Digital outputs	EP2328-0001	EP2328-0002
Number	4	
Connection	4 x M8 socket	2 x M12 socket
Cable length	max. 30 m	
Load type	Ohmic, inductive, lamp load	
Nominal output voltage	24 V _{DC}	
Output current per channel	max. 2 A. Each output is independently short-circuit proof.	
Output sum current	max. 4 A	
Short circuit current	15 A typ.	
Changeover times	T_{ON} : 200 μ s typ., T_{OFF} : 200 μ s typ.	
Output driver supply	From the peripheral voltage U_P .	

Housing data	
Dimensions W x H x D	30 mm x 126 mm x 26.5 mm (without connectors)
Weight	approx. 165 g
Installation position	variable
Material	PA6 (polyamide)

Environmental conditions	
Ambient temperature during operation	-25 ... +60 °C -25 ... +55 °C according to cURus 0 ... +55 °C according to ATEX
Ambient temperature during storage	-40 ... +85 °C
Vibration resistance, shock resistance	conforms to EN 60068-2-6 / EN 60068-2-27 Additional tests [► 18]
EMC immunity / emission	conforms to EN 61000-6-2 / EN 61000-6-4
Protection rating	IP65, IP66, IP67 (according to EN 60529)

Approvals / markings	
Approvals / markings *)	ATEX [► 91], CE, cURus [► 90]

*) Real applicable approvals/markings see type plate on the side (product marking).

Additional tests

The devices have undergone the following additional tests:

Test	Explanation
Vibration	10 frequency sweeps in 3 axes
	5 Hz < f < 60 Hz displacement 0.35 mm, constant amplitude
	60.1 Hz < f < 500 Hz acceleration 5 g, constant amplitude
Shocks	1000 shocks in each direction, in 3 axes
	35 g, 11 ms

3.1.4 EP2308, EP2318, EP2328 - Scope of supply

Make sure that the following components are included in the scope of delivery:

- 1x EtherCAT Box EP23x8-000x
- 2x protective cap for EtherCAT socket, M8, green (pre-assembled)
- 1x protective cap for supply voltage input, M8, transparent (pre-assembled)
- 1x protective cap for supply voltage output, M8, black (pre-assembled)
- 10x labels, blank (1 strip of 10)

● Pre-assembled protective caps do not ensure IP67 protection

i Protective caps are pre-assembled at the factory to protect connectors during transport. They may not be tight enough to ensure IP67 protection.

Ensure that the protective caps are correctly seated to ensure IP67 protection.

3.1.5 EP2308, EP2318, EP2328 - Process image

DI Inputs

Under **Channel 1** to **Channel 4** you will find the 4 digital inputs of the module (in the example the EP2308-0001).

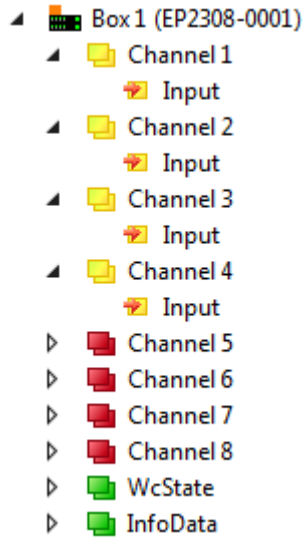

Data types

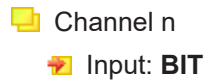

DO Outputs

Under **Channel 5** to **Channel 8** you will find the 4 digital outputs of the module (in the example the EP2308-0001).

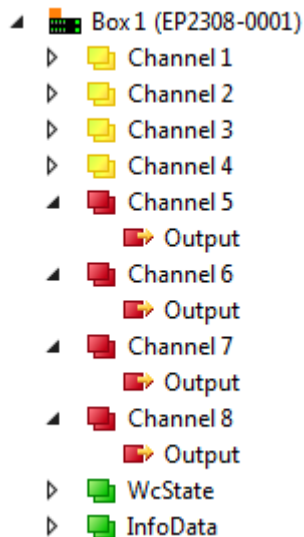

Data types



3.2 EP2316-0003, EP2316-0008

3.2.1 EP2316-0003 - Introduction

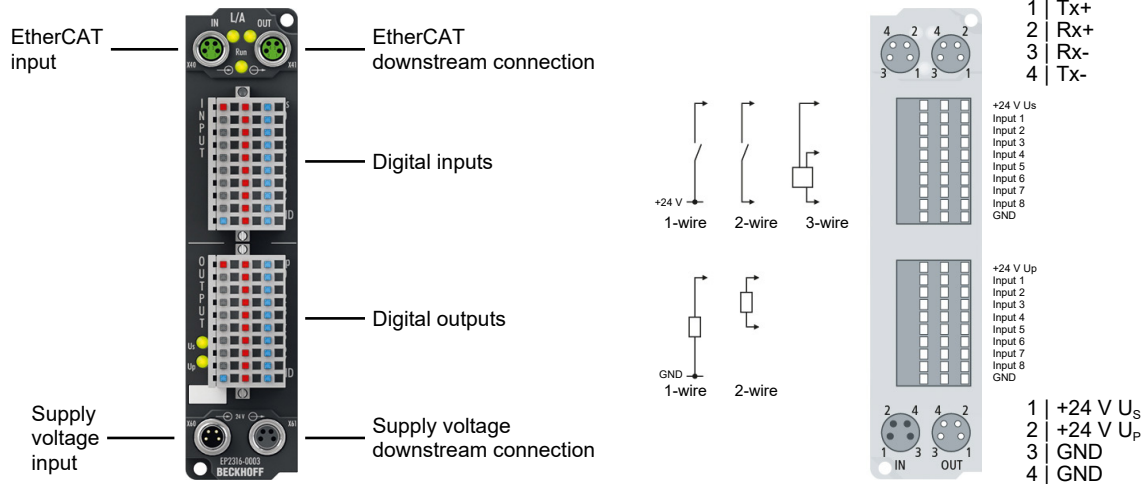

8 digital inputs 24 V_{DC}, 8 digital outputs 24 V_{DC}, I_{max} 0.5 A

The EP2316 EtherCAT Box combines eight digital inputs and eight digital outputs in one device. The inputs are available with a 10 μs filter constant.

The outputs process load currents up to 0.5 A, are short-circuit proof and protected against inverse polarity. Signal state and status are indicated by LEDs.

The signal connection is made via two ZS2001 connectors with spring-loaded system, optionally available with 1 or 3 pins. The module is delivered without connectors.

Quick links

- [Technical data \[▶ 23\]](#)
- [Process image \[▶ 26\]](#)
- [Dimensions \[▶ 64\]](#)
- [Signal interface \[▶ 80\]](#)

3.2.2 EP2316-0008 - Introduction

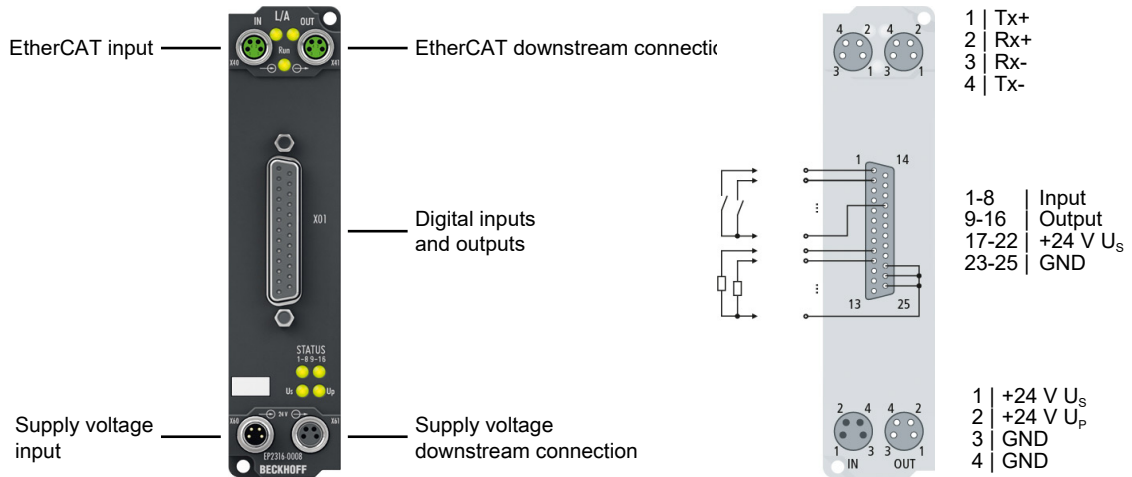

8 digital inputs, 24 V_{DC}, 8 digital outputs, 24 V_{DC}, I_{max} 0.5 A

The EP2316 EtherCAT Box combines eight digital inputs and eight digital outputs in one device. The inputs are available with a 10 μs filter constant.

The outputs process load currents up to 0.5 A, are short-circuit proof and protected against inverse polarity.

The signal connection is made through a 25-pin D-Sub socket.

The signal state and the status are displayed in groups by light emitting diodes.

Quick links

[Technical data \[▶ 23\]](#)

[Process image \[▶ 26\]](#)

[Dimensions \[▶ 65\]](#)

[Signal interface \[▶ 81\]](#)

3.2.3 EP2316-000x - Technical Data

All values are typical values over the entire temperature range, unless stated otherwise.

EtherCAT	
Connection	2 x M8 socket, 4-pin, A-coded, shielded
Electrical isolation	500 V

Supply voltages	
Connection	Input: M8 connector, 4-pin, A-coded Downstream connection: M8 socket, 4-pin, A-coded
U_S nominal voltage	24 V _{DC} (-15 % / +20 %)
U_S sum current: $I_{S,sum}$	max. 4 A
Current consumption from U_S	120 mA + sensor supply
Rated voltage U_P	24 V _{DC} (-15 % / +20 %)
U_P sum current: $I_{P,sum}$	max. 4 A
Current consumption from U_P	20 mA + Loads at digital outputs
Electrical isolation GND_S / GND_P	no

Digital inputs	EP2316-0003	EP2316-0008
Number	8	
Connection	1 x ZS2001 connector	1 x D-sub socket, 25-pin, thread UNC4-40 Pin 1...8
Cable length	max. 30 m	
Input filter	10 μ s	
Characteristics	Type 3 according to EN61131-2, compatible with type 1	
Signal voltage "0"	-3...+5 V	
Signal voltage "1"	+11...+30 V	
Input current	6 mA	
Sensor power supply	24 V _{DC} from U_S . max. 0.5 A in total, short-circuit proof.	

Digital outputs	EP2316-0003	EP2316-0008
Number	8	
Connection	1 x ZS2001 connector	1 x D-sub socket, 25-pin, thread UNC4-40 Pin 9...16
Cable length	max. 30 m	
Load type	Ohmic, inductive, lamp load	
Nominal output voltage	24 V _{DC} from U_P	
Output current per channel	max. 0.5 A. Each output is independently short-circuit proof.	
Output sum current	max. 4 A	
Short circuit current	max. 1.5 A	
Output driver supply	from U_P	
Changeover times	T_{ON} : 25 μ s typ., T_{OFF} : 50 μ s typ.	T_{ON} : 60 μ s typ., T_{OFF} : 300 μ s typ.

Housing data	
Dimensions W x H x D	30 mm x 126 mm x 26.5 mm (without connectors)
Weight	approx. 165 g
Installation position	variable
Material	PA6 (polyamide)

Environmental conditions	
Ambient temperature during operation	-25 ... +60 °C -25 ... +55 °C according to cURus
Ambient temperature during storage	-40 ... +85 °C
Vibration resistance, shock resistance	conforms to EN 60068-2-6 / EN 60068-2-27 Additional tests [► 16]
EMC immunity / emission	conforms to EN 61000-6-2 / EN 61000-6-4
Protection class	IP65, IP66, IP67 (conforms to EN 60529)

Approvals/markings	
Approvals/markings *)	CE, cURus [► 90]

*) Real applicable approvals/markings see type plate on the side (product marking).

3.2.4 EP2316-000x - Scope of supply

Make sure that the following components are included in the scope of delivery:

- 1x EtherCAT Box EP2316-000x
- 2x protective cap for EtherCAT socket, M8, green (pre-assembled)
- 1x protective cap for supply voltage input, M8, transparent (pre-assembled)
- 1x protective cap for supply voltage output, M8, black (pre-assembled)
- 10x labels, blank (1 strip of 10)

● Pre-assembled protective caps do not ensure IP67 protection

i Protective caps are pre-assembled at the factory to protect connectors during transport. They may not be tight enough to ensure IP67 protection.

Ensure that the protective caps are correctly seated to ensure IP67 protection.

3.2.5 EP2316-0008 - Status LEDs



Fig. 4: EP2316-0008 - Status LEDs

LED displays

LED	Display	Meaning
STATUS 1-8	green illuminated	a signal (24 V) is present at a least one input of channels 1-8
STATUS 9-16	green illuminated	at least one of the outputs for channel 9-16 is set
	red illuminated	at least one output of channels 9-16 has an error
Us	off	Supply voltage Us is not present
	green illuminated	Supply voltage Us is present
Up	off	Supply voltage Up is not present
	green illuminated	Supply voltage Up is present



3.2.6 EP2316-000x - Process image

DIG Inputs

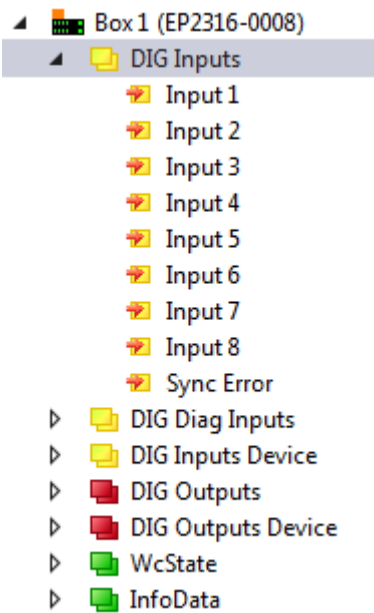
You will find the 8 digital inputs of the module under **DIG Inputs**.



Data types



-  DIG Inputs
 -  Input n: **BIT**
 -  Sync Error: **BIT**

DIG Diag Inputs

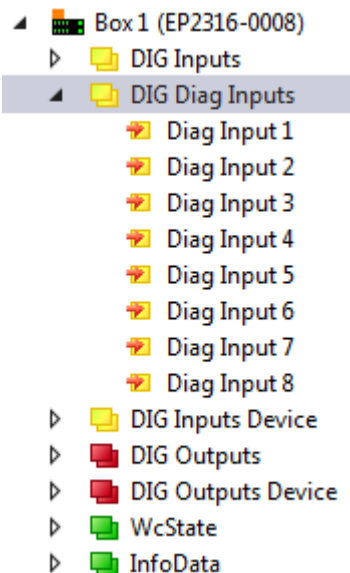
You will find the diagnostic inputs for the module's 8 digital outputs under **DIG Diag Inputs**.



Data types

-  DIG Diag Inputs
 -  Diag Input n: **BIT**

Diag Input n





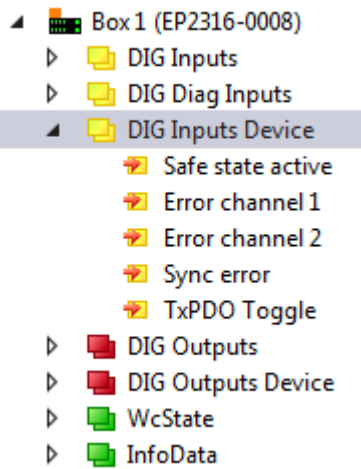

Indicates an error on Output n.

DIG Inputs Device

You will find the module's status inputs under **DIG Inputs Device**.



Data types

-  DIG Inputs Device
 -  Safe state active: **BIT**
 -  Error channel 1: **BIT**
 -  Error channel 2: **BIT**
 -  Sync error: **BIT**
 -  TxPDO Toggle: **BIT**

Safe state active

Indicates whether the safe state has been assumed. The display only works if the network transmits process input data, i.e. in the network states Operational (OP) and Safe-Operational (Safe-OP), but not in the network state INIT.

Error channel 1

This bit is always 0.

Error channel 2

Group error for all eight channels.

Sync Error

See EtherCAT system documentation. The EtherCAT system documentation is available on www.beckhoff.com.

TxPDO Toggle

See EtherCAT system documentation.

DIG Outputs

You will find the 8 digital outputs of the module under **DIG Outputs**.

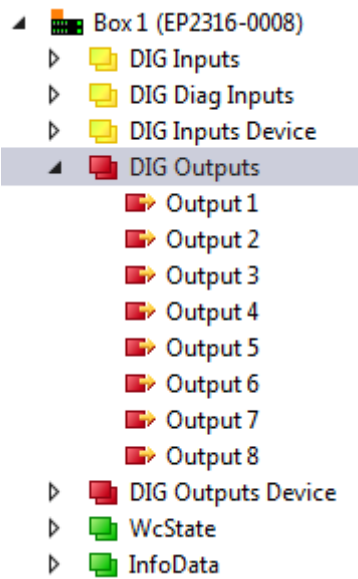

Data types

- ▶ DIG Outputs
 - ▶ Output n: **BIT**

DIG Outputs Device

You will find the module's control outputs under **DIG Outputs Device**.

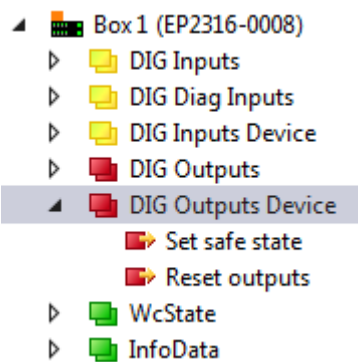

Data types

- ▶ DIG Outputs Device
 - ▶ Set safe state: **BIT**
 - ▶ Reset outputs: **BIT**

Set safe state

Sets the module to the safe state.

Reset outputs

Resets the error bits "Error channel X" of the module. The outputs are reactivated.

3.3 EP2338-000x, EP2338-100x

3.3.1 EP2338-000x, EP2338-100x - Introduction

EP2338-x001

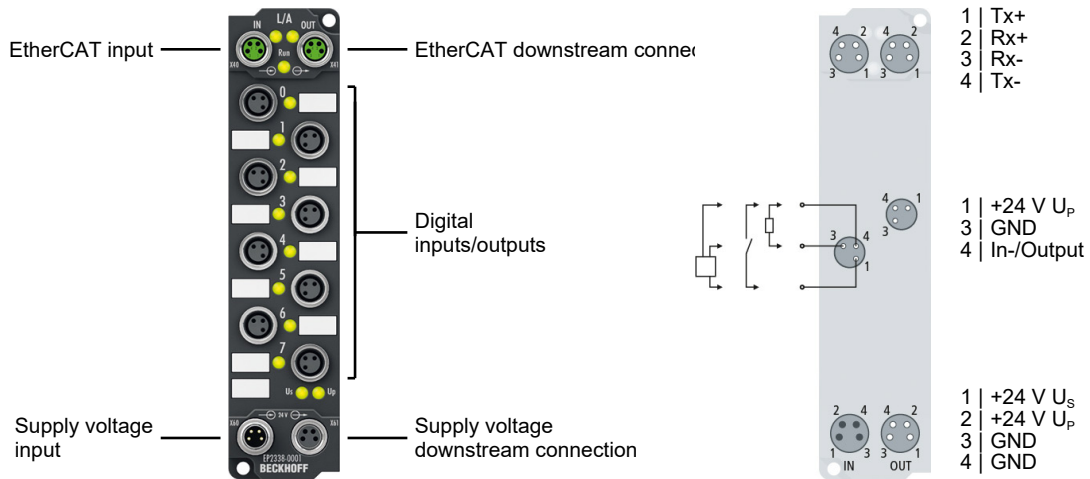

EP2338-x002

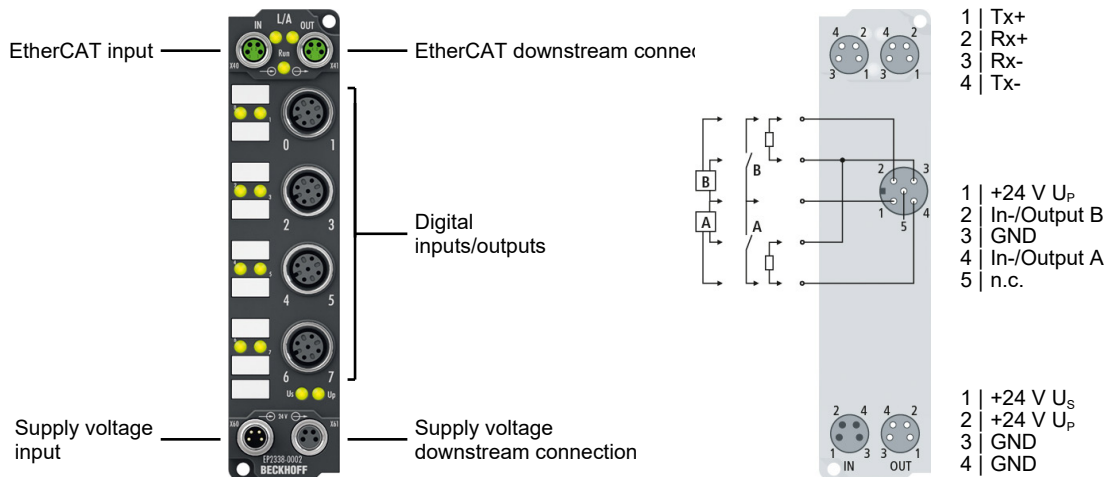

8 digital inputs or outputs, 24 V_{DC}

The EP2338 EtherCAT Box has eight digital channels, each of which can be operated either as inputs or outputs. A configuration whether a channel is to be used as input or output is not required; the input circuit is internally permanently connected to the output driver so that a set output is automatically displayed in the input process image.

The outputs process load currents up to 0.5 A, are short-circuit proof and protected against polarity reversal. The inputs have a filter constant of 10 μs (EP2338-0001, EP2338-0002) or 3 ms (EP2338-1001, EP2338-1002). The state of each signal is indicated by means of LEDs. The signals are connected either via M8 (EP2338-x001) or M12 connectors (EP2338-x002).

i Supply of the connected sensors from U_P, not from U_S

Unlike many other modules, the EP2338-xxxx supply connected sensors from the peripheral voltage U_P instead of the control voltage U_S. Nevertheless, an overload of the sensor supply (current > 0.5 A) is indicated by the LED U_S lighting up red.

Exception: The EP2338-2002 supplies connected sensors from U_S. See chapter EP2338-2002 [▶ 35].

NOTICE**For shutdown in the event of a fault, do not supply sensors externally**

If the design of your installation is such that the supply voltage U_p is switched off in the event of a fault, you must not power the connected sensors externally, but only through the EP2338! Otherwise, when the U_p energy is switched off, the EP2338 can continue to draw energy from the external sensor power supply, and the outputs will not be switched off.

Quick links

[Technical data \[▶ 31\]](#)

[Process image \[▶ 33\]](#)

[EPxxx-x001 dimensions \[▶ 62\]](#)

[EPxxx-x002 dimensions \[▶ 63\]](#)

[Signal interface M8 \[▶ 82\]](#) (EP2338-0001, EP2338-1001)

[Signal interface M12 \[▶ 83\]](#) (EP2338-0002, EP2338-1002)

3.3.2 EP2338-000x, EP2338-100x - Technical data

All values are typical values over the entire temperature range, unless stated otherwise.

EtherCAT	
Connection	2 x M8 socket, 4-pin, A-coded, shielded
Electrical isolation	500 V

Supply voltages	
Connection	Input: M8 connector, 4-pin, A-coded Downstream connection: M8 socket, 4-pin, A-coded
U_S nominal voltage	24 V _{DC} (-15 % / +20 %)
Current consumption from U_S	120 mA
U_S sum current: $I_{S,sum}$	max. 4 A
Rated voltage U_P	24 V _{DC} (-15 % / +20 %)
Current consumption from U_P	20 mA + Loads at digital outputs + sensor supply
U_P sum current: $I_{P,sum}$	max. 4 A
Electrical isolation GND _S / GND _P	no

Digital inputs	EP2338-0001	EP2338-1001	EP2338-0002	EP2338-1002
Number	0 to 8 Each digital input can alternatively be used as a digital output.			
Connection	8 x M8 socket		4 x M12 socket	
Cable length	max. 30 m			
Input filter	10 μs	3.0 ms	10 μs	3.0 ms
Characteristics	Type 3 according to EN61131-2, compatible with type 1			
Signal voltage "0"	-3...+5 V			
Signal voltage "1"	+11...+30 V			
Input current	6 mA			
Sensor power supply	24 V _{DC} from U_P . max. 0.5 A in total, short-circuit proof.			

Digital outputs	EP2338-0001	EP2338-1001	EP2338-0002	EP2318-1002
Number	0 to 8 Each digital output can alternatively be used as a digital input.			
Connection	8 x M8 socket		4 x M12 socket	
Cable length	max. 30 m			
Load type	Ohmic, inductive, lamp load			
Nominal output voltage	24 V _{DC}			
Output current per channel	max. 0.5 A. Each output is independently short-circuit proof.			
Output sum current	max. 4 A			
Short circuit current	max. 1.5 A			
Changeover times	T_{ON} : 50 μs typ., T_{OFF} : 100 μs typ.			
Output driver supply	From the peripheral voltage U_P .			

Housing data	
Dimensions W x H x D	30 mm x 126 mm x 26.5 mm (without connectors)
Weight	approx. 165 g
Installation position	variable
Material	PA6 (polyamide)

Environmental conditions	
Ambient temperature during operation	-25 ... +60 °C -25 ... +55 °C according to cURus 0 ... +55 °C according to ATEX
Ambient temperature during storage	-40 ... +85 °C
Vibration resistance, shock resistance	conforms to EN 60068-2-6 / EN 60068-2-27 Additional tests [► 32]
EMC immunity / emission	conforms to EN 61000-6-2 / EN 61000-6-4
Protection rating	IP65, IP66, IP67 (according to EN 60529)

Approvals / markings	
Approvals / markings *)	ATEX [► 91], CE, cURus [► 90]

*) Real applicable approvals/markings see type plate on the side (product marking).

Additional tests

The devices have undergone the following additional tests:

Test	Explanation
Vibration	10 frequency sweeps in 3 axes
	5 Hz < f < 60 Hz displacement 0.35 mm, constant amplitude
	60.1 Hz < f < 500 Hz acceleration 5 g, constant amplitude
Shocks	1000 shocks in each direction, in 3 axes
	35 g, 11 ms

3.3.3 EP2338-x00x - Scope of supply

Make sure that the following components are included in the scope of delivery:

- 1x EtherCAT Box EP2338-x00x
- 2x protective cap for EtherCAT socket, M8, green (pre-assembled)
- 1x protective cap for supply voltage input, M8, transparent (pre-assembled)
- 1x protective cap for supply voltage output, M8, black (pre-assembled)
- 10x labels, blank (1 strip of 10)



Pre-assembled protective caps do not ensure IP67 protection



























Protective caps are pre-assembled at the factory to protect connectors during transport. They may not be tight enough to ensure IP67 protection.

Ensure that the protective caps are correctly seated to ensure IP67 protection.



3.3.4 EP2338-x00x - Process image

DI Inputs

Under **Channel 1** to **Channel 8** you will find the 8 digital inputs of the module (in the example the EP2338-0001).

- ▲  Box 1 (EP2338-0001)
 - ▲  Channel 1
 - ▶  Input
 - ▲  Channel 2
 - ▶  Input
 - ▲  Channel 3
 - ▶  Input
 - ▲  Channel 4
 - ▶  Input
 - ▲  Channel 5
 - ▶  Input
 - ▲  Channel 6
 - ▶  Input
 - ▲  Channel 7
 - ▶  Input
 - ▲  Channel 8
 - ▶  Input
 - ▶  Channel 9
 - ▶  Channel 10
 - ▶  Channel 11
 - ▶  Channel 12
 - ▶  Channel 13
 - ▶  Channel 14
 - ▶  Channel 15
 - ▶  Channel 16
 - ▶  WcState
 - ▶  InfoData

Data types

-  Channel n
 - ▶  Input: **BIT**

DO Outputs

Under **Channel 1** to **Channel 8** you will find the 8 digital outputs of the module (in the example the EP2338-0001).

- └─ Box 1 (EP2338-0001)
 - └─ Channel 1
 - └─ Channel 2
 - └─ Channel 3
 - └─ Channel 4
 - └─ Channel 5
 - └─ Channel 6
 - └─ Channel 7
 - └─ Channel 8
 - └─ Channel 9
 - └─ Output
 - └─ Channel 10
 - └─ Output
 - └─ Channel 11
 - └─ Output
 - └─ Channel 12
 - └─ Output
 - └─ Channel 13
 - └─ Output
 - └─ Channel 14
 - └─ Output
 - └─ Channel 15
 - └─ Output
 - └─ Channel 16
 - └─ Output
 - └─ WcState
 - └─ InfoData

Data types

- └─ Channel n
 - └─ Output: **BIT**

3.4 EP2338-2002

3.4.1 EP2338-2002 - Introduction

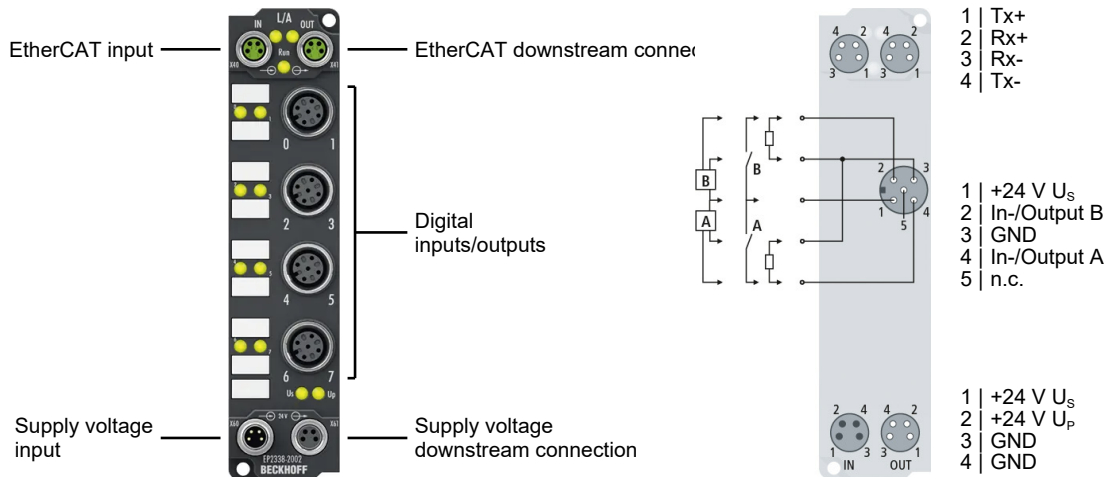

The EP2338-2002 EtherCAT Box has eight digital channels, each of which can be operated either as inputs or outputs. It is not necessary to configure whether a channel (pin 2 and pin 4 of the M12 sockets) is to be used as input or output. The input circuit is permanently connected to the output driver internally so that a set output is also automatically displayed in the input process image.

The inputs have a 10 μs filter. The outputs process load currents up to 0.5 A, are short-circuit proof and protected against polarity reversal. The sum current of all outputs is limited to 4 A. The connected sensors are supplied via U_S. The current is limited to 4 A. The signal state is displayed by LEDs; the signal connection is established via screw-type M12 connectors.

● Sensor power supply from U_S

i In contrast to other EP2338-xxxx, the EP2338-2002 supplies connected sensors from the control voltage U_S. All other EP2338-xxxx supply connected sensors from the peripheral voltage U_P. See chapter [EP2338-000x, EP2338-100x](#) [▶ 29].

Quick links

- [Technical data](#) [▶ 36]
- [Process image](#) [▶ 38]
- [Dimensions](#) [▶ 63]
- [Signal interface](#) [▶ 84]

3.4.2 EP2338-2002 - Technical data

All values are typical values over the entire temperature range, unless stated otherwise.

EtherCAT	
Connection	2 x M8 socket, 4-pin, A-coded, shielded
Electrical isolation	500 V

Supply voltages	
Connection	Input: M8 connector, 4-pin, A-coded Downstream connection: M8 socket, 4-pin, A-coded
U_S nominal voltage	24 V _{DC} (-15 % / +20 %)
Current consumption from U_S	120 mA + sensor power supply
U_S sum current: $I_{S,sum}$	max. 4 A
Rated voltage U_P	24 V _{DC} (-15 % / +20 %)
Current consumption from U_P	20 mA + load
U_P sum current: $I_{P,sum}$	max. 4 A
Electrical isolation GND _S / GND _P	no

Digital inputs	
Number	0 to 8 Each digital input can alternatively be used as a digital output.
Connection	4 x M12 socket
Cable length	max. 30 m
Input filter	10 μs
Characteristics	Type 3 according to EN61131-2, compatible with type 1
Signal voltage "0"	-3...+5 V
Signal voltage "1"	+11...+30 V
Input current	6 mA
Sensor power supply	24 V _{DC} from U_S . max. 1.4 A in total, short-circuit proof.

Digital outputs	
Number	0 to 8 Each digital output can alternatively be used as a digital input.
Connection	4 x M12 socket
Cable length	max. 30 m
Load type	Ohmic, inductive, lamp load
Nominal output voltage	24 V _{DC} from U_P .
Output current per channel	max. 0.5 A. Each output is independently short-circuit proof.
Output sum current	max. 4 A
Short-circuit current	max. 1.5 A
Changeover times	T_{ON} : 50 μs typ., T_{OFF} : 100 μs typ.
Output driver supply	From the peripheral voltage U_P .

Housing data	
Dimensions W x H x D	30 mm x 126 mm x 26.5 mm (without connectors)
Weight	approx. 165 g
Installation position	variable
Material	PA6 (polyamide)

Environmental conditions	
Ambient temperature during operation	-25 ... +60 °C -25 ... +55 °C according to cURus
Ambient temperature during storage	-40 ... +85 °C
Vibration resistance, shock resistance	conforms to EN 60068-2-6 / EN 60068-2-27 Additional tests [► 37]
EMC immunity / emission	conforms to EN 61000-6-2 / EN 61000-6-4
Protection class	IP65, IP66, IP67 (conforms to EN 60529)

Approvals/markings	
Approvals/markings *)	CE, cURus [► 90]

*) Real applicable approvals/markings see type plate on the side (product marking).

Additional tests

The devices have undergone the following additional tests:

Test	Explanation
Vibration	10 frequency sweeps in 3 axes
	5 Hz < f < 60 Hz displacement 0.35 mm, constant amplitude
	60.1 Hz < f < 500 Hz acceleration 5 g, constant amplitude
Shocks	1000 shocks in each direction, in 3 axes
	35 g, 11 ms

3.4.3 EP2338-2002 - Scope of supply

Make sure that the following components are included in the scope of delivery:

- 1x EP2338-2002 EtherCAT Box
- 1x protective cap for supply voltage input, M8, transparent (pre-assembled)
- 1x protective cap for supply voltage output, M8, black (pre-assembled)
- 2x protective cap for EtherCAT socket, M8, green (pre-assembled)
- 10x labels, blank (1 strip of 10)

● Pre-assembled protective caps do not ensure IP67 protection

i Protective caps are pre-assembled at the factory to protect connectors during transport. They may not be tight enough to ensure IP67 protection.

Ensure that the protective caps are correctly seated to ensure IP67 protection.

3.4.4 EP2338-2002 - Process image





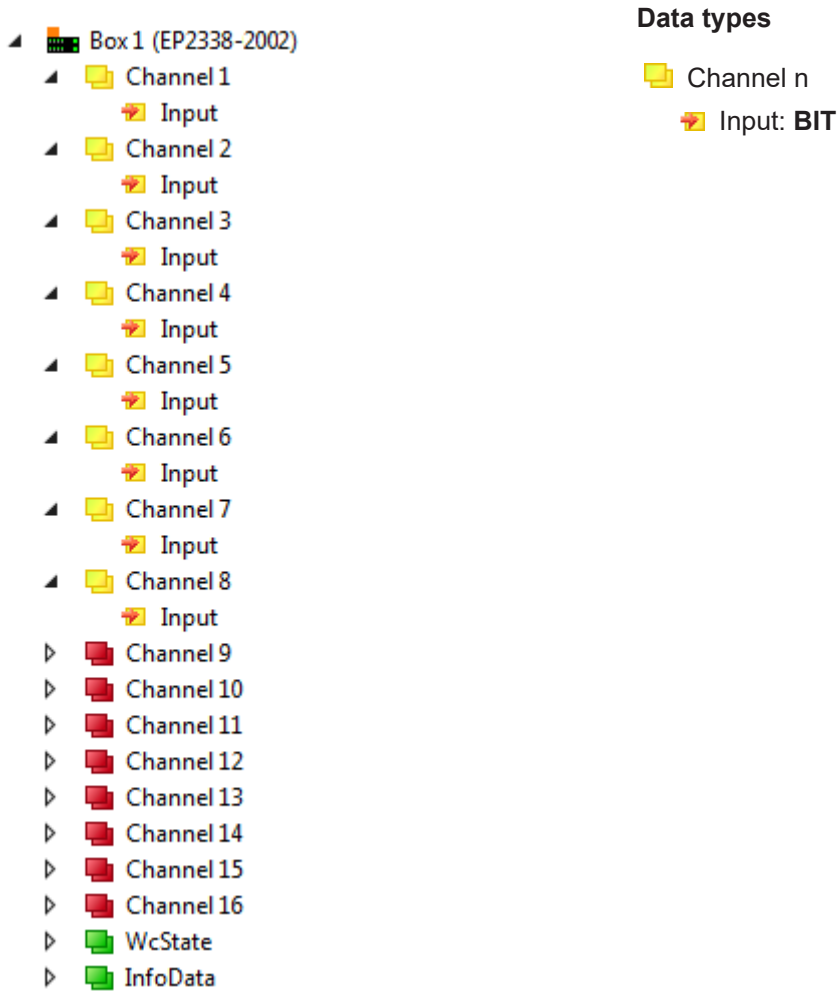





















DI Inputs

You can find the digital inputs at "Channel 1" to "Channel 8".





DO Outputs

You can find the digital outputs at "Channel 1" to "Channel 8".

- ▶  Channel 1
 - ▶  Channel 2
 - ▶  Channel 3
 - ▶  Channel 4
 - ▶  Channel 5
 - ▶  Channel 6
 - ▶  Channel 7
 - ▶  Channel 8
 - ▶  Channel 9
 - ▶  Output
 - ▶  Channel 10
 - ▶  Output
 - ▶  Channel 11
 - ▶  Output
 - ▶  Channel 12
 - ▶  Output
 - ▶  Channel 13
 - ▶  Output
 - ▶  Channel 14
 - ▶  Output
 - ▶  Channel 15
 - ▶  Output
 - ▶  Channel 16
 - ▶  Output
 - ▶  WcState
 - ▶  InfoData

Data types

- ▶  Channel n
 - ▶  Output: **BIT**

3.5 EP2339-0003

3.5.1 EP2339-0003 - Introduction

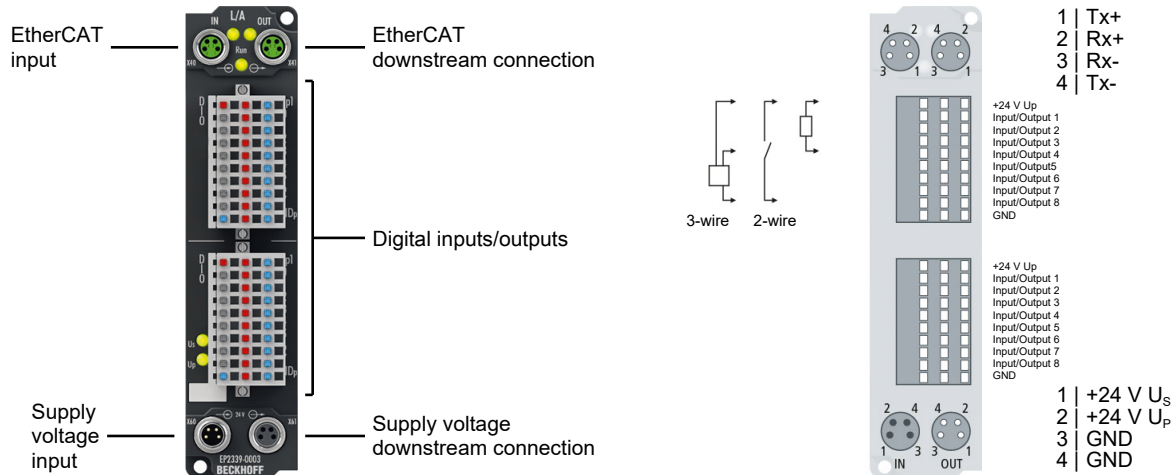

16-channel digital input or output 24 V_{DC}

The EP2339-0003 EtherCAT Box has 16 digital channels, each of which can optionally be operated as an input or as an output. A configuration for using a channel as input or output is not necessary; the input circuit is internally connected to the output driver, so that a set output is displayed automatically in the input process image.

A filter constant of 3.0 ms is available for the inputs. The outputs are short-circuit proof and protected against inverse polarity. They handle load currents of up to 0.5 A each, although the total current is limited to 4 A. The state of each signal is indicated by means of light emitting diodes on the connectors. For the signal connection connectors with a spring-loaded system are used, optionally available with 1 or 3 pins. The module is supplied without connectors. The sensors are powered by the load voltage U_P .

Quick links

- [Technical data \[▶ 41\]](#)
- [Process image \[▶ 44\]](#)
- [Dimensions \[▶ 64\]](#)
- [Signal interface \[▶ 85\]](#)

3.5.2 EP2339-0003 - Technical data

All values are typical values over the entire temperature range, unless stated otherwise.

EtherCAT	
Connection	2 x M8 socket, 4-pin, A-coded, shielded
Electrical isolation	500 V
Distributed Clocks	yes

Supply voltages	
Connection	Input: M8 connector, 4-pin, A-coded Downstream connection: M8 socket, 4-pin, A-coded
U_S nominal voltage	24 V _{DC} (-15 % / +20 %)
Current consumption from U_S	120 mA
U_S sum current: $I_{S,sum}$	max. 4 A
Rated voltage U_P	24 V _{DC} (-15 % / +20 %)
Current consumption from U_P	20 mA + Loads at digital outputs + sensor supply
U_P sum current: $I_{P,sum}$	max. 4 A
Electrical isolation GND _S / GND _P	no

Digital inputs	
Number	0 to 16 Each digital input can alternatively be used as a digital output.
Connection	2 x ZS2001 connector. Not included in the scope of delivery.
Cable length	max. 30 m
Input filter	3 ms
Characteristics	Type 3 according to EN61131-2, compatible with type 1
Signal voltage "0"	-3...+5 V
Signal voltage "1"	+11...+30 V
Input current	6 mA
Sensor power supply	24 V _{DC} from U_P . max. 0.5 A in total, short-circuit proof.

Digital outputs	
Number	0 to 16 Each digital input can alternatively be used as a digital output.
Connection	2 x ZS2001 connector. Not included in the scope of delivery.
Cable length	max. 30 m
Load type	Ohmic, inductive, lamp load
Nominal output voltage	24 V _{DC} from U_P
Output current per channel	max. 0.5 A. Each output is independently short-circuit proof.
Output sum current	max. 4 A
Short circuit current	max. 1.5 A
Changeover times	T_{ON} : 25 μ s typ., T_{OFF} : 75 μ s typ.
Output driver supply	from U_P

Housing data	
Dimensions W x H x D	30 mm x 126 mm x 26.5 mm (without connectors)
Weight	approx. 165 g
Installation position	variable
Material	PA6 (polyamide)

Environmental conditions	
Ambient temperature during operation	-25...+60 °C -25...+55 °C according to cURus
Ambient temperature during storage	-40...+85 °C
Vibration resistance, shock resistance	conforms to EN 60068-2-6 / EN 60068-2-27 Additional checks [► 42]
EMC immunity / emission	conforms to EN 61000-6-2 / EN 61000-6-4
Protection class	IP20

Additional tests

The devices have undergone the following additional tests:

Test	Explanation
Vibration	10 frequency sweeps in 3 axes
	5 Hz < f < 60 Hz displacement 0.35 mm, constant amplitude
	60.1 Hz < f < 500 Hz acceleration 5 g, constant amplitude
Shocks	1000 shocks in each direction, in 3 axes
	35 g, 11 ms

3.5.3 EP2339-0003 - Scope of supply

Make sure that the following components are included in the scope of delivery:

- 1x EtherCAT Box EP2339-0003
- 2x protective cap for EtherCAT socket, M8, green (pre-assembled)
- 1x protective cap for supply voltage input, M8, transparent (pre-assembled)
- 1x protective cap for supply voltage output, M8, black (pre-assembled)
- 10x labels, blank (1 strip of 10)

● **Pre-assembled protective caps do not ensure IP67 protection**

i Protective caps are pre-assembled at the factory to protect connectors during transport. They may not be tight enough to ensure IP67 protection.

Ensure that the protective caps are correctly seated to ensure IP67 protection.

3.5.4 EP2339-0003 - Process image

- └─ Box 1 (EP2339-0003)
 - └─ DI Inputs Channel 1
 - └─ DI Inputs Channel 2
 - └─ DO Outputs Channel 1
 - └─ DO Outputs Channel 2
 - └─ WcState
 - └─ InfoData

DI Inputs Channel *n*

- └─ DI Inputs Channel 1
 - └─ Input 1
 - └─ Input 2
 - └─ Input 3
 - └─ Input 4
 - └─ Input 5
 - └─ Input 6
 - └─ Input 7
 - └─ Input 8
 - └─ Sync error
 - └─ TxPDO State
 - └─ TxPDO Toggle
- └─ DI Inputs Channel 2
 - └─ Input 1
 - └─ Input 2
 - └─ Input 3
 - └─ Input 4
 - └─ Input 5
 - └─ Input 6
 - └─ Input 7
 - └─ Input 8
 - └─ Sync error
 - └─ TxPDO State
 - └─ TxPDO Toggle

Input *x*

Digital inputs. Data type: BIT.

Sync error

This bit is only relevant in Distributed Clocks mode.

It is TRUE if a synchronization error occurred during the elapsed EtherCAT cycle.

TxPDO State









Validity of the input data. This bit is TRUE if the input data could not be read correctly due to an error.

TxPDO Toggle









This bit is inverted each time an input data update occurs.

DO Outputs Channel *n*

▲  DO Outputs Channel 1

-  Output 1
-  Output 2
-  Output 3
-  Output 4
-  Output 5
-  Output 6
-  Output 7
-  Output 8

▲  DO Outputs Channel 2

-  Output 1
-  Output 2
-  Output 3
-  Output 4
-  Output 5
-  Output 6
-  Output 7
-  Output 8

 **Output *x***
Digital outputs. Data type: BIT.

3.6 EP2339-002x, EP2349-002x

3.6.1 EP23x9-0021 - Introduction

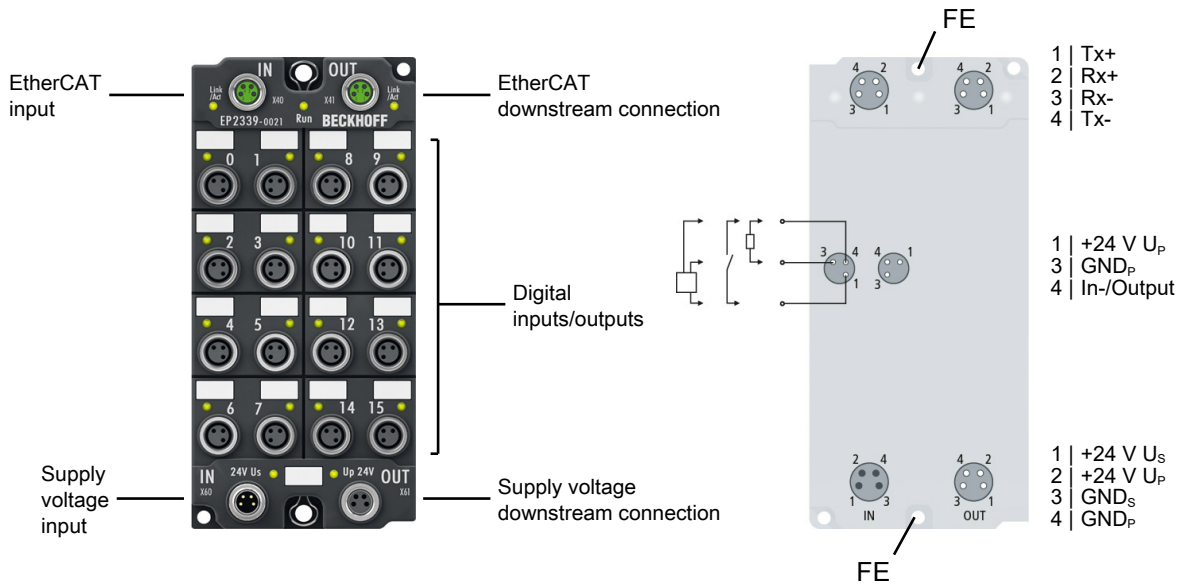

16 digital inputs or outputs, 24 V_{DC}

The EP23x9-0021 EtherCAT Box has 16 digital channels that can each be operated as inputs or outputs. It is not necessary to configure whether a channel (pin 2 and 4 of the M12) is to be used as input or output; the input circuit is permanently connected internally to the output driver, so that a set output is automatically displayed in the input process image.

The inputs of the EP2339-0021 have a filter of 3.0 ms.
 The inputs of the EP2349-0021 have a filter of 10 μs.

The outputs handle load currents up to 0.5 A and are short-circuit-proof and protected against reverse polarity. The total current of all outputs is limited to 4 A.

The connected sensors are supplied by an internal, short-circuit-proof driver module with a total of 0.5 A for all sensors. The inputs and outputs are supplied via U_P. The signal status is indicated by LEDs. The signals are connected via M12 connectors.

● Supply of the connected sensors from U_P, not from U_S

I In contrast to many other modules, the EP23x9-0021 EtherCAT Box supplies digital sensors from the U_P peripheral voltage and not from the U_S control voltage! Nevertheless, an overload of the sensor supply (current > 0.5 A) is also indicated here by the illuminated red U_S LED.

NOTICE

For shutdown in the event of a fault, do not supply sensors externally

If the design of your installation is such that the power supply voltage U_P is switched off in the event of a fault, you must not power the connected sensors externally, but only through EP23x9-0021! Otherwise, when the U_P energy is switched off, EP23x9-0021 can continue to draw energy from the external sensor supply, and the outputs will not be switched off.

Quick links

- [Technical data \[▶ 48\]](#)
- [Process image \[▶ 51\]](#)
- [Dimensions \[▶ 66\]](#)
- [Signal interface \[▶ 86\]](#)

3.6.2 EP23x9-0022 - Introduction

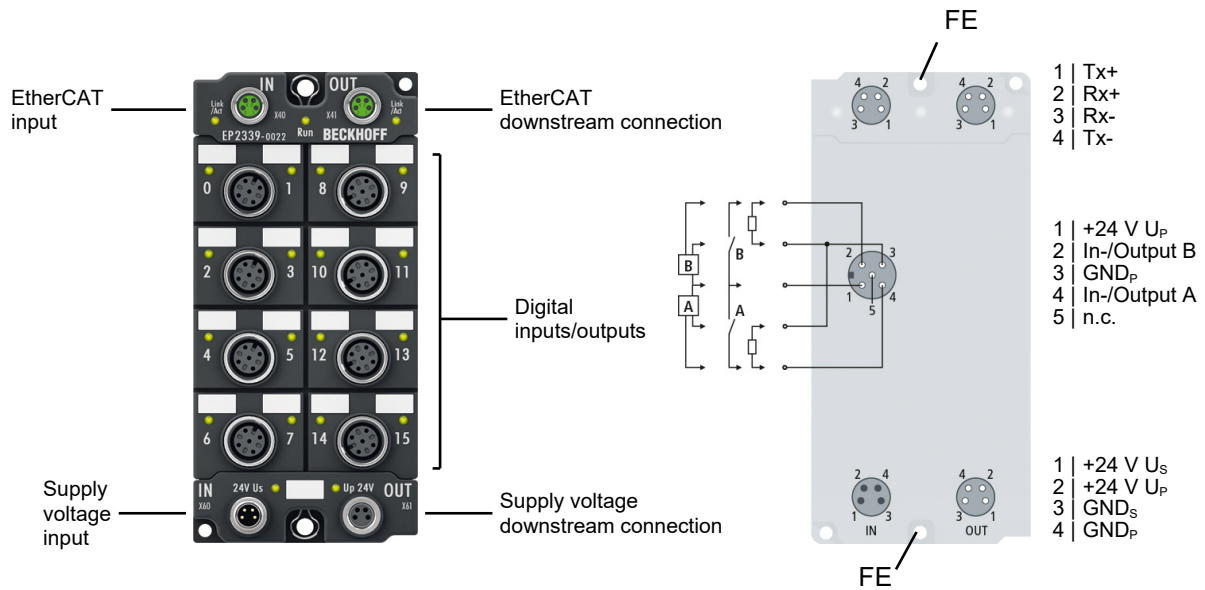

16 digital inputs or outputs, 24 V_{DC}

The EP23x9-0022 EtherCAT Box has 16 digital channels that can each be operated as inputs or outputs. It is not necessary to configure whether a channel (pin 2 and 4 of the M12) is to be used as input or output; the input circuit is permanently connected internally to the output driver, so that a set output is automatically displayed in the input process image. The outputs process load currents up to 0.5 A, are short-circuit proof and protected against inverse polarity.

The inputs of the EP2339-0022 have a filter of 3.0 ms.
 The inputs of the EP2349-0022 have a filter of 10 µs.

The outputs handle load currents up to 0.5 A and are short-circuit-proof and protected against reverse polarity. The total current of all outputs is limited to 4 A.

The connected sensors are supplied by an internal, short-circuit-proof driver module with a total of 0.5 A for all sensors. The inputs and outputs are supplied via U_P. The signal status is indicated by LEDs. The signals are connected via M12 connectors.

● Supply of the connected sensors from U_P, not from U_S

I In contrast to many other modules, the EP23x9-0022 EtherCAT Box supplies digital sensors from the U_P peripheral voltage and not from the U_S control voltage! Nevertheless, an overload of the sensor supply (current > 0.5 A) is also indicated here by the illuminated red U_S LED.

NOTICE

For switch-off in the event of a fault, do not supply sensors externally

If the design of your installation is such that the power supply voltage U_P is switched off in the event of a fault, you must not power the connected sensors externally, but only through EP23x9-0022! Otherwise, when the U_P energy is switched off, EP23x9-0022 can continue to draw energy from the external sensor supply, and the outputs will not be switched off.

Quick links

- [Technical data \[▶ 48\]](#)
- [Process image \[▶ 51\]](#)
- [Dimensions \[▶ 67\]](#)
- [Signal interface \[▶ 87\]](#)

3.6.3 EP23x9-002x - Technical data

All values are typical values over the entire temperature range, unless stated otherwise.

EtherCAT	
Connection	2 x M8 socket, 4-pin, A-coded, shielded
Electrical isolation	500 V

Supply voltages	
Connection	Input: M8 connector, 4-pin, A-coded Downstream connection: M8 socket, 4-pin, A-coded
U_S nominal voltage	24 V _{DC} (-15 % / +20 %)
Current consumption from U_S	120 mA
U_S sum current: $I_{S,sum}$	max. 4 A
Rated voltage U_P	24 V _{DC} (-15 % / +20 %)
Current consumption from U_P	20 mA + Loads at digital outputs + sensor supply
U_P sum current: $I_{P,sum}$	max. 4 A
Electrical isolation GND _S / GND _P	yes

Digital inputs	EP2339-0021	EP2339-0022	EP2349-0021	EP2349-0022
Number	0 to 16 Each digital input can alternatively be used as a digital output.			
Connection	16 x M8 socket	8 x M12 socket	16 x M8 socket	8 x M12 socket
Cable length	max. 30 m			
Input filter	3.0 ms	3.0 ms	10 μs	10 μs
Characteristics	Type 3 according to EN61131-2, compatible with type 1			
Signal voltage "0"	-3...+5 V			
Signal voltage "1"	+11...+30 V			
Input current	6 mA			
Sensor power supply	24 V _{DC} from U_P . max. 0.5 A in total, short-circuit proof.			

Digital outputs	EP2339-0021	EP2339-0022	EP2349-0021	EP2349-0022
Number	0 to 16 Each digital output can alternatively be used as a digital input.			
Connection	16 x M8 socket	8 x M12 socket	16 x M8 socket	8 x M12 socket
Cable length	max. 30 m			
Load type	Ohmic, inductive, lamp load			
Nominal output voltage	24 V _{DC}			
Output current per channel	max. 0.5 A. Each output is independently short-circuit proof.			
Output sum current	max. 4 A			
Short circuit current	max. 1.5 A			
Output driver supply	From the peripheral voltage U_P .			
Changeover times	T_{ON} : 60 μs typ., T_{OFF} : 300 μs typ.			

Housing data	
Dimensions W x H x D	60 mm x 126 mm x 26.5 mm (without plug connectors)
Weight	approx. 250 g
Installation position	variable
Material	PA6 (polyamide)

Environmental conditions	
Ambient temperature during operation	-25 ... +60 °C -25 ... +55 °C according to cURus
Ambient temperature during storage	-40 ... +85 °C
Vibration resistance, shock resistance	conforms to EN 60068-2-6 / EN 60068-2-27 Additional tests [► 49]
EMC immunity / emission	conforms to EN 61000-6-2 / EN 61000-6-4
Protection class	IP65, IP66, IP67 (conforms to EN 60529)

Approvals/markings	
Approvals/markings *)	CE, cURus [► 90]

*) Real applicable approvals/markings see type plate on the side (product marking).

Additional tests

The devices have undergone the following additional tests:

Test	Explanation
Vibration	10 frequency sweeps in 3 axes
	5 Hz < f < 60 Hz displacement 0.35 mm, constant amplitude
	60.1 Hz < f < 500 Hz acceleration 5 g, constant amplitude
Shocks	1000 shocks in each direction, in 3 axes
	35 g, 11 ms

3.6.4 EP23x9-002x - Scope of supply

Make sure that the following components are included in the scope of delivery:

- 1x EtherCAT Box EP23x9-002x
- 2x protective cap for EtherCAT socket, M8, green (pre-assembled)
- 1x protective cap for supply voltage input, M8, transparent (pre-assembled)
- 1x protective cap for supply voltage output, M8, black (pre-assembled)
- 10x labels, blank (1 strip of 10)

● **Pre-assembled protective caps do not ensure IP67 protection**

i Protective caps are pre-assembled at the factory to protect connectors during transport. They may not be tight enough to ensure IP67 protection.

Ensure that the protective caps are correctly seated to ensure IP67 protection.

3.6.5 EP23x9-002x - Process image

Inputs

Under **Channel 1** to **Channel 16** you will find the 16 digital inputs of the module (here as an example the EP2339-0021).

- └─ Box 1 (EP2339-0021)
 - └─ Channel 1
 - └─ Input
 - └─ Channel 2
 - └─ Channel 3
 - └─ Channel 4
 - └─ Channel 5
 - └─ Channel 6
 - └─ Channel 7
 - └─ Channel 8
 - └─ Channel 9
 - └─ Channel 10
 - └─ Channel 11
 - └─ Channel 12
 - └─ Channel 13
 - └─ Channel 14
 - └─ Channel 15

Data types

- └─ Channel n
 - └─ Input: **BIT**

Outputs

Under **Channel 17** to **Channel 32** you will find the 16 digital outputs of the module (here as an example the EP2339-0021).

- └─ Channel 17
 - └─ Output
- └─ Channel 18
- └─ Channel 19
- └─ Channel 20
- └─ Channel 21
- └─ Channel 22
- └─ Channel 23
- └─ Channel 24
- └─ Channel 25
- └─ Channel 26
- └─ Channel 27
- └─ Channel 28
- └─ Channel 29
- └─ Channel 30
- └─ Channel 31
- └─ Channel 32
- └─ WcState
- └─ InfoData

Data types

- └─ Channel n
 - └─ Output: **BIT**

3.7 EP2339-0042

3.7.1 EP2339-0042 - Introduction

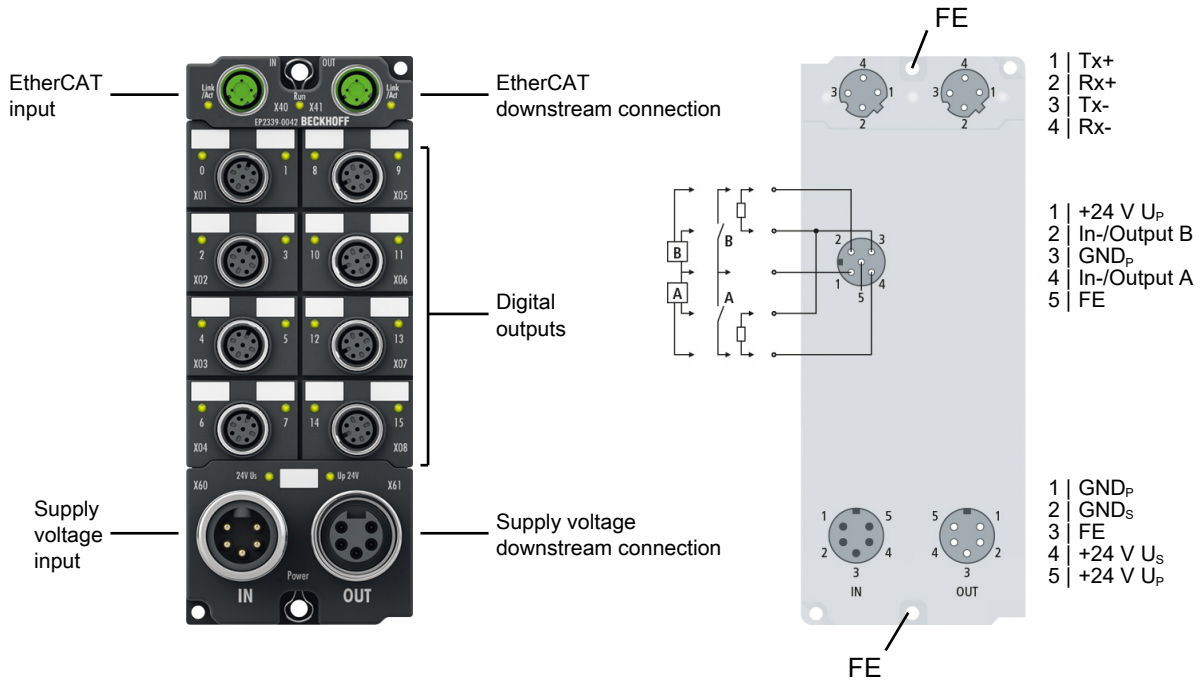

16-channel digital input or output 24 V DC

The EP2339-0042 EtherCAT Box has 16 digital channels, each of which can optionally be operated as an input or as an output. A configuration for using a channel as input or output is not necessary; the input circuit is internally connected to the output driver, so that a set output is displayed automatically in the input process image.

A filter constant of 3.0 ms is available for the inputs. The outputs are short-circuit proof. They handle load currents of up to 0.5 A each. The state of each signal is indicated by means of light emitting diodes. The signals are connected via M12 screw type connectors.

The EP2339-0042 is interference-free. You can use the EP2339-0042 instead of an interference-free standard terminal in accordance with the following chapters of the [TwinSAFE Application Guide](#):

- "All-pole disconnection of a potential group with downstream interference-free standard terminals (Category 4, PL e)"
- "Single-pole disconnection of a potential group with downstream interference-free standard terminals with fault exclusion (Category 4, PL e)"
- „EL2911 potential group with interference-free standard terminals (Category 4, PL e)"

i Supply of the connected sensors from U_P , not from U_S

In contrast to many other modules, the EP2339-0042 EtherCAT Box supplies digital sensors from the U_P peripheral voltage and not from the U_S control voltage.

NOTICE

For shutdown in the event of a fault, do not supply sensors externally

If the design of your installation is such that the power supply voltage U_P is switched off in the event of a fault, you must not power the connected sensors externally, but only through the EP2339-0042! Otherwise, when the U_P energy is switched off, the EP2339-0042 can continue to draw energy from the external sensor supply, and the outputs will not be switched off.

Quick links

[Technical data \[▶ 54\]](#)

[Process image \[▶ 57\]](#)

[Dimensions \[▶ 68\]](#)

[Signal interface \[▶ 88\]](#)

3.7.2 EP2339-0042 - Technical data

All values are typical values over the entire temperature range, unless stated otherwise.

EtherCAT	
Connection	2 x M12 socket, 4-pin, D-coded, shielded
Electrical isolation	500 V

Supply voltages	
Connection	Input: 7/8" plug, 5-pin, 16-UN thread Downstream connection: 7/8" socket, 5-pin, 16-UN thread
U_s nominal voltage	24 V _{DC} (-15 % / +20 %)
U_s sum current	max. 16 A at 40 °C
Current consumption from U_s	120 mA
Rated voltage U_p	24 V _{DC} (-15 % / +20 %)
U_p sum current	max. 16 A at 40 °C
Current consumption from U_p	20 mA + Loads at digital outputs + sensor supply
Electrical isolation GND _s / GND _p	yes

Digital inputs	
Number	0 to 16 Each digital input can alternatively be used as a digital output.
Connection	8 x M12 socket
Cable length	max. 30 m
Input filter	3 ms
Characteristics	Type 3 according to EN61131-2, compatible with type 1
Signal voltage "0"	-3...+5 V
Signal voltage "1"	+11...+30 V
Input current	6 mA
Sensor power supply	24 V _{DC} from U_p . max. 0.5 A in total, short-circuit proof.

Digital outputs	
Number	0 to 16 Each digital output can alternatively be used as a digital input.
Connection	8 x M12
Cable length	max. 30 m
Load type	Ohmic, inductive, lamp load
Nominal output voltage	24 V _{DC} from U_p
Output current per channel	max. 0.5 A. Each output is independently short-circuit proof.
Short circuit current	1.9 A typ.
Output driver supply	from U_p
Changeover times	T_{ON} : 60 µs typ., T_{OFF} : 300 µs typ.

Housing data	
Dimensions W x H x D	60 mm x 150 mm x 26,5 mm (without connectors)
Weight	approx. 440 g
Installation position	variable
Material	PA6 (polyamide)

Environmental conditions	
Ambient temperature during operation	-25 ... +60 °C
Ambient temperature during storage	-40 ... +85 °C
Vibration / shock resistance	conforms to EN 60068-2-6 / EN 60068-2-27
EMC immunity / emission	conforms to EN 61000-6-2 / EN 61000-6-4
Protection class	IP65, IP66, IP67 conforms to EN 60529

Approvals / markings	
Approvals / markings *)	CE, UL under preparation

*) Real applicable approvals/markings see type plate on the side (product marking).

Additional tests

The devices have undergone the following additional tests:

Test	Explanation
Vibration	10 frequency sweeps in 3 axes
	5 Hz < f < 60 Hz displacement 0.35 mm, constant amplitude
	60.1 Hz < f < 500 Hz acceleration 5 g, constant amplitude
Shocks	1000 shocks in each direction, in 3 axes
	35 g, 11 ms

3.7.3 EP2339-0042 - Scope of supply

Make sure that the following components are included in the scope of delivery:

- 1x EtherCAT Box EP2339-0042
- 2x protective cap for EtherCAT socket, M12 (pre-assembled)
- 1x Protective cap for supply voltage output, 7/8", black (pre-fitted)
- 10x labels, blank (1 strip of 10)



Pre-assembled protective caps do not ensure IP67 protection

Protective caps are pre-assembled at the factory to protect connectors during transport. They may not be tight enough to ensure IP67 protection.

Ensure that the protective caps are correctly seated to ensure IP67 protection.

3.7.4 EP2339-0042 - Process image

Inputs

The process image contains a process data object for each digital input.

The name of each process data object contains the name of the socket and the pin number of the corresponding digital input.

- DI X01 Pin4
 - Input
 - DI X01 Pin2
 - DI X02 Pin4
 - DI X02 Pin2
 - DI X03 Pin4
 - DI X03 Pin2
 - DI X04 Pin4
 - DI X04 Pin2
 - DI X05 Pin4
 - DI X05 Pin2
 - DI X06 Pin4
 - DI X06 Pin2
 - DI X07 Pin4
 - DI X07 Pin2
 - DI X08 Pin4
 - DI X08 Pin2

Data types

Input: **BIT**

Outputs

The process image contains a process data object for each digital output.

The name of each process data object contains the name of the socket and the pin number of the corresponding digital output.

- DO X01 Pin 4
 - Output
 - DO X01 Pin 2
 - DO X02 Pin 4
 - DO X02 Pin 2
 - DO X03 Pin 4
 - DO X03 Pin 2
 - DO X04 Pin 4
 - DO X04 Pin 2
 - DO X05 Pin 4
 - DO X05 Pin 2
 - DO X06 Pin
 - DO X06 Pin
 - DO X07 Pin
 - DO X07 Pin
 - DO X08 Pin
 - DO X08 Pin
 - WcState
 - InfoData

Data types

Output: **BIT**

3.8 EP2339-0121

3.8.1 EP2339-0121 - Introduction

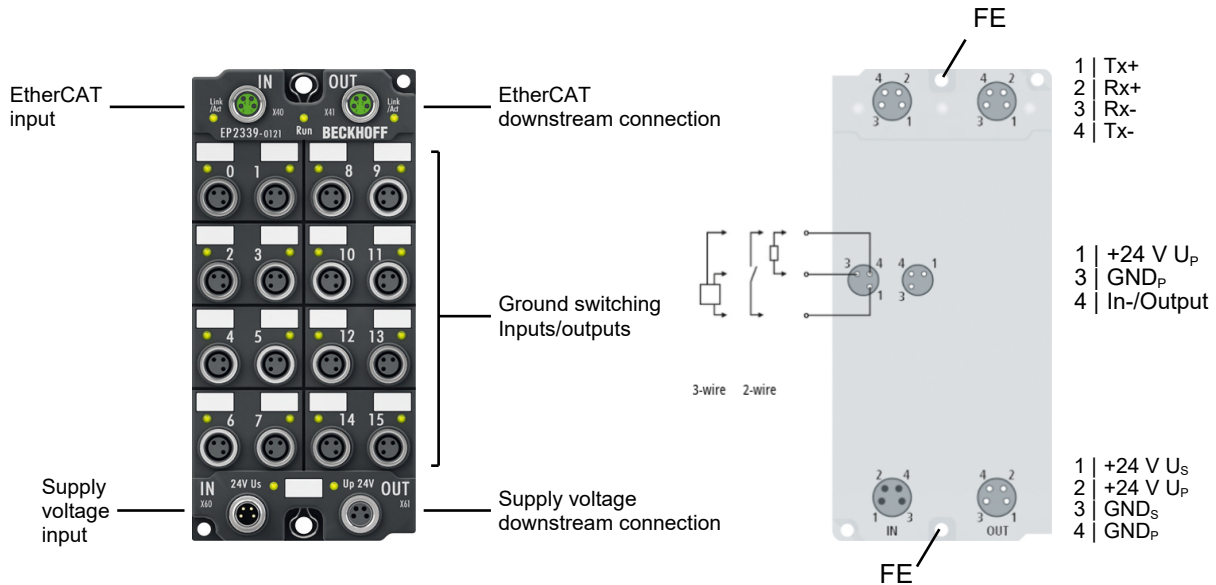

16-channel digital input or output 24 V_{DC}, ground switching

The EP2339-0121 EtherCAT Box has 16 digital channels that can each be operated as inputs or outputs. It is not necessary to configure whether a channel (pin 4 of the M8) is to be used as input or output; the input circuit is permanently connected internally to the output driver, so that a set output is automatically displayed in the input process image. Inputs and outputs are ground switching.

The inputs have a filter of 3.0 ms. The outputs handle load currents up to 0.5 A and are short-circuit-proof and protected against reverse polarity. The total current of all outputs is limited to 4 A.

The connected sensors are supplied by an internal, short-circuit-proof driver module with a total of 0.5 A for all sensors. The inputs and outputs are supplied via U_P. The signal status is indicated by LEDs. The signals are connected via M8 connectors.

Quick links

- [Technical data \[► 59\]](#)
- [Process image \[► 61\]](#)
- [Dimensions \[► 66\]](#)
- [Signal interface \[► 89\]](#)

3.8.2 EP2339-0121 - Technical data

All values are typical values over the entire temperature range, unless stated otherwise.

EtherCAT	
Connection	2 x M8 socket, 4-pin, A-coded, shielded
Electrical isolation	500 V

Supply voltages	
Connection	Input: M8 connector, 4-pin, A-coded Downstream connection: M8 socket, 4-pin, A-coded
U_S nominal voltage	24 V _{DC} (-15 % / +20 %)
U_S sum current: $I_{S,sum}$	max. 4 A
Current consumption from U_S	60 mA
Rated voltage U_P	24 V _{DC} (-15 % / +20 %)
U_P sum current: $I_{P,sum}$	max. 4 A
Current consumption from U_P	50 mA + sensor supply

Digital inputs	
Number	0 to 16 Each digital input can alternatively be used as a digital output.
Connection	16 x M8 socket
Cable length	max. 30 m
Input filter	3.0 ms
Characteristics	Ground switching
Signal voltage "0"	18...30 V
Signal voltage "1"	0...7 V
Sensor power supply	24 V _{DC} from U_P . max. 0.5 A in total, short-circuit proof.

Digital outputs	
Number	0 to 16 Each digital output can alternatively be used as a digital input.
Connection	16 x M8 socket
Cable length	max. 30 m
Characteristics	Ground switching
Load current	max. 0.5 A
Changeover times	T_{ON} : 60 μ s typ., T_{OFF} : 300 μ s typ.

Housing data	
Dimensions W x H x D	60 mm x 126 mm x 26.5 mm (without plug connectors)
Weight	approx. 260 g
Installation position	variable
Material	PA6 (polyamide)

Environmental conditions	
Ambient temperature during operation	-25 ... +60 °C -25 ... +55 °C according to cURus
Ambient temperature during storage	-40 ... +85 °C
Vibration resistance, shock resistance	conforms to EN 60068-2-6 / EN 60068-2-27 Additional tests [► 55]
EMC immunity / emission	conforms to EN 61000-6-2 / EN 61000-6-4
Protection class	IP65, IP66, IP67 (conforms to EN 60529)

Approvals/markings	
Approvals/markings *)	CE, cURus [► 90]

*) Real applicable approvals/markings see type plate on the side (product marking).

3.8.3 EP2339-0121 - Scope of supply

Make sure that the following components are included in the scope of delivery:

- 1x EP2339-0121
- 2x protective cap for EtherCAT socket, M8, green (pre-assembled)
- 1x protective cap for supply voltage input, M8, transparent (pre-assembled)
- 1x protective cap for supply voltage output, M8, black (pre-assembled)
- 10x labels, blank (1 strip of 10)

i Pre-assembled protective caps do not ensure IP67 protection

Protective caps are pre-assembled at the factory to protect connectors during transport. They may not be tight enough to ensure IP67 protection.

Ensure that the protective caps are correctly seated to ensure IP67 protection.

4 Mounting and connection

4.1 Mounting

4.1.1 EPxxxx-x001 dimensions

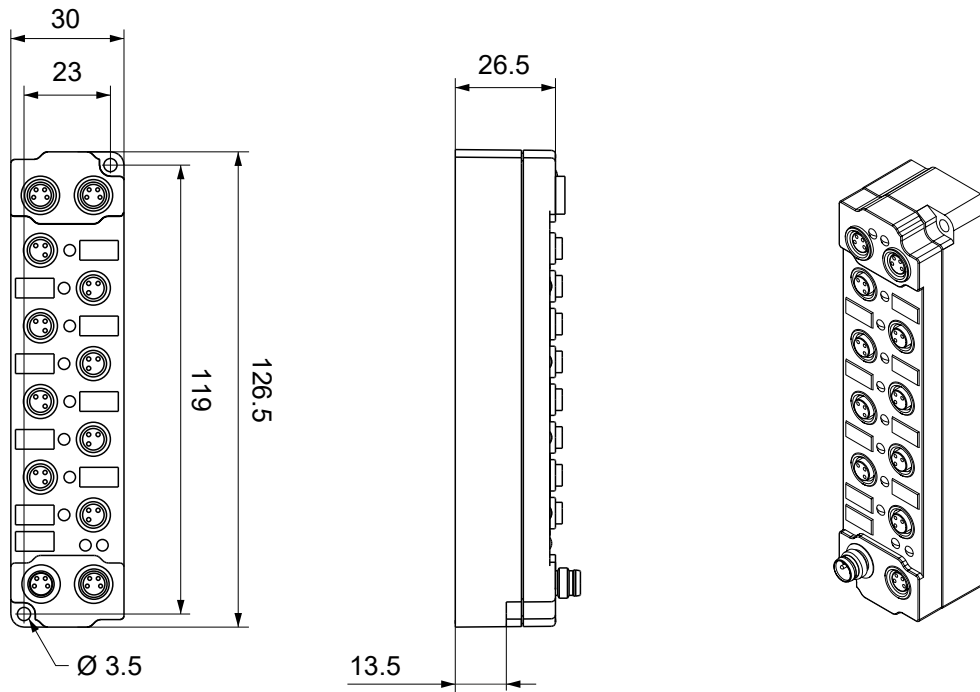

All dimensions are given in millimeters.
The drawing is not true to scale.

Housing features

Housing material	PA6 (polyamide)
Sealing compound	polyurethane
Mounting	two mounting holes $\varnothing 3.5$ mm for M3
Metal parts	brass, nickel-plated
Contacts	CuZn, gold-plated
Power feed through	max. 4 A
Installation position	variable
Protection class	IP65, IP66, IP67 (conforms to EN 60529) when screwed together
Dimensions (H x W x D)	approx. 126 x 30 x 26.5 mm (without connectors)

4.1.2 EPxxxx-x002 dimensions

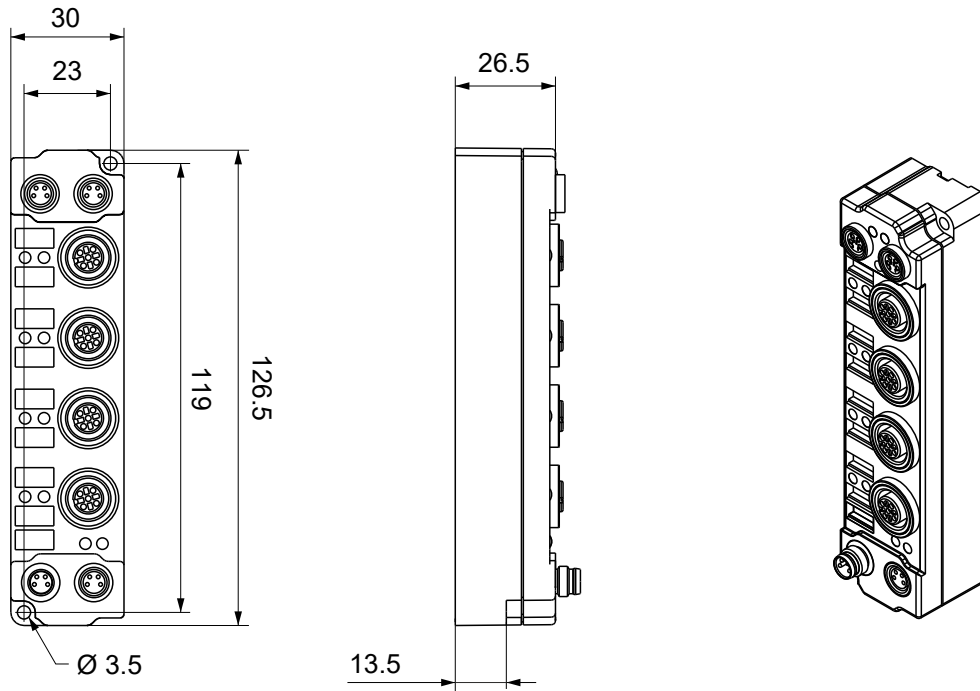

All dimensions are given in millimeters.
The drawing is not true to scale.

Housing features

Housing material	PA6 (polyamide)
Sealing compound	polyurethane
Mounting	two mounting holes $\varnothing 3.5$ mm for M3
Metal parts	brass, nickel-plated
Contacts	CuZn, gold-plated
Power feed through	max. 4 A
Installation position	variable
Protection class	IP65, IP66, IP67 (conforms to EN 60529) when screwed together
Dimensions (H x W x D)	approx. 126 x 30 x 26.5 mm (without connectors)

4.1.3 EPxxxx-0003 dimensions

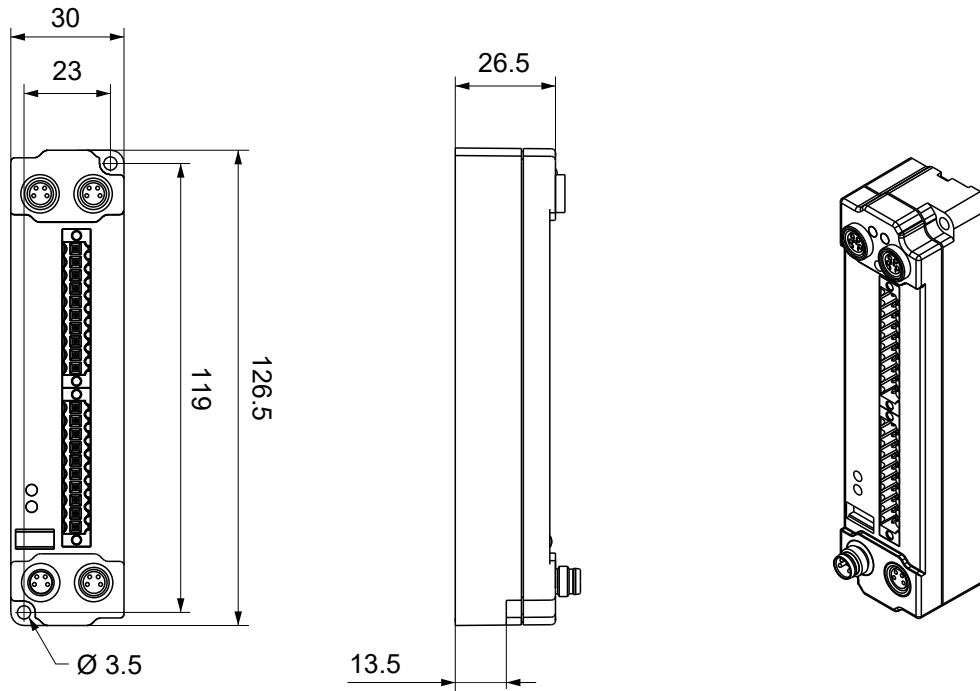

All dimensions are given in millimeters.
The drawing is not true to scale.

Housing features

Housing material	PA6 (polyamide)
Sealing compound	polyurethane
Mounting	two mounting holes $\varnothing 3.5$ mm for M3
Metal parts	brass, nickel-plated
Contacts	CuZn, gold-plated
Power feed through	max. 4 A
Installation position	variable
Protection class	IP65, IP66, IP67 (conforms to EN 60529) when screwed together
Dimensions (H x W x D)	approx. 126 x 30 x 26.5 mm (without connectors)

4.1.4 EPxxxx-0008 dimensions

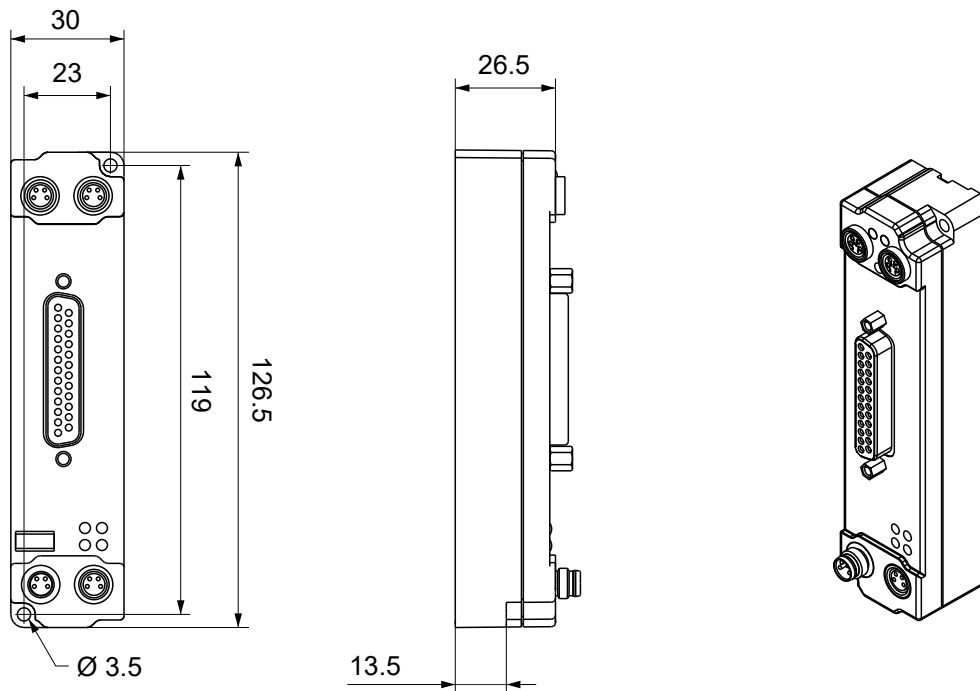

All dimensions are given in millimeters.
The drawing is not true to scale.

Housing features

Housing material	PA6 (polyamide)
Sealing compound	polyurethane
Mounting	two mounting holes Ø 3.5 mm for M3
Metal parts	brass, nickel-plated
Contacts	CuZn, gold-plated
Power feed through	max. 4 A
Installation position	variable
Protection class	IP65, IP66, IP67 (conforms to EN 60529) when screwed together
Dimensions (H x W x D)	approx. 126 x 30 x 26.5 mm (without connectors)

4.1.5 EPxxxx-0x21 dimensions

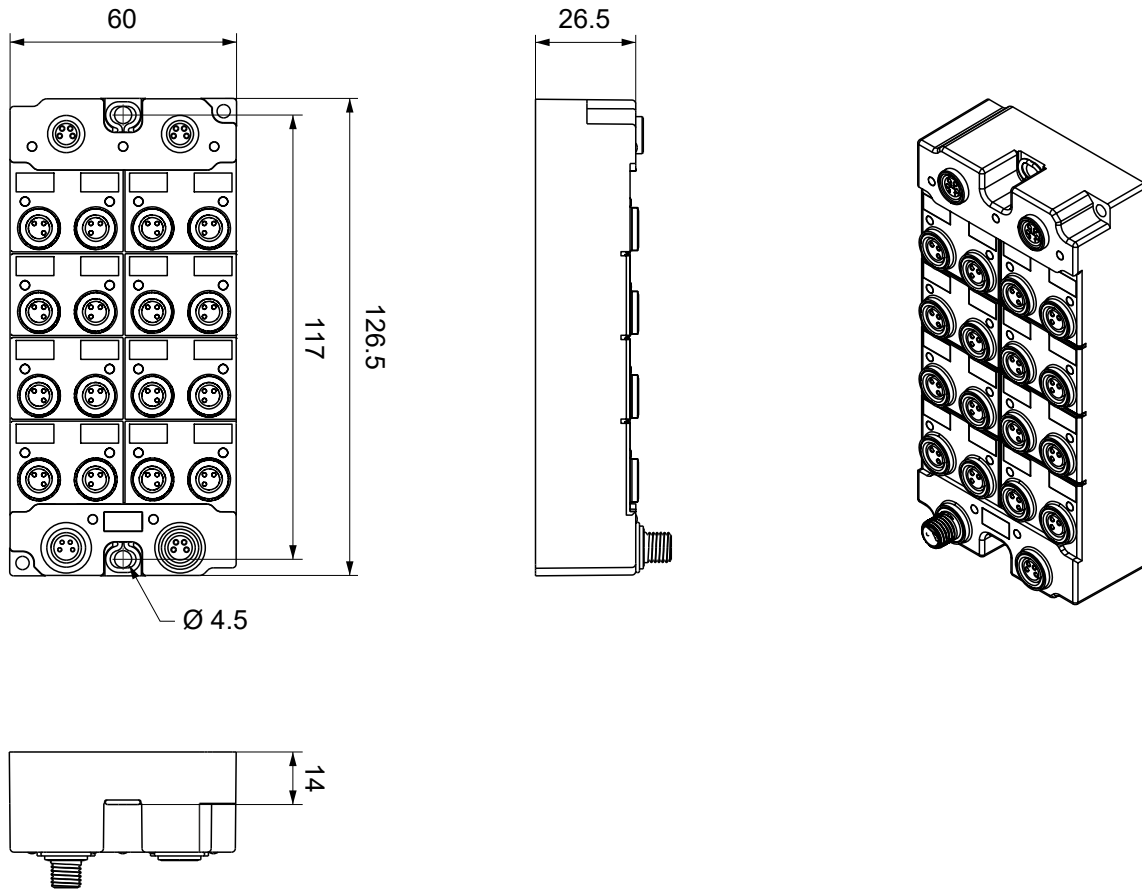

All dimensions are given in millimeters.
The drawing is not true to scale.

Housing features

Housing material	PA6 (polyamide)
Sealing compound	polyurethane
Mounting	two mounting holes $\varnothing 4.5$ mm for M4
Metal parts	brass, nickel-plated
Contacts	CuZn, gold-plated
Installation position	variable
Protection class	IP65, IP66, IP67 (conforms to EN 60529) when screwed together
Dimensions (H x W x D)	approx. 126 x 60 x 26.5 mm (without connectors)

4.1.6 EPxxxx-0022 dimensions

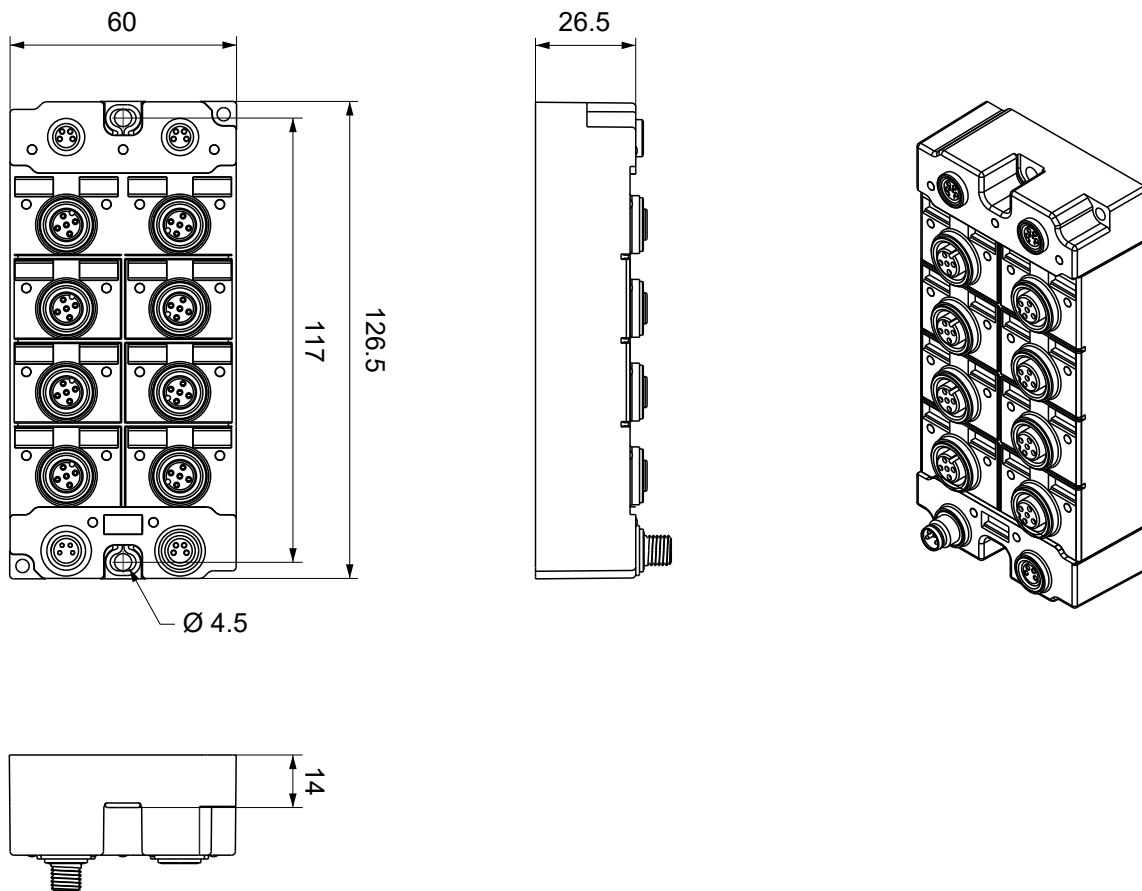

All dimensions are given in millimeters.
The drawing is not true to scale.

Housing features

Housing material	PA6 (polyamide)
Sealing compound	polyurethane
Mounting	two mounting holes Ø 4.5 mm for M4
Metal parts	brass, nickel-plated
Contacts	CuZn, gold-plated
Installation position	variable
Protection class	IP65, IP66, IP67 (conforms to EN 60529) when screwed together
Dimensions (H x W x D)	approx. 126 x 60 x 26.5 mm (without connectors)

4.1.7 EPxxxx-0042 dimensions

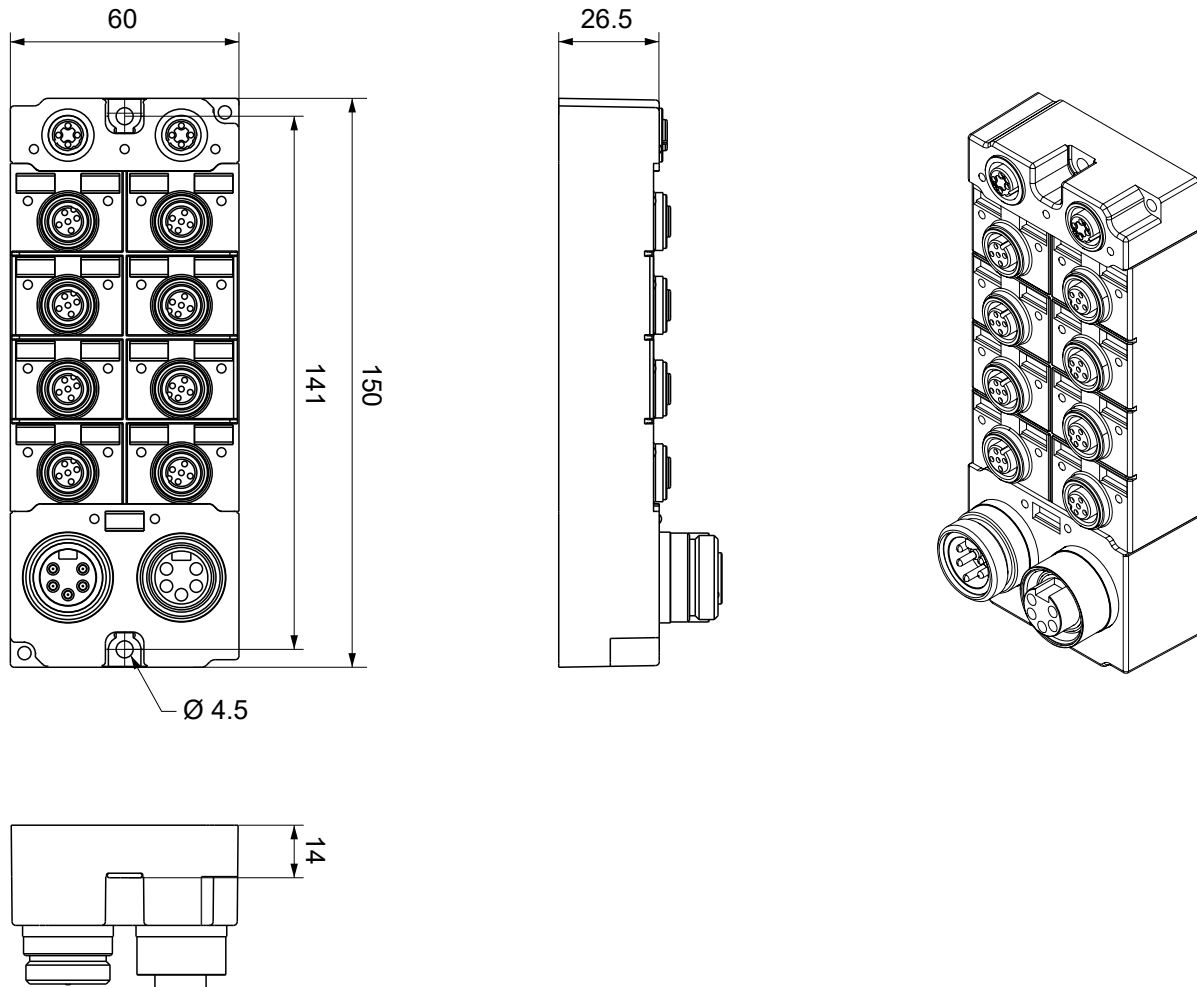

All dimensions are given in millimeters.
The drawing is not true to scale.

Housing features

Housing material	PA6 (polyamide)
Sealing compound	polyurethane
Mounting	two mounting holes Ø 4.5 mm for M4
Metal parts	brass, nickel-plated
Contacts	CuZn, gold-plated
Power feed through	max. 16 A at 40°C (according to IEC 60512-3)
Installation position	variable
Protection class	IP65, IP66, IP67 (conforms to EN 60529) when screwed together
Dimensions (H x W x D)	approx. 150 x 60 x 26.5 mm (without connectors)

4.1.8 Fixing

● Protection of connectors against contamination!

i While mounting the modules, protect all connectors, against contamination! Only with connected cables or plugs the protection class IP67 is guaranteed! Unused connectors have to be protected with the right plugs! See for plug sets in the catalogue.

Modules with narrow housing are mounted with two M3 bolts.

Modules with wide housing are mounted with two M3 bolts to the mounting holes located at the corners or mounted with two M4 bolts to the mounting holes located centrally.

The bolts must be longer than 15 mm. The mounting holes of the modules are not threaded.

When assembling, remember that the fieldbus connectors increases the overall height. See chapter accessories.

Mounting Rail ZS5300-0001

The mounting rail ZS5300-0001 (500 mm x 129 mm) allows the time saving assembly of modules.

The rail is made of stainless steel, 1.5 mm thick, with already pre-made M3 threads for the modules. The rail has got 5.3 mm slots to mount it via M5 screws to the machine.

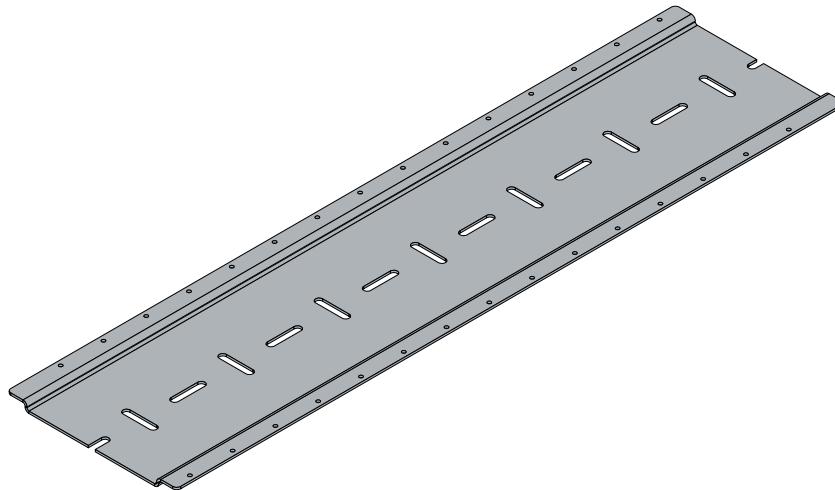

Fig. 5: Mounting Rail ZS5300-000

The mounting rail is 500 mm long, that way 15 narrow modules can be mounted with a distance of 2 mm between two modules. The rail can be cut to length for the application.

Mounting Rail ZS5300-0011

The mounting rail ZS5300-0011 (500 mm x 129 mm) has in addition to the M3 threads also pre-made M4 threads to fix 60 mm wide modules via their middle holes.

Up to 14 narrow or 7 wide modules may be mixed mounted.

4.1.9 Functional earth (FE)

EtherCAT Box modules of types EPxxxx-002x and EPxxxx-0042 must be grounded:

The Fixing also serve as connections for the functional earth (FE).

Make sure that the box is earthed with low impedance via both fastening screws. You can achieve this, for example, by mounting the box on a grounded machine bed.

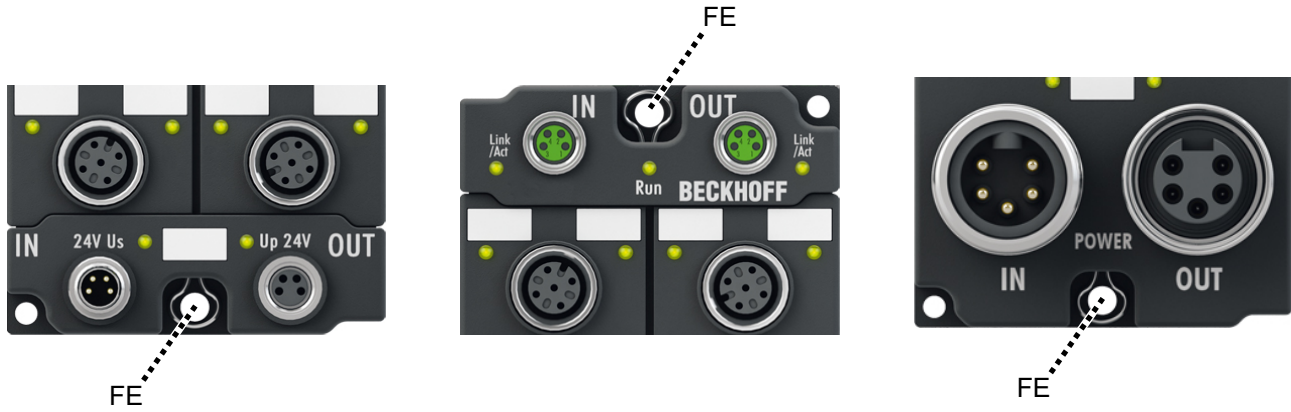

Fig. 6: Functional earth via the fastening holes

4.2 Connections

4.2.1 Tightening torques for plug connectors

Screw connectors tight with a torque wrench. (e.g. ZB8801 from Beckhoff)

Connector diameter	Tightening torque
M8	0.4 Nm
M12	0.6 Nm
7/8"	1.5 Nm

4.2.2 EtherCAT

4.2.2.1 Connectors

NOTICE

Risk of confusion: supply voltages and EtherCAT

Defect possible through incorrect insertion.

- Observe the color coding of the connectors:
 black: Supply voltages
 green: EtherCAT

EtherCAT Box modules have two green M8 or M12 sockets for the incoming and outgoing EtherCAT connections.

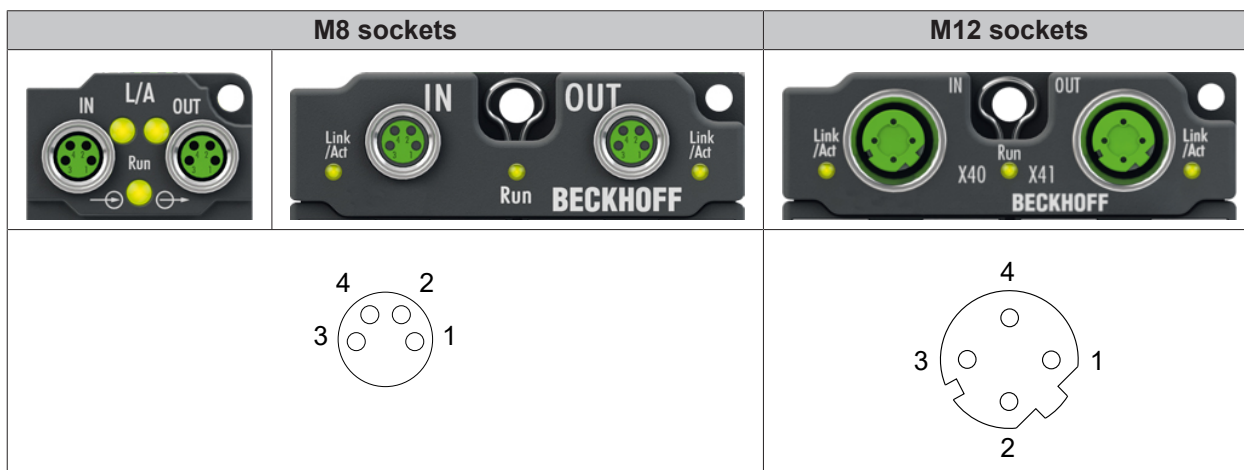

Assignment

There are various different standards for the assignment and colors of connectors and cables for EtherCAT.

EtherCAT	Plug connector			Cable		Standard
	M8	M12	RJ45 ¹	ZB9010, ZB9020, ZB9030, ZB9032, ZK1090-6292, ZK1090-3xxx-xxxx	ZB9031 and old versions of ZB9030, ZB9032, ZK1090-3xxx-xxxx	
Signal						TIA-568B
Tx +	Pin 1	Pin 1	Pin 1	yellow ²	orange/white ³	white/orange
Tx -	Pin 4	Pin 3	Pin 2	orange ²	orange ³	orange
Rx +	Pin 2	Pin 2	Pin 3	white ²	blue/white ³	white/green
Rx -	Pin 3	Pin 4	Pin 6	blue ²	blue ³	green
Shield	Housing		Shroud	Shield	Shield	Shield

¹) colored markings according to EN 61918 in the four-pin RJ45 connector ZS1090-0003

²) wire colors according to EN 61918

³) wire colors

i Assimilation of color coding for cable ZB9030, ZB9032 and ZK1090-3xxxx-xxxx (with M8 connectors)

For unification, the prevalent cables ZB9030, ZB9032 and ZK1090-3xxx-xxxx were changed to the colors of EN61918 (yellow, orange, white, blue). So different color coding exists. But the electrical properties are absolutely identical.

4.2.2.2 Status LEDs



L/A (Link/Act)

A green LED labelled "L/A" is located next to each EtherCAT socket. The LED indicates the communication state of the respective socket:

LED	Meaning
off	no connection to the connected EtherCAT device
lit	LINK: connection to the connected EtherCAT device
flashes	ACT: communication with the connected EtherCAT device

Run

Each EtherCAT slave has a green LED labelled "Run". The LED signals the status of the slave in the EtherCAT network:

LED	Meaning
off	Slave is in "Init" state
flashes uniformly	Slave is in "Pre-Operational" state
flashes sporadically	Slave is in "Safe-Operational" state
lit	Slave is in "Operational" state

Description of the EtherCAT slave states

4.2.2.3 Cables

For connecting EtherCAT devices only shielded Ethernet cables that meet the requirements of at least category 5 (CAT5) according to EN 50173 or ISO/IEC 11801 should be used.

EtherCAT uses four wires for signal transmission.

Thanks to automatic line detection ("Auto MDI-X"), both symmetrical (1:1) or cross-over cables can be used between Beckhoff EtherCAT.

Detailed recommendations for the cabling of EtherCAT devices

4.2.3 Supply voltages

⚠ WARNING

Power supply from SELV / PELV power supply unit!

SELV / PELV circuits (safety extra-low voltage / protective extra-low voltage) according to IEC 61010-2-201 must be used to supply this device.

Notes:

- SELV / PELV circuits may give rise to further requirements from standards such as IEC 60204-1 et al, for example with regard to cable spacing and insulation.
- A SELV supply provides safe electrical isolation and limitation of the voltage without a connection to the protective conductor, a PELV supply also requires a safe connection to the protective conductor.

⚠ CAUTION

Observe the UL requirements

- When operating under UL conditions, observe the warnings in the chapter [UL Requirements](#) [► 90].

The EtherCAT Box has one input for two supply voltages:

- **Control voltage U_s**
The following sub-functions are supplied from the control voltage U_s :
 - the fieldbus
 - the processor logic
 - typically the inputs and the sensors if the EtherCAT Box has inputs.
- **Peripheral voltage U_p**
For EtherCAT Box modules with digital outputs the digital outputs are typically supplied from the peripheral voltage U_p . U_p can be supplied separately. If U_p is switched off, the fieldbus function, the function of the inputs and the supply of the sensors are maintained.

The exact assignment of U_s and U_p can be found in the pin assignment of the I/O connections.

Redirection of the supply voltages

The power IN and OUT connections are bridged in the module. Hence, the supply voltages U_s and U_p can be passed from EtherCAT Box to EtherCAT Box in a simple manner.

NOTICE

Note the maximum current!

Ensure that the permitted current for the connectors is not exceeded when routing the supply voltages U_s and U_p :

M8 connector: max. 4 A
7/8" connector: max 16 A



NOTICE

Unintentional cancellation of the electrical isolation possible

In some types of EtherCAT Box modules the ground potentials GND_s and GND_p are connected.

- If several EtherCAT Box modules are supplied with the same electrically isolated voltages, check whether there is an EtherCAT Box among them in which the ground potentials are connected.

4.2.3.1 Connectors

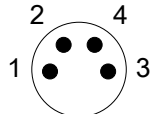
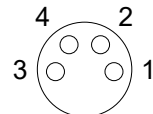
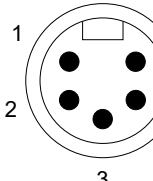
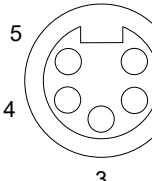
M8 connector		7/8" connector	
			
 <p>Plug Input</p>	 <p>Socket Forwarding</p>	 <p>Plug Feed-in</p>	 <p>Socket Forwarding</p>

Function	M8	7/8"	Description	Core color ¹⁾
U _s	1	4	Control voltage	Brown
U _p	2	5	Peripheral voltage	White
GND _s	3	2	GND to U _s	Blue
GND _p	4	1	GND to U _p	Black
FE	-	3	Functional earth	Grey

¹⁾ The core colors apply to cables of the type: Beckhoff ZK2020-xxxx-xxxx

4.2.3.2 Status LEDs



Fig. 7: Status LEDs for the supply voltages

LED	Display	Meaning
U _s (control voltage)	off	U _s not present.
	green illuminated	U _s present.
	red illuminated	Error. ¹⁾
U _p (peripheral voltage)	off	U _p not present.
	green illuminated	U _p present.
	red illuminated	Error. ¹⁾

¹⁾ Overload of the sensor supply/auxiliary voltage output at the signal interfaces.
 You can find out whether the sensor supply/auxiliary voltage is derived from U_s or from U_p from the assignment of the signal interfaces.

4.2.3.3 Conductor losses

Take into account the voltage drop on the supply line when planning a system. Avoid the voltage drop being so high that the supply voltage at the box lies below the minimum nominal voltage. Variations in the voltage of the power supply unit must also be taken into account.

Voltage drop on cables with M8 connectors

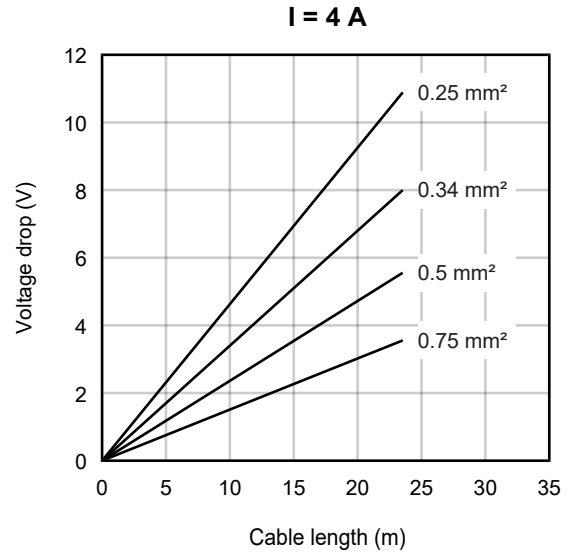
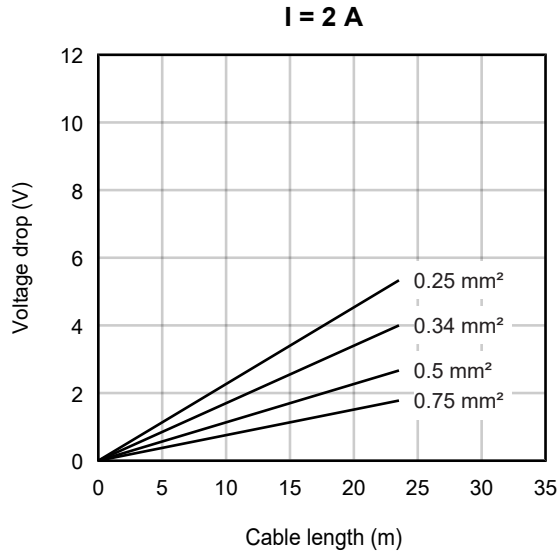

Voltage drop on cables with 7/8" connectors

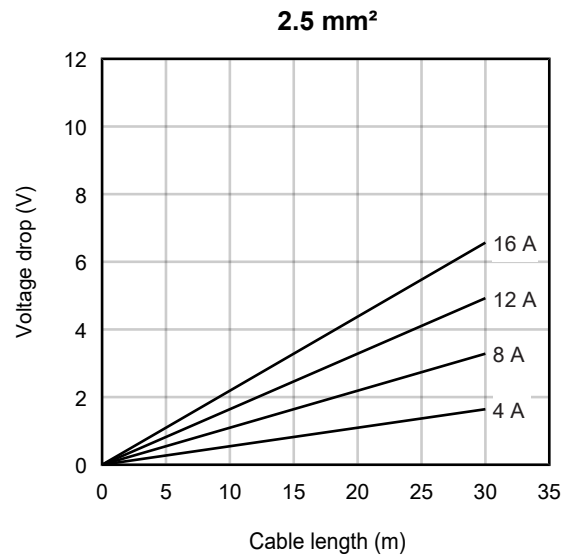
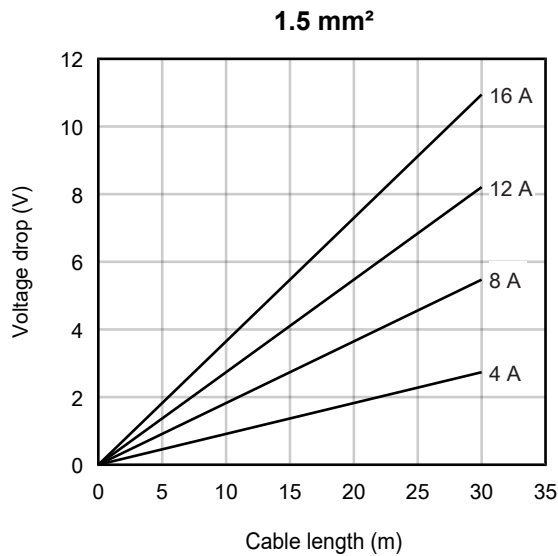

4.2.4 Digital inputs and digital outputs

4.2.4.1 EP2308-0001, EP2318-0001, EP2328-0001

Digital inputs

M8 sockets 0...3

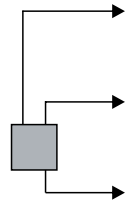
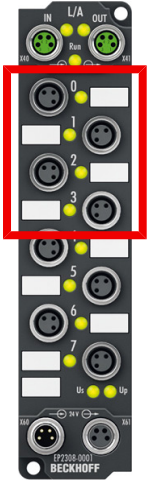

3-wire

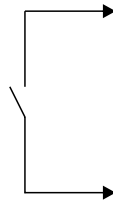

2-wire

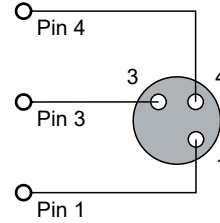

1 | +24 V U_s
3 | GND
4 | Input

Digital outputs

M8 sockets 4...7

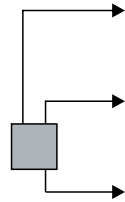
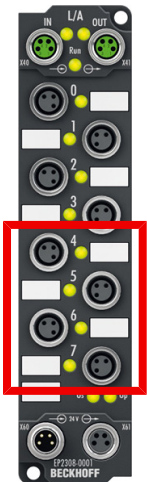

3-wire

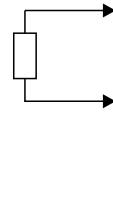

2-wire

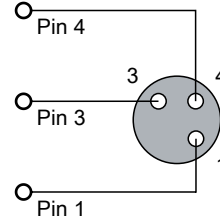

1 | +24 V U_s
3 | GND
4 | Output

4.2.4.2 EP2308-0002, EP2318-0002, EP2328-0002

Digital inputs

M12 sockets 0...3

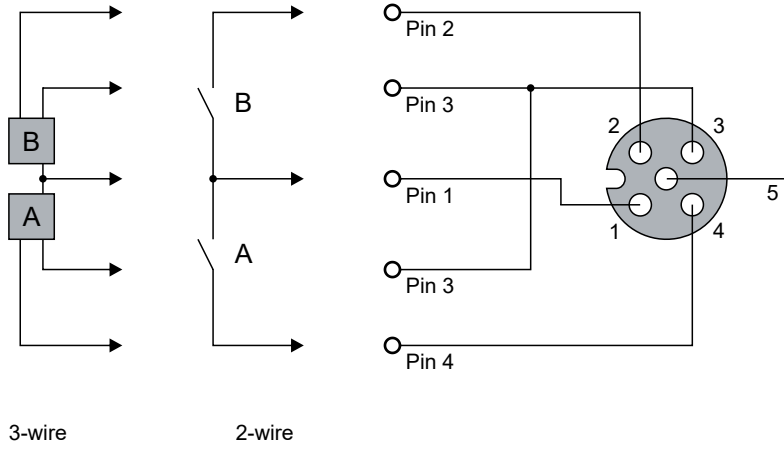
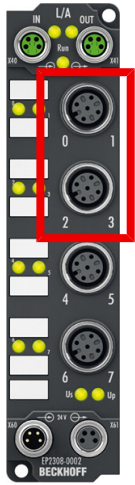

- 1 | +24 V U_S
- 2 | Input B
- 3 | GND
- 4 | Input A
- 5 | n.c.

Digital outputs

M12 sockets 4...7

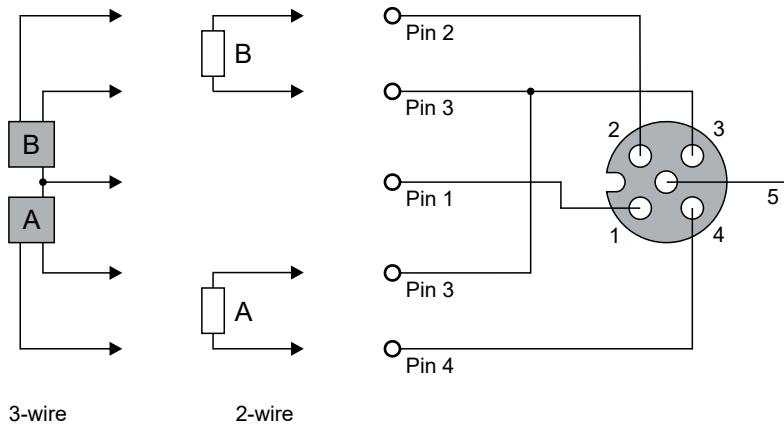
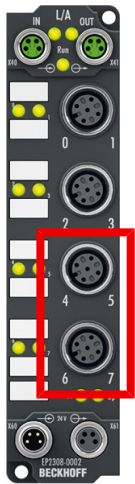

- 1 | +24 V U_S
- 2 | Output B
- 3 | GND
- 4 | Output A
- 5 | n.c.

4.2.4.3 EP2316-0003

Digital inputs

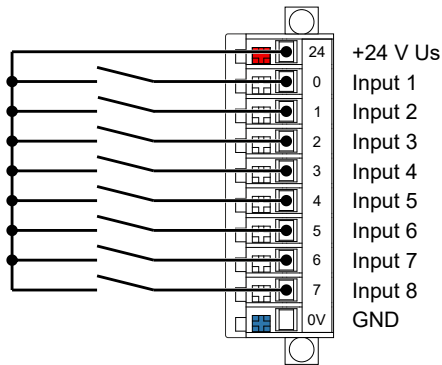
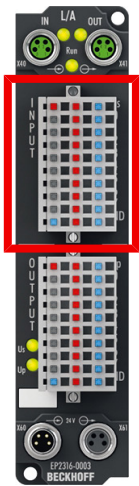

1-wire
(ZS2001-0001 / ZS2001-0002)

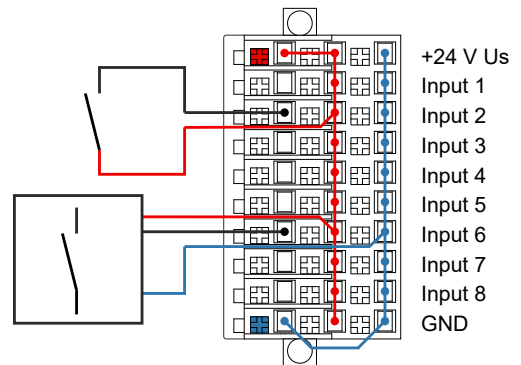

2-wire and 3-wire
(ZS2001-0004)

Digital outputs

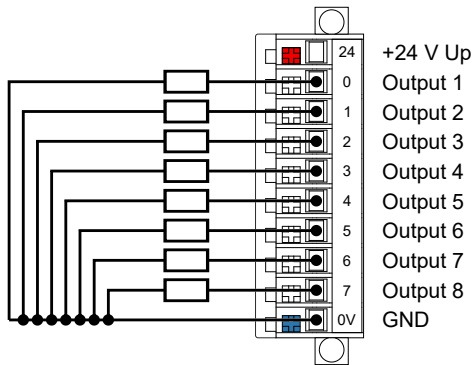
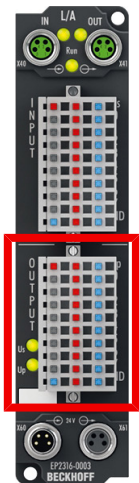

1-wire
(ZS2001-0001 / ZS2001-0002)

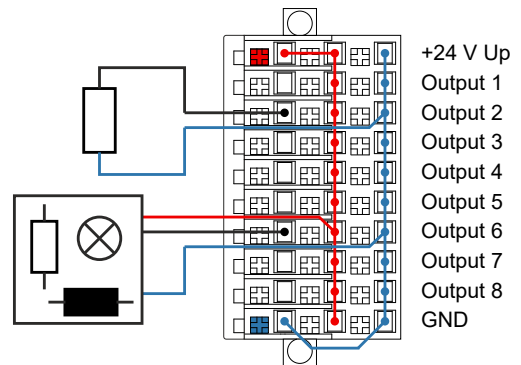

2-wire and 3-wire
(ZS2001-0004)

4.2.4.4 EP2316-0008

D-sub socket, 25-pin

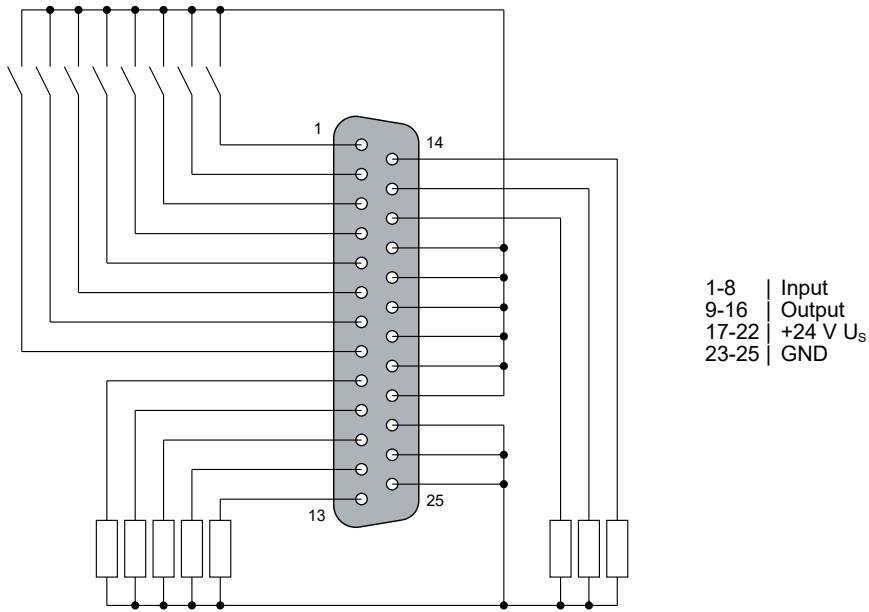

4.2.4.5 EP2338-0001, EP2338-1001

Each channel can be operated either as a digital input or as a digital output.

Operation as digital input

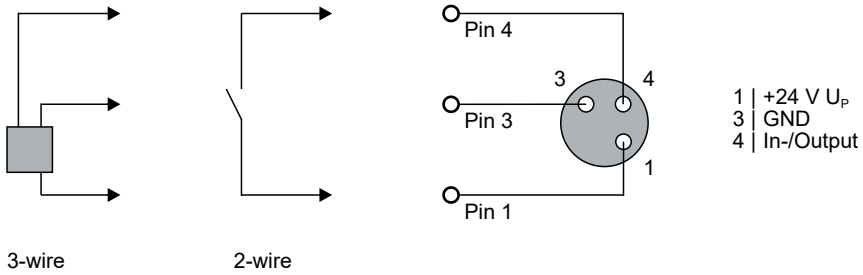

Operation as digital output

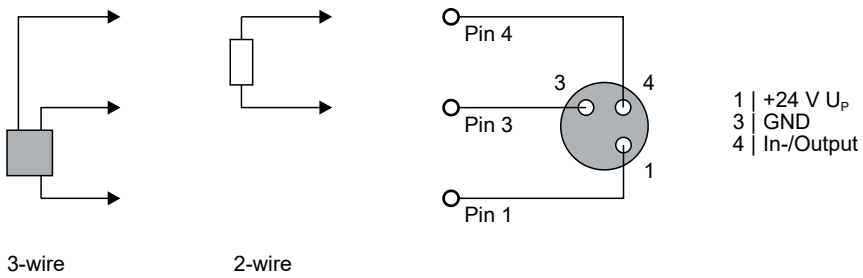

4.2.4.6 EP2338-0002, EP2338-1002

Each channel can be operated either as a digital input or as a digital output.

Operation as digital input

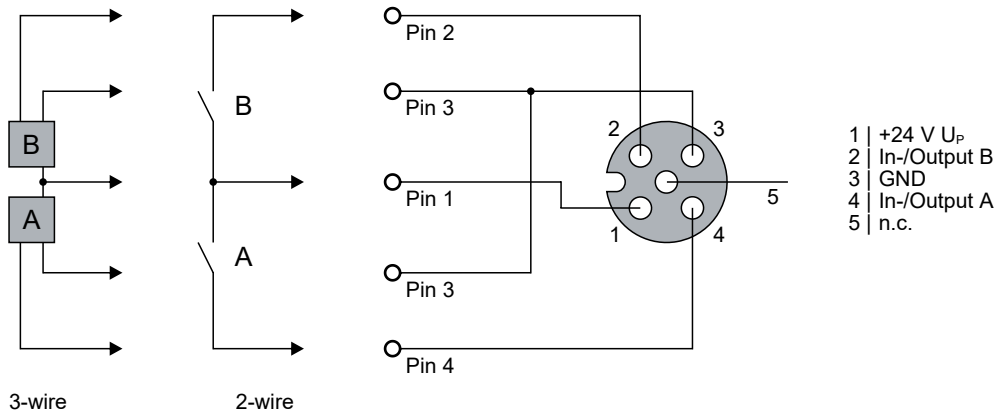

Operation as digital output

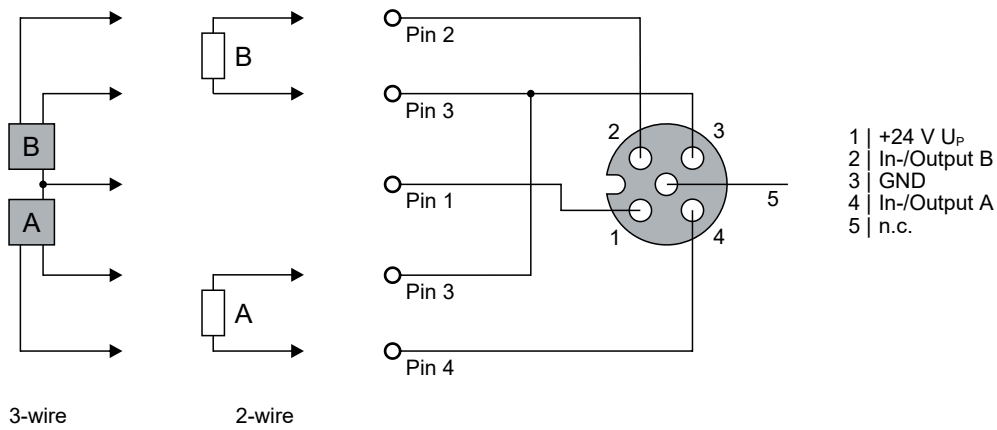

4.2.4.7 EP2338-2002

Each channel can be operated either as a digital input or as a digital output.

Operation as digital input

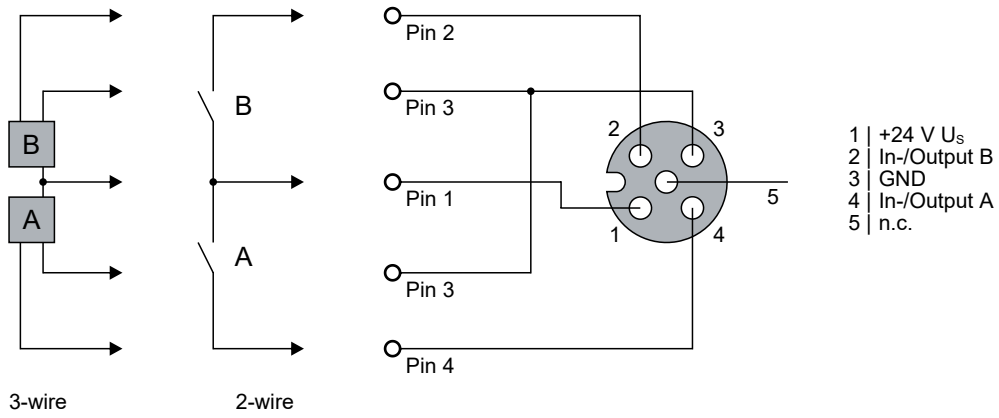

Operation as digital output

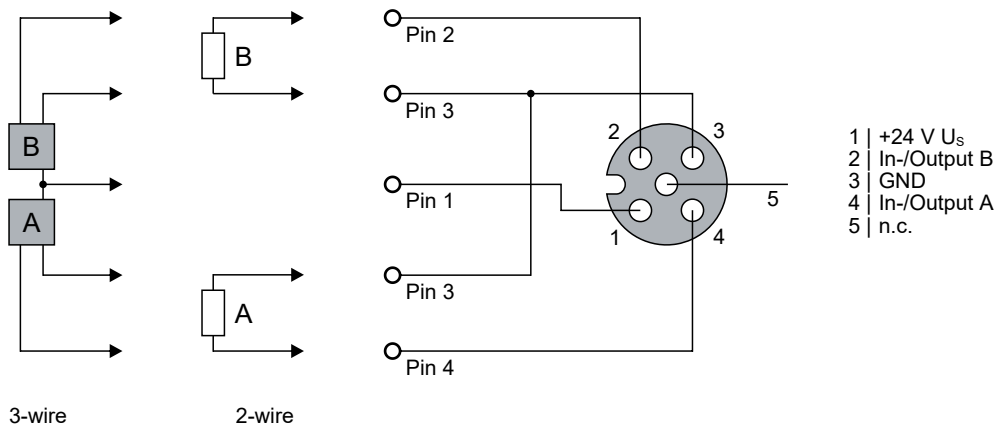

4.2.4.8 EP2339-0003

Each channel can be operated either as a digital input or as a digital output.

Operation as digital input

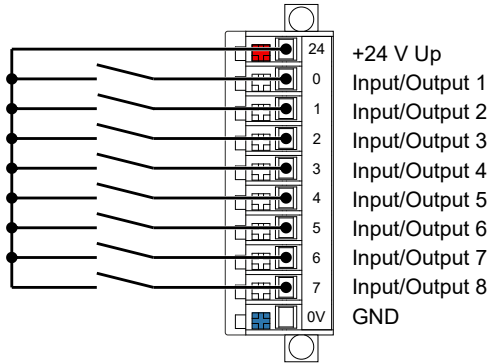

1-wire
(ZS2001-0001 / ZS2001-0002)

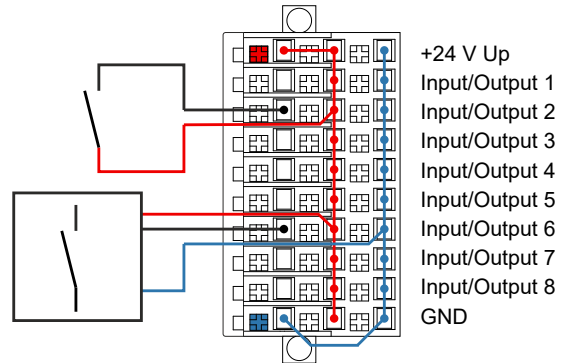

2-wire and 3-wire
(ZS2001-0004)

Operation as digital output

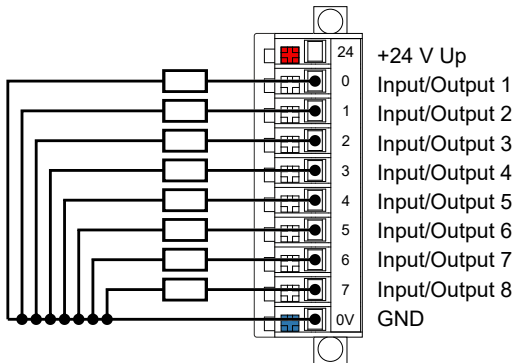

1-wire
(ZS2001-0001 / ZS2001-0002)

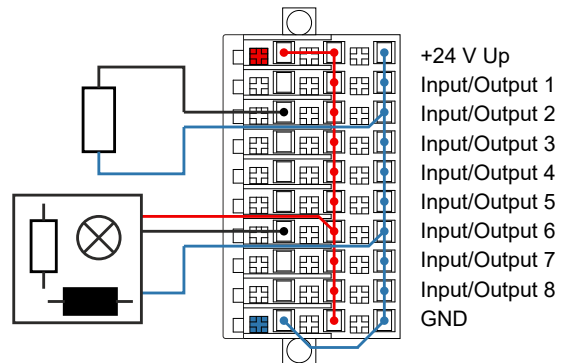

2-wire and 3-wire
(ZS2001-0004)

4.2.4.9 EP2339-0021, EP2349-0021

Each channel can be operated either as a digital input or as a digital output.

Operation as digital input

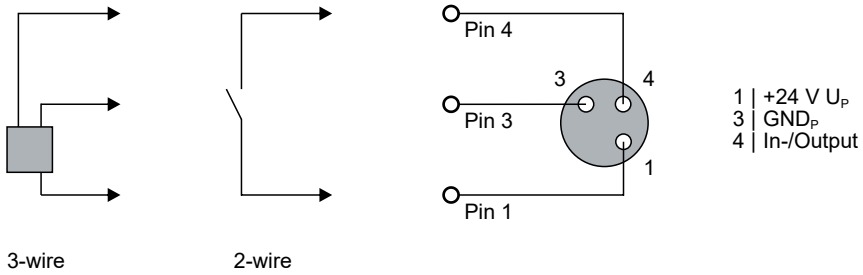

Operation as digital output

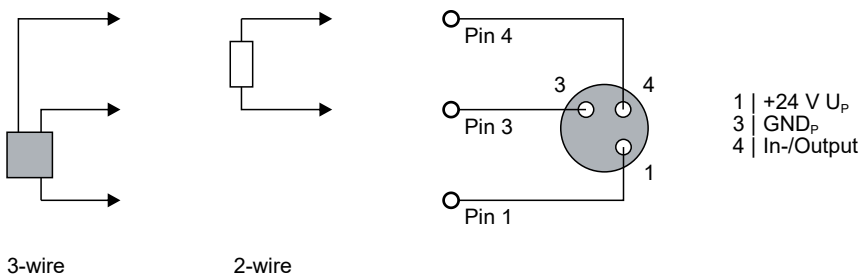

4.2.4.10 EP2339-0022, EP2349-0022

Each channel can be operated either as a digital input or as a digital output.

Operation as digital input

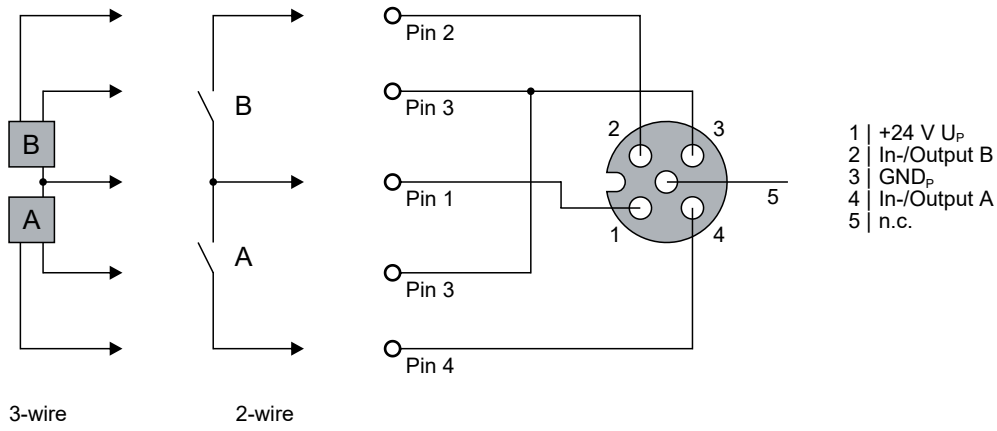

Operation as digital output

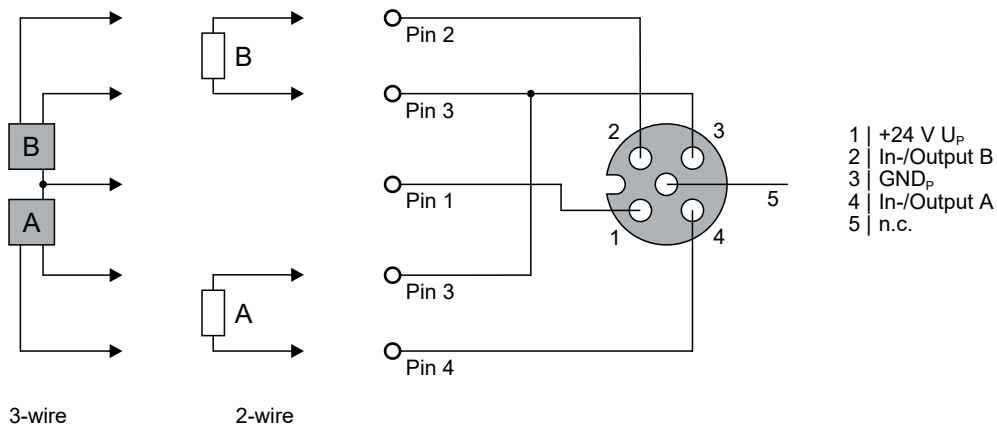

4.2.4.11 EP2339-0042

Each channel can be operated either as a digital input or as a digital output.

Operation as digital input

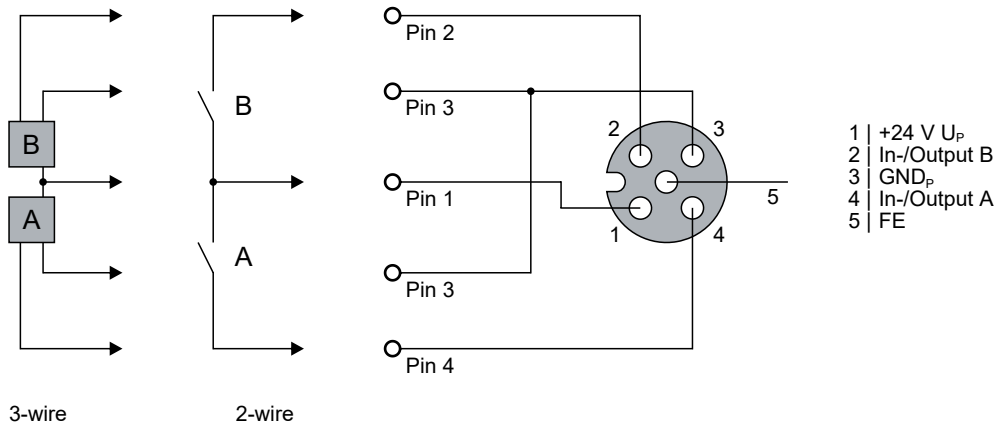

Operation as digital output

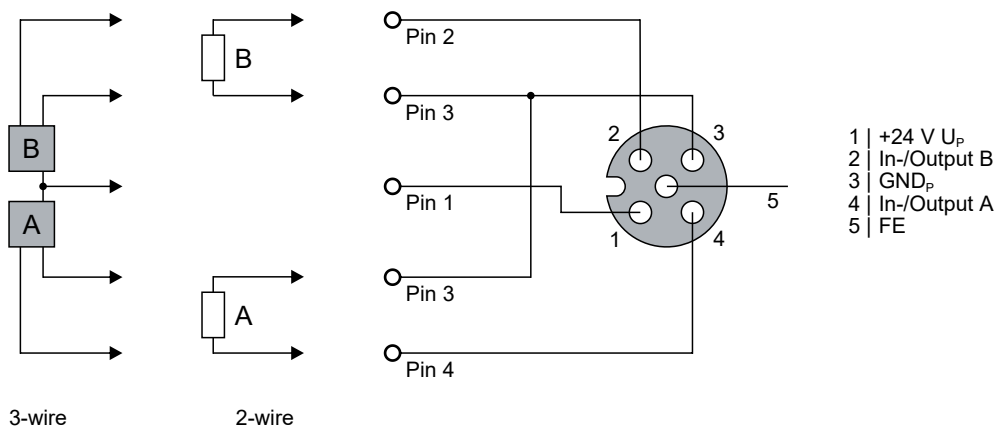

4.2.4.12 EP2339-0121

Each channel can be operated either as a digital input or as a digital output.

Operation as digital input, ground switching

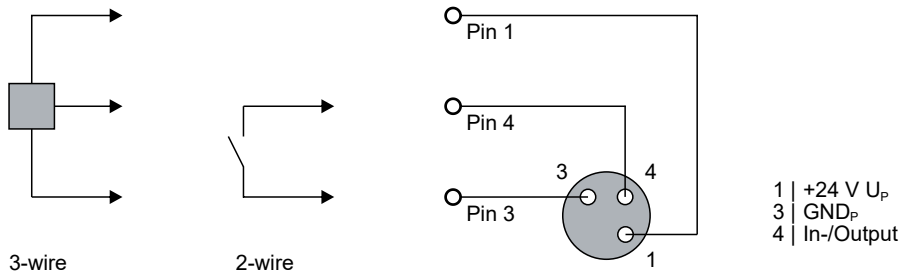

Operation as digital output, ground switching

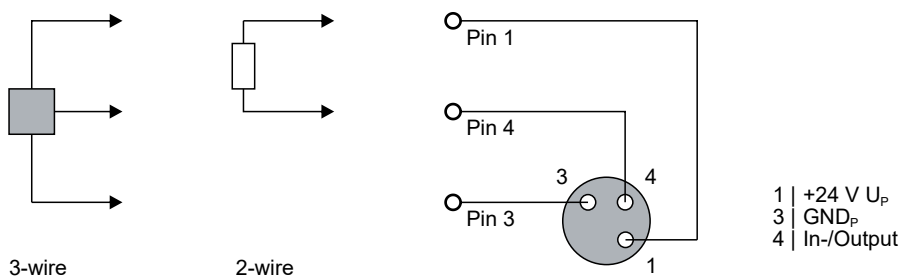

4.3 UL Requirements

The installation of the EtherCAT Box Modules certified by UL has to meet the following requirements.

Supply voltage

⚠ CAUTION

CAUTION!

This UL requirements are valid for all supply voltages of all marked EtherCAT Box Modules!
For the compliance of the UL requirements the EtherCAT Box Modules should only be supplied

- by a 24 V_{DC} supply voltage, supplied by an isolating source and protected by means of a fuse (in accordance with UL248), rated maximum 4 Amp, or
- by a 24 V_{DC} power source, that has to satisfy *NEC class 2*.
A *NEC class 2* power supply shall not be connected in series or parallel with another (class 2) power source!

⚠ CAUTION

CAUTION!

To meet the UL requirements, the EtherCAT Box Modules must not be connected to unlimited power sources!

Networks

⚠ CAUTION

CAUTION!

To meet the UL requirements, EtherCAT Box Modules must not be connected to telecommunication networks!

Ambient temperature range

⚠ CAUTION

CAUTION!

To meet the UL requirements, EtherCAT Box Modules has to be operated only at an ambient temperature range of -25 °C to +55 °C!

Marking for UL

All EtherCAT Box Modules certified by UL (Underwriters Laboratories) are marked with the following label.



Fig. 8: UL label

4.4 ATEX notes

4.4.1 ATEX - Special conditions

⚠ WARNING

Observe the special conditions for the intended use of EtherCAT Box modules in potentially explosive areas – directive 94/9/EU.

- The certified components are to be installed with a BG2000-0000 or BG2000-0010 protection enclosure [► 92] that guarantees a protection against mechanical hazards!
- If the temperatures during rated operation are higher than 70°C at the feed-in points of cables, lines or pipes, or higher than 80°C at the wire branching points, then cables must be selected whose temperature data correspond to the actual measured temperature values!
- Observe the permissible ambient temperature range of 0 to 55°C for the use of EtherCAT Box modules in potentially explosive areas!
- Measures must be taken to protect against the rated operating voltage being exceeded by more than 40% due to short-term interference voltages!
- The connections of the certified components may only be connected or disconnected if the supply voltage has been switched off or if a non-explosive atmosphere is ensured!

Standards

The fundamental health and safety requirements are fulfilled by compliance with the following standards:

- EN 60079-0: 2006
- EN 60079-15: 2005

Marking

The EtherCAT Box modules certified for potentially explosive areas bear the following marking:



II 3 G Ex nA II T4 DEKRA 11ATEX0080 X Ta: 0 - 55°C

or



II 3 G Ex nA nC IIC T4 DEKRA 11ATEX0080 X Ta: 0 - 55°C

Batch number (D number)

The EtherCAT Box modules bear a batch number (D number) that is structured as follows:

D: WW YY FF HH

WW - week of production (calendar week)

YY - year of production

FF - firmware version

HH - hardware version

Example with batch number 29 10 02 01:

29 - week of production 29

10 - year of production 2010

02 - firmware version 02

01 - hardware version 01

4.4.2 BG2000 - EtherCAT Box protection enclosures

⚠ WARNING

Risk of electric shock and damage of device!

Bring the EtherCAT system into a safe, powered down state before starting installation, disassembly or wiring of the modules!

ATEX

⚠ WARNING

Mount a protection enclosure!

To fulfill the special conditions according to ATEX [▶ 91], a BG2000-0000 or BG2000-0010 protection enclosure has to be mounted over the EtherCAT Box.

Installation

Put the cables for EtherCAT, power supply and sensors/actuators through the hole of the protection enclosure.

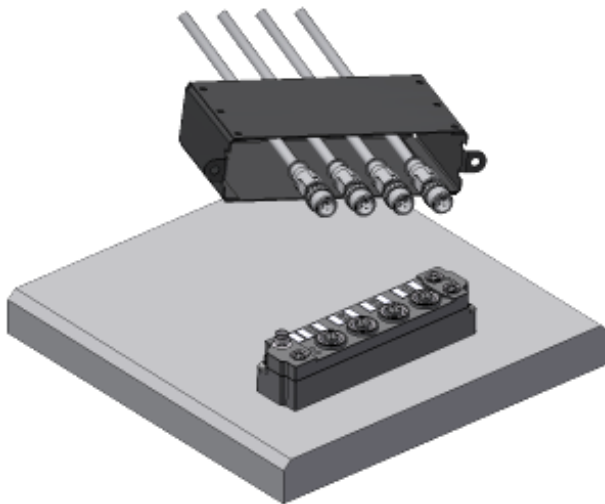

Fig. 9: BG2000 - putting the cables

Fix the wires for EtherCAT, power supply and sensors/actuators to the EtherCAT Box.

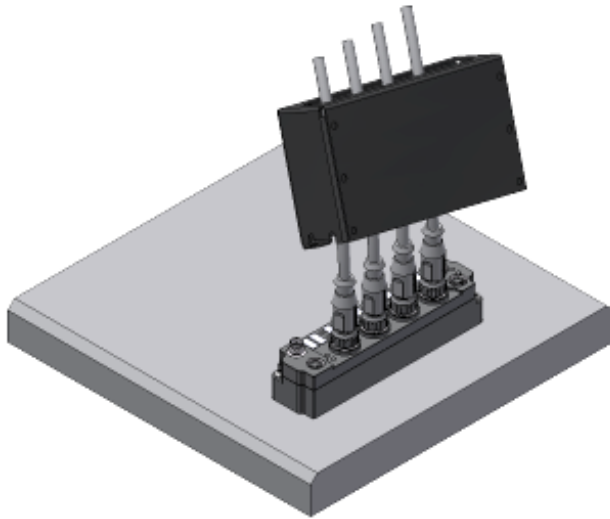

Fig. 10: BG2000 - fixing the cables

Mount the protection enclosure over the EtherCAT Box.

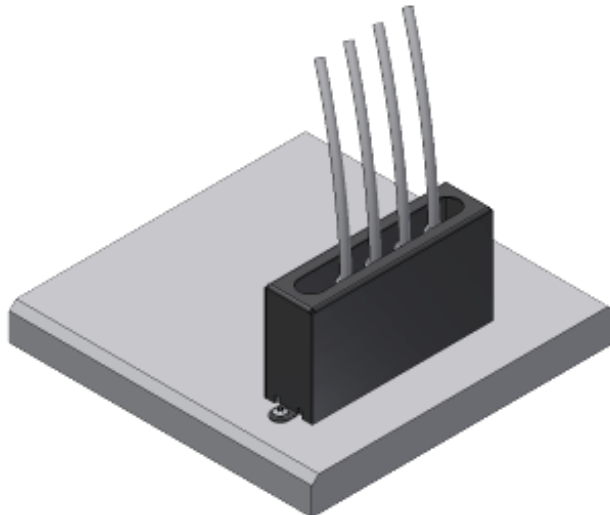

Fig. 11: BG2000 - mounting the protection enclosure

4.4.3 ATEX Documentation



Notes about operation of EtherCAT Box Modules (EPxxxx-xxxx) in potentially explosive areas (ATEX)

Pay also attention to the continuative documentation Notes about operation of EtherCAT Box Modules (EPxxxx-xxxx) in potentially explosive areas (ATEX) that is available in the download area of the Beckhoff homepage <http://www.beckhoff.com>!

4.5 Disposal



Products marked with a crossed-out wheeled bin shall not be discarded with the normal waste stream. The device is considered as waste electrical and electronic equipment. The national regulations for the disposal of waste electrical and electronic equipment must be observed.

5 Commissioning and configuration

5.1 Integrating into a TwinCAT project

The procedure for integration in a TwinCAT project is described in these [Quick start guide](#).

5.2 Switching inductive loads

When switching off inductive loads, high induction voltages result from interrupting the current too quickly. These are limited by an integrated free-wheeling diode. Since the current reduces only slowly, a delayed switch-off can occur in many control applications. For example, a valve remains open for many milliseconds. Switch-off times are realized that correspond, for instance, to the switch-on time of the coil.

● Protection against high induction voltages

i To protect against voltage peaks such as can occur when switching inductive loads, we recommend to provide suitable protective circuits (e.g. with the free-wheeling diode, RC combination or varistor) directly at the actuator.

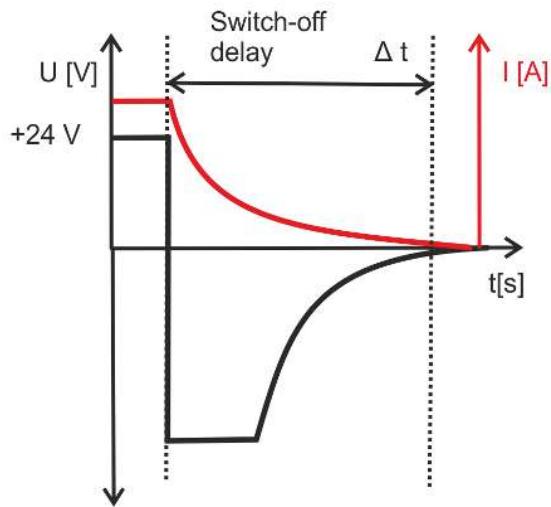

Fig. 12: Switch-off of inductive loads

5.3 Behavior of the outputs in case of a fault (EP2316 only)

EtherCAT Box Modules of the type EP2316 have diagnostic functions. They can detect faults and automatically react to them. The following chapters describe the configuration of the behavior in case of various types of fault.

5.3.1 Behavior in case of network failure

You can use bit 8000:0n (Safe State Active) to specify whether channel n should assume a certain value (Safe State Value) when data transmission is interrupted.

With bit 8001:0n (Safe State Value) you define this value for channel n.

● Safe State Value during network start-up

i The network transmits output process data only in the network states Save-Operational (SAFE-OP) and Operational (OP). Also at the network states INIT, Pre-Operational (PRE-OP) and BOOT passed through during network start-up no output process data is transmitted. If Safe State is activated for an output, this output also adopts the specified value during network start-up.

8000:0 - DIG Safe state active Ch.1

● Observe the maximum short-circuit current!

i When dimensioning the power supply unit and choosing the fuses, observe that the short-circuit current is approximately 1.7 A.

Index	Name	Flags	Value	Unit
7000:0	DIG Outputs Ch.1	RO	> 8 <	
8000:0	DIG Safe state active Ch.1	RW	> 8 <	
8000:01	Output 1	RW	TRUE	
8000:02	Output 2	RW	TRUE	
8000:03	Output 3	RW	TRUE	
8000:04	Output 4	RW	TRUE	
8000:05	Output 5	RW	TRUE	
8000:06	Output 6	RW	TRUE	
8000:07	Output 7	RW	TRUE	
8000:08	Output 8	RW	TRUE	
8001:0	DIG Safe state value Ch.1	RW	> 8 <	
8001:01	Output 1	RW	FALSE	
8001:02	Output 2	RW	FALSE	
8001:03	Output 3	RW	FALSE	
8001:04	Output 4	RW	FALSE	
8001:05	Output 5	RW	FALSE	
8001:06	Output 6	RW	FALSE	
8001:07	Output 7	RW	FALSE	
8001:08	Output 8	RW	FALSE	
F000:0	Modular device profile	RO	> 2 <	
F008	Code word	RW	0x00000000 (0)	

8000:01 to 8000:08 - DIG Safe state active Ch.1, Output 1 to Output 8 (default: TRUE)

Specifies whether or not the outputs should adopt a safe state in the case of a network failure.

Value	Meaning
FALSE	Safe state disabled
TRUE	Safe state enabled

8001:01 to 8001:08 - DIG Safe state value Ch.1, Output 1 to Output 8 (default: FALSE)

Specifies what the safe state is.

Value	Meaning
FALSE	Output switched off
TRUE	Output switched on

5.3.2 Behavior in case of short circuit

You can set the behavior of the outputs in case of short circuit in the CoE object F800 "DO Settings".

F800:0 - DO Settings (Safe State Value)

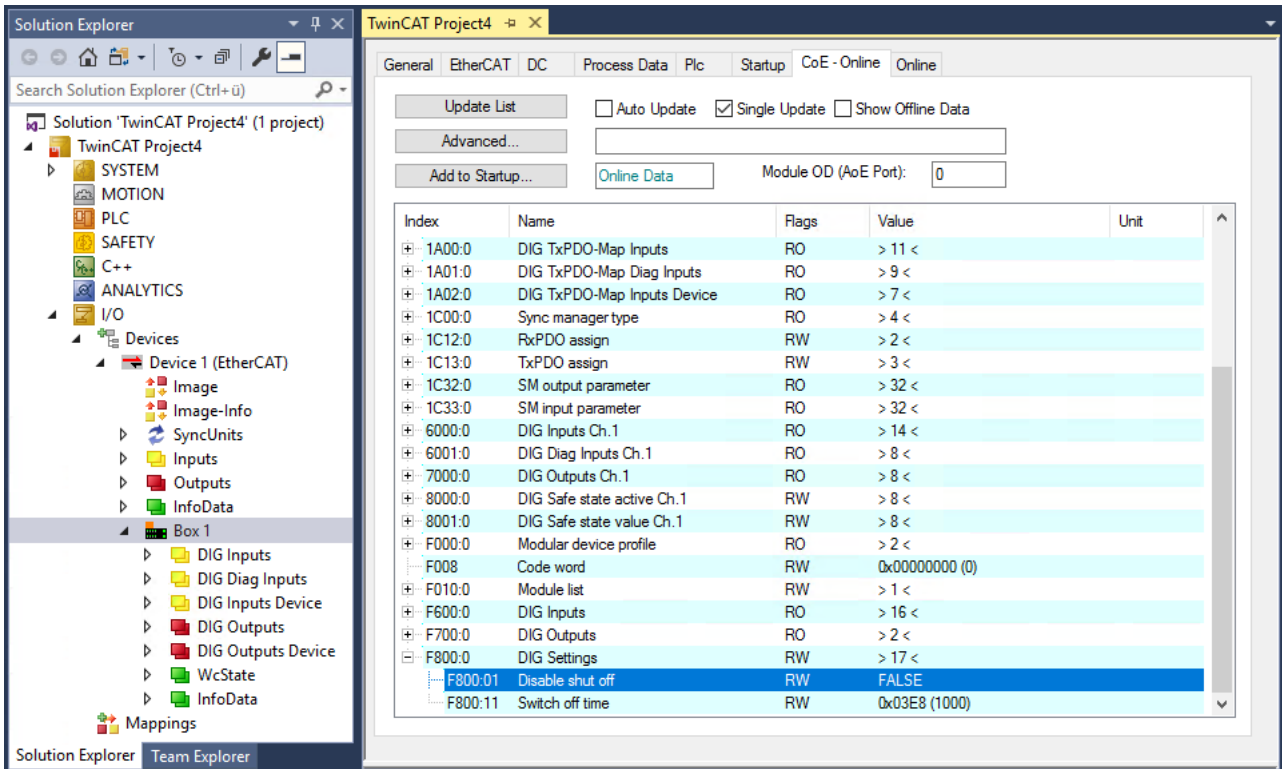

Table 1: F800:01 - Disable shut off (default: FALSE)

Value	Meaning
FALSE	In the event of a short circuit at one output, all outputs of the module are switched off. This disabling can be removed through the process data value <i>Reset Outputs</i> .
TRUE	In the event of a short circuit at an output, only this output of the module is switched off. After rectifying the short circuit, this output is automatically enabled again.

F800:11 - Switch off time (default: 0x03E8, 1000_{dec})

Here you can enter a time in milliseconds. During this time, the module checks whether the short circuit has been eliminated by switching itself on again.

Default = 1000 ms (depending on module type and internal cycle time). Errors are only displayed after this time.

5.3.3 Behavior in case of lack of supply voltage

The digital outputs are supplied from the supply voltage U_p . If the supply voltage U_p is not present, the digital outputs cannot output a high level.

If an output is set and does not output a high level, this is detected as a fault. On expiry of the fault reaction time, the fault is reported in the process data:

- The "Diag Input x " bit of the output is set to "1".
- The "Error Channel y " bit of the channel to which the output belongs is set to "1".

In the factory setting, all outputs of a channel in which a fault has occurred are disabled. The outputs also remain disabled when U_p is switched on again.

Re-enabling outputs

There are two ways to re-enable disabled outputs:

- Manual: Apply a positive edge to the variable "Reset outputs".

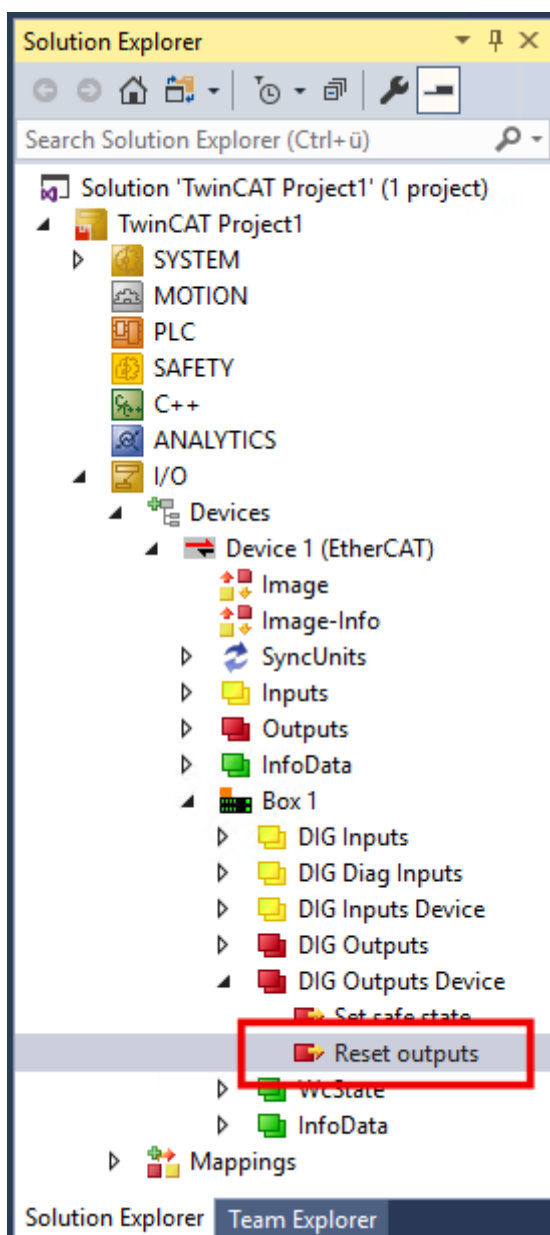

- Automatic: Set the parameter F800:01 to TRUE. All outputs will then be re-enabled as soon as U_p is switched on.

Note: F800:01 also influences the [behavior in case of short circuit](#) [▶ 99].

5.4 Restore the delivery state

You can restore the delivery state of the backup objects as follows:

1. Ensure that TwinCAT is running in Config mode.
2. In CoE object 1011:0 "Restore default parameters" select parameter 1011:01 "Subindex 001".



3. Double-click on "Subindex 001".
⇒ The "Set Value Dialog" dialog box opens.
4. Enter the value 1684107116 in the "Dec" field.
Alternatively: enter the value 0x64616F6C in the "Hex" field.

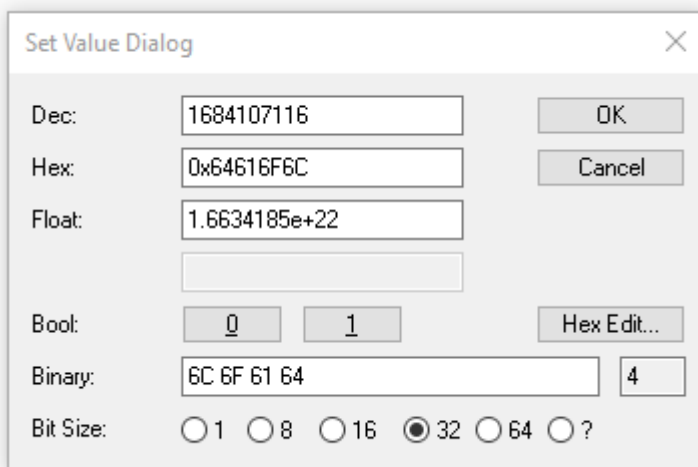

5. Confirm with "OK".
⇒ All backup objects are reset to the delivery state.

i Alternative restore value

With some older modules the backup objects can be changed with an alternative restore value:

Decimal value: 1819238756

Hexadecimal value: 0x6C6F6164

An incorrect entry for the restore value has no effect.

5.5 Decommissioning

⚠ WARNING**Risk of electric shock!**

Bring the bus system into a safe, de-energized state before starting disassembly of the devices!

6 Appendix

6.1 General operating conditions

Protection rating according to IP code

The degrees of protection are defined and divided into different classes in the IEC 60529 standard (EN 60529). Degrees of protection are designated by the letters "IP" and two numerals: **IPxy**

- Numeral x: Dust protection and contact protection
- Numeral y: Protection against water

x	Meaning
0	Not protected
1	Protected against access to dangerous parts with the back of the hand. Protected against solid foreign objects of 50 mm Ø
2	Protected against access to dangerous parts with a finger. Protected against solid foreign objects of 12.5 mm Ø
3	Protected against access to dangerous parts with a tool. Protected against solid foreign objects of 2.5 mm Ø
4	Protected against access to dangerous parts with a wire. Protected against solid foreign objects of 1 mm Ø
5	Protection against access to dangerous parts with a wire. Dust-protected. Ingress of dust is not prevented completely, although the quantity of dust able to penetrate is limited to such an extent that the proper function of the device and safety are not impaired
6	Protection against access to dangerous parts with a wire. Dust-tight. No ingress of dust

y	Meaning
0	Not protected
1	Protection against vertically falling water drops
2	Protection against vertically falling water drops when enclosure tilted up to 15°
3	Protection against spraying water. Water sprayed at an angle of up to 60° on either side of the vertical shall have no harmful effects
4	Protection against splashing water. Water splashed against the enclosure from any direction shall have no harmful effects
5	Protection against water jets.
6	Protection against powerful water jets.
7	Protected against the effects of temporary immersion in water. Ingress of water in quantities causing harmful effects shall not be possible when the enclosure is immersed in water at a depth of 1 m for 30 minutes

Chemical resistance

The resistance refers to the housing of the IP67 modules and the metal parts used. In the table below you will find some typical resistances.

Type	Resistance
Water vapor	unstable at temperatures > 100 °C
Sodium hydroxide solution (ph value > 12)	stable at room temperature unstable > 40 °C
Acetic acid	unstable
Argon (technically pure)	stable

Key

- resistant: Lifetime several months
- non inherently resistant: Lifetime several weeks
- not resistant: Lifetime several hours resp. early decomposition

6.2 Accessories

Mounting

Ordering information	Description	Link
ZS5300-0011	Mounting rail	Website

Cables

A complete overview of pre-assembled cables can be found on the Beckhoff website: [Link](#).

Ordering information	Description	Link
ZK1090-3xxx-xxxx	EtherCAT cable M8, green	Website
ZK1093-3xxx-xxxx	EtherCAT cable M8, yellow	Website
ZK1090-6xxx-xxxx	EtherCAT cable M12, green	Website
ZK2000-2xxx-xxxx	Sensor cable M8, 3-pin	Website
ZK2000-6xxx-xxxx	Sensor cable M12, 4-pin	Website
ZK2000-7xxx-0xxx	Sensor cable M12, 4-pin + shield	Website
ZK2020-3xxx-xxxx	Power cable M8, 4-pin	Website
ZK203x-xxxx-xxxx	Power cable 7/8", 5-pin	Website

Connector

Ordering information	Description	Link
ZS2001-000x	Female header with spring connection, IP20	Website
ZS2002-0111	D-sub connector, 25-pin	Website

Labeling material, protective caps

Ordering information	Description
ZS5000-0010	Protective cap for M8 sockets, IP67 (50 pieces)
ZS5000-0020	Protective cap for M12 sockets, IP67 (50 pcs.)
ZS5100-0000	Inscription labels, unprinted, 4 strips of 10
ZS5000-xxxx	Printed inscription labels on enquiry

Tools

Ordering information	Description
ZB8801-0000	Torque wrench for plugs, 0.4...1.0 Nm
ZB8801-0001	Torque cable key for M8 / wrench size 9 for ZB8801-0000
ZB8801-0002	Torque cable key for M12 / wrench size 13 for ZB8801-0000
ZB8801-0003	Torque cable key for M12 field assembly / wrench size 18 for ZB8801-0000



Further accessories

Further accessories can be found in the price list for fieldbus components from Beckhoff and online at <https://www.beckhoff.com>.

6.3 Version identification of EtherCAT devices

6.3.1 General notes on marking

Designation

A Beckhoff EtherCAT device has a 14-digit designation, made up of

- family key
- type
- version
- revision

Example	Family	Type	Version	Revision
EL3314-0000-0016	EL terminal 12 mm, non-pluggable connection level	3314 4-channel thermocouple terminal	0000 basic type	0016
ES3602-0010-0017	ES terminal 12 mm, pluggable connection level	3602 2-channel voltage measurement	0010 high-precision version	0017
CU2008-0000-0000	CU device	2008 8-port fast ethernet switch	0000 basic type	0000

Notes

- The elements mentioned above result in the **technical designation**. EL3314-0000-0016 is used in the example below.
- EL3314-0000 is the order identifier, in the case of “-0000” usually abbreviated to EL3314. “-0016” is the EtherCAT revision.
- The **order identifier** is made up of
 - family key (EL, EP, CU, ES, KL, CX, etc.)
 - type (3314)
 - version (-0000)
- The **revision** -0016 shows the technical progress, such as the extension of features with regard to the EtherCAT communication, and is managed by Beckhoff.
 In principle, a device with a higher revision can replace a device with a lower revision, unless specified otherwise, e.g. in the documentation.
 Associated and synonymous with each revision there is usually a description (ESI, EtherCAT Slave Information) in the form of an XML file, which is available for download from the Beckhoff web site.
 From 2014/01 the revision is shown on the outside of the IP20 terminals, see Fig. “EL2872 with revision 0022 and serial number 01200815”.
- The type, version and revision are read as decimal numbers, even if they are technically saved in hexadecimal.

6.3.2 Version identification of IP67 modules

The serial number/ data code for Beckhoff IO devices is usually the 8-digit number printed on the device or on a sticker. The serial number indicates the configuration in delivery state and therefore refers to a whole production batch, without distinguishing the individual modules of a batch.

Structure of the serial number: **KK YY FF HH**

KK - week of production (CW, calendar week)

YY - year of production

FF - firmware version

HH - hardware version

Example with serial number 12 06 3A 02:

12 - production week 12

06 - production year 2006

3A - firmware version 3A

02 - hardware version 02

Exceptions can occur in the **IP67 area**, where the following syntax can be used (see respective device documentation):

Syntax: D ww yy x y z u

D - prefix designation

ww - calendar week

yy - year

x - firmware version of the bus PCB

y - hardware version of the bus PCB

z - firmware version of the I/O PCB

u - hardware version of the I/O PCB

Example: D.22081501 calendar week 22 of the year 2008 firmware version of bus PCB: 1 hardware version of bus PCB: 5 firmware version of I/O PCB: 0 (no firmware necessary for this PCB) hardware version of I/O PCB: 1

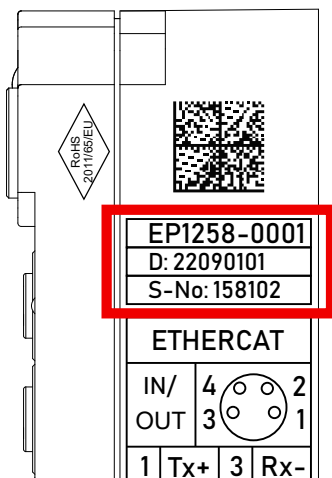

Fig. 13: EP1258-00001 IP67 EtherCAT Box with batch number/DateCode 22090101 and unique serial number 158102

6.3.3 Beckhoff Identification Code (BIC)

The Beckhoff Identification Code (BIC) is increasingly being applied to Beckhoff products to uniquely identify the product. The BIC is represented as a Data Matrix Code (DMC, code scheme ECC200), the content is based on the ANSI standard MH10.8.2-2016.

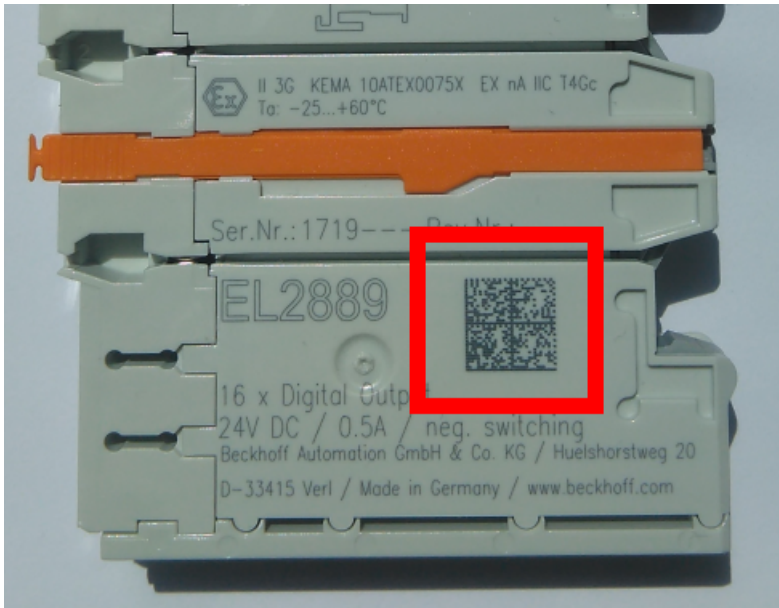

Fig. 14: BIC as data matrix code (DMC, code scheme ECC200)

The BIC will be introduced step by step across all product groups.

Depending on the product, it can be found in the following places:

- on the packaging unit
- directly on the product (if space suffices)
- on the packaging unit and the product

The BIC is machine-readable and contains information that can also be used by the customer for handling and product management.

Each piece of information can be uniquely identified using the so-called data identifier (ANSI MH10.8.2-2016). The data identifier is followed by a character string. Both together have a maximum length according to the table below. If the information is shorter, spaces are added to it.

Following information is possible, positions 1 to 4 are always present, the other according to need of production:

Position	Type of information	Explanation	Data identifier	Number of digits incl. data identifier	Example
1	Beckhoff order number	Beckhoff order number	1P	8	1P 072222
2	Beckhoff Traceability Number (BTN)	Unique serial number, see note below	SBTN	12	SBTN k4p562d7
3	Article description	Beckhoff article description, e.g. EL1008	1K	32	1KEL 1809
4	Quantity	Quantity in packaging unit, e.g. 1, 10, etc.	Q	6	Q1
5	Batch number	Optional: Year and week of production	2P	14	2P 401503180016
6	ID/serial number	Optional: Present-day serial number system, e.g. with safety products	51S	12	51S 678294
7	Variant number	Optional: Product variant number on the basis of standard products	30P	12	30P F971, 2*K183
...					

Further types of information and data identifiers are used by Beckhoff and serve internal processes.

Structure of the BIC

Example of composite information from positions 1 to 4 and with the above given example value on position 6. The data identifiers are highlighted in bold font:

1P072222**SBTN**k4p562d7**1KEL**1809 **Q1** **51S**678294

Accordingly as DMC:



Fig. 15: Example DMC **1P072222SBTN**k4p562d7**1KEL**1809 **Q1** **51S**678294

BTN

An important component of the BIC is the Beckhoff Traceability Number (BTN, position 2). The BTN is a unique serial number consisting of eight characters that will replace all other serial number systems at Beckhoff in the long term (e.g. batch designations on IO components, previous serial number range for safety products, etc.). The BTN will also be introduced step by step, so it may happen that the BTN is not yet coded in the BIC.

NOTICE

This information has been carefully prepared. However, the procedure described is constantly being further developed. We reserve the right to revise and change procedures and documentation at any time and without prior notice. No claims for changes can be made from the information, illustrations and descriptions in this documentation.

6.3.4 Electronic access to the BIC (eBIC)

Electronic BIC (eBIC)

The Beckhoff Identification Code (BIC) is applied to the outside of Beckhoff products in a visible place. If possible, it should also be electronically readable.

The interface that the product can be electronically addressed by is crucial for the electronic readout.

EtherCAT devices (IP20, IP67)

All Beckhoff EtherCAT devices have an ESI-EEPROM which contains the EtherCAT identity with the revision number. The EtherCAT slave information, also colloquially known as the ESI/XML configuration file for the EtherCAT master, is stored in it. See the corresponding chapter in the EtherCAT system manual ([Link](#)) for the relationships.

Beckhoff also stores the eBIC in the ESI-EEPROM. The eBIC was introduced into Beckhoff IO production (terminals, box modules) in 2020; as of 2023, implementation is largely complete.

The user can electronically access the eBIC (if present) as follows:

- With all EtherCAT devices, the EtherCAT master (TwinCAT) can read the eBIC from the ESI-EEPROM
 - From TwinCAT 3.1 build 4024.11, the eBIC can be displayed in the online view.
 - To do this, check the "Show Beckhoff Identification Code (BIC)" checkbox under EtherCAT → Advanced Settings → Diagnostics:

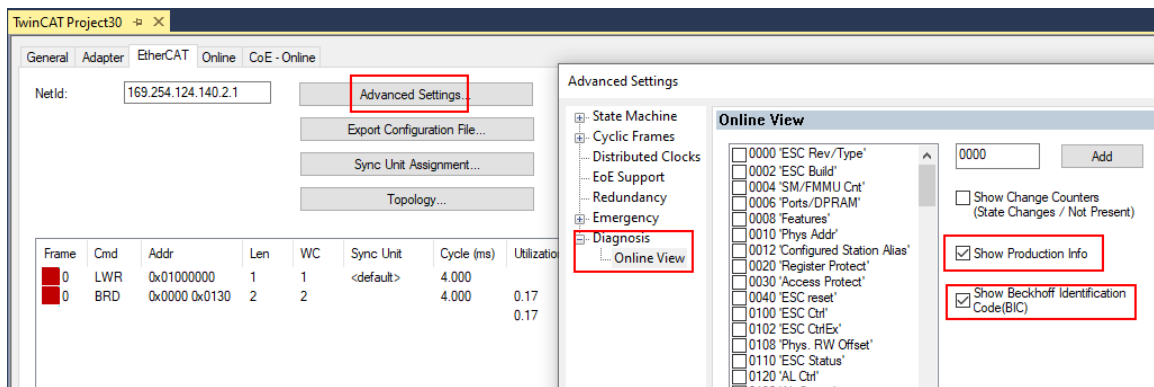

- The BTN and its contents are then displayed:

No	Addr	Name	State	CRC	Fw	Hw	Production Data	ItemNo	BTN	Description	Quantity	BatchNo	SerialNo
1	1001	Term 1 (EK1100)	OP	0,0	0	0	---						
2	1002	Term 2 (EL1018)	OP	0,0	0	0	2020 KW36 Fr	072222	k4p562d7	EL1809	1		678294
3	1003	Term 3 (EL3204)	OP	0,0	7	6	2012 KW24 Sa						
4	1004	Term 4 (EL2004)	OP	0,0	0	0	---	072223	k4p562d7	EL2004	1		678295
5	1005	Term 5 (EL1008)	OP	0,0	0	0	---						
6	1006	Term 6 (EL2008)	OP	0,0	0	12	2014 KW14 Mo						
7	1007	Term 7 (EK1110)	OP	0	1	8	2012 KW25 Mo						

- Note: As shown in the figure, the production data HW version, FW version, and production date, which have been programmed since 2012, can also be displayed with "Show production info".
- Access from the PLC: From TwinCAT 3.1. build 4024.24, the functions *FB_EcReadBIC* and *FB_EcReadBTN* for reading into the PLC are available in the Tc2_EtherCAT library from v3.3.19.0.
- EtherCAT devices with a CoE directory may also have the object 0x10E2:01 to display their own eBIC, which can also be easily accessed by the PLC:

- The device must be in PREOP/SAFEOP/OP for access:

Index	Name	Flags	Value
1000	Device type	RO	0x015E1389 (22942601)
1008	Device name	RO	ELM3704-0000
1009	Hardware version	RO	00
100A	Software version	RO	01
100B	Bootloader version	RO	J0.1.27.0
1011:0	Restore default parameters	RO	> 1 <
1018:0	Identity	RO	> 4 <
10E2:0	Manufacturer-specific Identification C...	RO	> 1 <
10E2:01	Subindex 001	RO	1P158442SBTN0008jckp1KELM3704 Q1 2P482001000016
10F0:0	Backup parameter handling	RO	> 1 <
10F3:0	Diagnosis History	RO	> 21 <
10F8	Actual Time Stamp	RO	0x170bfb277e

- The object 0x10E2 will be preferentially introduced into stock products in the course of necessary firmware revision.
- From TwinCAT 3.1. build 4024.24, the functions *FB_EcCoEReadBIC* and *FB_EcCoEReadBTN* for reading into the PLC are available in the *Tc2_EtherCAT* library from v3.3.19.0
- The following auxiliary functions are available for processing the BIC/BTN data in the PLC in *Tc2_Uilities* as of TwinCAT 3.1 build 4024.24
 - *F_SplitBIC*: The function splits the Beckhoff Identification Code (BIC) *sBICValue* into its components using known identifiers and returns the recognized substrings in the *ST_SplittedBIC* structure as a return value
 - *BIC_TO_BTN*: The function extracts the BTN from the BIC and returns it as a return value
- Note: If there is further electronic processing, the BTN is to be handled as a string(8); the identifier "SBTN" is not part of the BTN.
- Technical background
The new BIC information is written as an additional category in the ESI-EEPROM during device production. The structure of the ESI content is largely dictated by the ETG specifications, therefore the additional vendor-specific content is stored using a category in accordance with the ETG.2010. ID 03 tells all EtherCAT masters that they may not overwrite these data in the event of an update or restore the data after an ESI update.
The structure follows the content of the BIC, see here. The EEPROM therefore requires approx. 50..200 bytes of memory.
- Special cases
 - If multiple hierarchically arranged ESCs are installed in a device, only the top-level ESC carries the eBIC information.
 - If multiple non-hierarchically arranged ESCs are installed in a device, all ESCs carry the eBIC information.
 - If the device consists of several sub-devices which each have their own identity, but only the top-level device is accessible via EtherCAT, the eBIC of the top-level device is located in the CoE object directory 0x10E2:01 and the eBICs of the sub-devices follow in 0x10E2:nn.

6.4 Support and Service

Beckhoff and their partners around the world offer comprehensive support and service, making available fast and competent assistance with all questions related to Beckhoff products and system solutions.

Beckhoff's branch offices and representatives

Please contact your Beckhoff branch office or representative for local support and service on Beckhoff products!

The addresses of Beckhoff's branch offices and representatives round the world can be found on her internet pages: www.beckhoff.com

You will also find further documentation for Beckhoff components there.

Support

The Beckhoff Support offers you comprehensive technical assistance, helping you not only with the application of individual Beckhoff products, but also with other, wide-ranging services:

- support
- design, programming and commissioning of complex automation systems
- and extensive training program for Beckhoff system components

Hotline: +49 5246 963 157
e-mail: support@beckhoff.com
web: www.beckhoff.com/support

Service

The Beckhoff Service Center supports you in all matters of after-sales service:

- on-site service
- repair service
- spare parts service
- hotline service

Hotline: +49 5246 963 460
e-mail: service@beckhoff.com
web: www.beckhoff.com/service

Headquarters Germany

Beckhoff Automation GmbH & Co. KG

Hülshorstweg 20
33415 Verl
Germany

Phone: +49 5246 963 0
e-mail: info@beckhoff.com
web: www.beckhoff.com

Trademark statements

Beckhoff®, TwinCAT®, TwinCAT/BSD®, TC/BSD®, EtherCAT®, EtherCAT G®, EtherCAT G10®, EtherCAT P®, Safety over EtherCAT®, TwinSAFE®, XFC®, XTS® and XPlanar® are registered trademarks of and licensed by Beckhoff Automation GmbH.

Beckhoff Automation GmbH & Co. KG
Hülshorstweg 20
33415 Verl
Germany
Phone: +49 5246 9630
info@beckhoff.com
www.beckhoff.com