

Documentation | EN

# SCL6xxx

Low power split-core transformers, 3-channel current interface, accuracy class 0.5, electronic nameplate, RJ45

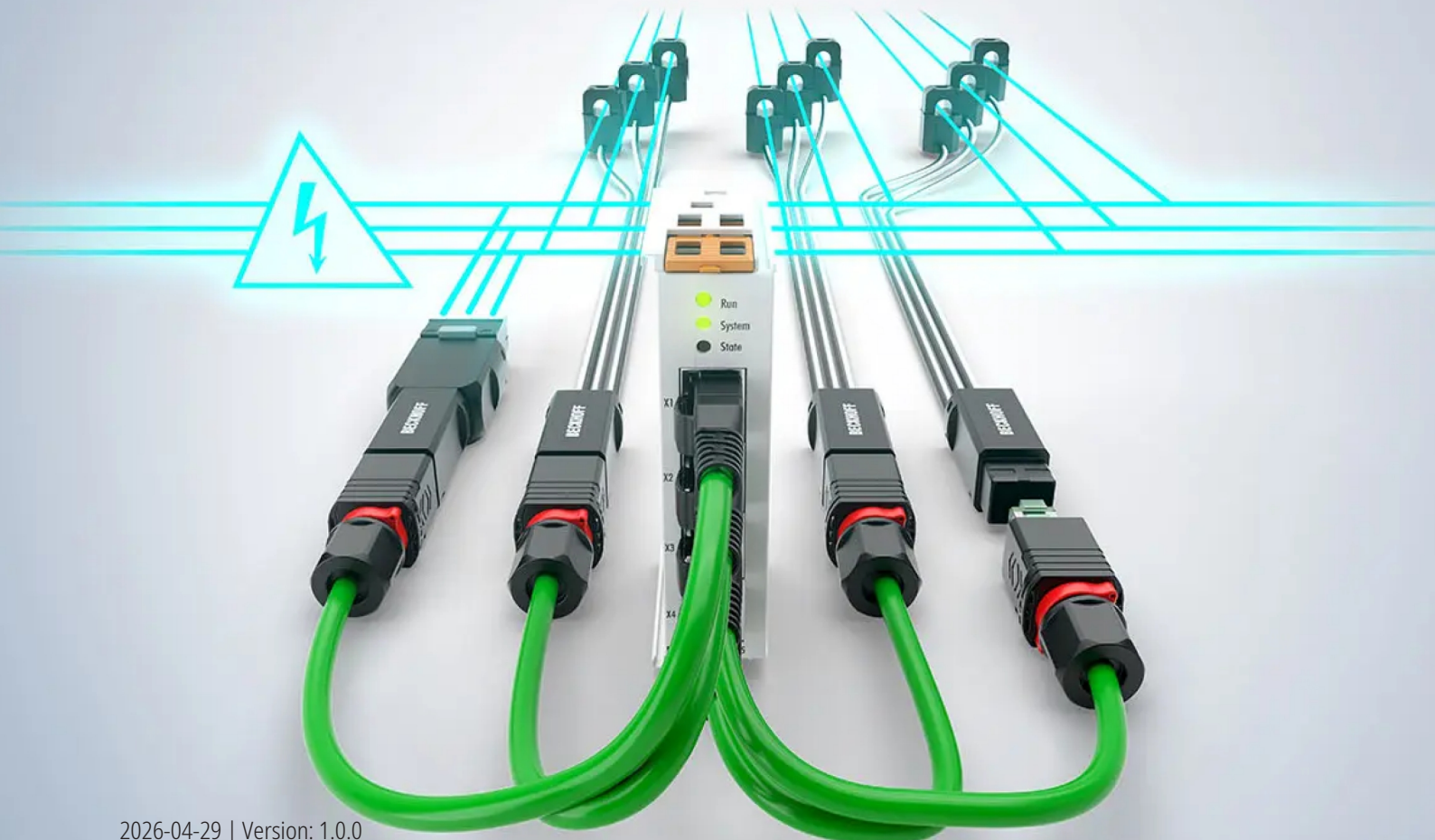



# Table of contents

<b>1 Foreword</b> .....	<b>5</b>
1.1 Product overview.....	5
1.2 Notes on the documentation .....	6
1.3 Safety instructions.....	7
1.4 Intended use .....	8
1.5 Safety instructions for current transformers .....	8
<b>2 SCL60xx - Product description</b> .....	<b>10</b>
2.1 SCL6023-0015 - Technical data .....	11
2.2 SCL6023-0030 - Technical data .....	12
2.3 SCL6023-0060 - Technical data .....	13
2.4 SCL6023-0075 - Technical data .....	14
2.5 Dimensions size 1 .....	15
<b>3 SCL61xx - Product description</b> .....	<b>16</b>
3.1 SCL6123-0020 - Technical data .....	17
3.2 SCL6123-0040 - Technical data .....	18
3.3 SCL6123-0060 - Technical data .....	19
3.4 Dimensions size 2 .....	20
<b>4 SCL62xx - Product description</b> .....	<b>21</b>
4.1 SCL6223-0010 - Technical data .....	22
4.2 SCL6223-0080 - Technical data .....	23
4.3 SCL6223-0100 - Technical data .....	24
4.4 Dimensions size 3.....	25
<b>5 SCL63xx - Product description</b> .....	<b>26</b>
5.1 SCL6323-0100 - Technical data .....	27
5.2 SCL6323-0200 - Technical data .....	28
5.3 SCL6323-0400 - Technical data .....	29
5.4 Dimensions size 4 .....	30
<b>6 Accessories</b> .....	<b>31</b>
<b>7 Basics current transformers</b> .....	<b>32</b>
7.1 Function and structure .....	32
7.2 Technical terms of current transformers .....	34
<b>8 Notes on the class accuracy of current transformers</b> .....	<b>35</b>
<b>9 Mounting and wiring</b> .....	<b>36</b>
<b>10 Commissioning</b> .....	<b>39</b>
10.1 Maintenance, inspection and troubleshooting.....	39
10.2 Note on operation without electronic nameplate.....	40
<b>11 Application example</b> .....	<b>41</b>
11.1 Power measurement at a machine .....	41
<b>12 Appendix</b> .....	<b>43</b>
12.1 Documentation issue status .....	43
12.2 Support and Service.....	44



# 1 Foreword

## 1.1 Product overview



Fig. 1: SCL6xxx - Low power split-core transformer, 3-channel current interface, in four sizes

### Low power split-core transformers, 3-channel current interface, accuracy class 0.5, electronic nameplate, RJ45

This documentation covers the following products:

#### **SCL60xx** [[▶ 10](#)] | size 1 (transformer opening 9.7 mm)

- [SCL6023-0015](#) [[▶ 11](#)] 15 A AC, accuracy class 0.5, electronic nameplate, RJ45
- [SCL6023-0030](#) [[▶ 12](#)] 30 A AC, accuracy class 0.5, electronic nameplate, RJ45
- [SCL6023-0060](#) [[▶ 13](#)] 60 A AC, accuracy class 0.5, electronic nameplate, RJ45
- [SCL6023-0075](#) [[▶ 14](#)] 75 A AC, accuracy class 0.5, electronic nameplate, RJ45

#### **SCL61xx** [[▶ 16](#)] | size 2 (transformer opening 6 mm)

- [SCL6123-0020](#) [[▶ 17](#)] 20 A AC, accuracy class 0.5, electronic nameplate, RJ45
- [SCL6123-0040](#) [[▶ 18](#)] 40 A AC, accuracy class 0.5, electronic nameplate, RJ45
- [SCL6123-0060](#) [[▶ 19](#)] 60 A AC, accuracy class 0.5, electronic nameplate, RJ45

#### **SCL62xx** [[▶ 21](#)] | size 3 (transformer opening 12 mm)

- [SCL6223-0010](#) [[▶ 22](#)] 10 A AC, accuracy class 0.5, electronic nameplate, RJ45
- [SCL6223-0080](#) [[▶ 23](#)] 80 A AC, accuracy class 0.5, electronic nameplate, RJ45
- [SCL6223-0100](#) [[▶ 24](#)] 100 A AC, accuracy class 0.5, electronic nameplate, RJ45

#### **SCL63xx** [[▶ 26](#)] | size 4 (transformer opening 24 mm)

- [SCL6323-0100](#) [[▶ 27](#)] 100 A AC, accuracy class 0.5, electronic nameplate, RJ45
- [SCL6323-0200](#) [[▶ 28](#)] 200 A AC, accuracy class 0.5, electronic nameplate, RJ45
- [SCL6323-0400](#) [[▶ 29](#)] 400 A AC, accuracy class 0.5, electronic nameplate, RJ45

### Overview of measuring transformers

The complete overview of all measuring transformers can be found on the [Beckhoff website](#).

## 1.2 Notes on the documentation

### Intended audience

This description is only intended for the use of trained specialists in control and automation engineering who are familiar with the applicable national standards.

It is essential that the documentation and the following notes and explanations are followed when installing and commissioning these components.

The qualified personnel is obliged to always use the currently valid documentation.

The responsible staff must ensure that the application or use of the products described satisfy all the requirements for safety, including all the relevant laws, regulations, guidelines and standards.

### Disclaimer

The documentation has been prepared with care. The products described are, however, constantly under development.

We reserve the right to revise and change the documentation at any time and without prior announcement.

No claims for the modification of products that have already been supplied may be made on the basis of the data, diagrams and descriptions in this documentation.

### Trademarks

Beckhoff®, ATRO®, EtherCAT®, EtherCAT G®, EtherCAT G10®, EtherCAT P®, MX-System®, Safety over EtherCAT®, TC/BSD®, TwinCAT®, TwinCAT/BSD®, TwinSAFE®, XFC®, XPlanar® and XTS® are registered trademarks of and licensed by Beckhoff Automation GmbH.

Other designations used in this publication may be trademarks whose use by third parties for their own purposes could violate the rights of the owners.



EtherCAT® is registered trademark and patented technology, licensed by Beckhoff Automation GmbH, Germany.

### Copyright

© Beckhoff Automation GmbH & Co. KG, Germany.

The reproduction, distribution and utilization of this document as well as the communication of its contents to others without express authorization are prohibited.

Offenders will be held liable for the payment of damages. All rights reserved in the event of the grant of a patent, utility model or design.

### Third-party brands

Trademarks of third parties may be used in this documentation. You can find the trademark notices here:

<https://www.beckhoff.com/trademarks>

## 1.3 Safety instructions

### Safety regulations

Please note the following safety instructions and explanations!  
Product-specific safety instructions can be found on following pages or in the areas mounting, wiring, commissioning etc.

### Exclusion of liability

All the components are supplied in particular hardware and software configurations appropriate for the application. Modifications to hardware or software configurations other than those described in the documentation are not permitted, and nullify the liability of Beckhoff Automation GmbH & Co. KG.

### Personnel qualification

This description is only intended for trained specialists in control, automation and drive engineering who are familiar with the applicable national standards.

### Signal words

The signal words used in the documentation are classified below. In order to prevent injury and damage to persons and property, read and follow the safety and warning notices.

#### Personal injury warnings

**⚠ DANGER**

Hazard with high risk of death or serious injury.

**⚠ WARNING**

Hazard with medium risk of death or serious injury.

**⚠ CAUTION**

There is a low-risk hazard that could result in medium or minor injury.

#### Warning of damage to property or environment

**NOTICE**

The environment, equipment, or data may be damaged.

#### Information on handling the product



This information includes, for example:  
recommendations for action, assistance or further information on the product.

## 1.4 Intended use

### ⚠ WARNING

#### Intended use

If the equipment is used in a manner not specified by the manufacturer, the protection provided by the equipment may be impaired.

## 1.5 Safety instructions for current transformers

### ⚠ WARNING

#### Current transformer safety instructions

- The devices described are intended for installation by qualified electricians and may only be installed in electrical plant rooms or in closed housings. Any other use or the disregard of these application notes will result in the loss of the warranty/guarantee.
- Observe the applicable laws, standards and regulations.
- Observe the state of the art at the time of installation and the rules of technology.
- Observe the operating instructions and take into account the fact that these can only provide general instructions and that these must be observed.
- The devices may only be installed in dry indoor rooms.
- Do not mount the devices on or near highly flammable materials.
- Check the device carefully for transport damage prior to commissioning. The device must not be put into operation if it is mechanically damaged.
- Operation with a higher current than the rated current specified on the name plate can lead to overheating of the current transformer and thus to burns.

### ⚠ WARNING



#### Risk of injury due to electric shock/arcing/burning

Observe the following instructions (Part 1)!

- The operator must ensure that this product is only installed and operated in perfect working order and by sufficiently qualified and authorized personnel.
- Intended use: industrial, stationary indoor use:  
The analog input devices extend the field of application of the Beckhoff Bus Terminal system with functions for measuring sensor signals via voltage, current or resistance. The intended field of application is data acquisition and control tasks in industrial automation. Use of the device beyond its intended use is not permitted.
- The decision to use and release for operation must be made by an electrotechnical specialist in accordance with the applicable safety rules (occupational health and safety) for the application. National regulations may have to be observed.
- Ensure proper wiring by following all local and national regulations.
- The cables and plugs used must be in the required measuring category or be approved for the applied voltages. Note: when laying such cables, it may be necessary to comply with installation specifications, such as those specified in EN 60204.
- The installation must be thoroughly checked for incorrect wiring before commissioning; appropriate cable labeling/markings is recommended.
- Voltages > 60 V DC / 48 V AC should not be supplied when the control cabinet is open. Supplying these voltages is only permitted in individual cases, when safety precautions have been taken by appropriately qualified personnel.

**⚠ WARNING****Risk of injury due to electric shock/arcing/burning**

Observe the following instructions (Part 2)!

- Check the device before, during and after installation and periodically during breaks in operation for visible damage, such as damaged/cracked sockets/cables/plugs and loose parts. If damage is present, commissioning or further operation is prohibited.
- Ensure that the device and the wiring are de-energized on the field and bus side during installation/assembly/testing/disassembly. The 5 safety rules of electrical engineering must be observed:
  - De-energize
  - Secure against reconnection
  - Ensure that no voltage is present
  - Ground and short-circuit
  - Cover or isolate adjacent live parts
- Avoid foreign bodies entering the housing.
- Do not modify or attempt to repair the device.
- Do not open the device or interfere with the interior of the device.

## 2 SCL60xx - Product description

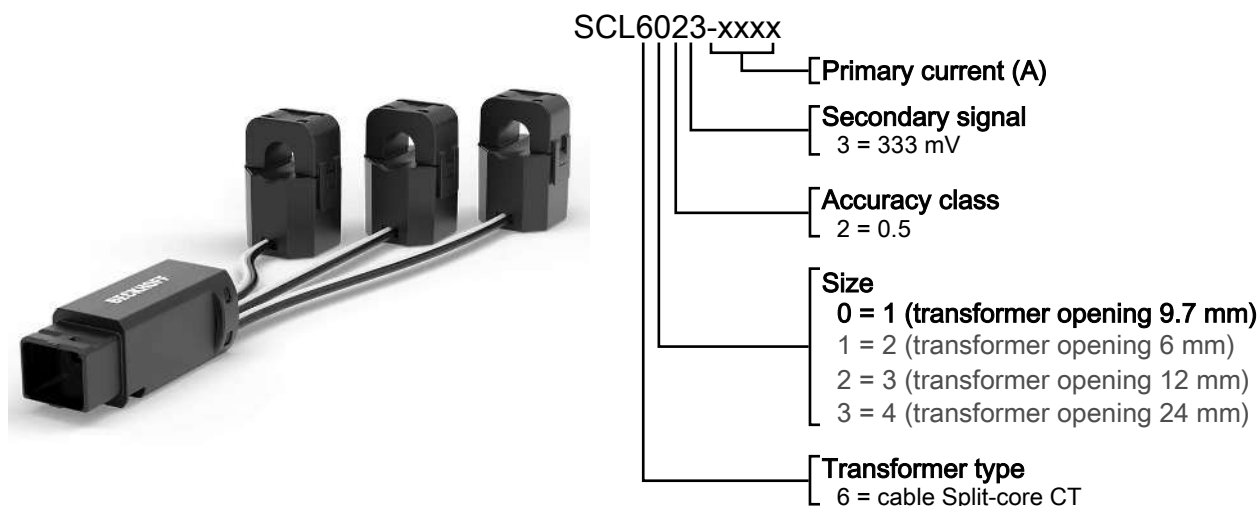

Fig. 2: Left: SCL6023-xxxx Low power split-core transformer, size 1 | Right: Type designation

### SCL6023-xxxx | Low power split-core transformer, 3-channel current interface, accuracy class 0.5, size 1, electronic nameplate, RJ45

The separable, 3-phase SCL6xxx measuring system with RJ45 connection enables flexible retrofitting with minimal installation work and without the need to disconnect the primary conductors. They can be used in places that are difficult to access or where space is limited.

Thanks to the 333 mV output signals, all measuring transformers can be connected easily and without short-circuit terminals using a patch cable.

The cable length between the individual split-core transformers and the connection housing is approx. 25 cm.

The low power split-core transformers with accuracy class 0.5 in size 1 are suitable for use on primary conductors with a maximum diameter of 9.7 mm. They are available for primary currents from 15 A to 75 A.

[SCL6023-0015](#) [▶ [11](#)] 15 A AC, accuracy class 0.5, electronic nameplate, RJ45

[SCL6023-0030](#) [▶ [12](#)] 30 A AC, accuracy class 0.5, electronic nameplate, RJ45

[SCL6023-0060](#) [▶ [13](#)] 60 A AC, accuracy class 0.5, electronic nameplate, RJ45

[SCL6023-0075](#) [▶ [14](#)] 75 A AC, accuracy class 0.5, electronic nameplate, RJ45

They also have electronic nameplates that make manual configuration of the transformer ratios superfluous. The [EL3475](#) EtherCAT Terminal can automatically read out the configuration of a mechanically assembled system, making commissioning easier.

## 2.1 SCL6023-0015 - Technical data

Primary side	SCL6023-0015
Accuracy class*	0.5
Rated frequency $f_R$	50 Hz ... 60 Hz
Frequency range, technical	50 Hz ... 400 Hz
Measuring range, from	0.1 A AC
Measuring range, to	15 A AC
* e.g. when using the electronic nameplate and the adjustment data contained therein via the EtherCAT Terminal EL3475. <b>If the electronic nameplate is not used, observe additional information on accuracy and measurement uncertainties!</b> (see chapter "Notes on operation without electronic nameplate [▶ 40]")	

Secondary side	SCL6023-0015
Secondary signal	333 mV
Electronic nameplate	yes

Insulation properties (only for insulated primary conductors)	SCL6023-0015
Insulation test voltage ( $U_{rms}$ , 50 Hz, 1 Min.)	2500 V AC
Housing material class	UL 94V-0

Operating conditions	SCL6023-0015
Permissible ambient temperature range during operation	-40 °C...+65 °C
Permissible ambient temperature range during storage	-45 °C... +85 °C
permissible relative air humidity	95 %, no condensation
Operating height	up to 2000 m
Protection rating	IP20

General data	SCL6023-0015
Size	1
Max. conductor bushing diameter, primary conductor	9.7 mm
Cable length between split-core transformer and connection housing	approx. 25 cm
Dimensions (W x H x D)	Split-core transformer: 24.8 mm x 38.7 mm x 26.1 mm Connection housing: 24.2 mm x 20.8 mm x 54.6 mm (see chapter "Dimensions size 1 [▶ 15]")
Weight	Approx. 200 g

Standards and regulations	SCL6023-0015
Standards/Regulations	ANSI C57.13; IEC 61869-1
Approvals/markings *)	CE
*) Real applicable approvals/markings see name plate on the side (product labeling)	

## 2.2 SCL6023-0030 - Technical data

Primary side	SCL6023-0030
Accuracy class*	0.5
Rated frequency $f_R$	50 Hz ... 60 Hz
Frequency range, technical	50 Hz ... 400 Hz
Measuring range, from	0.1 A AC
Measuring range, to	30 A AC
* e.g. when using the electronic nameplate and the adjustment data contained therein via the EtherCAT Terminal EL3475. <b>If the electronic nameplate is not used, observe additional information on accuracy and measurement uncertainties!</b> (see chapter "Notes on operation without electronic nameplate [► 40]")	
Secondary side	SCL6023-0030
Secondary signal	333 mV
Electronic nameplate	yes
Insulation properties (only for insulated primary conductors)	SCL6023-0030
Insulation test voltage ( $U_{rms}$ , 50 Hz, 1 Min.)	2500 V AC
Housing material class	UL 94V-0
Operating conditions	SCL6023-0030
Permissible ambient temperature range during operation	-40 °C...+65 °C
Permissible ambient temperature range during storage	-45 °C... +85 °C
permissible relative air humidity	95 %, no condensation
Operating height	up to 2000 m
Protection rating	IP20
General data	SCL6023-0030
Size	1
Max. conductor bushing diameter, primary conductor	9.7 mm
Cable length between split-core transformer and connection housing	approx. 25 cm
Dimensions (W x H x D)	Split-core transformer: 24.8 mm x 38.7 mm x 26.1 mm Connection housing: 24.2 mm x 20.8 mm x 54.6 mm (see chapter "Dimensions size 1 [► 15]")
Weight	Approx. 200 g
Standards and regulations	SCL6023-0030
Standards/Regulations	ANSI C57.13; IEC 61869-1
Approvals/markings *)	CE
*) Real applicable approvals/markings see name plate on the side (product labeling)	

## 2.3 SCL6023-0060 - Technical data

Primary side	SCL6023-0060
Accuracy class*	0.5
Rated frequency $f_R$	50 Hz ... 60 Hz
Frequency range, technical	50 Hz ... 400 Hz
Measuring range, from	0.1 A AC
Measuring range, to	60 A AC
* e.g. when using the electronic nameplate and the adjustment data contained therein via the EtherCAT Terminal EL3475. <b>If the electronic nameplate is not used, observe additional information on accuracy and measurement uncertainties!</b> (see chapter "Notes on operation without electronic nameplate [▶ 40]")	

Secondary side	SCL6023-0060
Secondary signal	333 mV
Electronic nameplate	yes

Insulation properties (only for insulated primary conductors)	SCL6023-0060
Insulation test voltage ( $U_{rms}$ , 50 Hz, 1 Min.)	2500 V AC
Housing material class	UL 94V-0

Operating conditions	SCL6023-0060
Permissible ambient temperature range during operation	-40 °C...+65 °C
Permissible ambient temperature range during storage	-45 °C... +85 °C
permissible relative air humidity	95 %, no condensation
Operating height	up to 2000 m
Protection rating	IP20

General data	SCL6023-0060
Size	1
Max. conductor bushing diameter, primary conductor	9.7 mm
Cable length between split-core transformer and connection housing	approx. 25 cm
Dimensions (W x H x D)	Split-core transformer: 24.8 mm x 38.7 mm x 26.1 mm Connection housing: 24.2 mm x 20.8 mm x 54.6 mm (see chapter "Dimensions size 1 [▶ 15]")
Weight	Approx. 200 g

Standards and regulations	SCL6023-0060
Standards/Regulations	ANSI C57.13; IEC 61869-1
Approvals/markings *)	CE
*) Real applicable approvals/markings see name plate on the side (product labeling)	

## 2.4 SCL6023-0075 - Technical data

Primary side	SCL6023-0075
Accuracy class*	0.5
Rated frequency $f_R$	50 Hz ... 60 Hz
Frequency range, technical	50 Hz ... 400 Hz
Measuring range, from	0.1 A AC
Measuring range, to	75 A AC
* e.g. when using the electronic nameplate and the adjustment data contained therein via the EtherCAT Terminal EL3475. <b>If the electronic nameplate is not used, observe additional information on accuracy and measurement uncertainties!</b> (see chapter "Notes on operation without electronic nameplate [► 40]")	
Secondary side	SCL6023-0075
Secondary signal	333 mV
Electronic nameplate	yes
Insulation properties (only for insulated primary conductors)	SCL6023-0075
Insulation test voltage ( $U_{rms}$ , 50 Hz, 1 Min.)	2500 V AC
Housing material class	UL 94V-0
Operating conditions	SCL6023-0075
Permissible ambient temperature range during operation	-40 °C...+65 °C
Permissible ambient temperature range during storage	-45 °C... +85 °C
permissible relative air humidity	95 %, no condensation
Operating height	up to 2000 m
Protection rating	IP20
General data	SCL6023-0075
Size	1
Max. conductor bushing diameter, primary conductor	9.7 mm
Cable length between split-core transformer and connection housing	approx. 25 cm
Dimensions (W x H x D)	Split-core transformer: 24.8 mm x 38.7 mm x 26.1 mm Connection housing: 24.2 mm x 20.8 mm x 54.6 mm (see chapter "Dimensions size 1 [► 15]")
Weight	Approx. 200 g
Standards and regulations	SCL6023-0075
Standards/Regulations	ANSI C57.13; IEC 61869-1
Approvals/markings *)	CE
*) Real applicable approvals/markings see name plate on the side (product labeling)	

## 2.5 Dimensions size 1

Single current transformer of low power split-core transformer SCL60xx, size 1

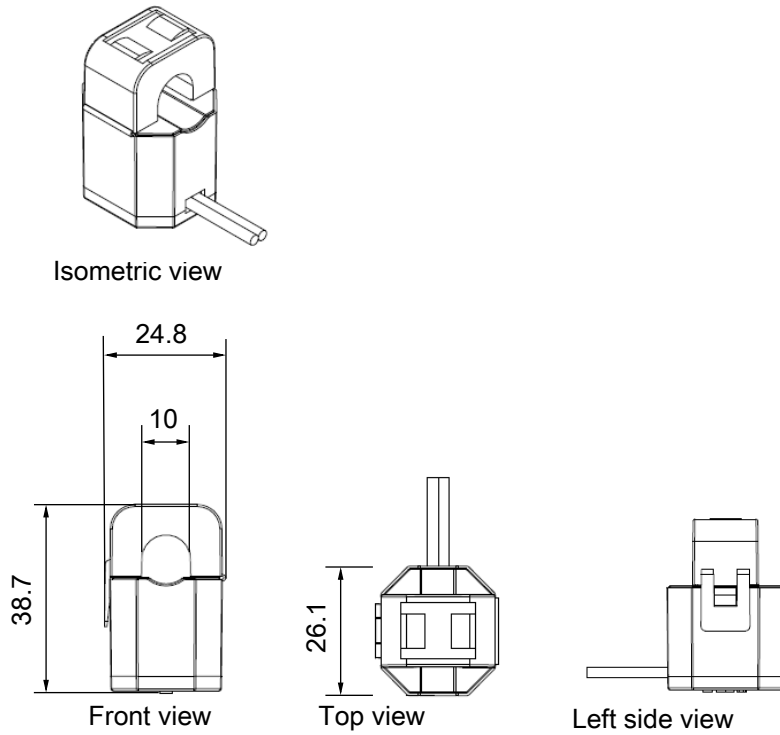

Fig. 3: Dimensions of individual SCL60xx low power split-core transformers, size 1 (all values in mm)

Housing for low power transformer SCLxxx3, 3-channel current interface, RJ45

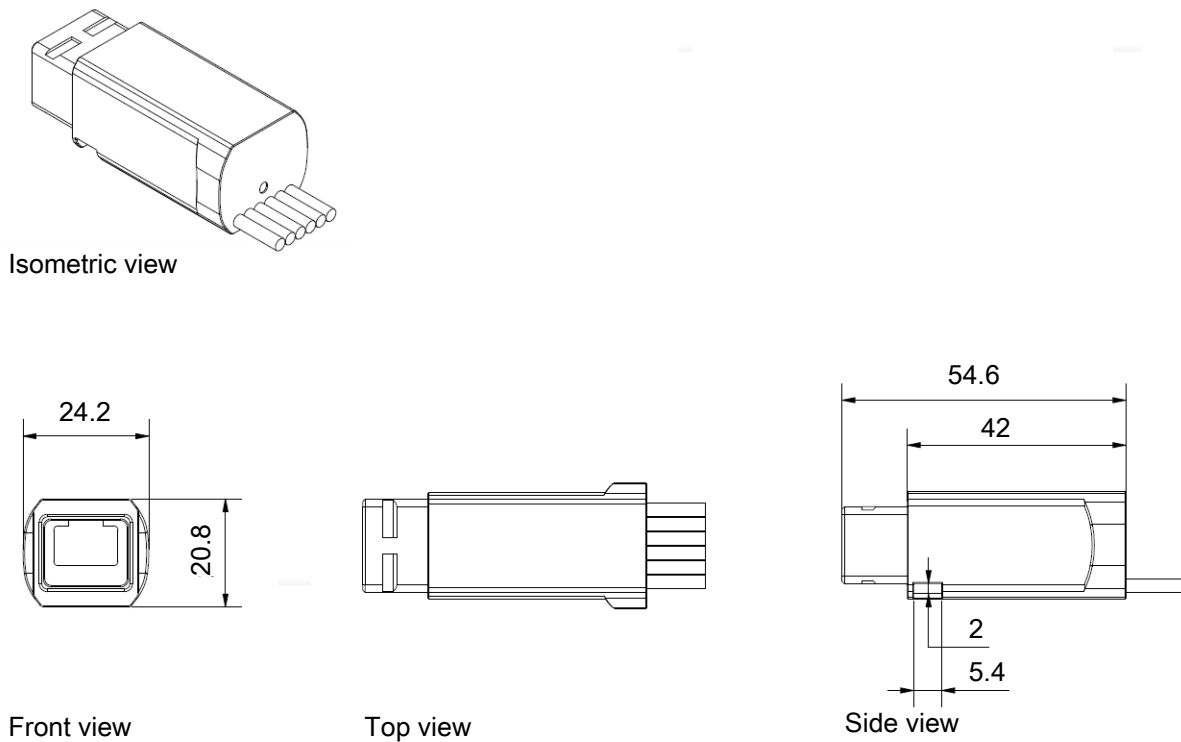

Fig. 4: Dimensions low power transformer SCLxxx3, 3-channel current interface, RJ45 (all values in mm)

### 3 SCL61xx - Product description

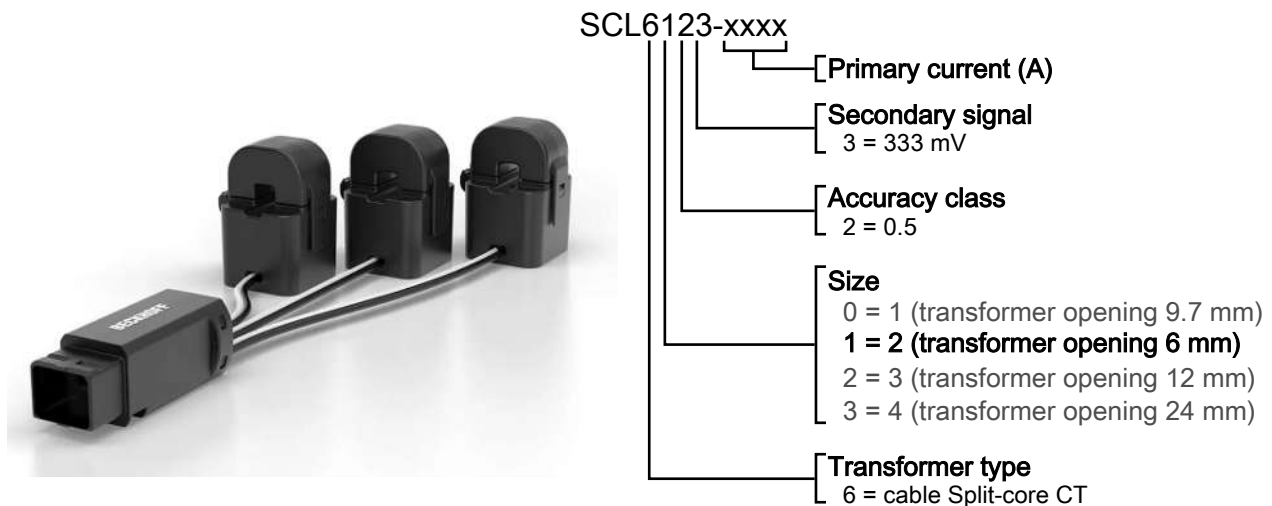

Fig. 5: Left: SCL61xx low power split-core transformer, size 2 | Right: Type designation

#### **SCL61xx | Low power split-core transformer, 3-channel current interface, accuracy class 0.5, size 2, electronic nameplate, RJ45**

The separable, 3-phase SCL6xxx measuring system with RJ45 connection enables flexible retrofitting with minimal installation work and without the need to disconnect the primary conductors. They can be used in places that are difficult to access or where space is limited.

Thanks to the 333 mV output signals, all measuring transformers can be connected easily and without short-circuit terminals using a patch cable.

The cable length between the individual split-core transformers and the connection housing is approx. 25 cm.

The low power split-core transformers with accuracy class 0.5 in size 2 are suitable for use on primary conductors with a maximum diameter of 6 mm. They are available for primary currents from 20 A to 60 A:

[SCL6123-0020](#) [▶ 17] 20 A AC, accuracy class 0.5, electronic nameplate, RJ45

[SCL6123-0040](#) [▶ 18] 40 A AC, accuracy class 0.5, electronic nameplate, RJ45

[SCL6123-0060](#) [▶ 19] 60 A AC, accuracy class 0.5, electronic nameplate, RJ45

They also have electronic nameplates that make manual configuration of the transformer ratios superfluous. The [EL3475](#) EtherCAT Terminal can automatically read out the configuration of a mechanically assembled system, making commissioning easier.

### 3.1 SCL6123-0020 - Technical data

Primary side	SCL6123-0020
Accuracy class*	0.5
Rated frequency $f_R$	50 Hz ... 60 Hz
Frequency range, technical	50 Hz ... 400 Hz
Measuring range, from	0.1 A AC
Measuring range, to	20 A AC
* e.g. when using the electronic nameplate and the adjustment data contained therein via the EtherCAT Terminal EL3475. <b>If the electronic nameplate is not used, observe additional information on accuracy and measurement uncertainties!</b> (see chapter "Notes on operation without electronic nameplate [► 40]")	

Secondary side	SCL6123-0020
Secondary signal	333 mV
Electronic nameplate	yes

Insulation properties (only for insulated primary conductors)	SCL6123-0020
Insulation test voltage ( $U_{rms}$ , 50 Hz, 1 Min.)	4000 V AC
Housing material class	UL 94V-0
Measurement category / overvoltage category	250 V CAT III

Operating conditions	SCL6123-0020
Permissible ambient temperature range during operation	-40 °C...+70 °C
Permissible ambient temperature range during storage	-45 °C... +85 °C
permissible relative air humidity	95 %, no condensation
Operating height	up to 2000 m
Protection rating	IP20

General data	SCL6123-0020
Size	2
Max. conductor bushing diameter, primary conductor	6 mm
Cable length between split-core transformer and connection housing	approx. 25 cm
Dimensions (W x H x D)	Split-core transformer: 33.3 mm x 43.5 mm x 30.4 mm Connection housing: 24.2 mm x 20.8 mm x 54.6 mm (see chapter "Dimensions size 2 [► 20]")
Weight	Approx. 320 g

Standards and regulations	SCL6123-0020
Standards/Regulations	UL2808; IEC 61010-1, IEC 61869-1
Approvals/markings *)	CE
*) Real applicable approvals/markings see name plate on the side (product labeling)	

## 3.2 SCL6123-0040 - Technical data

Primary side	SCL6123-0040
Accuracy class*	0.5
Rated frequency $f_R$	50 Hz ... 60 Hz
Frequency range, technical	50 Hz ... 400 Hz
Measuring range, from	0.1 A AC
Measuring range, to	40 A AC
* e.g. when using the electronic nameplate and the adjustment data contained therein via the EtherCAT Terminal EL3475. <b>If the electronic nameplate is not used, observe additional information on accuracy and measurement uncertainties!</b> (see chapter "Notes on operation without electronic nameplate [► 40]")	
Secondary side	SCL6123-0040
Secondary signal	333 mV
Electronic nameplate	yes
Insulation properties (only for insulated primary conductors)	SCL6123-0040
Insulation test voltage ( $U_{rms}$ , 50 Hz, 1 Min.)	4000 V AC
Housing material class	UL 94V-0
Measurement category / overvoltage category	250 V CAT III
Operating conditions	SCL6123-0040
Permissible ambient temperature range during operation	-40 °C...+70 °C
Permissible ambient temperature range during storage	-45 °C... +85 °C
permissible relative air humidity	95 %, no condensation
Operating height	up to 2000 m
Protection rating	IP20
General data	SCL6123-0040
Size	2
Max. conductor bushing diameter, primary conductor	6 mm
Cable length between split-core transformer and connection housing	approx. 25 cm
Dimensions (W x H x D)	Split-core transformer: 33.3 mm x 43.5 mm x 30.4 mm Connection housing: 24.2 mm x 20.8 mm x 54.6 mm (see chapter "Dimensions size 2 [► 20]")
Weight	Approx. 320 g
Standards and regulations	SCL6123-0040
Standards/Regulations	UL2808; IEC 61010-1, IEC 61869-1
Approvals/markings *)	CE
*) Real applicable approvals/markings see name plate on the side (product labeling)	

### 3.3 SCL6123-0060 - Technical data

Primary side	SCL6123-0060
Accuracy class*	0.5
Rated frequency $f_R$	50 Hz ... 60 Hz
Frequency range, technical	50 Hz ... 400 Hz
Measuring range, from	0.1 A AC
Measuring range, to	60 A AC
* e.g. when using the electronic nameplate and the adjustment data contained therein via the EtherCAT Terminal EL3475. <b>If the electronic nameplate is not used, observe additional information on accuracy and measurement uncertainties!</b> (see chapter "Notes on operation without electronic nameplate [► 40]")	

Secondary side	SCL6123-0060
Secondary signal	333 mV
Electronic nameplate	yes

Insulation properties (only for insulated primary conductors)	SCL6123-0060
Insulation test voltage ( $U_{rms}$ , 50 Hz, 1 Min.)	4000 V AC
Housing material class	UL 94V-0
Measurement category / overvoltage category	250 V CAT III

Operating conditions	SCL6123-0060
Permissible ambient temperature range during operation	-40 °C...+70 °C
Permissible ambient temperature range during storage	-45 °C... +85 °C
permissible relative air humidity	95 %, no condensation
Operating height	up to 2000 m
Protection rating	IP20

General data	SCL6123-0060
Size	2
Max. conductor bushing diameter, primary conductor	6 mm
Cable length between split-core transformer and connection housing	approx. 25 cm
Dimensions (W x H x D)	Split-core transformer: 33.3 mm x 43.5 mm x 30.4 mm Connection housing: 24.2 mm x 20.8 mm x 54.6 mm (see chapter "Dimensions size 2 [► 20]")
Weight	Approx. 320 g

Standards and regulations	SCL6123-0060
Standards/Regulations	UL2808; IEC 61010-1, IEC 61869-1
Approvals/markings *)	CE
*) Real applicable approvals/markings see name plate on the side (product labeling)	

### 3.4 Dimensions size 2

Single current transformer of low power split-core transformer SCL61xx, size 2

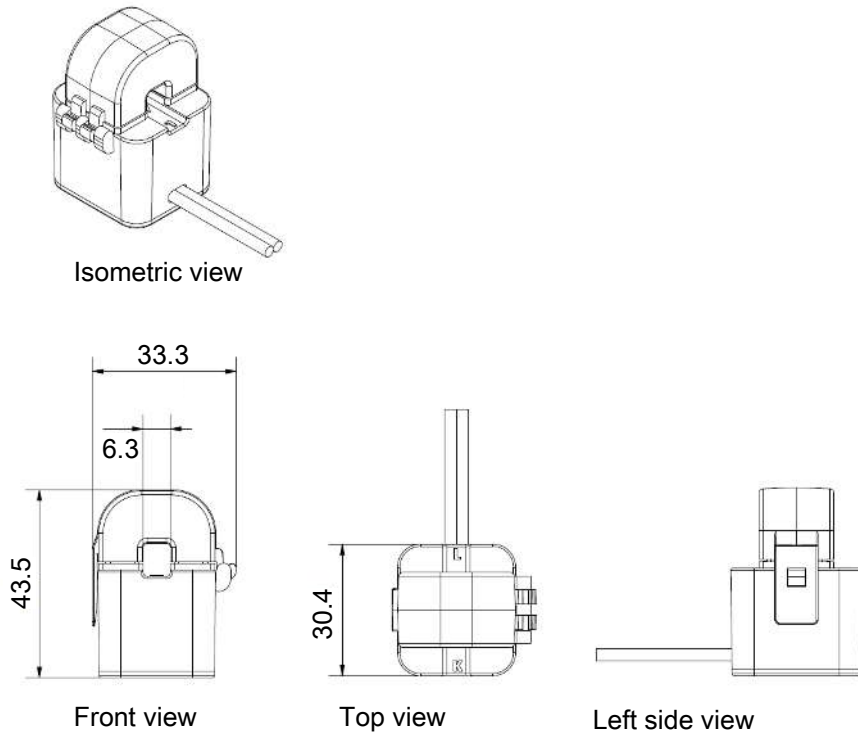

Fig. 6: Dimensions of individual SCL61xx low power split-core transformers, size 2 (all values in mm)

Housing for low power transformer SCLxxx3, 3-channel current interface, RJ45

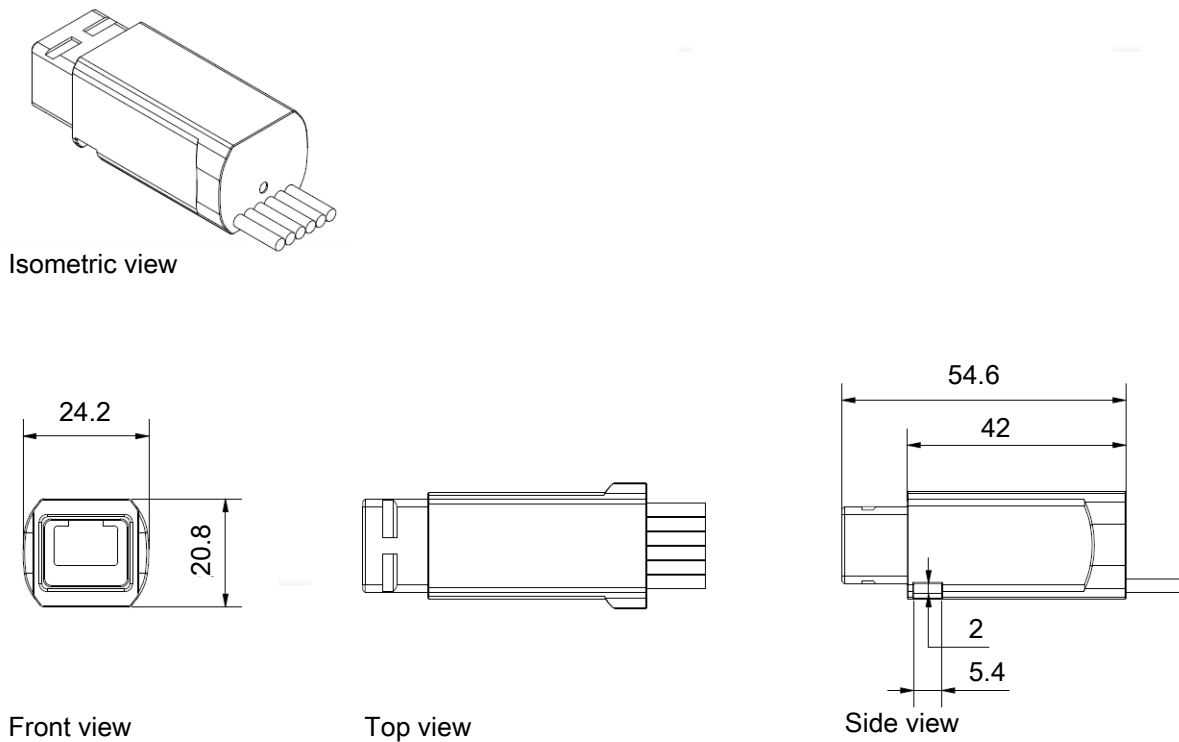

Fig. 7: Dimensions low power transformer SCLxxx3, 3-channel current interface, RJ45 (all values in mm)

## 4 SCL62xx - Product description

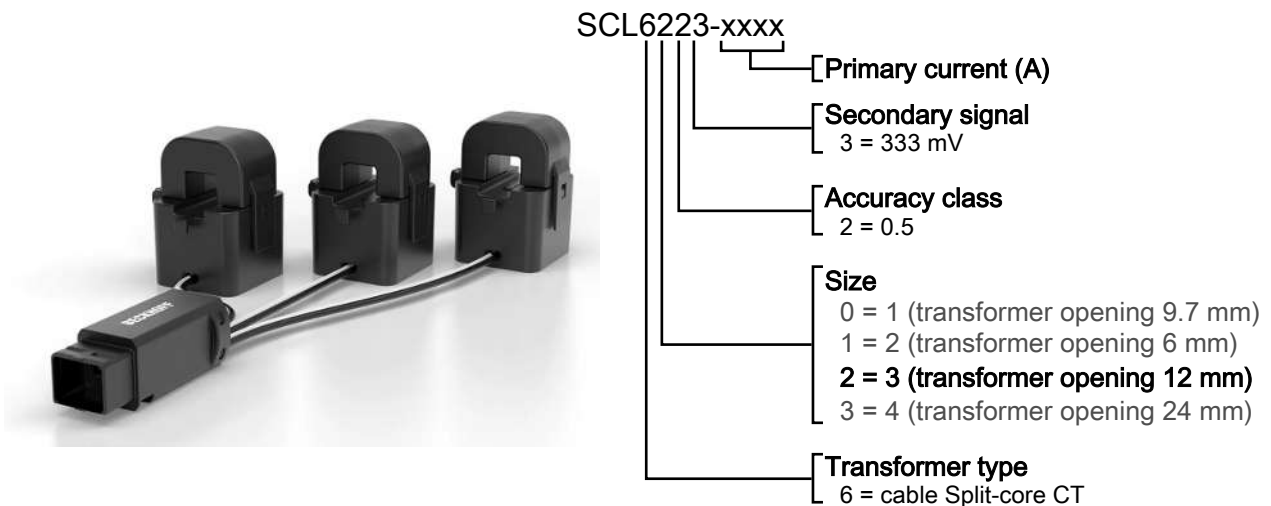

Fig. 8: Left: SCL62xx low power split-core transformer, size 3 | Right: Type designation

### SCL62xx | Low power split-core transformer, 3-channel current interface, accuracy class 0.5, size 3, electronic nameplate, RJ45

The separable, 3-phase SCL6xxx measuring system with RJ45 connection enables flexible retrofitting with minimal installation work and without the need to disconnect the primary conductors. They can be used in places that are difficult to access or where space is limited.

Thanks to the 333 mV output signals, all measuring transformers can be connected easily and without short-circuit terminals using a patch cable.

The cable length between the individual split-core transformers and the connection housing is approx. 25 cm.

The low power split-core transformers with accuracy class 0.5 in size 3 are suitable for use on primary conductors with a maximum diameter of 12 mm. They are available for primary currents from 10 A to 100 A.

[SCL6223-0010](#) | [22](#) | 10 A AC, accuracy class 0.5, electronic nameplate, RJ45

[SCL6223-0080](#) | [23](#) | 80 A AC, accuracy class 0.5, electronic nameplate, RJ45

[SCL6223-0100](#) | [24](#) | 100 A AC, accuracy class 0.5, electronic nameplate, RJ45

They also have electronic nameplates that make manual configuration of the transformer ratios superfluous. The [EL3475](#) EtherCAT Terminal can automatically read out the configuration of a mechanically assembled system, making commissioning easier.

## 4.1 SCL6223-0010 - Technical data

Primary side	SCL6223-0010
Accuracy class*	0.5
Rated frequency $f_R$	50 Hz ... 60 Hz
Frequency range, technical	50 Hz ... 400 Hz
Measuring range, from	0.1 A AC
Measuring range, to	10 A AC
* e.g. when using the electronic nameplate and the adjustment data contained therein via the EtherCAT Terminal EL3475. <b>If the electronic nameplate is not used, observe additional information on accuracy and measurement uncertainties!</b> (see chapter "Notes on operation without electronic nameplate [► 40]")	
Secondary side	SCL6223-0010
Secondary signal	333 mV
Electronic nameplate	yes
Insulation properties (only for insulated primary conductors)	SCL6223-0010
Insulation test voltage ( $U_{rms}$ , 50 Hz, 1 Min.)	4000 V AC
Housing material class	UL 94V-0
Measurement category / overvoltage category	250 V CAT III
Operating conditions	SCL6223-0010
Permissible ambient temperature range during operation	-40 °C...+70 °C
Permissible ambient temperature range during storage	-45 °C... +85 °C
permissible relative air humidity	95 %, no condensation
Operating height	up to 2000 m
Protection rating	IP20
General data	SCL6223-0010
Size	3
Max. conductor bushing diameter, primary conductor	12 mm
Cable length between split-core transformer and connection housing	approx. 25 cm
Dimensions (W x H x D)	Split-core transformer: 41.5 mm x 51.9 mm x 46.9 mm Connection housing: 24.2 mm x 20.8 mm x 54.6 mm (see chapter "Dimensions size 3 [► 25]")
Weight	Approx. 380 g
Standards and regulations	SCL6223-0010
Standards/Regulations	UL2808; IEC 61010-1, IEC 61869-1
Approvals/markings *)	CE
*) Real applicable approvals/markings see name plate on the side (product labeling)	

## 4.2 SCL6223-0080 - Technical data

Primary side	SCL6223-0080
Accuracy class*	0.5
Rated frequency $f_R$	50 Hz ... 60 Hz
Frequency range, technical	50 Hz ... 400 Hz
Measuring range, from	0.1 A AC
Measuring range, to	80 A AC
* e.g. when using the electronic nameplate and the adjustment data contained therein via the EtherCAT Terminal EL3475. <b>If the electronic nameplate is not used, observe additional information on accuracy and measurement uncertainties!</b> (see chapter "Notes on operation without electronic nameplate [► 40]")	

Secondary side	SCL6223-0080
Secondary signal	333 mV
Electronic nameplate	yes

Insulation properties (only for insulated primary conductors)	SCL6223-0080
Insulation test voltage ( $U_{rms}$ , 50 Hz, 1 Min.)	4000 V AC
Housing material class	UL 94V-0
Measurement category / overvoltage category	250 V CAT III

Operating conditions	SCL6223-0080
Permissible ambient temperature range during operation	-40 °C...+70 °C
Permissible ambient temperature range during storage	-45 °C... +85 °C
permissible relative air humidity	95 %, no condensation
Operating height	up to 2000 m
Protection rating	IP20

General data	SCL6223-0080
Size	3
Max. conductor bushing diameter, primary conductor	12 mm
Cable length between split-core transformer and connection housing	approx. 25 cm
Dimensions (W x H x D)	Split-core transformer: 41.5 mm x 51.9 mm x 46.9 mm Connection housing: 24.2 mm x 20.8 mm x 54.6 mm (see chapter "Dimensions size 3 [► 25]")
Weight	Approx. 380 g

Standards and regulations	SCL6223-0080
Standards/Regulations	UL2808; IEC 61010-1, IEC 61869-1
Approvals/markings *)	CE
*) Real applicable approvals/markings see name plate on the side (product labeling)	

### 4.3 SCL6223-0100 - Technical data

Primary side	SCL6223-0100
Accuracy class*	0.5
Rated frequency $f_R$	50 Hz ... 60 Hz
Frequency range, technical	50 Hz ... 400 Hz
Measuring range, from	0.1 A AC
Measuring range, to	100 A AC
* e.g. when using the electronic nameplate and the adjustment data contained therein via the EtherCAT Terminal EL3475. <b>If the electronic nameplate is not used, observe additional information on accuracy and measurement uncertainties!</b> (see chapter "Notes on operation without electronic nameplate [► 40]")	
Secondary side	SCL6223-0100
Secondary signal	333 mV
Electronic nameplate	yes
Insulation properties (only for insulated primary conductors)	SCL6223-0100
Insulation test voltage ( $U_{rms}$ , 50 Hz, 1 Min.)	4000 V AC
Housing material class	UL 94V-0
Measurement category / overvoltage category	250 V CAT III
Operating conditions	SCL6223-0100
Permissible ambient temperature range during operation	-40 °C...+70 °C
Permissible ambient temperature range during storage	-45 °C... +85 °C
permissible relative air humidity	95 %, no condensation
Operating height	up to 2000 m
Protection rating	IP20
General data	SCL6223-0100
Size	3
Max. conductor bushing diameter, primary conductor	12 mm
Cable length between split-core transformer and connection housing	approx. 25 cm
Dimensions (W x H x D)	Split-core transformer: 41.5 mm x 51.9 mm x 46.9 mm Connection housing: 24.2 mm x 20.8 mm x 54.6 mm (see chapter "Dimensions size 3 [► 25]")
Weight	Approx. 380 g
Standards and regulations	SCL6223-0100
Standards/Regulations	UL2808; IEC 61010-1, IEC 61869-1
Approvals/markings *)	CE
*) Real applicable approvals/markings see name plate on the side (product labeling)	

## 4.4 Dimensions size 3

Single current transformer of low power split-core transformer SCL62xx, size 3

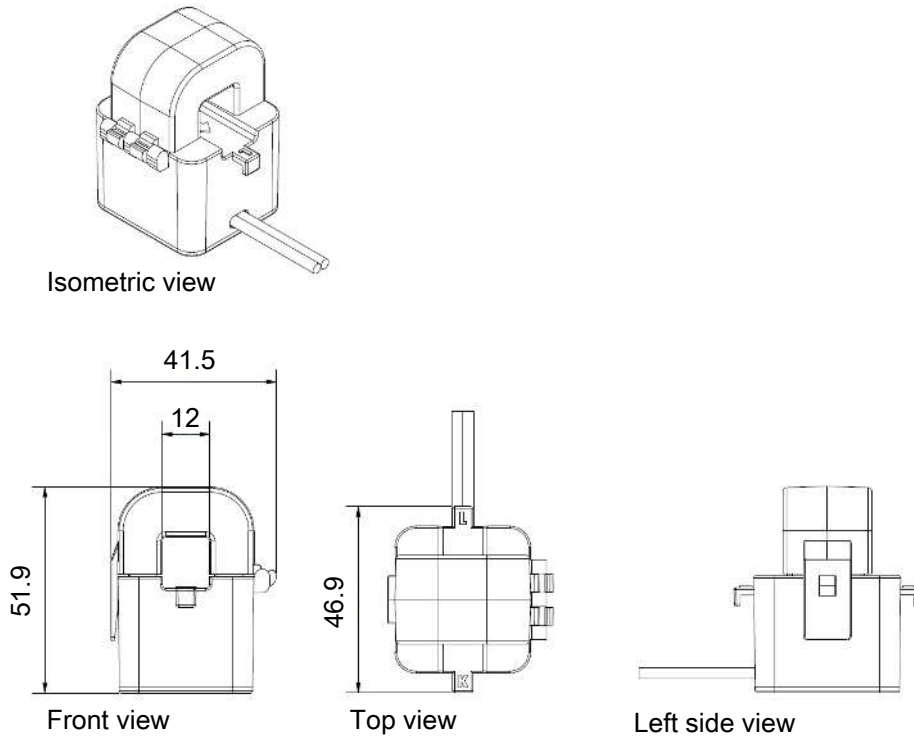

Fig. 9: Dimensions of individual SCL62xx low power split-core transformers, size 3 (all values in mm)

Housing for low power transformer SCLxxx3, 3-channel current interface, RJ45

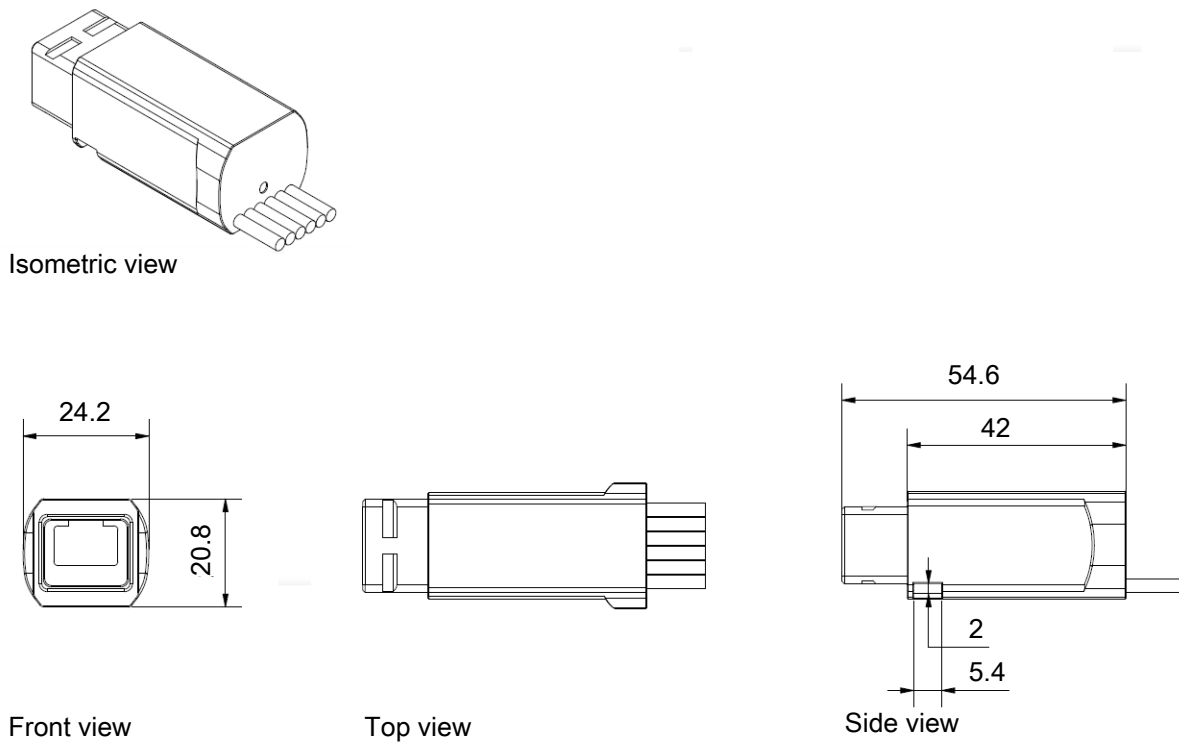

Fig. 10: Dimensions low power transformer SCLxxx3, 3-channel current interface, RJ45 (all values in mm)

## 5 SCL63xx - Product description

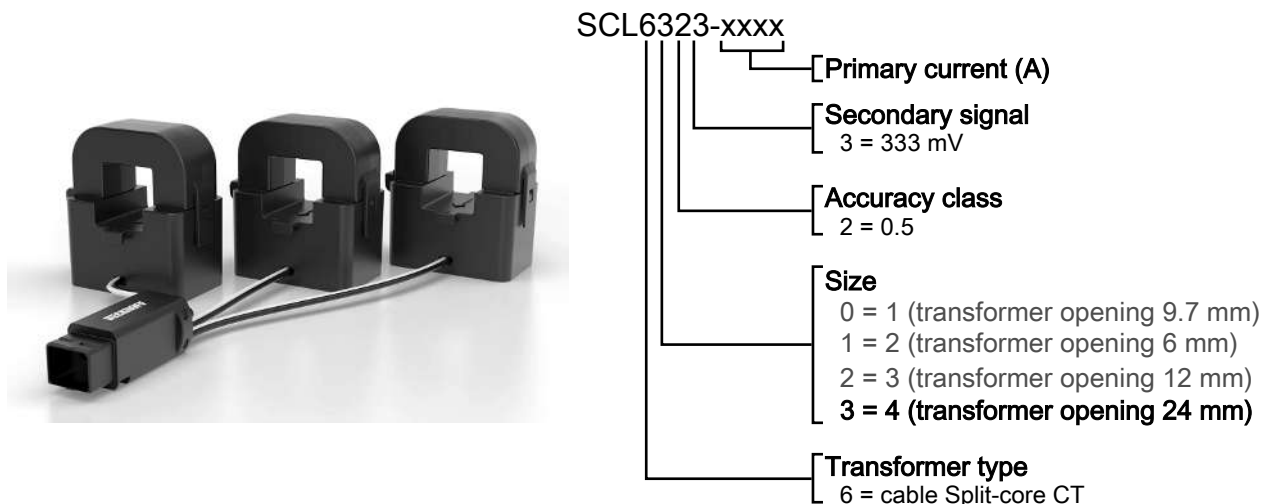

Fig. 11: Left: SCL63xx low power split-core transformer, size 4 | Right: Type designation

### SCL63xx | Low power split-core transformer, 3-channel current interface, accuracy class 0.5, size 4, electronic nameplate, RJ45

The separable, 3-phase SCL6xxx measuring system with RJ45 connection enables flexible retrofitting with minimal installation work and without the need to disconnect the primary conductors. They can be used in places that are difficult to access or where space is limited.

Thanks to the 333 mV output signals, all measuring transformers can be connected easily and without short-circuit terminals using a patch cable.

The cable length between the individual split-core transformers and the connection housing is approx. 25 cm.

The low power split-core transformers with accuracy class 0.5 in size 4 are suitable for use on primary conductors with a maximum diameter of 24 mm. They are available for primary currents from 100 A to 400 A.

[SCL6323-0100](#) [▶ 27] 100 A AC, accuracy class 0.5, electronic nameplate, RJ45

[SCL6323-0200](#) [▶ 28] 200 A AC, accuracy class 0.5, electronic nameplate, RJ45

[SCL6323-0400](#) [▶ 29] 400 A AC, accuracy class 0.5, electronic nameplate, RJ45

They also have electronic nameplates that make manual configuration of the transformer ratios superfluous. The [EL3475](#) EtherCAT Terminal can automatically read out the configuration of a mechanically assembled system, making commissioning easier.

## 5.1 SCL6323-0100 - Technical data

Primary side	SCL6323-0100
Accuracy class*	0.5
Rated frequency $f_R$	50 Hz ... 60 Hz
Frequency range, technical	50 Hz ... 400 Hz
Measuring range, from	0.1 A AC
Measuring range, to	100 A AC
* e.g. when using the electronic nameplate and the adjustment data contained therein via the EtherCAT Terminal EL3475. <b>If the electronic nameplate is not used, observe additional information on accuracy and measurement uncertainties!</b> (see chapter "Notes on operation without electronic nameplate [▶ 40]")	
Secondary side	SCL6323-0100
Secondary signal	333 mV
Electronic nameplate	yes
Insulation properties (only for insulated primary conductors)	SCL6323-0100
Insulation test voltage ( $U_{rms}$ , 50 Hz, 1 Min.)	4000 V AC
Housing material class	UL 94V-0
Measurement category / overvoltage category	250 V CAT IV
Operating conditions	SCL6323-0100
Permissible ambient temperature range during operation	-40 °C...+70 °C
Permissible ambient temperature range during storage	-45 °C... +85 °C
permissible relative air humidity	95 %, no condensation
Operating height	up to 2000 m
Protection rating	IP20
General data	SCL6323-0100
Size	4
Max. conductor bushing diameter, primary conductor	24 mm
Cable length between split-core transformer and connection housing	approx. 25 cm
Dimensions (W x H x D)	Split-core transformer: 65.9 mm x 68.5 mm x 46.3 mm Connection housing: 24.2 mm x 20.8 mm x 54.6 mm (see chapter "Dimensions size 4 [▶ 30]")
Weight	Approx. 740 g
Standards and regulations	SCL6323-0100
Standards/Regulations	UL2808; IEC 61010-1, IEC 61869-1
Approvals/markings *)	CE
*) Real applicable approvals/markings see name plate on the side (product labeling)	

## 5.2 SCL6323-0200 - Technical data

Primary side	SCL6323-0200
Accuracy class*	0.5
Rated frequency $f_R$	50 Hz ... 60 Hz
Frequency range, technical	50 Hz ... 400 Hz
Measuring range, from	0.1 A AC
Measuring range, to	200 A AC
* e.g. when using the electronic nameplate and the adjustment data contained therein via the EtherCAT Terminal EL3475. <b>If the electronic nameplate is not used, observe additional information on accuracy and measurement uncertainties!</b> (see chapter "Notes on operation without electronic nameplate [► 40]")	
Secondary side	SCL6323-0200
Secondary signal	333 mV
Electronic nameplate	yes
Insulation properties (only for insulated primary conductors)	SCL6323-0200
Insulation test voltage ( $U_{rms}$ , 50 Hz, 1 Min.)	4000 V AC
Housing material class	UL 94V-0
Measurement category / overvoltage category	250 V CAT IV
Operating conditions	SCL6323-0200
Permissible ambient temperature range during operation	-40 °C...+70 °C
Permissible ambient temperature range during storage	-45 °C... +85 °C
permissible relative air humidity	95 %, no condensation
Operating height	up to 2000 m
Protection rating	IP20
General data	SCL6323-0200
Size	4
Max. conductor bushing diameter, primary conductor	24 mm
Cable length between split-core transformer and connection housing	approx. 25 cm
Dimensions (W x H x D)	Split-core transformer: 65.9 mm x 68.5 mm x 46.3 mm Connection housing: 24.2 mm x 20.8 mm x 54.6 mm (see chapter "Dimensions size 4 [► 30]")
Weight	Approx. 740 g
Standards and regulations	SCL6323-0200
Standards/Regulations	UL2808; IEC 61010-1, IEC 61869-1
Approvals/markings *)	CE
*) Real applicable approvals/markings see name plate on the side (product labeling)	

### 5.3 SCL6323-0400 - Technical data

Primary side	SCL6323-0400
Accuracy class*	0.5
Rated frequency $f_R$	50 Hz ... 60 Hz
Frequency range, technical	50 Hz ... 400 Hz
Measuring range, from	0.1 A AC
Measuring range, to	400 A AC
* e.g. when using the electronic nameplate and the adjustment data contained therein via the EtherCAT Terminal EL3475. <b>If the electronic nameplate is not used, observe additional information on accuracy and measurement uncertainties!</b> (see chapter "Notes on operation without electronic nameplate [► 40]")	

Secondary side	SCL6323-0400
Secondary signal	333 mV
Electronic nameplate	yes

Insulation properties (only for insulated primary conductors)	SCL6323-0400
Insulation test voltage ( $U_{rms}$ , 50 Hz, 1 Min.)	4000 V AC
Housing material class	UL 94V-0
Measurement category / overvoltage category	250 V CAT IV

Operating conditions	SCL6323-0400
Permissible ambient temperature range during operation	-40 °C...+70 °C
Permissible ambient temperature range during storage	-45 °C... +85 °C
permissible relative air humidity	95 %, no condensation
Operating height	up to 2000 m
Protection rating	IP20

General data	SCL6323-0400
Size	4
Max. conductor bushing diameter, primary conductor	24 mm
Cable length between split-core transformer and connection housing	approx. 25 cm
Dimensions (W x H x D)	Split-core transformer: 65.9 mm x 68.5 mm x 46.3 mm Connection housing: 24.2 mm x 20.8 mm x 54.6 mm (see chapter "Dimensions size 4 [► 30]")
Weight	Approx. 740 g

Standards and regulations	SCL6323-0400
Standards/Regulations	UL2808; IEC 61010-1, IEC 61869-1
Approvals/markings *)	CE
*) Real applicable approvals/markings see name plate on the side (product labeling)	

## 5.4 Dimensions size 4

Single current transformer of low power split-core transformer SCL63xx, size 4

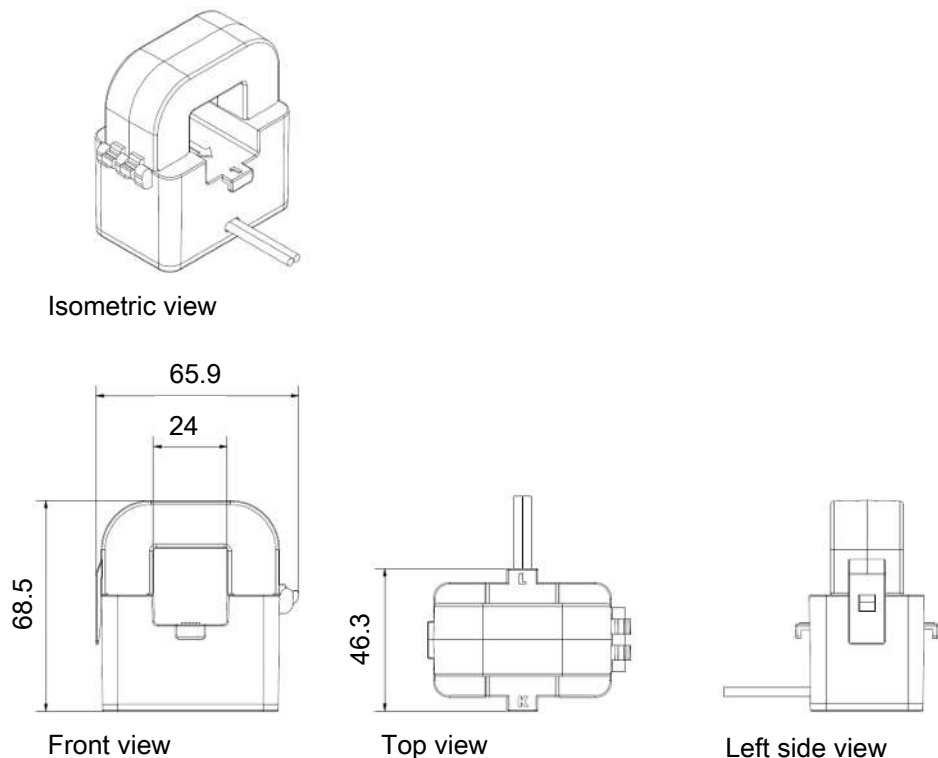

Fig. 12: Dimensions of individual SCL63xx low power split-core transformers, size 4 (all values in mm)

Housing for low power transformer SCLxxx3, 3-channel current interface, RJ45

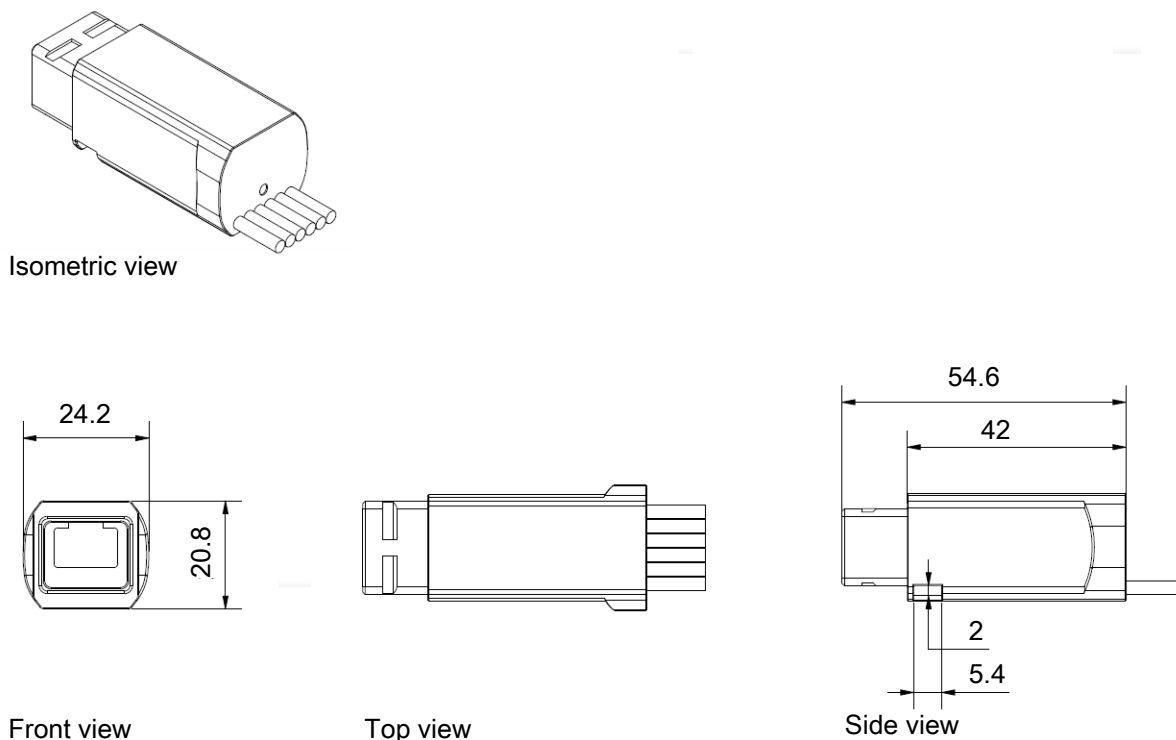

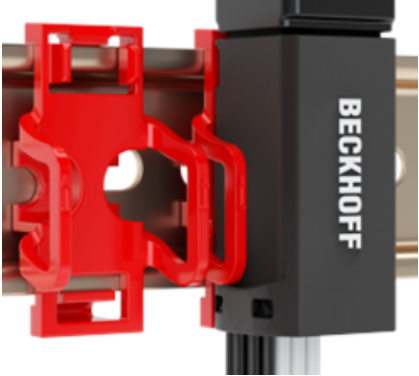

Fig. 13: Dimensions low power transformer SCLxxx3, 3-channel current interface, RJ45 (all values in mm)

## 6 Accessories

We recommend the following accessories for wiring the low power split-core transformer with the EL3475-xxxx EtherCAT Terminals for distributed power measurement:

Name	Description	Figure
<p>ZK2003-91D1-3xxx</p>	<p>Sensor cable, shielded, PVC, 4 x 2 AWG26, fixed installation, gray</p>	
<p>C9900-K938</p>	<p>Ethernet/EtherCAT connector, for field assembly, IP65/67</p>	
<p>ZB8201-0900</p>	<p>Snap-on mounting SCLxxxx/SVLxxxx</p>	

## 7 Basics current transformers

Basic information on the technology area of current transformers is given in the following. The information is of general nature; so it is imperative to check the extent to which these notes apply to your specific application.

### 7.1 Function and structure

A current transformer is a transformer that converts an input current into a processable current signal at the output. Current transformers are mainly used to transform high currents to directly measurable smaller values in the milliamp or lower amp range. In a classic current transformer, the input current is proportional to the output current. Due to the physical operating principle and the mechanical structure, the current signal is electrically isolated for transmission to the evaluation electronics.

A current transformer basically consists of a small number of windings on the primary side and a larger number of windings on the secondary side. The current being converted flows through the primary side. The windings are usually wound on an alternating magnetic ferrite ring core.

The toroidal or **ring-type CT** is a typical type of transformer. Here, the busbar or current-carrying line is often used as the primary winding which is fed through the ring core of the transformer. Thus, the rail or line constitutes the primary winding with one turn. The secondary winding is located on the ring core. The transformation is determined by the primary to secondary winding ratio. The classic ring-type CT design is shown in the figure on the left below.

Another classic type is the **coil current transformer**. In this type of transformer, the primary winding is a current-carrying wire that is wound around the primary side of the ring core. The number of primary windings is  $> 1$ , but is smaller than the number of secondary windings. This principle is illustrated in the figure on the right below.

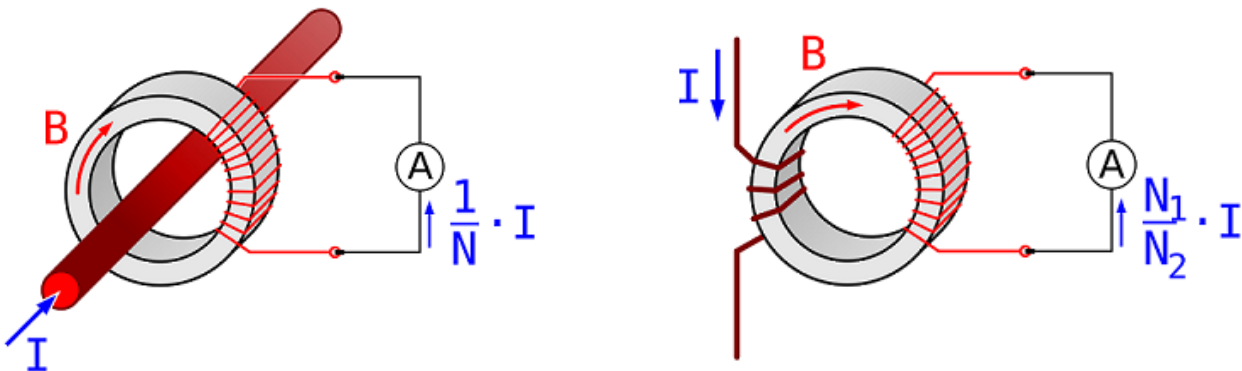

Fig. 14: Left: Principle of a ring-type CT; Right: Principle of a coil current transformer

#### ⚠ WARNING

##### Dangerous voltages if the secondary side is not connected

The secondary winding must be connected to an ammeter or short-circuited, otherwise high core losses or dangerous voltages may occur on the secondary side.

- Before replacing the measuring electronics in the secondary circuit, the current transformer must therefore be short-circuited at its secondary connections.

##### ● Grounding of secondary terminals

According to DIN VDE 0141 (01/2000) paragraph 5.3.4, current and voltage transformers for rated voltages from  $U_m = 3.6 \text{ kV}$  must be grounded on the secondary side. For low voltages ( $U_m \leq 1.2 \text{ kV}$ ), grounding is not required if the transformer housings do not have any metal surfaces with large contact areas.

### Small signal transformers with secondary signal voltage

In small signal transformers, the transformed secondary current of the current transformer is converted into a voltage signal via a low measuring resistance  $R_M$ . The input impedance  $R_V$  of the connected voltage electronics must be high-resistance and thus ensures a negligible influence on the measuring accuracy.

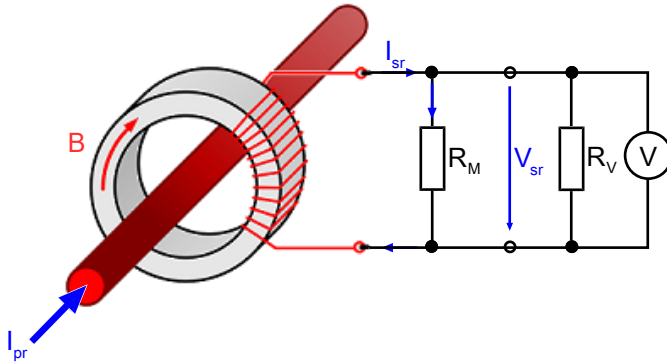

Fig. 15: Principle of a ring-type CT with secondary voltage signal

The low measuring resistance prevents dangerous open-circuit voltages, eliminating the need to short-circuit the secondary connections.

## 7.2 Technical terms of current transformers

Term	Explanation
<b>Primary rated current <math>I_{pr}</math></b> (alternative symbol $I_N$ )	Value of the rated current on the primary side
<b>Secondary rated current <math>I_{sr}</math></b>	Value of the rated current on the secondary side
<b>Secondary signal</b>	With low power transformers, a voltage signal in the mV range (e.g. 333 mV) is output using an internal load.
<b>Rated power <math>S_r</math></b>	Value of apparent power (in [VA]) that the transformer can deliver to the secondary circuit at secondary rated current and rated load
<b>Rated frequency <math>f_R</math></b>	Value of the rated frequency
<b>Accuracy class</b>	Indication that the measurement deviations are within specified limits under prescribed conditions of use.
<b>Rated insulation level <math>U_m</math></b>	Maximum voltage; the rms value of the highest phase-to-phase voltage for which a measuring transformer is rated in terms of its insulation. The value of the rated insulation level is specified in 3° increments: <ol style="list-style-type: none"> <li>1. maximum value of the conductor-to-conductor voltage for which the insulation of the transformers is designed;</li> <li>2. Value of the rated short-duration power frequency withstand voltage (50 Hz, 1 min), with which the insulation safety of the devices is tested</li> <li>3. Value of the surge voltage level (this specification is mostly unoccupied here, since according to IEC 61869/1 a specification is only required for transformers with a conductor-to-conductor voltage of &gt; 1.2 kV)</li> </ol>
<b>Overcurrent limiting factor (FS)</b>	Ratio of rated limiting current to primary rated current.
<b>Rated continuous thermal current <math>I_{cth}</math></b>	Value of the continuous current in the primary winding at which the overtemperature does not exceed the value specified in the standard, with the secondary winding loaded with the rated load.
<b>Rated short-time thermal current <math>I_{th}</math></b>	Value of short-time current for a limited time in the primary winding at which the overtemperature does not exceed the value specified in the standard, with the secondary winding loaded with the rated load.
<b>Rated peak current <math>I_{dyn}</math></b>	Maximum value of the primary current whose electromagnetic force effect does not cause electrical and mechanical damage to the current transformer with short-circuited secondary winding.
<b>“Open-circuit voltage” of low power current transformers</b> (e.g. SCL transformer with 333 mV secondary signal)	Due to the low measuring resistance, there is no dangerous “open-circuit voltage” with low power transformers. It is therefore not necessary to short-circuit the secondary terminals.
<b>“Open-circuit voltage” of typical current transformers</b> (e.g. SCT transformers with 1 A and 5 A secondary signal)	<b>WARNING</b> Current transformers which are not directly connected to a load must be short-circuited on the secondary side for safety reasons!  A current transformer operated open on the secondary side induces very high peak voltage values at its secondary terminals. The magnitudes of these voltages can reach values of up to several kilovolts, depending on the dimensioning of the current transformer, and thus represent a danger to persons and the functional safety of the transformer. For safety reasons, open operation should generally be avoided in order to prevent magnetization of the core iron during secondary open operation.
<b>Grounding of secondary terminals</b>	According to DIN VDE 0141 (01/2000) paragraph 5.3.4, current and voltage transformers for rated voltages from $U_m = 3.6$ kV must be earthed on the secondary side. For low voltage ( $U_m \leq 1.2$ kV), grounding is not required if the transformer housings do not have any metal surfaces that can be touched over a large area.

## 8 Notes on the class accuracy of current transformers

Current transformers are divided into classes according to their accuracy. Depending on the product category, Beckhoff current transformers are available in the standard accuracy classes 0.5; 1 and 3. The class designation corresponds to an error curve with regard to current amplitude and angle error. Beckhoff current transformers conform to the IEC 61869 standard.

The accuracy classes of current transformers are related to the rated current. If current transformers are operated with a low current in relation to the rated current, the measuring accuracy decreases. The following tables show the error limits taking into account the rated current values:

Percentage current error (±) when the operating current is a percentage of the rated current						
$I/I_N$ [%]		5 %	20 %	50 %	100 %	120 %
Accuracy class	0.5	1.5 %	0.75 %	-	0.5 %	0.5 %
	1	3.0 %	1.5 %	-	1.0 %	1.0 %
	3	-	-	3 %	-	3 %

Phase shift/misalignment (±) with percentage of operating current to rated current											
$I/I_N$ [%]		Minutes [ ' ]					Degrees				
		5 %	20 %	50 %	100 %	120 %	5 %	20 %	50 %	100 %	120 %
Accuracy class	0.5	90'	45'	-	30'	30'	1.5°	0.75°	-	0.5°	0.5°
	1	180'	90'	-	60'	60'	3°	1.5°	-	1°	1°
	3	-	-	-	-	-	-	-	-	-	-

The following graph shows the error limits taking into account the rated current values for the accuracy classes.

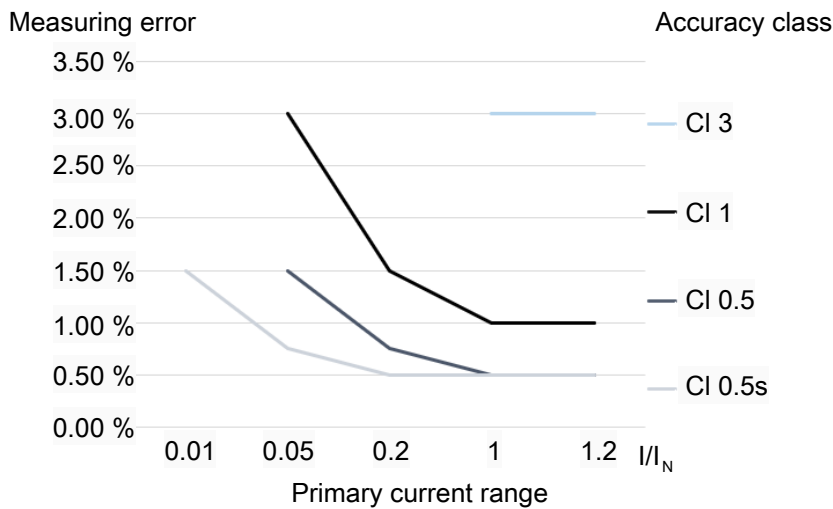

Fig. 16: Characteristic curves accuracy classes/primary current



### Transformer load

In order to use the optimum accuracy of the transformer, you must ensure that the cabling between the transformer and the measuring terminal provides a suitable transformer load in your application. This is achieved by using 0.25 to 1.0 times the rated power of the transformer. Additional resistors in the secondary path allow the transformer and measuring terminal to be adapted to each other.

## 9 Mounting and wiring

### ⚠ DANGER

#### Dangerous electrical voltage leads to electric shock and arc flashover!

Non-compliance will result in death, personal injury or considerable material damage!  
Ensure a safe working environment during assembly, maintenance and installation work

- Before beginning any assembly, maintenance, or installation work, disconnect the system from the power supply!
- Interrupt the power supply of the primary conductor and secure against being switched on again inadvertently.
- Make sure that the details on the nameplate and in the “Technical data” correspond to the operating parameters of the system.

#### Mounting the transformer housing on the primary conductor

1. Open the current transformer and attach it to the primary conductor.
  - For the correct assignment of the individual conductors, please note the numbering on the front of the individual split-core transformer housings
  - The direction of energy flow is marked on the side of the housing in the direction of the arrow from K (pointing to the source) to L (pointing to the loads). The labeling is located for
    - SCL60xx (size 1): on the underside
    - SCL61xx (size 2) on the contact surface of the primary conductor
    - SCL62xx, SCL63xx (sizes 3 and 4) on the mounting lugs for the primary conductor

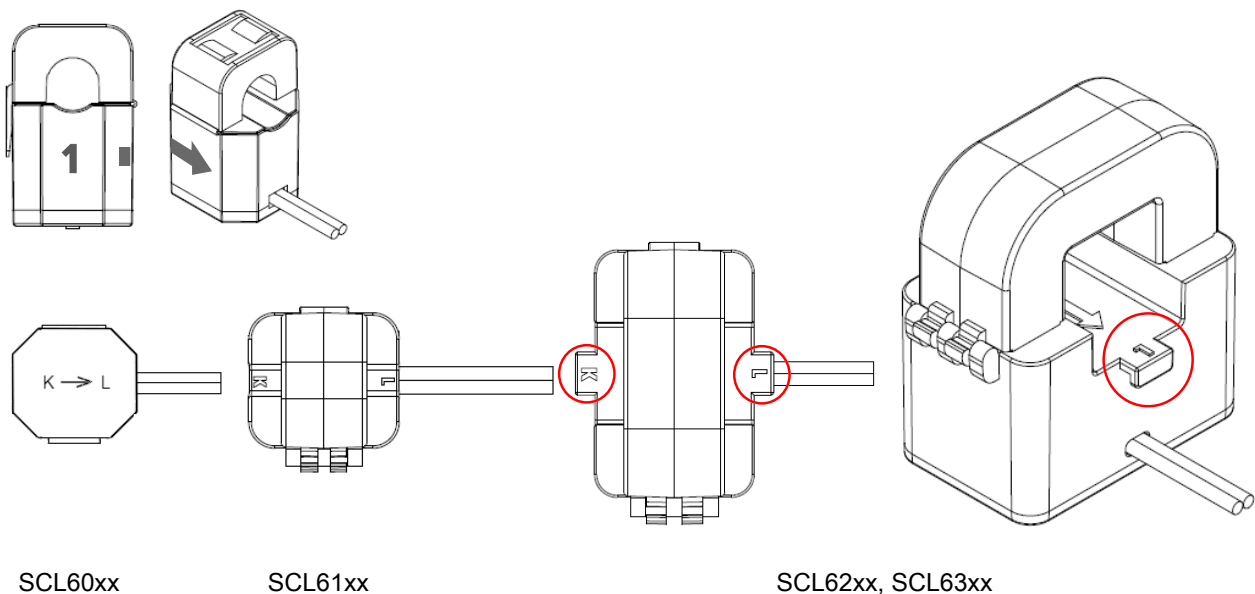

Fig. 17: Marking of conductor and energy flow direction, fixing lugs for primary conductors

2. Attach the SCL62xx and SCL63xx split-core transformer additionally with cable ties to the fastening straps (see fig. above) on the front and rear side of the housing. This avoids mechanical loading of the core by the primary conductor and the resulting measurement uncertainty.

### ⚠ CAUTION

#### Avoid soiling and moisture!

Make sure that the cut surfaces of the split-core are free of dirt and dry. Avoid hand contact (sweat)! Any type of contamination increases the measurement uncertainty.

3. Close the split-core transformer – press together until the closure engages.
4. Check that the split-core transformer is fitted correctly.

**Connection of the measuring unit**

1. Connect the connection housing of the transformers to the measuring unit for distributed power measurement (e.g. EL3475, EL3475-xxxx) via:
  - the pre-assembled sensor cable ZK2003-91D1-3xxx, shielded, PVC, 4 x 2 AWG26, for fixed installation, gray,
  - the EtherCAT connector C9900-K938, an 8-pin EtherCAT cable and an application-specific connector.

**i Note on connecting the measuring unit**

We recommend connection via the pre-assembled sensor cable,

- as this connection enables quick and easy assembly and disassembly and
  - the contact is completely protected against contact (dust-tight) and moisture via this connection in accordance with protection rating IP65/67.
- ⇒ Alternative connection options for laboratory operation are possible (see Alternative connection options for laboratory operation [▶ 38]).

2. To do this, insert the RJ45 plug of the connection cable into the RJ45 socket of the transformer housing so that the arrows printed on it match and push the plug into the socket until it audibly clicks into place.

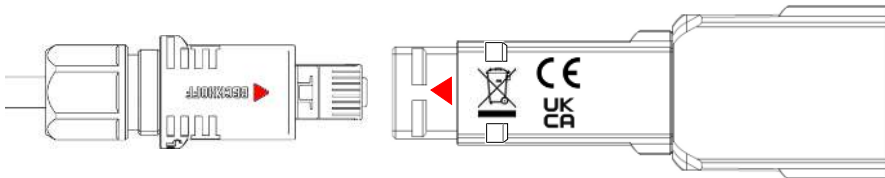

Fig. 18: Connect the secondary side of the transformer to the measuring unit

3. Also lock the connection with the red locking ring on the connector housing.

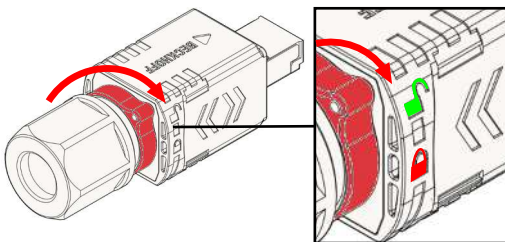

Fig. 19: Locking the connection to the measuring unit

### Alternative connection option for laboratory operation

- an 8-pin standard EtherCAT cable with RJ45 plugs (e.g. ZK1093-9191-0xxx).  
The connection housing of the transformers is designed so that most standard RJ45 plugs snap into the housing.
  - Make sure that the RJ45 plug is securely engaged in the connection housing of the transformer!
  - A small screwdriver is required for disassembly (e.g. ZB8701).

You can use the position of the latching lug to determine whether the plug snaps into the connection housing:

- Latching lug outside the flexible cover:
  - Plug snaps into the connection housing
- Latching lug inside the flexible cover:
  - Plug **does not** engage in the connection housing.

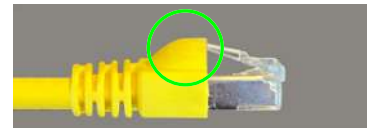

### NOTICE

#### Alternative connection option for laboratory operation only

The solution described above is suitable for laboratory use and is not recommended for industrial environments.

- Please note that tool-free disassembly is no longer possible after engaging!

### Mounting the transformer on the mounting rail

The SCLxxx/SVLxxx transformers can be attached to the mounting rail using the ZB8201-0900 snap-on mounting.

1. Screw the snap-on mounting to the mounting surface or snap it onto the mounting rail. Note the correct direction - the arrows (see Fig. 1 below) point upwards.
2. To do this, first push the upper rigid end onto the mounting rail and then press the lower flexible end onto the mounting rail.
3. Insert the transformers with the primary connections facing downwards onto the mounting bracket so that the latching cams on the mounting rails engage audibly in the receptacles of the connection housing.

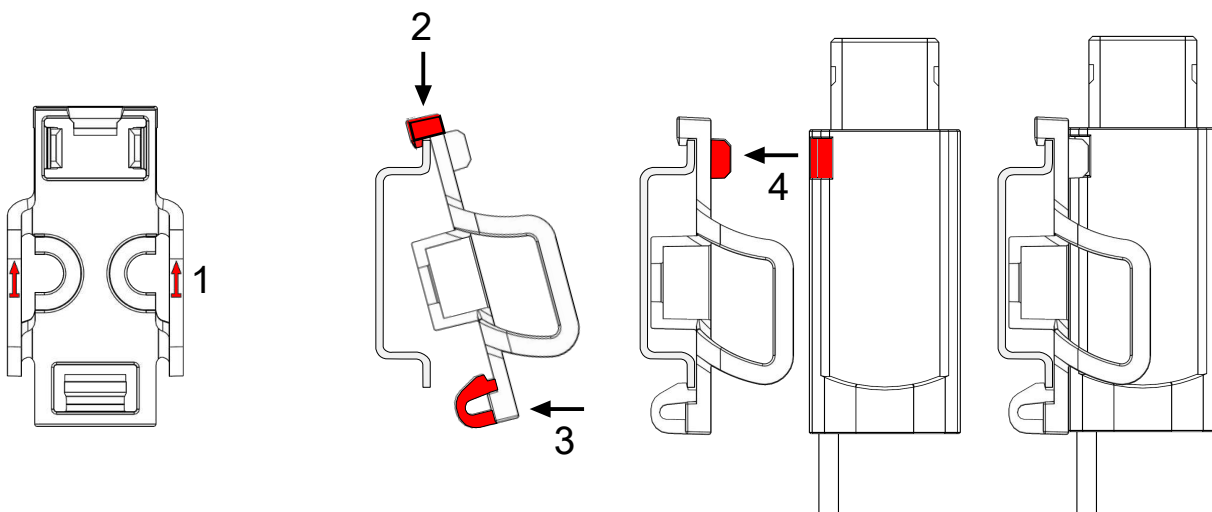

Fig. 20: Attaching the SCL/SVL transformers to the mounting rail using the ZB8201-0900 snap-on mounting

# 10 Commissioning

## 10.1 Maintenance, inspection and troubleshooting

### DANGER

#### **Dangerous electrical voltage leads to electric shock and arc flashover!**

Non-compliance will result in death, personal injury or considerable material damage!  
Ensure a safe working environment during assembly, maintenance and installation work

- Before beginning any assembly, maintenance, or installation work, disconnect the system from the power supply!
- Interrupt the power supply of the primary conductor and secure against being switched on again inadvertently.
- Make sure that the details on the nameplate and in the "Technical data" correspond to the operating parameters of the system.

#### **Maintenance and inspection**

- Check whether the secondary conductors are firmly connected to the measuring device.
- Check whether the current transformer is closed correctly.
- Remove coarse dirt from the housing of the current transformer.
- Contact with moisture, in particular with the core, must be avoided at all costs.

#### **Troubleshooting**

In the case of errors, e.g. unexpected or incorrect values, inverse power:

- Check the settings of the measuring device on the basis of its operating instructions.
- Check whether the current transformer is mounted on the intended conductor in the direction of the energy flow.
- Check the connection of the current transformers and the corresponding voltage tap-off if the active and/or reactive power does not correspond to the expected values; if necessary, one phase has been reversed.
- Check whether the current transformer is connected correctly.
- Check the power requirement of the conductors and measuring devices connected to the current transformer. It must not exceed the rated power of the current transformer (see name plate).
- If the above points do not solve the problem:  
Check whether there is dust or other dirt between the two parts of the core. If so, clean the surfaces carefully with a lint-free cloth.
- Avoid hand contact (sweat)!

## 10.2 Note on operation without electronic nameplate

If the electronic nameplate and the adjustment data it contains cannot be used, the deviating accuracy classes and measuring errors/uncertainties shown in the following table apply in addition to the technical data.

The following applies for operation without adjustment data:

Current transformer	Measuring error/uncertainty		Accuracy class
	Amplitude in % relative to full scale value	Phase in ° [degrees]	
SCL6023-0015	< ±0.50 %	< ±1.5°	3
SCL6023-0030	< ±0.50 %	< ±1°	1
SCL6023-0060	< ±0.50 %	< ±1°	1
SCL6023-0075	< ±0.50 %	< ±1°	1
SCL6123-0020	< ±0.50 %	< ±1.5°	3
SCL6123-0040	< ±0.50 %	< ±1.5°	3
SCL6123-0060	< ±0.50 %	< ±1.5°	3
SCL6223-0010	< ±0.50 %	< ±1.5°	3
SCL6223-0080	< ±0.50 %	< ±1°	1
SCL6223-0100	< ±0.50 %	< ±1°	1
SCL6323-0100	< ±0.50 %	< ±1°	1
SCL6323-0200	< ±0.50 %	< ±0.5°	0.5
SCL6323-0400	< ±0.50 %	< ±0.5°	0.5

# 11 Application example

## 11.1 Power measurement at a machine

**⚠ WARNING**

**Risk of injury from electric shock!**

Bring the bus terminal system into a safe, de-energized state before starting mounting, disassembly or wiring of the bus terminals!

**● Connection of low power split-core transformers with current and voltage interfaces**

**i** Both low power transformers with current and voltage interfaces can be connected to the RJ45 connections X1 - X4.

- When using small signal transformers from the SCL and SVL series, the transformer ratios are set automatically via the electronic nameplate.
- When using transformers without an electronic nameplate, manual configuration via the “modules/slots” procedure is required.

- The voltage is measured via a low power voltage transformer (e.g. from the Beckhoff SVL series) in the following example via the RJ45 connection X1.
- The current is measured by means of a low power split-core transformer, 3-channel current interface (e.g. from the Beckhoff SCL series) in the following example, the RJ45 connection X2.

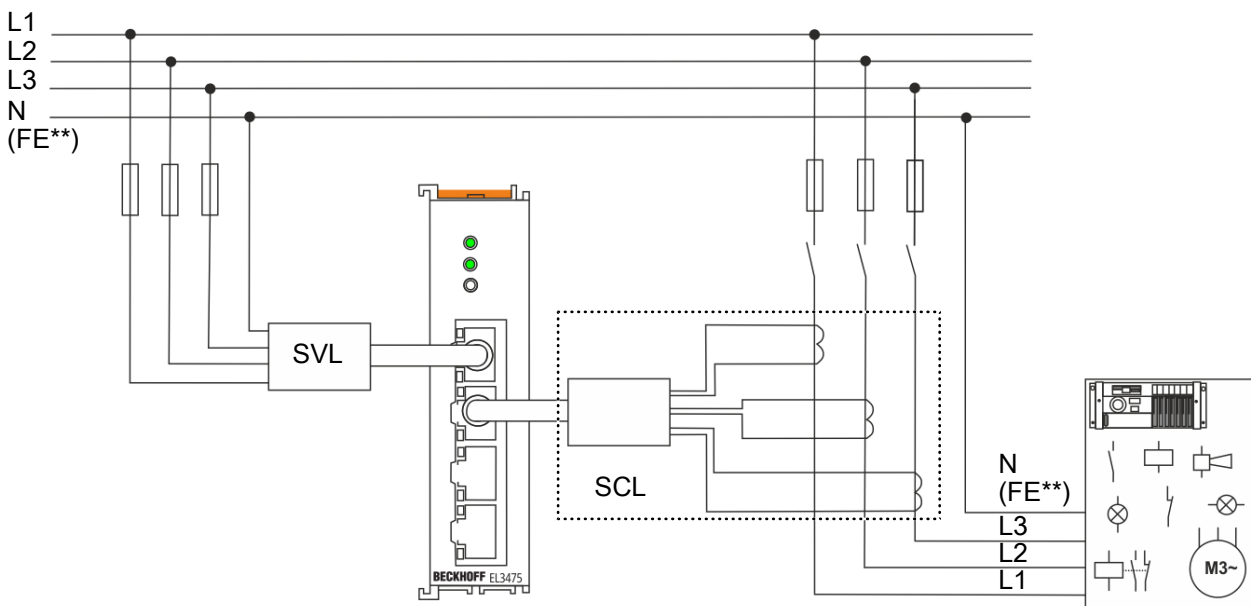

Fig. 21: Power measurement on a machine with EL3475 and low power transformers SCL and SVL

**● Terminal fuse protection**

- i**
- The voltage measurement inputs are high-resistance; a minimum measuring current flows. The protection for the SVL connections must therefore be applied in accordance with the conductor cross-section used.
  - For current measurement inputs, the fuse protection must be adapted by the device to be measured. The secondary currents of the transformers are no longer fused (see fig.)

**● \*\*) FE as star point for 3-phase systems without neutral conductor**

**i** Depending on the current transformer used, in 3-phase systems without a neutral conductor FE must be connected as a star point as shown in the figure above. Please observe the current transformer manufacturer's instructions!

---

**i** **Negative power values**

If negative power values are measured on a circuit, please check whether the associated current transformer circuit is connected correctly.

---

## 12 Appendix

### 12.1 Documentation issue status

Version	Comment
1.0.0	<ul style="list-style-type: none"><li>• First release for SCL6xxx</li></ul>
0.1	<ul style="list-style-type: none"><li>• Provisional documentation for SCL6xxx</li></ul>

## 12.2 Support and Service

Beckhoff and their partners around the world offer comprehensive support and service, making available fast and competent assistance with all questions related to Beckhoff products and system solutions.

### Beckhoff's branch offices and representatives

Please contact your Beckhoff branch office or representative for local support and service on Beckhoff products!

The addresses of Beckhoff's branch offices and representatives round the world can be found on her internet pages: [www.beckhoff.com](http://www.beckhoff.com)

You will also find further documentation for Beckhoff components there.

### Support

The Beckhoff Support offers you comprehensive technical assistance, helping you not only with the application of individual Beckhoff products, but also with other, wide-ranging services:

- support
- design, programming and commissioning of complex automation systems
- and extensive training program for Beckhoff system components

Hotline: +49 5246 963 157  
e-mail: [support@beckhoff.com](mailto:support@beckhoff.com)  
web: [www.beckhoff.com/support](http://www.beckhoff.com/support)

### Service

The Beckhoff Service Center supports you in all matters of after-sales service:

- on-site service
- repair service
- spare parts service
- hotline service

Hotline: +49 5246 963 460  
e-mail: [service@beckhoff.com](mailto:service@beckhoff.com)  
web: [www.beckhoff.com/service](http://www.beckhoff.com/service)

### Headquarters Germany

Beckhoff Automation GmbH & Co. KG

Hülshorstweg 20  
33415 Verl  
Germany

Phone: +49 5246 963 0  
e-mail: [info@beckhoff.com](mailto:info@beckhoff.com)  
web: [www.beckhoff.com](http://www.beckhoff.com)

## **Trademark statements**

Beckhoff®, ATRO®, EtherCAT®, EtherCAT G®, EtherCAT G10®, EtherCAT P®, MX-System®, Safety over EtherCAT®, TC/BSD®, TwinCAT®, TwinCAT/BSD®, TwinSAFE®, XFC®, XPlanar® and XTS® are registered and licensed trademarks of Beckhoff Automation GmbH.

More Information:  
[www.beckhoff.com/SCL6xxx](http://www.beckhoff.com/SCL6xxx)

Beckhoff Automation GmbH & Co. KG  
Hülshorstweg 20  
33415 Verl  
Germany  
Phone: +49 5246 9630  
[info@beckhoff.com](mailto:info@beckhoff.com)  
[www.beckhoff.com](http://www.beckhoff.com)

