

Documentation

KL5101

Incremental encoder interface

Version: 3.0.1
Date: 2018-04-30

BECKHOFF

Table of content

1 Foreword	5
1.1 Notes on the documentation	5
1.2 Safety instructions	6
1.3 Documentation Issue Status	7
2 Product overview	8
2.1 KL5101 - Introduction	8
2.2 KL5101 - Technical data	9
2.3 Basic Function Principles	10
3 Mounting and wiring	12
3.1 Instructions for ESD protection	12
3.2 Installation on mounting rails	12
3.3 Installation instructions for enhanced mechanical load capacity	16
3.4 Connection	16
3.4.1 Connection system	16
3.4.2 Wiring	18
3.4.3 Shielding	19
3.5 ATEX - Special conditions (extended temperature range)	20
3.6 ATEX Documentation	21
4 Configuration Software KS2000	22
4.1 KS2000 - Introduction	22
5 Access from the user program	24
5.1 KL5101 - Terminal configuration	24
5.2 Mapping in the Bus Coupler	26
5.2.1 Standard format	26
5.3 Register overview	27
5.4 Register description	27
5.5 Control and status byte	30
5.5.1 Process data exchange	30
5.5.2 Register communication	31
5.6 Examples of Register Communication	33
5.6.1 Example 1: reading the firmware version from Register 9	33
5.6.2 Example 2: Writing to an user register	33
6 Appendix	36
6.1 Support and Service	36

1 Foreword

1.1 Notes on the documentation

Intended audience

This description is only intended for the use of trained specialists in control and automation engineering who are familiar with the applicable national standards.

It is essential that the documentation and the following notes and explanations are followed when installing and commissioning these components.

It is the duty of the technical personnel to use the documentation published at the respective time of each installation and commissioning.

The responsible staff must ensure that the application or use of the products described satisfy all the requirements for safety, including all the relevant laws, regulations, guidelines and standards.

Disclaimer

The documentation has been prepared with care. The products described are, however, constantly under development.

We reserve the right to revise and change the documentation at any time and without prior announcement.

No claims for the modification of products that have already been supplied may be made on the basis of the data, diagrams and descriptions in this documentation.

Trademarks

Beckhoff®, TwinCAT®, EtherCAT®, Safety over EtherCAT®, TwinSAFE®, XFC® and XTS® are registered trademarks of and licensed by Beckhoff Automation GmbH.

Other designations used in this publication may be trademarks whose use by third parties for their own purposes could violate the rights of the owners.

Patent Pending

The EtherCAT Technology is covered, including but not limited to the following patent applications and patents: EP1590927, EP1789857, DE102004044764, DE102007017835 with corresponding applications or registrations in various other countries.

The TwinCAT Technology is covered, including but not limited to the following patent applications and patents: EP0851348, US6167425 with corresponding applications or registrations in various other countries.

The logo for EtherCAT, featuring the word "EtherCAT" in a bold, sans-serif font. A red arrow points from the top of the "A" towards the right, ending above the "T". A registered trademark symbol (®) is located to the right of the "T".

EtherCAT® is registered trademark and patented technology, licensed by Beckhoff Automation GmbH, Germany

Copyright

© Beckhoff Automation GmbH & Co. KG, Germany.

The reproduction, distribution and utilization of this document as well as the communication of its contents to others without express authorization are prohibited.

Offenders will be held liable for the payment of damages. All rights reserved in the event of the grant of a patent, utility model or design.

1.2 Safety instructions

Safety regulations

Please note the following safety instructions and explanations!
Product-specific safety instructions can be found on following pages or in the areas mounting, wiring, commissioning etc.

Exclusion of liability





All the components are supplied in particular hardware and software configurations appropriate for the application. Modifications to hardware or software configurations other than those described in the documentation are not permitted, and nullify the liability of Beckhoff Automation GmbH & Co. KG.

Personnel qualification

This description is only intended for trained specialists in control, automation and drive engineering who are familiar with the applicable national standards.

Description of symbols

In this documentation the following symbols are used with an accompanying safety instruction or note. The safety instructions must be read carefully and followed without fail!

 DANGER	<p>Serious risk of injury! Failure to follow the safety instructions associated with this symbol directly endangers the life and health of persons.</p>
 WARNING	<p>Risk of injury! Failure to follow the safety instructions associated with this symbol endangers the life and health of persons.</p>
 CAUTION	<p>Personal injuries! Failure to follow the safety instructions associated with this symbol can lead to injuries to persons.</p>
 Attention	<p>Damage to the environment or devices Failure to follow the instructions associated with this symbol can lead to damage to the environment or equipment.</p>
 Note	<p>Tip or pointer This symbol indicates information that contributes to better understanding.</p>

1.3 Documentation Issue Status

Version	Comment
3.0.1	<ul style="list-style-type: none"> • Translation correction
3.0	<ul style="list-style-type: none"> • Migration • Structure update

Firmware (FW) and hardware (HW) versions

Documentation, version	KL5101	
	FW	HW
3.0	5B	15

The firmware and hardware versions (delivery state) of the terminal can be found in the serial number printed on the side.

Syntax of the serial number

Structure of the serial number: WW YY FF HH

WW - week of production (calendar week)

YY - year of production

FF - firmware version

HH - hardware version

Example with ser. no.: 35 04 1B 01:

35 - week of production 35

4 - year of production 2004

1B - firmware version 1B

1 - hardware version 1

2 Product overview

2.1 KL5101 - Introduction

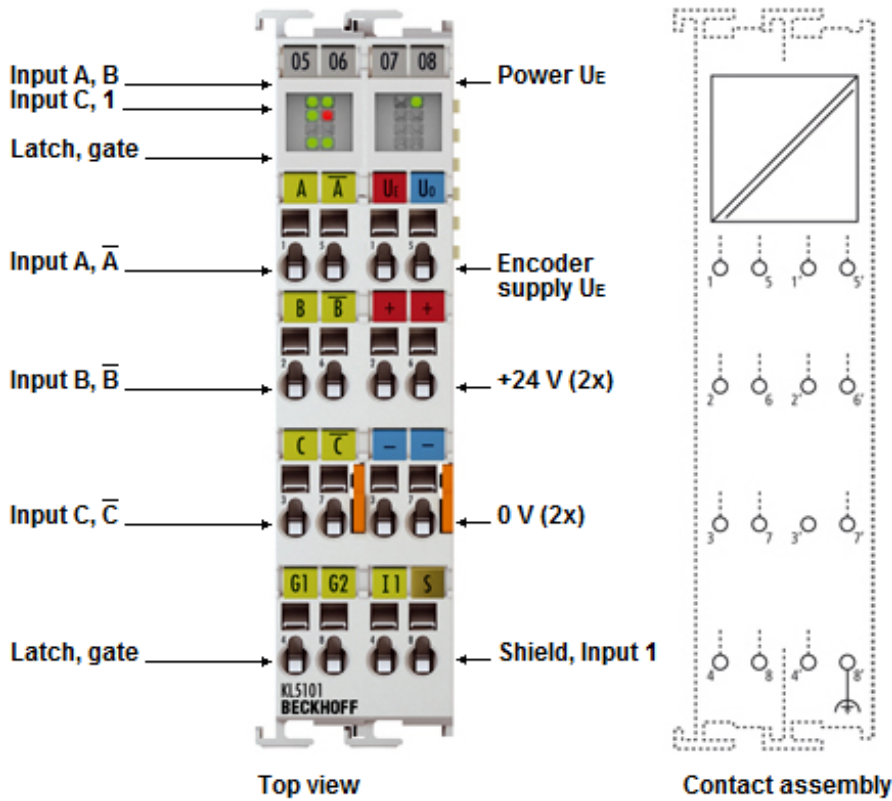

Fig. 1: KL5101

Incremental encoder interface

The KL5101 terminal is an interface for direct connection of incremental encoders with difference signal (RS422) or single inputs. A 16-bit counter with a quadrature decoder and a 16-bit latch for the zero pulse can be read, set or enabled. Incremental encoders with alarm outputs can be connected at the interface's status input. Period duration measurement with a resolution of 200 ns is possible. The G2 input allows the counter to be halted (high = stop), and the value is read with a positive edge at G1.

2.2 KL5101 - Technical data

Technical data	KL5101
Encoder connection	A, A(inv), B, B(inv), Null, Null(inv) Differential inputs (RS485), status input
Encoder operating voltage	5 V _{DC}
Encoder output current	0.5 A
Counter	16 bit, binary
Limit frequency	4 million increments/s (with 4-fold evaluation)
Quadrature decoder	1, 2, or 4-fold evaluation
Zero-pulse latch	16 bit
Commands	read, set, enable
Power supply	24 V _{DC} (-15 %/+20 %)
Supply voltage	24 V _{DC} (-15 %/+20 %)
Current consumption power contacts	- (no power contacts)
Current consumption K-bus	typ. 60 mA
Bit width in process image	Input: 1 x 16 bit data, 1 x 8 bit control/status
Weight	approx. 85 g
Permissible ambient temperature range during operation	-25°C ... + 60°C (extended temperature range)
Permissible ambient temperature range during storage	-40°C ... + 85°C
Permissible relative air humidity	95 %, no condensation
Vibration / shock resistance	conforms to EN 60068-2-6 / EN 60068-2-27, see also Installation instructions for enhanced mechanical load capacity [►_16]
EMC immunity / emission	conforms to EN 61000-6-2 / EN 61000-6-4
Protection class	IP20
Installation position	variable
Approval	CE, cULus, ATEX [►_20]

2.3 Basic Function Principles

The KL5101 incremental encoder interface terminal enables the connection of any incremental encoder to the Bus Coupler or PLC. A 16-bit counter with a quadrature decoder and a 16-bit latch can be read, set or enabled. In addition to the encoder inputs A, B and C, an additional latch input G1 (24 V) and a gate input G2 (24 V) for locking the counter are available.

It is also possible for the 16-bit up/down counter operating mode to be selected. In this mode, input B is the counter input.

1, 2, or 4-fold evaluation of the encoder signals A, B, C in simple or complementary form can be parameterized via the fieldbus.

The terminal is supplied as a 4-fold quadrature decoder with complementary evaluation of the sensor signals A, B, C. To operate the encoder interface, the 24 V_{DC} operating voltage must be connected to the terminal contacts in addition to the encoder inputs.

From hardware version 03 (i.e. from 18 June 1998) the KL5101 is delivered with new, additional features:

- If the incremental encoder has an alarm output, it can be connected to the status input of the KL5101.
- A period duration measurement with a resolution of 200 ns can also be carried out.

Operation modes

Can be set via the feature register (default setting incremental encoder):
A, B, zero pulse incremental encoder (default)

Up/down counter with:

- A = count; the positive edges of the input pulses are counted
- B = up/down input
 - B = 0: Up count direction
 - B = 1: Down count direction
- C = gate input
 - C = 0: Counter enabled
 - C = 1: Counter is locked

Functions

- Counting
- Set counter
- Activate zero pulse and save valid value
- Determination of the period duration between two pulses with a resolution of 200 ns (the time between two positive edges of input signal A is evaluated).
- Display of a counter overflow or underflow.

Process data

The KL5101 always occupies 6 bytes of input data and 6 bytes of output data. The control/status byte is located at the lowest byte offset. The data word D0/D1 contains the counter word (read/set), the data word D3/D4 contains the latch word (read). In period duration measurement mode, the period duration is output in D2 together with D3/D4.

LED display

The signal LEDs indicate the states of the encoder inputs A, B, C and the status input, as well as the state of the logic inputs of the gate and the additional external latch. The RUN LED indicates cyclic data exchange with the higher-level controller. If no process data is exchanged for 100 ms, the RUN LED goes out. The Power UE LED indicates the operating voltage for the power supply of the incremental encoder.

Connection

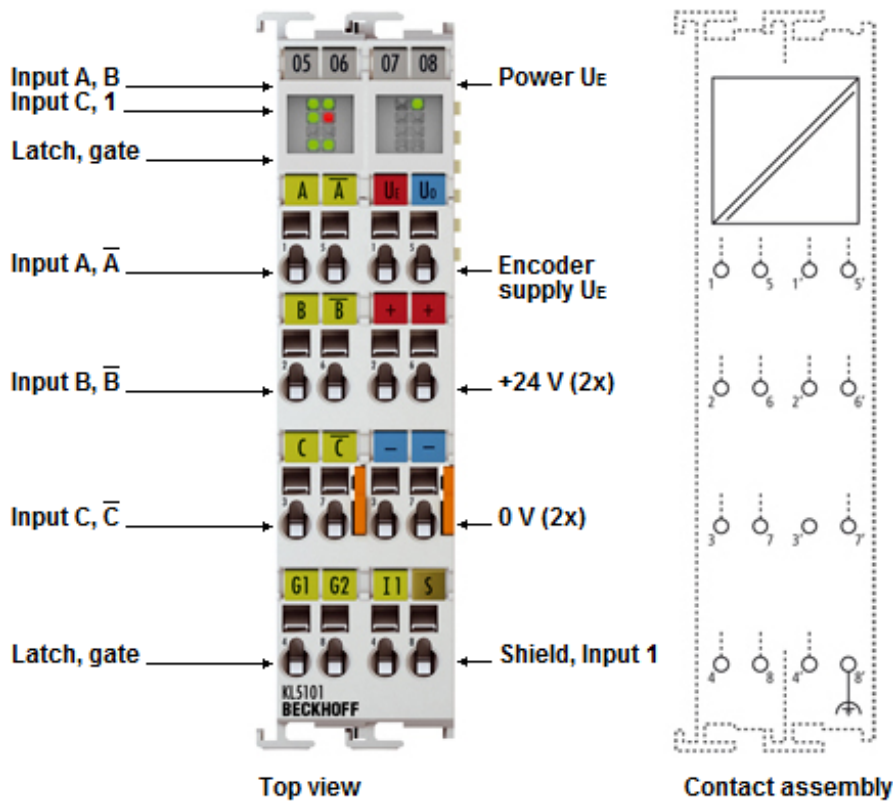



Fig. 2: Assignment of the terminal contacts

- **Inputs A, /A:** Pulse input in encoder and counter mode of the terminal.
- **Inputs B, /B:** Phase-shifted pulse input in encoder mode of the terminal.
- **Counting direction input in counter mode of the terminal:** Counting direction:
 - + 5 V (or open contact): up
 - 0 V: down
- **Inputs C, /C:** Zero point pulse input for the terminal's latch register. This input is activated via the EN_LATC bit in the control byte of the terminal.
- **External Latch 24 V:** Additional latch input of the terminal. This input is activated via the EN_LAT_EXT bit in the control byte of the terminal. If this input is enabled, the counter value will be latched when the edge changes from 0 V to 24 V.
- **External Gate 24 V:** A high level at this contact suppresses counting by the terminal.
- **Status Input:** If the incremental encoder has an alarm output, it can be connected to the status input (active low input with internal pull-up circuitry).
- **U_e :** Power supply for the encoder (+5 V).
- **U_o :** Power supply for the encoder (0 V).
- **0 V, 24 V:** A voltage supply of 0 V and 24 V must be connected to these contacts for operation of the terminal.

3 Mounting and wiring

3.1 Instructions for ESD protection

	<p>Destruction of the devices by electrostatic discharge possible!</p> <p>The devices contain components at risk from electrostatic discharge caused by improper handling.</p> <ul style="list-style-type: none"> ✓ Please ensure you are electrostatically discharged and avoid touching the contacts of the device directly. a) Avoid contact with highly insulating materials (synthetic fibers, plastic film etc.). b) Surroundings (working place, packaging and personnel) should be grounded probably, when handling with the devices. c) Each assembly must be terminated at the right hand end with an EL9011 bus end cap, to ensure the protection class and ESD protection.
<p>Attention</p>	

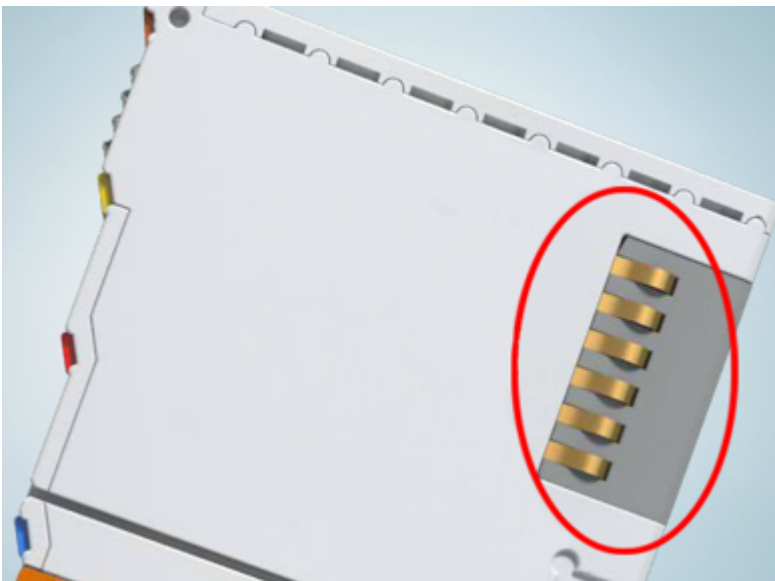



Fig. 3: Spring contacts of the Beckhoff I/O components

3.2 Installation on mounting rails

	<p>Risk of electric shock and damage of device!</p> <p>Bring the bus terminal system into a safe, powered down state before starting installation, disassembly or wiring of the Bus Terminals!</p>
<p>WARNING</p>	

Assembly

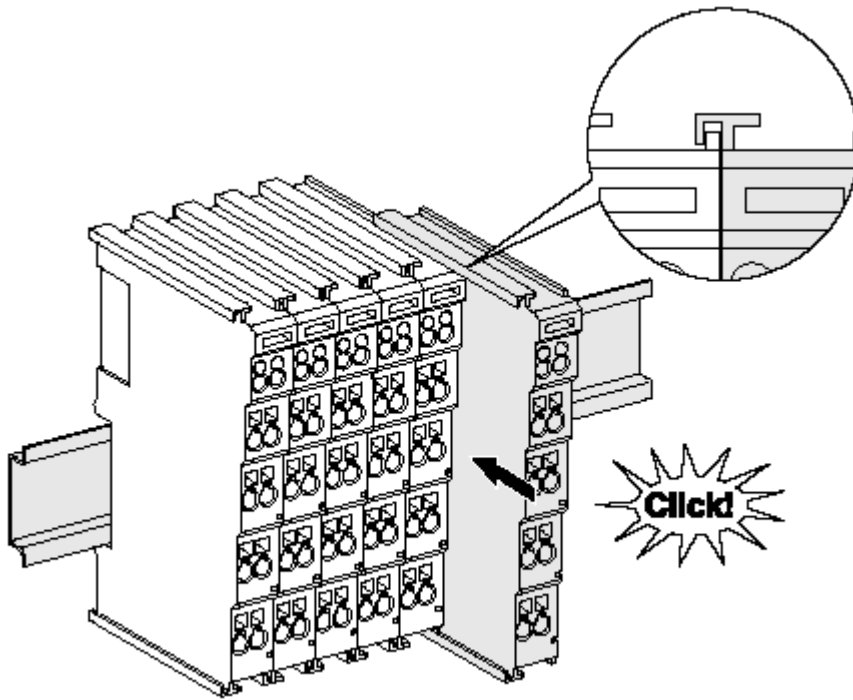

Fig. 4: Attaching on mounting rail

The Bus Coupler and Bus Terminals are attached to commercially available 35 mm mounting rails (DIN rails according to EN 60715) by applying slight pressure:

1. First attach the Fieldbus Coupler to the mounting rail.
2. The Bus Terminals are now attached on the right-hand side of the Fieldbus Coupler. Join the components with tongue and groove and push the terminals against the mounting rail, until the lock clicks onto the mounting rail.

If the Terminals are clipped onto the mounting rail first and then pushed together without tongue and groove, the connection will not be operational! When correctly assembled, no significant gap should be visible between the housings.



Note

Fixing of mounting rails

The locking mechanism of the terminals and couplers extends to the profile of the mounting rail. At the installation, the locking mechanism of the components must not come into conflict with the fixing bolts of the mounting rail. To mount the mounting rails with a height of 7.5 mm under the terminals and couplers, you should use flat mounting connections (e.g. countersunk screws or blind rivets).

Disassembly

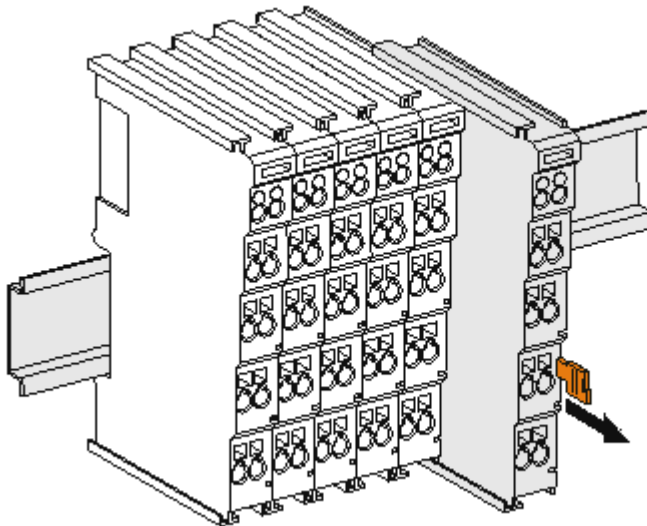

Fig. 5: Disassembling of terminal

Each terminal is secured by a lock on the mounting rail, which must be released for disassembly:

1. Pull the terminal by its orange-colored lugs approximately 1 cm away from the mounting rail. In doing so for this terminal the mounting rail lock is released automatically and you can pull the terminal out of the bus terminal block easily without excessive force.
2. Grasp the released terminal with thumb and index finger simultaneous at the upper and lower grooved housing surfaces and pull the terminal out of the bus terminal block.

Connections within a bus terminal block

The electric connections between the Bus Coupler and the Bus Terminals are automatically realized by joining the components:

- The six spring contacts of the K-Bus/E-Bus deal with the transfer of the data and the supply of the Bus Terminal electronics.
- The power contacts deal with the supply for the field electronics and thus represent a supply rail within the bus terminal block. The power contacts are supplied via terminals on the Bus Coupler (up to 24 V) or for higher voltages via power feed terminals.



Note

Power Contacts

During the design of a bus terminal block, the pin assignment of the individual Bus Terminals must be taken account of, since some types (e.g. analog Bus Terminals or digital 4-channel Bus Terminals) do not or not fully loop through the power contacts. Power Feed Terminals (KL91xx, KL92xx or EL91xx, EL92xx) interrupt the power contacts and thus represent the start of a new supply rail.

PE power contact

The power contact labeled PE can be used as a protective earth. For safety reasons this contact mates first when plugging together, and can ground short-circuit currents of up to 125 A.

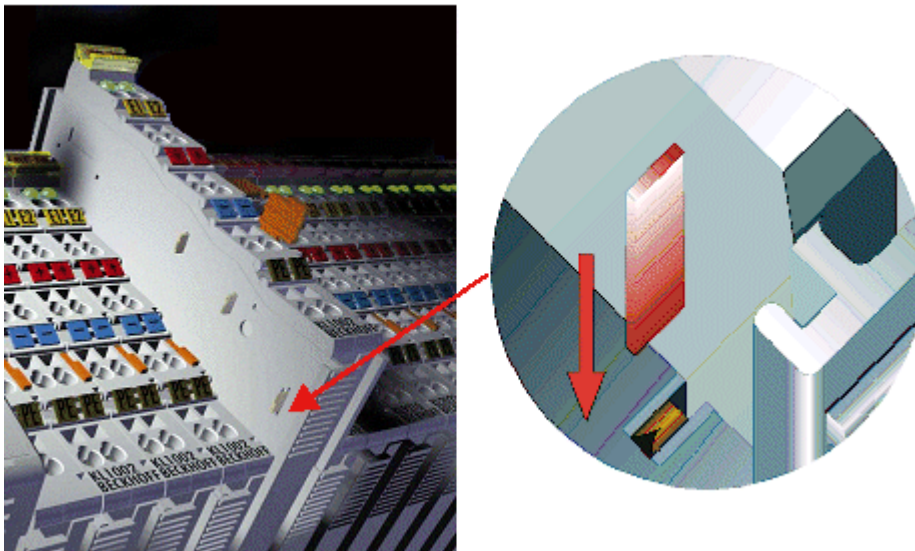



Fig. 6: Power contact on left side

	<p>Possible damage of the device</p>
<p>Attention</p>	<p>Note that, for reasons of electromagnetic compatibility, the PE contacts are capacitatively coupled to the mounting rail. This may lead to incorrect results during insulation testing or to damage on the terminal (e.g. disruptive discharge to the PE line during insulation testing of a consumer with a nominal voltage of 230 V). For insulation testing, disconnect the PE supply line at the Bus Coupler or the Power Feed Terminal! In order to decouple further feed points for testing, these Power Feed Terminals can be released and pulled at least 10 mm from the group of terminals.</p>
	<p>Risk of electric shock!</p>
<p>WARNING</p>	<p>The PE power contact must not be used for other potentials!</p>

3.3 Installation instructions for enhanced mechanical load capacity

 WARNING	<p>Risk of injury through electric shock and damage to the device!</p> <p>Bring the Bus Terminal system into a safe, de-energized state before starting mounting, disassembly or wiring of the Bus Terminals!</p>
---	--

Additional checks

The terminals have undergone the following additional tests:

Verification	Explanation
Vibration	10 frequency runs in 3 axes
	6 Hz < f < 60 Hz displacement 0.35 mm, constant amplitude
	60.1 Hz < f < 500 Hz acceleration 5 g, constant amplitude
Shocks	1000 shocks in each direction, in 3 axes
	25 g, 6 ms

Additional installation instructions

For terminals with enhanced mechanical load capacity, the following additional installation instructions apply:

- The enhanced mechanical load capacity is valid for all permissible installation positions
- Use a mounting rail according to EN 60715 TH35-15
- Fix the terminal segment on both sides of the mounting rail with a mechanical fixture, e.g. an earth terminal or reinforced end clamp
- The maximum total extension of the terminal segment (without coupler) is:
64 terminals (12 mm mounting with) or 32 terminals (24 mm mounting with)
- Avoid deformation, twisting, crushing and bending of the mounting rail during edging and installation of the rail
- The mounting points of the mounting rail must be set at 5 cm intervals
- Use countersunk head screws to fasten the mounting rail
- The free length between the strain relief and the wire connection should be kept as short as possible. A distance of approx. 10 cm should be maintained to the cable duct.

3.4 Connection

3.4.1 Connection system

 WARNING	<p>Risk of electric shock and damage of device!</p> <p>Bring the bus terminal system into a safe, powered down state before starting installation, disassembly or wiring of the Bus Terminals!</p>
---	---

Overview

The Bus Terminal system offers different connection options for optimum adaptation to the respective application:

- The terminals of ELxxxx and KLxxxx series with standard wiring include electronics and connection level in a single enclosure.
- The terminals of ESxxxx and KSxxxx series feature a pluggable connection level and enable steady wiring while replacing.

- The High Density Terminals (HD Terminals) include electronics and connection level in a single enclosure and have advanced packaging density.

Standard wiring (ELxxxx / KLxxxx)

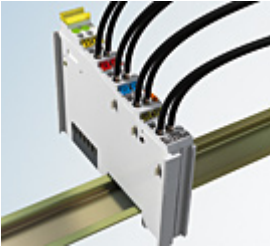

Fig. 7: Standard wiring

The terminals of ELxxxx and KLxxxx series have been tried and tested for years. They feature integrated screwless spring force technology for fast and simple assembly.

Pluggable wiring (ESxxxx / KSxxxx)

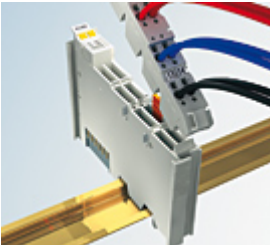

Fig. 8: Pluggable wiring

The terminals of ESxxxx and KSxxxx series feature a pluggable connection level. The assembly and wiring procedure is the same as for the ELxxxx and KLxxxx series. The pluggable connection level enables the complete wiring to be removed as a plug connector from the top of the housing for servicing. The lower section can be removed from the terminal block by pulling the unlocking tab. Insert the new component and plug in the connector with the wiring. This reduces the installation time and eliminates the risk of wires being mixed up.

The familiar dimensions of the terminal only had to be changed slightly. The new connector adds about 3 mm. The maximum height of the terminal remains unchanged.

A tab for strain relief of the cable simplifies assembly in many applications and prevents tangling of individual connection wires when the connector is removed.

Conductor cross sections between 0.08 mm² and 2.5 mm² can continue to be used with the proven spring force technology.

The overview and nomenclature of the product names for ESxxxx and KSxxxx series has been retained as known from ELxxxx and KLxxxx series.

High Density Terminals (HD Terminals)



Fig. 9: High Density Terminals

The Bus Terminals from these series with 16 terminal points are distinguished by a particularly compact design, as the packaging density is twice as large as that of the standard 12 mm Bus Terminals. Massive conductors and conductors with a wire end sleeve can be inserted directly into the spring loaded terminal point without tools.



Note

Wiring HD Terminals

The High Density (HD) Terminals of the ELx8xx and KLx8xx series doesn't support pluggable wiring.

Ultrasonically "bonded" (ultrasonically welded) conductors



Note

Ultrasonically "bonded" conductors

It is also possible to connect the Standard and High Density Terminals with ultrasonically "bonded" (ultrasonically welded) conductors. In this case, please note the tables concerning the wire-size width below!

3.4.2 Wiring



WARNING

Risk of electric shock and damage of device!

Bring the bus terminal system into a safe, powered down state before starting installation, disassembly or wiring of the Bus Terminals!

Terminals for standard wiring ELxxx/KLxxx and for pluggable wiring ESxxx/KSxxx

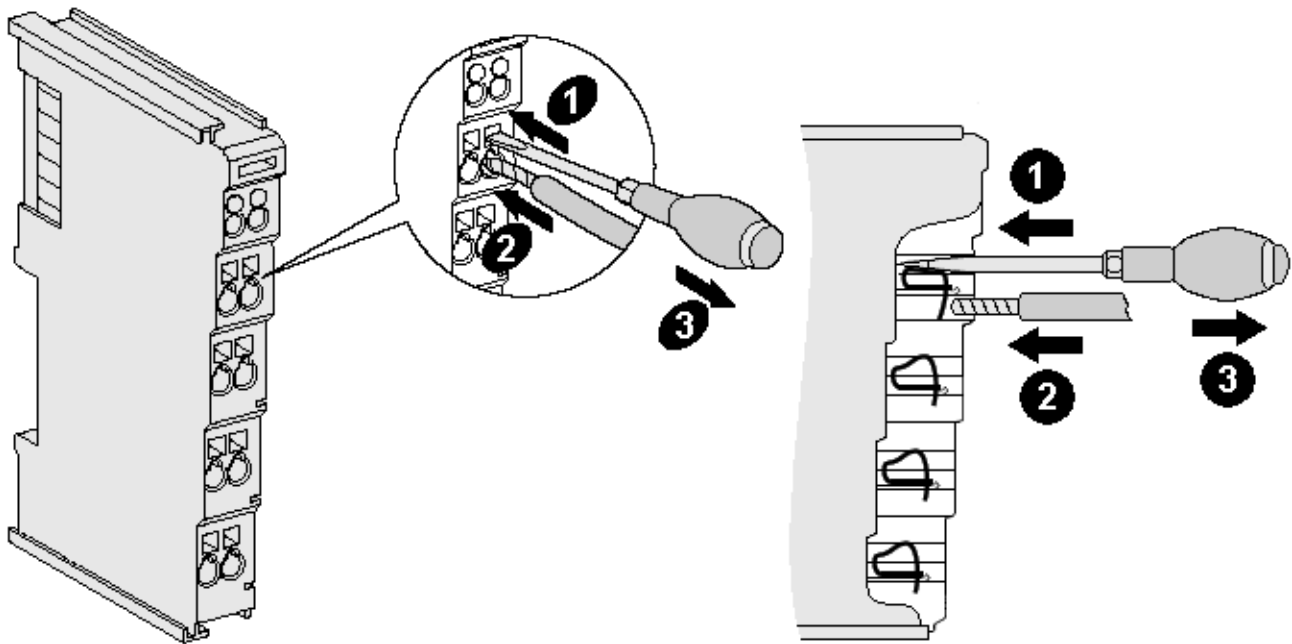

Fig. 10: Connecting a cable on a terminal point

Up to eight terminal points enable the connection of solid or finely stranded cables to the Bus Terminal. The terminal points are implemented in spring force technology. Connect the cables as follows:

1. Open a terminal point by pushing a screwdriver straight against the stop into the square opening above the terminal point. Do not turn the screwdriver or move it alternately (don't toggle).
2. The wire can now be inserted into the round terminal opening without any force.
3. The terminal point closes automatically when the pressure is released, holding the wire securely and permanently.

See the following table for the suitable wire size width.

Terminal housing	ELxxxx, KLxxxx	ESxxxx, KSxxxx
Wire size width (single core wires)	0.08 ... 2.5 mm ²	0.08 ... 2.5 mm ²
Wire size width (fine-wire conductors)	0.08 ... 2.5 mm ²	0,08 ... 2.5 mm ²
Wire size width (conductors with a wire end sleeve)	0.14 ... 1.5 mm ²	0.14 ... 1.5 mm ²
Wire stripping length	8 ... 9 mm	9 ... 10 mm

High Density Terminals ([HD Terminals \[► 17\]](#)) with 16 terminal points

The conductors of the HD Terminals are connected without tools for single-wire conductors using the direct plug-in technique, i.e. after stripping the wire is simply plugged into the terminal point. The cables are released, as usual, using the contact release with the aid of a screwdriver. See the following table for the suitable wire size width.

Terminal housing	High Density Housing
Wire size width (single core wires)	0.08 ... 1.5 mm ²
Wire size width (fine-wire conductors)	0.25 ... 1.5 mm ²
Wire size width (conductors with a wire end sleeve)	0.14 ... 0.75 mm ²
Wire size width (ultrasonically "bonded" conductors)	only 1.5 mm ²
Wire stripping length	8 ... 9 mm

3.4.3 Shielding



Note

Shielding

Encoder, analog sensors and actors should always be connected with shielded, twisted paired wires.

3.5 ATEX - Special conditions (extended temperature range)



WARNING

Observe the special conditions for the intended use of Beckhoff fieldbus components with extended temperature range (ET) in potentially explosive areas (directive 94/9/EU)!

- The certified components are to be installed in a suitable housing that guarantees a protection class of at least IP54 in accordance with EN 60529! The environmental conditions during use are thereby to be taken into account!
- If the temperatures during rated operation are higher than 70°C at the feed-in points of cables, lines or pipes, or higher than 80°C at the wire branching points, then cables must be selected whose temperature data correspond to the actual measured temperature values!
- Observe the permissible ambient temperature range of -25 to 60°C for the use of Beckhoff fieldbus components with extended temperature range (ET) in potentially explosive areas!
- Measures must be taken to protect against the rated operating voltage being exceeded by more than 40% due to short-term interference voltages!
- The individual terminals may only be unplugged or removed from the Bus Terminal system if the supply voltage has been switched off or if a non-explosive atmosphere is ensured!
- The connections of the certified components may only be connected or disconnected if the supply voltage has been switched off or if a non-explosive atmosphere is ensured!
- The fuses of the KL92xx/EL92xx power feed terminals may only be exchanged if the supply voltage has been switched off or if a non-explosive atmosphere is ensured!
- Address selectors and ID switches may only be adjusted if the supply voltage has been switched off or if a non-explosive atmosphere is ensured!

Standards

The fundamental health and safety requirements are fulfilled by compliance with the following standards:

- EN 60079-0:2012+A11:2013
- EN 60079-15:2010

Marking

The Beckhoff fieldbus components with extended temperature range (ET) certified for potentially explosive areas bear the following marking:



II 3G KEMA 10ATEX0075 X Ex nA IIC T4 Gc Ta: -25 ... 60°C

or



II 3G KEMA 10ATEX0075 X Ex nC IIC T4 Gc Ta: -25 ... 60°C

3.6 ATEX Documentation



Note

Notes about operation of the Beckhoff terminal systems in potentially explosive areas (ATEX)

Pay also attention to the continuative documentation

Notes about operation of the Beckhoff terminal systems in potentially explosive areas (ATEX)

that is available in the download area of the Beckhoff homepage <http://www.beckhoff.com>!

4 Configuration Software KS2000

4.1 KS2000 - Introduction

The KS2000 configuration software permits configuration, commissioning and parameterization of bus couplers, of the affiliated bus terminals and of Fieldbus Box Modules. The connection between bus coupler / Fieldbus Box Module and the PC is established by means of the serial configuration cable or the fieldbus.



Fig. 11: KS2000 configuration software

Configuration

You can configure the Fieldbus stations with the Configuration Software KS2000 offline. That means, setting up a terminal station with all settings on the couplers and terminals resp. the Fieldbus Box Modules can be prepared before the commissioning phase. Later on, this configuration can be transferred to the terminal station in the commissioning phase by means of a download. For documentation purposes, you are provided with the breakdown of the terminal station, a parts list of modules used and a list of the parameters you have modified. After an upload, existing fieldbus stations are at your disposal for further editing.

Parameterization

KS2000 offers simple access to the parameters of a fieldbus station: specific high-level dialogs are available for all bus couplers, all intelligent bus terminals and Fieldbus Box modules with the aid of which settings can be modified easily. Alternatively, you have full access to all internal registers of the bus couplers and intelligent terminals. Refer to the register description for the meanings of the registers.

Commissioning

The KS2000 software facilitates commissioning of machine components or their fieldbus stations: Configured settings can be transferred to the fieldbus modules by means of a download. After a *login* to the terminal station, it is possible to define settings in couplers, terminals and Fieldbus Box modules directly *online*. The same high-level dialogs and register access are available for this purpose as in the configuration phase.

The KS2000 offers access to the process images of the bus couplers and Fieldbus Box modules.

- Thus, the coupler's input and output images can be observed by monitoring.
- Process values can be specified in the output image for commissioning of the output modules.

All possibilities in the *online mode* can be used in parallel with the actual fieldbus mode of the terminal station. The fieldbus protocol always has the higher priority in this case.

5 Access from the user program

5.1 KL5101 - Terminal configuration

Each terminal channel is mapped in the Bus Coupler. Depending on the type of the Bus Coupler and the mapping configuration (e.g. Motorola/Intel format, word alignment etc.) the terminal data are mapped in different ways to the Bus Coupler memory.

In contrast to analog input and output terminals, the KL5101 always also maps the control and status byte, independently of the higher-level fieldbus system.

BK2000 Lightbus coupler

With the BK2000 Lightbus coupler, the control/status byte is always mapped in addition to the data bytes (i.e. for all analog terminals). This is always in the low byte on the offset address of the terminal channel.

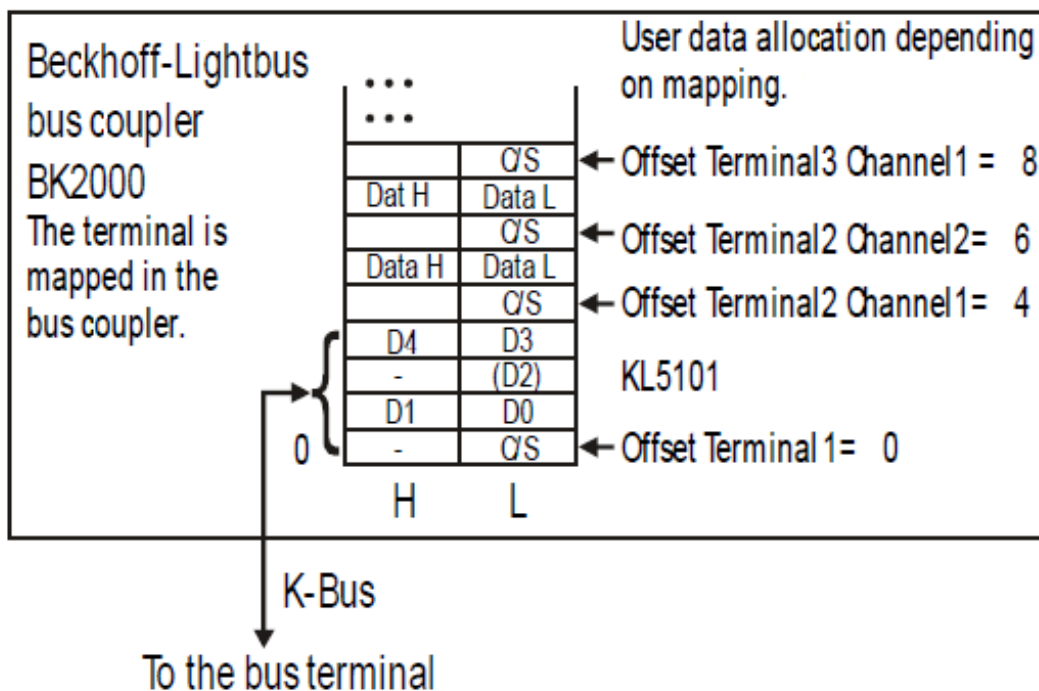

Fig. 12: Mapping for Lightbus Coupler - example for KL5101

BK3000 PROFIBUS coupler

In the BK3000 Profibus coupler, the KL5101 is always mapped with 6 bytes of input data and 6 bytes of output data.

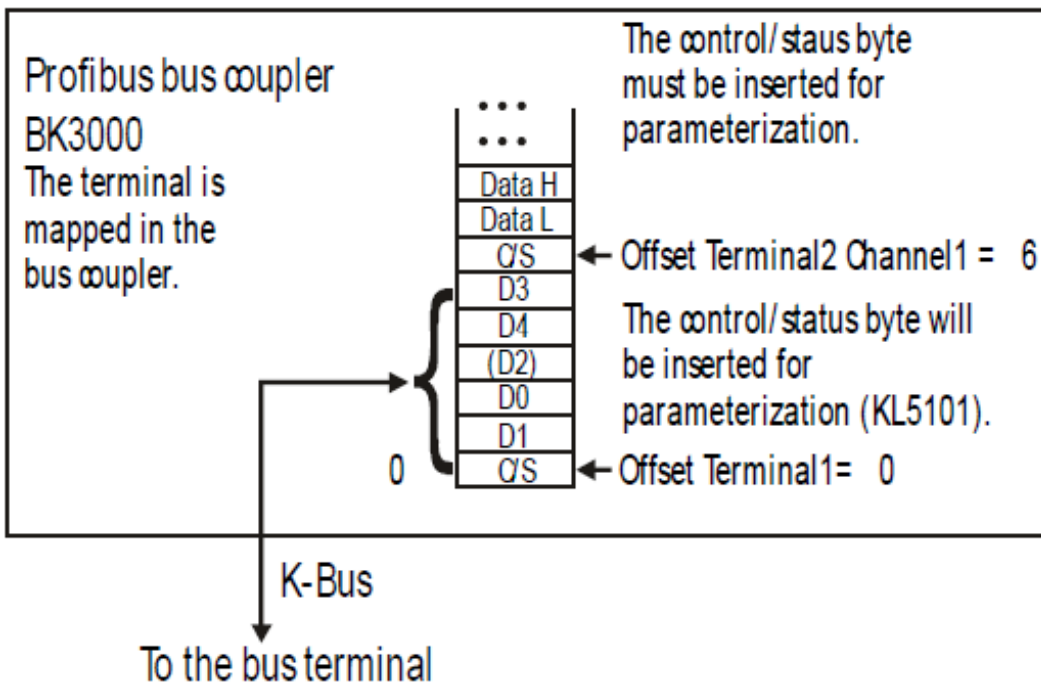

Fig. 13: Mapping for Profibus Coupler - example for KL5101

BK4000 Interbus Coupler

The BK4000 Interbus coupler normally maps the KL5101 with 6 bytes of input data and 6 bytes of output data.

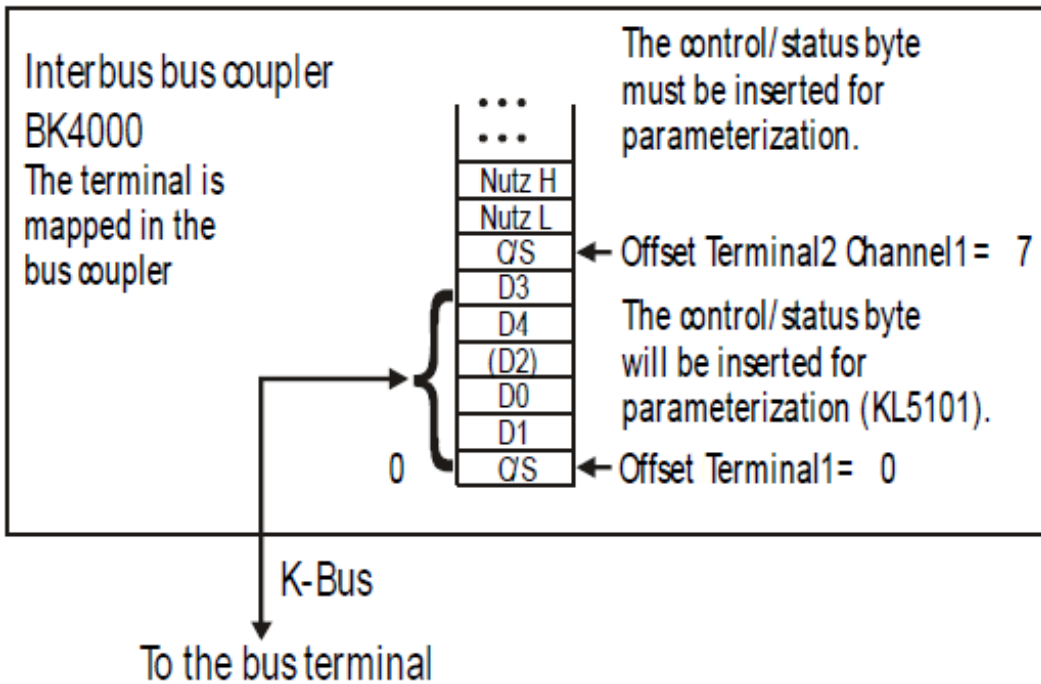

Fig. 14: Mapping for Interbus Coupler - example for KL5101

Other Bus Couplers and further information

Further information about the mapping configuration of Bus Couplers can be found in the Appendix of the respective Bus Coupler manual under *Master configuration*.

The chapter on Mapping in the Bus Coupler [▶ 26] contains an overview of possible mapping configurations, depending on the configurable parameters.

**Note****Parameterization with KS2000**

The KS2000 configuration software can be used for parameterizations via the serial interface of the Bus Coupler, independent of the fieldbus system.

5.2 Mapping in the Bus Coupler

As already described in the *Terminal Configuration* section, each Bus Terminal is mapped in the Bus Coupler. This mapping is usually done with the default setting in the Bus Coupler / Bus Terminal. The KS2000 configuration software or a master configuration software (e.g. ComProfibus or TwinCAT System Manager) can be used to change this default setting.

If the terminals are fully evaluated, they occupy memory space in the input and output process image.

The following tables provide information about how the terminals map themselves in the Bus Coupler, depending on the parameters set.

5.2.1 Standard format

The KL5101 is mapped into the bus coupler depending on the set parameters. The terminal always occupies memory space in the process image of the inputs **and** outputs.

Conditions	Word offset	High Byte	Low Byte
Complete evaluation: any	0	D0	CB/SB
Motorola format: no	1	D2	D1
Word alignment: no	2	D4	D3

Conditions	Word offset	High Byte	Low Byte
Complete evaluation: any	0	D1	CB/SB
Motorola format: yes	1	D2	D0
Word alignment: no	2	D3	D4

Conditions	Word offset	High Byte	Low Byte
Complete evaluation: any	0	-	CB/SB
Motorola format: no	1	D1	D0
Word alignment: yes	2	-	D2
	3	D4	D3

Conditions	Word offset	High Byte	Low Byte
Complete evaluation: any	0	-	CB/SB
Motorola format: yes	1	D0	D1
Word alignment: yes	2	-	D2
	3	D3	D4

Complete evaluation

Motorola format

Word alignment

CB

SB

D0/D1

(D2)

D3/D4

“-“

The terminal is mapped with control and status byte.

Motorola or Intel format can be set.

The terminal is positioned on a word limit in the Bus Coupler.

Control byte (appears in the process image of the outputs).

Status byte (appears in the process image of the inputs).

Counter word (read/set)

The period duration is output here, together with D3/D4.

Latch word (read)

This byte is not used or occupied by the terminal.

5.3 Register overview

Address	Designation	Default value	R/W	Storage medium
R0...R5	reserved	0x0000	R	
R6	Diagnostic register not used	0x0000	R	
R7	Command register not used	0x0000	R	
R8	Terminal type	5101	R	ROM
R9	Firmware version	0x????	R	ROM
R10	Multiplex shift register	0x0218/0130	R	ROM
R11	Signal channels	0x0130	R	ROM
R12	Minimum data length	0x03030	R	ROM
R13	Data structure	0x0000	R	ROM
R14	reserved	0x0000	R	
R15	Alignment register	variable	R/W	RAM
R16	Hardware version number	0x????	R/W	SEEROM
R17...R30	reserved	0x0000	R/W	SEEROM
R31	Code word register	variable	R/W	RAM
R32	Feature register	0x2200	R/W	SEEROM
R33...R61	reserved	0x0000	R/W	SEEROM

5.4 Register description

The registers can be read or written via the register communication. They are used for the parameterization of the terminal.

R0 to R7: Registers in the internal RAM of the terminal

The process variables can be used in addition to the actual process image. Their function is specific to the terminal.

- **R0 to R5: reserved**
- **R6: Diagnostic register**
The diagnostic register can contain additional diagnostic information. Parity errors, for instance, that occur in serial interface terminals during data transmission are indicated here.
- **R7: Command register**
High-Byte_Write = function parameter
Low-Byte_Write = function number
High-Byte_Read = function result
Low-Byte_Read = function number

R8 to R15: Registers in the internal ROM of the terminal

The type and system parameters are hard programmed by the manufacturer, and the user can read them but cannot change them.

- **R8: Terminal type**
The terminal type in register R8 is needed to identify the terminal.
- **R9: Software version (X.y)**
The software version can be read as a string of ASCII characters.
- **R10: Data length**
R10 contains the number of multiplexed shift registers and their length in bits.
The Bus Coupler sees this structure.
- **R11: Signal channels**
Related to R10, this contains the number of channels that are logically present. Thus for example a shift register that is physically present can perfectly well consist of several signal channels.

- **R12: Minimum data length**

The particular byte contains the minimum data length for a channel that is to be transferred. If the MSB is set, the control and status byte is not necessarily required for the terminal function and is not transferred to the control, if the Bus Coupler is configured accordingly.

- **R13: Data type register**

Data type register	Meaning
0x00	Terminal with no valid data type
0x01	Byte array
0x02	Structure 1 byte n bytes
0x03	Word array
0x04	Structure 1 byte n words
0x05	Double word array
0x06	Structure 1 byte n double words
0x07	Structure 1 byte 1 double word
0x08	Structure 1 byte 1 double word
0x11	Byte array with variable logical channel length
0x12	Structure 1 byte n bytes with variable logical channel length (e.g. 60xx)
0x13	Word array with variable logical channel length
0x14	Structure 1 byte n words with variable logical channel length
0x15	Double word array with variable logical channel length
0x16	Structure 1 byte n double words with variable logical channel length

- **R14: reserved**

- **R15: Alignment bits (RAM)**

The alignment bits are used to place the analog terminal in the Bus Coupler on a byte boundary.

R16 to R30: Manufacturer parameter area (SEEROM)

The manufacturer parameters are specific for each type of terminal. They are programmed by the manufacturer, but can also be modified by the controller. The manufacturer parameters are stored in a serial EEPROM in the terminal, and are retained in the event of voltage drop-out.

These registers can only be altered after a code word has been set in R31 [► 28].

R31 to R47: User parameter area (SEEROM)

The user parameters are specific for each type of terminal. They can be modified by the programmer. The user parameters are stored in a serial EEPROM in the terminal, and are retained in the event of voltage drop-out. The user area is write-protected by a code word.



Note

- **R31: Code word register in RAM**

The code word **0x1235** must be entered here so that parameters in the user area can be modified. If any other value is entered into this register, the write-protection is active. When write protection is not active, the code word is returned when the register is read. If the write protection is active, the register contains a zero value.

- **R32: Feature register**

[0x2200]

This register specifies the operation modes of the terminal.

Feature bit no.		Description of the operation mode
Bit 0	0	<ul style="list-style-type: none"> reserved, do not modify!
Bit 1	0/1	<ul style="list-style-type: none"> 0: Counter inhibit with high-level at the gate input [0] 1: Counter inhibit with low-level at gate input
Bit 2, Bit 3	00	<ul style="list-style-type: none"> Status input (active-low) is mapped into status byte 5 (ST.5) [00]
	01	<ul style="list-style-type: none"> reserved
	10	<ul style="list-style-type: none"> ST.5 = Status input, ST.6 = Status input
	11	<ul style="list-style-type: none"> ST.5 = Status input, ST.6 = !Status input
Bit 4 - Bit6	000	<ul style="list-style-type: none"> External Latch function active [000]
	001	<ul style="list-style-type: none"> Period measurement active
	010	<ul style="list-style-type: none"> reserved
	...	
	111	
Bit 7 - Bit 9	0	<ul style="list-style-type: none"> reserved, do not modify!
Bit 10, Bit 11	00	4-fold evaluation of the encoder signals A, B, C, i.e. both rising and falling edges of the encoder signals A, B are counted. [00]
	01	1-fold evaluation of the encoder signals A, B, C, i.e. each period of the encoder signal A is counted.
	10	2-fold evaluation of the encoder signals A, B, C, i.e. each edge of the encoder signal A is counted.
	11	4-fold evaluation of the encoder signals A, B, C
Bit 12 - Bit 14	0	<ul style="list-style-type: none"> reserved, do not modify!
Bit 15	0/1	0: Encoder Interface [0] 1: Counter mode is active. 16-bit up/down counter Input A: Counter Input B: Counting direction (5 V or open = up, 0 V = down) Input C: Latch

- **R33 - R47**
Registers that depend on the terminal type.
- **R47 - R63**
Extended registers with additional functions.

5.5 Control and status byte

5.5.1 Process data exchange

Control byte for process data exchange

The control byte is transferred from the controller to the terminal. It can be used

- in register mode (REG = 1) or
- in process data exchange (REG = 0).

Various actions are triggered in the KL5101 with the control byte:

Bit	7	6	5	4	3	2	1	0
Name	REG=0	-	-	-	EN_Latch_Ext_n	Cnt_Set	EN_LAT_EXT / RD_PERIOD	EN_LATC

Bit	Name	Function
3	En_Latch_Ext_n	The external latch input is activated for the negative edge. The counter value is stored in the latch register with the first external latch pulse after validity of the En_Latch_Ext_n bit. When this bit is set, the subsequent pulses do not have any effect on the latch register. Attention must be paid to ensuring that the corresponding latch valid bit (Latch_Ext_Val) has been removed from the terminal before alerting of the zero pulse. This functionality can be set in the feature register [► 28] (default setting).
2	Cnt_Set	A rising edge at Cnt_Set will set the counter to the value specified in the process data.
1	En_Latch_Ext	The external latch input is activated for the positive edge. The counter value is stored in the latch register with the first external latch pulse after validity of the En_Latch_Ext bit. When this bit is set, the subsequent pulses do not have any effect on the latch register. Attention must be paid to ensuring that the corresponding latch valid bit (Latch_Ext_Val) has been removed from the terminal before alerting of the zero pulse. This functionality can be set in the feature register [► 28] (default setting).
	RD_Period	The periods between two positive edges at input A are measured with a resolution of 200 ns. When the bit is set, this period is output in data bytes D2, D3 and D4. This functionality can be set in the feature register [► 28] .
0	En_Latch	The zero point latch (C input) is activated. The counter value is stored in the latch register with the first external latch pulse after validity of the En_Latch bit (this has priority over En_Latch_Ext). When this bit is set, the subsequent pulses do not have any effect on the latch register. Attention must be paid to ensuring that the corresponding latch valid bit (Latch_Val) has been removed from the terminal before alerting of the zero pulse. (the Latch_Val bit cannot be removed from the terminal until the C pulse has a low level).



Note

For the external latch input:

Activation of the positive edge (En_Latch_Ext = 1) has priority over activation of the negative edge (En_Latch_Ext_N = 1).

Status byte for process data exchange

The status byte is transmitted from the terminal to the controller. The status byte contains various status bits of the KL5101.

Bit	7	6	5	4	3	2	1	0
Name	REG=0	-	State_Input	Overflow	Underflow	CntSet_Acc	Latch_Ext_Val/ RD_Period_Q	Latch_Val

Bit	Name	
5	State_Input	The state of the Status input is mapped in this Bit (adjustable via feature register [▶ 28]).
4	Overflow	This bit is set if an overflow (65535 to 0) of the 16-bit counter occurs. It is reset when the counter exceeds a third of the measuring range (21845 to 21846) or as soon as an underflow occurs.
3	Underflow	This bit is set if an underflow (0 to 65535) of the 16-bit counter occurs. It is reset when the counter drops below two thirds of the measuring range (from 43690 to 43689), or immediately an overflow occurs.
2	CntSet_Acc	The data for setting the counter has been accepted by the terminal.
1	Latch_Ext_Val	An external latch pulse has occurred. The data D2, D3 in the process image correspond to the latched value when the bit is set. To reactivate the latch input, En_Latch_Ext must first be removed and then set again.
	RD_Period_Q	Data bytes 2, 3 and 4 contain the period duration.
0	Latch_Val	A zero point latch has occurred. The data D2, D3 in the process image correspond to the latched value when the bit is set. To reactivate the latch input, En_Latch must first be removed and then set again.

5.5.2 Register communication

Register access via process data exchange

- **Bit 7=1: Register mode**
If bit 7 of the control byte is set, the first two bytes of the user data are not used for process data exchange but written into the register set of the terminal or read from it.
- **Bit 6=0: read, bit 6=1: write**
Bit 6 of the control bytes is used to specify whether a register should be read or written.
 - **Bit 6=0:** A register is read without changing it. The value can be found in the input process image.
 - **Bit 6=1:** The user data are written into a register. The process is complete once the status byte in the input process image has returned an acknowledgment (see example).
- **Bit 0 to 5: Address**
The address of the register to be addressed is entered in bits 0 to 5 of the control byte

Control byte in register mode (REG=1)

Bit	7	6	5	4	3	2	1	0
Name	REG=1	W/R	A5	A4	A3	A2	A1	A0

REG = 0_{bin}: Process data exchange
 REG = 1_{bin}: Access to register structure

W/R = 0_{bin}: Read register
 W/R = 1_{bin}: Write register

A5..A0 = register address
 Addresses A5...A0 can be used to address a total of 64 registers.

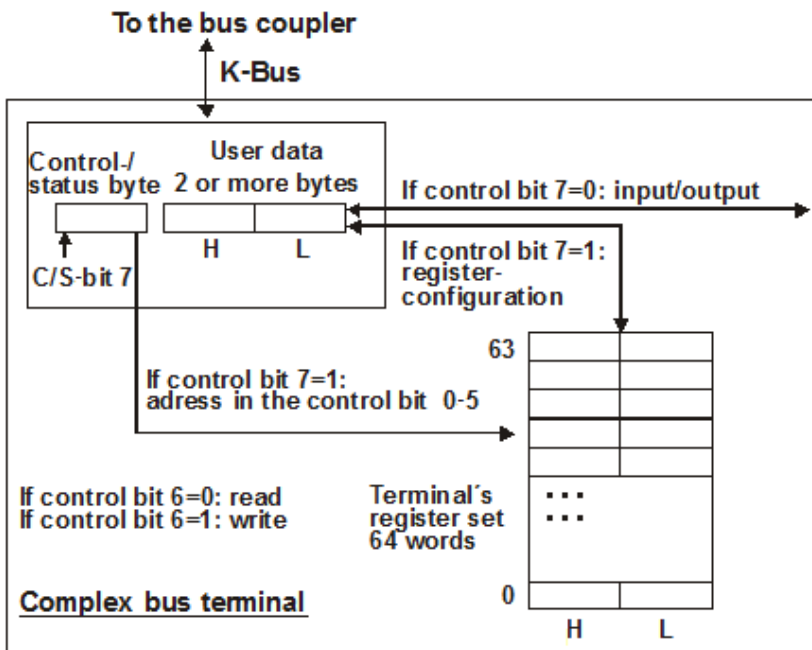

Fig. 15: Register mode control byte

The control or status byte occupies the lowest address of a logical channel. The corresponding register values are located in the following 2 data bytes. (The BK2000 is an exception: here, an unused data byte is inserted after the control or status byte, and the register value is therefore placed on a word boundary).

Example 1:

Reading register 8 in the BK2000 with a KL5101 and the end terminal:

If the following bytes are transferred from the controller to the terminal,

Byte	Byte 3	Byte 2	Byte 1	Byte 0
Name	DataOUT, low byte	DataOUT, high byte	Not used	Control byte
Value	0xXX	0xXX	0xXX	0x88

the terminal then returns the following type designation (0x0BCE 0x13ED corresponds to the unsigned integer 5101).

Byte	Byte 3	Byte 2	Byte 1	Byte 0
Name	DataIN, low byte	Data IN, high byte	Not used	Status byte
Value	0xED	0x13	0x00	0x88

Example 2

Writing of register 31 in the BK2000 with an intelligent terminal and the end terminal:

If the following bytes (user code word) are transferred from the controller to the terminal,

Byte	Byte 3	Byte 2	Byte 1	Byte 0
Name	DataOUT, low byte	DataOUT, high byte	Not used	Control byte
Value	0x35	0x12	0xXX	0xDF

the user code word is set and the terminal returns the register address with the bit 7 for register access as acknowledgement.

Byte	Byte 3	Byte 2	Byte 1	Byte 0
Name	DataIN, low byte	DataIN, high byte	Not used	Status byte
Value	0x00	0x00	0x00	0x9F

5.6 Examples of Register Communication

The numbering of the bytes in the examples corresponds to the display without word alignment.

5.6.1 Example 1: reading the firmware version from Register 9

Output Data

Byte 0: Control byte	Byte 1: DataOUT1, high byte	Byte 2: DataOUT1, low byte
0x89 (1000 1001 _{bin})	0xXX	0xXX

Explanation:

- Bit 0.7 set means: Register communication switched on.
- Bit 0.6 not set means: reading the register.
- Bits 0.5 to 0.0 specify the register number 9 with 00 1001_{bin}.
- The output data word (byte 1 and byte 2) has no meaning during read access. To change a register, write the required value into the output word.

Input Data (answer of the bus terminal)

Byte 0: Status byte	Byte 1: DataIN1, high byte	Byte 2: DataIN1, low byte
0x89	0x33	0x41

Explanation:

- The terminal returns the value of the control byte as a receipt in the status byte.
- The terminal returns the firmware version 0x3341 in the input data word (byte 1 and byte 2). This is to be interpreted as an ASCII code:
 - ASCII code 0x33 represents the digit 3
 - ASCII code 0x41 represents the letter A
 The firmware version is thus 3A.

5.6.2 Example 2: Writing to an user register



Note

Code word

In normal mode all user registers are read-only with the exception of Register 31. In order to deactivate this write protection you must write the code word (0x1235) into Register 31. If a value other than 0x1235 is written into Register 31, write protection is reactivated. Please note that changes to a register only become effective after restarting the terminal (power-off/power-on).

I. Write the code word (0x1235) into Register 31.

Output Data

Byte 0: Control byte	Byte 1: DataOUT1, high byte	Byte 2: DataOUT1, low byte
0xDF (1101 1111 _{bin})	0x12	0x35

Explanation:

- Bit 0.7 set means: Register communication switched on.
- Bit 0.6 set means: writing to the register.
- Bits 0.5 to 0.0 specify the register number 31 with 01 1111_{bin}.
- The output data word (byte 1 and byte 2) contains the code word (0x1235) for deactivating write protection.

Input Data (answer of the bus terminal)

Byte 0: Status byte	Byte 1: DataIN1, high byte	Byte 2: DataIN1, low byte
0x9F (1001 1111 _{bin})	0xXX	0xXX

Explanation:

- The terminal returns a value as a receipt in the status byte that differs only in bit 0.6 from the value of the control byte.
- The input data word (byte 1 and byte 2) is of no importance after the write access. Any values still displayed are invalid!

II. Read Register 31 (check the set code word)**Output Data**

Byte 0: Control byte	Byte 1: DataOUT1, high byte	Byte 2: DataOUT1, low byte
0x9F (1001 1111 _{bin})	0xXX	0xXX

Explanation:

- Bit 0.7 set means: Register communication switched on.
- Bit 0.6 not set means: reading the register.
- Bits 0.5 to 0.0 specify the register number 31 with 01 1111_{bin}.
- The output data word (byte 1 and byte 2) has no meaning during read access.

Input Data (answer of the bus terminal)

Byte 0: Status byte	Byte 1: DataIN1, high byte	Byte 2: DataIN1, low byte
0x9F (1001 1111 _{bin})	0x12	0x35

Explanation:

- The terminal returns the value of the control byte as a receipt in the status byte.
- The terminal returns the current value of the code word register in the input data word (byte 1 and byte 2).

III. Write to Register 32 (change contents of the feature register)**Output data**

Byte 0: Control byte	Byte 1: DataIN1, high byte	Byte 2: DataIN1, low byte
0xE0 (1110 0000 _{bin})	0x00	0x02

Explanation:

- Bit 0.7 set means: Register communication switched on.
- Bit 0.6 set means: writing to the register.
- Bits 0.5 to 0.0 indicate register number 32 with 10 0000_{bin}.
- The output data word (byte 1 and byte 2) contains the new value for the feature register.

**Observe the register description!**

The value of 0x0002 given here is just an example!
The bits of the feature register change the properties of the terminal and have a different meaning, depending on the type of terminal. Refer to the description of the feature register of your terminal (chapter *Register description*) regarding the meaning of the individual bits before changing the values.

Input data (response from the Bus Terminal)

Byte 0: Status byte	Byte 1: DataIN1, high byte	Byte 2: DataIN1, low byte
0xA0 (1010 0000 _{bin})	0xXX	0xXX

Explanation:

- The terminal returns a value as a receipt in the status byte that differs only in bit 0.6 from the value of the control byte.
- The input data word (byte 1 and byte 2) is of no importance after the write access. Any values still displayed are invalid!

IV. Read Register 32 (check changed feature register)

Output Data

Byte 0: Control byte	Byte 1: DataOUT1, high byte	Byte 2: DataOUT1, low byte
0xA0 (1010 0000 _{bin})	0xXX	0xXX

Explanation:

- Bit 0.7 set means: Register communication switched on.
- Bit 0.6 not set means: reading the register.
- Bits 0.5 to 0.0 indicate register number 32 with 10 0000_{bin}.
- The output data word (byte 1 and byte 2) has no meaning during read access.

Input Data (answer of the bus terminal)

Byte 0: Status byte	Byte 1: DataIN1, high byte	Byte 2: DataIN1, low byte
0xA0 (1010 0000 _{bin})	0x00	0x02

Explanation:

- The terminal returns the value of the control byte as a receipt in the status byte.
- The terminal returns the current value of the feature register in the input data word (byte 1 and byte 2).

V. Write Register 31 (reset code word)

Output Data

Byte 0: Control byte	Byte 1: DataOUT1, high byte	Byte 2: DataOUT1, low byte
0xDF (1101 1111 _{bin})	0x00	0x00

Explanation:

- Bit 0.7 set means: Register communication switched on.
- Bit 0.6 set means: writing to the register.
- Bits 0.5 to 0.0 specify the register number 31 with 01 1111_{bin}.
- The output data word (byte 1 and byte 2) contains 0x0000 for reactivating write protection.

Input Data (answer of the bus terminal)

Byte 0: Status byte	Byte 1: DataIN1, high byte	Byte 2: DataIN1, low byte
0x9F (1001 1111 _{bin})	0xXX	0xXX

Explanation:

- The terminal returns a value as a receipt in the status byte that differs only in bit 0.6 from the value of the control byte.
- The input data word (byte 1 and byte 2) is of no importance after the write access. Any values still displayed are invalid!

6 Appendix

6.1 Support and Service

Beckhoff and their partners around the world offer comprehensive support and service, making available fast and competent assistance with all questions related to Beckhoff products and system solutions.

Beckhoff's branch offices and representatives

Please contact your Beckhoff branch office or representative for [local support and service](#) on Beckhoff products!

The addresses of Beckhoff's branch offices and representatives round the world can be found on her internet pages:

<http://www.beckhoff.com>

You will also find further [documentation](#) for Beckhoff components there.

Beckhoff Headquarters

Beckhoff Automation GmbH & Co. KG

Huelshorstweg 20
33415 Verl
Germany

Phone:	+49(0)5246/963-0
Fax:	+49(0)5246/963-198
e-mail:	info@beckhoff.com

Beckhoff Support

Support offers you comprehensive technical assistance, helping you not only with the application of individual Beckhoff products, but also with other, wide-ranging services:

- support
- design, programming and commissioning of complex automation systems
- and extensive training program for Beckhoff system components

Hotline:	+49(0)5246/963-157
Fax:	+49(0)5246/963-9157
e-mail:	support@beckhoff.com

Beckhoff Service

The Beckhoff Service Center supports you in all matters of after-sales service:

- on-site service
- repair service
- spare parts service
- hotline service

Hotline:	+49(0)5246/963-460
Fax:	+49(0)5246/963-479
e-mail:	service@beckhoff.com

List of illustrations

Fig. 1	KL5101	8
Fig. 2	Assignment of the terminal contacts	11
Fig. 3	Spring contacts of the Beckhoff I/O components	12
Fig. 4	Attaching on mounting rail	13
Fig. 5	Disassembling of terminal	14
Fig. 6	Power contact on left side	15
Fig. 7	Standard wiring	17
Fig. 8	Pluggable wiring	17
Fig. 9	High Density Terminals	17
Fig. 10	Connecting a cable on a terminal point	18
Fig. 11	KS2000 configuration software	22
Fig. 12	Mapping for Lightbus Coupler - example for KL5101	24
Fig. 13	Mapping for Profibus Coupler - example for KL5101	25
Fig. 14	Mapping for Interbus Coupler - example for KL5101	25
Fig. 15	Register mode control byte	32