



Documentation

KL2532/KS2532, KL2552/KS2552

Two channel power stage terminals for DC motors

Version: 3.2.1
Date: 2019-12-11

BECKHOFF

Table of contents

1 Foreword	5
1.1 Notes on the documentation.....	5
1.2 Safety instructions	6
1.3 Documentation issue status	7
1.4 Beckhoff Identification Code (BIC)	9
2 Product overview	11
2.1 KL2532 - Introduction	11
2.2 KL2552 - Introduction	12
2.3 Technical data	13
2.4 KL2532 - LED displays	14
2.5 KL2552 - LED displays	15
3 Basic function principles	16
3.1 Basic principles.....	16
3.2 Chopper operation.....	18
4 Mounting and wiring	20
4.1 Instructions for ESD protection.....	20
4.2 Installation on mounting rails	20
4.3 Installation instructions for enhanced mechanical load capacity	23
4.4 Installation position for operation with or without fan	24
4.5 Connection	27
4.5.1 Connection system	27
4.5.2 Wiring.....	29
4.5.3 Shielding	30
4.6 UL notice - Compact Motion	30
4.7 KL2532/KS2532 - connection.....	32
4.8 KL2552-0000/KS2552-0000 - connection	33
4.9 KL2552-0005/KS2552-0005 - connection	35
4.10 KL2552 - application example	37
5 Configuration software KS2000	38
5.1 KS2000 - Introduction.....	38
5.2 Parameterization with KS2000	39
5.3 Register	41
5.4 Settings.....	42
5.5 Process data.....	45
6 Access from the user program	47
6.1 Process image	47
6.2 Control and status bytes.....	47
6.3 Register overview	50
6.4 Register description.....	53
6.5 Examples of Register Communication	60
6.5.1 Example 1: reading the firmware version from Register 9.....	60
6.5.2 Example 2: Writing to an user register.....	61
7 Appendix	64

7.1 Support and Service 64

1 Foreword

1.1 Notes on the documentation

Intended audience

This description is only intended for the use of trained specialists in control and automation engineering who are familiar with the applicable national standards.

It is essential that the documentation and the following notes and explanations are followed when installing and commissioning these components.

It is the duty of the technical personnel to use the documentation published at the respective time of each installation and commissioning.

The responsible staff must ensure that the application or use of the products described satisfy all the requirements for safety, including all the relevant laws, regulations, guidelines and standards.

Disclaimer

The documentation has been prepared with care. The products described are, however, constantly under development.

We reserve the right to revise and change the documentation at any time and without prior announcement.

No claims for the modification of products that have already been supplied may be made on the basis of the data, diagrams and descriptions in this documentation.

Trademarks

Beckhoff®, TwinCAT®, TwinCAT/BSD®, TC/BSD®, EtherCAT®, EtherCAT G®, EtherCAT G10®, EtherCAT P®, Safety over EtherCAT®, TwinSAFE®, XFC®, XTS® and XPlanar® are registered trademarks of and licensed by Beckhoff Automation GmbH. Other designations used in this publication may be trademarks whose use by third parties for their own purposes could violate the rights of the owners.

Patent Pending

The EtherCAT Technology is covered, including but not limited to the following patent applications and patents: EP1590927, EP1789857, EP1456722, EP2137893, DE102015105702 with corresponding applications or registrations in various other countries.



EtherCAT® is registered trademark and patented technology, licensed by Beckhoff Automation GmbH, Germany.

Copyright

© Beckhoff Automation GmbH & Co. KG, Germany.

The reproduction, distribution and utilization of this document as well as the communication of its contents to others without express authorization are prohibited.

Offenders will be held liable for the payment of damages. All rights reserved in the event of the grant of a patent, utility model or design.

1.2 Safety instructions

Safety regulations

Please note the following safety instructions and explanations!
Product-specific safety instructions can be found on following pages or in the areas mounting, wiring, commissioning etc.

Exclusion of liability

All the components are supplied in particular hardware and software configurations appropriate for the application. Modifications to hardware or software configurations other than those described in the documentation are not permitted, and nullify the liability of Beckhoff Automation GmbH & Co. KG.

Personnel qualification

This description is only intended for trained specialists in control, automation and drive engineering who are familiar with the applicable national standards.

Description of instructions

In this documentation the following instructions are used.
These instructions must be read carefully and followed without fail!

DANGER

Serious risk of injury!

Failure to follow this safety instruction directly endangers the life and health of persons.

WARNING

Risk of injury!

Failure to follow this safety instruction endangers the life and health of persons.

CAUTION

Personal injuries!

Failure to follow this safety instruction can lead to injuries to persons.

NOTE

Damage to environment/equipment or data loss

Failure to follow this instruction can lead to environmental damage, equipment damage or data loss.



Tip or pointer

This symbol indicates information that contributes to better understanding.

1.3 Documentation issue status

Version	Comment
3.2.1	<ul style="list-style-type: none"> • Update revision status • Update structure
3.2.0	<ul style="list-style-type: none"> • Update chapter Instructions for ESD protection • Chapter "Beckhoff Identification Code (BIC)" added
3.1.0	<ul style="list-style-type: none"> • Update chapter "Notes on the documentation" • Update chapter "Technical data" • Chapter "Instructions for ESD protection" added • Update chapter "Connection system" -> "Connection" • Chapter "Installation instructions for enhanced mechanical load capacity" added • Chapter "Prescribed installation position" replaced with chapter "Installation position with or without fan)" • Update revision status • Chapter "UL notice - Compact Motion" added
3.0.0	<ul style="list-style-type: none"> • Migration • Update revision status • Update structure
2.6.0	<ul style="list-style-type: none"> • LED displays of the KL2532/KS2532 updated • Technical data updated
2.5.0	<ul style="list-style-type: none"> • Technical data updated • Register overview corrected • Register description expanded
2.4.0	<ul style="list-style-type: none"> • Basic function principles updated • Register description expanded • Technical data updated • Mounting instructions updated
2.3.0	<ul style="list-style-type: none"> • Technical data updated
2.2.0	<ul style="list-style-type: none"> • Mounting instructions updated
2.1.0	<ul style="list-style-type: none"> • Introduction for KL2552 updated • Register description updated • Notes on connection methods extended
2.0.0	<ul style="list-style-type: none"> • KL2532 added • Notes on connection methods added
1.1.0	<ul style="list-style-type: none"> • Register description expanded • Description of the KS2000 configuration software expanded • Description of KL2552-0005 added • Technical data updated • Description of chopper mode added • Application example added
1.0.0	<ul style="list-style-type: none"> • English translation published • Minor layout corrections
0.2	<ul style="list-style-type: none"> • Basic function principles added • Description of control and status byte extended • Register description corrected
0.1	First provisional documentation for KL2552-0000

Firmware and hardware versions

Documentation version	KL2532/KS2532			KL2552-0000/KS2552-0000			KL2552-0005/KS2552-0005		
	Firmware		Hardware	Firmware		Hard-ware	Firmware		Hardware
	K-bus	Power Stage		K-Bus	Power Stage		K-Bus	Power Stage	
3.2.1	3B	3B	07	2C	2C	09	2C	2C	09
3.2.0	3B	3B	07	2C	2C	09	2C	2C	09
3.1.0	3B	3B	07	2C	2C	09	2C	2C	09
3.0.0	3B	3B	07	1M	1M	07	1M	1M	07
2.6.0									
2.5.0	3B	3B	05	1M	1M	03	1M	1M	04
2.4.0	3B	3B	05	1M	1M	03	1M	1M	04
2.3.0	3B		05	1M		03	1M		04
2.2.0	1A	1A	02	1C	1E	00	1C	1E	00
2.1.0	1A	1A	02	1C	1E	00	1C	1E	00
2.0.0	1A	1A	00	1C	1E	00	1C	1E	00
1.1.0	-	-	-	1B	1D	00	1B	1D	00
1.0.0				1A	1A	00	1A	1A	00
0.2				1A	1A	00	1A	1A	00
0.1				1A	1A	00	1A	1A	00

The K-bus firmware and hardware version (delivery state) can be found on the terminal side on which the serial number is printed.

Syntax of the serial number

Structure of the serial number: WW YY FF HH

WW - week of production (calendar week)
 YY - year of production
 FF - K-bus firmware version
 HH - hardware version

Example with ser. no.: 49 05 1B 03:

49 - week of production 49
 05 - year of production 2005
 1B - firmware version 1B
 03 - hardware version 03

1.4 Beckhoff Identification Code (BIC)

The Beckhoff Identification Code (BIC) is increasingly being applied to Beckhoff products to uniquely identify the product. The BIC is represented as a Data Matrix Code (DMC, code scheme ECC200), the content is based on the ANSI standard MH10.8.2-2016.

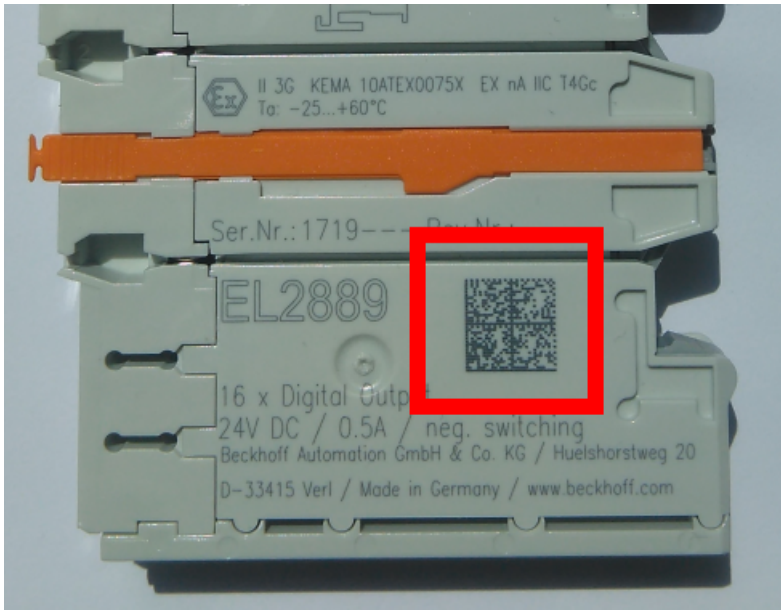

Fig. 1: BIC as data matrix code (DMC, code scheme ECC200)

The BIC will be introduced step by step across all product groups.

Depending on the product, it can be found in the following places:

- on the packaging unit
- directly on the product (if space suffices)
- on the packaging unit and the product

The BIC is machine-readable and contains information that can also be used by the customer for handling and product management.

Each piece of information can be uniquely identified using the so-called data identifier (ANSI MH10.8.2-2016). The data identifier is followed by a character string. Both together have a maximum length according to the table below. If the information is shorter, spaces are added to it. The data under positions 1 to 4 are always available.

The following information is contained:

Item no.	Type of information	Explanation	Data identifier	Number of digits incl. data identifier	Example
1	Beckhoff order number	Beckhoff order number	1P	8	1P 072222
2	Beckhoff Traceability Number (BTN)	Unique serial number, see note below	S	12	S BTNk4p562d7
3	Article description	Beckhoff article description, e.g. EL1008	1K	32	1K EL1809
4	Quantity	Quantity in packaging unit, e.g. 1, 10, etc.	Q	6	Q 1
5	Batch number	Optional: Year and week of production	2P	14	2P 401503180016
6	ID/serial number	Optional: Present-day serial number system, e.g. with safety products or calibrated terminals	51S	12	51S 678294104
7	Variant number	Optional: Product variant number on the basis of standard products	30P	32	30P F971, 2*K183
...					

Further types of information and data identifiers are used by Beckhoff and serve internal processes.

Structure of the BIC

Example of composite information from item 1 to 4 and 6. The data identifiers are marked in red for better display:

BTN

An important component of the BIC is the Beckhoff Traceability Number (BTN, item no. 2). The BTN is a unique serial number consisting of eight characters that will replace all other serial number systems at Beckhoff in the long term (e.g. batch designations on IO components, previous serial number range for safety products, etc.). The BTN will also be introduced step by step, so it may happen that the BTN is not yet coded in the BIC.

NOTE

This information has been carefully prepared. However, the procedure described is constantly being further developed. We reserve the right to revise and change procedures and documentation at any time and without prior notice. No claims for changes can be made from the information, illustrations and descriptions in this information.

2 Product overview

2.1 KL2532 - Introduction

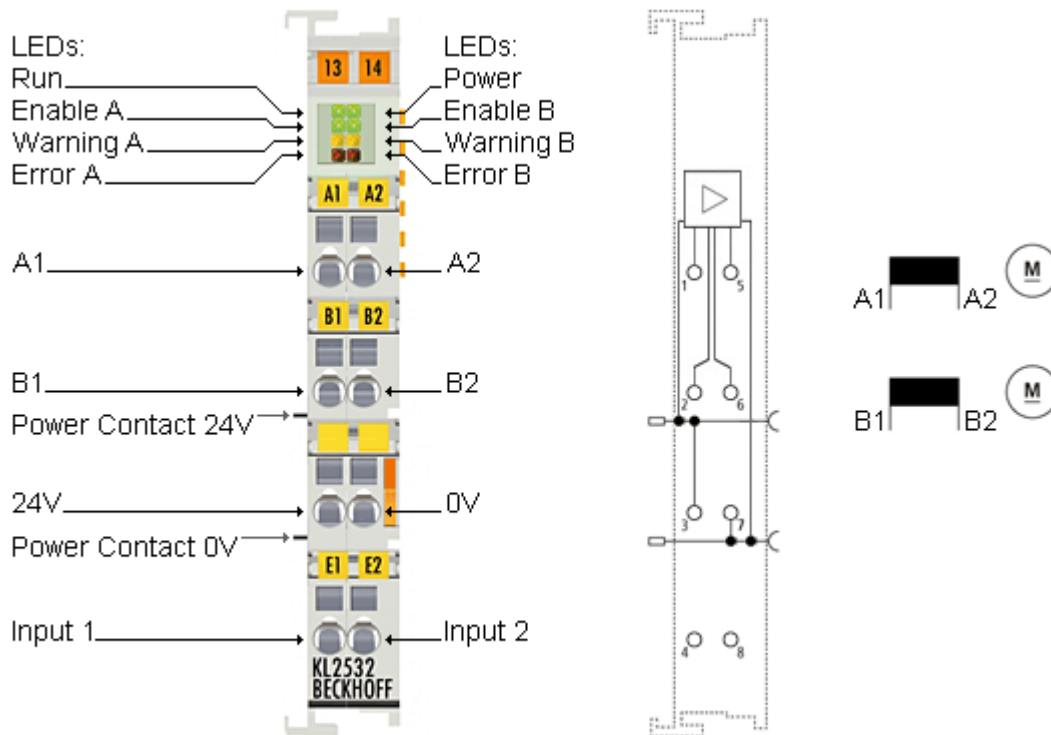

Fig. 2: KL2532

The two-channel KL2532/KS2532 Bus Terminal enables direct operation of two DC motors. The set speed is specified by the automation device with a resolution of 16 bit.

The output stage is protected against overload and short-circuit and is electrically isolated from the K-bus. Both channels indicate their signal state through LEDs, which enable quick on-site diagnosis.

The Bus Terminal is available in the KL2532 version for standard wiring and the KS2532 for permanent wiring.

2.2 KL2552 - Introduction

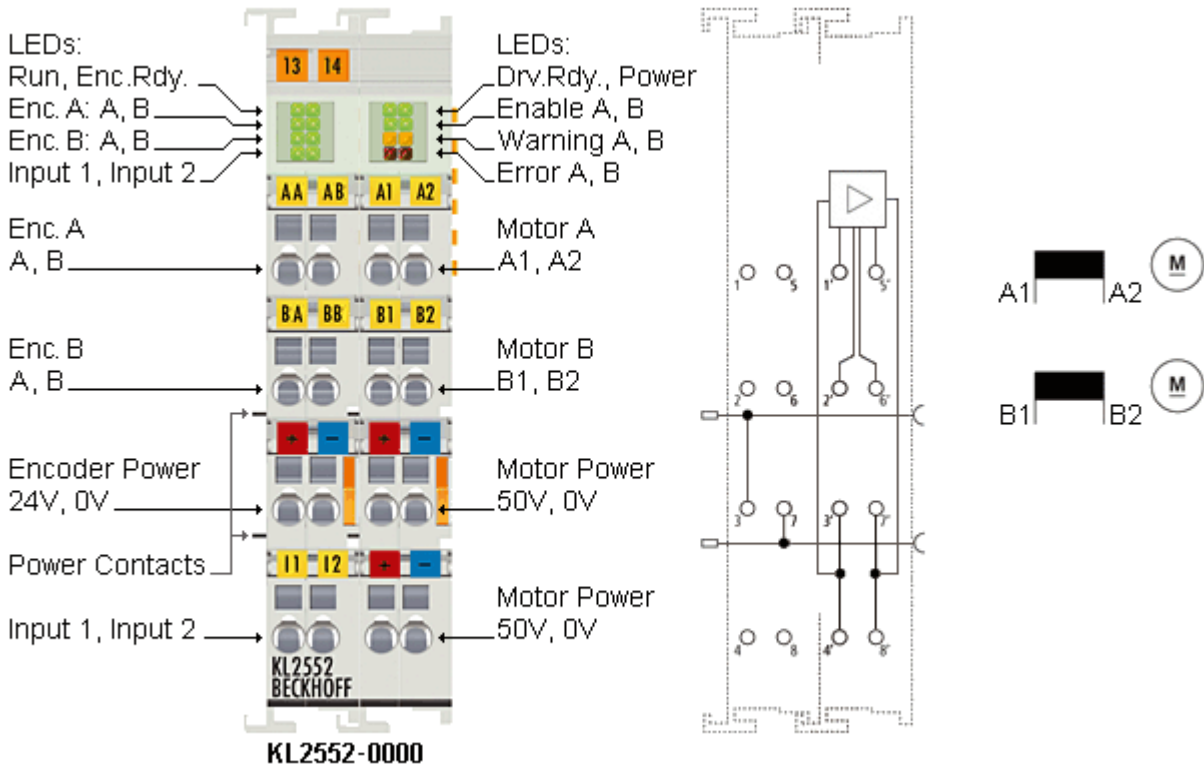

Fig. 3: KL2552

The two-channel KL2552/KS2552 Bus Terminal enables direct operation of two DC motors. The set speed is specified by the automation device with a resolution of 16 bit.

The output stage is protected against overload and short-circuit and is electrically isolated from the K-bus. A servo axis can easily be realized by connecting an incremental encoder.

Typical motor parameters can be set in order to avoid critical conditions of the DC motor. The load can be protected by limiting the maximum speed and torque values.

Both channels indicate their signal state through LEDs, which enable quick on-site diagnosis.

The Bus Terminal is available in the KL2552 version for standard wiring and the KS2552 for permanent wiring.

2.3 Technical data

Technical data		KL2532-0000 KS2532-0000	KL2552-0000 KS2552-0000	KL2552-0005 KS2552-0005
Number of DC motor output stages		2		
Load type		DC brush motors, inductive		
Supply for the output stage		via power contacts	via terminal points	
Rated load voltage (motor power)		24 V _{DC}	8 V _{DC} to 50 V _{DC}	
Output current per channel		Rated current 1 A, Peak current 2.5 A	Rated current 5 A, peak current 8 A (short-circuit-proof, common thermal overload warning for both output stages)	
PWM clock frequency		30 kHz, channels out of phase by 180° relative to each other		
Duty factor		0 ... 100% (voltage-controlled)		
Resolution	Current	10 bit		
	Voltage (velocity)	16 bit		
Number of digital inputs		2 (for end positions)		
Input filter		0.2 ms		
Signal voltage at digital input "0"		-3 V ... 1.5 V		
Signal voltage at digital input "1"		30 V		
Input current		typically: 5.5 mA		
Number of encoder inputs		-	4 (for an encoder system)	
Encoder signal		-	5...24 V, 5 mA single-ended	5 V, 5 mA single-ended
Encoder supply		-	24 V, max. 100 mA	5 V, max. 80 mA
Pulse frequency		-	max. 400000 increments/s (with four-fold evaluation)	
Encoder voltage "0"		-	-3 V ... 1.5 V	
Encoder voltage "1"		-	30 V	
Electrical isolation		500 V (K-bus/mains voltage)		
Supply voltage for internal electronic		via the K-bus and through the power contacts		
Current consumption from K-bus (5 V)		typ. 50 mA	typ. 70 mA	typ. 120 mA
Current consumption from the power contacts		typ. 30 mA + motor current	typ. 40 mA + sensor supply	typ. 120 mA
Bit width in the input process image		2 x 16 bit data, 2 x 8 bit status		
Bit width in the output process image		2 x 16 bit data, 2 x 8 bit control		
Configuration		via the Bus Coupler or the controller		
Weight		approx. 55 g	approx. 100 g	
Permissible ambient temperature range during operation		0°C ... + 55°C		
Permissible ambient temperature range during storage		-25°C ... + 85°C		
Permissible relative humidity		95 %, no condensation		
Dimensions (W x H x D)		approx. 14 mm x 100 mm x 70 mm (width aligned: 12 mm)	approx. 27 mm x 100 mm x 70 mm (width aligned: 24 mm)	
Mounting [▶ 20]		on 35 mm mounting rail conforms to EN 60715		
Vibration/shock resistance		conforms to EN 60068-2-6 / EN 60068-2-27, see also installation instructions for terminals with increased mechanical load capacity [▶ 23]		
EMC immunity/emission		conforms to EN 61000-6-2 / EN 61000-6-4, EN 61800-6-33 * *) standard: category C3. Additional filters are required for categories C1 and C2!		
Protection class		IP20		
Installation position		without fan cartridge ZB8610 : standard installing position with fan cartridge ZB8610 : standard installing position, other installing positions (example 1 & 2) see notice [▶ 24]		
Approval		CE, cULus [▶ 30]		

2.4 KL2532 - LED displays

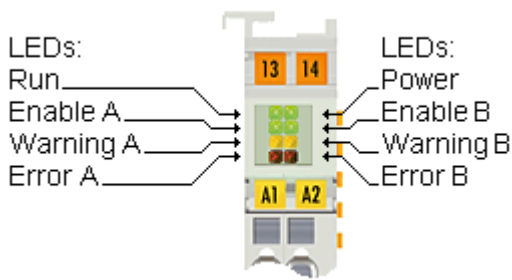

Fig. 4: KL2532 - LEDs

LED	Display	
Run (green)	reserved	Data transmission on the K-bus is active
Enable A (green)	off	Channel 1 is either not enabled or not ready to operate.
	on	Channel 1 is enabled and is ready to operate.
Warning A (yellow)	on	The internal temperature has risen to more than 80 °C, or the power supply voltage has dropped.
Error A (red)	on	There is an error at channel 1
Power (green)	off	The power supply voltage is absent (less than 7 V).
	on	The power supply voltage is present (more than 8 V).
Enable B (green)	off	Channel 2 is either not enabled or not ready to operate.
	on	Channel 2 is enabled and is ready to operate.
Warning B (yellow)	on	The internal temperature has risen to more than 80 °C, or the power supply voltage has dropped.
Error B (red)	on	There is an error at channel 2

2.5 KL2552 - LED displays

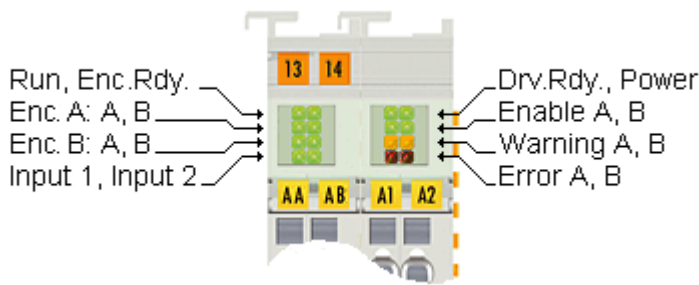

Fig. 5: KL2552 - LEDs

Left LED prism

LED	Display	
Run (green)	on	Data transmission on the K-bus is active
Enc. A: A (green)	on	There is a signal at input A for encoder A.
Enc. B: A (green)	on	There is a signal at input A for encoder B.
Input 1 (green)	on	There is a signal at input 1.
Enc. Rdy. (green)	on	Encoder evaluation ready to operate.
Enc. A: B (green)	on	There is a signal at input B for encoder A.
Enc. B: B (green)	on	There is a signal at input B for encoder B.
Input 2 (green)	on	There is a signal at input 2.

Right LED prism

LED	Display	
Drv. Rdy. (green)	on	Motor driver ready to operate.
Enable A (green)	off	Channel 1 is either not enabled or not ready to operate.
	on	Channel 1 is enabled and is ready to operate.
Warning A (yellow)	on	Warning of channel 1
Error A (red)	on	There is an error at channel 1
Power (green)	off	The motor supply voltage is not available.
	on	The motor supply voltage is available.
Enable B (green)	off	Channel 2 is either not enabled or not ready to operate.
	on	Channel 2 is enabled and is ready to operate.
Warning B (yellow)	on	Warning of channel 2
Error B (red)	on	There is an error at channel 2

3 Basic function principles

3.1 Basic principles

The KL2532/KS2532 DC motor terminal integrates two compact DC motor output stages up to 24 W in a very compact design.

The KL2552/KS2552 DC motor terminal integrates two compact DC motor output stages up to 250 W in a very compact design.

General functions

Enable/Readiness for operation

For activating the output stage enable bit [CB1.5](#) [[▶ 47](#)] has to be set. If the terminal is in an error-free state at the time, it sets ready bit [SB1.4](#) [[▶ 48](#)] as acknowledgement. If the terminal is ready to operate, it indicates this by setting "Ready to Enable" ([R0.2](#) [[▶ 53](#)]). Directions of rotation are indicated by bit [R0.4](#) [[▶ 53](#)] (Moving Positive) and [R0.5](#) [[▶ 53](#)] (Moving Negative).

Set / delete position

The user can set or delete the current position value. Register [R5](#) [[▶ 54](#)] is used as reference. A rising edge at bit [CB1.1](#) [[▶ 47](#)] sets the current position, and the acknowledgement is provided through status bit [SB1.1](#) [[▶ 48](#)].

Counter function

The digital inputs of the terminal act on internal counters of the terminal.

Input 1 for channel 1 and input 2 for channel 2.

In connection with a setpoint specification, the positive edges of the input lead to an incrementing of the counter in the case of a positive specification and to a decrementing of the internal counter in the case of a negative specification. If no setpoint is specified, state changes at the input have no effect on the internal counter.

Latch functions (only KL2552/KS2552)

The internal encoder offers the option of registering a latch event. A latch event can be generated via the digital input signals.

The terminal response to the latch events is activated as follows:

- Setting the control bit [CB1.2](#) [[▶ 47](#)] activates the rising edge at the digital input (highest priority)
- Setting the control bit [CB1.3](#) [[▶ 47](#)] activates the falling edge at the digital input (second-highest priority)

Once the user has enabled the function, during the next latch event, the terminal saves the current position value and indicates this by setting status bit [SB1.2](#) [[▶ 48](#)]. Reading of latch values must be initiated by setting [CB1.4](#) [[▶ 47](#)], which causes the latch value to be mapped in the DataIN process data (the terminal indicates this via status bit [SB1.3](#) [[▶ 48](#)]).

Reading the latch value

i The enable that was set previously must be retained while reading out the latch value. The latch value is lost if enable is cancelled!

Manual and automatic torque reduction

A torque reduction can be achieved in two ways:

- [R32.10 \[► 56\]](#) = 0: The torque is reduced (to the value in [R41 \[► 58\]](#) or [R49 \[► 59\]](#)), if [CB1.0 \[► 47\]](#) = 1. The terminal acknowledges this by setting [SB1.1 \[► 48\]](#).
- [R32.10 \[► 56\]](#) = 1: The torque is automatically reduced, if the process input data exceed the values configured in R45 or R48. The torque is reduced automatically if the process input data exceed the settings configured in [R45 \[► 59\]](#) or [R48 \[► 59\]](#). The reduction is deactivated, if the process input data fall below a value of R45 or R48 - 2%.

R41 (reduced torque) and R45 (torque threshold) are used for the positive direction of rotation.

R49 (reduced torque) and R48 (torque threshold) are used for the negative direction of rotation.

Digital inputs

The digital inputs are mapped into the status byte in bit [SB1.0 \[► 48\]](#).

Error indication

The terminal offers the user a variety of diagnostic options. These messages are subdivided into hardware warnings and hardware errors.

Hardware warnings

The functionality of the terminal is retained if one of the following warnings occurs. In the status byte the bit [SB1.5 \[► 48\]](#) (Warning) is set.

- Driver in saturation (Saturated [R0.6 \[► 53\]](#))
 - This bit is set when the largest duty cycle is output (automatically cancelled)
- Overtemperature ([R0.8 \[► 53\]](#))
 - The status bit is set if the internal terminal temperature exceeds 80 °C. It is automatically cancelled if the temperature falls below 80 °C.
- Overload (overcurrent, [R0.9 \[► 53\]](#)) ([R32.9 \[► 56\]](#) = 0)
 - This bit is set if the motor current exceeds the value configured in register [R35 \[► 58\]](#).
 - This bit is set if the motor current exceeds the value configured in register [R41 \[► 58\]](#) or [R49 \[► 59\]](#) when torque limiting is active ([CB1.0 \[► 47\]](#) = 1)
- Undervoltage ([R0.10 \[► 53\]](#))
 - This bit is set if the motor voltage falls below 8 V
- Overvoltage ([R0.11 \[► 53\]](#))
 - This bit is set if the motor voltage exceeds a value that is 10 % greater than the value configured in register [R36 \[► 58\]](#)

If a warning occurs the cause has to be rectified and subsequently acknowledged and thus cancelled by setting bit [CB1.6 \[► 47\]](#) in the control byte (unless specified otherwise above).

Hardware error

The motor power is switched off and bit [SB1.6 \[► 48\]](#) in the status byte is set if one of the following errors occurs.

- Short Circuit ([R0.12 \[► 53\]](#))
- Failure of the 24 V control voltage (No Control Power, [R0.14 \[► 53\]](#))
 - This bit is set if the control voltage falls below 12 V (correct function of the driver stages can no longer be guaranteed if the control voltage is less than 12 V)
 - The terminal is automatically reinitialized when the control voltage returns

- Other errors (Misc Error, [R0.15](#) [[▶ 53](#)]). The following errors are consolidated through this bit:
 - Overtemperature (internal terminal temperature exceeds 100 °C, "Overtemperature" bit is also set),
 - Initialization error (illogical register configuration)
 - Overload (only if [R32.9](#) [[▶ 56](#)] is enabled; set together with [R0.9](#) [[▶ 53](#)])

If an error occurs, it first has to be rectified and subsequently acknowledged and thus cancelled by setting bit [CB1.6](#) [[▶ 47](#)] in the control byte.

3.2 Chopper operation

Instead of a DC motor, you can connect a brake resistor (chopper) to a channel of the KL2532/KL2552 and activate *brake resistor* mode for this channel (see [KS2000](#) [[▶ 42](#)] or registers [R33.0](#) - [R33.3](#) [[▶ 57](#)]).

The motor must actively brake for positioning tasks. The mechanical energy is thereby converted back into electrical energy. Small amounts of energy can be absorbed by a capacitor in the KL2532/KL2552. Further storage capacities, for example in the power supply, can also take up energy. The feedback leads in each case to a voltage increase.

In order to avoid overvoltage, a brake resistor can be connected to the KL2532/KL2552 in order to dissipate the excess energy in the form of heat. When the voltage reaches 110% of the rated voltage (register [R36](#) [[▶ 58](#)], e.g. 55 V for KL2552), the correctly set output stage sends a fast-pulsed current through the brake resistor (see diagram).

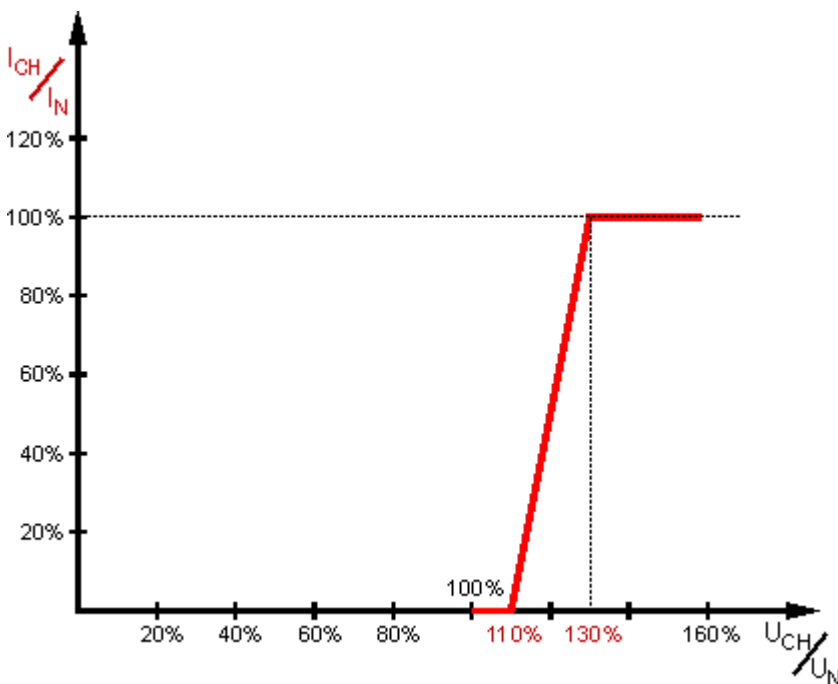

Fig. 6: Current through the brake resistor

U_{CH} / U_N	20%	40%	60%	80%	100%	110%	130%	160%
U_{CH} at $U_N = 50 \text{ V}$	10 V	20 V	30 V	40 V	50 V	55 V	65 V	80 V
U_{CH} at $U_N = 24 \text{ V}$	4,8 V	9,6 V	14,4 V	19,2 V	24 V	25,2 V	31,2 V	38,4 V

NOTE

Dimensioning of the brake resistor

The brake resistor should be dimensioned such that it can withstand the expected heat development without damage!

A brake resistance of 10 Ω is recommended for KL2552, which results in a pulse current of approx. 5.5 A to 6.5 A. The maximum expected continuous power is 125 W. However, the value typically lies significantly below that.

Load estimation (for KL2552)

$$P_N = I_N^2 \times R$$

$$P_N = (5A)^2 \times 10 \Omega$$

$$P_N = 250 \text{ W}$$

A maximum duty cycle of 50 % is possible. This results in a maximum continuous power of 125 W.

A motor efficiency of 80 % is usual in practice.

The motor thus converts 80 % of the rated electrical power into kinetic energy when accelerating.

Conversely, when braking, the motor (as a generator) converts 80 % of the kinetic energy into electrical power.

This results in a practical brake power of:

$$P_{CH} = P_N/2 \times 80/100 \times 80/100$$

$$P_{CH} = 125W \times 80/100 \times 80/100$$

$$P_{CH} = 80 \text{ W}$$

4 Mounting and wiring

4.1 Instructions for ESD protection

NOTE

Destruction of the devices by electrostatic discharge possible!

The devices contain components at risk from electrostatic discharge caused by improper handling.

- Please ensure you are electrostatically discharged and avoid touching the contacts of the device directly.
- Avoid contact with highly insulating materials (synthetic fibers, plastic film etc.).
- Surroundings (working place, packaging and personnel) should be grounded probably, when handling with the devices.
- Each assembly must be terminated at the right hand end with a KL9010 bus end terminal, to ensure the protection class and ESD protection.

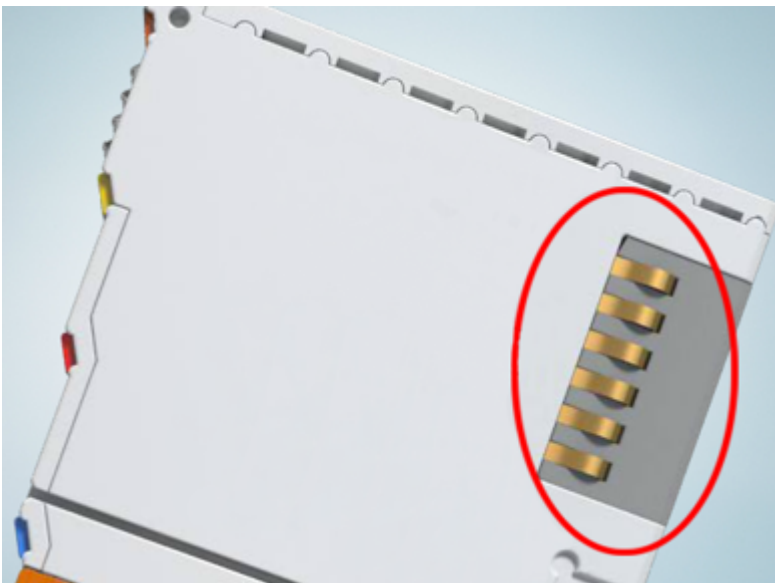

Fig. 7: Spring contacts of the Beckhoff I/O components

4.2 Installation on mounting rails

⚠ WARNING

Risk of electric shock and damage of device!

Bring the bus terminal system into a safe, powered down state before starting installation, disassembly or wiring of the bus terminals!

Assembly

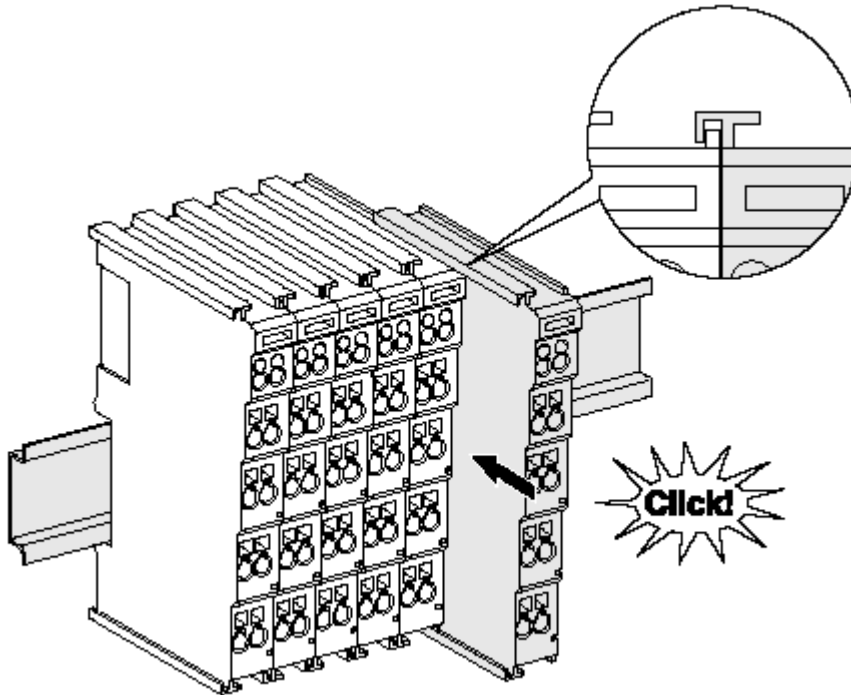

Fig. 8: Attaching on mounting rail

The bus coupler and bus terminals are attached to commercially available 35 mm mounting rails (DIN rails according to EN 60715) by applying slight pressure:

1. First attach the fieldbus coupler to the mounting rail.
2. The bus terminals are now attached on the right-hand side of the fieldbus coupler. Join the components with tongue and groove and push the terminals against the mounting rail, until the lock clicks onto the mounting rail.

If the terminals are clipped onto the mounting rail first and then pushed together without tongue and groove, the connection will not be operational! When correctly assembled, no significant gap should be visible between the housings.

i Fixing of mounting rails

The locking mechanism of the terminals and couplers extends to the profile of the mounting rail. At the installation, the locking mechanism of the components must not come into conflict with the fixing bolts of the mounting rail. To mount the mounting rails with a height of 7.5 mm under the terminals and couplers, you should use flat mounting connections (e.g. countersunk screws or blind rivets).

Disassembly

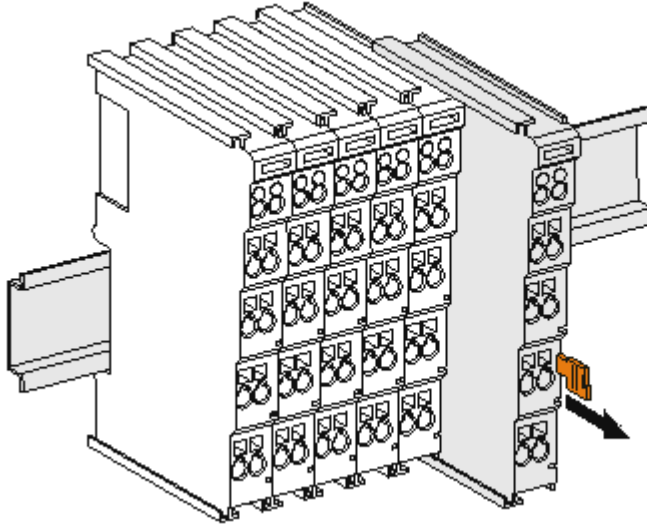

Fig. 9: Disassembling of terminal

Each terminal is secured by a lock on the mounting rail, which must be released for disassembly:

1. Pull the terminal by its orange-colored lugs approximately 1 cm away from the mounting rail. In doing so for this terminal the mounting rail lock is released automatically and you can pull the terminal out of the bus terminal block easily without excessive force.
2. Grasp the released terminal with thumb and index finger simultaneous at the upper and lower grooved housing surfaces and pull the terminal out of the bus terminal block.

Connections within a bus terminal block

The electric connections between the Bus Coupler and the Bus Terminals are automatically realized by joining the components:

- The six spring contacts of the K-Bus/E-Bus deal with the transfer of the data and the supply of the Bus Terminal electronics.
- The power contacts deal with the supply for the field electronics and thus represent a supply rail within the bus terminal block. The power contacts are supplied via terminals on the Bus Coupler (up to 24 V) or for higher voltages via power feed terminals.

i Power Contacts

During the design of a bus terminal block, the pin assignment of the individual Bus Terminals must be taken account of, since some types (e.g. analog Bus Terminals or digital 4-channel Bus Terminals) do not or not fully loop through the power contacts. Power Feed Terminals (KL91xx, KL92xx or EL91xx, EL92xx) interrupt the power contacts and thus represent the start of a new supply rail.

PE power contact

The power contact labeled PE can be used as a protective earth. For safety reasons this contact mates first when plugging together, and can ground short-circuit currents of up to 125 A.

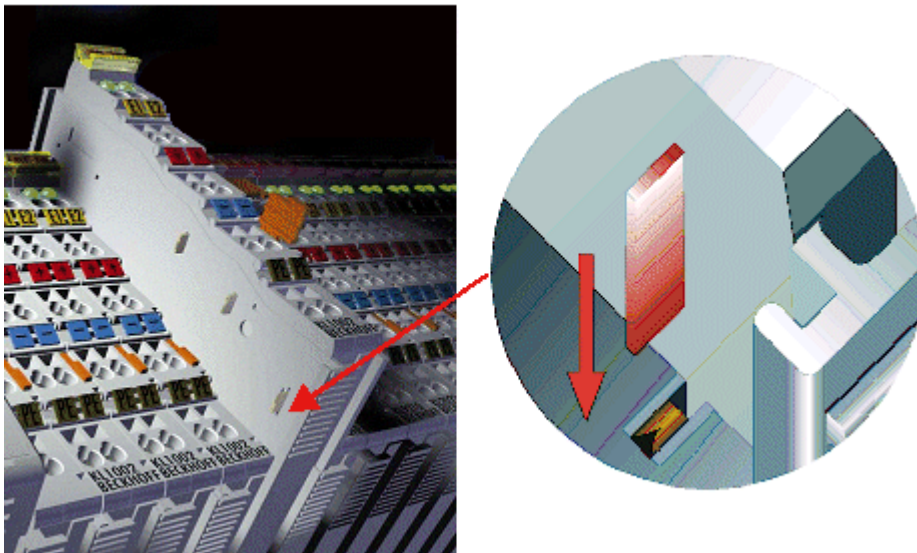

Fig. 10: Power contact on left side

NOTE

Possible damage of the device

Note that, for reasons of electromagnetic compatibility, the PE contacts are capacitatively coupled to the mounting rail. This may lead to incorrect results during insulation testing or to damage on the terminal (e.g. disruptive discharge to the PE line during insulation testing of a consumer with a nominal voltage of 230 V). For insulation testing, disconnect the PE supply line at the Bus Coupler or the Power Feed Terminal! In order to decouple further feed points for testing, these Power Feed Terminals can be released and pulled at least 10 mm from the group of terminals.

⚠ WARNING

Risk of electric shock!

The PE power contact must not be used for other potentials!

4.3 Installation instructions for enhanced mechanical load capacity

⚠ WARNING

Risk of injury through electric shock and damage to the device!

Bring the Bus Terminal system into a safe, de-energized state before starting mounting, disassembly or wiring of the Bus Terminals!

Additional checks

The terminals have undergone the following additional tests:

Verification	Explanation
Vibration	10 frequency runs in 3 axes
	6 Hz < f < 60 Hz displacement 0.35 mm, constant amplitude
	60.1 Hz < f < 500 Hz acceleration 5 g, constant amplitude
Shocks	1000 shocks in each direction, in 3 axes
	25 g, 6 ms

Additional installation instructions

For terminals with enhanced mechanical load capacity, the following additional installation instructions apply:

- The enhanced mechanical load capacity is valid for all permissible installation positions
- Use a mounting rail according to EN 60715 TH35-15
- Fix the terminal segment on both sides of the mounting rail with a mechanical fixture, e.g. an earth terminal or reinforced end clamp
- The maximum total extension of the terminal segment (without coupler) is: 64 terminals (12 mm mounting with) or 32 terminals (24 mm mounting with)
- Avoid deformation, twisting, crushing and bending of the mounting rail during edging and installation of the rail
- The mounting points of the mounting rail must be set at 5 cm intervals
- Use countersunk head screws to fasten the mounting rail
- The free length between the strain relief and the wire connection should be kept as short as possible. A distance of approx. 10 cm should be maintained to the cable duct.

4.4 Installation position for operation with or without fan

NOTE

Constraints regarding installation position and operating temperature range

When installing the terminals ensure that an adequate spacing is maintained between other components above and below the terminal in order to guarantee adequate ventilation!

Prescribed installation position for operation without fan

The prescribed installation position requires the mounting rail to be installed horizontally and the connection surfaces of the EL/KL terminals to face forward (see Fig. “*Recommended distances of installation position for operating without fan*”).

The terminals are ventilated from below, which enables optimum cooling of the electronics through convection.

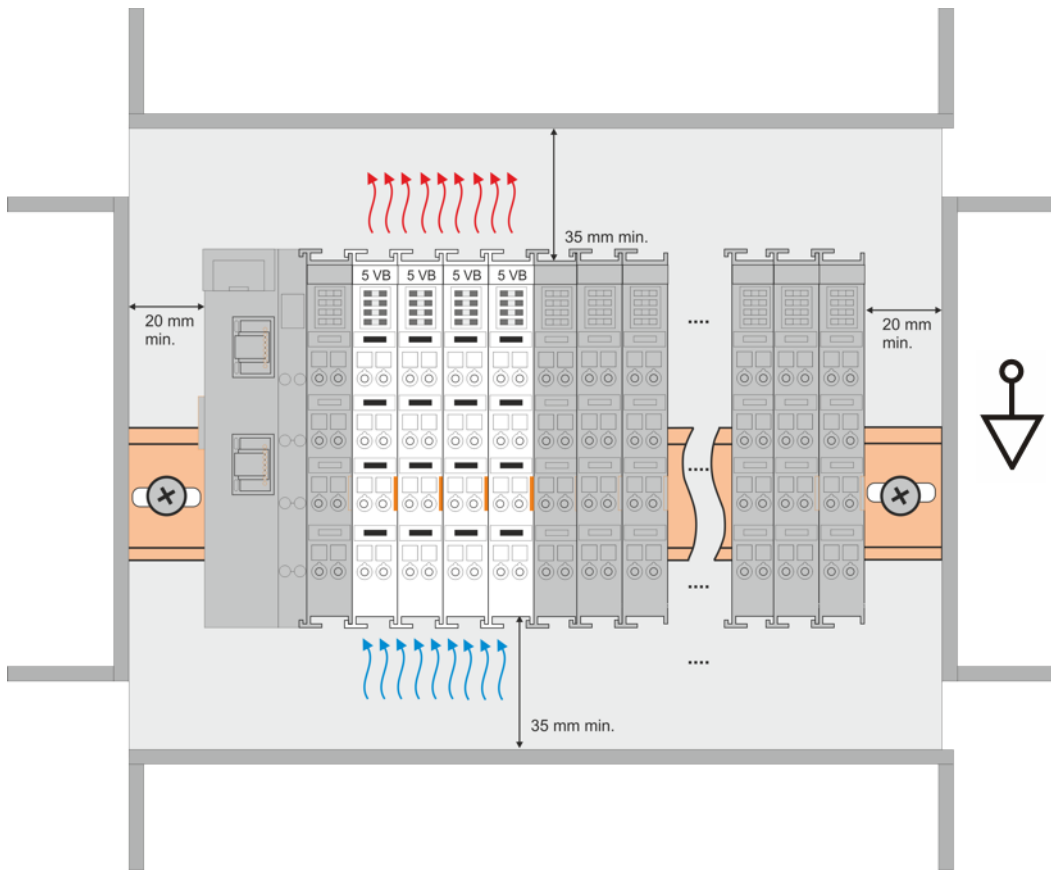

Fig. 11: Recommended distances of installation position for operating without fan

Compliance with the distances shown in Fig. “Recommended distances of installation position for operating without fan” is recommended.

For further information regarding the operation without fan refer to the Technical Data of the terminal.

Standard installation position for operation with fan

The standard installation position for operation with fan requires the mounting rail to be installed horizontally and the connection surfaces of the EL/KL terminals to face forward (see Fig. *Recommended distances for installation position for operation with fan*).

The terminals are ventilated fan supported (e.g. with [fan cartridge ZB8610](#)) from below.

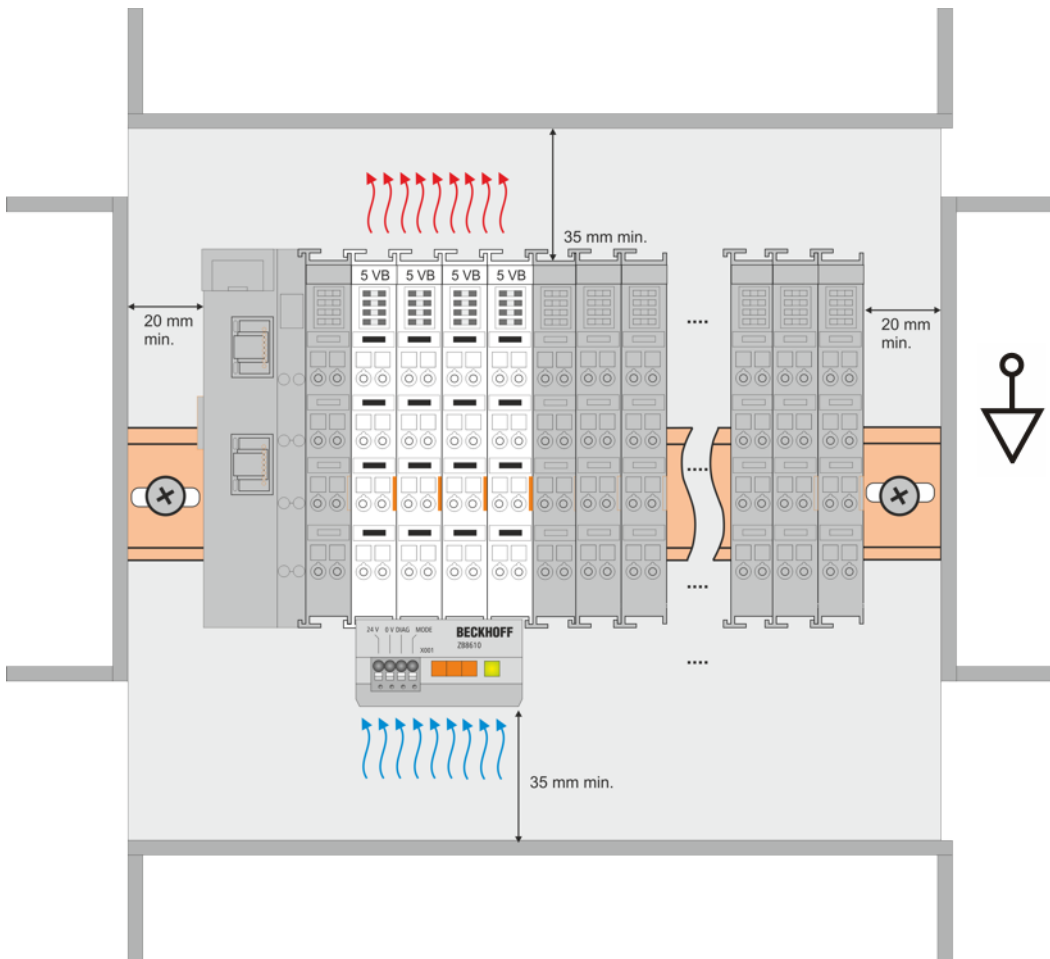

Fig. 12: Recommended distances for installation position for operation with fan

Other installation positions

Due to the enforced effect of the fan on the ventilation of the terminals, other installation positions (see Fig. "Other installation positions, example 1 + 2") may be permitted where appropriate.

See corresponding notes in the Technical Data of the terminal.

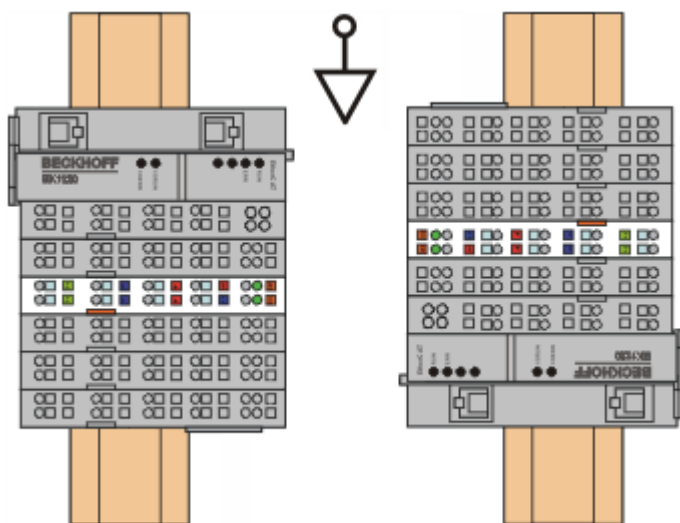

Fig. 13: Other installation positions, example 1

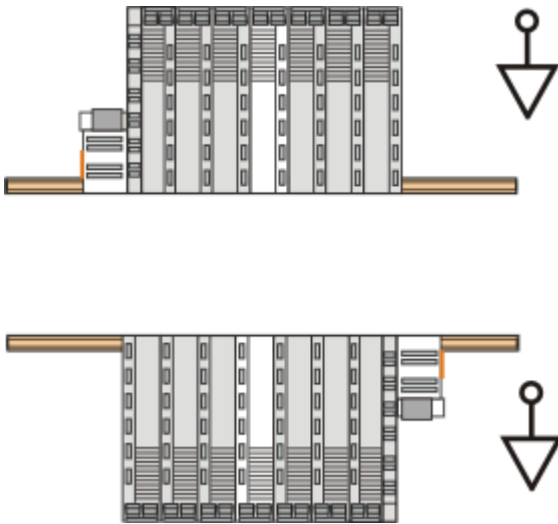

Fig. 14: Other installation positions, example 2

4.5 Connection

4.5.1 Connection system

⚠ WARNING

Risk of electric shock and damage of device!

Bring the bus terminal system into a safe, powered down state before starting installation, disassembly or wiring of the bus terminals!

Overview

The bus terminal system offers different connection options for optimum adaptation to the respective application:

- The terminals of ELxxxx and KLxxxx series with standard wiring include electronics and connection level in a single enclosure.
- The terminals of ESxxxx and KSxxxx series feature a pluggable connection level and enable steady wiring while replacing.
- The High Density Terminals (HD Terminals) include electronics and connection level in a single enclosure and have advanced packaging density.

Standard wiring (ELxxxx / KLxxxx)



Fig. 15: Standard wiring

The terminals of ELxxxx and KLxxxx series have been tried and tested for years. They feature integrated screwless spring force technology for fast and simple assembly.

Pluggable wiring (ESxxxx / KSxxxx)



Fig. 16: Pluggable wiring

The terminals of ESxxxx and KSxxxx series feature a pluggable connection level. The assembly and wiring procedure is the same as for the ELxxxx and KLxxxx series. The pluggable connection level enables the complete wiring to be removed as a plug connector from the top of the housing for servicing. The lower section can be removed from the terminal block by pulling the unlocking tab. Insert the new component and plug in the connector with the wiring. This reduces the installation time and eliminates the risk of wires being mixed up.

The familiar dimensions of the terminal only had to be changed slightly. The new connector adds about 3 mm. The maximum height of the terminal remains unchanged.

A tab for strain relief of the cable simplifies assembly in many applications and prevents tangling of individual connection wires when the connector is removed.

Conductor cross sections between 0.08 mm² and 2.5 mm² can continue to be used with the proven spring force technology.

The overview and nomenclature of the product names for ESxxxx and KSxxxx series has been retained as known from ELxxxx and KLxxxx series.

High Density Terminals (HD Terminals)



Fig. 17: High Density Terminals

The terminals from these series with 16 terminal points are distinguished by a particularly compact design, as the packaging density is twice as large as that of the standard 12 mm bus terminals. Massive conductors and conductors with a wire end sleeve can be inserted directly into the spring loaded terminal point without tools.

● Wiring HD Terminals

i The High Density Terminals of the ELx8xx and KLx8xx series doesn't support pluggable wiring.

Ultrasonically "bonded" (ultrasonically welded) conductors

● Ultrasonically "bonded" conductors

i It is also possible to connect the Standard and High Density Terminals with ultrasonically "bonded" (ultrasonically welded) conductors. In this case, please note the tables concerning the wire-size width!

4.5.2 Wiring

⚠ WARNING

Risk of electric shock and damage of device!

Bring the bus terminal system into a safe, powered down state before starting installation, disassembly or wiring of the bus terminals!

Terminals for standard wiring ELxxxx/KLxxxx and for pluggable wiring ESxxxx/KSxxxx

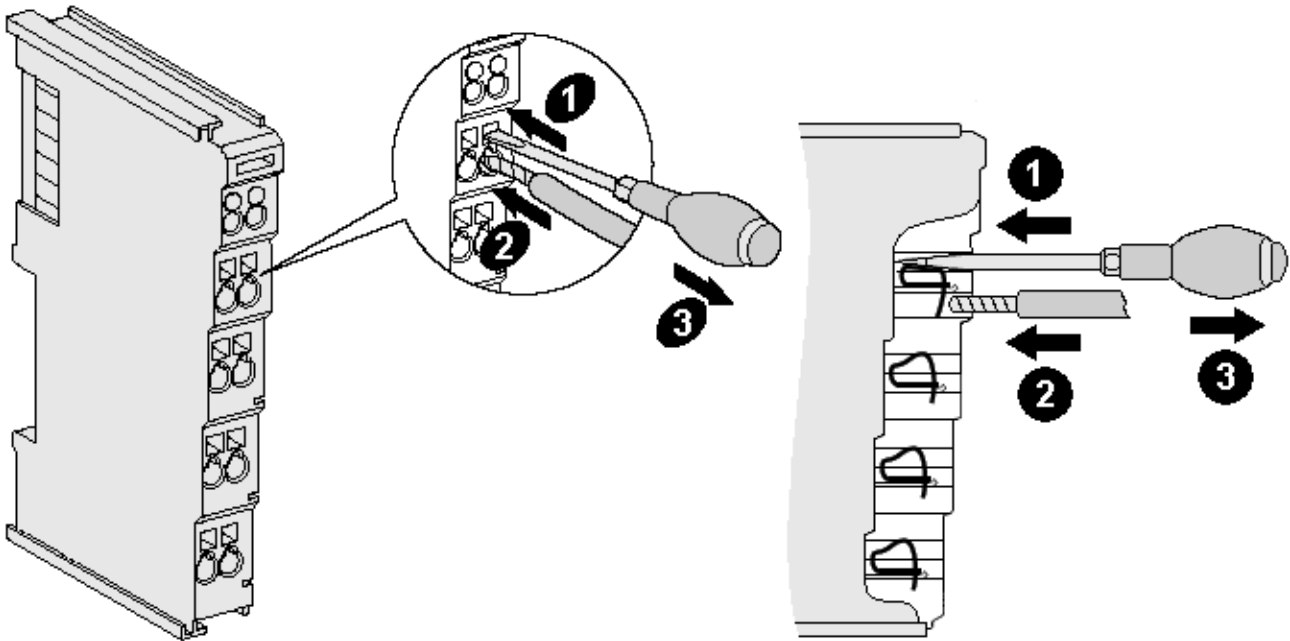

Fig. 18: Connecting a cable on a terminal point

Up to eight terminal points enable the connection of solid or finely stranded cables to the bus terminal. The terminal points are implemented in spring force technology. Connect the cables as follows:

1. Open a terminal point by pushing a screwdriver straight against the stop into the square opening above the terminal point. Do not turn the screwdriver or move it alternately (don't toggle).
2. The wire can now be inserted into the round terminal opening without any force.
3. The terminal point closes automatically when the pressure is released, holding the wire securely and permanently.

See the following table for the suitable wire size width.

Terminal housing	ELxxxx, KLxxxx	ESxxxx, KSxxxx
Wire size width (single core wires)	0.08 ... 2.5 mm ²	0.08 ... 2.5 mm ²
Wire size width (fine-wire conductors)	0.08 ... 2.5 mm ²	0,08 ... 2.5 mm ²
Wire size width (conductors with a wire end sleeve)	0.14 ... 1.5 mm ²	0.14 ... 1.5 mm ²
Wire stripping length	8 ... 9 mm	9 ... 10 mm

High Density Terminals (HD Terminals [▶ 28]) with 16 terminal points

The conductors of the HD Terminals are connected without tools for single-wire conductors using the direct plug-in technique, i.e. after stripping the wire is simply plugged into the terminal point. The cables are released, as usual, using the contact release with the aid of a screwdriver. See the following table for the suitable wire size width.

Terminal housing	High Density Housing
Wire size width (single core wires)	0.08 ... 1.5 mm ²
Wire size width (fine-wire conductors)	0.25 ... 1.5 mm ²
Wire size width (conductors with a wire end sleeve)	0.14 ... 0.75 mm ²
Wire size width (ultrasonically "bonded" conductors)	only 1.5 mm ²
Wire stripping length	8 ... 9 mm





4.5.3 Shielding



Shielding

Encoder, analog sensors and actors should always be connected with shielded, twisted paired wires.

4.6 UL notice - Compact Motion

	<p>Application</p> <p>Beckhoff EtherCAT modules are intended for use with Beckhoff's UL Listed EtherCAT System only.</p>
	<p>Examination</p> <p>For cULus examination, the Beckhoff I/O System has only been investigated for risk of fire and electrical shock (in accordance with UL508 and CSA C22.2 No. 142).</p>
	<p>For devices with Ethernet connectors</p> <p>Not for connection to telecommunication circuits.</p>
	<p>Notes on motion devices</p> <ul style="list-style-type: none"> • <i>Motor overtemperature</i> Motor overtemperature sensing is not provided by the drive. • <i>Application for compact motion devices</i> The modules are intended for use only within Beckhoff's Programmable Controller system Listed in File E172151. • <i>Galvanic isolation from the supply</i> The modules are intended for operation within circuits not connected directly to the supply mains (galvanically isolated from the supply, i.e. on transformer secondary). • <i>Requirement for environmental conditions</i> For use in Pollution Degree 2 Environment only.

Basic principles

UL certification according to UL508. Devices with this kind of certification are marked by this sign:



Application

If terminals certified *with restrictions* are used, then the current consumption at 24 V_{DC} must be limited accordingly by means of supply

- from an isolated source protected by a fuse of max. 4 A (according to UL248) or

- from a voltage supply complying with *NEC class 2*.
A voltage source complying with *NEC class 2* may not be connected in series or parallel with another *NEC class 2* compliant voltage supply!

These requirements apply to the supply of all EtherCAT bus couplers, power adaptor terminals, Bus Terminals and their power contacts.

4.7 KL2532/KS2532 - connection

⚠ WARNING

Risk of injury through electric shock and damage to the device!

Bring the Bus Terminals system into a safe, de-energized state before starting mounting, disassembly or wiring of the Bus Terminals.

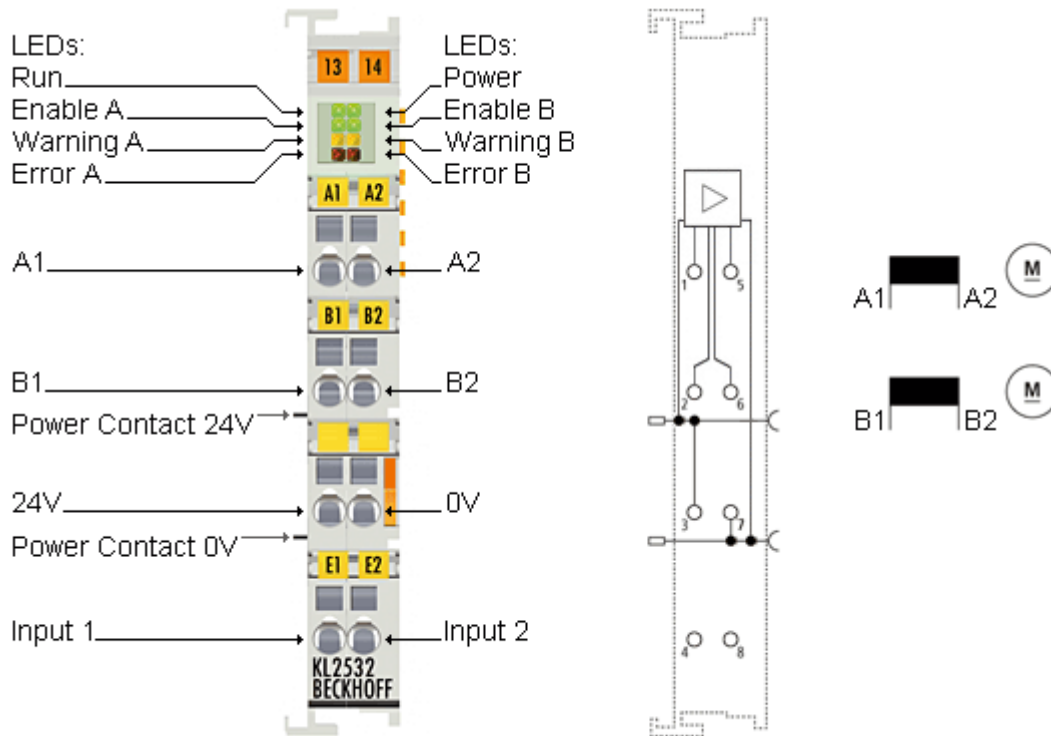

Fig. 19: KL2532/KS2532 pin assignment

Terminal point	No.	Connection for
A1	1	Motor A, connection A1
B1	2	Motor B, connection B1
24 V	3	e.g. encoder supply (for positive power contact)
Input 1	4	Digital input 1 (24 V _{DC}). The current counter value is saved as a reference mark in the latch register if bit <u>CB.1</u> [▶ 47] is set in the control word and a rising edge occurs at digital input 1.
A2	5	Motor A, connection A2
B2	6	Motor B, connection B2
0 V	7	e.g. encoder supply (for negative power contact)
Input 2	8	Digital input 2 (24 V _{DC}). The current counter value is saved as a reference mark in the latch register if bit <u>CB.2</u> [▶ 49] is set in the control word and a rising edge occurs at digital input 2.

4.8 KL2552-0000/KS2552-0000 - connection

⚠ WARNING

Risk of injury through electric shock and damage to the device!

Bring the Bus Terminals system into a safe, de-energized state before starting mounting, disassembly or wiring of the Bus Terminals.

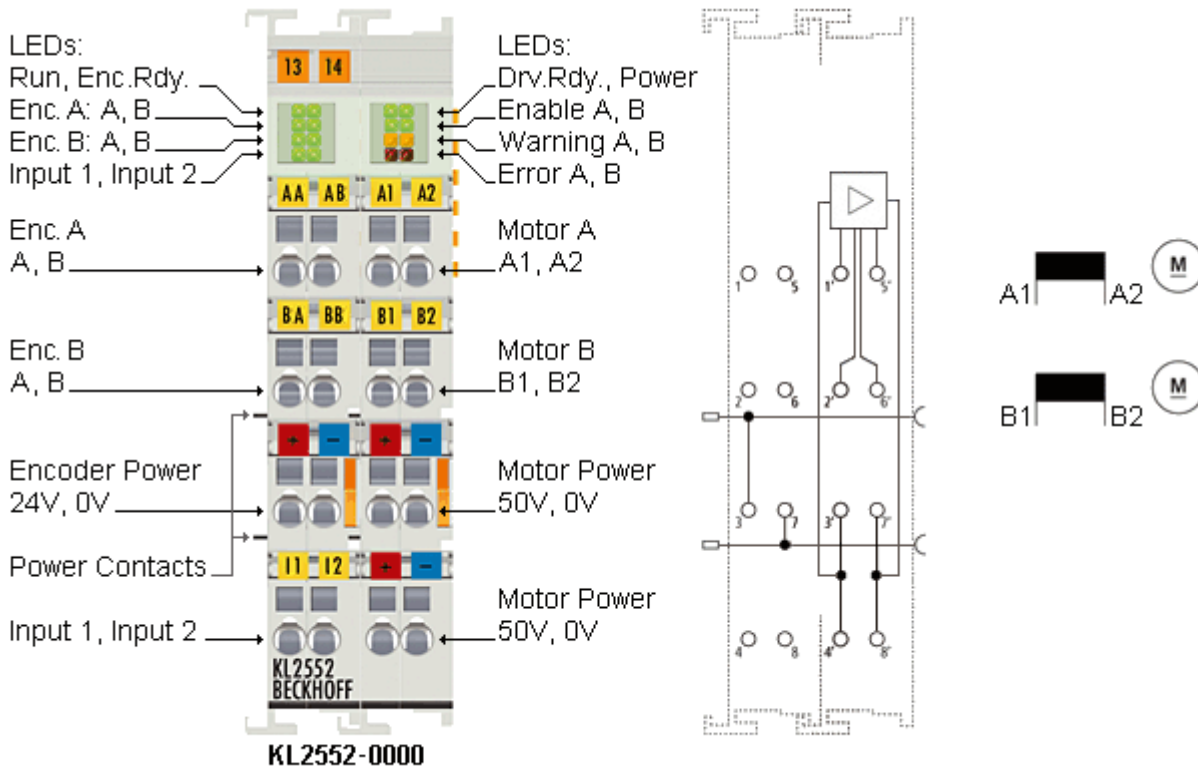

Fig. 20: KL2552/KS2552 pin assignment

Terminal points

Left-hand section of the housing

Terminal point	No.	Connection for
Encoder A, A	1	Encoder A, connection A
Encoder B, A	2	Encoder B, connection A
Encoder Power +24 V	3	Encoder supply (from positive power contact)
Input 1	4	Digital input 1 (24 V _{DC}). The current counter value is stored as reference mark in the latch register, if bit <u>CB1.1</u> [▶ 47] is set in control byte 1 and a rising edge occurs at digital input 1.
Encoder A, B	5	Encoder A, connection B
Encoder B, B	6	Encoder B, connection B
Encoder Power 0 V	7	Encoder supply (from negative power contact)
Input 2	8	Digital input 2 (24 V _{DC}). The current counter value is stored as reference mark in the latch register, if bit <u>CB2.1</u> [▶ 49] is set in control byte 2 and a rising edge occurs at digital input 2.

Right-hand section of the housing

Terminal point	No.	Connection for
Motor A, A1	1'	Motor A, connection A1
Motor B, B1	2'	Motor B, connection B1
Power Motor 50 V	3'	Motor supply feed (maximum +50 V _{DC})
Power Motor 50 V	4'	Motor supply feed (maximum +50 V _{DC})
Motor A, A2	5'	Motor A, connection A2
Motor B, B2	6'	Motor B, connection B2
Power Motor 0 V	7'	Motor supply feed (0 V _{DC})
Power Motor 0 V	8'	Motor supply feed (0 V _{DC})

Power contacts

The voltage Up of the power contacts (+24 V_{DC}) supplies the following consumers:

- Incremental encoder (terminal points 3 and 7)
- Digital inputs (terminal points 4 and 8)
- Output driver of the DC motor output stage

4.9 KL2552-0005/KS2552-0005 - connection

⚠ WARNING

Risk of injury!

Bring the Bus Terminals system into a safe, de-energized state before starting mounting, disassembly or wiring of the Bus Terminals.

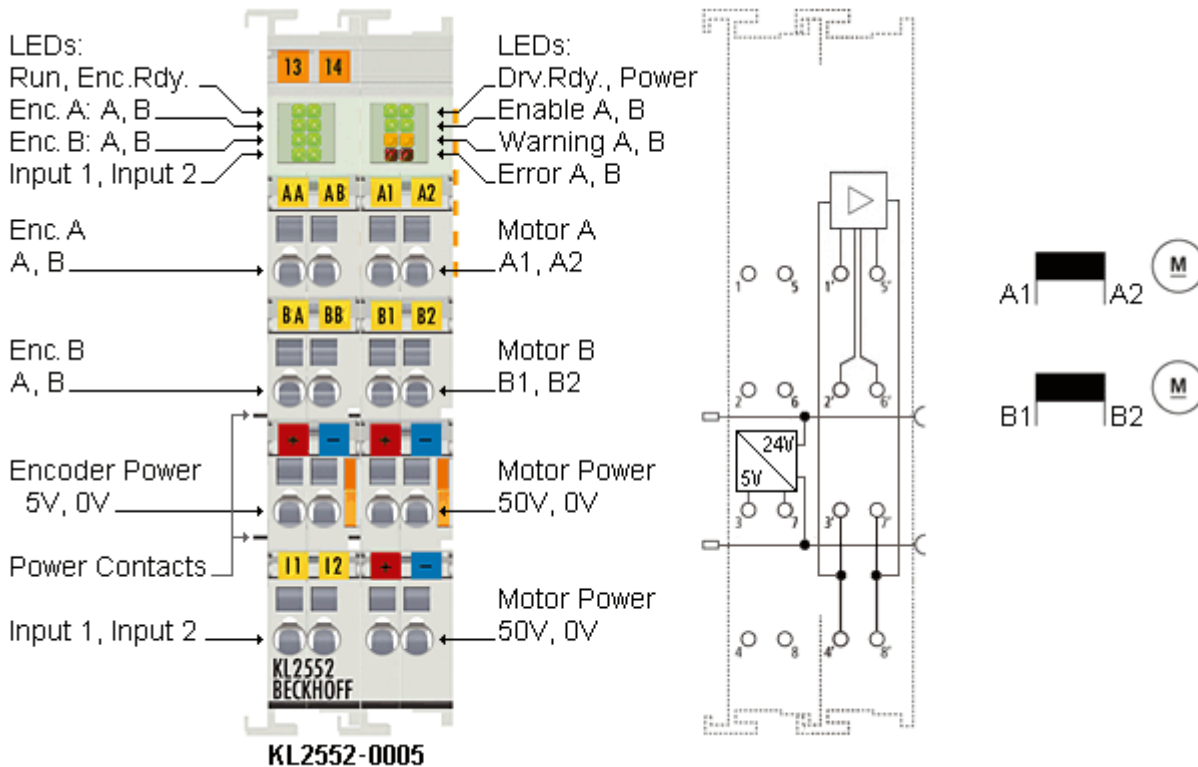

Fig. 21: KL2552-0005/KS2552-0005 pin assignment

Terminal points

Left-hand section of the housing

Terminal point	No.	Connection for
Encoder A, A	1	Encoder A, connection A
Encoder B, A	2	Encoder B, connection A
Encoder Power +5 V	3	Encoder supply (via switching controller of positive power contact)
Input 1	4	Digital input 1 (24 V _{DC}). The current counter value is stored as reference mark in the latch register, if bit CB1.1 [▶ 47] is set in control byte 1 and a rising edge occurs at digital input 1.
Encoder A, B	5	Encoder A, connection B
Encoder B, B	6	Encoder B, connection B
Encoder Power 0 V	7	Encoder supply (via switching controller of negative power contact)
Input 2	8	Digital input 2 (24 V _{DC}). The current counter value is stored as reference mark in the latch register, if bit CB2.1 [▶ 49] is set in control byte 2 and a rising edge occurs at digital input 2.

Right-hand section of the housing

Terminal point	No.	Connection for
Motor A, A1	1'	Motor A, connection A1
Motor B, B1	2'	Motor B, connection B1
Power Motor 50 V	3'	Motor supply feed (maximum +50 V _{DC})
Power Motor 50 V	4'	Motor supply feed (maximum +50 V _{DC})
Motor A, A2	5'	Motor A, connection A2
Motor B, B2	6'	Motor B, connection B2
Power Motor 0 V	7'	Motor supply feed (0 V _{DC})
Power Motor 0 V	8'	Motor supply feed (0 V _{DC})

Power contacts

The voltage Up of the power contacts (+24 V_{DC}) supplies the following consumers:

- Incremental encoder (terminal points 3 and 7)
- Digital inputs (terminal points 4 and 8)
- Output driver of the DC motor output stage

4.10 KL2552 - application example

⚠ WARNING

Risk of injury through electric shock and damage to the device!

Bring the Bus Terminals system into a safe, de-energized state before starting mounting, disassembly or wiring of the Bus Terminals.

Brake resistor

The brake resistor connected to channel 2 of the second EL7342 uses the brake energy of the motors connected to the other three channels.

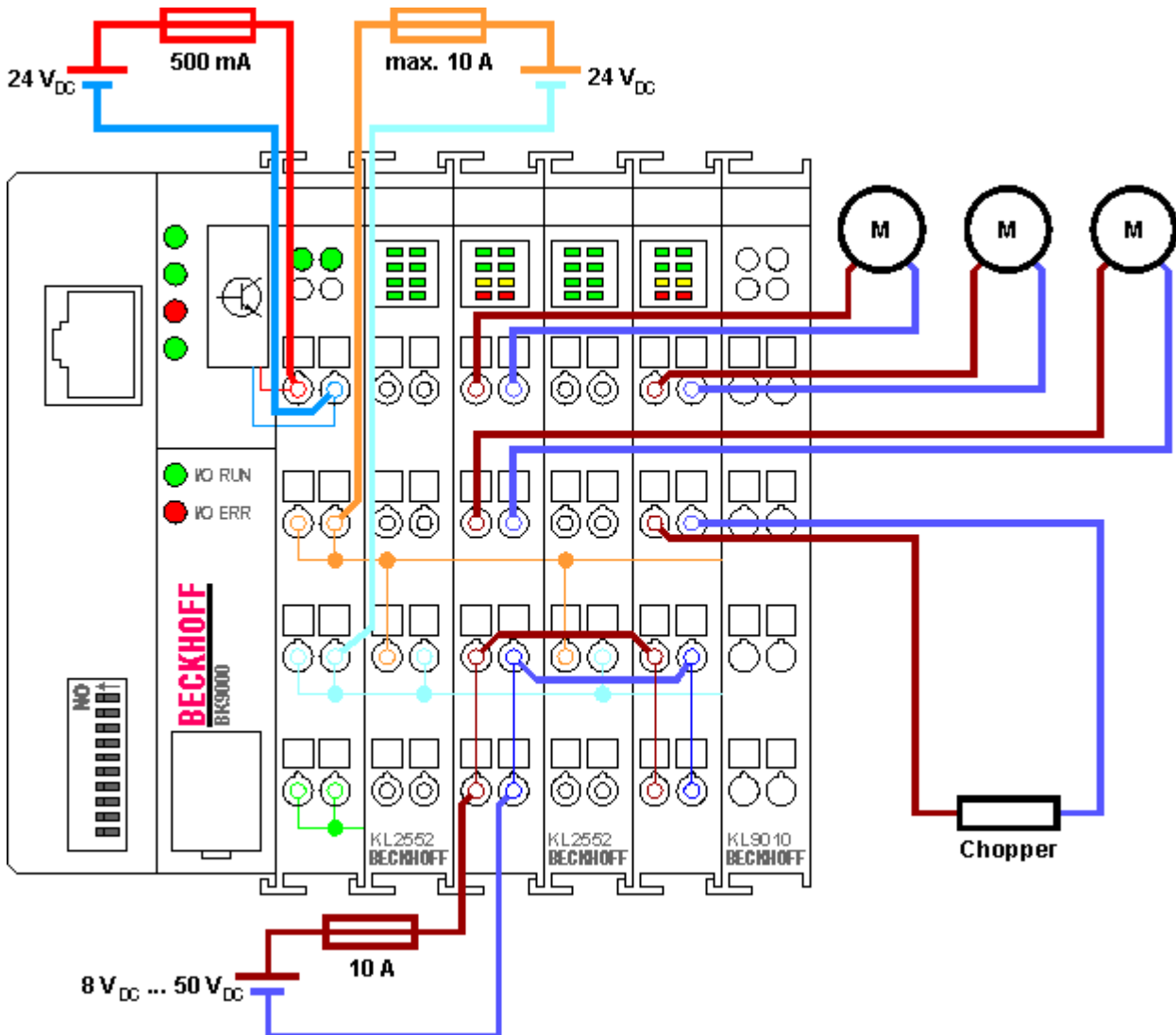

Fig. 22: KL2552 application example

NOTE

Dimensioning of the brake resistor

The brake resistor should be dimensioned such that it can withstand the expected heat development without damage!

5 Configuration software KS2000

5.1 KS2000 - Introduction

The KS2000 configuration software permits configuration, commissioning and parameterization of bus couplers, of the affiliated bus terminals and of Fieldbus Box Modules. The connection between bus coupler / Fieldbus Box Module and the PC is established by means of the serial configuration cable or the fieldbus.



Fig. 23: KS2000 configuration software

Configuration

You can configure the Fieldbus stations with the Configuration Software KS2000 offline. That means, setting up a terminal station with all settings on the couplers and terminals resp. the Fieldbus Box Modules can be prepared before the commissioning phase. Later on, this configuration can be transferred to the terminal station in the commissioning phase by means of a download. For documentation purposes, you are provided with the breakdown of the terminal station, a parts list of modules used and a list of the parameters you have modified. After an upload, existing fieldbus stations are at your disposal for further editing.

Parameterization

KS2000 offers simple access to the parameters of a fieldbus station: specific high-level dialogs are available for all bus couplers, all intelligent bus terminals and Fieldbus Box modules with the aid of which settings can be modified easily. Alternatively, you have full access to all internal registers of the bus couplers and intelligent terminals. Refer to the register description for the meanings of the registers.

Commissioning

The KS2000 software facilitates commissioning of machine components or their fieldbus stations: Configured settings can be transferred to the fieldbus modules by means of a download. After a *login* to the terminal station, it is possible to define settings in couplers, terminals and Fieldbus Box modules directly *online*. The same high-level dialogs and register access are available for this purpose as in the configuration phase.

The KS2000 offers access to the process images of the bus couplers and Fieldbus Box modules.

- Thus, the coupler's input and output images can be observed by monitoring.
- Process values can be specified in the output image for commissioning of the output modules.

All possibilities in the *online mode* can be used in parallel with the actual fieldbus mode of the terminal station. The fieldbus protocol always has the higher priority in this case.

5.2 Parameterization with KS2000

Connect the configuration interface of your fieldbus coupler with the serial interface of your PC via the configuration cable and start the *KS2000* configuration software.



Click on the *Login* button. The configuration software will now load the information for the connected fieldbus station.

In the example shown, this is

- A Bus Coupler for Ethernet BK9000
- a KL1xx2 digital input terminal
- a two-channel KL2552 DC motor output stage
- a KL9010 bus end terminal

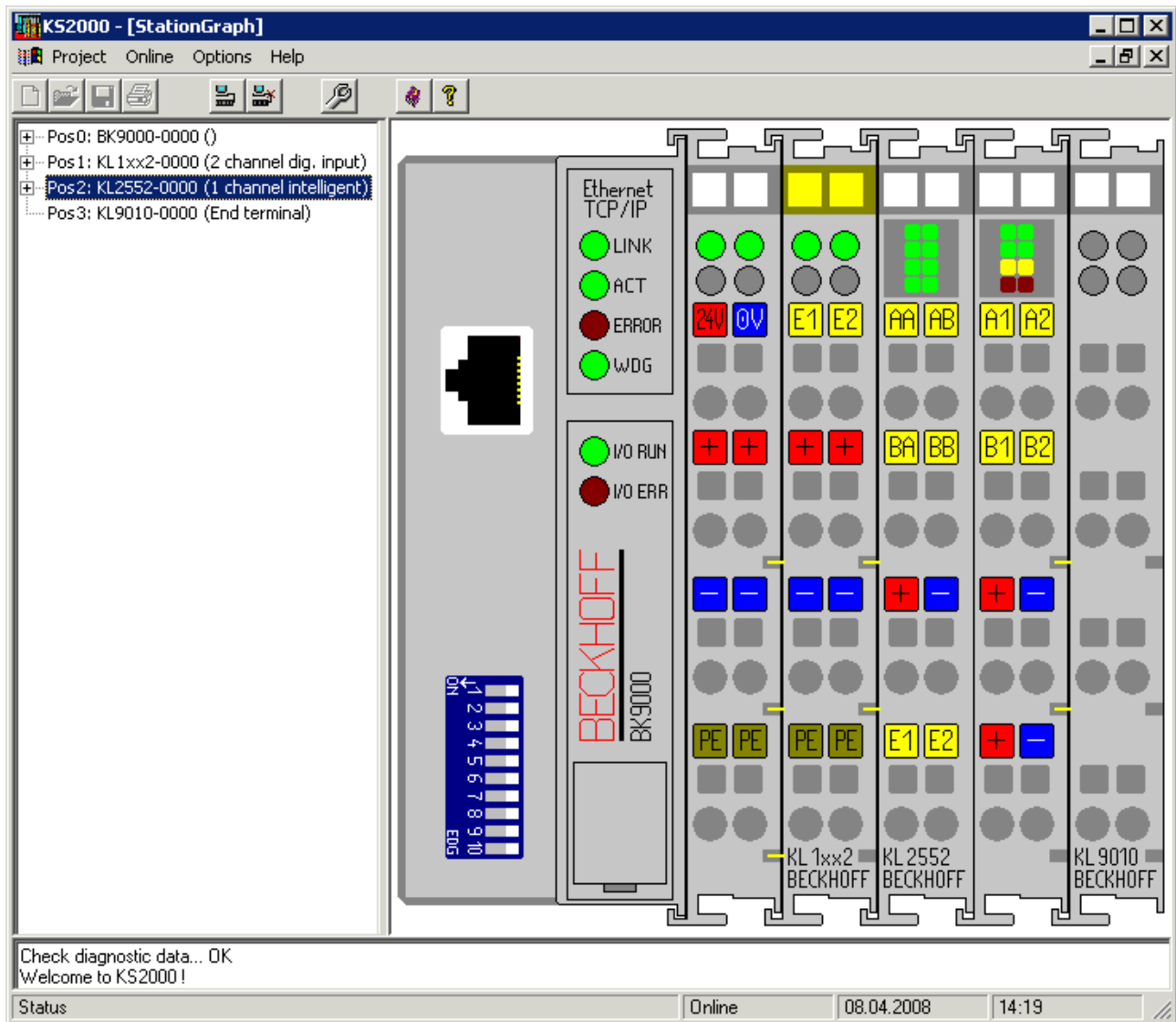

Fig. 24: Display of the fieldbus station in KS2000

The left-hand KS2000 window displays the terminals of the fieldbus station in a tree structure. The right-hand KS2000 window contains a graphic display of the fieldbus station terminals.

In the tree structure of the left-hand window, click on the plus-sign next to the terminal whose parameters you wish to change (item 2 in the example).

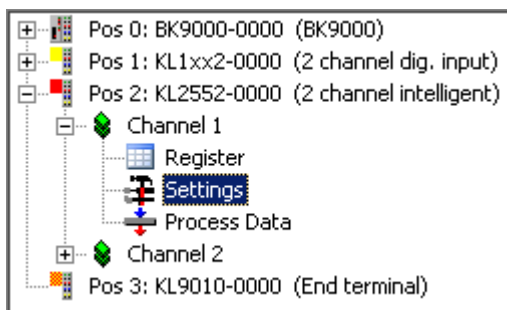

Fig. 25: KS2000 tree branches for channel 1 of the KL2552

For the KL2532, the branches *Register*, *Settings* and *ProcData* are displayed:

- [Register \[► 41\]](#) permits direct access to the registers of the KL2552.
- Under [Settings \[► 42\]](#) you find dialog boxes for parameterizing the KL2552.
- [ProcData \[► 45\]](#) displays the KL2552 process data.

5.3 Register

You can access the registers of the KL2552 directly under *Register*. The meaning of the register is explained in the [register overview](#) [► 50].

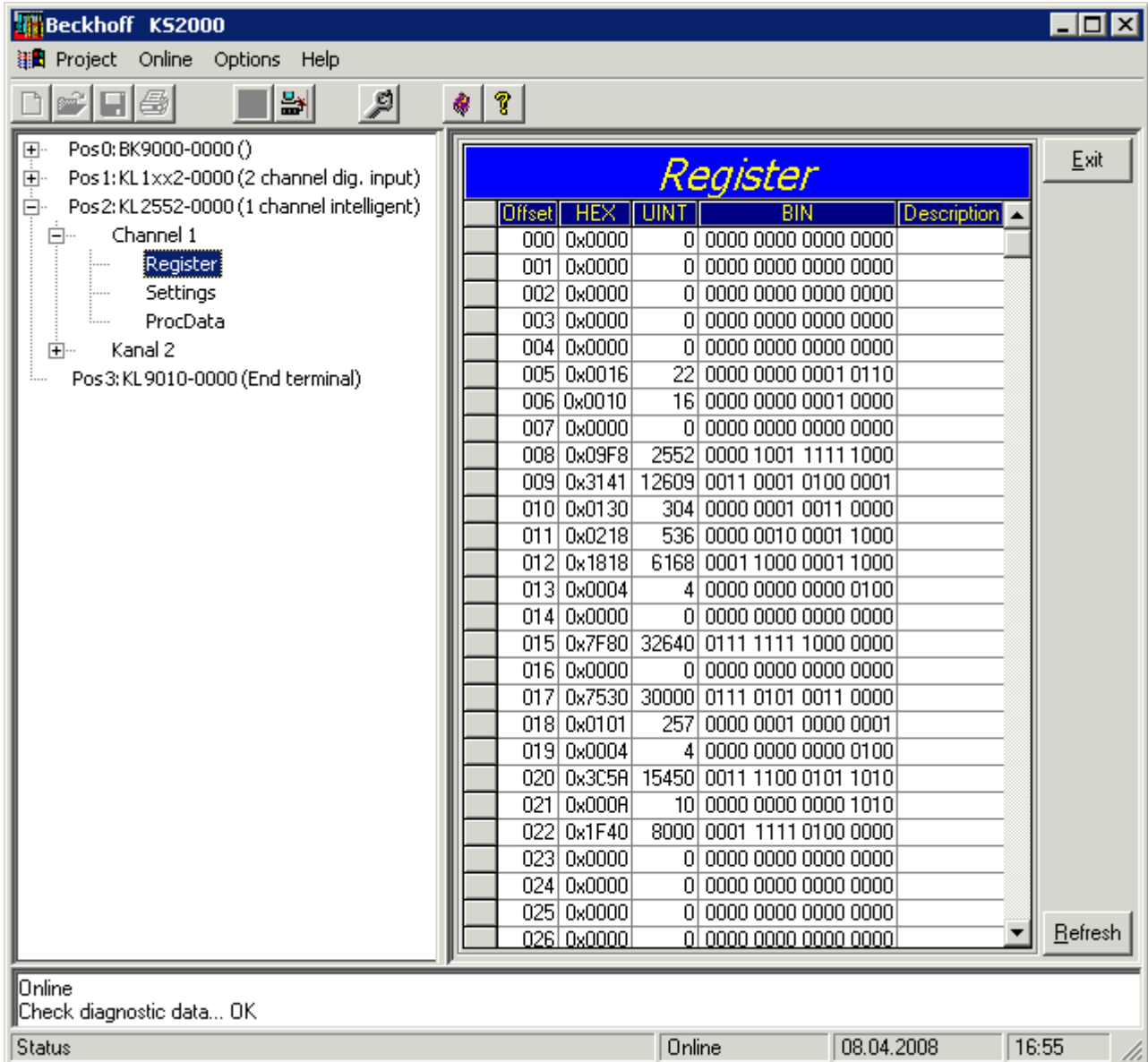

Fig. 26: Register view in KS2000

5.4 Settings

KL2552 parameterization settings.

Pos.: 2 Channel: 1 Firmware: Version 1 M
Type: KL2552-0000

Take settings for all channels of this terminal

Operation mode: speed, direct

Encoder: Input filter active
Increments per revolution: 0

General: Watchdog timer active
 Automatic current reduction active
 Automatic overload switch-off active

Speed controller: Kp factor: 0,100
Ki factor: 0,000
 Inner window active: 0 %
 Outer window active: 0 %
Ka factor: 0,100
Kd factor: 0,000

Motor data: Maximum motor current: 8000 mA
Reduced motor current (pos. direction): 2500 mA
Reduced current threshold (pos. direction): 100 %
Reduced motor current (neg. direction): 2500 mA
Reduced current threshold (neg. direction): 100 %
Nominal motor current: 5000 mA
Nominal motor voltage: 50,00 V
Nominal motor speed: 0 RPM
Internal resistance of motor: 0,00 Ohm
Time for current reduction: 2000 ms
Time for overload switch-off: 200 ms

Transfer
Cancel

Fig. 27: Settings via KS2000

Operating mode (R33.0 - R33.3 [► 57])

Here you can select the basic operating mode for the channels (default: "velocity, direct").

The terminal supports the following operating modes:

- Velocity, direct
- Velocity control
- [Brake resistor \[► 18\]](#) (chopper)

General

Watchdog timer active (R32.2 [► 56])

Here you can deactivate the watchdog (default: active). If the DC motor output stage fails to receive process data from the controller for 100 ms when the watchdog is active, the watchdog is triggered, and the motor stops.

Automatic current reduction active (R32.10 [► 56])

Here you can activate automatic current reduction (default: inactive).

Automatic overload shutdown active (R32.9 [▶ 56])

Here you can activate automatic overload shutdown (default: inactive).

Velocity controller**Kp factor (R37 [▶ 58] only KL2552)**

Here you can specify the Kp factor (proportional part) for the internal velocity control (default: 0.1).

Ki factor (R38 [▶ 58] only KL2552)

Here you can specify the Ki factor (integral part) for the internal velocity control (default: 0).

Inner window for I-controller active (R33.4 [▶ 57], R39 [▶ 58] only KL2552)

Here you can activate the inner window for the I-controller (default: inactive) and the threshold from which the inner window is activated (default: 0 %).

External window for I-controller active (R33.5 [▶ 57], R40 [▶ 58] only KL2552)

Here you can activate the inner window for the I-controller (default: inactive) and the threshold up to which the inner window is activated (default: 0 %).

Ka factor (R54 [▶ 60] only KL2552)

Here you can specify the Kp factor (a-part) for the internal velocity control (default: 0).

Kd factor (R55 [▶ 60] only KL2552)

Here you can specify the Kd factor (differential part) for the internal velocity control (default: 0).

Encoder**Input filter active (R32.12 [▶ 56])**

Here you can deactivate the input filters for the encoder inputs disable (default: active).

increments per revolution (R42 [▶ 58] only KL2552)

Here you can specify the number of increments per revolution for the connected encoder (default: 0).

Motor data**Maximum coil current (R34 [▶ 58])**

Here you can specify the maximum motor coil current (default: 8000 mA).

Reduced coil current (positive direction of rotation) (R41 [▶ 58])

Here you can specify the reduced motor coil current (default: 5000 mA), see description of registers [R32.10 \[▶ 56\]](#), [R41 \[▶ 58\]](#) and [R45 \[▶ 59\]](#).

Threshold for current reduction (positive direction of rotation) (R45 [▶ 59])

Here you can specify the threshold from which automatic current reduction is enabled (default: 100 %).

Reduced coil current (negative direction of rotation) (R49 [▶ 59])

Here you can specify the reduced motor coil current (default: 5000 mA), see description of registers [R32.10 \[▶ 56\]](#), [R49 \[▶ 59\]](#) and [R48 \[▶ 59\]](#).

Threshold for current reduction (negative direction of rotation) (R48 [▶ 59])

Here you can specify the threshold from which automatic current reduction is enabled (default: 100 %).

Rated current (R35 [▶ 58])

Here you can specify the rated motor current (default: 5000 mA).

Rated voltage (R36 [▶ 58])

Here you can specify the rated motor voltage (default: 50 V).

Rated speed (R43 [▶ 59] only KL2552)

Here you can specify the rated motor speed (default: 0 rpm).

Internal motor resistance (R44 [▶ 59])

Here you can specify the internal motor resistance (default: 0 ohm).

Time constant for current reduction (R46 [▶ 59])

Here you can specify the time duration of the current reduction (default: 2000 ms).

Time for overload shutdown (R47 [▶ 59])

Here you can specify the time after which the output stage is switched off, if overload occurs over the whole interval (default: 200 ms).

5.5 Process data

The Status byte (Status), the Control byte (Ctrl) and the process data (Data) are displayed in a tree structure under *ProcData*.

Pos	Type	I-Address	Value	Bitsize	O-Address	Value	Bitsize
2	KL2552-0000						
	Channel 1						
	Status	0.0	0x00	8			
	Data In	2.0	0x0000	16			
	Ctrl				0.0	0x00	8
	Data Out				2.0	0x0000	16
	Channel 2						
	Status	4.0	0x00	8			
	Data In	6.0	0x0000	16			
	Ctrl				4.0	0x00	8
	Data Out				6.0	0x0000	16

Fig. 28: ProcData

The reading glasses mark the data that are currently graphically displayed in the *History* field.

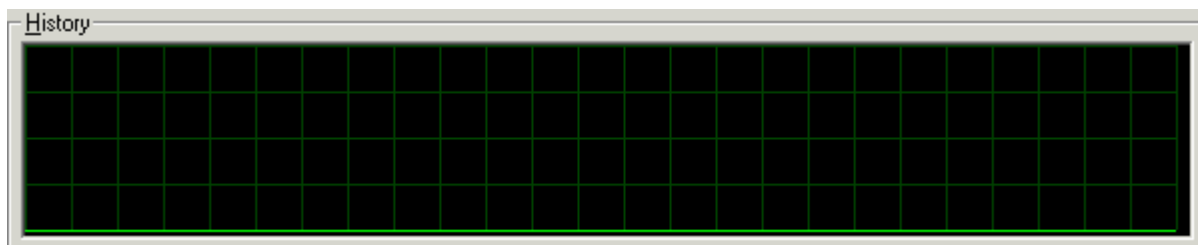

Fig. 29: History field

The current input values are displayed numerically in the *Value* field.

Fig. 30: Value field

Initial values can be modified through direct input or by means of the fader.

Fig. 31: Value field

⚠ CAUTION**Danger for persons, the environment or equipment!**

Note that changing initial values (forcing them) can have a direct effect on your automation application. Only modify these initial values if you are certain that the state of your equipment permits it, and that there will be no risk to people or to the machine!

After pressing the *Settings* button you can set the format of the numerical display to hexadecimal, decimal or binary.

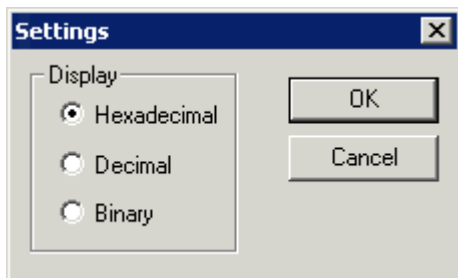

Fig. 32: Settings

6 Access from the user program

6.1 Process image

Complex process image

In the complex process image the KL2532/KL2552 is represented with at least 6 bytes of input data and 6 bytes of output data. These are organized as follows:

Byte offset (without word alignment)	Byte offset (with word alignment*)	Format	Input data	Output data
0	0	Byte	SB1 [▶ 48]	CB1 [▶ 47]
1	2	Word	DataIN1	DataOUT1
3	4	Byte	SB2 [▶ 49]	CB2 [▶ 49]
4	6	Word	DataIN2	DataOUT2

*) Word alignment: The Bus Coupler places values on even byte addresses

Legend

SB n: status byte channel n

CB n: Control byte of channel n

DataIN n: Input word of channel n

DataOUT n: Output word of channel n

i Complex process image

The KL2532/KL2552 cannot be operated without control bytes, since the control bytes are required for enabling the channels. Even if your Bus Coupler is set to compact process image, the KL2532/KL2552 is represented with its control bytes!

6.2 Control and status bytes

Channel 1

Process data mode

Control byte 1 (for process data mode)

Control byte 1 (CB1) is located in the [output image \[▶ 47\]](#), and is transmitted from the controller to the terminal.

Bit	CB1.7	CB1.6	CB1.5	CB1.4	CB1.3	CB1.2	CB1.1	CB1.0
Name	RegAccess	Reset	Enable	GetLatchData	enLatchFallEdge	enLatchRiseEdge	SetCounter	Reduced Torque

Legend

Bit	Name	Description	
CB1.7	RegAccess	0 _{bin}	Register communication off (process data mode)
CB1.6	Reset	1 _{bin}	all errors that may have occurred are reset by setting this bit (rising edge)
CB1.5	Enable	1 _{bin}	Enables channel 1
CB1.4	GetLatchData	0 _{bin}	Show the current position in the input process data
		1 _{bin}	Show the current latch value in the input process data
CB1.3	enLatch FallEdge	1 _{bin}	External latch event is enabled (for latch inputs with falling edge, the terminal saves the current position)
CB1.2	enLatch RiseEdge	1 _{bin}	External latch event is enabled (for latch inputs with rising edge, the terminal saves the current position) ATTENTION: higher priority than CB1.3!
CB1.1	SetCounter	1 _{bin}	The counter is set to the value specified by register R5 [► 54] if a rising edge occurs at CB1.1.
CB1.0	Reduced Torque	1 _{bin}	Reduced torque (coil current) is active (specified via R41 [► 58])

Status byte 1 (for process data mode)

The status byte 1 (SB1) is located in the input image, and is transmitted from terminal to the controller.

Bit	SB1.7	SB1.6	SB1.5	SB1.4	SB1.3	SB1.2	SB1.1	SB1.0
Name	RegAccess	Error	Warning	Ready	LatchData	LatchValid	SetCounter Ready/ Reduced Torque Ready	Input E1

Legend

Bit	Name	Description	
SB1.7	RegAccess	0 _{bin}	Acknowledgement for process data mode
SB1.6	Error	1 _{bin}	An error has occurred (is explicitly indicated in the status word in register R0 [► 53])
SB1.5	Warning	1 _{bin}	A warning has occurred (explicitly indicated in the status word in register R0 [► 53])
SB1.4	Ready	0 _{bin}	Motor control is disabled or an error has occurred (SB.6=1)
		1 _{bin}	Motor control is enabled and no error has occurred (acknowledgement for enable, SB.6=0)
SB1.3	LatchData	0 _{bin}	The current position is mapped into the input process data
		1 _{bin}	The most recent latch value is mapped into the input process data, provided a valid latch value exists (acknowledgement for GetLatchData)
SB1.2	LatchValid	1 _{bin}	A latch event has occurred (when CB1.2=1 or CB1.3=1)
SB1.1	SetCounter Ready/ Reduced Torque Ready	1 _{bin}	- the counter was set (acknowledgement for SetCounter) or - the reduced torque is active (acknowledgement for Reduced Torque)
SB1.0	Input E1	Status of input E1	

Register communication**Control byte 1 (in register communication)**

Control byte 1 (CB1) is located in the output image, and is transmitted from the controller to the terminal.

Bit	CB1.7	CB1.6	CB1.5	CB1.4	CB1.3	CB1.2	CB1.1	CB1.0
Name	RegAccess	R/W	Reg-Nr.					

Legend

Bit	Name	Description	
CB1.7	RegAccess	1 _{bin}	Register communication switched on
CB1.6	R/W	0 _{bin}	Read access
		1 _{bin}	Write access
CB1.5 to CB1.0	Reg. no.	Register number: Enter here the number of the <u>register</u> [▶ 50] that you wish - to read with input data word <u>DataIn</u> [▶ 47], or - to write with output data word <u>DataOut</u> [▶ 47].	

Status byte 1 (in register communication)

The status byte 1 (SB1) is located in the input image [▶ 47], and is transmitted from terminal to the controller.

Bit	SB1.7	SB1.6	SB1.5	SB1.4	SB1.3	SB1.2	SB1.1	SB1.0
Name	RegAccess	R/W	Reg-Nr.					

Legend

Bit	Name	Description	
SB1.7	RegAccess	1 _{bin}	Acknowledgement for register access
SB1.6	R	0 _{bin}	Read access
SB1.5 to SB1.0	Reg. no.	Number of the register that was read or written.	

Channel 2

The control and status bytes of channel 2 (CB2 and SB2) have the same structure as the control and status bytes of channel 1.

6.3 Register overview

The registers are used to parameterize the DC motor output stages. They can be read or written via the register communication and there is one instance for each terminal channel.

Register no.	Comment		Default value		R/W	Memory
R0 [▶ 53]	Status word		0x0000	0 _{dez}	R	RAM
R1 [▶ 53]	Selection for measured value 1 (low byte) and measured value 2 (high byte)	Channel 1	0x0602	1538 _{dec}	R/W	RAM
		Channel 2	0x0703	1795 _{dez}	R/W	RAM
R2 [▶ 54]	Measured value 1		e.g. 0x0000	e.g. 0 _{dec}	R	RAM
R3 [▶ 54]	Measured value 2		e.g. 0x0000	e.g. 0 _{dec}	R	RAM
R4 [▶ 54]*	Register page selection		0x0000	0 _{dec}	R/W	RAM
R5 [▶ 54]	Counter specification register		0x0000	0 _{dec}	R/W	RAM
R6 [▶ 54]	Status byte		e.g. 0x0010	e.g. 16 _{dec}	R	RAM
R7 [▶ 54]	Command register		0x0000	0 _{dec}	R/W	RAM
R8 [▶ 55]	Terminal type	KL2532/KS2532	0x09E4	2532 _{dec}	R	ROM
		KL2552/KS2552	0x09F8	2552 _{dec}		
R9 [▶ 56]	Firmware version		e.g. 0x3141	e.g. 1A _{ASCII}	R	ROM
R10	Multiplex shift register		0x0130	304 _{dec}	R	ROM
R11	Signal channels		0x0218	536 _{dec}	R	ROM
R12	Minimum data length		0x1818	6168 _{dec}	R	ROM
R13	Data structure		0x0004	4 _{dec}	R	ROM
R14	reserved		-	-	-	-
R15	Alignment register		e.g. 0x7F80	e.g. 32640 _{dec}	R/W	RAM
R16 [▶ 56]	Hardware version number		e.g. 0x0000	e.g. 0 _{dec}	R/W	EEPROM
R17 [▶ 56]	DC link frequency		e.g. 0x7D00	e.g. 32000 _{dec}	R	EEPROM
R18 [▶ 56]	PWM dead time	KL2532/KS2532	e.g. 0x0102	e.g. 258 _{dec}	R	EEPROM
		KL2552/KS2552	e.g. 0x0604	e.g. 1540	R	EEPROM
R19 [▶ 56]	Duty cycle limit		e.g. 0x0004	e.g. 4 _{dec}	R	EEPROM
R20 [▶ 56]	Temperature thresholds		e.g. 0x5064	e.g. 20580 _{dec}	R	EEPROM
R21 [▶ 56]	Sample time of the A/D converter		e.g. 0x000A	e.g. 10 _{dec}	R	EEPROM
R22	reserved		-	-	-	-
...
R30	reserved		-	-	-	-
R31 [▶ 56]	Code word register		0x0000	0 _{dec}	R/W	RAM

*) Only the KL2552 supports these registers, not the KL2532

Register page 0

Register no.	Comment		Default value		R/W	Memory
R32 [▶ 56]	Feature register 1		0x0000	0 _{dec}	R/W	EEPROM
R33 [▶ 57]	Feature register 2		0x0000	0 _{dec}	R/W	EEPROM
R34 [▶ 58]	Maximum permanent motor coil current	KL2532/KS2532	0x09C4	2500 _{dec}	R/W	EEPROM
		KL2552/KS2552	0x1F40	8000 _{dec}	R/W	EEPROM
R35 [▶ 58]	Rated current of the motor	KL2532/KS2532	0x05DC	1500 _{dec}	R/W	EEPROM
		KL2552/KS2552	0x1388	5000 _{dec}	R/W	EEPROM
R36 [▶ 58]	Nominal voltage (supply voltage) of the motor	KL2532/KS2532	0x5DC0	24000 _{dec}	R/W	EEPROM
		KL2552/KS2552	0xC350	50000 _{dec}	R/W	EEPROM
R37 [▶ 58]*	Kp factor (velocity controller)		0x0064	100 _{dec}	R/W	EEPROM
R38 [▶ 58]*	Ki factor (velocity controller)		0x0000	0 _{dec}	R/W	EEPROM
R39 [▶ 58]*	Inner window of the I component (velocity controller)		0x0000	0 _{dec}	R/W	EEPROM
R40 [▶ 58]*	Outer window of the I component (velocity controller)		0x0000	0 _{dec}	R/W	EEPROM
R41 [▶ 58]	Reduced torque (coil current in positive direction of rotation)	KL2532/KS2532	0x05DC	1500 _{dec}	R/W	EEPROM
		KL2552/KS2552	0x09C4	2500 _{dec}	R/W	EEPROM
R42 [▶ 58]*	Encoder increments		0x0000	0 _{dec}	R/W	EEPROM
R43 [▶ 59]*	Rated motor speed at rated voltage		0x0000	0 _{dec}	R/W	EEPROM
R44 [▶ 59]	Internal resistance of the motor		0x0000	0 _{dec}	R/W	EEPROM
R45 [▶ 59]	Threshold for automatic torque reduction (in positive direction of rotation)		0x0064	100 _{dec}	R/W	EEPROM
R46 [▶ 59]	Time for current reduction on overload		0x07D0	2000 _{dec}	R/W	EEPROM
R47 [▶ 59]	Time for shutdown on overload		0x00C8	200 _{dec}	R/W	EEPROM
R48 [▶ 59]	Threshold for automatic torque reduction (in negative direction of rotation)		0x0064	100 _{dec}	R/W	EEPROM
R49 [▶ 59]	Reduced torque (coil current in negative direction of rotation)	KL2532/KS2532	0x05DC	1500 _{dec}	R/W	EEPROM
		KL2552/KS2552	0x09C4	2500 _{dec}	R/W	EEPROM
R50 [▶ 59]*	Kp factor (current controller)		0x0190	400 _{dec}	R/W	EEPROM
R51 [▶ 60]*	Ki factor (current controller)		0x0004	4 _{dec}	R/W	EEPROM
R52 [▶ 60]	Inner window of the I component (current controller)		0x0000	0 _{dec}	R/W	EEPROM
R53 [▶ 60]	Outer window of the I component (current controller)		0x0000	0 _{dec}	R/W	EEPROM
R54 [▶ 60]*	Ka factor (velocity controller)		0x0000	0 _{dec}	R/W	EEPROM
R55 [▶ 60]*	Kd factor (velocity controller)		0x0000	0 _{dec}	R/W	EEPROM
R56	reserved		-	-	-	-
R63	reserved		-	-	-	-

*) Only the KL2552 supports these registers, not the KL2532

Register page 1 (only KL2552, from firmware version 1M)

(see also selection for measured value 1 and measured value 2 [► 53])

Register no.	Comment	Default value		R/W	Memory
R32	Status word channel 1	0x0000	0 _{dec}	R	RAM
R33	Status word channel 2	0x0000	0 _{dec}	R	RAM
R34	Voltage of motor coil channel 1 (unit: 1 mV)	0x0000	0 _{dec}	R	RAM
R35	Voltage of motor coil channel 2 (unit: 1 mV)	0x0000	0 _{dec}	R	RAM
R36	Motor supply voltage (unit: 1 mV)	0x0000	0 _{dec}	R	RAM
R37	Control voltage (power contacts)(unit: 1 mV)	0x0000	0 _{dec}	R	RAM
R38	Current of motor coil channel 1 (unit: 1 mA)	0x0000	0 _{dec}	R	RAM
R39	Current of motor coil channel 2 (unit: 1 mA)	0x0000	0 _{dec}	R	RAM
R40	Internal temperature of the driver stage (unit: 1 °C)	0x0000	0 _{dec}	R	RAM
R41	Duty cycle channel 1 (unit: 1 %)	0x0000	0 _{dec}	R	RAM
R42	Duty cycle channel 2 (unit: 1 %)	0x0000	0 _{dec}	R	RAM
R43	Control error channel 1 (unit: 1 digit)	0x0000	0 _{dec}	R	RAM
R44	Control error channel 2 (unit: 1 digit)	0x0000	0 _{dec}	R	RAM
R45	Current limit channel 1 (unit: 1 mA)	0x0000	0 _{dec}	R	RAM
R46	Current limit channel 2 (unit: 1 mA)	0x0000	0 _{dec}	R	RAM
R47	Current of motor coil channel 1 (amount), (unit: 1 mA)	0x0000	0 _{dec}	R	RAM
R48	Current of motor coil channel 2 (amount), (unit: 1 mA)	0x0000	0 _{dec}	R	RAM
R49	Current of motor coil channel 1 (mean amount), (unit: 1 mA)	0x0000	0 _{dec}	R	RAM
R50	Current of motor coil channel 2 (mean amount), (unit: 1 mA)	0x0000	0 _{dec}	R	RAM
R51	Current offset of motor coil channel 1 (synchronization), (unit: 1 digit)	0x0000	0 _{dec}	R	RAM
R52	Current offset of motor coil channel 2 (synchronization), (unit: 1 digit)	0x0000	0 _{dec}	R	RAM
R53	Duration of overload channel 1 (unit: 1 ms)	0x0000	0 _{dec}	R	RAM
R54	Duration of overload channel 2 (unit: 1 ms)	0x0000	0 _{dec}	R	RAM
R55	Reserved	-	-	-	-
R62	reserved	-	-	-	-
R63	Firmware version of the driver card	-	-	-	ROM

6.4 Register description

The registers are used to parameterize the DC motor output stages. They can be read or written via the register communication and there is one instance for each terminal channel.

R0: Status word

The status word contains information about internal states, warnings and errors (see "Basic function principles" [▶ 17] and "Status-Byte" [▶ 48])

Bit	R0.15	R0.14	R0.13	R0.12	R0.11	R0.10	R0.9	R0.8
Name	Misc Error	No Control Power	-	Short Circuit	Over Voltage	Under Voltage	Over Current	Over Temperature

Bit	R0.7	R0.6	R0.5	R0.4	R0.3	R0.2	R0.1	R0.0
Name	-	Saturated	Moving Negative	Moving Positive	Ready	Ready to Enable	-	-

Legend

Bit	Name	Reaction	Description
R0.15	Misc Error	Error	1 _{bin} Fault occurred
R0.14	No Control Power	Error	1 _{bin} Control voltage at the power contacts is less than 12 V
R0.13	-		reserved
R0.12	Short Circuit	Error	1 _{bin} Short circuit in the driver stage
R0.11	Over Voltage	Warning	1 _{bin} Supply voltage 10 % higher than specified in R36 [▶ 58]
R0.10	Under Voltage	Warning	1 _{bin} <ul style="list-style-type: none"> Supply voltage 80 % lower than specified in register R36 (warning) Supply voltage less than 8 V (error; in addition, registers R0.15 and bit SB1.6 [▶ 48] of the status register are set, and both channels are disabled)
R0.9	Over Current	Warning	1 _{bin} The actual current was higher than the rated current over the time specified in register R47 [▶ 59] .
R0.8	Over Temperature	Warning	1 _{bin} <ul style="list-style-type: none"> Internal terminal temperature is higher than 80 °C (warning) Internal terminal temperature is higher than 100 °C (error; in addition, registers R0.15 and bit SB1.6 [▶ 48] of the status register are set, and both channels are disabled)
R0.7	-		reserved
R0.6	Saturated	Warning	1 _{bin} Driver stage is in saturation (max. output value reached)
R0.5	Moving Negative		1 _{bin} Driver stage is activated in negative direction
R0.4	Moving Positive		1 _{bin} Driver stage is activated in positive direction
R0.3	Ready		1 _{bin} Driver stage is activated
R0.2	Ready to Enable		1 _{bin} Driver stage ready for activation
R0.0 - R0.1	-		reserved

R1: Selection for measured value 1 and measured value 2

Preselection of the measured values shown in [R2 \[▶ 54\]](#) and [R3 \[▶ 54\]](#). The lower byte is allocated to register 2, the upper byte to register 3.

Example: R1 = 0x0602, lower byte = 2 (voltage of motor coil channel 1), upper byte = 6 (current of motor coil channel 1).

Each individual value can be shown in channel 1 and channel 2.

The values are based on the following table:

Selection	Name	Unit
0	Internal status word channel 1	-
1	Internal status word channel 2	-
2	Voltage of motor coil channel 1	1 mV
3	Voltage of motor coil channel 2	
4	Motor supply voltage	
5	Control voltage (power contacts)	
6	Current of motor coil channel 1	1 mA
7	Current of motor coil channel 2	
8	Internal temperature of the driver stage	1°C
9	Duty cycle channel 1	1%
10	Duty cycle channel 2	
11	Control error channel 1	1 digit
12	Control error channel 2	
13	Current limit channel 1	1 mA
14	Current limit channel 2	
15	reserved	-
...	reserved	-
254	reserved	-
255	Firmware version of the driver card	-

R2: Measured value 1

Output of measured value 1 (see R1 [► 53]).

R3: Measured value 2

Output of measured value 2 (see R1 [► 53]).

R4: Register page selection (only KL2552, from firmware version 1M)

This register defines which register page is displayed in registers R32 to R63 (default: 0x0000).

The terminal supports two register pages.

- Register page 0 is used for saving the configuration data (see from register R32 [► 56])
- Register page 1 is used for reading internal measured values (additional mechanism for reading the measured values via registers R2 and R3)

R5: Counter specification register

Here you can specify the value to which the counter is set on rising edge at CB1.1 (SetCounter).

R6: Status byte

The status byte of the relevant channel is mapped here in addition.

R7: Command register

● User code word

i For the following commands to be executed, it is first necessary for the user code word, 0x1235, to be entered into register R31 [► 56].

Command 0x7000: Restore Factory Settings

KL2532

An entry of 0X7000 in register R7 sets the following registers for the two channels to the following default values:

R32: 0 _{dec}	R41 [▶ 58]:	R48 [▶ 59]: 100 _{dec}
R33 [▶ 57]: 0 _{dec}	1500 _{dec}	R49 [▶ 59]: 1500 _{dec}
R34 [▶ 58]:	R44 [▶ 59]: 0 _{dec}	R50 [▶ 59]: 400 _{dec}
2500 _{dec}	R45 [▶ 59]:	R51 [▶ 60]: 4 _{dec}
R35 [▶ 58]:	100 _{dcz}	R52 [▶ 60]: 0 _{dec}
1500 _{dec}	R46 [▶ 59]:	R53 [▶ 60]: 0 _{dec}
R36 [▶ 58]:	2000 _{dec}	
24000 _{dec}	R47 [▶ 59]:	
	200 _{dec}	

KL2552

An entry of 0X7000 in register R7 sets the following registers for the two channels to the following default values:

R32: 0 _{dec}	R40 [▶ 58]: 0 _{dec}	R48 [▶ 59]: 100 _{dec}
R33 [▶ 57]: 0 _{dec}	R41 [▶ 58]:	R49 [▶ 59]: 2500 _{dec}
R34 [▶ 58]:	2500 _{dec}	R50 [▶ 59]: 400 _{dec}
5000 _{dec}	R42 [▶ 58]: 0 _{dec}	R51 [▶ 60]: 4 _{dec}
R35 [▶ 58]:	R43 [▶ 59]: 0 _{dec}	R52 [▶ 60]: 0 _{dec}
1000 _{dec}	R44 [▶ 59]: 0 _{dec}	R53 [▶ 60]: 0 _{dec}
R36 [▶ 58]:	R45 [▶ 59]:	R54 [▶ 60]: 0 _{dec}
50000 _{dec}	100 _{dec}	R55 [▶ 60]: 0 _{dec}
R37 [▶ 58]:	R46 [▶ 59]:	
100 _{dec}	2000 _{dec}	
R38 [▶ 58]: 0 _{dec}	R47 [▶ 59]:	
R39 [▶ 58]: 0 _{dec}	200 _{dec}	

● Restore Factory Settings resets both channels

i The command Restore Factory Settings simultaneously resets both channels of the DC motor output stage terminal to the delivery state, irrespective of which register set it is called!

⚠ WARNING

Risk of injury!

This command is used to de-energies the motor. Ensure that your system state permits this and that hazards for persons or machinery have been ruled out!

Command 0x8000: Software Reset

Entering 0x8000 in register R7 initiates a full software reset for the terminal. All internal variables (positions, latched values, errors, etc.) are cleared or are set to defined values that are read from the EEPROM. The internal circuits (ADC, output driver) are reinitialized with a software reset.

⚠ WARNING

Risk of injury!

During a software reset the motor is switched current-free. Ensure that your system state permits this and that hazards for persons or machinery have been ruled out!

R8: Terminal type

The terminal identifier is contained in register R8: 0x09F8 (2552_{dec})

R9: Firmware version

Register R9 contains the ASCII coding of the terminal's firmware version, e.g. **0x3141** = '1A'. The '0x31' corresponds here to the ASCII character '1', while the '0x41' represents the ASCII character 'A'. This value cannot be changed.

R16: Hardware version number

Register R16 contains the hardware version of the terminal.

R17: DC link frequency

This is a manufacturer register and cannot be modified by the user.

The DC link frequency is configured here.

R18: PWM dead time

This is a manufacturer register and cannot be modified by the user.

The dead time of the high side and low side transistors is configured here.

R19: Duty cycle limit

This is a manufacturer register and cannot be modified by the user.

The minimum and maximum duty cycle in relation to the DC link frequency is configured here.

R20: Temperature thresholds

This is a manufacturer register and cannot be modified by the user.

The temperature thresholds for evaluating the internal temperature of the driver stage are configured here (warning output/shutdown of the driver stage).

R21: Sample time of the A/D converter

This is a manufacturer register and cannot be modified by the user.

The sample time in relation to the duty cycle is configured here.

R31: Code word register

If you write values into the user registers without first entering the user code word (0x1235) into the code word register, the terminal will not accept the supplied data. The code word is reset if the terminal is restarted.

Register page 0

Register page 0 is used for saving the configuration data.

R32: Feature register 1

The feature register 1 specifies the terminal's configuration.

Bit	R32.15	R32.14	R32.13	R32.12	R32.11	R32.10	R32.9	R32.8
Name	-	-	-	disEncoder filter	-	enAutoReduce	enOverCurrentErr or	-

Bit	R32.7	R32.6	R32.5	R32.4	R32.3	R32.2	R32.1	R32.0
Name	-	-	-	-	-	disWatchdog	-	-

Legend

Bit	Name	Description	default
R32.13 - R32.15	-	reserved	
R32.12	disEncoder filter	1 _{bin} Input filter for encoder signals deactivated	0 _{bin}
R32.11	-	reserved	
R32.10	enAutoReduce	0 _{bin} The torque can be reduced manually with bit CB1.0 [▶ 47] (see also R40 [▶ 58], R49)	0 _{bin}
		1 _{bin} The torque is reduced automatically (see also R41 [▶ 58], R45 [▶ 59] or R49, R48)	
R32.9	enOverCurrentError	0 _{bin} Overload (R0.9 = 1) generates a warning (SB1.5 [▶ 48])	0 _{bin}
		1 _{bin} Overload (R0.9 = 1) generates an error (SB1.6 [▶ 48]), and the channel is disabled	
R32.3 - R32.8	-	reserved	
R32.2	disWatchdog	1 _{bin} Internal 100 ms watchdog deactivated	0 _{bin}
R32.0 - R32.1	-	reserved	

R33: Feature register 2

The feature register 2 specifies the terminal's configuration.

Bit	R33.15	R33.14	R33.13	R33.12	R33.11	R33.10	R33.9	R33.8
Name	-	-	-	-	-	-	-	-

Bit	R33.7	R33.6	R33.5	R33.4	R33.3	R33.2	R33.1	R33.0
Name	-	-	enOuter Window	enInner Window	Operation Mode			

Legend

Bit	Name	Description	default
R33.6 - R33.15	-	reserved	
R33.5*	enOuter Window	1 _{bin} Outer window of the I component of the internal velocity control active	0 _{bin}
R33.4*	enInner Window	1 _{bin} Inner window of the I component of the internal velocity control active	0 _{bin}
R33.0 - R33.3	Operation Mode	0 _{dez} DIRECT MODE Direct duty cycle control proportional to the process data	0 _{dez}
		1 _{dez} VELOCITY MODE Set velocity specification via the process data proportional to the set rated speed in R43 [▶ 59]	
		3 _{dez} reserved	
		14 _{dez} reserved	
		15 _{dez} CHOPPER MODE Existing overvoltage (10% > rated voltage R36 [▶ 58]) is reduced via connected chopper resistor	

*) These settings are only supported by the KL2552, not by the KL2532

R34: Maximum permanent motor coil current

This register reflects the maximum constant motor coil current specified by the motor manufacturer.

KL2532/KS2532: Default: 2500_{dec}, range: 0 - 2500 mA

KL2552/KS2552: Default: 8000_{dec}, range: 0 - 8000 mA

The unit is 0.001 A (example: 2500_{dec} = 2.5 A).

R35: Rated current of the motor

This register reflects the rated motor current specified by the motor manufacturer.

KL2532/KS2532: Default: 1500_{dec}, range: 0 - 1500 mA

KL2552/KS2552: Default: 05000_{dec}, range: 0 - 5000 mA

The unit is 0.001 A (example: 1500_{dec} = 1.5 A).

R36: Nominal voltage (supply voltage) of the motor

If the supply voltage increases above the set voltage due to feedback, the respective channel (chopper resistor must be connected) is fully opened and the overvoltage reduced, provided the chopper function (see [R33 \[▶ 57\]](#)) is activated.

KL2532/KS2532: Default: 24000_{dec}, range: 0 V - 24 V

KL2552/KS2552: Default: 50000_{dec}, range: 0 V - 50 V

The unit is 0.001 V (for example: 24000_{dec} = 24 V).

R37: Kp factor (velocity controller, only KL2552)

This register contains the Kp factor for the proportional component of the internal velocity control (default: 100_{dec}).

The unit is 0.001 (example: 1000_{dec} => Kp = 1.00). Value range: 0 - 65535

R38: Ki factor (velocity controller, only KL2552)

This register contains the Ki factor for the integral component of the internal velocity control (default: 0_{dec}).

The unit is 0.001 (example: 1000_{dec} => Ki = 1.00). Value range: 0 - 65535

R39: Inner window of the I component (only KL2552)

The I component of the velocity control reduced linearly towards the zero point (default: 0_{dec}). This register specifies the value from which the attenuation is activated (default: 0_{dec}).

The unit is 1% (for example: 1 = 1%). Value range: 0% - 100 %

R40: Outer window of the I component (only KL2552)

This register specifies the maximum value of the I component (default: 0_{dec}).

The unit is 1% (for example: 5_{dec} = 5%). Value range: 0% - 100 %

R41: Reduced torque (coil current in positive direction of rotation)

This register contains the reduced torque (coil current) in positive direction of rotation. It is activated by CB1.0.

KL2532/KS2532: Default: 1500_{dec}, range: 0 mA - 1500 mA

KL2552/KS2552: Default: 2500_{dec}, range: 0 mA - 5000 mA

The unit is 0.001 A (for example: 500_{dec} = 0.5 A).

R42: Encoder increments (KL2552 only)

This register contains the number of encoder increments per motor revolution (default: 0_{dec}).

Value range: 0 - 65535

R43: Rated motor speed at rated voltage (only KL2552)

This register contains the rated motor speed at rated voltage (default: 0_{dec}).

The unit is 1 RPM. Value range: 0 - 65535 RPM

R44: Internal resistance of the motor

This register contains the internal resistance of the motor (default: 0_{dec}).

The unit is 0.01 Ohm (example: $206_{dec} = 2.06$ Ohm). Value range: 0 Ohm - 655,35 Ohm

R45: Threshold for automatic torque reduction (in positive direction of rotation)

This register contains the threshold at which automatic torque reduction is activated ([R41](#) [[▶](#)] [58](#)) (default: 0_{dec}). Deactivation occurs with a hysteresis of approx. 2% of the full scale (65 digit).

The unit is 1% (for example: $5_{dec} = 5\%$). Value range: 0% - 100%

R46: Time for current reduction on overload

This register contains the time over which the motor current is reduced from the maximum value to the rated value. This happens based on an I^2t function, i.e. the behavior is nonlinear. Depending on the actual motor current, it may take longer than the set time for the rated current to be reached (default: 2000_{dec}).

The unit is 1 ms (for example: $2000_{dec} = 2000$ ms). Value range: 1 ms - 65535 ms (if 0 ms is configured, the terminal uses the default value of 2000 ms)

R47: Time to shutdown on overload

This register contains the time after which the output stage is switched off, if overload occurs over the whole interval. (Default: 200_{dec}).

The unit is 1 ms (for example: $200_{dec} = 200$ ms). Value range: 0 ms - 65535 ms

R48: Threshold for automatic torque reduction (in negative direction of rotation)

This register contains the threshold (negative direction of rotation), from which the automatic torque reduction is enabled ([R49](#) [[▶](#)] [59](#)) (default: 100_{dec}). Deactivation occurs with a hysteresis of approx. 2% of the full scale (65 digit).

The unit is 1% (for example: $5_{dec} = 5\%$). Value range: 0% - 100%

R49: Reduced torque (coil current in negative direction of rotation)

This register contains the reduced torque (coil current) in negative direction of rotation. It is activated by CB1.0.

KL2532/KS2532: Default: 1500_{dec} , range: 0 mA - 1500 mA

KL2552/KS2552: Default: 2500_{dec} , range: 0 mA - 5000 mA

The unit is 0.001 A (for example: $500_{dec} = 0.5$ A).

R50: Kp factor (current controller, only KL2552)

This register contains the Kp factor for the proportional component of the internal current control (default: 400_{dec}).

The unit is 0.001 (example: $1000_{dec} \Rightarrow Kp = 1.00$). Value range: 0 - 65535

R51: Ki factor (current controller, only KL2552)

This register contains the Ki factor for the integral component of the internal current control (default: 4_{dec}).

The unit is 0.001 (example: 1000_{dec} => Ki = 1.00). Value range: 0 - 65535

R52: Inner window of the I component (current controller)

The I component of the velocity control reduced linearly towards the zero point (default: 0_{dec}). This register specifies the value from which the attenuation is activated (default: 0_{dec}).

The unit is 1% (for example: 1 = 1%). Value range: 0% - 100%

R53: Outer window of the I component (current controller)

This register specifies the maximum value of the I component (default: 0_{dec}).

The unit is 1% (for example: 5_{dec} = 5%). Value range: 0% - 100%

R54: Ka factor (velocity controller, only KL2552)

This register contains the Ka factor for the integral component of the internal velocity control (default: 0_{dec}).

The unit is 0.001 (example: 1000_{dec} => Ki = 1.00). Value range: 0 - 65535

R55: Kd factor (velocity controller, only KL2552)

This register contains the Kd factor of the differential component of the internal velocity control (default: 0_{dec}).

The unit is 0.1 (example: 10_{dec} => Kd = 1.00). Value range: 0 - 65535

Register page 1 (only KL2552, from firmware version 1M)

Register page 1 is used for reading internal measured values.

See register overview [► 52]

6.5 Examples of Register Communication

The numbering of the bytes in the examples corresponds to the display without word alignment.

6.5.1 Example 1: reading the firmware version from Register 9

Output Data

Byte 0: Control byte	Byte 1: DataOUT1, high byte	Byte 2: DataOUT1, low byte
0x89 (1000 1001 _{bin})	0xXX	0xXX

Explanation:

- Bit 0.7 set means: Register communication switched on.
- Bit 0.6 not set means: reading the register.
- Bits 0.5 to 0.0 specify the register number 9 with 00 1001_{bin}.
- The output data word (byte 1 and byte 2) has no meaning during read access. To change a register, write the required value into the output word.

Input Data (answer of the Bus Terminal)

Byte 0: Status byte	Byte 1: DataIN1, high byte	Byte 2: DataIN1, low byte
0x89	0x33	0x41

Explanation:

- The terminal returns the value of the control byte as a receipt in the status byte.
- The terminal returns the firmware version 0x3341 in the input data word (byte 1 and byte 2). This is to be interpreted as an ASCII code:
 - ASCII code 0x33 represents the digit 3
 - ASCII code 0x41 represents the letter A
 The firmware version is thus 3A.

6.5.2 Example 2: Writing to an user register

Code word

In normal mode all user registers are read-only with the exception of Register 31. In order to deactivate this write protection you must write the code word (0x1235) into Register 31. If a value other than 0x1235 is written into Register 31, write protection is reactivated. Please note that changes to a register only become effective after restarting the terminal (power-off/power-on).

I. Write the code word (0x1235) into Register 31.

Output Data

Byte 0: Control byte	Byte 1: DataOUT1, high byte	Byte 2: DataOUT1, low byte
0xDF (1101 1111 _{bin})	0x12	0x35

Explanation:

- Bit 0.7 set means: Register communication switched on.
- Bit 0.6 set means: writing to the register.
- Bits 0.5 to 0.0 specify the register number 31 with 01 1111_{bin}.
- The output data word (byte 1 and byte 2) contains the code word (0x1235) for deactivating write protection.

Input Data (answer of the Bus Terminal)

Byte 0: Status byte	Byte 1: DataIN1, high byte	Byte 2: DataIN1, low byte
0x9F (1001 1111 _{bin})	0xFF	0xFF

Explanation:

- The terminal returns a value as a receipt in the status byte that differs only in bit 0.6 from the value of the control byte.
- The input data word (byte 1 and byte 2) is of no importance after the write access. Any values still displayed are invalid!

II. Read Register 31 (check the set code word)

Output Data

Byte 0: Control byte	Byte 1: DataOUT1, high byte	Byte 2: DataOUT1, low byte
0x9F (1001 1111 _{bin})	0xFF	0xFF

Explanation:

- Bit 0.7 set means: Register communication switched on.
- Bit 0.6 not set means: reading the register.
- Bits 0.5 to 0.0 specify the register number 31 with 01 1111_{bin}.
- The output data word (byte 1 and byte 2) has no meaning during read access.

Input Data (answer of the Bus Terminal)

Byte 0: Status byte	Byte 1: DataIN1, high byte	Byte 2: DataIN1, low byte
0x9F (1001 1111 _{bin})	0x12	0x35

Explanation:

- The terminal returns the value of the control byte as a receipt in the status byte.
- The terminal returns the current value of the code word register in the input data word (byte 1 and byte 2).

III. Write to Register 32 (change contents of the feature register)

Output data

Byte 0: Control byte	Byte 1: DataIN1, high byte	Byte 2: DataIN1, low byte
0xE0 (1110 0000 _{bin})	0x00	0x02

Explanation:

- Bit 0.7 set means: Register communication switched on.
- Bit 0.6 set means: writing to the register.
- Bits 0.5 to 0.0 indicate register number 32 with 10 0000_{bin}.
- The output data word (byte 1 and byte 2) contains the new value for the feature register.

⚠ CAUTION

Observe the register description!

The value of 0x0002 given here is just an example!

The bits of the feature register change the properties of the terminal and have a different meaning, depending on the type of terminal. Refer to the description of the feature register of your terminal (chapter *Register description*) regarding the meaning of the individual bits before changing the values.

Input data (response from the Bus Terminal)

Byte 0: Status byte	Byte 1: DataIN1, high byte	Byte 2: DataIN1, low byte
0xA0 (1010 0000 _{bin})	0xFF	0xFF

Explanation:

- The terminal returns a value as a receipt in the status byte that differs only in bit 0.6 from the value of the control byte.
- The input data word (byte 1 and byte 2) is of no importance after the write access. Any values still displayed are invalid!

IV. Read Register 32 (check changed feature register)

Output Data

Byte 0: Control byte	Byte 1: DataOUT1, high byte	Byte 2: DataOUT1, low byte
0xA0 (1010 0000 _{bin})	0xFF	0xFF

Explanation:

- Bit 0.7 set means: Register communication switched on.
- Bit 0.6 not set means: reading the register.
- Bits 0.5 to 0.0 indicate register number 32 with 10 0000_{bin}.
- The output data word (byte 1 and byte 2) has no meaning during read access.

Input Data (answer of the Bus Terminal)

Byte 0: Status byte	Byte 1: DataIN1, high byte	Byte 2: DataIN1, low byte
0xA0 (1010 0000 _{bin})	0x00	0x02

Explanation:

- The terminal returns the value of the control byte as a receipt in the status byte.
- The terminal returns the current value of the feature register in the input data word (byte 1 and byte 2).

V. Write Register 31 (reset code word)

Output Data

Byte 0: Control byte	Byte 1: DataOUT1, high byte	Byte 2: DataOUT1, low byte
0xDF (1101 1111 _{bin})	0x00	0x00

Explanation:

- Bit 0.7 set means: Register communication switched on.
- Bit 0.6 set means: writing to the register.
- Bits 0.5 to 0.0 specify the register number 31 with 01 1111_{bin}.
- The output data word (byte 1 and byte 2) contains 0x0000 for reactivating write protection.

Input Data (answer of the Bus Terminal)

Byte 0: Status byte	Byte 1: DataIN1, high byte	Byte 2: DataIN1, low byte
0x9F (1001 1111 _{bin})	0xFF	0xFF

Explanation:

- The terminal returns a value as a receipt in the status byte that differs only in bit 0.6 from the value of the control byte.
- The input data word (byte 1 and byte 2) is of no importance after the write access. Any values still displayed are invalid!

7 Appendix

7.1 Support and Service

Beckhoff and their partners around the world offer comprehensive support and service, making available fast and competent assistance with all questions related to Beckhoff products and system solutions.

Beckhoff's branch offices and representatives

Please contact your Beckhoff branch office or representative for local support and service on Beckhoff products!

The addresses of Beckhoff's branch offices and representatives round the world can be found on her internet pages: <https://www.beckhoff.com>

You will also find further documentation for Beckhoff components there.

Beckhoff Support

Support offers you comprehensive technical assistance, helping you not only with the application of individual Beckhoff products, but also with other, wide-ranging services:

- support
- design, programming and commissioning of complex automation systems
- and extensive training program for Beckhoff system components

Hotline: +49 5246 963 157
Fax: +49 5246 963 9157
e-mail: support@beckhoff.com

Beckhoff Service

The Beckhoff Service Center supports you in all matters of after-sales service:

- on-site service
- repair service
- spare parts service
- hotline service

Hotline: +49 5246 963 460
Fax: +49 5246 963 479
e-mail: service@beckhoff.com

Beckhoff Headquarters

Beckhoff Automation GmbH & Co. KG

Huelshorstweg 20
33415 Verl
Germany

Phone: +49 5246 963 0
Fax: +49 5246 963 198
e-mail: info@beckhoff.com
web: <https://www.beckhoff.com>

List of illustrations

Fig. 1	BIC as data matrix code (DMC, code scheme ECC200).....	9
Fig. 2	KL2532	11
Fig. 3	KL2552	12
Fig. 4	KL2532 - LEDs	14
Fig. 5	KL2552 - LEDs	15
Fig. 6	Current through the brake resistor.....	18
Fig. 7	Spring contacts of the Beckhoff I/O components.....	20
Fig. 8	Attaching on mounting rail	21
Fig. 9	Disassembling of terminal.....	22
Fig. 10	Power contact on left side.....	23
Fig. 11	Recommended distances of installation position for operating without fan	25
Fig. 12	Recommended distances for installation position for operation with fan	26
Fig. 13	Other installation positions, example 1	26
Fig. 14	Other installation positions, example 2	27
Fig. 15	Standard wiring.....	27
Fig. 16	Pluggable wiring	28
Fig. 17	High Density Terminals.....	28
Fig. 18	Connecting a cable on a terminal point	29
Fig. 19	KL2532/KS2532 pin assignment	32
Fig. 20	KL2552/KS2552 pin assignment	33
Fig. 21	KL2552-0005/KS2552-0005 pin assignment.....	35
Fig. 22	KL2552 application example.....	37
Fig. 23	KS2000 configuration software.....	38
Fig. 24	Display of the fieldbus station in KS2000	40
Fig. 25	KS2000 tree branches for channel 1 of the KL2552.....	40
Fig. 26	Register view in KS2000.....	41
Fig. 27	Settings via KS2000	42
Fig. 28	ProcData.....	45
Fig. 29	History field	45
Fig. 30	Value field.....	45
Fig. 31	Value field.....	45
Fig. 32	Settings.....	46