

Montageanleitung B23, für AMP8620-2005-0xxx

konfektionierbares Steckergehäuse mit Crimpanschluss, axial,

5x4 mm², PWR: Powerbuchse



Stückliste

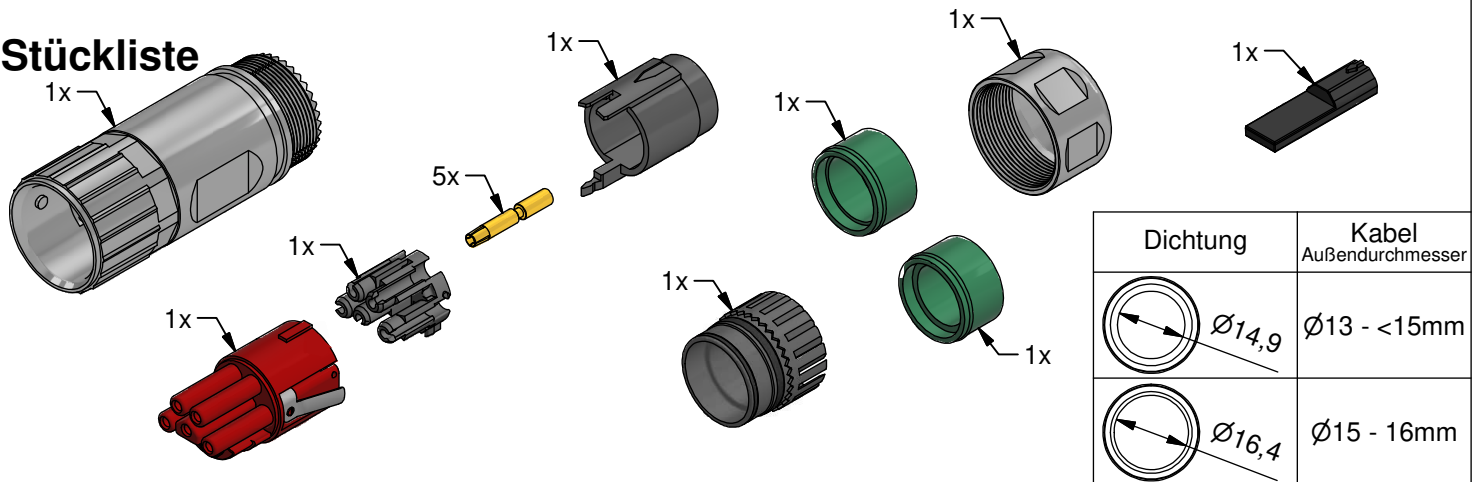

Dichtung	Kabel Außendurchmesser
	Ø13 - <15mm
	Ø15 - 16mm

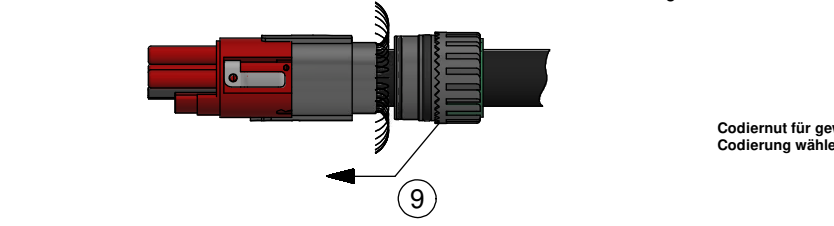
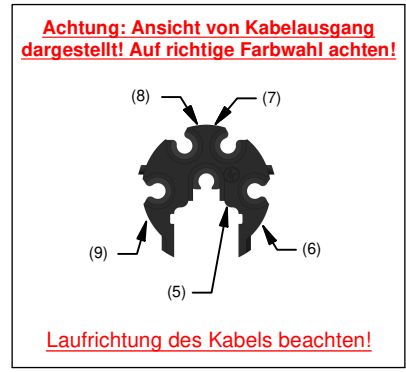
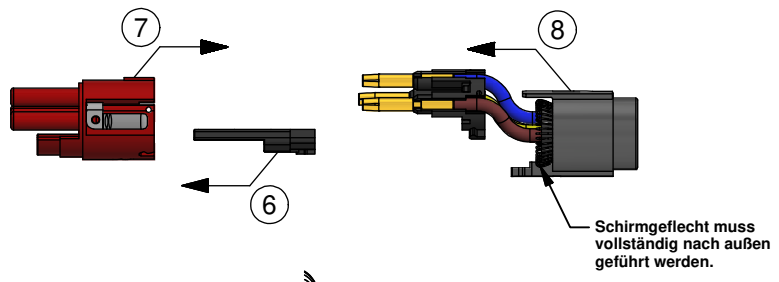
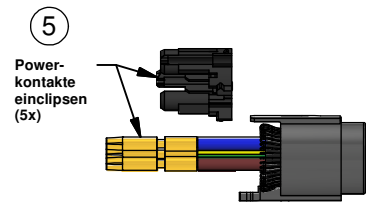
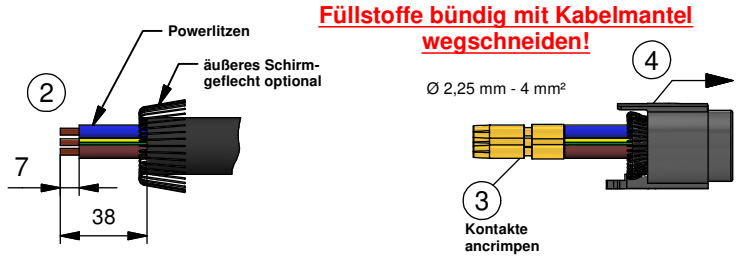
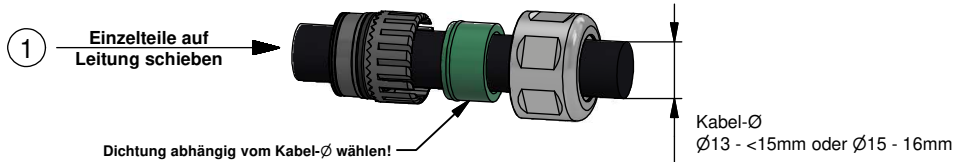

Farbring optional
ZS7300-B005 (rot)
ZS7300-B006 (gelb)
ZS7300-B007 (blau)
ZS7300-B008 (grün)

Schirmgeflecht muss gekürzt werden und darf nicht über O-Ring ragen!

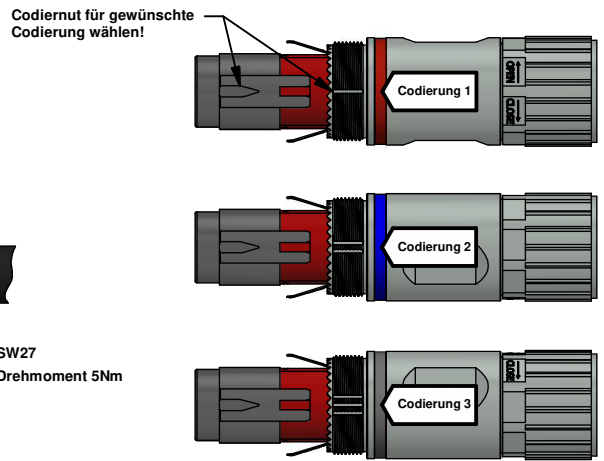

Beckhoff®, TwinCAT®, EtherCAT®, EtherCAT P®, Safety over EtherCAT®, TwinSAFE®, XFC® und XTS® sind eingetragene und lizenzierte Marken der Beckhoff Automation GmbH. Die Verwendung anderer in dieser Dokumentation enthaltenen Marken oder Kennzeichen durch Dritte kann zu einer Verletzung von Rechten der Inhaber der entsprechenden Kennzeichen führen.

Die Informationen in dieser Druckschrift enthalten lediglich allgemeine Beschreibungen bzw. Leistungsmerkmale, welche im konkreten Anwendungsfall nicht immer in der beschriebenen Form zutreffen bzw. welche sich durch Weiterentwicklung der Produkte ändern können. Die gewünschten Leistungsmerkmale sind nur dann verbindlich, wenn sie bei Vertragsabschluss ausdrücklich vereinbart werden.

Werkzeug / Zubehör	
Crimpzange	Crimpeinsatz / Locator
ZB8810-0000	ZB8810-0002

Assembly instruction B23, for AMP8620-2005-0xxx

field attachable plug housing with crimp connection, axial,
5x4 mm², PWR: power (female)

parts list

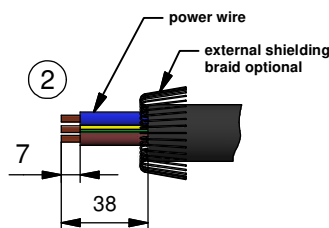
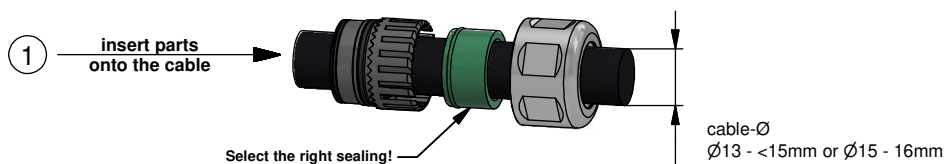
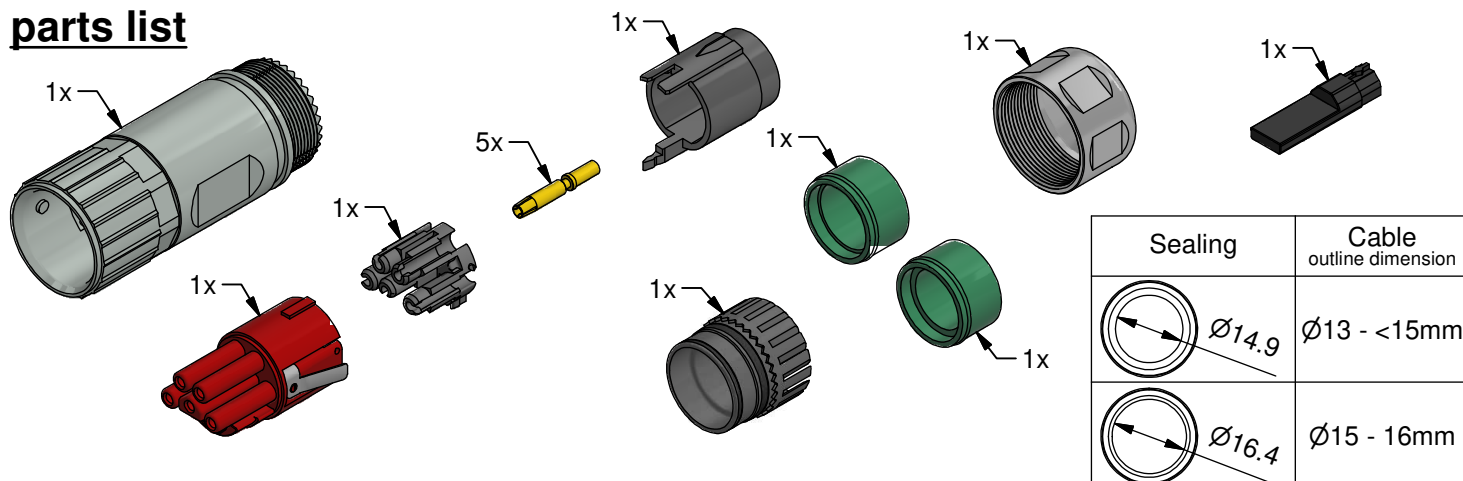

Cut off the fillers!

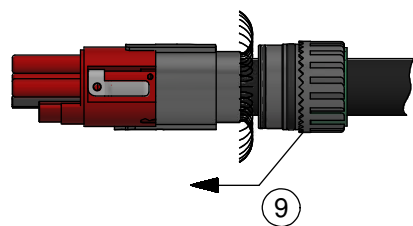
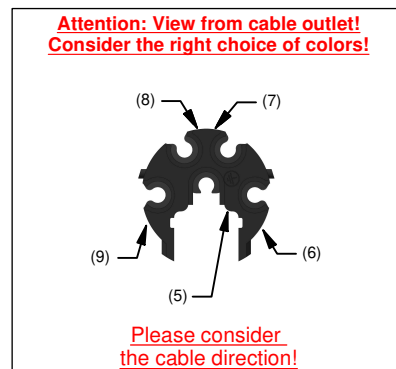
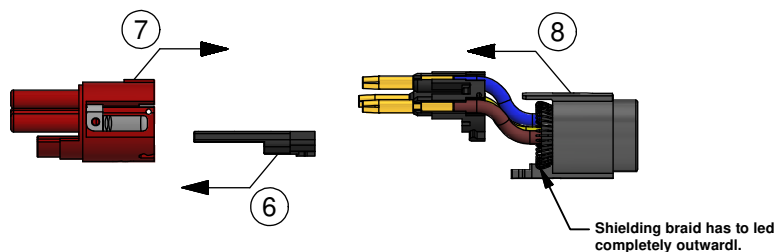
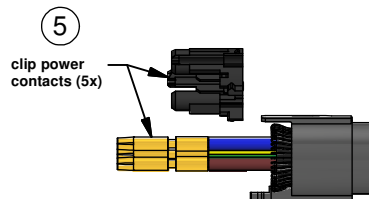
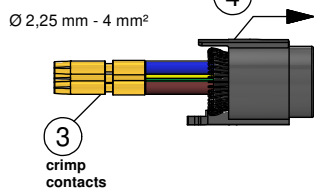

color ring optional
ZS7300-B005 (red)
ZS7300-B006 (yellow)
ZS7300-B007 (blue)
ZS7300-B008 (green)

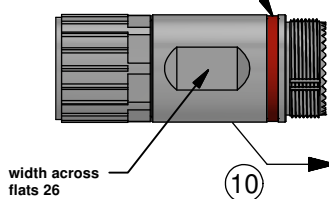

Shielding braid has to be shortened. It isn't allowed to protrude above the o-ring.

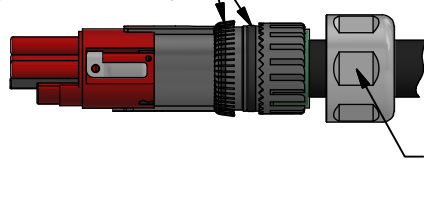

Select the right coding!

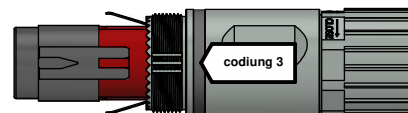
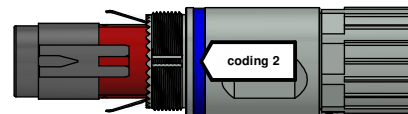
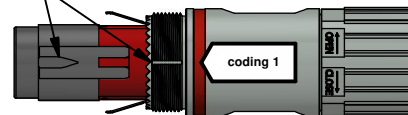

Beckhoff®, TwinCAT®, EtherCAT®, EtherCAT P®, Safety over EtherCAT®, TwinSAFE®, XFC® and XTS® are registered trademarks of and licensed by Beckhoff Automation GmbH. Other designations used in this publication may be trademarks whose use by third parties for their own purposes could violate the rights of the owners.

© Beckhoff Automation GmbH & Co. KG 10/2024

Beckhoff Art.-Nr.: ZS7300 - 0027

The information provided in this brochure contains merely general descriptions or characteristics of performance which in case of actual application do not always apply as described or which may change as a result of further development of the products. An obligation to provide the respective characteristics shall only exist if expressly agreed in the terms of contract.

BECKHOFF

tools / accessory parts	
crimping tool	crimping insert / locator
ZB8810-0000	ZB8810-0002