

Montageanleitung B23

konfektionierbares Steckergehäuse mit Crimpanschluss, axial,
5x2,5 mm², PWR: Powerbuchse

Stückliste

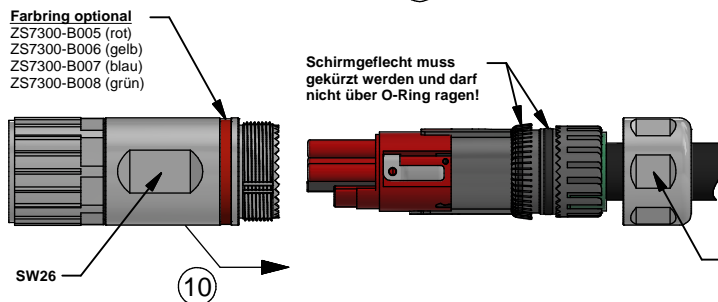
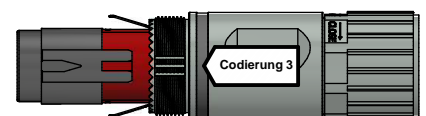
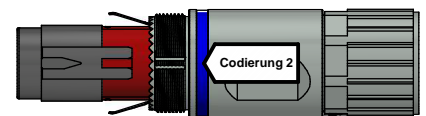
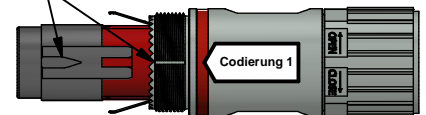
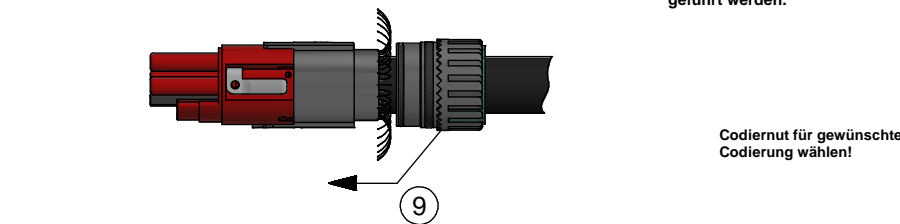
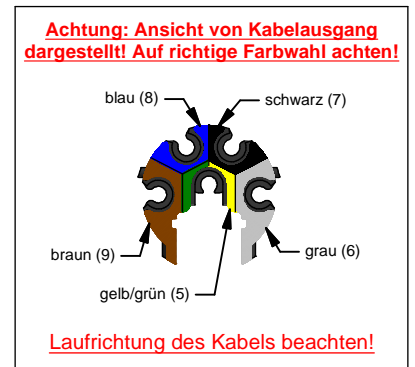
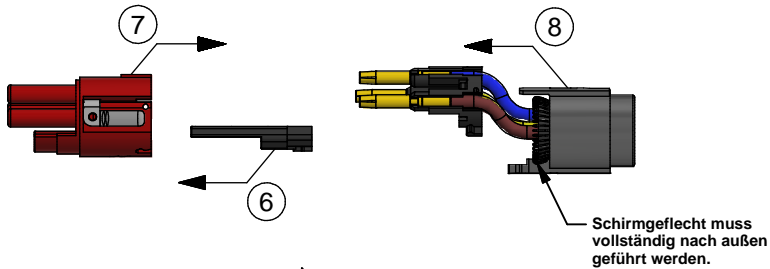
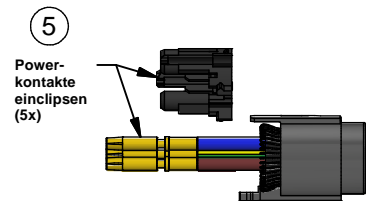
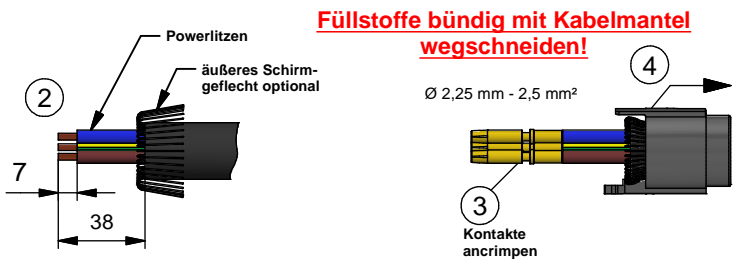
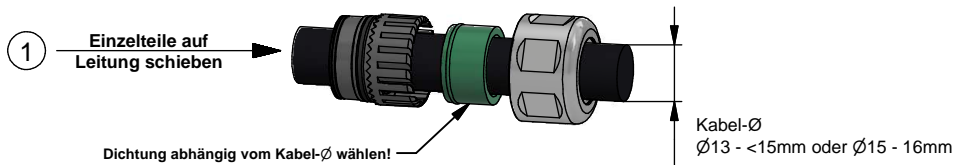
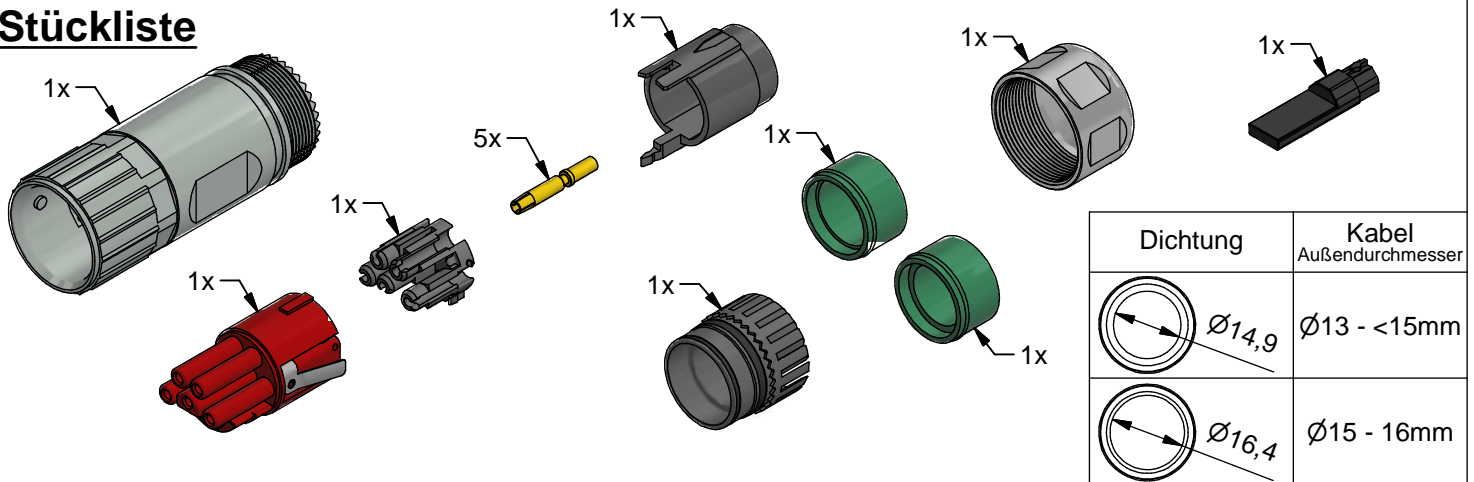

Beckhoff®, TwinCAT®, EtherCAT®, EtherCAT P®, Safety over EtherCAT®, TwinSAFE®, XFC® und XTS® sind eingetragene und lizenzierte Marken der Beckhoff Automation GmbH. Die Verwendung anderer in dieser Dokumentation enthaltenen Marken oder Kennzeichen durch Dritte kann zu einer Verletzung von Rechten der Inhaber der entsprechenden Kennzeichen führen.

Die Informationen in dieser Druckschrift enthalten lediglich allgemeine Beschreibungen bzw. Leistungsmerkmale, welche im konkreten Anwendungsfall nicht immer in der beschriebenen Form zutreffen bzw. welche sich durch Weiterentwicklung der Produkte ändern können. Die gewünschten Leistungsmerkmale sind nur dann verbindlich, wenn sie bei Vertragsabschluss ausdrücklich vereinbart werden.

Werkzeug / Zubehör	
Crimpzange	Crimpeinsatz / Locator
ZB8810-0000	ZB8810-0002

Assembly instruction B23

field attachable plug housing with crimp connection, axial,

5x2.5 mm², PWR: power (female)

parts list

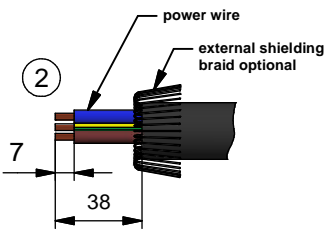
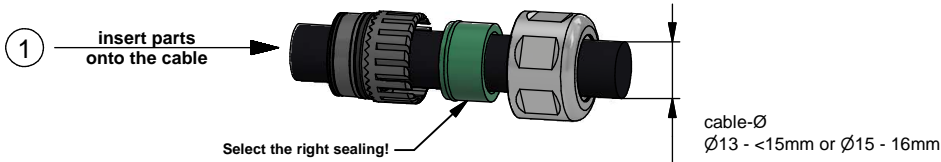
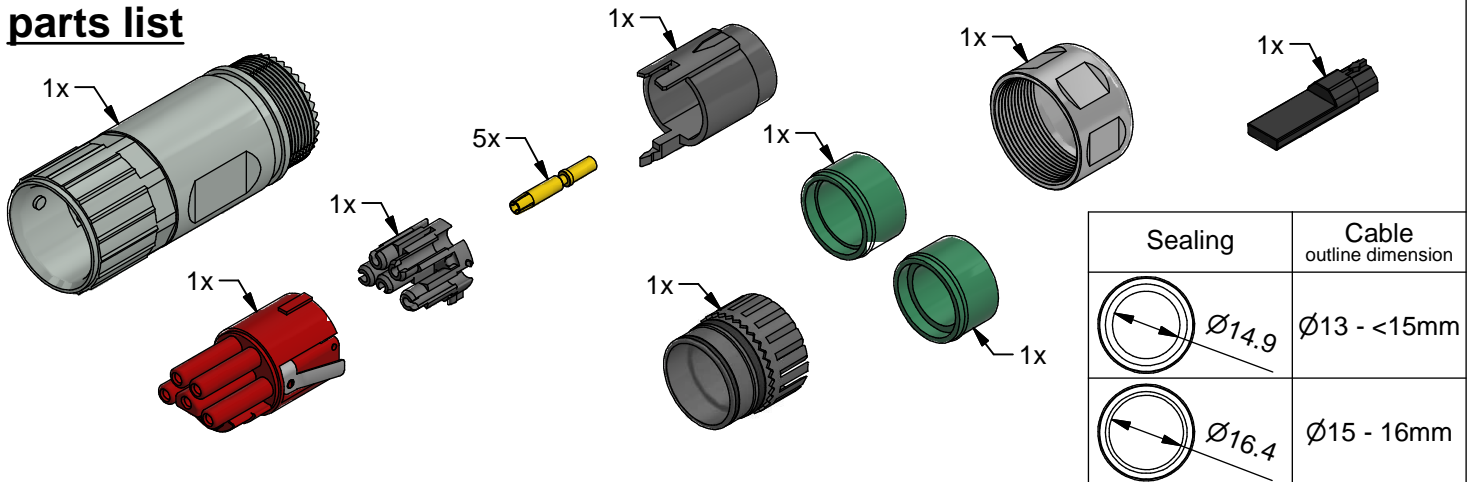

Cut off the fillers!

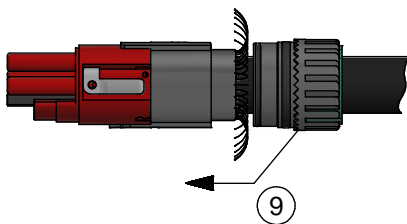
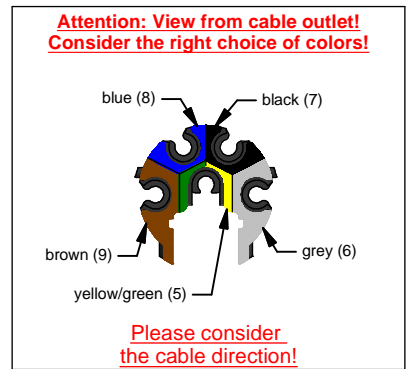
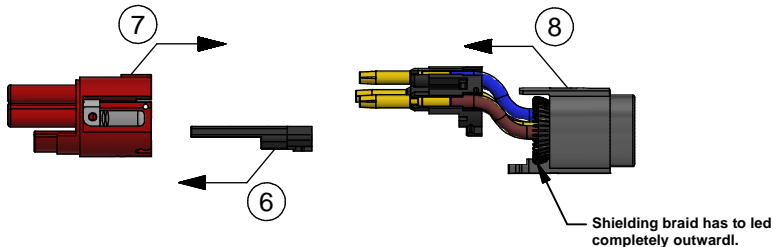
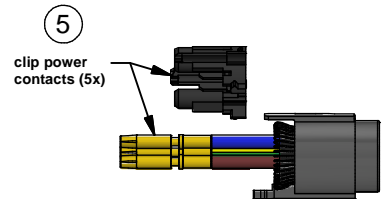
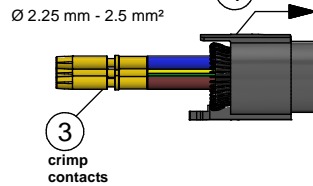

Select the right coding!

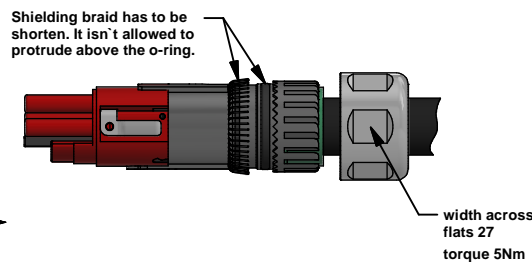
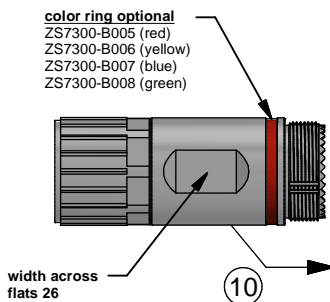
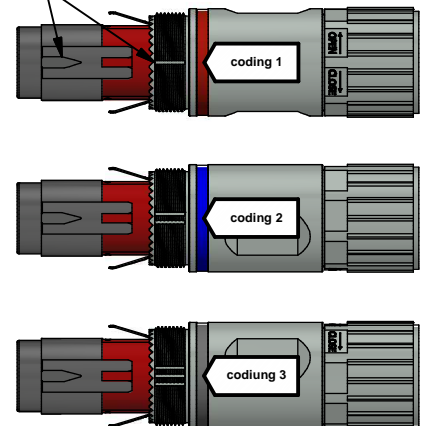

Beckhoff®, TwinCAT®, EtherCAT®, EtherCAT P®, Safety over EtherCAT®, TwinSAFE®, XFC® and XTS® are registered trademarks of and licensed by Beckhoff Automation GmbH. Other designations used in this publication may be trademarks whose use by third parties for their own purposes could violate the rights of the owners.

tools / accessory parts	
crimping tool	crimping insert / locator
ZB8810-0000	ZB8810-0002