

# Montageanleitung B23 Hybrid

konfektionierbares Kupplungsgehäuse mit Crimpanschluss, axial,  
5x4mm<sup>2</sup> + 4xAWG22, ECP: Powerstift / Datenstift

## Stückliste

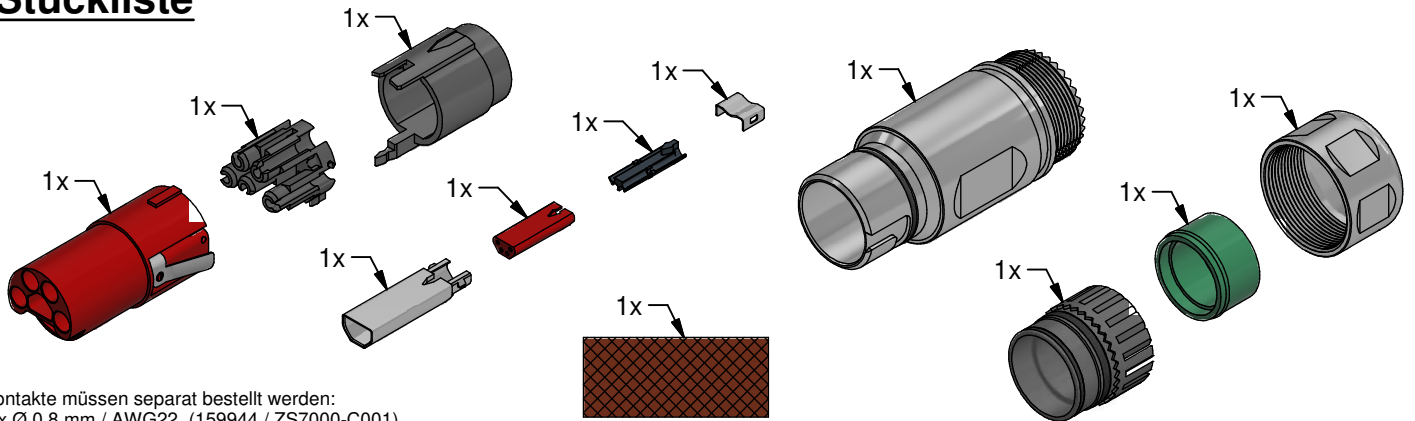

Kontakte müssen separat bestellt werden:  
4 x Ø 0,8 mm / AWG22 (159944 / ZS7000-C001)  
5 x Ø 2,25 mm / 4 mm<sup>2</sup> (159955 / ZS7000-C009)

**Laufrichtung beachten!**

1 Einzelteile auf Leitung schieben

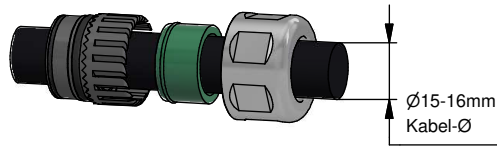

**Füllstoffe bündig mit Kabelmantel wegschneiden!**

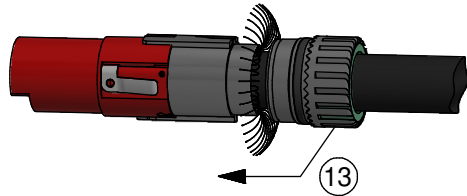
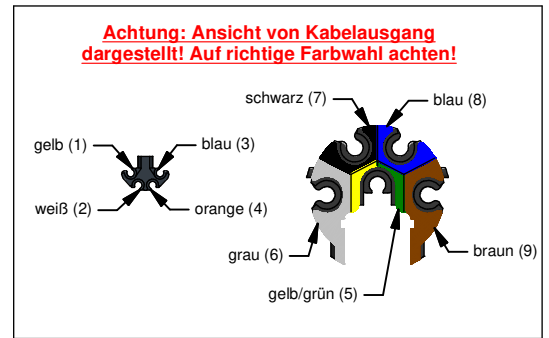
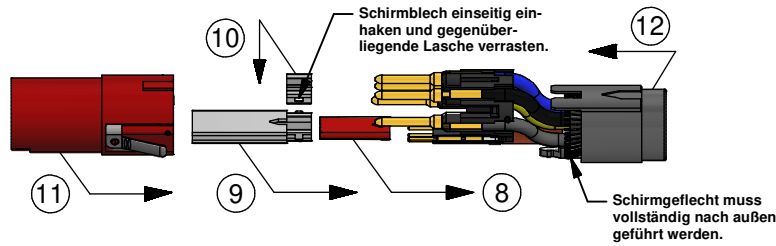
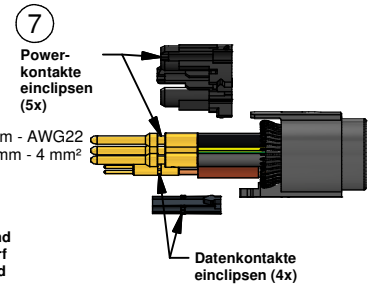
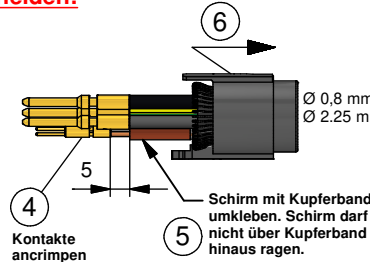
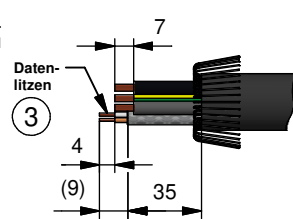
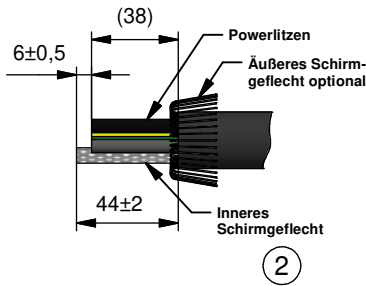

Codiernut für gewünschte Codierung wählen!

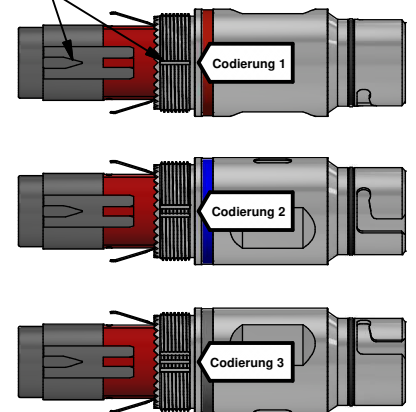

Farbring optional  
ZS7300-B005 (rot)  
ZS7300-B006 (gelb)  
ZS7300-B007 (blau)  
ZS7300-B008 (grün)

Schirmgeflecht muss gekürzt werden und darf nicht über zweiten O-Ring ragen!

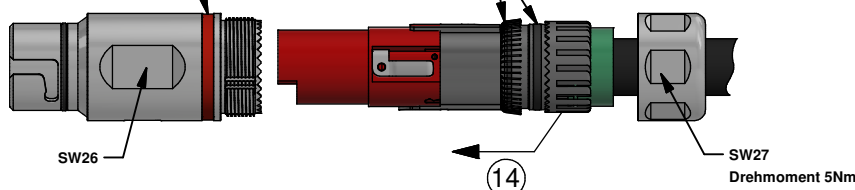

Beckhoff®, TwinCAT®, EtherCAT®, EtherCAT P®, Safety over EtherCAT®, TwinSAFE®, XFC® und XTS® sind eingetragene und lizenzierte Marken der Beckhoff Automation GmbH.  
Die Verwendung anderer in dieser Dokumentation enthaltenen Marken oder Kennzeichen durch Dritte kann zu einer Verletzung von Rechten der Inhaber der entsprechenden Kennzeichen führen.

© Beckhoff Automation GmbH & Co. KG 08/2016

790-983000 / 7901A549 Rev. a  
Beckhoff Art.-Nr.: ZS7300 - 0007

**BECKHOFF**

Die Informationen in dieser Druckschrift enthalten lediglich allgemeine Beschreibungen bzw. Leistungsmerkmale, welche im konkreten Anwendungsfall nicht immer in der beschriebenen Form zutreffen bzw. welche sich durch Weiterentwicklung der Produkte ändern können. Die gewünschten Leistungsmerkmale sind nur dann verbindlich, wenn sie bei Vertragsabschluss ausdrücklich vereinbart werden.

### Werkzeug / Zubehör

Crimpzange	Crimpeinsatz / Locator
ZB8810-0000	ZB8810-0002



# Assembly instruction B23 hybrid

field attachable coupling housing with crimp connection, axial.  
 5x4mm<sup>2</sup> + 4xAWG22, ECP: power (male) / data (male)

## parts list

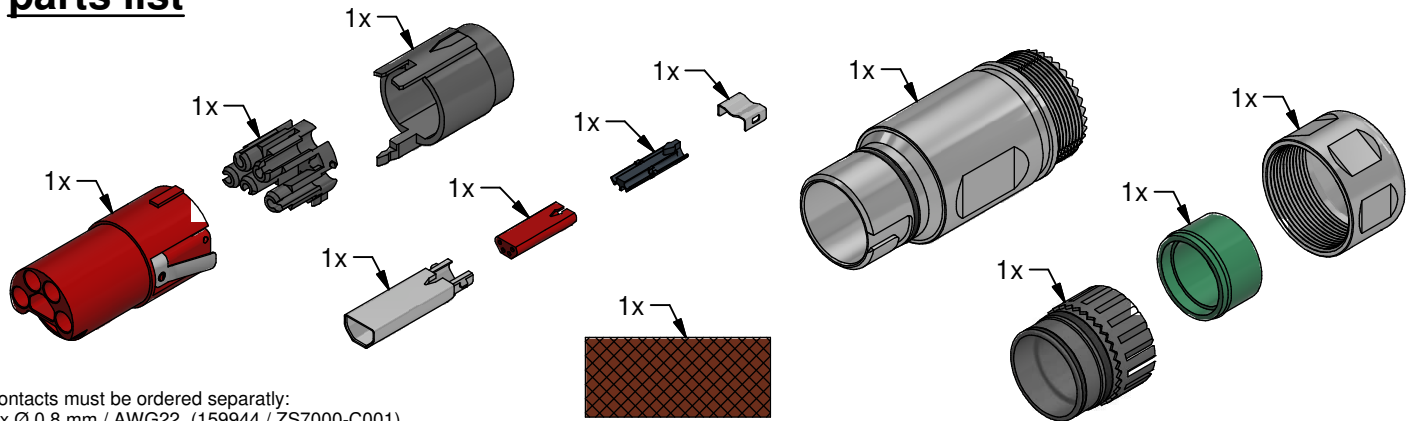

Contacts must be ordered separately:  
 4 x Ø 0,8 mm / AWG22 (159944 / ZS7000-C001)  
 5 x Ø 2,25 mm / 4 mm<sup>2</sup> (159955 / ZS7000-C009)

**1** insert parts onto the cable

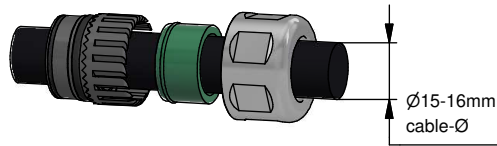

please consider the cable direction!

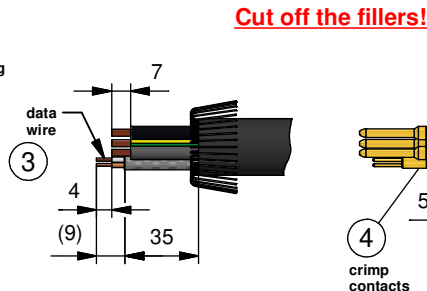
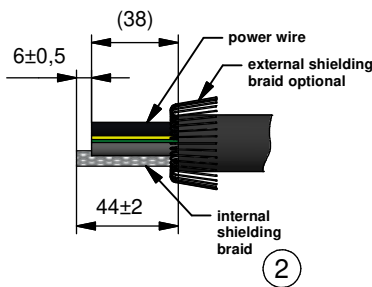

Cut off the fillers!

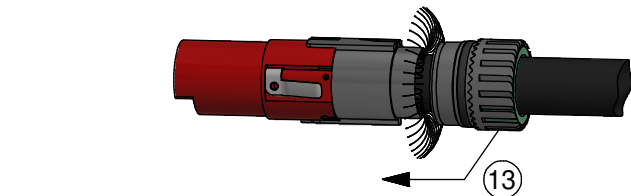
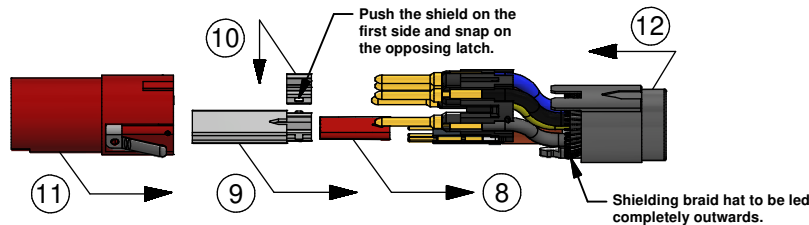
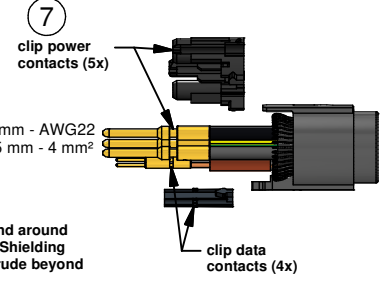
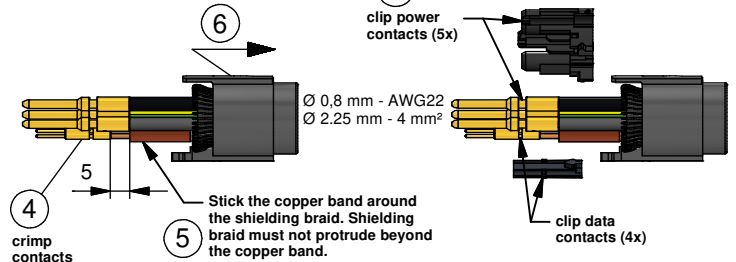

Attention: View from cable outlet!  
 Consider the right choice of colors!

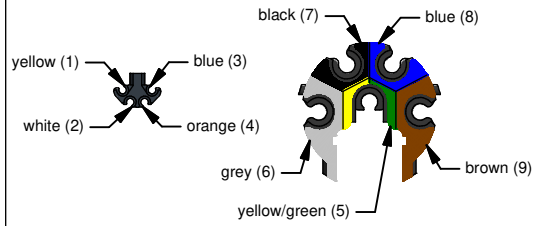

Color ring optional  
 ZS7300-B005 (red)  
 ZS7300-B006 (yellow)  
 ZS7300-B007 (blue)  
 ZS7300-B008 (green)

Shielding braid has to be shorten. It's not allowed to protrude above the second O-ring!

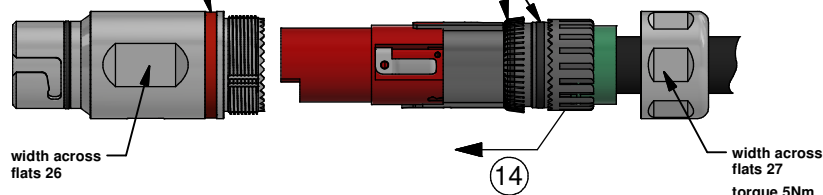

Select the right coding!

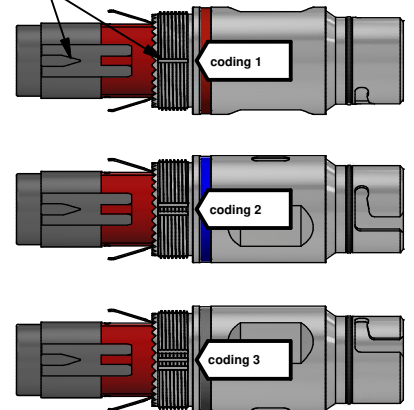

Beckhoff®, TwinCAT®, EtherCAT®, EtherCAT P®, Safety over EtherCAT®, TwinsAFE®, XFC® and XTS® are registered trademarks of and licensed by Beckhoff Automation GmbH. Other designations used in this publication may be trademarks whose use by third parties for their own purposes could violate the rights of the owners.

© Beckhoff Automation GmbH & Co. KG 08/2016

790-983000 / 7901A549 Rev. a  
 Beckhoff part.-no.: ZS7300 - 0007



The information provided in this brochure contains merely general descriptions or characteristics of performance which in case of actual application do not always apply as described or which may change as a result of further development of the products. An obligation to provide the respective characteristics shall only exist if expressly agreed in the terms of contract.

## tools / accessory parts

crimping tool	crimping insert / locator
ZB8810-0000	ZB8810-0002