

# Montageanleitung B17 Hybrid

konfektionierbares Kupplungsgehäuse mit Crimpanschluss, axial,  
4x1,5mm<sup>2</sup> + 4xAWG22, ECP: Powerstift / Datenstift

## Stückliste

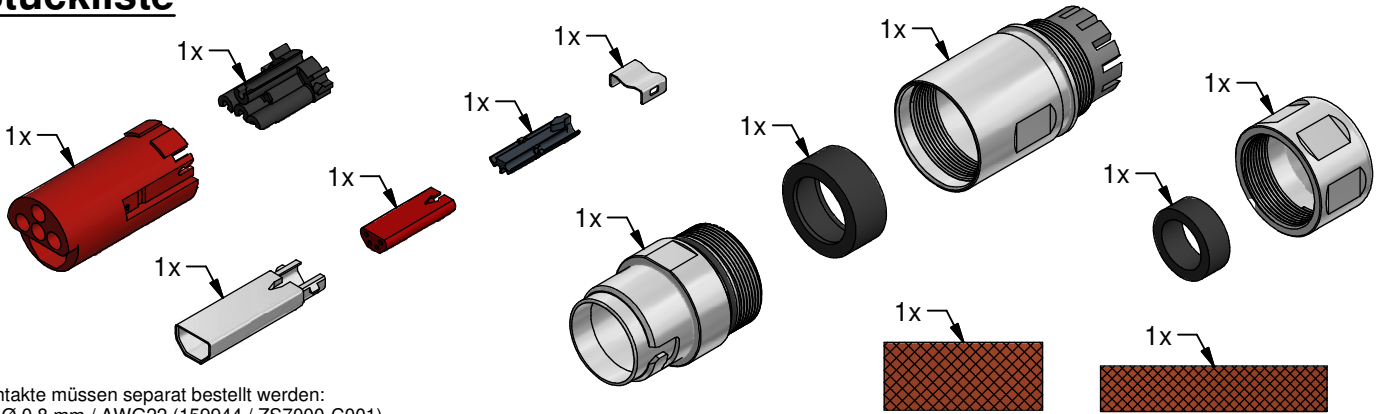

Kontakte müssen separat bestellt werden:  
4 x Ø 0,8 mm / AWG22 (159944 / ZS7000-C001)  
4 x Ø 1,5 mm / 1,5 mm<sup>2</sup> (159951 / ZS7000-C005)

**Laufriichtung beachten!**

1 Einzelteile auf Leitung schieben

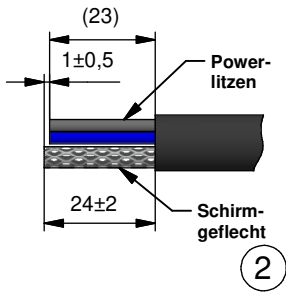
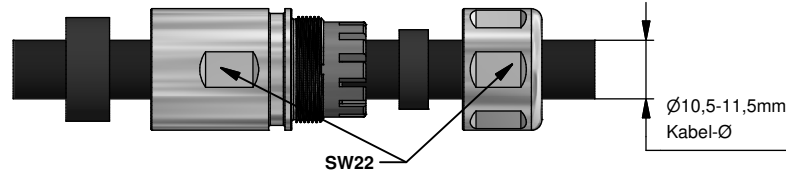

**Füllstoffe bündig mit Kabelmantel wegschneiden!**

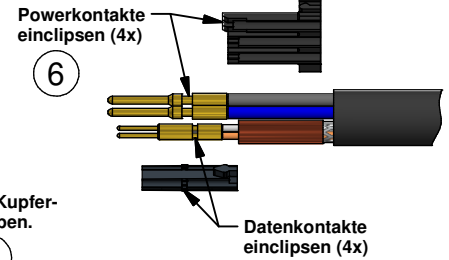
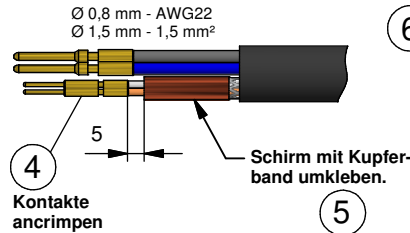
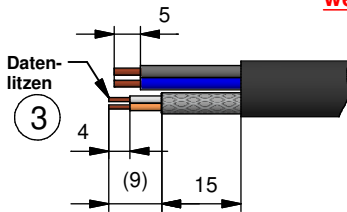

9 Schirmblech einseitig einhaken und gegenüberliegende Lasche verrasten.

Äußeres Schirmgeflecht optional. Schirmgeflecht stramm nach hinten ziehen.

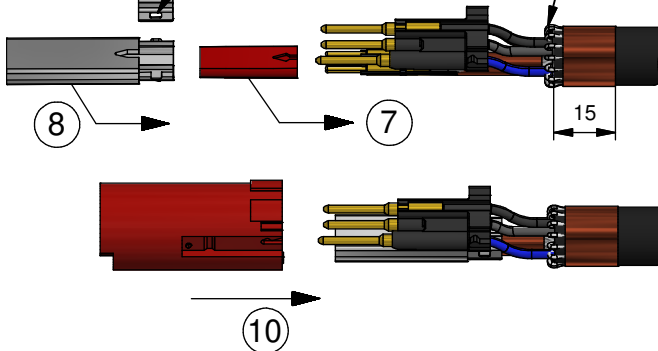

**Achtung: Ansicht von Kabelausgang dargestellt! Auf richtige Farbwahl achten!**

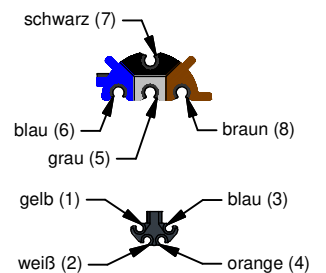

Codierung 2

Codierung 1

Codierung 3

**Nur eine Codierung montierbar!**

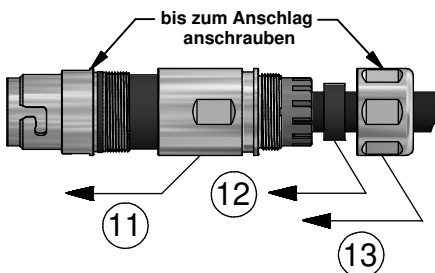

Farbring optional  
ZS7200-B005 (rot)  
ZS7200-B007 (blau)  
ZS7200-B016 (grau)

### Werkzeug / Zubehör

Crimpzange

Crimpeinsatz / Locator

ZB8810-0000

ZB8810-0001

**BECKHOFF**

790-952800 / 7901A151 Rev. a  
Beckhoff Art.-Nr.: ZS7200 - 0011

# Assembly instruction B17 hybrid

field attachable coupling housing with crimp connection, axial,  
4x1.5mm<sup>2</sup> + 4xAWG22, ECP: power (male) / data (male)

## parts list

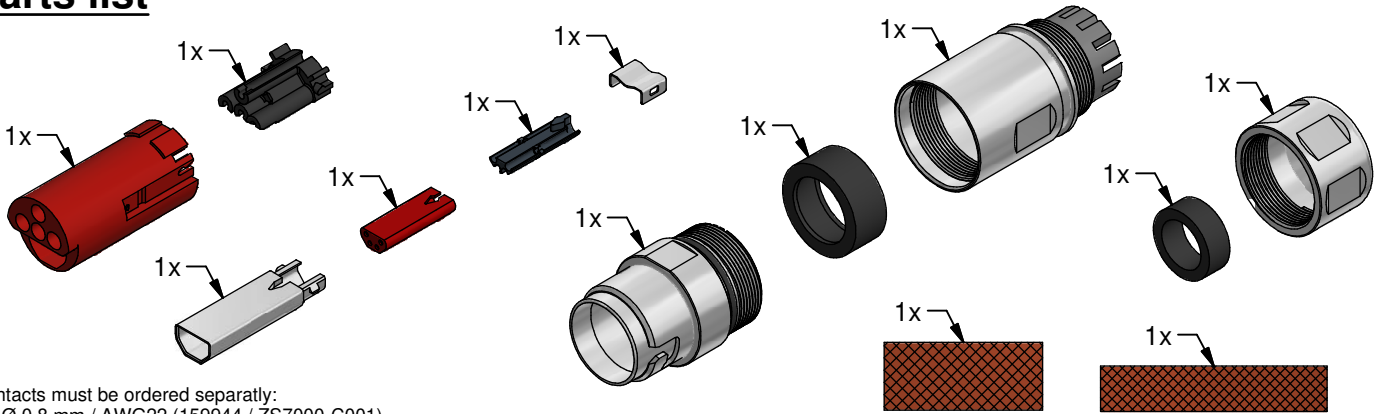

Contacts must be ordered separately:  
4 x Ø 0.8 mm / AWG22 (159944 / ZS7000-C001)  
4 x Ø 1.5 mm / 1.5 mm<sup>2</sup> (159951 / ZS7000-C005)

Please consider the cable direction!

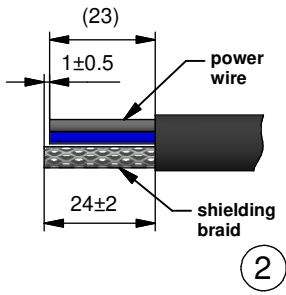
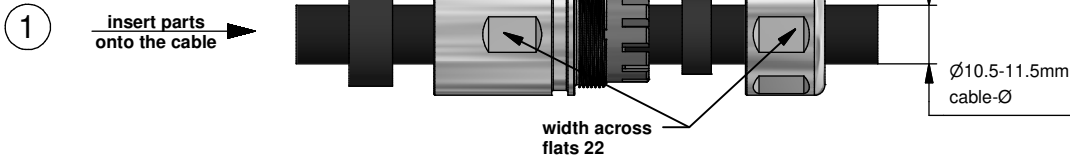

Cut off the fillers!

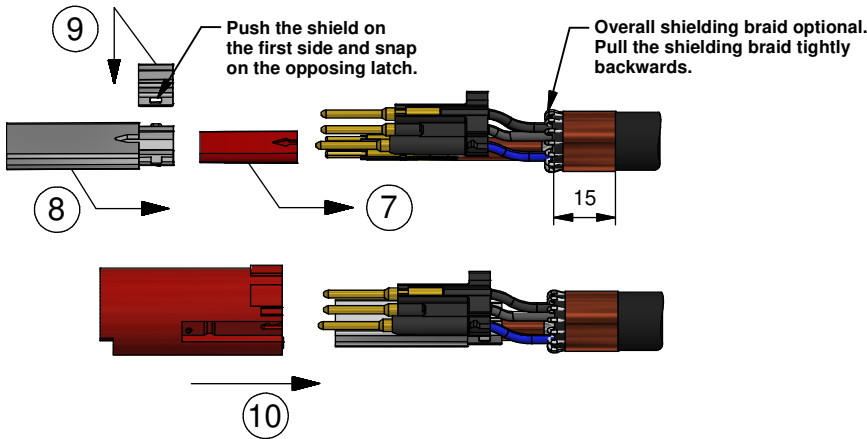
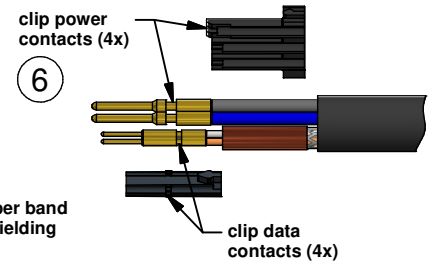
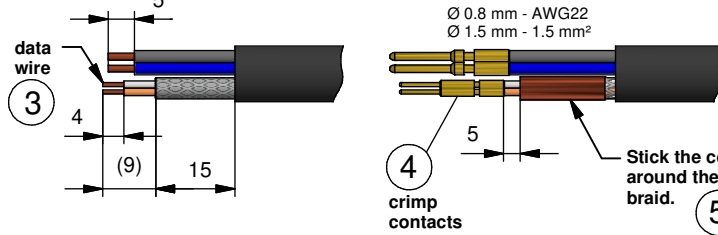

Attention: View from cable outlet!  
Consider the right choice of colors!

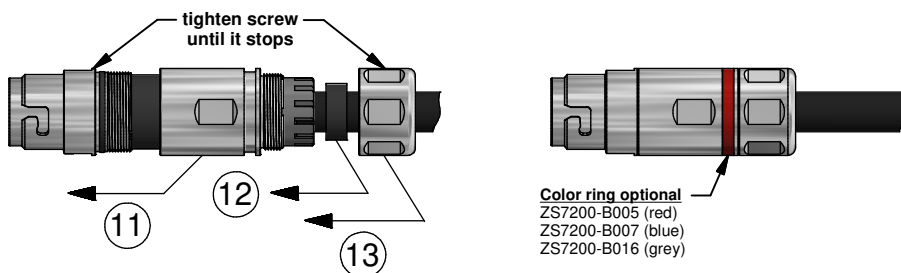
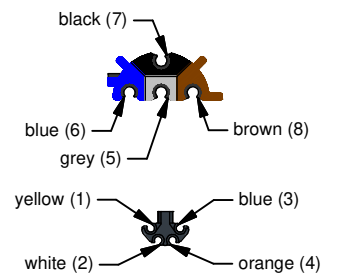

Color ring optional  
ZS7200-B005 (red)  
ZS7200-B007 (blue)  
ZS7200-B016 (grey)

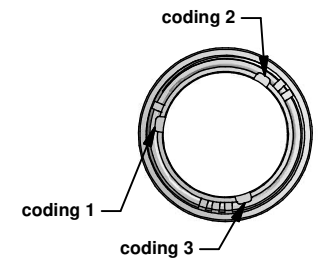

Only one coding mountable!

Beckhoff®, TwinCAT®, EtherCAT®, EtherCAT P®, Safety over EtherCAT®, TwinSAFE®, XFC® and XTS® are registered trademarks of and licensed by Beckhoff Automation GmbH. Other designations used in this publication may be trademarks whose use by third parties for their own purposes could violate the rights of the owners.

© Beckhoff Automation GmbH & Co. KG 08/2016

The information provided in this brochure contains merely general descriptions or characteristics of performance which in case of actual application do not always apply as described or which may change as a result of further development of the products. An obligation to provide the respective characteristics shall only exist if expressly agreed in the terms of contract.

## tools / accessory parts

crimping tool	crimping insert / locator
ZB8810-0000	ZB8810-0001

**BECKHOFF**

790-952800 / 7901A151 Rev. a  
Beckhoff art.-no.: ZS7200 - 0011