

Kontaktbelegung/Polbild

PIN-Nummer	Aderfarbe	Querschnitt
1	gelb	26 - 20 AWG
2	weiß	
3	blau	
4	orange	

Option: Ader mit / ohne Aderendhülse

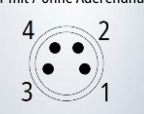

Anschlussseite

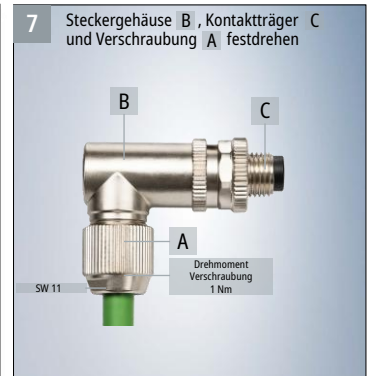
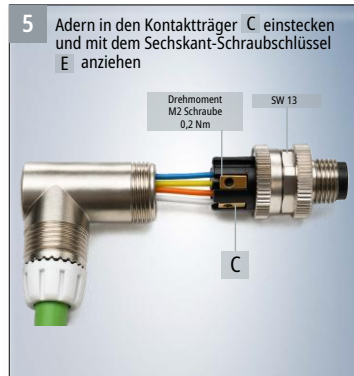

Assembly Instruction

ZS1090-1016 | Connector, field-assembled, shielded, M8, plug, angled, male, 4 pin, EtherCAT A-coded

Revision 1.0

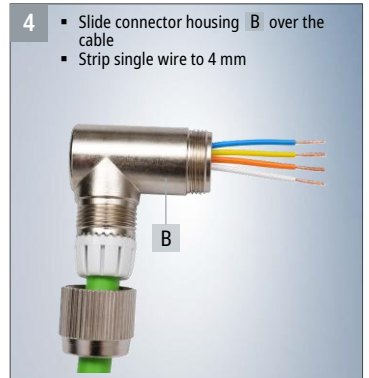
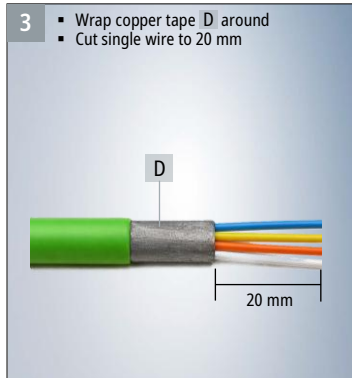
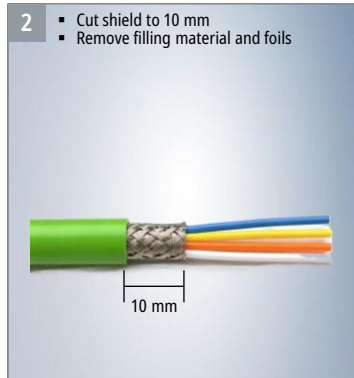
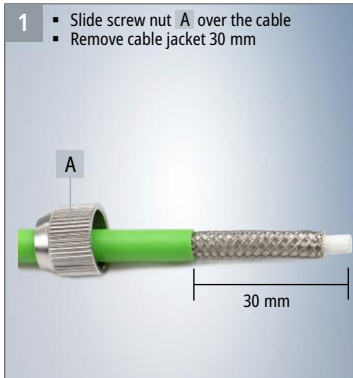
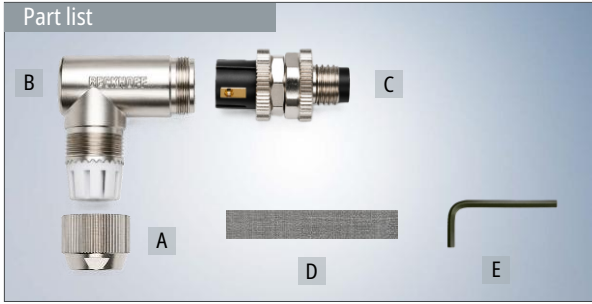

Pin Assignment/Pin Layout

Pin	Wire Color	Cross-section
1	yellow	26 - 20 AWG
2	white	
3	blue	
4	orange	

Option: Single wire with / without ferrule

Connection side

