

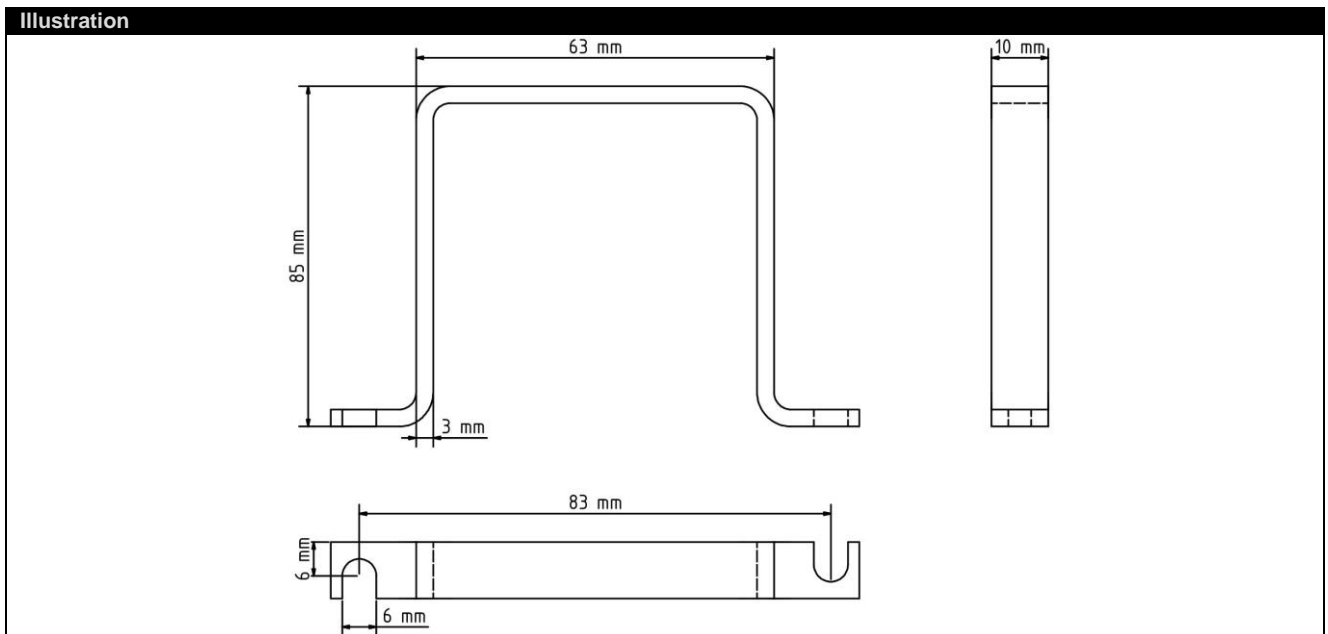

ZB8512 | Shield busbar clamp 85 x 10 x 3 mm for 5 Bus terminals/EtherCAT Terminals with and without fan cartridge ZB8610

Material	Copper, tin plated
Weight	Ca. 100 g
Conformity	RoHS



Ordering information	Description
ZB8512	Shield busbar clamp 85 x 10 x 3 mm for 5 Bus terminals/EtherCAT Terminals with and without fan cartridge ZB8610 packing unit = 10 pieces