

(*) Customer can cut the conduit to the desired length
 minimal bending radius of conduit:
 fixed installation: 100 mm
 moving installation: 135 mm

minimal bending radius of hybrid-cable:
 fixed installation: 80 mm
 moving installation: 165 mm

Please note that the hybrid-cable is not declared to be cable chain suitable!

Take missing dimensions from the 3D-model
 The drawing and the 3D-model show simplified geometry

Cable and Conduit Length Variations of ATH2042-0250-0xx0					
Description	Item No.	Nominal Cable Length [m]	Dimension "A" [m]	Dimension "B" [m]	Weight [kg]
ATH2042-0250-0040	249485	4	0,75	3	6,7
ATH2042-0250	249444	8	1,75	6	7,9
ATH2042-0250-0160	249305	16	0,75	15	10,3
ATH2042-0250-0250	249311	25	0,75	24	12,9

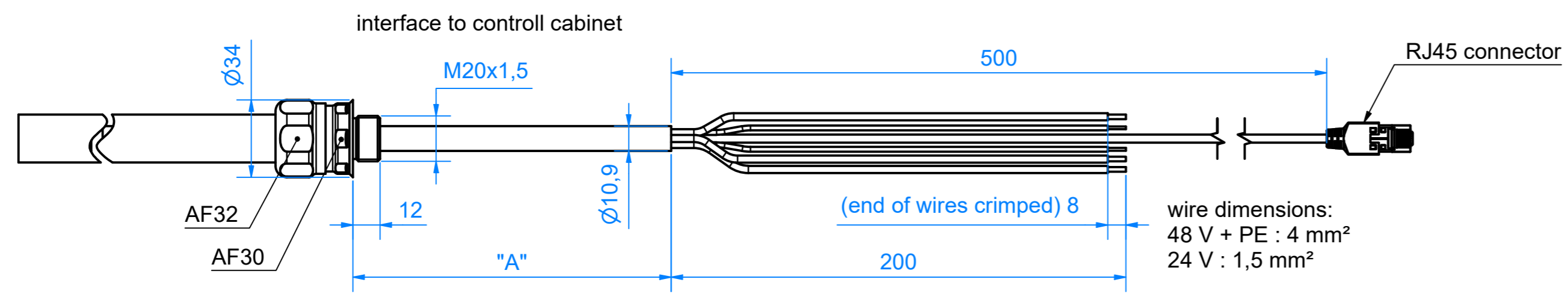

wire dimensions:
 48 V + PE : 4 mm²
 24 V : 1,5 mm²

00	eingeführt / introduced	20.05.2022	AndreasSi		
Index	Änderungsbeschreibung / description of change	Änderungsnummer / change number	Erstelldatum / create date	Veranlasser / Initiator / name of creator	Freigabedatum / release date
Werkstoff / material	Masse / mass see table Dichte / density	Tolerierung / toleration Allgemeintoleranz / general tolerances ISO 8015 ISO 2768 - FH			
Oberfläche / surface	Fläche / area Volumen / volume	Werkstückkanten / edges Oberflächenangaben / indication of surface Tolerierung von Form, Richtung, Ort, Lage / tolerances of form, orientation, location, run out DIN EN ISO 13715 DIN EN ISO 1302 DIN EN ISO 1101			
Bezeichnung / description	ATH2042-0250-0xx0		Artikelnummer / item number	Revision 3D	
Ursprung / source:	Freigabestatus / release state:	Revision 2D			
BECKHOFF New Automation Technology		Beckhoff Automation GmbH & Co. KG Hülshorstweg 20 / 33415 Verl Tel.: +49/5246/963-0 / info@beckhoff.com		Werknorm company standard BAIN-A BAIN-C BAIN-M	RoHS konform RoHS compliant 2011/65/EU 2015/863/EU
ISO 128		Maßeinheit dimension scale	Maßstab scale	Blattgröße sheet size	Blatt sheet
mm		1 : 2	A2	1 / 2	

Copyright reserved to ISO 16916
 The property and copyright of this drawing remains the property of Beckhoff Automation GmbH & Co. KG.
 It is entrusted to you as the recipient for personal use only. Without a written permission from Beckhoff Automation GmbH & Co. KG
 this may not be copied and reproduced, or sent and made accessible to third parties, especially competitors.
 Doing so is obliged to pay compensation.
 Schutzrecht nach DIN ISO 16916 beachten
 Das Eigentums- und Urheberrecht an dieser Zeichnung verbleibt der Firma Beckhoff Automation GmbH & Co. KG. Sie sind Ihnen als
 Empfänger nur zum persönlichen Gebrauch anvertraut. Ohne eine schriftliche Genehmigung der Firma Beckhoff Automation GmbH & Co. KG
 darf diese nicht kopiert und vervielfältigt, und auch nicht dritten Personen, insbesondere Wettbewerbern, mitgeteilt oder zugänglich gemacht werden.
 Ein Zuwiderhandeln verpflichtet zum Schadensersatz.