

Manual | EN

MR1310-0031-2242

3-channel relay, replaceable fuses, 230/277 V AC/10 A, residual current measurement, M12

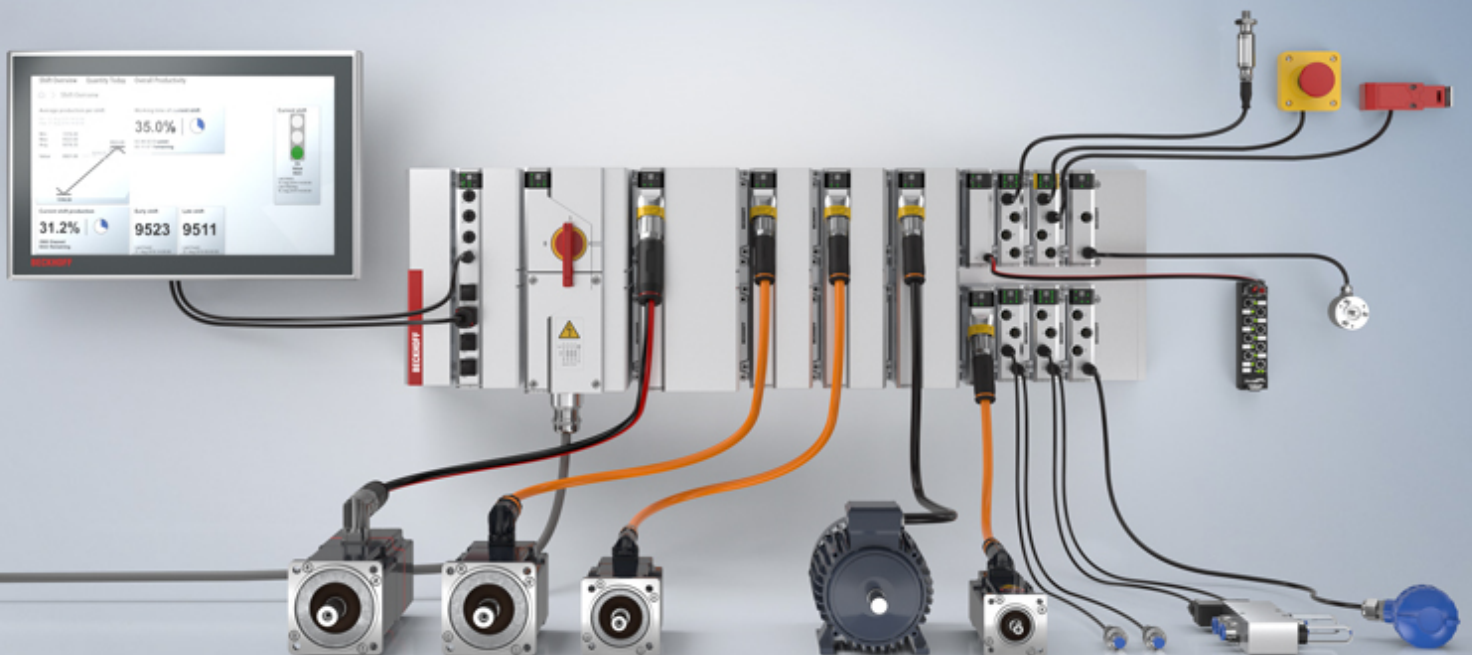

Table of contents

1 Foreword	5
1.1 Notes on the documentation	5
1.2 For your safety	6
1.3 Intended use	7
1.4 Safety instructions	7
2 Product overview	8
2.1 Product functions	10
2.2 Block diagram	11
2.3 Type key.....	12
2.4 Status display	13
2.5 Dimensions	14
3 Technical data	15
4 Mechanical installation	17
4.1 Preparation.....	17
4.2 Placement of the module on the baseplate	18
4.3 Mounting the module.....	19
5 Connection	20
5.1 Principles.....	20
5.2 Digital combi channels	21
5.3 Relay outputs	23
6 Commissioning and operation	24
6.1 During operation.....	24
6.1.1 Replacing the fuses.....	24
7 Software functions	28
7.1 Digital input	28
7.2 Digital output	29
7.5 Relay output	31
8 Decommissioning	32
8.1 Disassembly	32
8.2 Disposal	32
9 Appendix	33
9.1 CoE parameters	33
9.2 Manual version history	34
9.3 Support and Service.....	35
9.4 Accessories	36

1 Foreword

1.1 Notes on the documentation

This description is intended exclusively for trained specialists in control and automation technology who are familiar with the applicable national standards.

The documentation and the following notes and explanations must be complied with when installing and commissioning the components.

The trained specialists must always use the current valid documentation.

The trained specialists must ensure that the application and use of the products described is in line with all safety requirements, including all relevant laws, regulations, guidelines, and standards.

Disclaimer

The documentation has been compiled with care. The products described are, however, constantly under development.

We reserve the right to revise and change the documentation at any time and without notice.

Claims to modify products that have already been supplied may not be made on the basis of the data, diagrams, and descriptions in this documentation.

Trademarks

Beckhoff®, ATRO®, EtherCAT®, EtherCAT G®, EtherCAT G10®, EtherCAT P®, MX-System®, Safety over EtherCAT®, TC/BSD®, TwinCAT®, TwinCAT/BSD®, TwinSAFE®, XFC®, XPlanar®, and XTS® are registered and licensed trademarks of Beckhoff Automation GmbH.

If third parties make use of the designations or trademarks contained in this publication for their own purposes, this could infringe upon the rights of the owners of the said designations.

EtherCAT 

EtherCAT® is a registered trademark and patented technology, licensed by Beckhoff Automation GmbH, Germany.

Copyright

© Beckhoff Automation GmbH & Co. KG, Germany.

The distribution and reproduction of this document, as well as the use and communication of its contents without express authorization, are prohibited.

Offenders will be held liable for the payment of damages. All rights reserved in the event that a patent, utility model, or design are registered.

Third-party trademarks

Trademarks of third parties may be used in this documentation. You can find the trademark notices here: <https://www.beckhoff.com/trademarks>.

1.2 For your safety

Safety regulations

Read the following explanations for your safety.

Always observe and follow product-specific safety instructions, which you may find at the appropriate places in this document.

Exclusion of liability

All the components are supplied in particular hardware and software configurations which are appropriate for the application. Modifications to hardware or software configurations other than those described in the documentation are not permitted, and nullify the liability of Beckhoff Automation GmbH & Co. KG.

Personnel qualification

This description is only intended for trained specialists in control, automation, and drive technology who are familiar with the applicable national standards.

Signal words

The signal words used in the documentation are classified below. In order to prevent injury and damage to persons and property, read and follow the safety and warning notices.

Personal injury warnings

DANGER

Hazard with high risk of death or serious injury.

WARNING

Hazard with medium risk of death or serious injury.

CAUTION

There is a low-risk hazard that could result in medium or minor injury.

Warning of damage to property or environment

NOTICE

The environment, equipment, or data may be damaged.

Information on handling the product



This information includes, for example:
recommendations for action, assistance or further information on the product.

1.3 Intended use

This documentation describes a module designed to supply individually switchable phases of the three-phase AC voltage of the MX system. It may only be operated if it is mounted on a baseplate in accordance with the installation instructions in this manual and the fuse cover is closed.

With the exception of the fuse cover, the housing must not be opened by the user. There are no user-serviceable parts inside the housing. The housing screws on the bottom of the module may only be loosened by Beckhoff Service.

Intended use of an MX-System

Application in machines and systems in industrial environments and exclusively inside buildings.

The electrical wiring must be permanent wiring.

Improper use

Improper use is not permitted and will result in the exclusion of liability on the part of Beckhoff Automation GmbH & Co.

1.4 Safety instructions

This module works with a life-threatening voltage. Work on the module may only be carried out in a de-energized state.

2 Product overview

The MR1310-0031-2242 relay module is used to connect ohmic or inductive 1-phase AC loads. Each of the three relay outputs carries one phase together with the neutral conductor to the outside and can switch up to 10 A. Connection is via M12 connectors.

The fuses for line protection are accessible and replaceable via a fuse flap on the side.

In addition, the MR1310-0031-2242 has six digital channels on three separate M12 connectors, each of which can be operated as inputs or outputs. Differential current measurement is also integrated.

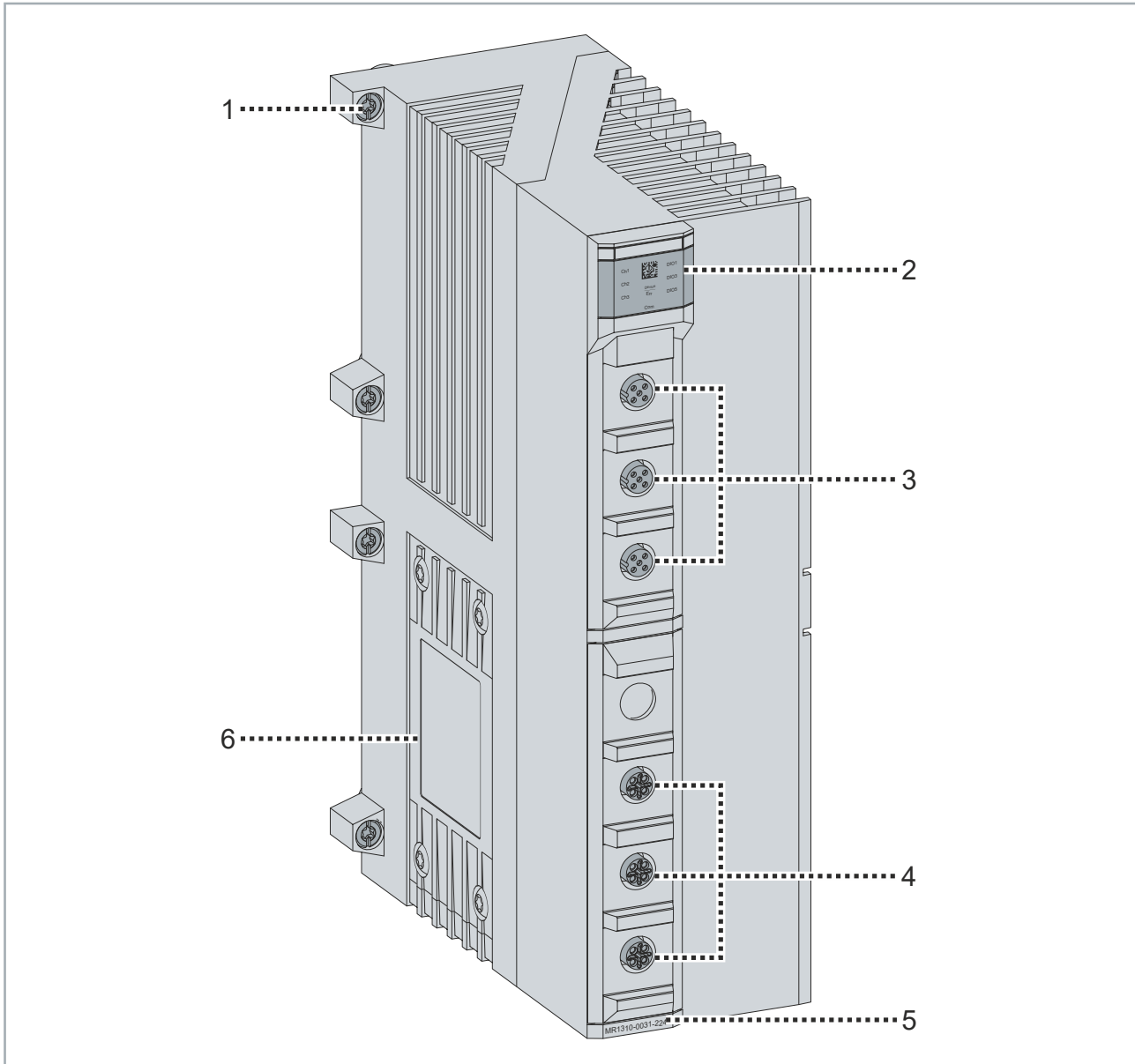

Position	Name
1	Fastening screw, captive, 8 x
2	Status display
3	Digital combi channels
4	Relay outputs
5	Module name
6	Safety flap

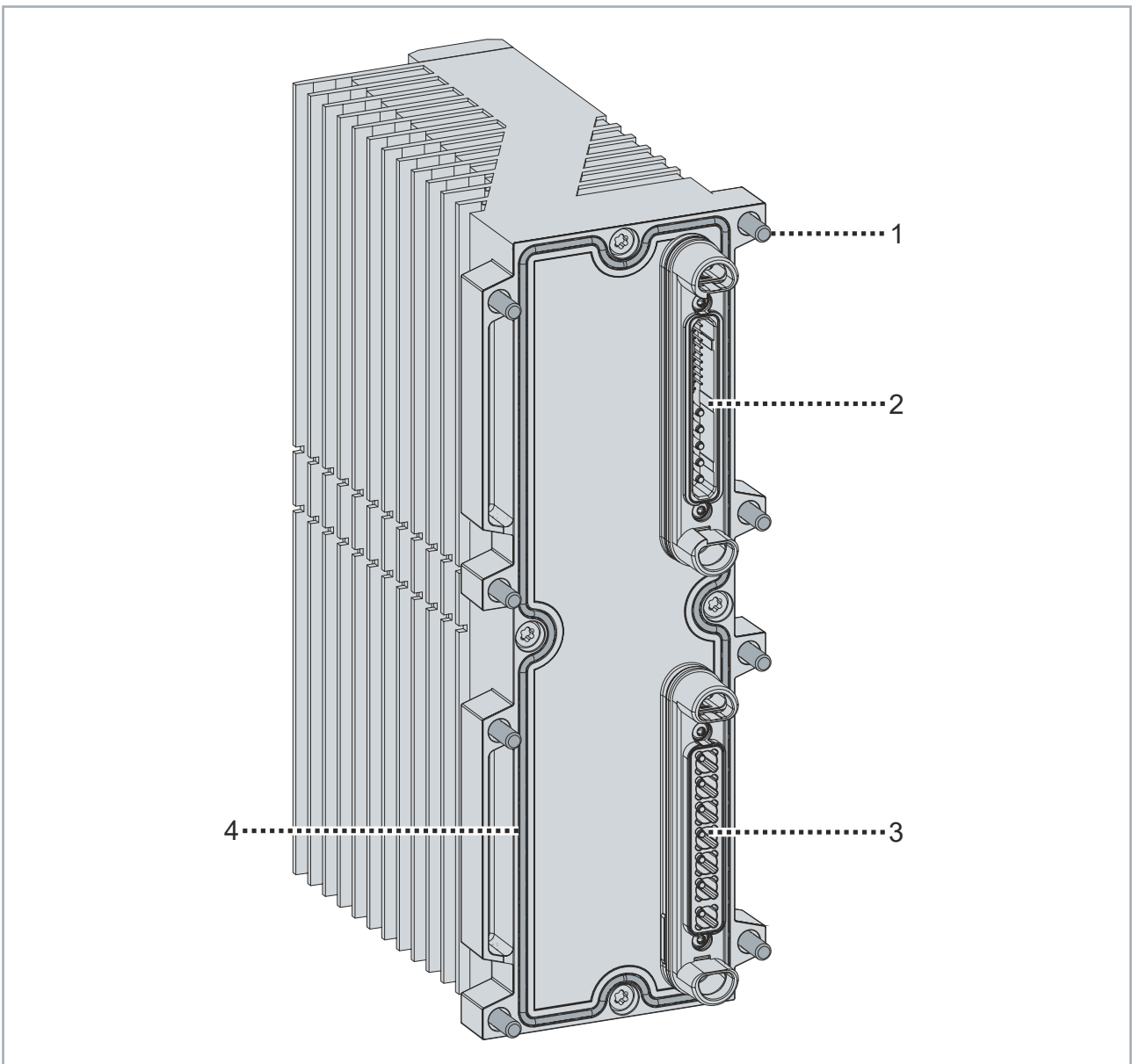

Position	Name
1	Fastening screw, captive, 8 x
2	Data connector
3	Power connector
4	Seal

2.1 Product functions

2.1.1 Relay outputs

One phase of the internal three-phase AC voltage and the neutral conductor are available at each relay output. The phase can be switched via a relay.

- [Connection \[► 23\]](#)
- [Relevant software function \[► 31\]](#)

2.1.2 Digital combi channels

The module has six digital combi channels. Each digital combi channel can be used either as a digital input or as a digital output.

- [Connection \[► 21\]](#)
- Relevant software functions: [Digital input \[► 28\]](#) and [digital output \[► 29\]](#)

A supply voltage output is also available on each digital combi channel. All three supply voltage outputs are protected by a common electronic fuse. The corresponding software function is described in the chapter .

2.1.3 Differential current measurement

The differential current measurement can be used for residual current monitoring. Configuration and evaluation are carried out using the software function [Relay output \[► 31\]](#).

2.2 Block diagram

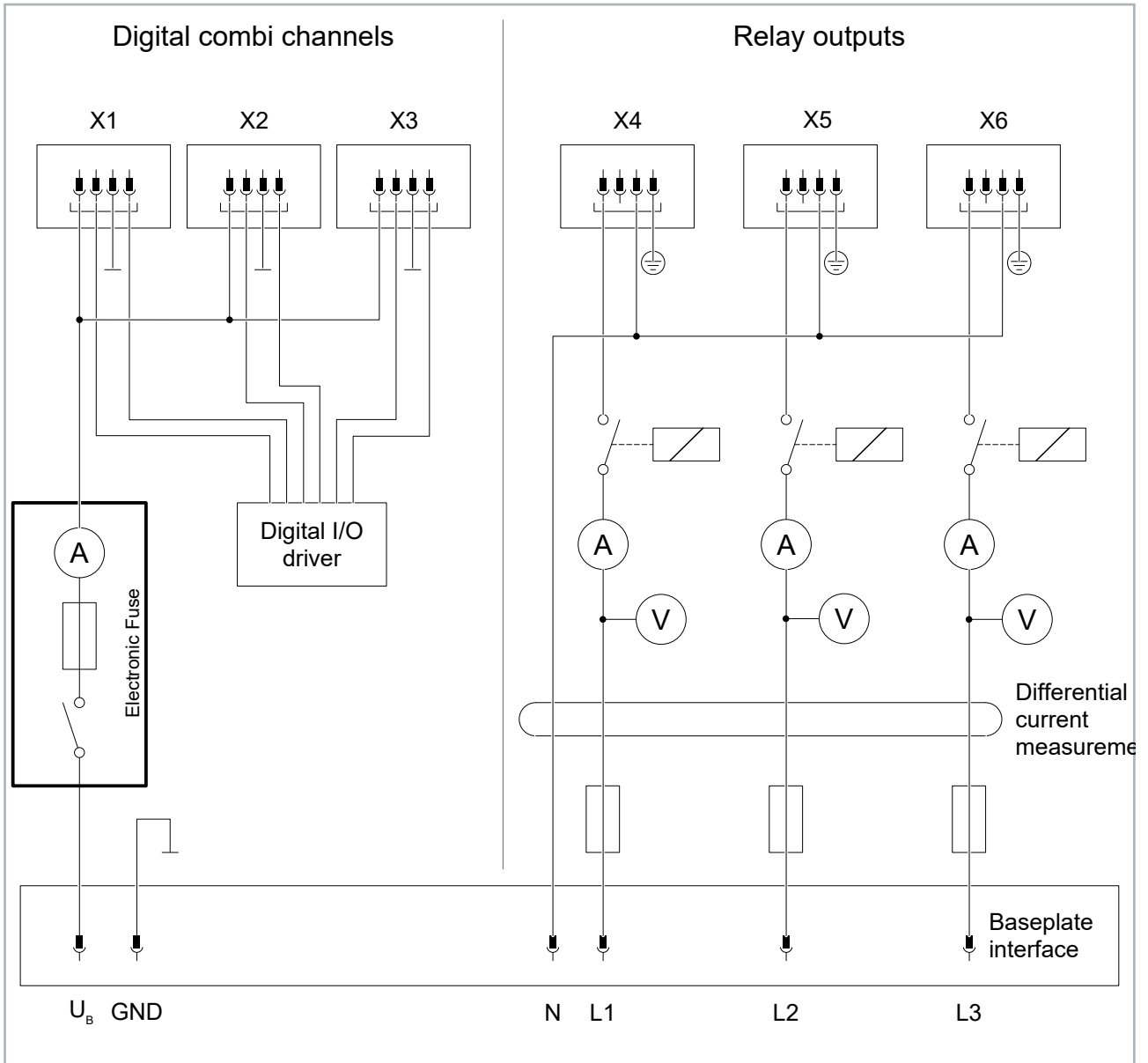

2.3 Type key

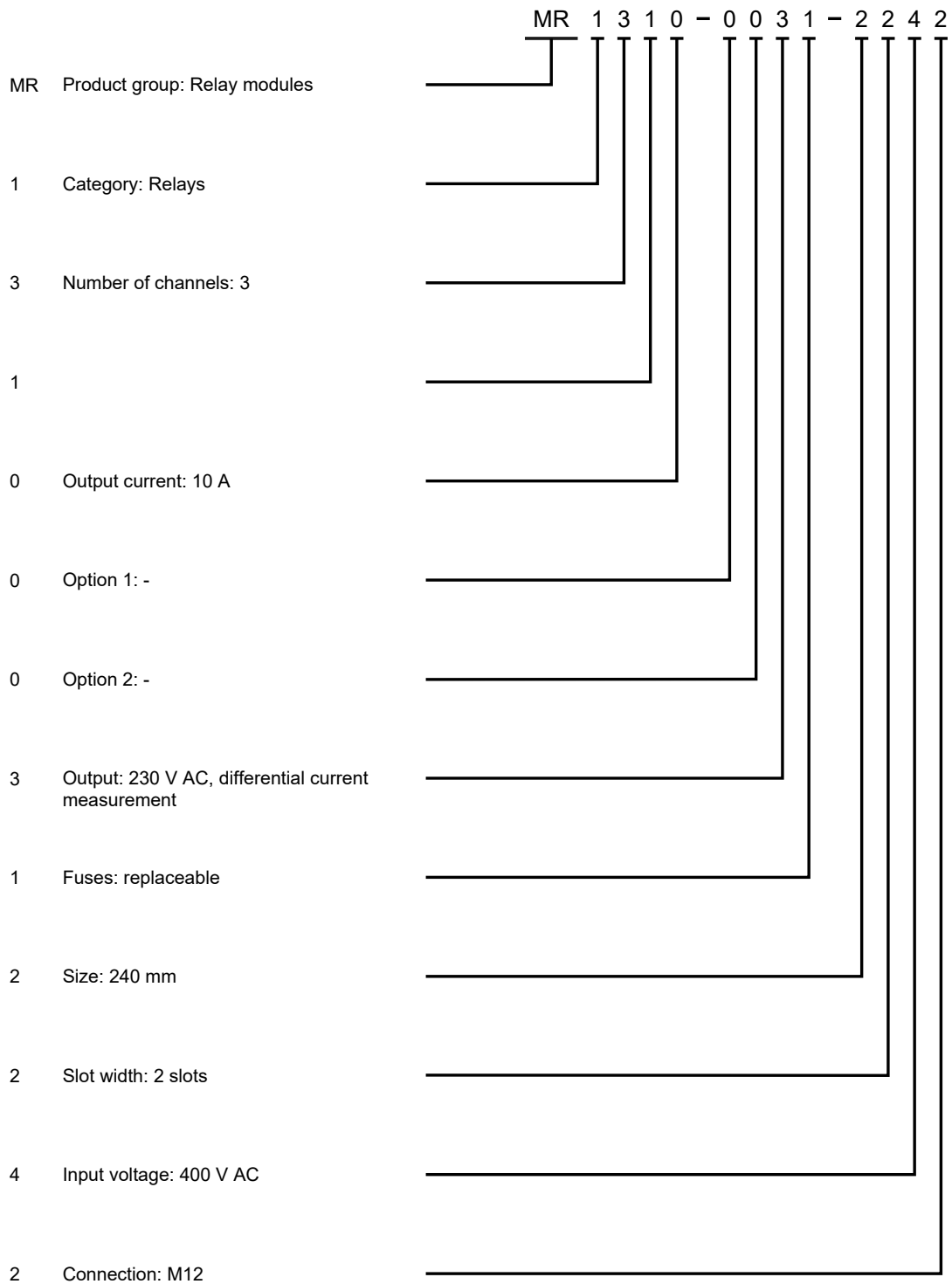

2.4 Status display

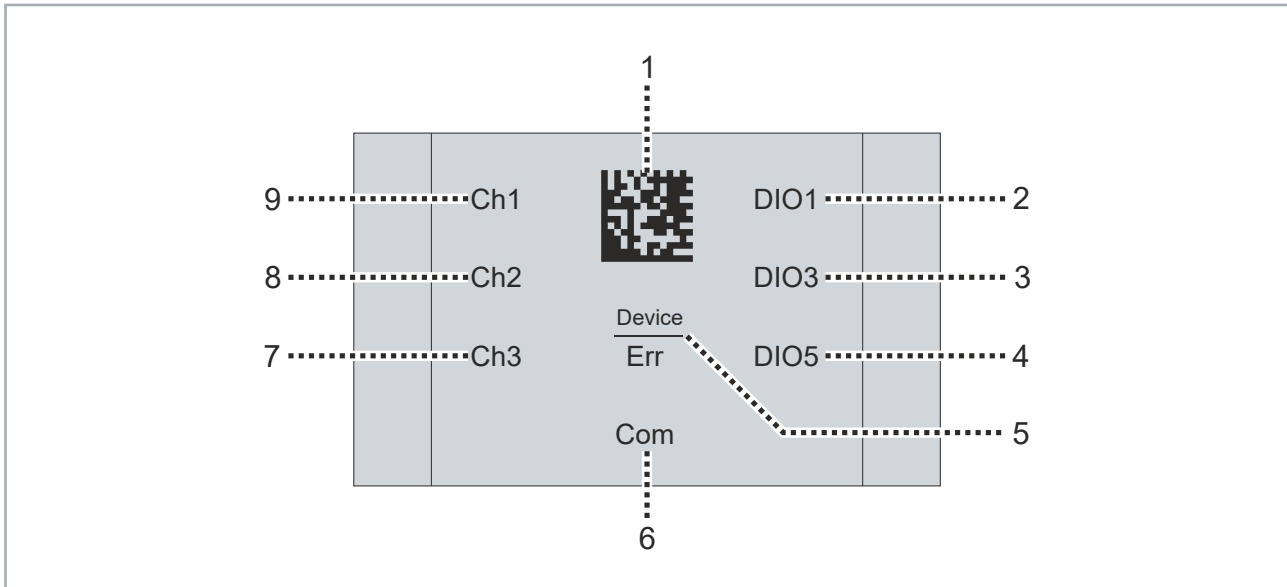

Position	Status display	Status	Explanation
1	-	-	BIC Beckhoff Identification Code ¹⁾
2	DIO1	green illuminated	High level on digital combi channel X1
3	DIO3	green illuminated	High level on digital combi channel X2
4	DIO5	green illuminated	High level on digital combi channel X3
5	Err	Off	No errors
		red illuminated	Error
6	Com	green illuminated	„Communication“ Displays the status of communication to the baseplate.
7	Ch3	green illuminated	Relay output X6 (phase L3) is switched on
8	Ch2	green illuminated	Relay output X5 (phase L2) is switched on
9	Ch1	green illuminated	Relay output X4 (phase L1) is switched on

¹⁾ Further information can be found at www.beckhoff.com/bic

2.5 Dimensions

All dimensions in mm

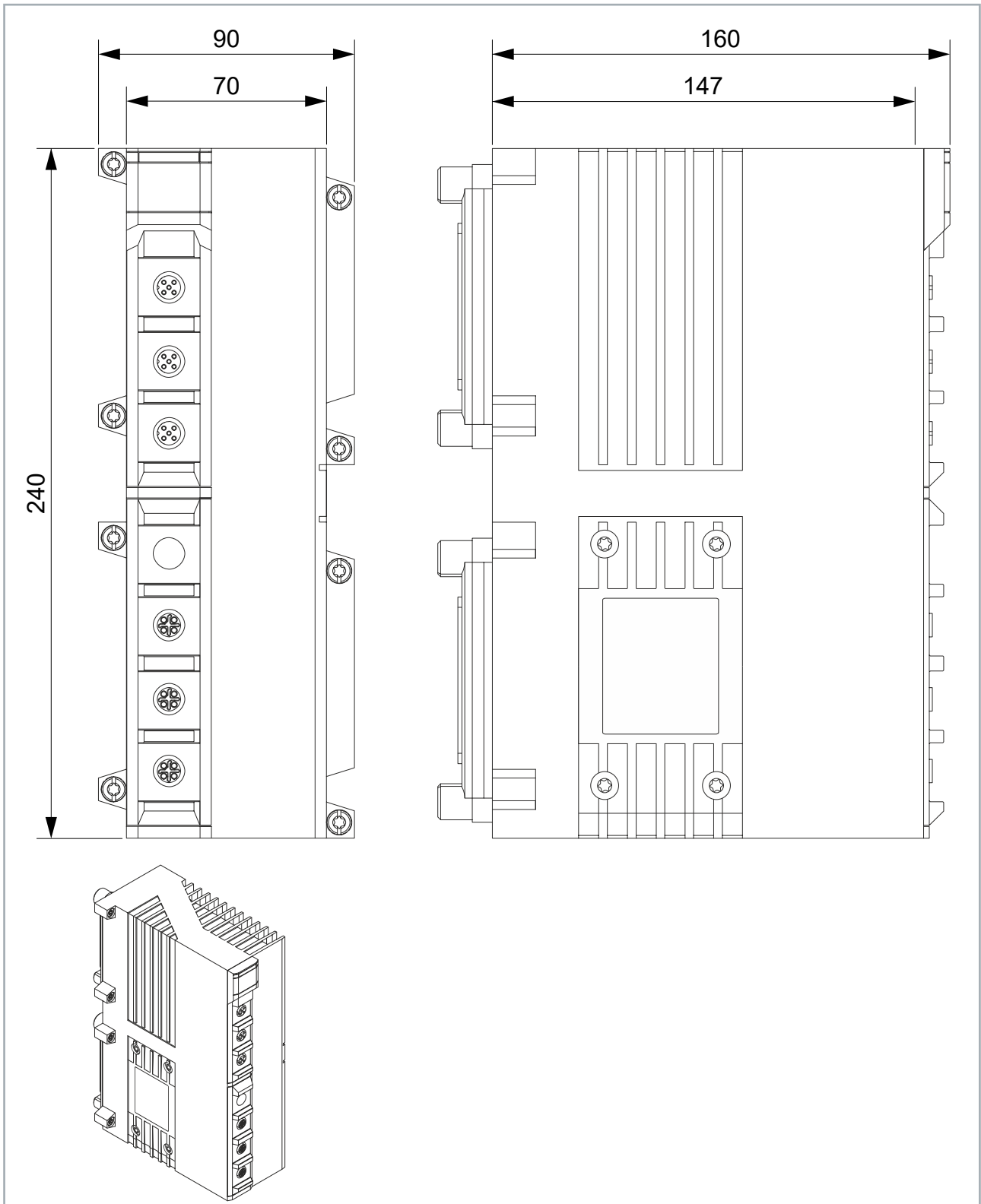

3 Technical data

All values are typical values over the entire temperature range, unless stated otherwise.

Baseplate interface	
Connector	<ul style="list-style-type: none"> • 1 data connector • 1 power connector
Hot Swap	No
Current consumption 3.3 V	3 mA
EtherCAT	Without distributed clocks

Input voltage AC	
Input voltage range	230 ... 277 V (-15 % ... +10 %)
Input current	7 A per phase 15 A in total
Frequency	50 ... 60 Hz (±10 %)

Relay outputs	
Connection	3 x M12 socket, 4-pin, S-coded
Load type	Ohmic, inductive
Output voltage	230...277 V AC (-15 % / + 20 %) from the baseplate
Output current	max. 10 A per phase

Fuse per phase	Replaceable, 16 A, 600 V AC, gRL Fuse 10.3x38 fine 16 A 600 V AC (SIBA 60 034 34.16)
----------------	--

Switching frequency	max. 6/min at 7 A output current max. 300/min without load
Switching cycles	Electrical (under load): 100,000 Mechanical (without load): 20 million
Current full scale value	24.42 A
Current measurement measurement uncertainty	1.25 % of full scale value

Digital combi channels	
Number of channels	6
Connection	3 x M12 socket, 5-pin, A-coded
Signals per connector	24 V DC (eFuse) 2 x digital In/Out
Electronic fuse protection voltage output (eFuse)	4 A or 100 W

Housing data	
Width (slots)	2
Height (rows)	2
Dimensions W × H × D	90 mm × 240 mm × 152 mm (housing only)
Material	Zinc die-cast and aluminum die-cast
Cooling	Convection
Installation position	Vertical. See system manual, chapter "Installation conditions".

Environmental conditions	
Operating temperature	0 ... 50 °C
Storage temperature	-25 ... +60 °C
Air humidity	95 %, no condensation
Protection rating	IP20 as a separate module IP65 / IP67 as part of a fully and correctly assembled MX-System
Pollution degree	2
Overvoltage category	III
Maximum installation altitude	2000 m

Device safety	
Separation between main and control circuits	Double or reinforced electrical isolation
Protection class	I

Standards, approvals	
Device safety	conforms to EN 61010-2-201
EMC immunity/emission	conforms to EN IEC 61000-6-2 / EN IEC 61000-6-4
Vibration/shock resistance	conforms to EN 60068-2-6 / EN 60068-2-27
Approvals	CE, UL in preparation

4 Mechanical installation



Required tools

- Torx T25 screwdriver
- Torque wrench 5 Nm

4.1 Preparation

NOTICE

Check the module for damage

If the seal is worn or damaged, liquids and dirt can penetrate and damage the MX-System. The IP65/IP67 protection rating is not met if the seals are worn or damaged.

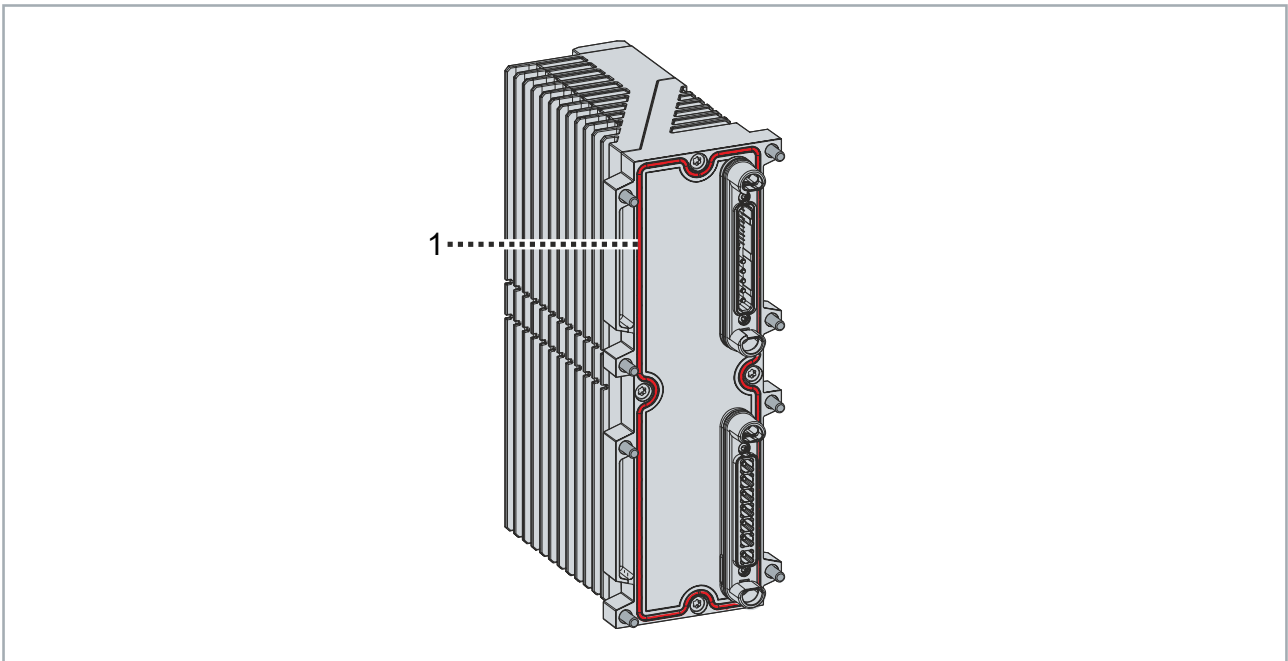

1. Check the seal [1] of the module for wear and damage
2. Replace worn and damaged seals

4.2 Placement of the module on the baseplate

The module can be plugged into the following areas marked in green:

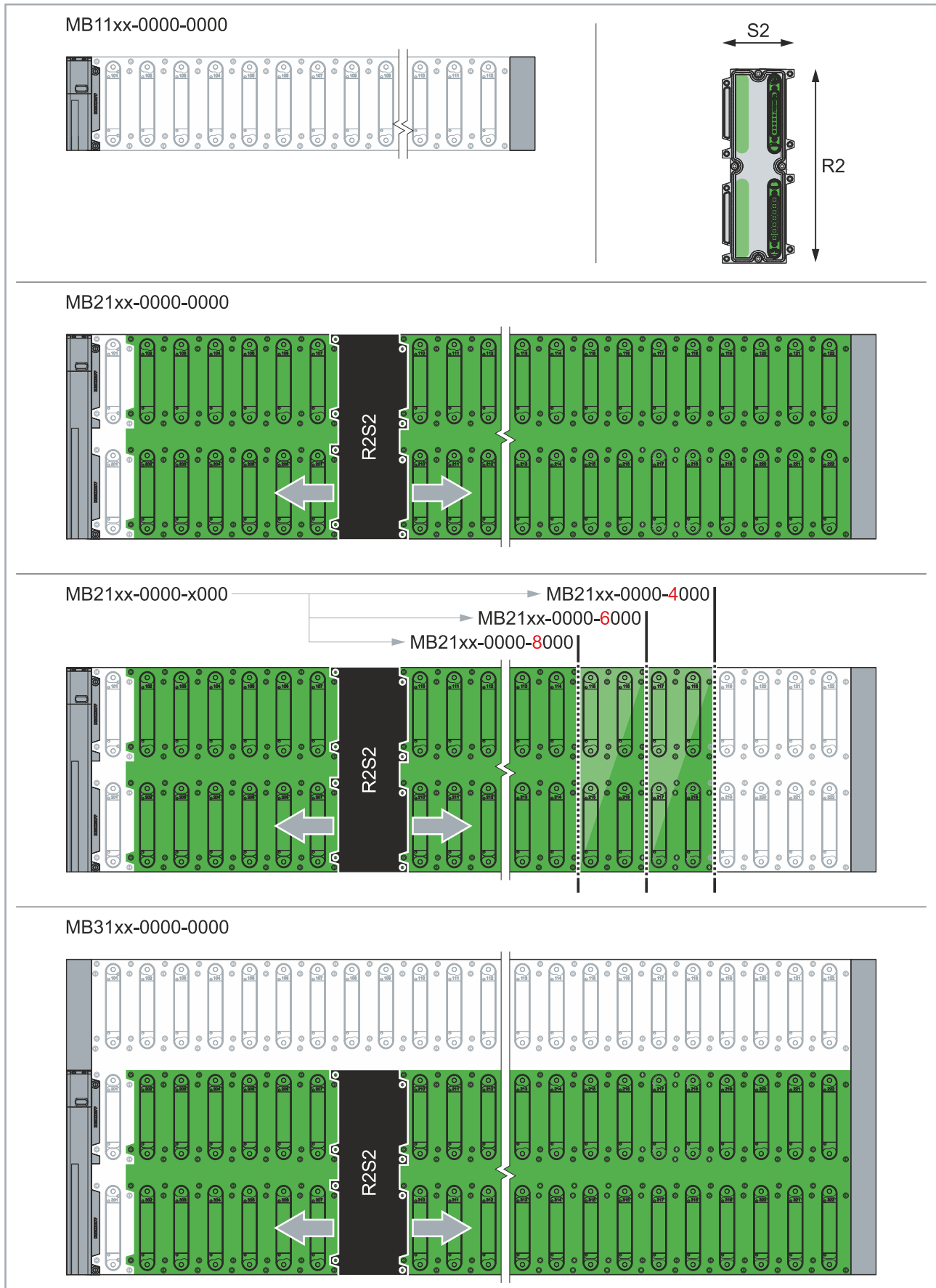

4.3 Mounting the module

⚠ CAUTION

Danger due to the high weight of an equipped baseplate

First mount the baseplate and then the modules to the baseplate. If you mount the modules on the baseplate first, the total weight of the MX-System will increase. Another person is required to transport and assemble an equipped baseplate.

- Wear personal protective equipment.
- The equipped baseplate must be transported and mounted by two people.

NOTICE

Ensure correct installation

If the module is not installed correctly, liquids and dirt may enter and damage the MX-System. The IP65/ IP67 protection rating is not met if the installation is incorrect.

NOTICE

Limited number of mating cycles

The module may be plugged in a maximum of 25 times to attach it to the baseplate. If the module is plugged into the baseplate more than 25 times, a secure connection between the module and the baseplate cannot be guaranteed.

- Observe the permissible number of mating cycles.
- Replace the module if the number of mating cycles is exceeded.
- Replace the baseplate if the number of mating cycles is exceeded.

1. Plug the module on the baseplate
2. Tighten all screws
3. Observe tightening torques:

Components	Tightening torque [Nm]
Screws	5

Further information on installation can be found in the system manual in the "Mounting" chapter.

5 Connection

NOTICE

Defect caused by hot plug

If cables are connected or disconnected during operation, damage to property is possible.

- Only connect or disconnect cables when all supply voltages have been shutdown.

5.1 Principles

Tightening torques for connectors

Use a torque wrench to tighten the M12 connectors, e.g. ZB8801 from Beckhoff.

Tighten the M12 connectors to 0.6 Nm.

Protective caps

Cover unused sockets with protective caps.

The IP67 protection rating is only guaranteed if each socket is either connected to a plug or closed with a protective cap.

5.2 Digital combi channels

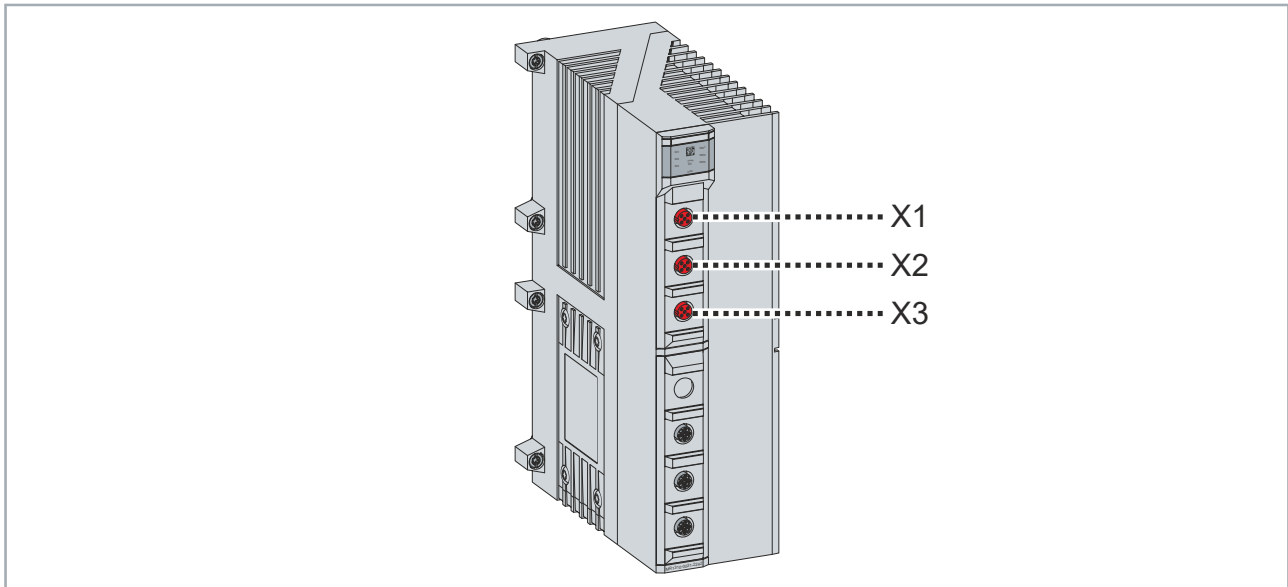

5.2.1 Required accessories

- Sensor cable with M12 connector, 4-pin
- Torque wrench for connectors

5.2.2 Pin assignment

M12 connector	Pin	Signal	Function
	1	+24 V DC	Supply voltage output 24 V DC
	2	DIO B	Digital input/output channel B
	3	GND	Ground
	4	DIO A	Digital input/output channel A
	5	n.c.	--

5.2.3 Connection diagram

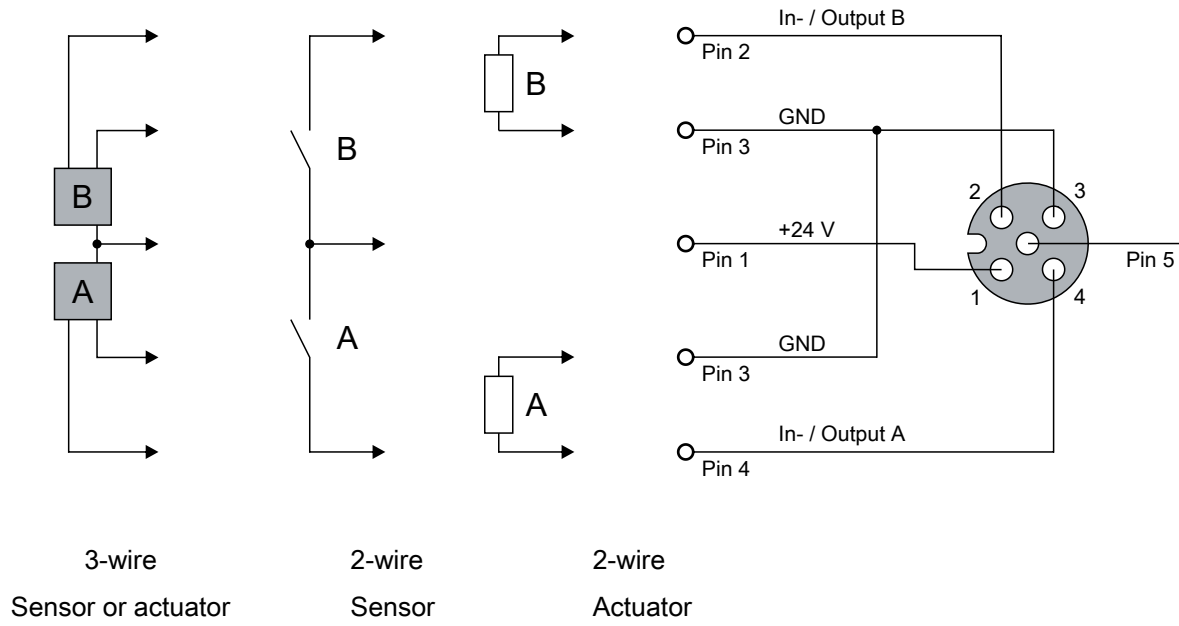

5.3 Relay outputs

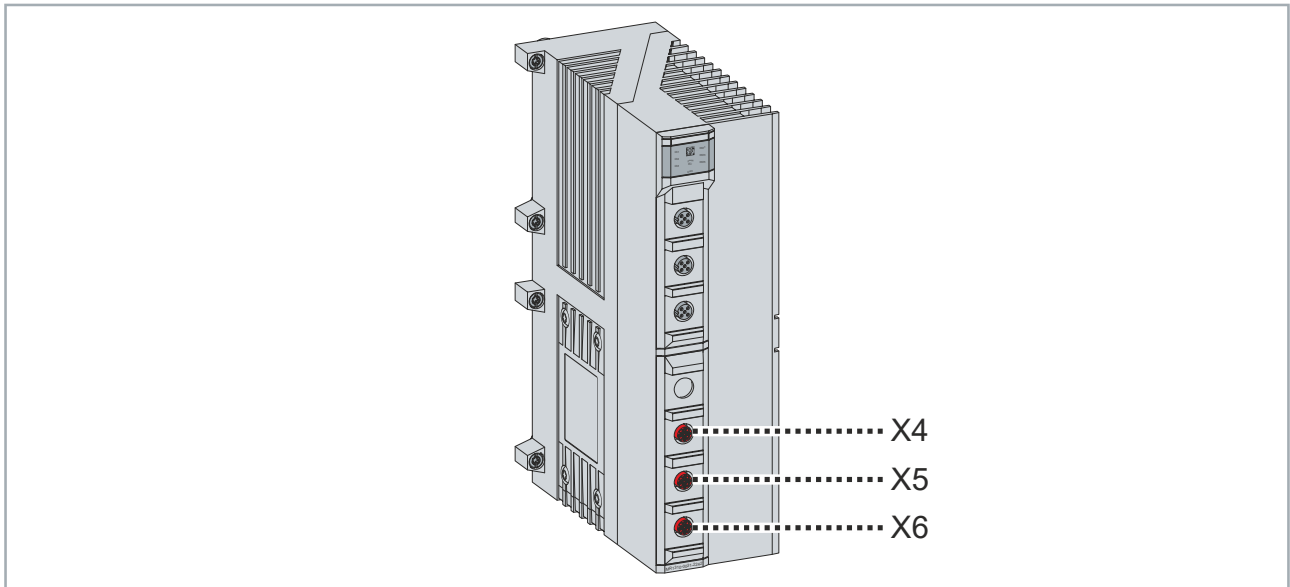

5.3.1 Required accessories

- Connection cable with S-coded M12 connector
- Torque wrench for connectors

5.3.2 Pin assignment

M12 connector	Pin	X4	X5	X6
	1	L1	L2	L3
	2	n.c.	n.c.	n.c.
	3	N	N	N
	4	PE	PE	PE

6 Commissioning and operation

⚠ WARNING

Danger to life due to electric shock

After switching on, a life-threatening voltage may be present at open connectors.

- Before switching on, make sure that all components supplied with power voltage are fully and properly installed and correctly wired.
- Before switching on, ensure that unused connectors and other connections are covered with the sealing caps, dummy caps or protective caps provided for this purpose.

NOTICE

Damage to property due to operation in an unsuitable environment

Before commissioning, ensure that the environmental conditions at the place of commissioning and operation are complied with at all times.

1. Plug the module into a baseplate.
2. Screw the module onto the baseplate.
3. Wire the module.
4. Switch on the external supply voltage.

6.1 During operation

6.1.1 Replacing the fuses

⚠ WARNING

Danger to Life from Electric Shock

Death or serious injury can occur.

- Apply the five safety rules of electrical engineering before changing a fuse.

The fuses are located behind the fuse cover on the side of the module.

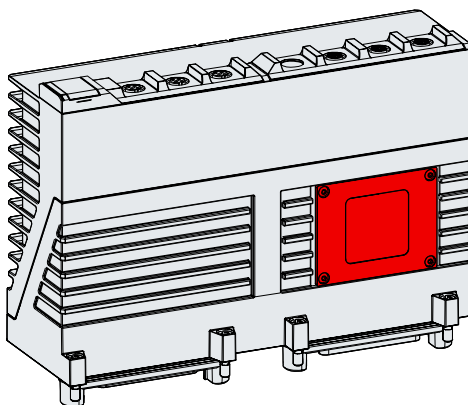

Proceed as follows to replace a fuse:



Required tools

- Torx T25 screwdriver
- Torque wrench 5 Nm
- Pliers



Required replacement fuses with the following specifications

- Rated current: 16 A
- Rated voltage: 600 V AC
- Characteristics: gRL
- Dimensions: 10.3 x 38 mm
- Type examples: SIBA 60 034 34.16

1. Loosen all mounting screws of the module
2. Take the module off the baseplate

For more information, refer to the system manual in the chapter "Disassembly".

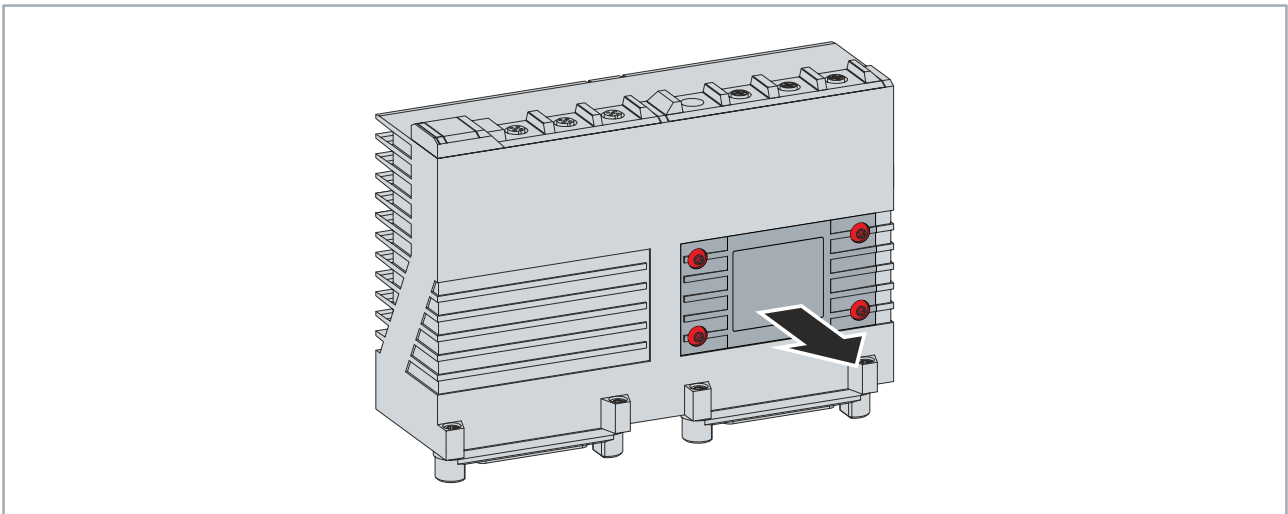

3. Remove the screws
4. Remove the safety flap

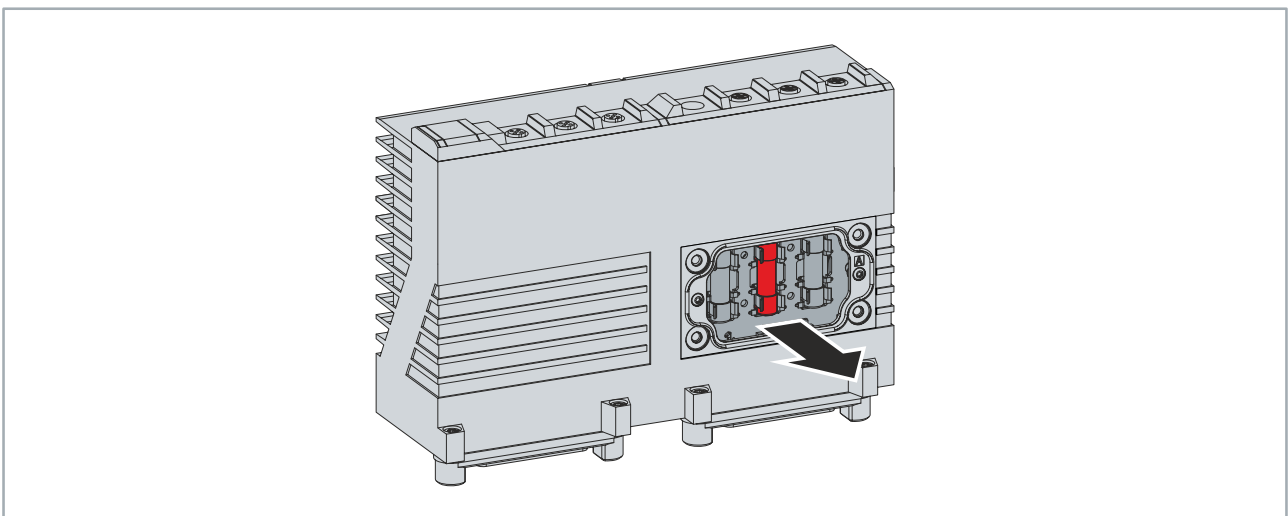

5. Remove old fuses with pliers

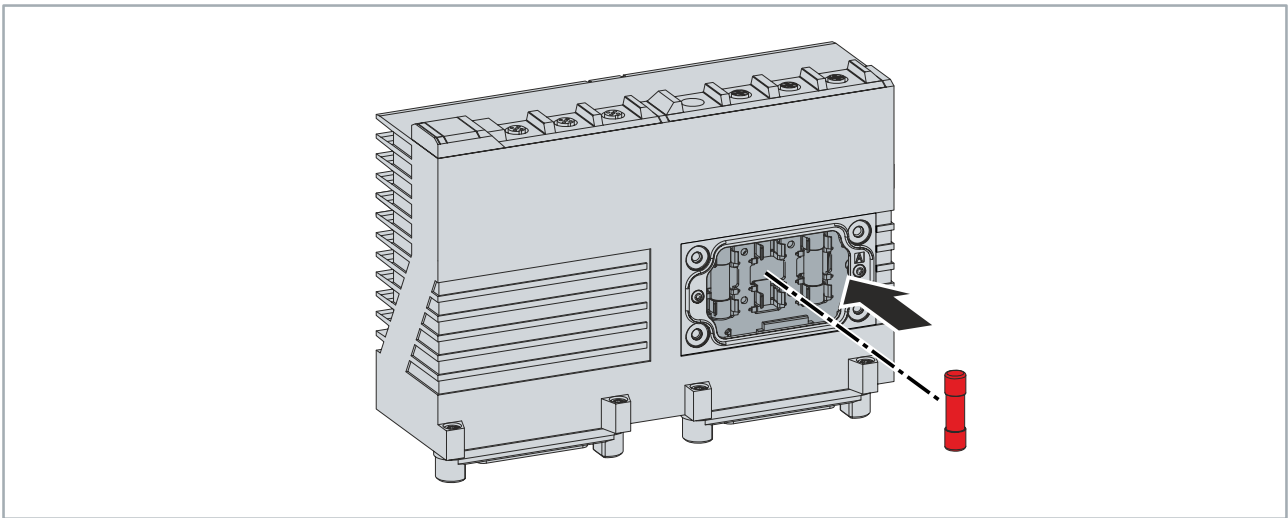

6. Insert new fuses by hand

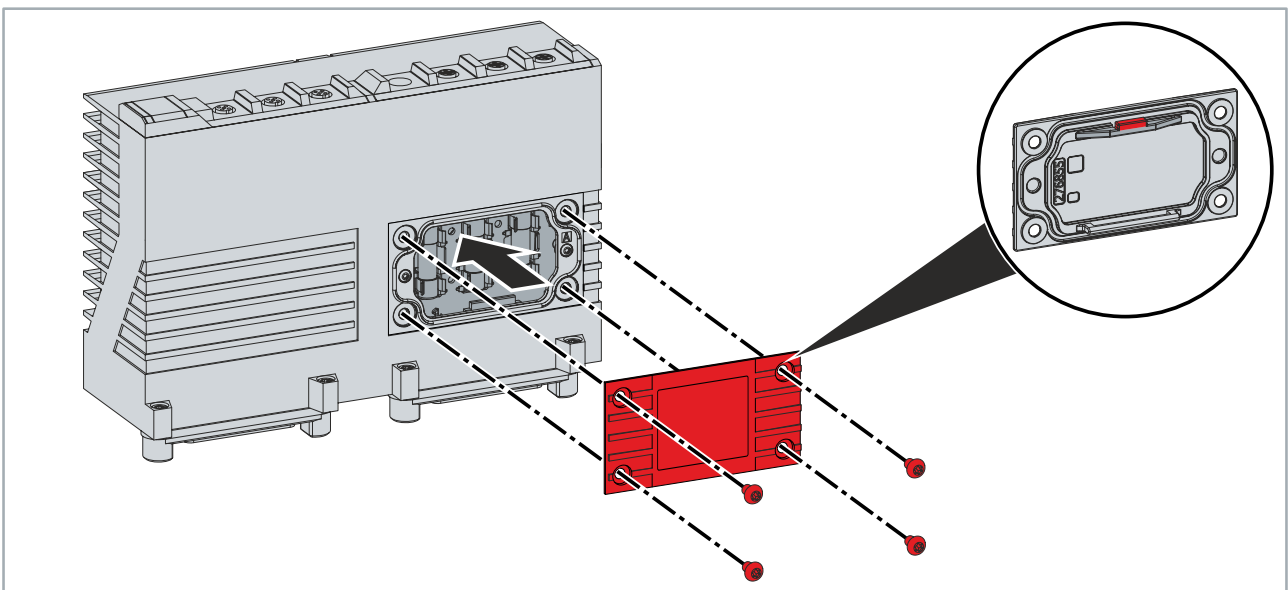

7. Insert the safety flap with the latching lug facing upwards

8. Insert and tighten the screws

9. Observe tightening torques:

Components	Tightening torque [Nm]
Screws	5

7 Software functions

Software functions are the functions of a module's firmware that a controller can access via EtherCAT.

Functionality

The following descriptions document the full range of software functions at the time of publication of this manual. The range of functions that can actually be used depends on the firmware version of a module.

7.1 Digital input

This software function enables the configuration, control and diagnosis of a digital input integrated in the module.

It is implemented by the EtherCAT profile 5001.00101 "Digital Input single input presentation", or "DIP" for short.

7.1.1 Process Data Objects (PDO)

DIP Input

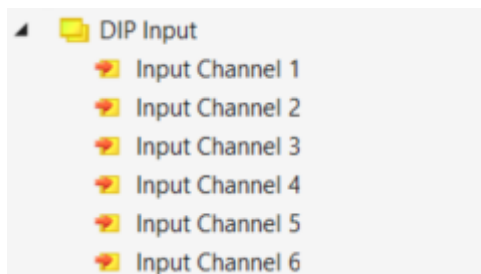

DIP Diagnosis

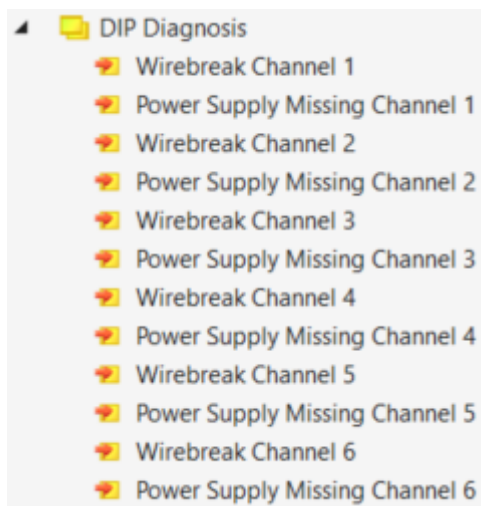

7.2 Digital output

This software function enables the configuration, control and diagnosis of a digital output integrated in the module.

It is implemented by the EtherCAT profile 5001.00201 "Digital Output single output presentation", or "DOS" for short.

7.2.1 Process Data Objects (PDO)

DOS Output

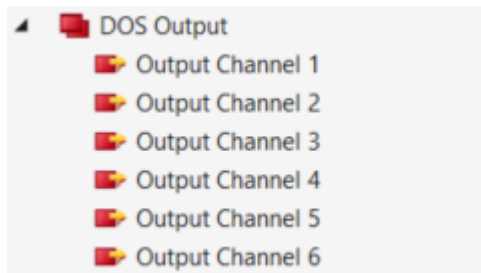

DOS Diagnosis

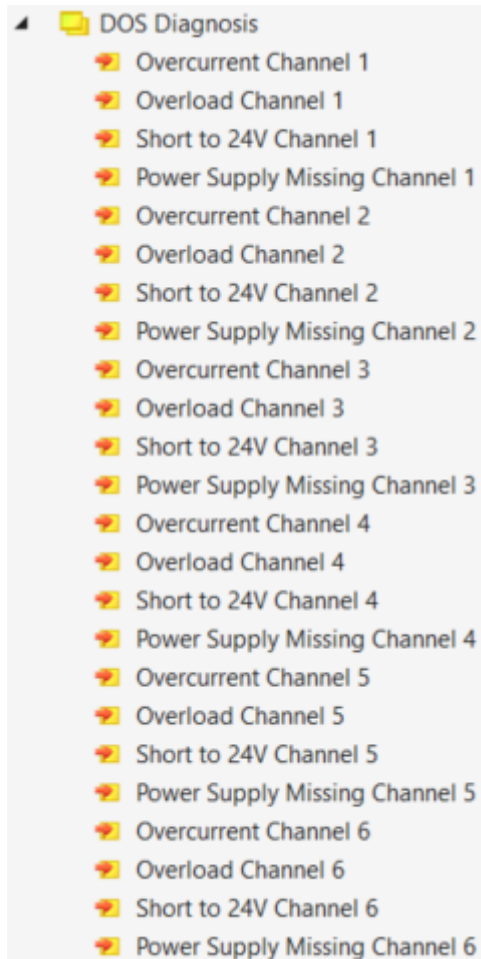

7.3 Process data object EFU Inputs

EFU Inputs

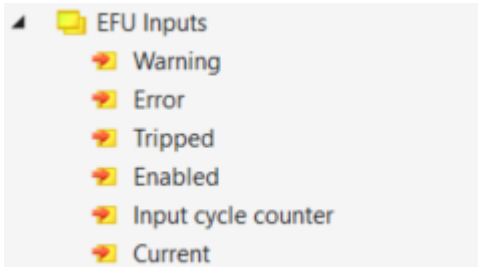

7.4 Process data object EFU Outputs

EFU Outputs

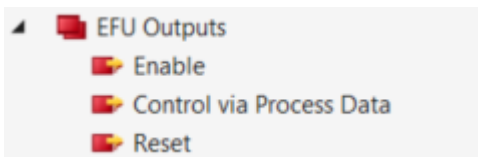

7.5 Relay output

This software function enables the configuration, control and diagnosis of a relay output integrated in the module.

It is implemented by the EtherCAT profile 5001.00205 "Relay Profile", or "RELAY" for short.

7.5.1 Process Data Objects (PDO)

RELAY L1/L2/L3 Inputs

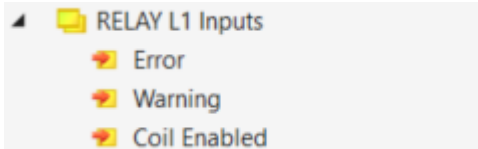

RELAY L1/L2/L3 Outputs

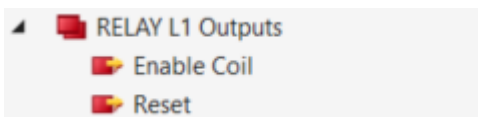

RELAY Device Inputs

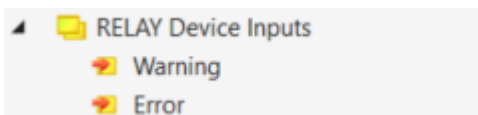

RELAY Device Outputs

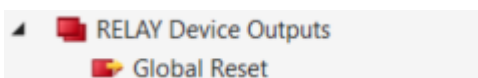

8 Decommissioning

8.1 Disassembly

WARNING

Danger to life due to electric shock

After disconnecting from the supply voltage, a life-threatening voltage is still present at the contacts of the DC link voltage. Touching the contacts can lead to death or injury from electric shock.

- After disconnecting from the supply network, wait 10 minutes before starting disassembly.

Disassembly may only be carried out by qualified and trained technical personnel.

- ✓ The supply voltage is shut down.
 - 1. Remove cables.
 - 2. Loosen all mounting screws of the module.
 - 3. Take the module off the baseplate.
- ⇒ The module has been removed correctly.

8.2 Disposal



Products marked with a crossed-out wheeled bin shall not be discarded with the normal waste stream. The device is considered as waste electrical and electronic equipment. The national regulations for the disposal of waste electrical and electronic equipment must be observed.

9 Appendix

9.1 CoE parameters

See parameter list in the Beckhoff Information System: [Link](#)

9.2 Manual version history

The following table shows the version history of this manual.

Version	Comment
1.0	• First release

9.3 Support and Service

Beckhoff and their partners around the world offer comprehensive support and service, making available fast and competent assistance with all questions related to Beckhoff products and system solutions.

Download finder

Our [download finder](#) contains all the files that we offer you for downloading. You will find application reports, technical documentation, technical drawings, configuration files and much more.

The downloads are available in various formats.

Beckhoff's branch offices and representatives

Please contact your Beckhoff branch office or representative for [local support and service](#) on Beckhoff products!

The addresses of Beckhoff's branch offices and representatives round the world can be found on our internet page: www.beckhoff.com

You will also find further documentation for Beckhoff components there.

Beckhoff Support

Support offers you comprehensive technical assistance, helping you not only with the application of individual Beckhoff products, but also with other, wide-ranging services:

- support
- design, programming and commissioning of complex automation systems
- and extensive training program for Beckhoff system components

Hotline: +49 5246 963-157
e-mail: support@beckhoff.com

Beckhoff Service

The Beckhoff Service Center supports you in all matters of after-sales service:

- on-site service
- repair service
- spare parts service
- hotline service

Hotline: +49 5246 963-460
e-mail: service@beckhoff.com

Beckhoff Headquarters

Beckhoff Automation GmbH & Co. KG

Huelshorstweg 20
33415 Verl
Germany

Phone: +49 5246 963-0
e-mail: info@beckhoff.com
web: www.beckhoff.com

9.4 Accessories

Suitable accessories can be found on the product website:

<https://www.beckhoff.com/mr1310-0031-2242>

Product	Description
ZMX1000-0010	M5x17.5 combi-TX25 replacement screws for module fastening (PU = 10 pcs.)
ZMX4001-0001	Replacement cover for potential equalization for 1-row baseplate with Beckhoff logo
ZMX4001-0002	Replacement cover for potential equalization for 2- and 3-row baseplate with Beckhoff logo

The following items are also available for replacing worn parts:

MX seal S2R2

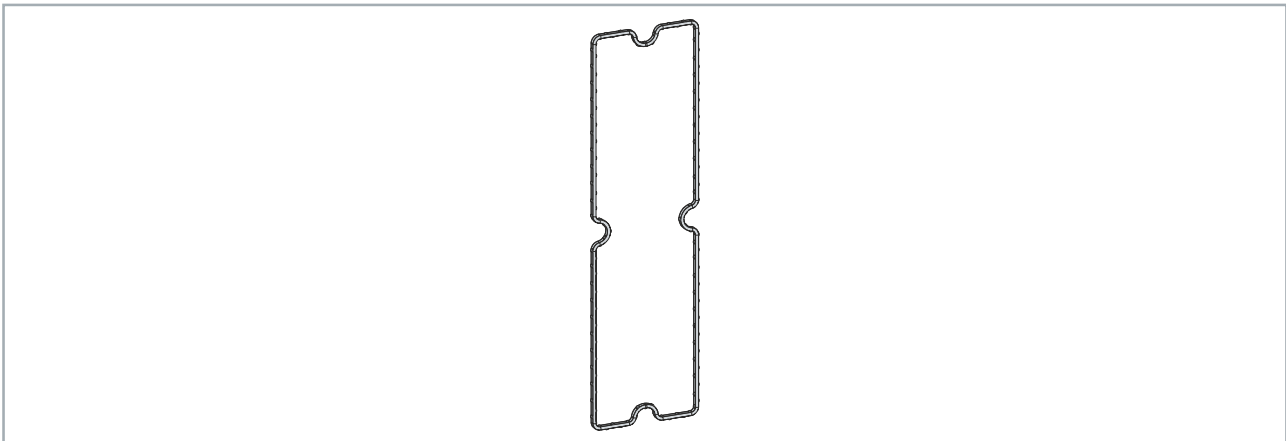

The S2R2 seal is available to replace worn and damaged seals on a 2-row MX module with two slots.

Trademark statements

Beckhoff®, ATRO®, EtherCAT®, EtherCAT G®, EtherCAT G10®, EtherCAT P®, MX-System®, Safety over EtherCAT®, TC/BSD®, TwinCAT®, TwinCAT/BSD®, TwinSAFE®, XFC®, XPlanar® and XTS® are registered and licensed trademarks of Beckhoff Automation GmbH.

More Information:

www.beckhoff.com/mr1310-0031-2242

Beckhoff Automation GmbH & Co. KG
Hülshorstweg 20
33415 Verl
Germany
Phone: +49 5246 9630
info@beckhoff.com
www.beckhoff.com

