

Manual | EN

MD6020-0003-2345

DC link power supply, 600 V DC/20 A, external braking resistor, B23

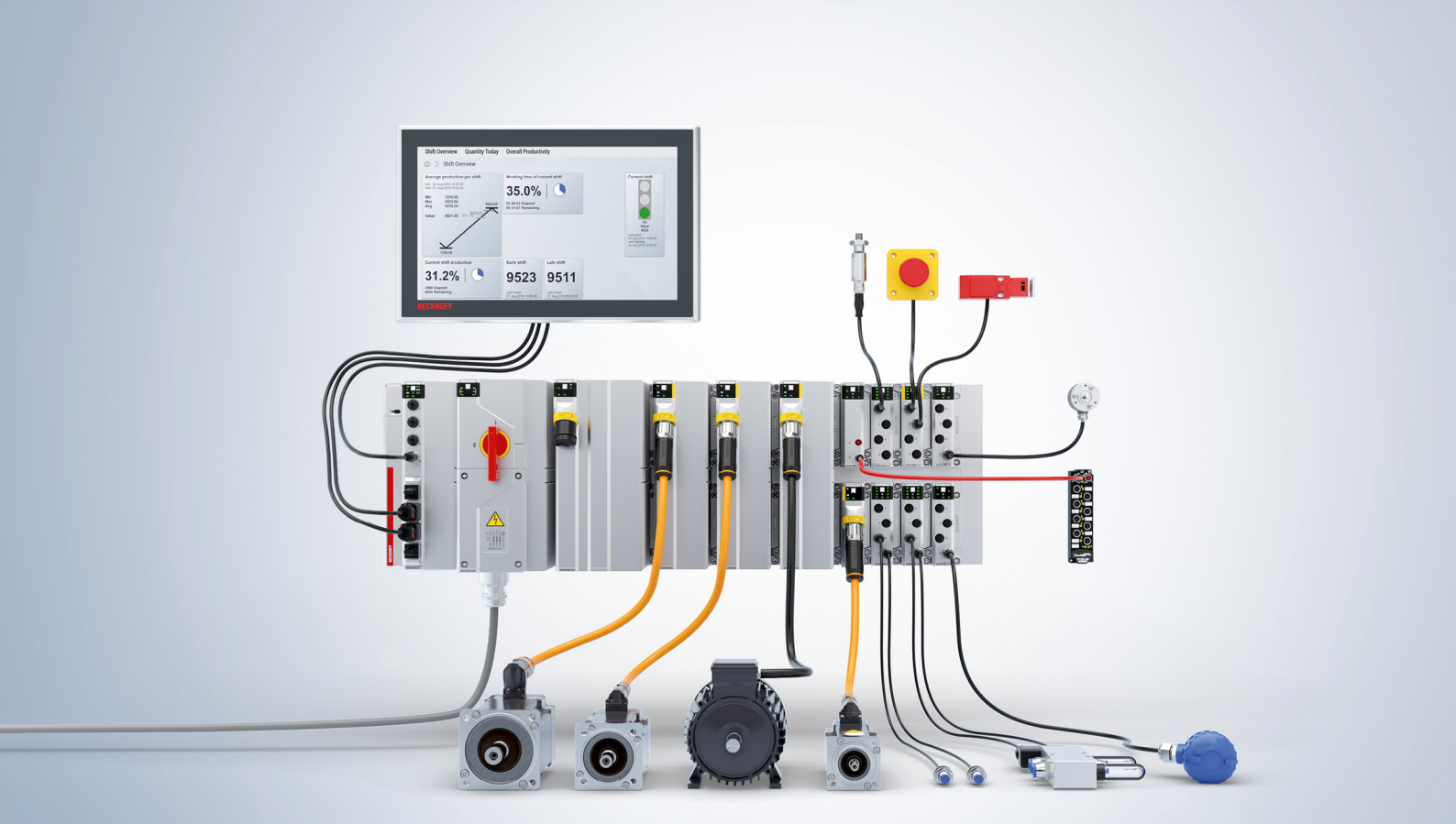

Table of contents

1 Foreword	5
1.1 Notes on the documentation	5
1.2 For your safety	6
1.3 Intended use	7
1.3.1 Improper use	7
1.4 Safety instructions	8
1.4.1 Before operation	8
1.4.2 During operation	8
1.4.3 After operation	8
1.5 Safety sign	9
2 Product overview	10
2.1 Name plate	12
2.2 Product functions	13
2.3 Delivery state	14
2.3.2 Breaking resistor	14
2.4 Block diagram	15
2.5 Type key	16
2.6 Status display	17
2.7 Dimensions	18
3 Technical data	19
3.1 Data for operation and environment	19
3.2 System data	19
3.3 Electrical data	21
3.4 Residual current circuit breaker	21
4 Mechanical installation	22
4.1 Preparation	22
4.2 Placement of the module on the baseplate	23
4.3 Mounting the module	24
5 Connection	25
6 Commissioning and operation	26
6.1 Requirements	26
6.1.2 Forming the capacitors	27
6.2 Commissioning	27
6.3 During operation	27
7 Decommissioning	28
7.1 Disassembly	28
7.2 Disposal	28
8 Standards and guidelines	29
9 Appendix	30
9.1 Manual version history	30
9.2 Support and Service	31
9.3 Accessories	32

1 Foreword

1.1 Notes on the documentation

This description is intended exclusively for trained specialists in control and automation technology who are familiar with the applicable national standards.

The documentation and the following notes and explanations must be complied with when installing and commissioning the components.

The trained specialists must always use the current valid documentation.

The trained specialists must ensure that the application and use of the products described is in line with all safety requirements, including all relevant laws, regulations, guidelines, and standards.

Disclaimer

The documentation has been compiled with care. The products described are, however, constantly under development.

We reserve the right to revise and change the documentation at any time and without notice.

Claims to modify products that have already been supplied may not be made on the basis of the data, diagrams, and descriptions in this documentation.

Trademarks

Beckhoff®, ATRO®, EtherCAT®, EtherCAT G®, EtherCAT G10®, EtherCAT P®, MX-System®, Safety over EtherCAT®, TC/BSD®, TwinCAT®, TwinCAT/BSD®, TwinSAFE®, XFC®, XPlanar®, and XTS® are registered and licensed trademarks of Beckhoff Automation GmbH.

If third parties make use of the designations or trademarks contained in this publication for their own purposes, this could infringe upon the rights of the owners of the said designations.

EtherCAT 

EtherCAT® is a registered trademark and patented technology, licensed by Beckhoff Automation GmbH, Germany.

Copyright

© Beckhoff Automation GmbH & Co. KG, Germany.

The distribution and reproduction of this document, as well as the use and communication of its contents without express authorization, are prohibited.

Offenders will be held liable for the payment of damages. All rights reserved in the event that a patent, utility model, or design are registered.

Third-party trademarks

Trademarks of third parties may be used in this documentation. You can find the trademark notices here: <https://www.beckhoff.com/trademarks>.

1.2 For your safety

Safety regulations

Read the following explanations for your safety.

Always observe and follow product-specific safety instructions, which you may find at the appropriate places in this document.

Exclusion of liability

All the components are supplied in particular hardware and software configurations which are appropriate for the application. Modifications to hardware or software configurations other than those described in the documentation are not permitted, and nullify the liability of Beckhoff Automation GmbH & Co. KG.

Personnel qualification

This description is only intended for trained specialists in control, automation, and drive technology who are familiar with the applicable national standards.

Signal words

The signal words used in the documentation are classified below. In order to prevent injury and damage to persons and property, read and follow the safety and warning notices.

Personal injury warnings

DANGER

Hazard with high risk of death or serious injury.

WARNING

Hazard with medium risk of death or serious injury.

CAUTION

There is a low-risk hazard that could result in medium or minor injury.

Warning of damage to property or environment

NOTICE

The environment, equipment, or data may be damaged.

Information on handling the product



This information includes, for example:
recommendations for action, assistance or further information on the product.

1.3 Intended use

The module may only be installed on the mounted baseplate in electrical systems or machines and may only be put into operation as an integrated component of the system or machine. Single use of the module is not permitted.

The module is part of a multi-axis system and provides the DC link of a drive system. It is fed from an MS1xxx power supply unit. Only use the module in combination with an MS1xxx power supply unit or other suitable components of the MX-System. No other type of feed-in is permitted.

The DC link power supplies of the MD60xx series may only be operated for the purposes as defined in this documentation and under the specified ambient conditions.

The DC link power supplies of the MD60xx series may only be used with the AX2090-BW65-xxxx braking resistors provided for this purpose.



Read the entire drive system documentation:

- These operating instructions
 - The operating instructions for the accessories used
 - All relevant system documentation for the MX-System
 - The machine manufacturer's complete documentation for the machine
-

Intended use of an MX-System

Application in machines and systems in industrial environments and exclusively inside buildings.

The electrical wiring must be permanent wiring.

Improper use

Improper use is not permitted and will result in the exclusion of liability on the part of Beckhoff Automation GmbH & Co.

1.3.1 Improper use

Any type of use that exceeds the permissible values from the technical data is regarded as inappropriate and is thus prohibited.

The modules are not suitable for use in the following areas:

- Operation as a single device without integration into an overall MX system
- ATEX zones without suitable housing
- Areas with aggressive environments, for example aggressive gases or chemicals

The relevant standards and directives for EMC interference emissions must be complied with in residential areas.

1.4 Safety instructions

1.4.1 Before operation

Protective equipment

Do not remove or bypass any protective devices. Check all protective devices before operation. Make sure that all emergency switches are present at all times and can be reached by you and other people. People could be seriously or fatally injured by unprotected machine parts.

Observe tightening torques

Mount and repeatedly check connections and components, complying with the prescribed tightening torques.

Correctly ground electrical components or modules

Prevent electric shocks due to incorrect grounding of electrical components or modules. Ground all conductive components according to the specifications in the chapter [Electrical installation](#) [▶ 25].

Keep the immediate environment clean

Keep your workplace and the surrounding area clean. Ensure safe working.

Shut down and secure the machine or plant

Shut down the machine or plant. Secure the machine or plant against being inadvertently started up.

1.4.2 During operation

Do not touch hot surfaces

Check the temperature of the surfaces with a thermometer. Do not touch the components during and immediately after operation. Allow the components to cool sufficiently after switching off.

Avoid overheating

Operate the components according to the technical specifications. Refer here to the chapter Technical data. Provide for sufficient cooling. Switch the components off immediately if the temperature is too high.

1.4.3 After operation

De-energize and switch off components before working on them

Check the functionality of all safety-relevant devices. Secure the working environment. Secure the machine or plant against being inadvertently started up. Observe the chapter Decommissioning.

1.5 Safety sign

You will find safety symbols on Beckhoff products and packaging. The symbols may be glued, printed, or lasered on and may vary depending on the product. They serve to protect people and to prevent damage to the products. Safety pictograms may not be removed and must be legible for the user.

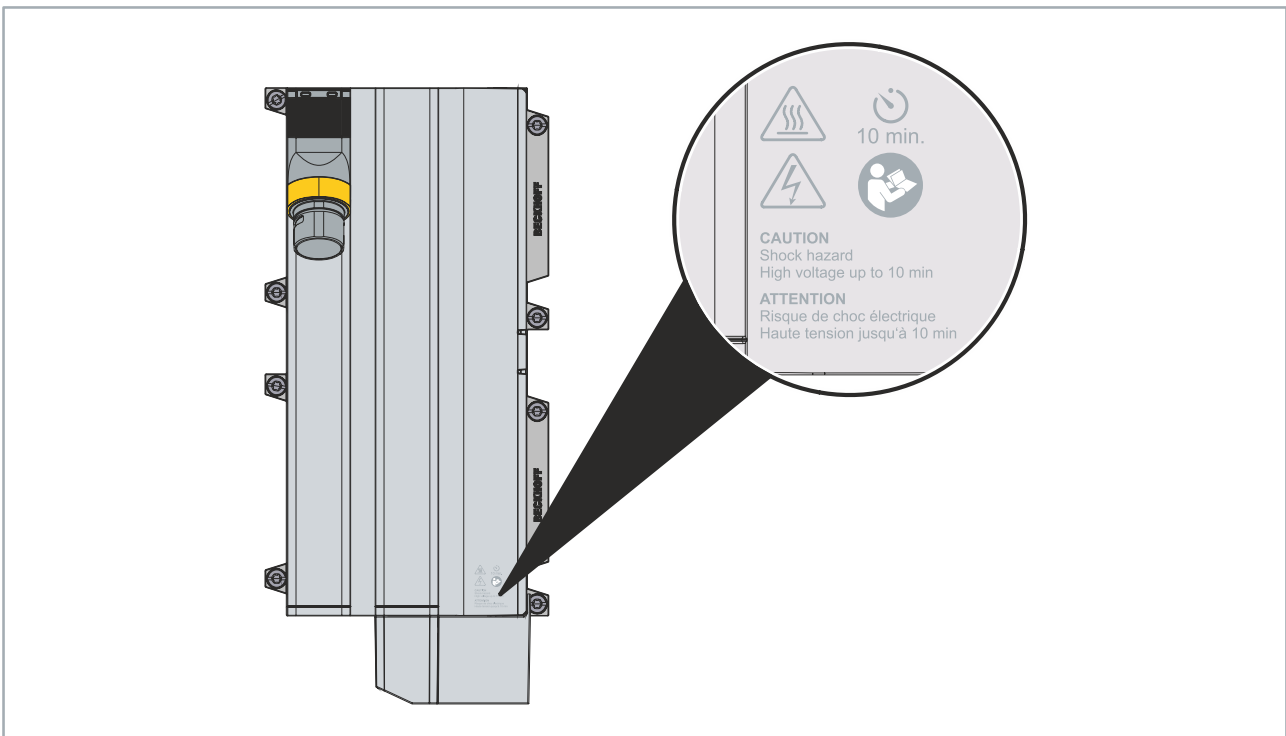

Do not touch hot surfaces!

Check the temperature of the surface with a thermometer. Do not touch the components during and immediately after operation. Allow the components to cool sufficiently after switching off.



Warning of high voltage!

The DC link capacitors and power contacts on all modules may carry hazardous voltages up to 848 V_{DC}.



10 min.

Observe the waiting time!

Dangerous voltages for 10 minutes after switching off all power connections.



Read the operating instructions!

Familiarize yourself with the entire contents of the operating instructions before commissioning. Always read the general safety instructions and the warnings in the individual chapters.

2 Product overview

The MD6xxx series DC link power supplies generate up to 730 V DC link voltage for the servo drives (MD8xxx) and variable frequency drives (MD3xxx) connected to the baseplate. Connection to an external braking resistor is possible via a B23 connector.

Front view

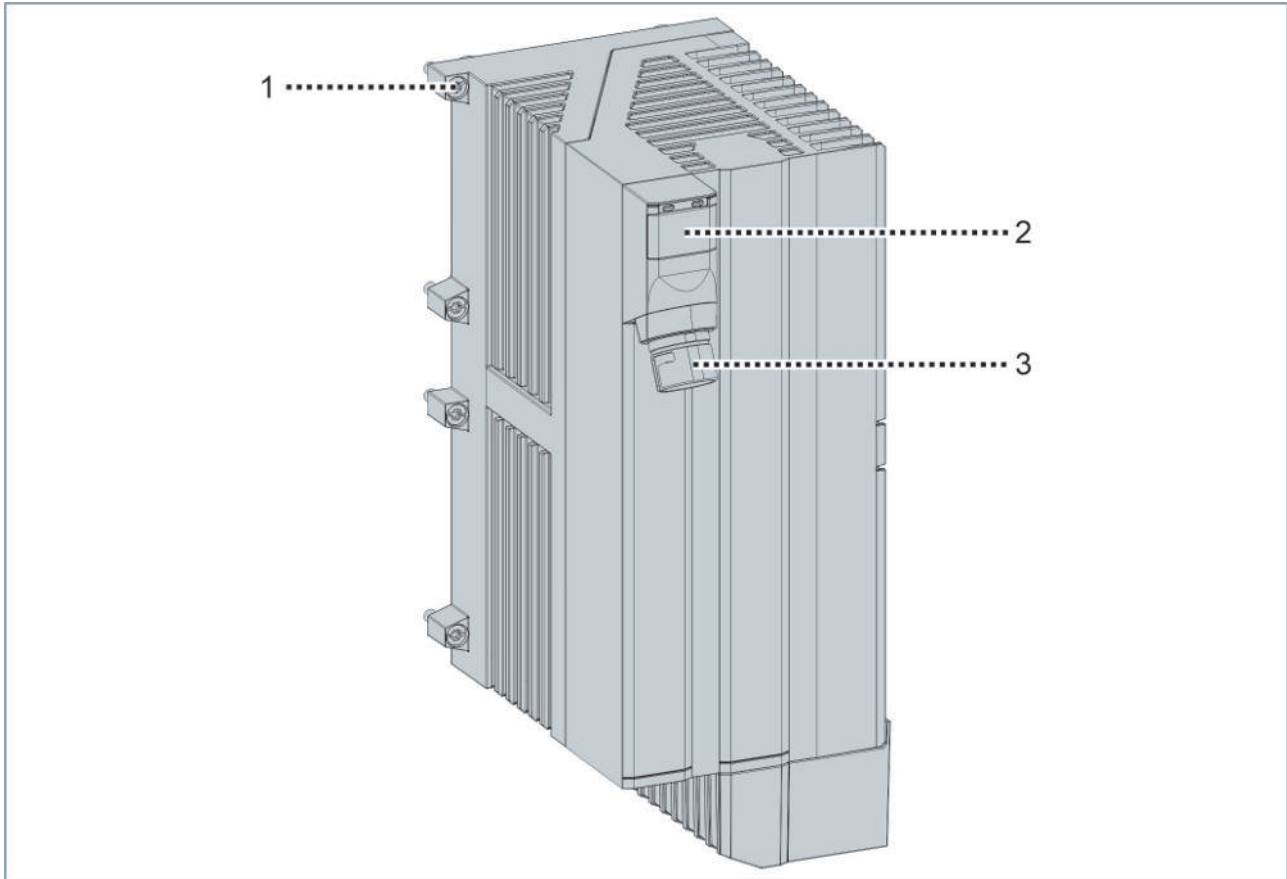

Position	Description	Further information
1	Fastening screw	
2	Status display	Status display [► 17]
3	Connection braking resistor	Connection [► 25]

Optional accessories

- External braking resistor AX2090-BW65-xxxx with protection rating IP65

Rear view

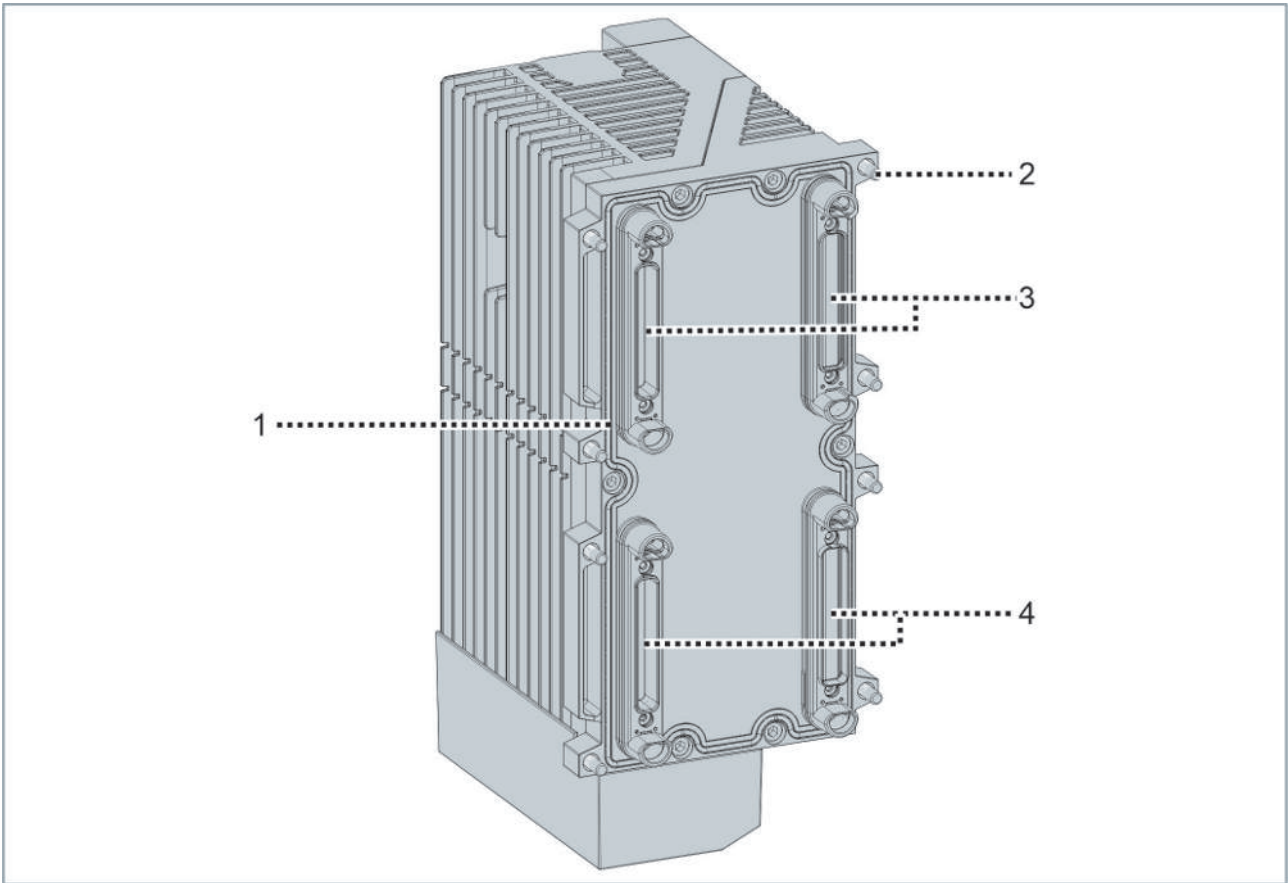

Position	Description	Further information
1	Seal	
2	Fastening screw	
3	Data connector	
4	Power supply connector	

2.1 Name plate



Position	Explanation
1	Product name
2	Order number
3	Beckhoff Traceability Number
4	Input values: voltage, current, frequency
5	Output values: voltage and current at max. ambient temperature
6	Contact details
7	Product address
8	Safety pictogram: Read operating instructions
9	Disposal according to WEEE directives
10	Safety pictogram: Caution
11	Data Matrix Code
12	UL approval
13	CE approval

2.2 Product functions

Filtering the mains voltage to comply with EMC

- Reduction of electromagnetic interference
- Avoidance of disturbances on the grid
- Compliance with standards and regulations
- Protection of connected devices

Generation of the DC link voltage by rectifying the AC mains voltage

- Enables energy exchange between MD modules
- Improving the efficiency and flexibility of the electrical system

Integrated charging current limitation

- Protection of the components
- Avoidance of mains voltage sags
- Reduction of electromagnetic interference
- Increased system reliability
- Smooth start-up

Storing energy in the DC link

- Smoothing and stabilizing current consumption and providing a consistent power supply
- Provision of peak performance that can be called up quickly, e.g. when starting motors
- Efficient energy use to minimize losses and efficient energy conversion in systems with variable loads or regenerative brakes
- Energy storage for regenerative braking
- Short-term grid independence in the event of voltage drops or short-term grid interruptions

Integrated control of the external braking resistor

- Connection of the braking resistor to prevent overvoltage shutdown in the event of DC link voltage peaks

2.3 Delivery state

This chapter describes the default settings for basic product functions on delivery.

2.3.1 DC link power supply

When delivered, the DC link power supply is automatically switched on when the power infeed is in operation.

The power LED flashes green until the DC link is fully charged.

Power LED lights up continuously when charging the DC link is complete.

Ready LED lights up green when all mains phases are present and the amplitude of the mains voltage and the mains frequency are within tolerance.

2.3.2 Braking resistor

On delivery, no braking resistor is connected or configured or parameterized in the software.

2.4 Block diagram

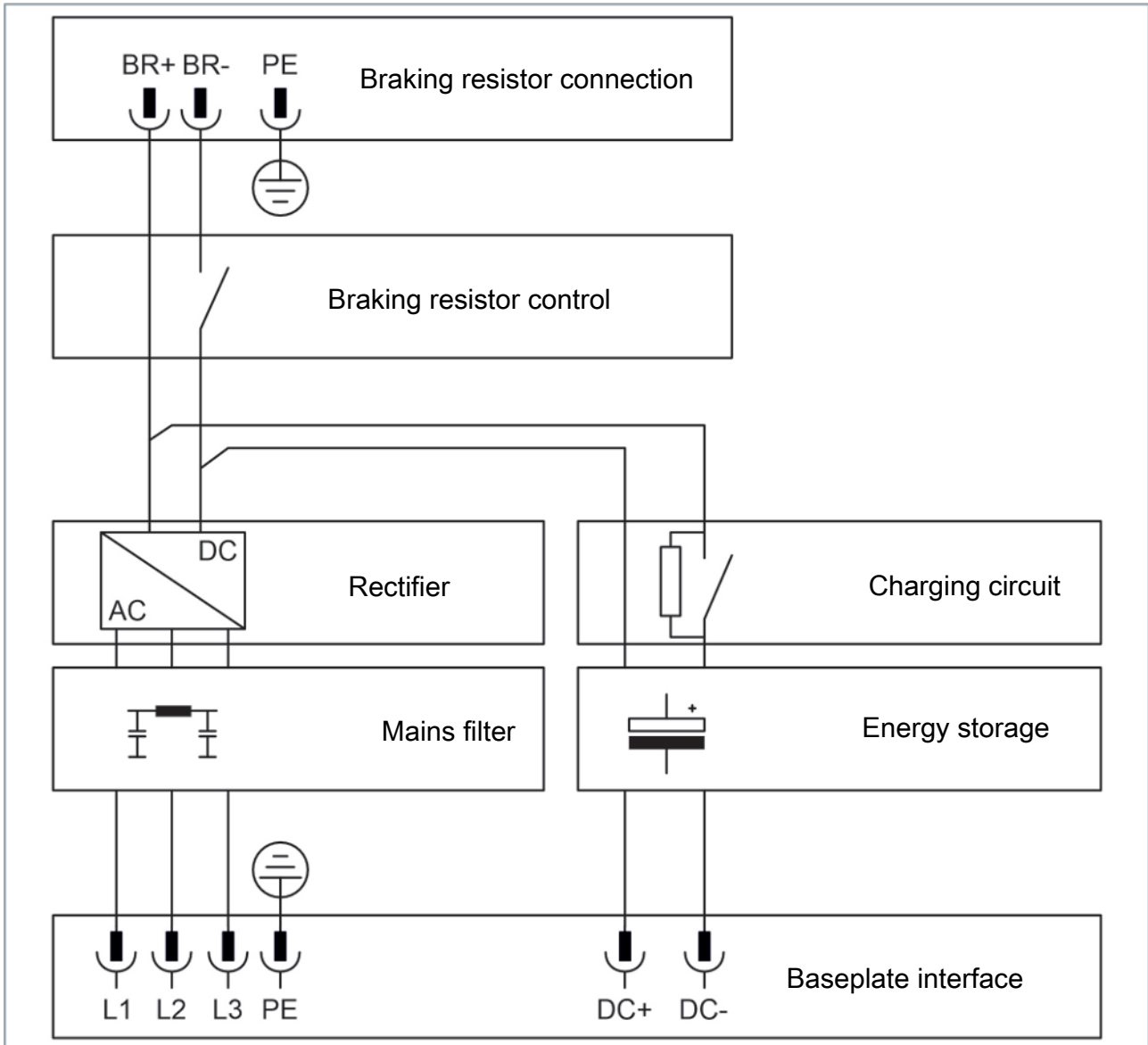

2.5 Type key

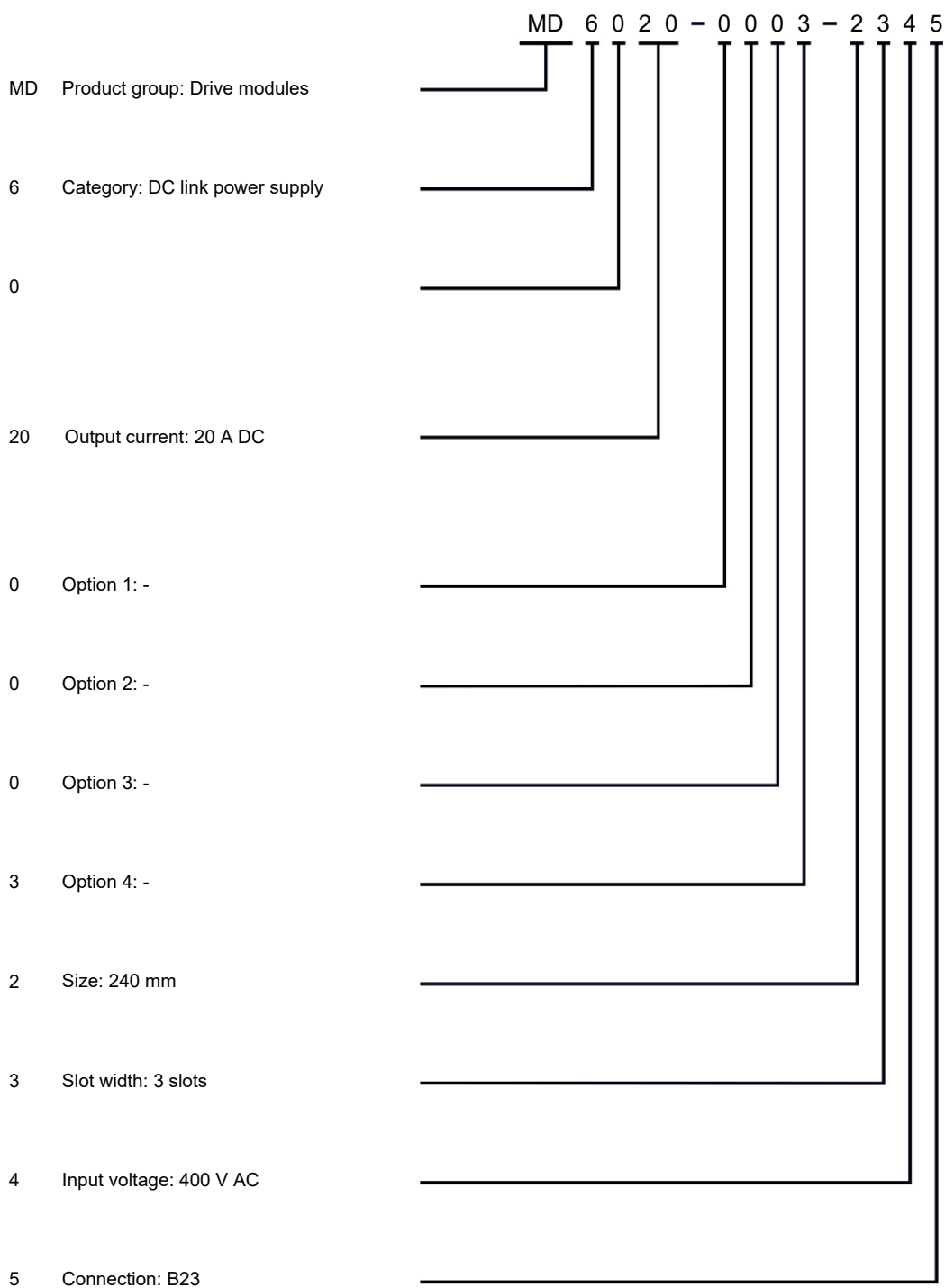

2.6 Status display

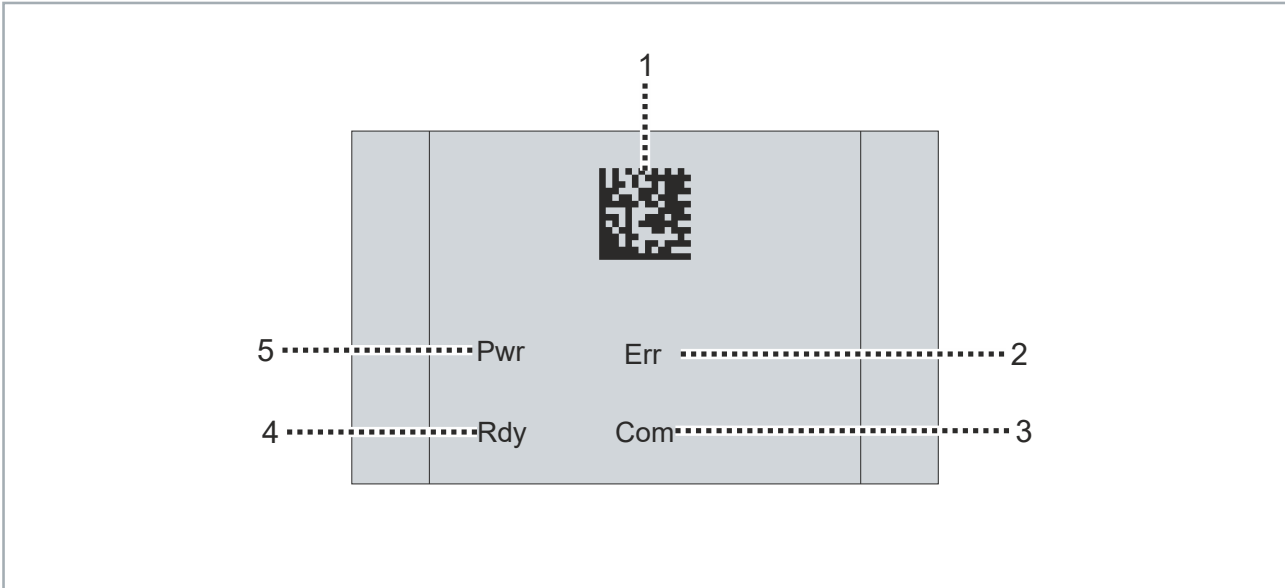
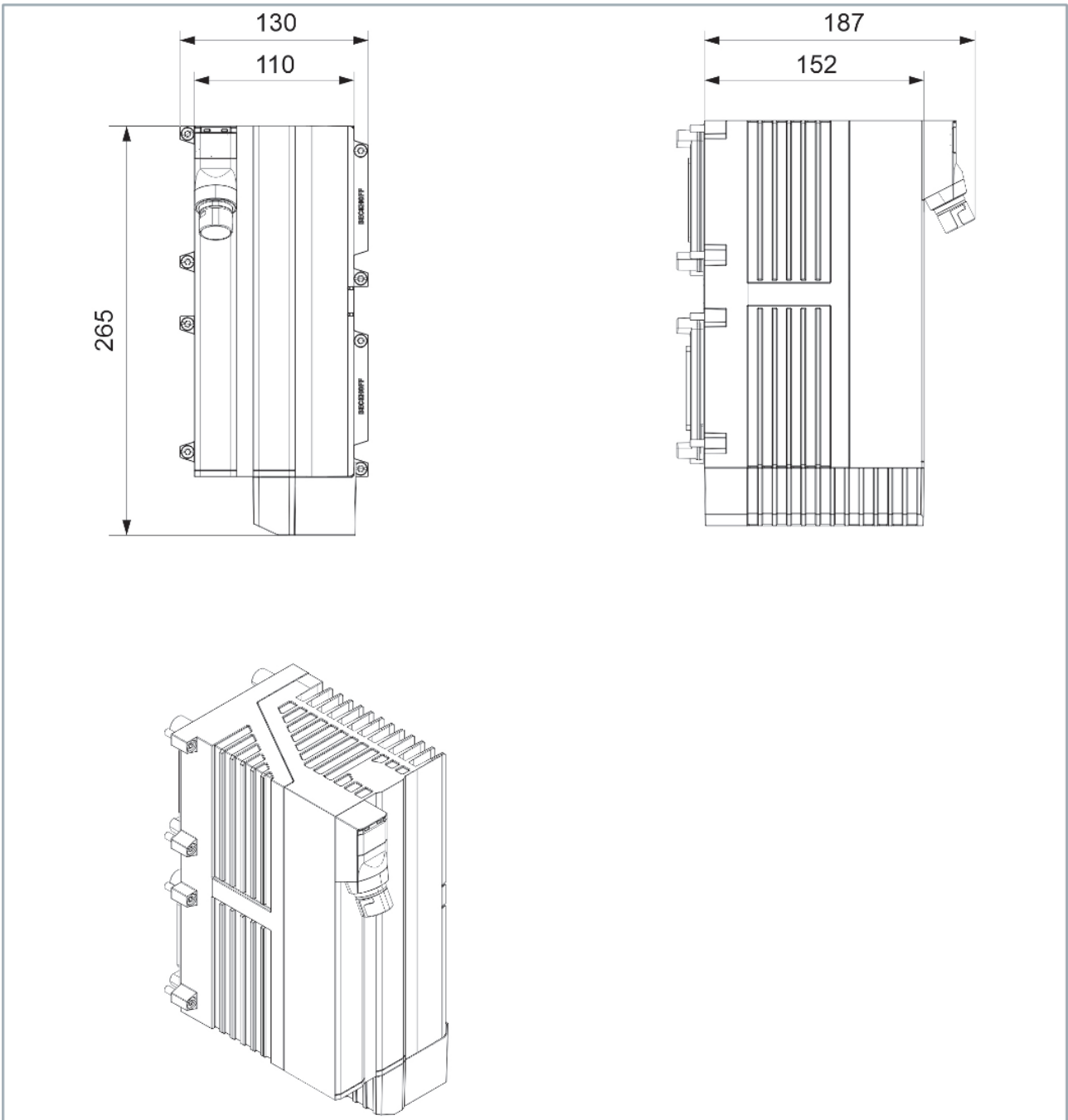

Fig. 1: MD6020-0003-2345 status display

Position	Labeling	Meaning	Status	Explanation
1	-	-	-	Beckhoff Identification Code as DataMatrix code
2	Com	Communication		Displays the status of communication to the baseplate. See system manual "Status display"
3	Rdy	Ready	Lights up green permanently	<ul style="list-style-type: none"> All mains phases available Amplitude of mains voltage and mains frequency is within tolerance
4	Err	Error	Lights up red permanently	There is a fault, e.g. overtemperature, overvoltage
5	Pwr	Power	Lights up green permanently	DC link is charged
			Flashing green	DC link is charging
			Off	DC link voltage below 60 V DC

2.7 Dimensions

All dimensions in mm



3 Technical data

All values are typical values over the entire temperature range, unless stated otherwise.

3.1 Data for operation and environment

Beckhoff products are designed for operation under certain environmental conditions, which vary according to the product. The following specifications must be observed for operation and environment in order to achieve the optimum service life of the products.

Environmental conditions	
Operating temperature	0...50 °C
Storage temperature	-25...+60 °C
Air humidity	95%, no condensation
Protection rating	IP20 as a separate module IP65 as part of a fully and correctly assembled MX-System with fan cartridge IP65/IP67 as part of a fully and correctly assembled MX-System without fan cartridge
Degree of pollution	2
Overvoltage category	III 300 V
Maximum installation altitude	2000 m

3.2 System data

Housing data	
Rows (height)	2
Slots (width)	3
Dimensions W × H × D	110 mm x 240 mm x 152 mm without connectors
Material	Zinc and aluminum die-cast
Cooling	Convection
Depth with connector	220 mm
Weight	4.9 kg
Installation position	Vertical. See system manual, chapter "Installation conditions".

Baseplate interface	
Connector	1 data connector 1 power connector
Hot Swap	No

General technical data	
Product group	Drive modules
Category/Execution	DC link power supply
DC link voltage	0...700 V DC*
Output current	20 A
Connection for external braking resistor	yes
Braking resistor Connection technology	B23 connector
Number of connectable MD9xxx capacitor modules	1
Cable lengths	Total motor cable length: <ul style="list-style-type: none"> • 20 m per motor • 200 m per drive system

*) Modules are capable of operating at maximum dc link working voltage of temporarily 848 Vdc.

3.3 Electrical data

Mains supply		
Rated input current	[A AC]	17.5
Rated supply voltage	[V AC]	3 x 200 _{-25%} ...480 ^{+8%} V AC
Permissible voltage phase (L) against earth (PE)	[V AC]	300
System voltage and peripheral voltage	[V DC]	24
Current consumption 24 V DC	[mA]	40
SCCR value	[kA]	65
Mains filter		integrated, category C2

Rated output power		
At 400 V AC supply voltage	[kW]	10.7

DC link		
Voltage range	[V DC]	0...700*
Capacitance	[μF]	780
Rated output current at 20 °C ambient temperature without fan cartridge	[A DC]	20
Rated output current at 40 °C ambient temperature without fan cartridge	[A DC]	15
Rated output current at 40 °C ambient temperature with fan cartridge	[A DC]	20
Rated output current at 50 °C ambient temperature with fan cartridge	[A DC]	15
Maximum peak output current for max. 5 s	[A DC]	40

*) Modules are capable of operating at maximum dc link working voltage of temporarily 848 Vdc.

External braking resistor - Values dependent on the connected resistor		
Continuous braking power	[kW]	1.6
Maximum braking power	[kW]	21.8
Minimum braking resistor	[Ω]	33

3.4 Residual current circuit breaker

Power supply modules with a built-in mains filter may exhibit a small leakage current due to the capacitors in the filter. This error current may cause malfunctions of standard residual current circuit breakers. Therefore, use all-current sensitive residual current circuit breakers type B, which also take into account DC current. Beckhoff recommends residual current circuit breakers with start-up delay.

4 Mechanical installation



Required tools

- Torx T25 screwdriver
- Torque wrench 5 Nm

4.1 Preparation

NOTICE

Check the module for damage

If the seal is worn or damaged, liquids and dirt can penetrate and damage the MX-System. The IP65/IP67 protection rating is not met if the seals are worn or damaged.

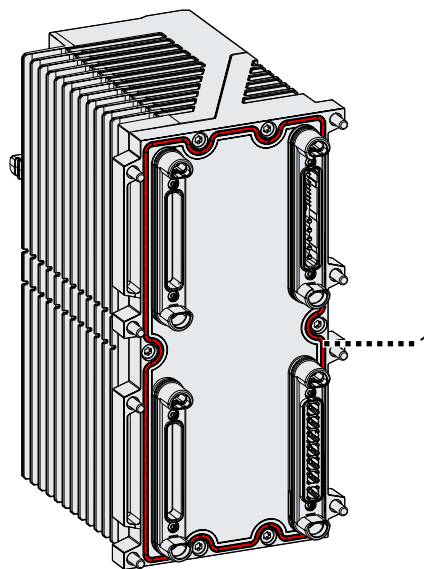

1. Check the seal [1] of the module for wear and damage
2. Replace worn and damaged seals

4.2 Placement of the module on the baseplate

The module can be plugged into the following areas marked in green:



4.3 Mounting the module

⚠ CAUTION

Danger due to the high weight of an equipped baseplate

First mount the baseplate and then the modules to the baseplate. If you mount the modules on the baseplate first, the total weight of the MX-System will increase. Another person is required to transport and assemble an equipped baseplate.

- Wear personal protective equipment.
- The equipped baseplate must be transported and mounted by two people.

NOTICE

Ensure correct installation

If the module is not installed correctly, liquids and dirt may enter and damage the MX-System. The IP65/IP67 protection rating is not met if the installation is incorrect.

NOTICE

Limited number of mating cycles

The module may be plugged in a maximum of 25 times to attach it to the baseplate. If the module is plugged into the baseplate more than 25 times, a secure connection between the module and the baseplate cannot be guaranteed.

- Observe the permissible number of mating cycles.
- Replace the module if the number of mating cycles is exceeded.
- Replace the baseplate if the number of mating cycles is exceeded.

Observe the mounting sequence on the baseplate!

1. MD60xx DC link power supply
 2. Optional capacitor module MD9000
 3. All other axis modules such as MD8xxx servo drives and MD3xxx variable frequency drives
1. Plug the module on the baseplate
 2. Tighten all screws
 3. Observe tightening torques:

Components	Tightening torque [Nm]
Screws	5

Further information on installation can be found in the system manual in the "Mounting" chapter.

5 Connection

Observe the GND concept described in the system manual.

Checking the performance data

1. Check the assignment of the power infeed and DC link power supply.
2. Ensure that the requirements for the supply network (tolerance band of the voltage range and phase to earth voltage) are met by the power infeed and the DC link power supply.

Checking the drive design in Motion Designer

1. Check that the DC link power supply is not overloaded by the connected servo drive.
2. Check whether the braking resistor is suitably dimensioned for your application.

Connection of the external braking resistor

- Connection for an external braking resistor with B23 plug: X1
- Coding 2

Pin assignment

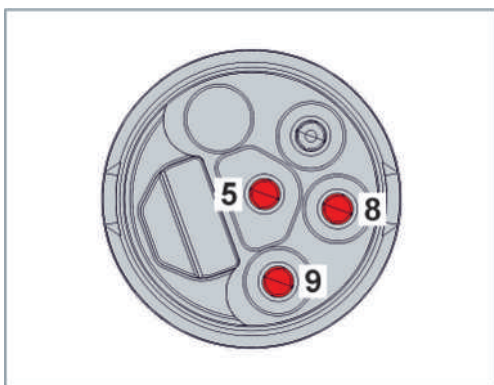

Terminal point	Connection
5	PE
8	RB+
9	RB-

6 Commissioning and operation

⚠ WARNING

Serious injuries due to residual voltage

Although a motor is no longer rotating, voltage on the control and power connections or a residual voltage in the capacitors of the DC link power supply can lead to serious injuries.

- Remove all relevant mains fuses
- Switch off the main switch on the power infeed
- Secure the main switch of the power infeed against being switched on again
- Wait at least 10 minutes after switching off the main switch until the DC link voltage has been discharged before starting work.

6.1 Requirements

- Components show no signs of damage
- Screw connections of the components are correctly tightened
- Wiring and cables are installed correctly

NOTICE

Limited functionality due to unformed capacitors

The dielectric in the DC link capacitors decreases over a very long storage period and the capacitors lose their forming. This can lead to considerable functional restrictions and even a shortened service life of the device.

- If the storage period exceeds 5 years, [form the capacitors](#) [► 27]

Pay attention to the following points before commissioning:

1. Make sure that an emergency stop switch complying with the valid regulations is fitted to the control station
2. Check components for damage
3. Check that the modules are correctly seated on the baseplate and on the machine
4. Tighten screw connections correctly
5. Mount mechanical and electrical protective devices
6. Check the wiring, connection and proper grounding

6.1.1 Drivetrain

The application, servo drives, motors and gear units must be matched to one another so that sufficient safety is ensured for all components. Mechanical stiffness can occur after a while due to wear.

Make sure that the components in the working area of the system have adequate reserves so that the working life is not impaired and the necessary control quality can be maintained.

The Beckhoff software "[TE5910 | TwinCAT 3 Motion Designer](#)" is available for configuration of the drivetrain and selection of suitable components.

6.1.2 Forming the capacitors

During long storage periods, the installed DC link capacitors must be reformed. The following steps must be carried out:

1. Connecting the mains voltage to the drive system
2. Leave the drive system connected to the mains voltage for 60 minutes and do not operate under load

The device can then be used as usual.

The time interval at which the capacitors must be formed varies depending on the storage temperature.

Storage temperature	Forming interval
< 25 °C	5 years
> 25 °C	3 years

6.2 Commissioning



Exemplary commissioning

The procedure for commissioning is described as an example. A different method may be appropriate or necessary, depending on the application of the components.

NOTICE

The supply voltage activates the power supply

As soon as the external supply voltage is applied, the 24 V power supply of the power infeed is automatically active and outputs $U_B = 24 \text{ V DC}$ to the baseplate. This behavior cannot be set.

- Switch on the external supply voltage
- Parameterize the module functions with the TwinCAT Drive Manager 2 (TE5950) if necessary

6.3 During operation

- Observe information for environment and operation
- Observe maintenance intervals
- Switch off the system if
 - unusual noise occurs
 - smoke develops
 - an atypical temperature development occurs

Pay attention to the following points during operation:

1. Atypical noise development
2. Smoke development
3. Always check drive surfaces and cables for dirt or dust
4. Check temperature development
5. Check function of safety devices

7 Decommissioning

7.1 Disassembly

⚠ WARNING

Danger to life due to electric shock

After disconnecting from the supply voltage, a life-threatening voltage is still present at the contacts of the DC link voltage. Touching the contacts can lead to death or injury from electric shock.

- After disconnecting from the supply network, wait 10 minutes before starting disassembly.

⚠ CAUTION

Danger to life due to exposed contacts with dangerous voltages

After disassembling the module, the contacts of the power connectors in the baseplate are exposed. Touching the contacts can lead to death or injury from electric shock.

- Shutdown the input voltage before disassembly.
- Switch off the main switch on the power infeed
- Secure the main switch of the power infeed against being switched on again
- Wait at least 10 minutes after switching off the main switch until the DC link voltage has been discharged before starting work.

Further information on this can be found in the chapter in the system manual at Disassembly.

Disassembly may only be carried out by qualified and trained technical personnel.

- ✓ The supply voltage is shut down.
1. Remove cables.
 2. Loosen all mounting screws of the module.
 3. Take the module off the baseplate.
- ⇒ The module has been removed correctly.

7.2 Disposal



Products marked with a crossed-out wheeled bin shall not be discarded with the normal waste stream. The device is considered as waste electrical and electronic equipment. The national regulations for the disposal of waste electrical and electronic equipment must be observed.

8 Standards and guidelines

Standards

Generic standards EN IEC 61000-6-2

"Immunity standard for industrial environments"

Generic standards EN IEC 61000-6-4

"Emission standard for industrial environments"

IEC 61800-5-3

"Adjustable speed electrical power drive systems"

Part 5-3: Safety requirements - Functional, electrical and environmental requirements for encoders

Product standard EN IEC 61800-3

"Adjustable speed electrical power drive systems. EMC requirements and specific test methods"

EN IEC 63000

"Technical documentation for the assessment of electrical and electronic products with respect to the restriction of hazardous substances"

Guidelines

2014/30/EU

EMC Directive

2014/35/EU

Low Voltage Directive

2011/65/EU

RoHS Directive

9 Appendix

9.1 Manual version history

The following table shows the version history of this manual.

Version	Comment
1.0.0	<ul style="list-style-type: none">• First release

9.2 Support and Service

Beckhoff and their partners around the world offer comprehensive support and service, making available fast and competent assistance with all questions related to Beckhoff products and system solutions.

Download finder

Our [download finder](#) contains all the files that we offer you for downloading. You will find application reports, technical documentation, technical drawings, configuration files and much more.

The downloads are available in various formats.

Beckhoff's branch offices and representatives

Please contact your Beckhoff branch office or representative for [local support and service](#) on Beckhoff products!

The addresses of Beckhoff's branch offices and representatives round the world can be found on our internet page: www.beckhoff.com

You will also find further documentation for Beckhoff components there.

Beckhoff Support

Support offers you comprehensive technical assistance, helping you not only with the application of individual Beckhoff products, but also with other, wide-ranging services:

- support
- design, programming and commissioning of complex automation systems
- and extensive training program for Beckhoff system components

Hotline: +49 5246 963-157
e-mail: support@beckhoff.com

Beckhoff Service

The Beckhoff Service Center supports you in all matters of after-sales service:

- on-site service
- repair service
- spare parts service
- hotline service

Hotline: +49 5246 963-460
e-mail: service@beckhoff.com

Beckhoff Headquarters

Beckhoff Automation GmbH & Co. KG

Huelshorstweg 20
33415 Verl
Germany

Phone: +49 5246 963-0
e-mail: info@beckhoff.com
web: www.beckhoff.com

9.3 Accessories

Suitable accessories can be found on the product website:

- <https://www.beckhoff.com/md6020-0003-2345>

Product	Description
ZMX1000-0010	M5x17.5 combi-TX25 replacement screws for module fastening (PU = 10 pcs.)

AX2090-BW65-xxxx braking resistor

When braking a drive, the energy generated is converted into heat by the braking resistors from the AX2090-BW65 series. As components with the protection rating IP65, the braking resistors feature full contact hazard protection and are protected against dust or water jets from any direction.

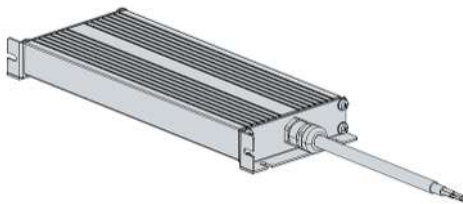

For further information, read the original operating instructions for the braking resistors from the AX2090-BW65-xxxx series.

The following items are also available for replacing worn parts:

MX seal S3R2

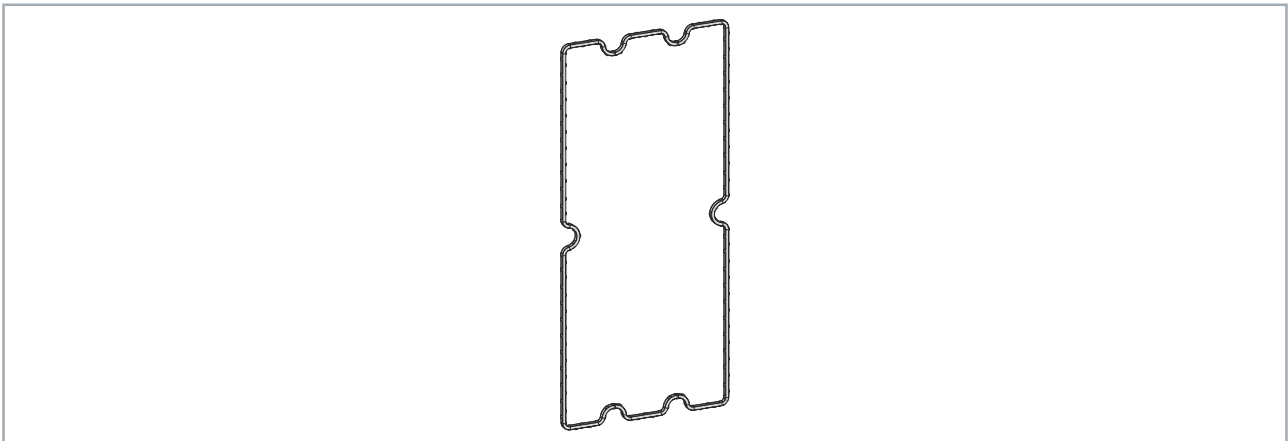

The S3R2 seal is available to replace worn and damaged seals on a 2-row MX module with three slots.

Trademark statements

Beckhoff®, ATRO®, EtherCAT®, EtherCAT G®, EtherCAT G10®, EtherCAT P®, MX-System®, Safety over EtherCAT®, TC/BSD®, TwinCAT®, TwinCAT/BSD®, TwinSAFE®, XFC®, XPlanar® and XTS® are registered and licensed trademarks of Beckhoff Automation GmbH.

More Information:

www.beckhoff.com/md6020-0003-2345

Beckhoff Automation GmbH & Co. KG
Hülshorstweg 20
33415 Verl
Germany
Phone: +49 5246 9630
info@beckhoff.com
www.beckhoff.com

