

Documentation | EN

# PS9401-2420-0000

Redundancy Module 12 - 28 V DC, 20 A





# Table of contents

<b>1 Overview .....</b>	<b>5</b>
<b>2 Foreword .....</b>	<b>6</b>
2.1 Notes on the documentation .....	6
2.2 Safety instructions .....	7
2.3 Terminology and abbreviations .....	10
<b>3 Technical data, mounting, wiring .....</b>	<b>11</b>
3.1 Input and output parameters .....	11
3.2 Power loss .....	13
3.3 Functional wiring diagram .....	14
3.4 Terminals and wiring .....	14
3.5 Front side and connecting elements .....	15
3.6 Lifetime expectancy .....	16
3.7 MTBF .....	16
3.8 EMC .....	17
3.9 Environment .....	18
3.10 Safety and protective functions .....	19
3.11 Dielectric strength .....	19
3.12 Declaration of conformity and approvals .....	20
3.13 Dimensions and weight .....	21
<b>4 Application notes .....</b>	<b>22</b>
4.1 Recommendations for redundancy mode .....	22
4.2 Lateral installation distances .....	22
4.3 Application examples .....	23
4.4 Installation positions .....	24
<b>5 Appendix .....</b>	<b>25</b>
5.1 Accessories .....	25
5.2 Compatible power supplies for PS9401-2420-0000 .....	26
5.3 Documentation issue status .....	27
5.4 Support and Service .....	28



# 1 Overview

## PS9401-2420-0000 | Redundancy module 12–28 V, 20 A



- For N+1 and 1+1 redundant systems
- Dual input with single output
- Only 60 mV voltage drop with 10 A output current
- Only 0.6 W loss with 10 A
- Protection against reverse input polarity
- Full power between -40 °C and +70 °C
- Width only 32 mm
- Robust metal housing

The PS9401-2420-0000 is a redundancy module that can be used to set up 1+1 and N+1 redundant systems. It has two input channels, to which power supplies with output currents of up to 10 A can be connected, and one output that can carry nominal currents of up to 20 A. The output can also be used up to 24 A if the ambient temperature is < +45 °C.

The module is suitable for power supplies with a constant current overload behavior as well as for any type of intermittent overload behavior.

The redundancy module uses MOSFET technology instead of diodes for decoupling the two input channels. This reduces the heat development and the voltage drop between input and output.

Due to the low power loss, the device is very narrow and requires a width of just 32 mm on the DIN rail. Large connection terminals enable secure and fast installation. The redundancy module requires no additional auxiliary voltage. Due to the international approvals package, the device is suitable for virtually every application.

### Overview of technical data <sup>\*)</sup>

Overview of technical data	PS9401-2420-0000
Input voltage	DC 12-28 V (±30 %)
Input voltage range	8.4-36.4Vdc
Input current	2x 12 A, below +45 °C ambient temperature 2x 10 A, at +70 °C ambient temperature 2x 16 A, up to 5 s Linear derating between +45 °C and 70 °C
Output current	24 A, below +45 °C ambient temperature 20 A, at +70 °C ambient temperature 32 A, up to 5 s
Maximum output current below 6 Vdc	26 A rms, in every overload or short-circuit state
Voltage drop between input and output	60 mV, with 2x 5 A input 110 mV, with 2x 10 A input
Power loss	0.21 W, with no load 0.6 W, with 2x 5 A input 2.0 W, with 2x 10 A input
Temperature range	-40 °C to + 70 °C
Dimensions (W x H x D)	32 x 124 x 117 mm, without DIN rail
Weight	250 g

\*) All values typical with 24 Vdc input voltage, 20 A output current, 25 °C ambient temperature and after a running-in time of 5 minutes, unless specified otherwise.

## 2 Foreword

### 2.1 Notes on the documentation

#### Copyright

© Beckhoff Automation GmbH & Co. KG, Germany.

The reproduction, distribution and utilization of this document as well as the communication of its contents to others without express authorization are prohibited.

Offenders will be held liable for the payment of damages. All rights reserved in the event of the grant of a patent, utility model or design.

#### Disclaimer

The documentation has been prepared with care. The products described are, however, constantly under development.

We reserve the right to revise and change the documentation at any time and without prior announcement.

No claims for the modification of products that have already been supplied may be made on the basis of the data, diagrams and descriptions in this documentation.

#### Trademarks

Beckhoff®, TwinCAT®, TwinCAT/BSD®, TC/BSD®, EtherCAT®, EtherCAT G®, EtherCAT G10®, EtherCAT P®, Safety over EtherCAT®, TwinSAFE®, XFC®, XTS® and XPlanar® are registered trademarks of and licensed by Beckhoff Automation GmbH. Other designations used in this publication may be trademarks whose use by third parties for their own purposes could violate the rights of the owners.

#### Patent Pending

The EtherCAT Technology is covered, including but not limited to the following patent applications and patents: EP1590927, EP1789857, EP1456722, EP2137893, DE102015105702 with corresponding applications or registrations in various other countries.

#### Intended audience

This description is only intended for the use of trained specialists in control and automation engineering who are familiar with the applicable national standards.

It is essential that the documentation and the following notes and explanations are followed when installing and commissioning these components.

The qualified personnel is obliged to always use the currently valid documentation.

The responsible staff must ensure that the application or use of the products described satisfy all the requirements for safety, including all the relevant laws, regulations, guidelines and standards.

## 2.2 Safety instructions

### Description of instructions

In this documentation the following instructions are used.  
These instructions must be read carefully and followed without fail!

#### **DANGER**

##### **Serious risk of injury!**

Failure to follow this safety instruction directly endangers the life and health of persons.

#### **WARNING**

##### **Risk of injury!**

Failure to follow this safety instruction endangers the life and health of persons.

#### **CAUTION**

##### **Personal injuries!**

Failure to follow this safety instruction can lead to injuries to persons.

#### **NOTICE**

##### **Damage to environment/equipment or data loss**

Failure to follow this instruction can lead to environmental damage, equipment damage or data loss.



#### **Tip or pointer**

This symbol indicates information that contributes to better understanding.

### Intended use

This device is designed for installation in a housing and is intended for general professional use, for example in industrial control systems or office, communication and measuring equipment.

Do not use this power supply in installations where a malfunction could cause serious injury or danger to human life.

### Exclusion of liability

All the components are supplied in particular hardware and software configurations appropriate for the application. Modifications to hardware or software configurations other than those described in the documentation are not permitted, and nullify the liability of Beckhoff Automation GmbH & Co. KG.

### Personnel qualification

This description is only intended for trained specialists in control, automation and drive engineering who are familiar with the applicable national standards.

### Safety regulations

Please note the following safety instructions and explanations!  
Product-specific safety instructions can be found on following pages or in the areas mounting, wiring, commissioning etc.

**Safety instructions and installation requirements for the PS9401-2420-0000 Redundancy Module****⚠ DANGER****Danger of electric shock, fire, injuries, injuries resulting in death!**

- Switch off the power supply before working on the device. Provide protection against unintentional reconnection.
- Do not open, modify or repair the device.
- Avoid foreign bodies entering the housing.
- Do not use the device in damp locations or in areas where moisture or condensation is likely to occur.
- Do not touch the device when it is switched on or immediately after it has been switched off. Hot surfaces can cause burns.

**⚠ WARNING****Explosion hazard warning!**

Replacement of components may affect the suitability for this environment.

Disconnect the device only when the power supply has been switched off or if the area is known not to be dangerous.

A suitable housing must be provided for the end product that has at least protection class IP54 and meets the requirements of EN 60079-0.

**NOTICE****Instructions for use in potentially explosive atmospheres**

The device is suitable for use in environments of Class I Division 2 Groups A, B, C, D and in Group II Category 3 (Zone 2).

Classification: ATEX: EPS 11 ATEX 1 312 X, II 3G EX eC IIC T4 Gc / IECEx EPS 21.0018X.



---

**i** Further notes on installation requirements

- This device contains no parts that require maintenance. If an internal fuse trips, this is due to an internal defect.
  - If any damage or malfunction occurs during installation or operation, turn off the power supply immediately and return the device to the factory for inspection.
  - Install the device in a housing that provides protection against electrical, mechanical and fire hazards.
  - Do not ground the positive output pole, as this could prevent the redundancy in case of earth leakage. Ground the negative output pole if necessary.
  - Install the device on a DIN rail according to EN 60715, with the input terminals at the bottom of the device. Other installation positions require a reduction of the output current.
  - Make sure that the wiring is correct by complying with all local and national regulations. Use suitable copper cables designed for a minimum operating temperature of 60 °C at ambient temperatures up to +45 °C, 75 °C at ambient temperatures up to +60 °C and 90 °C at ambient temperatures up to +70 °C. Make sure that all individual wires of a strand are inside the terminal connection. Unused screw terminals should be tightened firmly.
  - The device is designed for areas with a degree of pollution 2 in controlled environments. No condensation or frost is allowed.
  - The device housing offers IP20 protection. The housing offers no protection against spilled liquids.
  - The input must be supplied from a PELV or SELV source or an "isolated secondary circuit" in order to obtain a PELV or SELV output.
  - Check the correct input polarity. The device will not work if the input voltage is reversed.
  - The device is designed as equipment of "Protection Class III" according to IEC 61140.
  - A PE connection (ground) is not required. However, it may be advantageous to connect the ground terminal of the housing to ground in order to achieve high EMI immunity.
  - The device is designed for convection cooling and does not require an external fan. Do not obstruct the air flow or cover the ventilation grilles!
  - The device is designed for altitudes of up to 5000 m (16,400 ft). The output current must be reduced above 2000 m (6560 ft).
  - Keep to the following minimum mounting distances: 40 mm at the top, 20 mm at the bottom, 5 mm on the left and right. Increase the 5 mm to 15 mm if the neighboring device is a source of heat. If the device continuously runs at less than 50%, the 5 mm distance can be reduced to zero. It is possible under certain circumstances to reduce the distances. See details in the product data sheet.
  - The maximum temperature of the ambient air is +70 °C (+158 °F). The operating temperature corresponds to the ambient air temperature and is defined 2 cm below the device.
  - The device is designed for operation in the relative humidity range between 5 % and 95 %.
-

## 2.3 Terminology and abbreviations

<b>DC 24 V</b>	A value preceded by AC or DC represents a rated voltage containing standard tolerances (normally $\pm 15\%$ ). Example: DC 12 V refers to a 12 V battery, regardless of whether it is fully charged (13.7 Vdc) or discharged (10 Vdc).
<b>24 Vdc</b>	A value with the unit (Vdc) at the end is a momentary value that contains no tolerances.
<b>1+1 redundancy</b>	Use of two identical power supply units in parallel in order to ensure continued operation after most failures of a single power supply unit. The two power supply outputs should be isolated from each other by the use of diodes or other switching devices. For example, two 10 A power supply units are required in order to achieve a redundant 10 A system.
<b>N+1 redundancy</b>	Use of three or more identical power supply units in parallel in order to ensure continued operation after most failures of a single power supply unit. All power supply outputs should be isolated from one another by the use of diodes or other switching devices. Example: Five 10 A power supply units are required in an N+1 redundant system in order to achieve a 40 A redundant system.

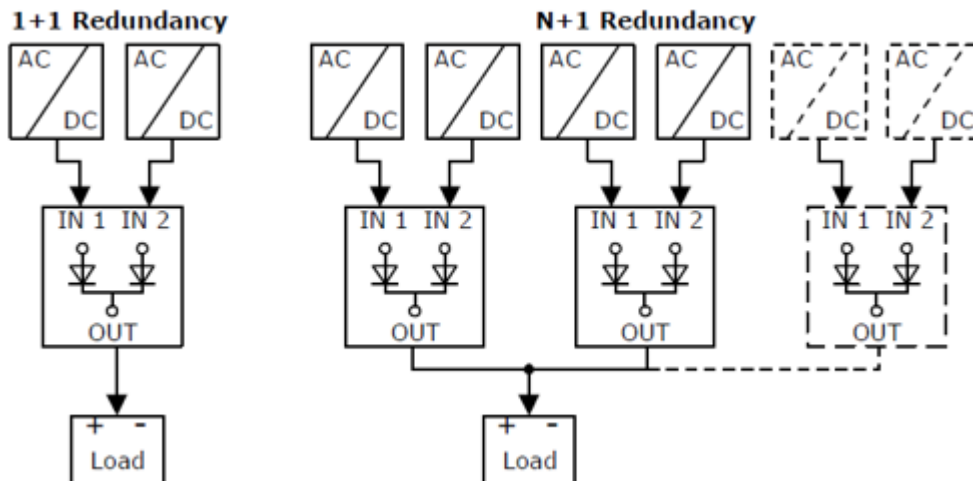

Fig. 1: Wiring diagram for 1+1 redundancy and N+1 redundancy

### 3 Technical data, mounting, wiring

#### 3.1 Input and output parameters

The device is designed to supply all kinds of loads, including unlimited capacitive and inductive loads. The input must be supplied from a PELV or SELV source in order to obtain a PELV or SELV output. Make sure the polarity of input and battery is correct. The device does not work if the voltage polarity is reversed.

Input and output parameters			
Number of inputs	-	2	
Number of outputs	-	1	
Input voltage	Nom.	DC 12-28 V	±30%
Input voltage range	-	8.4-36.4Vdc	
Voltage drop, input to output	Typ.	60 mV	With 2 x 5 A, see fig. below
	Typ.	110 mV	With 2 x 10 A, see fig. below
	Typ.	130 mV	With 2 x 12 A, see fig. below
Input current	Nom.	2x 0-12 A	Continuous operation, ambient temperature below +45 °C
	Nom.	2x 0-10 A	Continuous operation, ambient temperature below +70 °C
	Nom.	2x 16 A	For maximally 5 s
Peak input current	Max.	2x 700 A	For up to 1ms max.
Output current	Nom.	24A	Continuous operation, ambient temperature below +45 °C
	Nom.	20A	Continuous operation, ambient temperature below +70 °C
	Max.	32A	For maximally 5 s
Overcurrent protection at the output		-	
Overload/short circuit current	Max.	26 A (rms)	Applies to overloads that lead to voltages below 6 V. Make sure that the sum of the RMS input currents does not exceed this value
Reverse current	Max.	1 mA	At 24 V, per input, -40 °C to +70 °C
Reverse voltage	Max.	40 Vdc	Permissible continuous voltage at the output
Output capacity	Typ.	320µF	

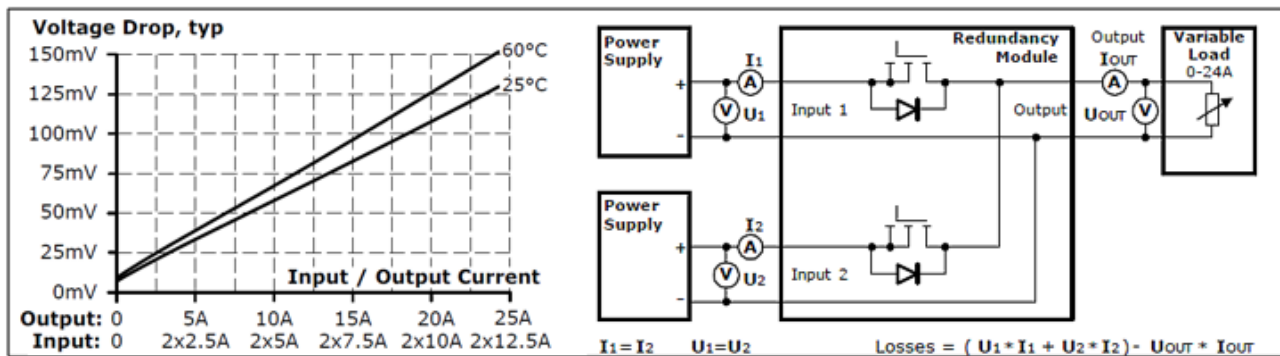

Fig. 2: Voltage drop between input and output if both inputs are drawing current, (typical 1+1 redundancy if the output voltages of both devices are identical)

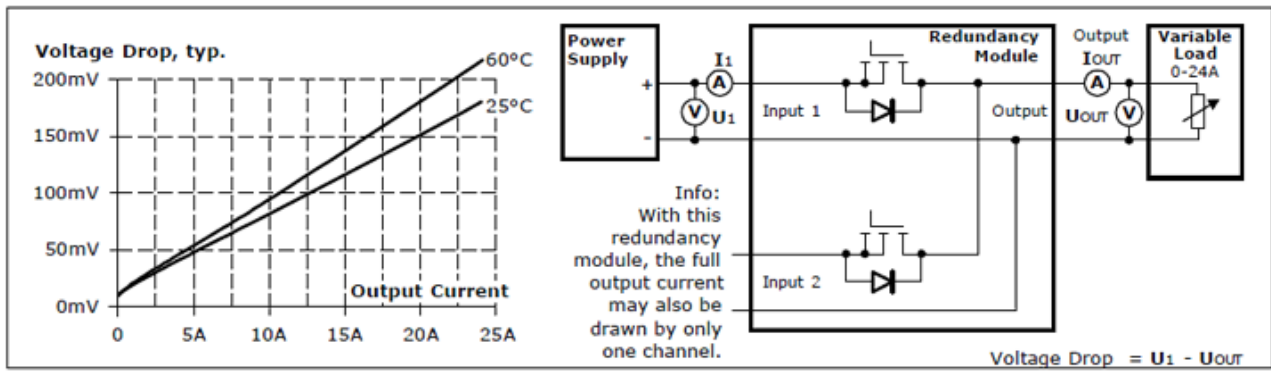

Fig. 3: Voltage drop between input and output if only one input is drawing current

### 3.2 Power loss

		DC 12V	DC 24 V	
Power loss	Typ.	0.6W	0.6W	At 2 x 5 A input current
	Typ.	2.0W	2.0W	At 2 x 10 A input current
Standby power loss	Typ.	0.11W	0.21W	With no output current

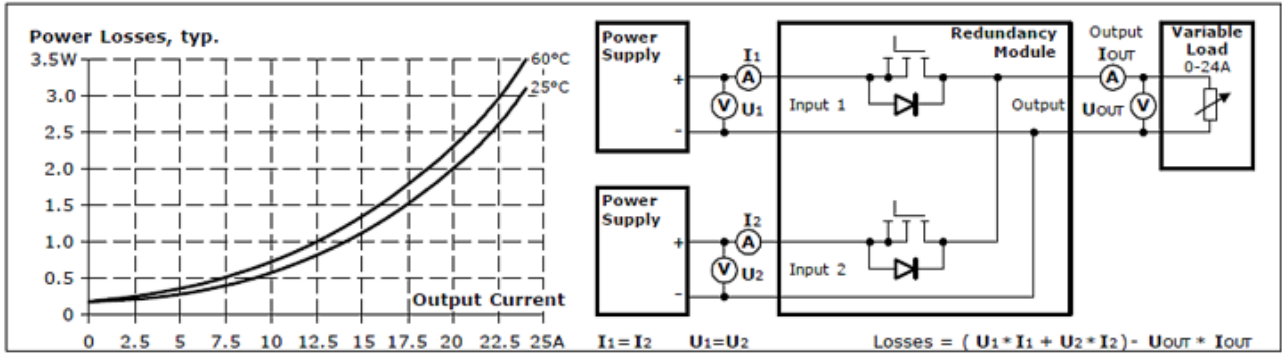

Fig. 4: Power loss if both inputs draw the same current

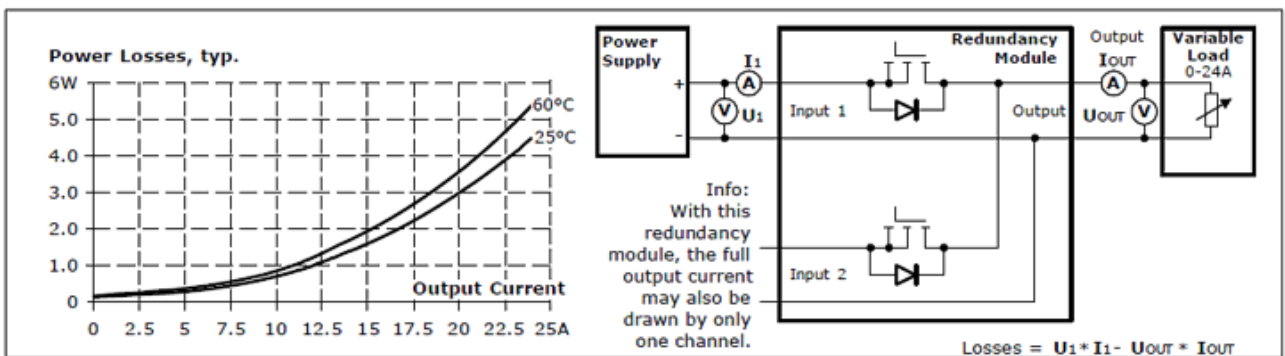

Fig. 5: Power loss if only one input is used

### 3.3 Functional wiring diagram

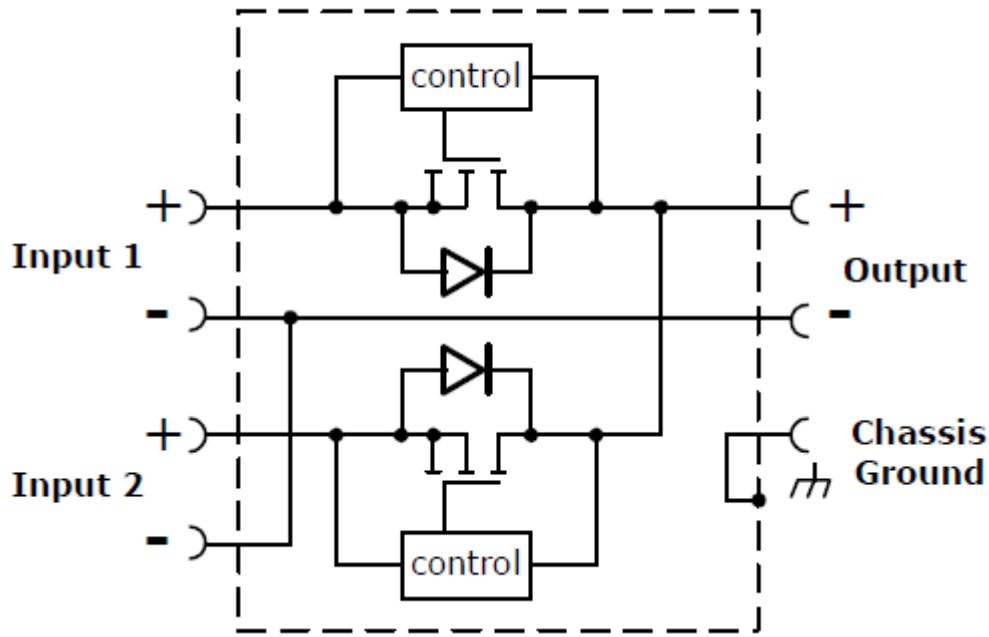

Fig. 6: Functional wiring diagram

### 3.4 Terminals and wiring

The terminals are designed to be finger-safe according to IP20 and are suitable for field or factory wiring.

	Input terminals	Output terminals
Type	Screw terminals	Screw terminals
Connection cross-section	e*: max. 6mm <sup>2</sup> f*: max. 4mm <sup>2</sup> a*: max 4mm <sup>2</sup> (d<2.8mm)	e*: max. 6mm <sup>2</sup> f*: max. 4mm <sup>2</sup> a*: max 4mm <sup>2</sup> (d<2.8mm)
Connection cross section (AWG)	e*: AWG 20-10 f*: AWG 20-10 a* AWG 20-10	e*: AWG 20-10 f*: AWG 20-10 a* AWG 20-10
Strip length	7mm	7mm

e\* = solid wire  
f\* = stranded wire  
a\* = with ferrule

### 3.5 Front side and connecting elements



Fig. 7: PS9401-2420-0000, front view

#### Output terminals (screw terminals)

Designation (A)	Description
+	Positive output
-	Negative output

#### Input terminals (screw terminals)

Designation (B1)	Description
+	Positive input channel 1
-	Negative input channel 1

Designation (B2)	Description
+	Positive input channel 2
-	Negative input channel 2

#### Chassis connection

Designation (C)	Description
chassis ground	A connection to PE or ground improves the EMC/ESD behavior.

### 3.6 Lifetime expectancy

The lifetime expectancy shown in the table indicates the minimum number of operating hours (service life) and is determined by the lifetime expectancy of the built-in electrolytic capacitors. The lifetime expectancy is stated in operating hours and is calculated according to the specifications of the capacitor manufacturer. The manufacturer of the electrolytic capacitors only guarantees a maximum life of up to 15 years (131,400h). Any number exceeding this value represents a calculated theoretical service life which can be used to compare devices.

Input/output current conditions	Input: 2x 5 A	Input: 2x 10 A	
	Output: 10A	Output: 20A	
Lifetime expectancy	553,000h	355,000h	At 24 V and +40 °C
	1,563,000h	1,003,000h	At 24 V and +25 °C

### 3.7 MTBF

MTBF stands for **Mean Time Between Failure**, which is calculated from the statistical failure rate of the components and indicates the reliability of a device. It is a statistical representation of the probability of equipment failure and does not necessarily represent the service life of a product.

The MTBF number is a statistical representation of the probability of equipment failure. An MTBF number of 1,000,000h, for example, means that statistically, if there are 10,000 devices in use, one device will fail every 100 hours. However, it is not possible to say whether the failed device has been in operation for 50,000 hours or only 100 hours.

For these device types the MTTF value (**Mean Time To Failure**) is identical to the MTBF value.

The redundancy module has two input channels that are fully independent of each other. Each control loop, each auxiliary voltage source or other circuits in the module are designed separately for each input. The redundancy module with two inputs can be regarded as two separate redundancy modules combined in one housing. The only common point is the track that connects the two separate circuits with each other at the output.

The following MTBF numbers refer to the complete dual input module. If the MTBF number is only required by one path, you simply double the value from the table.

Input/output current conditions	Input: 2x 5 A	Input: 2x 10 A	
	Output: 10A	Output: 20A	
MTBF	10,050,000h	7,895,000h	At 24 V and +40 °C
SN 29500, IEC 61709	16,777,000h	13,403,000h	At 24 V and +25 °C
MTBF MIL HDBK 217F	2,030,000h	1,890,000h	At 24 V, +40 °C Ground Fixed GF40
	2,801,000 h	2,588,000 h	At 24 V, +25 °C Ground Fixed GF25
	441,000h	404,000h	At 24 V, +40 °C, Ground Benign GB40
	604,000h	548,000h	At 24 V, +25 °C, Ground Benign GB25



### 3.8 EMC

The EMC behavior of the device is designed for applications in industrial environments as well as residential, commercial or small business environments.

The device was tested according to EN 61000-6-1, EN 61000-6-2, EN 61000-6-3 and EN 61000-6-4.

This device complies with FCC Part 15.

Operation is subject to the following two conditions: (1) This device may not cause harmful interference, and (2) this device must be able to deal with any interference received, including interference that may cause undesired operation.

EMC interference immunity		
Fast transients (burst)	EN 61000-4-4	Input cables, 2 kV, criterion A
		Output cables, 2 kV, criterion A

EMC interference emission		
Conducted interference emission, input lines	IEC/CISPR 16-1-2, IEC/CISPR 16-2-1	Limit values for DC power supply connections according to EN 61000-6-3 fulfilled
Conducted interference emission, output lines	IEC/CISPR 16-1-2, IEC/CISPR 16-2-1	Limit values for DC power supply connections according to EN 61000-6-3 fulfilled
Interference emission	EN 55011, EN 55022	Class B

Switching frequencies		
Converter for auxiliary supply voltage	140 to 500 kHz	The frequency depends on the input voltage

### 3.9 Environment

Environment		
Operating temperature	-40 °C to + 70 °C	The operating temperature corresponds to the ambient or environmental temperature and is defined as the air temperature 2 cm below the device.
Storage temperature	-40 °C to + 85 °C	For storage and transport
Output load reduction (derating)	0.16A/°C	Between +45 °C and +70 °C
	1.25A/1000m or 5°C/1000m	For altitudes >2000m, see Fig. <i>Output current over installation altitude</i>
	The derating is not hardware-controlled. The user must take this into account in order to stay below the reduced current limits, so that device overload is avoided.	
Moisture	5 to 95% r.h.	According to IEC 60068-2-30
Atmospheric pressure	110-54kPa	
Installation altitude	up to 5000m	
Degree of pollution	2	According to IEC 60664-1, non-conductive.
Pulse dielectric strength	1.5 kV	Between input and chassis (according to IEC 60664-1 overvoltage category II)
Oscillation, sinusoidal <sup>1)</sup>	2–17.8 Hz: ±1,6 mm; 17.8–500Hz: 2g 2 hours/axis	According to IEC 60068-2-6
Impacts <sup>1)</sup>	30 g 6 ms, 20 g 11 ms 3 impacts/direction, 18 impacts in total	According to IEC 60068-2-27

<sup>1)</sup> Tested in conjunction with DIN rails according to EN 60715 with a height of 15mm and a thickness of 1.3mm and standard installation position.

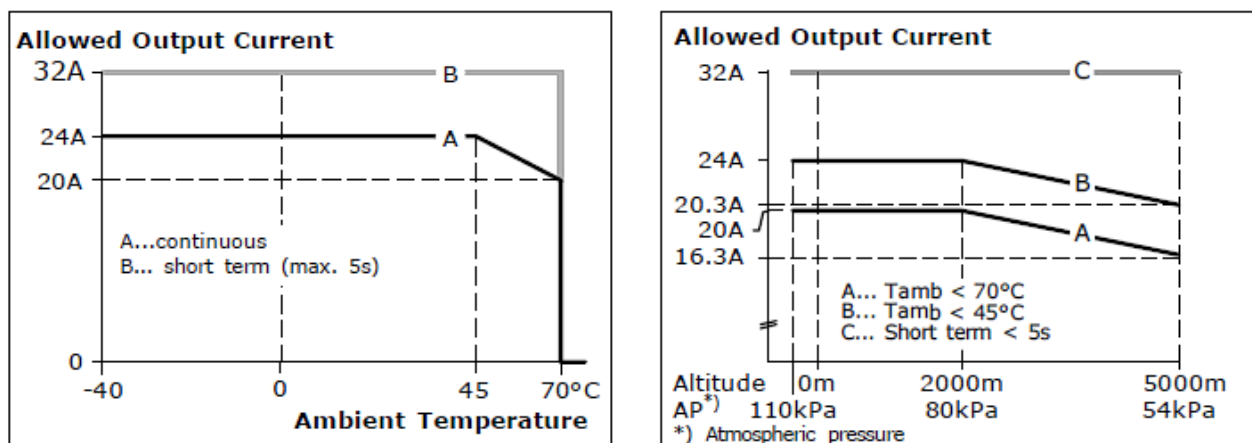

Fig. 8: Output current over ambient temperature; output current over installation altitude

### 3.10 Safety and protective functions

Safety and protective functions		
Insulation resistance	> 500MΩ	In the delivery state between the mains power connection and the housing, measured with 500 Vdc
PE resistance	< 0.1 ohm	Between housing and chassis ground terminal
Protection class	III	PE (Protective Earth) or chassis connection not necessary
Protection class	IP 20	According to EN/IEC 60529
Overtemperature protection	Not included	
Output overvoltage protection	Not included	
Internal input fuse	Not included	
Input overvoltage protection	Not included	
Input transient protection	Included	See chapter <a href="#">EMC [► 17]</a>
Output transient protection	Included	See chapter <a href="#">EMC [► 17]</a>
Protection against reverse polarity of the input	Included	Device will not start if the input voltage is reversed
Touch current (leakage current)	The leakage current generated by the module itself depends on the input voltage ripple and must be investigated in the final application. With an even DC input voltage, the leakage current generated is less than 100 µA.	

### 3.11 Dielectric strength

The input and output voltages are potential-free and have no resistive connection to ground.

The input and output voltages have the same electrical reference; there is no electrical isolation.

Type and component tests are carried out by the manufacturer. Field tests can be carried out using appropriate test devices that apply the voltage with a slow ramp (2 seconds up and 2 seconds down). Prior to the test, connect all input terminals with one another as well as all output poles. For the test, set the cut-off current to the value in the table below.

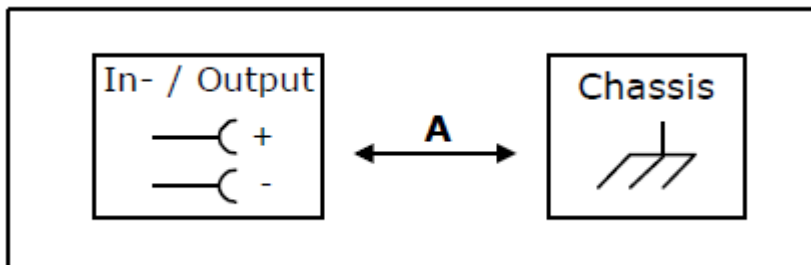





Fig. 9: Dielectric strength

		A
Type test	60s	500 Vac
Component test	5s	500 Vac
Field test	5s	500 Vac
Settings for the field test cut-off current	> 2 mA	

### 3.12 Declaration of conformity and approvals

	EU declaration of conformity
	UL Certificate: UL508, Applicable for US and Canada
	Classification: ATEX: EPS 11 ATEX 1 312 X, II 3G EX ec IIC T4 Gc
	Classification: IECEx EPS 21.0018X

### 3.13 Dimensions and weight

Dimensions and weight	
Overall width	32mm
Height	124mm
Depth	117mm The height of the DIN rails must be added to the depth of the device to calculate the total installation depth required
Weight	250g
DIN rail	Use 35 mm DIN rails according to EN 60715 or EN 50022 with a height of 7.5 or 15mm.
Housing material	Housing: Aluminum alloy Cover: galvanized steel
Ingress protection	Small parts such as screws, nuts, etc. with a diameter greater than 3.6 mm
Installation clearances	See chapter on <a href="#">Safety instructions and installation requirements</a> [► 9]

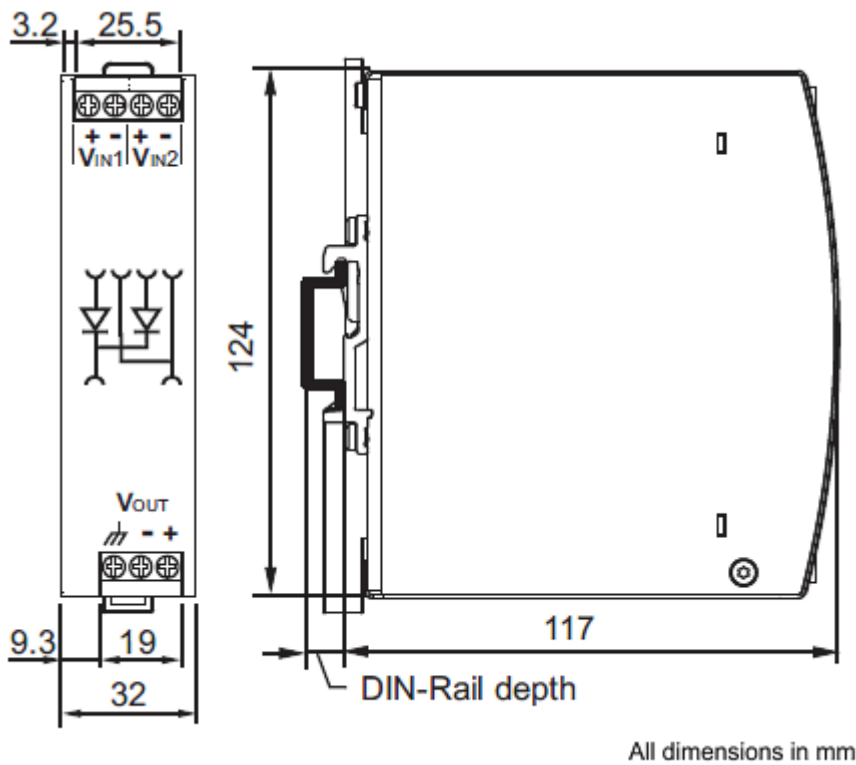

Fig. 10: Front/side view PS2001-2420-0000

## 4 Application notes

### 4.1 Recommendations for redundancy mode

Recommendations for the configuration of redundant power supply systems:

- Use separate input circuit breakers for each power supply.
- Use three-phase power supplies in order to ensure functional reliability in case of failure of a phase.
- If you use single-phase power supplies, connect them if possible to different phases or mains circuits.
- Set the power supply to "Parallel Use" mode if this function is available.
- It is advantageous to set the output voltages of all power supplies to the same value.

### 4.2 Lateral installation distances

Normally, the following installation clearances are recommended: 40 mm above, 20 mm below and 5 mm at the left and right-hand sides if the device is continuously loaded by more than 50% of the rated output. Increase this distance to 15 mm if the neighboring device is a source of heat (e.g. another power supply unit).

The distance between the power supply units and the redundancy module can be reduced to zero if the following conditions are met:

- 1+1 redundancy applications.
- The power supplies are also from Beckhoff.
- The redundancy module is located between the two power supply units.
- The output voltage is set to the same level on both power supply units.

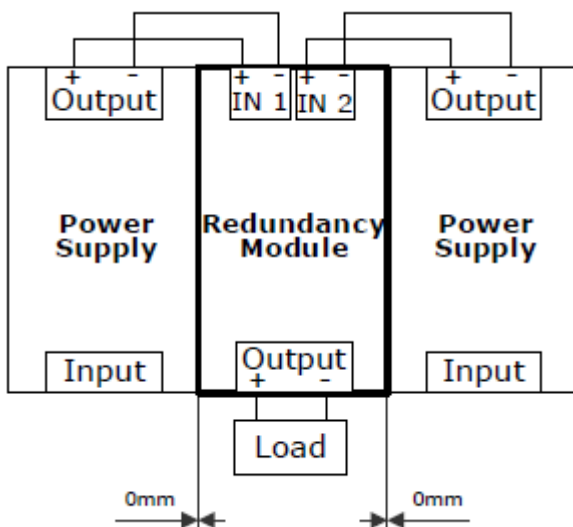

Fig. 11: Installation distances under the above conditions

### 4.3 Application examples

#### 1+1 redundancy up to 10 A

1+1 redundancy up to 10 A requires two 10 A power supply units and one 20 A redundancy module.

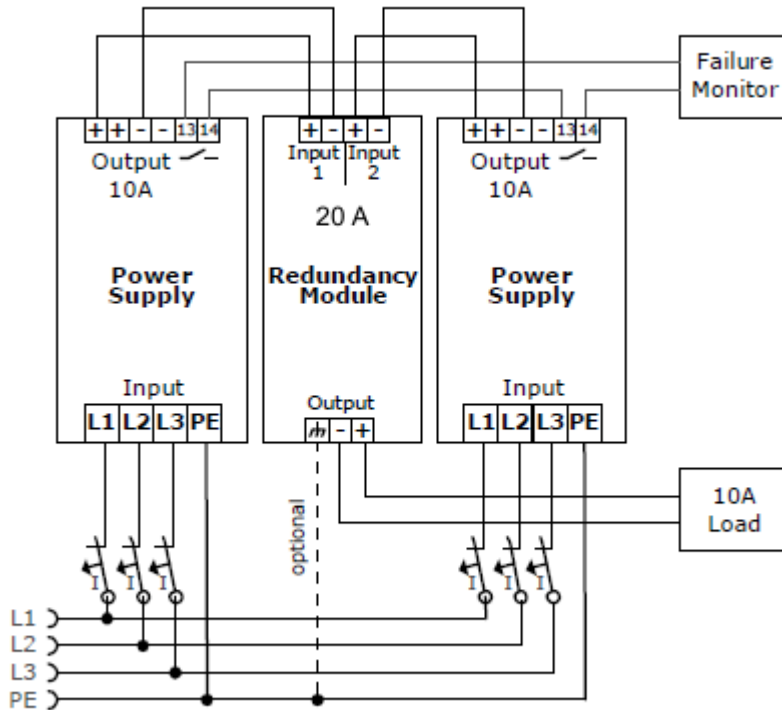

Fig. 12: Circuit diagram, 1+1 redundancy, 10 A output current

#### N+1 redundancy, example with 30 A

Four 10 A power supply units and two 20 A redundancy modules are required for an N+1 redundancy up to 30 A.

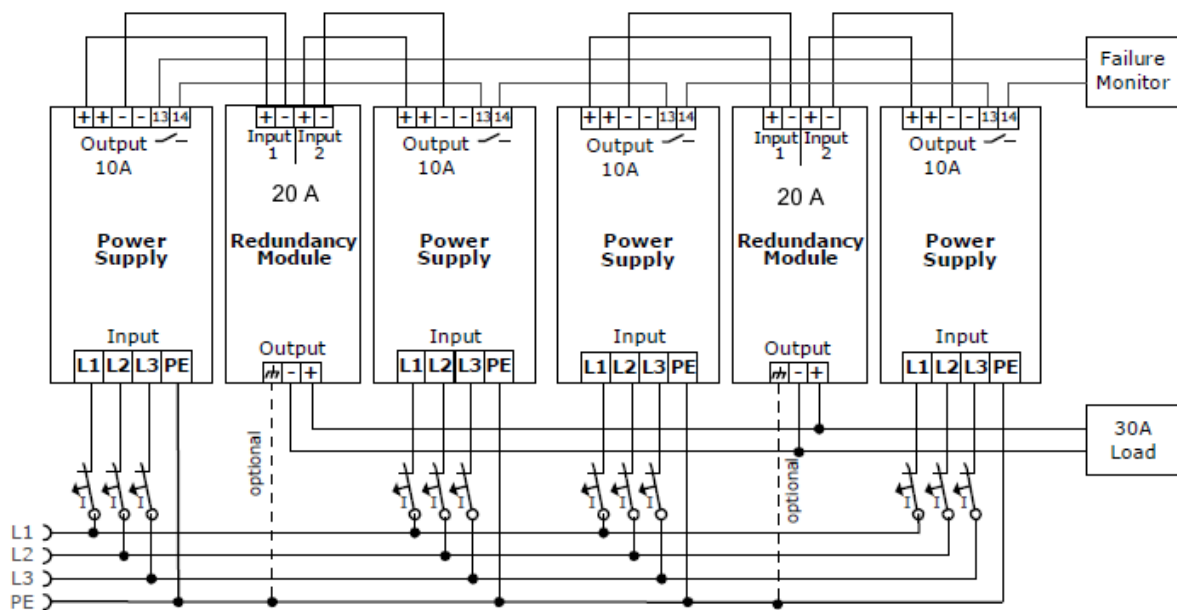

Fig. 13: Circuit diagram, N+1 redundancy, 30 A output current

## 4.4 Installation positions

Installation positions other than the input connections at the bottom and the output at the top require a reduction of the continuous output power or a limitation of the maximum permissible ambient temperature.

The values for service life and MTBF given in this data sheet are only valid for the standard mounting orientation.

The following curves give an indication of permissible output currents for altitudes up to 2000m.

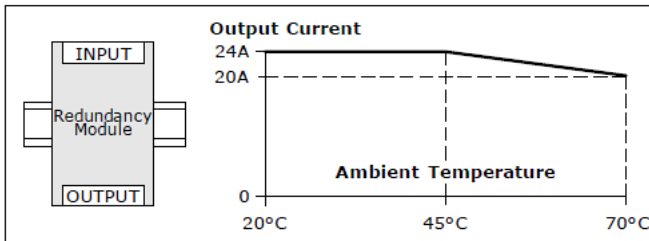

Fig. 14: Installation position A (standard installation position)

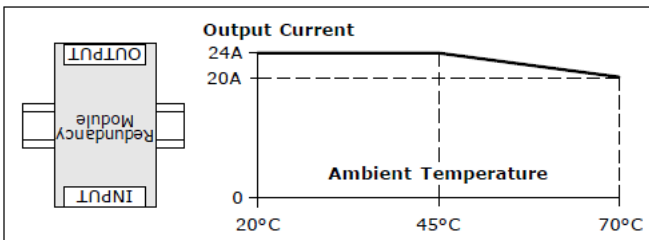

Fig. 15: Installation position B (upside down)

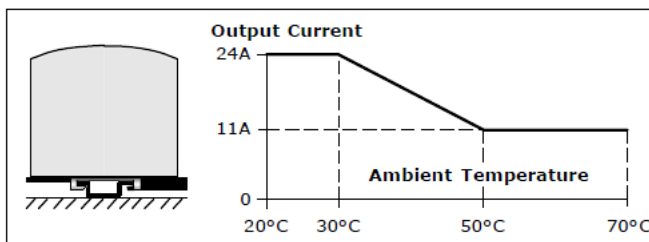

Fig. 16: Installation position C (table mounting)

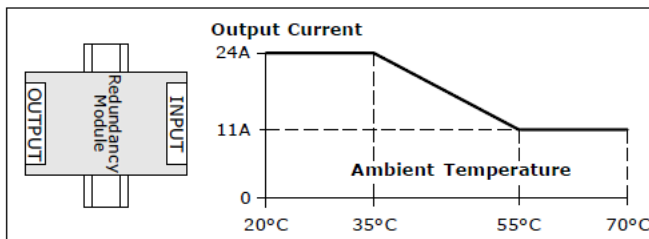

Fig. 17: Installation position D (horizontal clockwise)

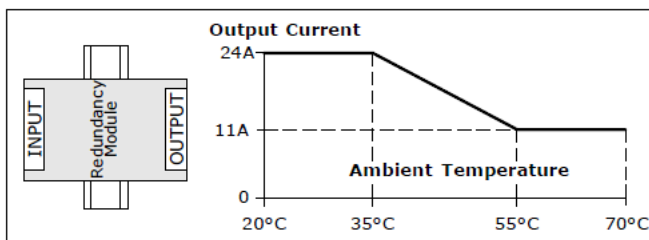

Fig. 18: Installation position E (horizontal counterclockwise)



## 5 Appendix

### 5.1 Accessories

#### ZS5301-0003 – Bracket for wall mounting

This bracket is used to mount the device on a level surface or panel without the use of a DIN rail. The bracket can be mounted without loosening the DIN rail brackets.

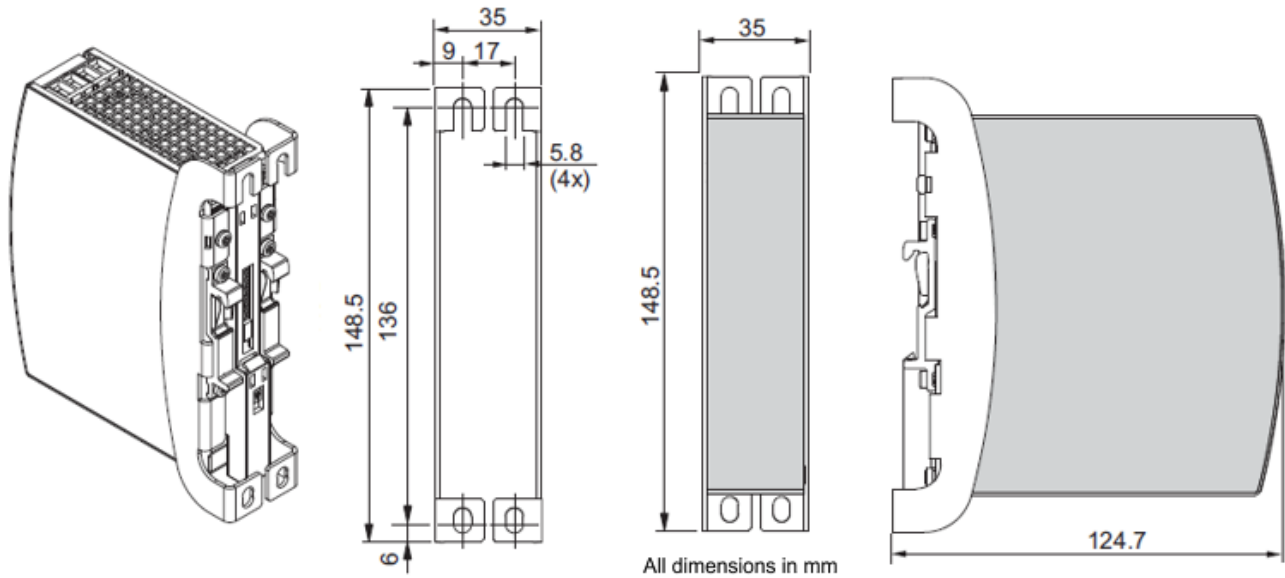

Fig. 19: Isometric view, installation dimensions of bracket for wall mounting

#### ZS5301-0004 – bracket for lateral mounting

This bracket is used in order to mount the devices laterally with or without the use of a DIN rail. The two aluminum brackets and the black plastic slider of the unit must be removed to allow the steel brackets to be mounted.

For lateral DIN rail mounting, the previously removed aluminum brackets and the black plastic slider must be mounted on the steel bracket.

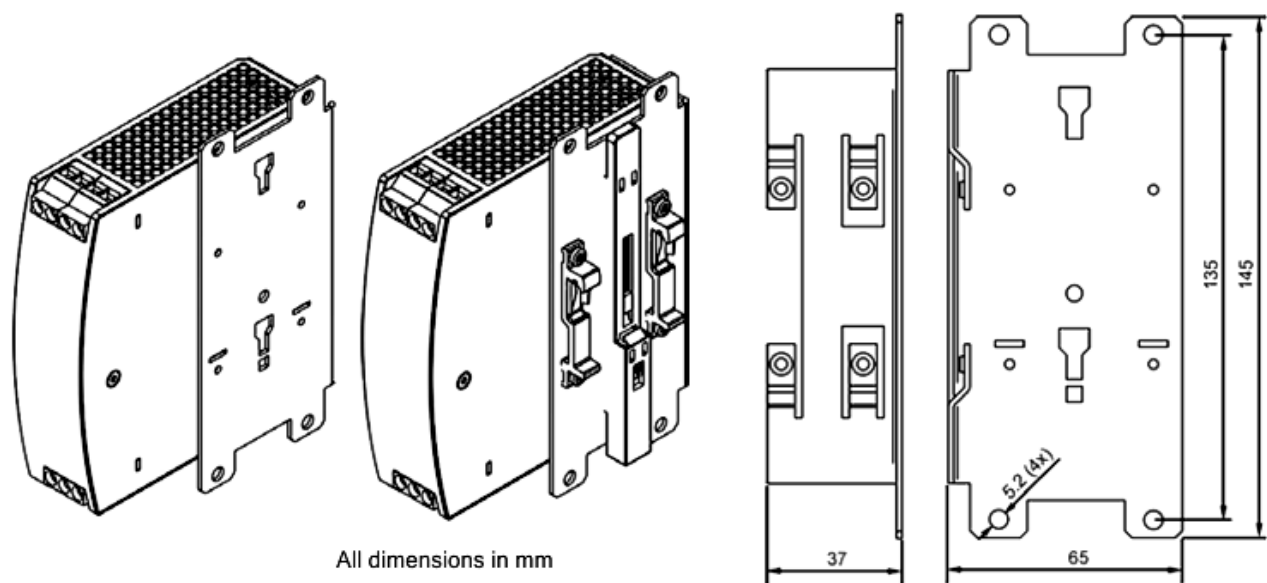

Fig. 20: Isometric view, lateral mounting without and with DIN rail bracket; mounting dimensions

## 5.2 Compatible power supplies for PS9401-2420-0000

Redundancy module	Power supplies	
	5 A	10 A
PS9401-2420-0000	PS1021-2405-0000	PS1011-2410-0000
	PS1061-2405-0000	PS2001-2410-0000
	PS2001-2405-0000	PS3001-2410-0001

### 5.3 Documentation issue status

Version	Comment
1.2.0	- Update chapter Technical data - Update structure
1.1	- Update chapter Safety instructions
1.0	- Corrections and addenda - 1 <sup>st</sup> public issue
0.2	- Corrections and addenda
0.1	- Provisional documentation for PS9401-2420-0000

## 5.4 Support and Service

Beckhoff and their partners around the world offer comprehensive support and service, making available fast and competent assistance with all questions related to Beckhoff products and system solutions.

### Beckhoff's branch offices and representatives

Please contact your Beckhoff branch office or representative for local support and service on Beckhoff products!

The addresses of Beckhoff's branch offices and representatives round the world can be found on her internet pages: [www.beckhoff.com](http://www.beckhoff.com)

You will also find further documentation for Beckhoff components there.

### Support

The Beckhoff Support offers you comprehensive technical assistance, helping you not only with the application of individual Beckhoff products, but also with other, wide-ranging services:

- support
- design, programming and commissioning of complex automation systems
- and extensive training program for Beckhoff system components

Hotline: +49 5246 963 157  
e-mail: [support@beckhoff.com](mailto:support@beckhoff.com)  
web: [www.beckhoff.com/support](http://www.beckhoff.com/support)

### Service

The Beckhoff Service Center supports you in all matters of after-sales service:

- on-site service
- repair service
- spare parts service
- hotline service

Hotline: +49 5246 963 460  
e-mail: [service@beckhoff.com](mailto:service@beckhoff.com)  
web: [www.beckhoff.com/service](http://www.beckhoff.com/service)

### Headquarters Germany

Beckhoff Automation GmbH & Co. KG

Hülshorstweg 20  
33415 Verl  
Germany

Phone: +49 5246 963 0  
e-mail: [info@beckhoff.com](mailto:info@beckhoff.com)  
web: [www.beckhoff.com](http://www.beckhoff.com)

## **Trademark statements**

Beckhoff®, TwinCAT®, TwinCAT/BSD®, TC/BSD®, EtherCAT®, EtherCAT G®, EtherCAT G10®, EtherCAT P®, Safety over EtherCAT®, TwinSAFE®, XFC®, XTS® and XPlanar® are registered trademarks of and licensed by Beckhoff Automation GmbH.

More Information:

[www.beckhoff.com/ps9401-2420-0000](http://www.beckhoff.com/ps9401-2420-0000)

Beckhoff Automation GmbH & Co. KG  
Hülshorstweg 20  
33415 Verl  
Germany  
Phone: +49 5246 9630  
[info@beckhoff.com](mailto:info@beckhoff.com)  
[www.beckhoff.com](http://www.beckhoff.com)

