

Documentation | EN

PS2001-2420-0000

Power supply 24 V DC, 20 A, 1-phase, AC 100-240 V



Table of contents

1 Overview	5
2 Foreword	6
2.1 Notes on the documentation	6
2.2 Safety instructions	7
2.3 Terminology and abbreviations	10
3 Technical data, mounting, wiring	11
3.1 AC input	11
3.2 DC input	13
3.3 Input inrush current	14
3.4 Output	15
3.5 Hold-up time	16
3.6 DC-OK relay contact	17
3.7 Efficiency and losses	18
3.8 Lifetime expectancy	19
3.9 MTBF	19
3.10 Terminals and wiring	20
3.11 Functional wiring diagram	21
3.12 Front side and operating elements	22
3.13 EMC	23
3.14 Environment	24
3.15 Protective functions	25
3.16 Safety features	25
3.17 Dielectric strength	26
3.18 Declaration of conformity and approvals	27
3.19 Dimensions and weight	28
4 Application notes	29
4.1 Peak current capability	29
4.2 Output circuit breakers	31
4.3 Charging batteries	32
4.4 Series connection	32
4.5 Parallel use to increase power	33
4.6 Parallel use for redundancy	34
4.6.1 1+1 Redundancy	34
4.6.2 N+1 Redundancy	35
4.7 Operation on two phases	36
4.8 Use in a sealed housing	36
4.9 Installation positions	37
5 Disposal	39
6 Appendix	40
6.1 Accessories	40
6.1.1 Redundancy and Buffer Modules	40
6.1.2 USV component	41
6.1.3 Accessories for mounting	42

6.2	Documentation issue status	43
6.3	Support and Service.....	44

1 Overview

PS2001-2420-0000 | Power supply 24V, 20A, 1-phase, Extra Power



- AC 100-240V wide-range input
- Width only 48mm
- Efficiency of up to 95.6%
- Excellent part-load efficiency
- 120% peak power, 576W
- Precise triggering of fuses through high overload / peak current
- Safe hiccup overload mode
- Active Power Factor Correction (PFC)
- Minimum inrush current surge
- Full output between -25°C and +60°C
- DC-OK relay contact
- Current-sharing function for parallel use

The PS2001-2420-0000 is a 1-phase 24 V power supply unit with an output current of 20 A and an output power of 480 W.

On the input side, the device features a wide-range input, Active Power Factor Correction (PFC) and inrush current limiting.

The output operates according to the UI characteristic curve and switches to the safe hiccup mode in case of overload/short-circuit. The PS2001-2420-0000 features a extra power with a continuous maximum output power of 120% and is able to trigger fuses precisely with a short-term peak current.

The power supply unit is part of the PS2000 family and has a width of 48 mm. A DC OK LED and a potential-free relay contact monitor the status of the output voltage. In addition to ATEC/IECEX; Class I Div2 approval, the power supply unit has a SEMI F47 certificate, which is a requirement in the semiconductor industry.

Overview of technical data ^{*)}

Overview of technical data	PS2001-2420-0000
Output voltage	DC24V (nominal factory setting 24.1V)
Adjustment range	24 - 28V
Output current	24.0-20.6A (amb. below +45°C) 20.0-17.1A (amb. at +60°C) 15.0-13.0A (amb. at +70°C) Linear load reduction between +45°C and +70°C
Input voltage AC	AC 100-240V -15%/+10%
Mains frequency	50-60Hz ±6%
Input current AC	4.26 / 2.23A at 120 / 230Vac
Input voltage DC	DC 110-150V ±20%
Efficiency	94.2 / 95.6% at 120 / 230Vac
Temperature range	-25°C to +70°C
Size (W x H x D)	48 x 124 x 117mm (without DIN rail)
Weight	830 g
Approvals/markings	CE, EAC, UKCA cULus Class I Div2 ATEX/IECEX SEMI F47

^{*)} All values typical for 24V, 20A, 230Vac, 50Hz, +25°C ambient temperature and after a warm-up period of five minutes, unless otherwise stated

2 Foreword

2.1 Notes on the documentation

Copyright

© Beckhoff Automation GmbH & Co. KG, Germany.

The reproduction, distribution and utilization of this document as well as the communication of its contents to others without express authorization are prohibited.

Offenders will be held liable for the payment of damages. All rights reserved in the event of the grant of a patent, utility model or design.

Disclaimer

The documentation has been prepared with care. The products described are, however, constantly under development.

We reserve the right to revise and change the documentation at any time and without prior announcement.

No claims for the modification of products that have already been supplied may be made on the basis of the data, diagrams and descriptions in this documentation.

Trademarks

Beckhoff®, TwinCAT®, TwinCAT/BSD®, TC/BSD®, EtherCAT®, EtherCAT G®, EtherCAT G10®, EtherCAT P®, Safety over EtherCAT®, TwinSAFE®, XFC®, XTS® and XPlanar® are registered trademarks of and licensed by Beckhoff Automation GmbH. Other designations used in this publication may be trademarks whose use by third parties for their own purposes could violate the rights of the owners.

Patent Pending

The EtherCAT Technology is covered, including but not limited to the following patent applications and patents: EP1590927, EP1789857, EP1456722, EP2137893, DE102015105702 with corresponding applications or registrations in various other countries.

Intended audience

This description is only intended for the use of trained specialists in control and automation engineering who are familiar with the applicable national standards.

It is essential that the documentation and the following notes and explanations are followed when installing and commissioning these components.

The qualified personnel is obliged to always use the currently valid documentation.

The responsible staff must ensure that the application or use of the products described satisfy all the requirements for safety, including all the relevant laws, regulations, guidelines and standards.

2.2 Safety instructions

Description of instructions

In this documentation the following instructions are used.
These instructions must be read carefully and followed without fail!

DANGER

Serious risk of injury!

Failure to follow this safety instruction directly endangers the life and health of persons.

WARNING

Risk of injury!

Failure to follow this safety instruction endangers the life and health of persons.

CAUTION

Personal injuries!

Failure to follow this safety instruction can lead to injuries to persons.

NOTICE

Damage to environment/equipment or data loss

Failure to follow this instruction can lead to environmental damage, equipment damage or data loss.



Tip or pointer

This symbol indicates information that contributes to better understanding.

Intended use

This device is designed for installation in a housing and is intended for general professional use, for example in industrial control systems or office, communication and measuring equipment.

Do not use this power supply in installations where a malfunction could cause serious injury or danger to human life.

Exclusion of liability

All the components are supplied in particular hardware and software configurations appropriate for the application. Modifications to hardware or software configurations other than those described in the documentation are not permitted, and nullify the liability of Beckhoff Automation GmbH & Co. KG.

Personnel qualification

This description is only intended for trained specialists in control, automation and drive engineering who are familiar with the applicable national standards.

Safety regulations

Please note the following safety instructions and explanations!
Product-specific safety instructions can be found on following pages or in the areas mounting, wiring, commissioning etc.

Safety instructions and installation requirements for PS2001-2420-0000 power supply unit**⚠ DANGER****Danger of electric shock, fire, injuries, injuries resulting in death!**

- Do not use the power supply without proper earthing (protective conductor). Use the terminal at the input terminal strip for the earth connection, not one of the screws on the housing.
- Switch off the power supply before working on the device. Provide protection against unintentional reconnection.
- Ensure proper wiring by following all local and national regulations.
- Do not modify or attempt to repair the device.
- Do not open the device, as high voltages are present inside.
- Avoid foreign bodies entering the housing.
- Do not use the device in damp locations or in areas where moisture or condensation is likely to occur.
- Do not touch the device when it is switched on or immediately after it has been switched off. Hot surfaces can cause burns.

⚠ WARNING**Explosion hazard warning!**

Do not use with DC input voltages.

Do not use with AC input voltages below 90Vac.

Use only in standard vertical mounting orientation with the input terminals at the bottom of the device.

Replacement of components may affect the suitability for this environment.

Do not disconnect the device from the mains and do not operate the voltage adjustment unless the power is switched off or the environment can be considered safe.

For the end product a suitable housing must be provided, which has a minimum protection class of IP54 and meets the requirements of EN 60079-0.

NOTICE**Instructions for use in potentially explosive atmospheres**

The device is suitable for use in the following areas:

Class I Division 2 Groups A, B, C, D

and for use in Group II environments of Category 3 (Zone 2).



Classification:

EPS 17 ATEX 1 089 X, II 3G EX ec nC IIC T4 Gc / IECEx EPS 20.0047X.

i Further notes on installation requirements

- This device contains no parts that require maintenance. If an internal fuse trips, this is due to an internal defect.
 - If any damage or malfunction occurs during installation or operation, turn off the power immediately and return the device to the factory for inspection.
 - Install the device in a housing that provides protection against electrical, mechanical and fire hazards.
 - Install the device on a DIN rail according to EN 60715, with the input terminals at the bottom of the device. Other mounting positions require a reduction of the output current.
 - Make sure that the wiring is correct. Make sure that all individual wires of a strand enter the terminal connection.
 - Use ferrules for wires at the input terminals. Unused screw terminals should be tightened firmly.
 - The device is designed for areas with contamination level 2 in controlled environments. No condensation or frost is allowed.
 - The device housing offers IP20 protection.
 - The device insulation is designed to withstand pulse voltages of overvoltage category III according to IEC 60664-1.
 - The device is designed to meet the requirements of protection class I according to IEC 61140.
 - Do not use without a proper PE connection (protective earth). For the earth connection use the terminal on the input block, not one of the screws on the housing.
 - The device is suitable for supply from TN, TT or IT networks. The continuous voltage between the input terminal and the PE potential must not exceed 300Vac.
 - The input can also be powered from batteries or similar DC power sources. The continuous voltage between the supply voltage and the PE/ground potential must not exceed 375Vdc.
 - An isolating device must be provided for the device input.
 - The device is designed for convection cooling and does not require an external fan. Do not obstruct the air flow or cover the ventilation grille!
 - The device is designed for altitudes up to 6000m (19685ft). Above 2000m (6560ft) a reduction of the output current and overvoltage category is required.
 - Maintain the following installation distances: 40 mm at the top, 20 mm at the bottom and 5 mm on the left and right are recommended if the device continuously runs at more than 50% of the rated output. Increase this distance to 15 mm if the adjacent device is a heat source (e.g. another power supply unit). If the device continuously runs at less than 50%, the 5 mm distance can be reduced to zero.
 - The device is designed, tested and approved for branch-circuit currents up to 32 A (IEC) and 30 A (UL) without additional protection. If an external fuse is used, do not use circuit breakers smaller than 10A (B or C characteristic) to avoid unwanted tripping of the circuit breaker.
 - The maximum ambient air temperature is +70°C (+158°F). The operating temperature corresponds to the ambient or ambient air temperature, per definition at 2 cm below the device.
 - The device is designed for operation in the relative humidity range between 5% and 95%.
-

2.3 Terminology and abbreviations

PE and the earthing symbol 	PE is the abbreviation for "protective earth" and has the same meaning as the earthing symbol 
Earth, ground	This document uses the term "earth" which is the same as the U.S. term "ground".
T.b.d.	Still to be defined, value or description will follow in due course.
AC 230 V	A value preceded by "AC" or "DC" represents a nominal voltage or a nominal voltage range. The nominal voltage or the nominal voltage range may be provided with tolerances. (e.g. AC 230 V $\pm 10\%$). The calculated total range then indicates the working range of the device. Example: DC 12 V refers to a 12 V battery, regardless of whether it is fully charged (13.7 Vdc) or discharged (10 Vdc).
230 Vac	A value followed by the unit Vac or Vdc is an instantaneous value that does not contain any additional tolerances.
50 Hz vs. 60 Hz	Unless otherwise specified, AC 100 V and AC 230 V parameters are valid at a mains frequency of 50 Hz. AC 120 V parameters are valid for a mains frequency of 60 Hz.
may	A keyword indicating a choice without implied preference.
shall	A keyword indicating a mandatory requirement.
should	A keyword indicating a choice with a clearly preferred method of implementation.

3 Technical data, mounting, wiring

3.1 AC input

AC input			
AC input	Nom.	AC 100-240V	Suitable for TN, TT and IT networks
AC input range	Min.	85-264Vac	Continuous operation
	Min.	264-300Vac	For up to 500ms max.
Permissible voltage L or N to earth	Max.	300Vac	Continuous according to IEC 60664-1
Input frequency	Nom.	50-60Hz	±6%
Turn-on voltage	Typ.	82Vac	Static, see Fig. <i>Input voltage range; switch-on behavior definitions</i>
Shut-down voltage	Typ.	72Vac	Static, see Fig. <i>Input voltage range; switch-on behavior definitions</i>

AC input		AC 100V	AC120V	AC230V	
Input current	Typ.	5.15A	4.26A	2.23A	At 24 V, 20 A, see Fig. <i>Input current over output current; power factor over output current</i>
Power factor*)	Typ.	0.996	0.996	0.980	At 24 V, 20 A, see Fig. <i>Input current over output current; power factor over output current</i>
Peak factor**)	Typ.	1.65	1.63	1.63	At 24V, 20A
Start-up delay	Typ.	450ms	450ms	450ms	See Fig. <i>Input voltage range; switch-on behavior definitions</i>
Rise time	Typ.	145ms	145ms	145ms	At 24 V, 20 A constant current load, 0 mF load capacity, see Fig. <i>Input voltage range; switch-on behavior definitions</i>
	Typ.	160ms	160ms	160ms	At 24 V, 20 A constant current load, 20 mF load capacity, see Fig. <i>Input voltage range; switch-on behavior definitions</i>
Turn-on overshoot	Max.	200 mV	200 mV	200 mV	See Fig. <i>Input voltage range; switch-on behavior definitions</i>

*) The power factor is the ratio of real (or active) power to apparent power in an AC circuit.

**) The peak factor is the mathematical ratio of the peak value to the RMS value of the input current waveform.

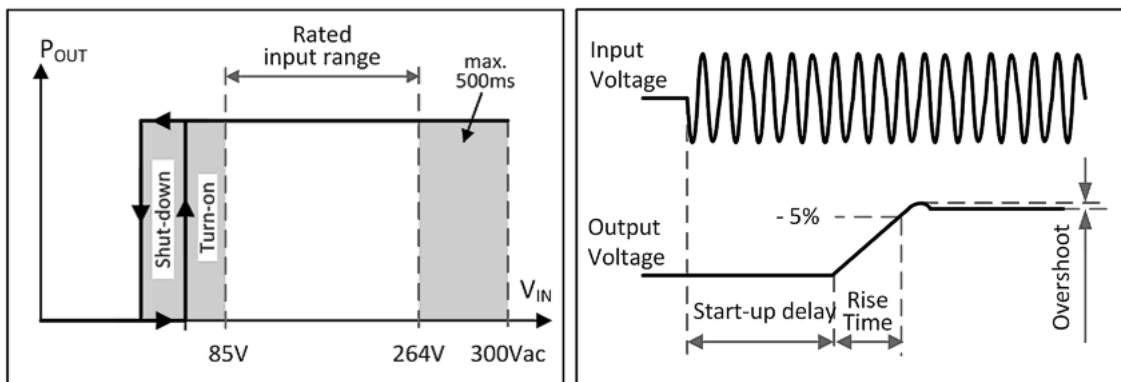

Fig. 1: Input voltage range; switch-on behavior definitions

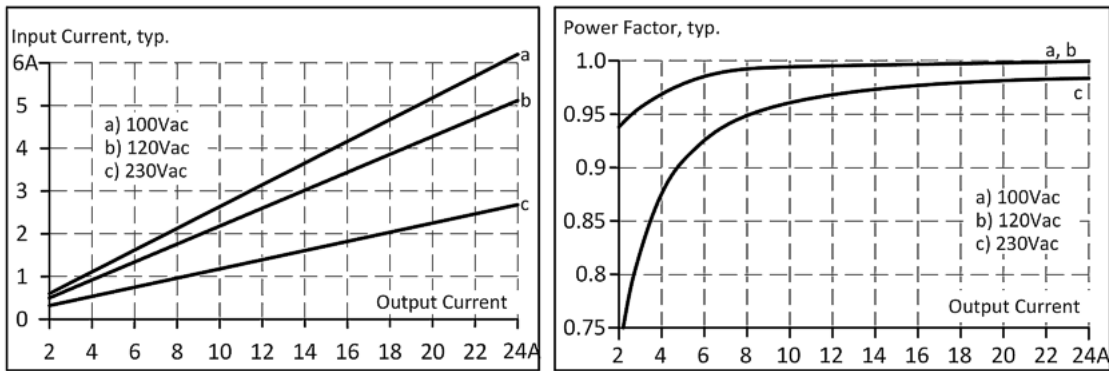

Fig. 2: Input current over output current; power factor over output current

3.2 DC input

DC input			
DC input	Nom.	DC 110-150V	±20%
DC input range	Min.	88-180Vdc	Continuous operation
DC input current	Typ.	4.64A	at 110Vdc, at 24V, 20A
DC input current	Typ.	1.66A	at 300Vdc, at 24V, 20A
Permissible voltage L or N to earth	Max.	375 Vdc	Continuous according to IEC 62477-1
Turn-on voltage	Typ.	80 Vdc	static
Shut-down voltage	Typ.	70 Vdc	static

Instructions for DC operation

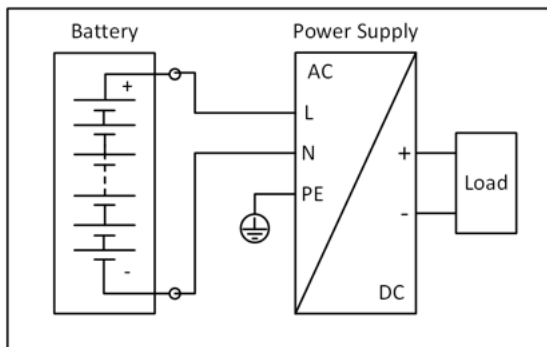

Fig. 3: Wiring for DC input

- Use a battery or a comparable DC source. Operation on the DC link of frequency converters is not recommended and may lead to defects or malfunctions.
- Connect the positive pole to L and the negative pole to N.
- Connect the PE terminal to the protective conductor or machine ground.

3.3 Input inrush current

Active inrush current limitation limits the inrush current surge after the input voltage is switched on.

The charge current of the interference suppression capacitors during the first few microseconds after switching on is not taken into account.

		AC 100V	AC 120V	AC 230V	
Input inrush current	Max.	15A _{peak}	12A _{peak}	5.5A _{peak}	temperature-independent
	Typ.	12A _{peak}	10A _{peak}	4.5A _{peak}	
Inrush energy	Max.	1A ² s	1A ² s	1A ² s	

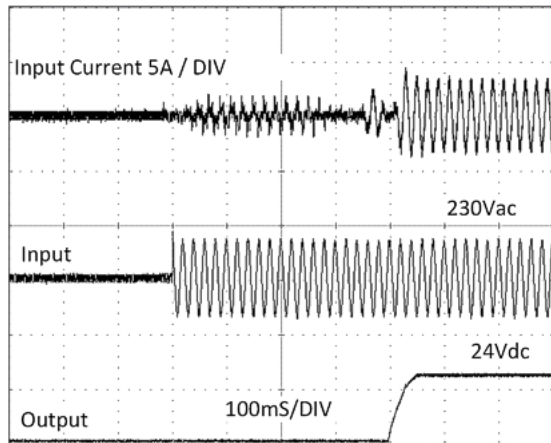

Fig. 4: Typical switch-on behavior at nominal load, 25°C ambient temperature

3.4 Output

The output provides an SELV/PELV/ES1 nominal voltage that is electrically isolated from the input voltage.

The device is designed to supply any type of load, including capacitive and inductive loads. If very large capacitors, such as EDLCs (electrical double-layer capacitors or "UltraCaps") with a capacitance > 1F are connected to the output, the device can charge the capacitor intermittently.

The output is electronically protected against overload, no-load and short circuit. In the event of a protection event, audible noises may occur

Output voltage	Nom.	24V	
Adjustment range	Min.	24-28V	Guaranteed value
	Max.	30.0V	This is the maximum output voltage that can occur in the end position of the potentiometer in clockwise direction due to tolerances. It is not a guaranteed value that can be achieved.
Factory settings	Typ.	24.1V	±0.2%, single use at full load (cold device) ±0.2%, parallel use at 20A (cold device) (23.9V ±0.2% at 24A and 25.1V ±0.2% at zero load)
Line regulation	Max.	10 mV	Between 85 and 300Vac
Load regulation	Max.	100 mV	Between 0 and 24A, static value, "single use"
	Typ.	1000 mV	Between 0 and 20A, static value, "parallel use", see Fig. <i>Output voltage over output current (parallel use) typ.</i>
Residual ripple and ripple voltage	Max.	50mV _{SS}	Bandwidth 20 Hz to 20 MHz, 50 Ohm
Output current	Nom.	24A ¹⁾	At 24 V and ambient temperature below 45°C
	Nom.	20A	At 24 V and 60°C ambient temperature
	Nom.	15A	At 24 V and 70°C ambient temperature
	Nom.	20.6A ¹⁾	At 28 V and ambient temperature below 45°C
	Nom.	17.1A	At 28 V and 60°C ambient temperature
	Nom.	13A	At 28 V and 70°C ambient temperature
	Linear derating between +45°C and +70°C		
Safety switch-off current	Typ.	60A	Up to 12ms once every five seconds, see Fig. <i>Dynamic output current capacity, typ.</i> The fuse switch-off current is an increased transient current that contributes to the tripping of fuses on faulty output branches. The output voltage remains above 20V.
Overload behavior		Continuous current	Output voltage > 13Vdc, see Fig. <i>Output voltage over output current, typ.</i>
		Hiccup mode ²⁾	Output voltage < 13Vdc, see Fig. <i>Output voltage over output current, typ.</i>
Short circuit current	Max.	29.8A	Continuous current, see Fig. <i>Output voltage over output current, typ.</i>
	Typ.	29A	Intermittent current peak value for typ. 2s Load impedance 10mOhm, see Fig. <i>Short circuit at the output</i> , The discharge current of the output capacitors is not included.
	max	9.8A	RMS value of the current, Load impedance 10mOhm, see Fig. <i>Short circuit at the output</i> ,
Output capacity	Typ.	8500µF	Included in the power supply
Load feedback	Max.	35V	The device is resistant to load feedback and will not indicate a malfunction if a load is feeding voltage back into the power supply. It does not matter whether the power supply is switched on or off. The absorbed energy can be determined by means of the built-in large-size output capacitor.

¹⁾ This continuous power / current is permissible up to an ambient temperature of +45°C. Above +45°C, use this power / current for a maximum duty cycle of 10%, i.e. no more than 1 minute every 10 minutes.

²⁾ In the event of heavy overload (when the output voltage drops below 13V), the power supply provides continuous output current for 2s. The output is then switched off for about 18 seconds before a new switch-on attempt is automatically made. This cycle is repeated as long as the overload persists. After the overload has been rectified, the device will operate normally. See Fig. *Short circuit at output, hiccup mode, typ.*

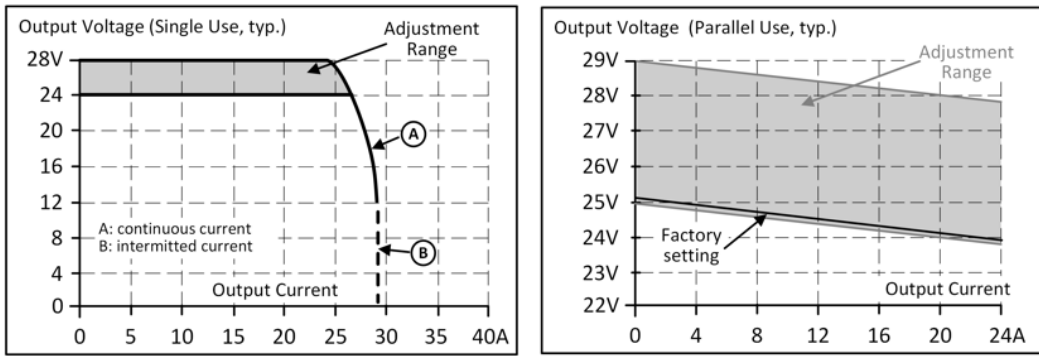

Fig. 5: Output voltage over output current (single use); output voltage over output current (parallel use)

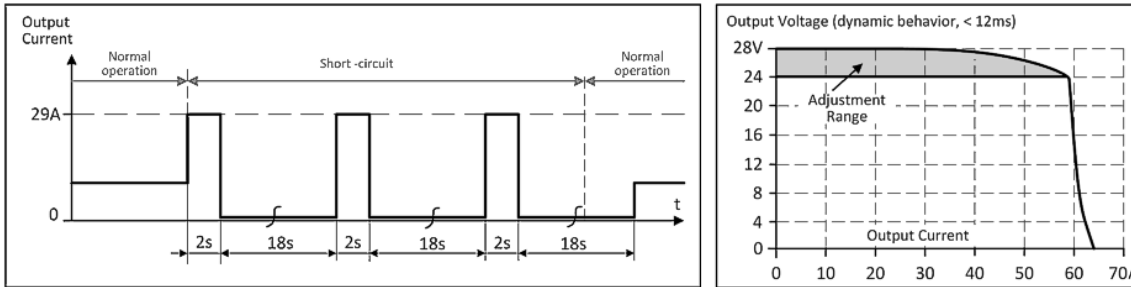

Fig. 6: Short circuit at output, hiccup mode, typ.; Dynamic output current capacity, typ.

3.5 Hold-up time

The Hold-up time is the time during which the output voltage of a power supply unit remains within the specification after a loss of input power. The Hold-up time depends on the output load. At no load the Hold-up time can be up to several seconds. The green DC-OK LED also lights up during this time.

		AC 100V	AC 120V	AC 230V	
Power failure Hold-up time	Typ.	65ms	65ms	65ms	At 24V, 10A, see Fig. <i>Hold-up time over input voltage</i>
	Min.	54ms	54ms	54ms	At 24V, 10A, see Fig. <i>Hold-up time over input voltage</i>
	Typ.	32ms	32ms	32ms	At 24V, 20A, see Fig. <i>Hold-up time over input voltage</i>
	Min.	24ms	24ms	24ms	At 24V, 20A, see Fig. <i>Hold-up time over input voltage</i>

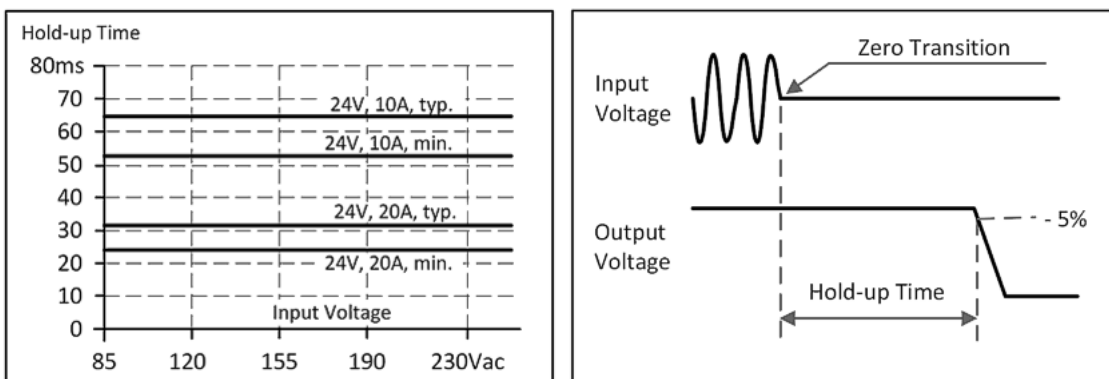

Fig. 7: Hold-up time over input voltage; switch-off behavior, definitions

3.6 DC-OK relay contact

This feature monitors the output voltage at the output terminals of an active power supply.

The contact closes	when the output voltage typically reaches 90% of the set output voltage.
The contact opens	when the output voltage drops more than 10% below the set output voltage. Short drops are extended to a signal length of 100ms. Drops that are shorter than 1ms are ignored.
Switching hysteresis	1 V
Contact load capacity	Maximum 60Vdc 0.3A, 30Vdc 1A, 30Vac 0.5A, ohmic load
	Minimum permissible load: 1mA at 5Vdc
Insulation voltage	See the dielectric strength table in the chapter on Safety features [▶ 25]

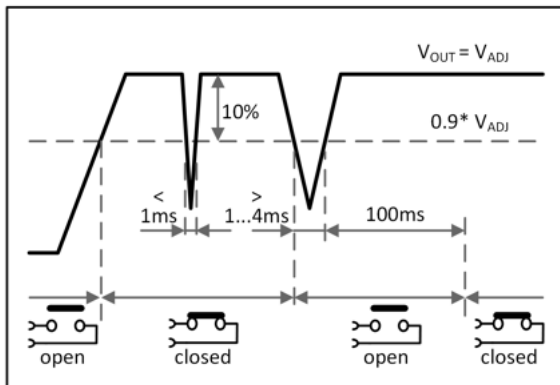

Fig. 8: Behavior of the DC-OK relay contact

3.7 Efficiency and losses

		AC 100V	AC 120V	AC 230V	
Efficiency	Typ.	93.6%	94.2%	95.6%	At 24V, 20A
	Typ.	93.5%	94.1%	95.5%	At 24V, 24A (Extra Power)
Average efficiency ^{*)}	Typ.	93.2%	93.8%	95.0%	25% at 5A, 25% at 10A, 25% at 15A. 25% at 20A
Losses	Typ.	2.5W	2.2W	2.2W	At 24V, 0A
	Typ.	16.0W	15.0W	12.5W	At 24V, 10A
	Typ.	32.8W	29.6W	22.1W	At 24V, 20A
	Typ.	40.0W	36.1W	27.1W	At 24V, 24A (Extra Power)

^{*)} The average efficiency is based on assumptions for a typical application with the power supply unit operating at 25% of the nominal load during 25% of the time, 50% of the nominal load during 25% of the time, 75% of the nominal load during 25% of the time and 100% of the nominal load during the remaining time.

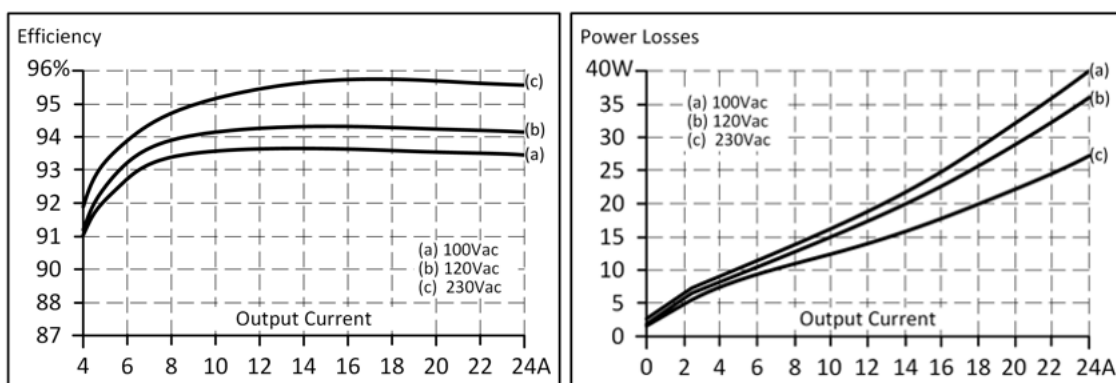

Fig. 9: Efficiency over output current; losses over output current

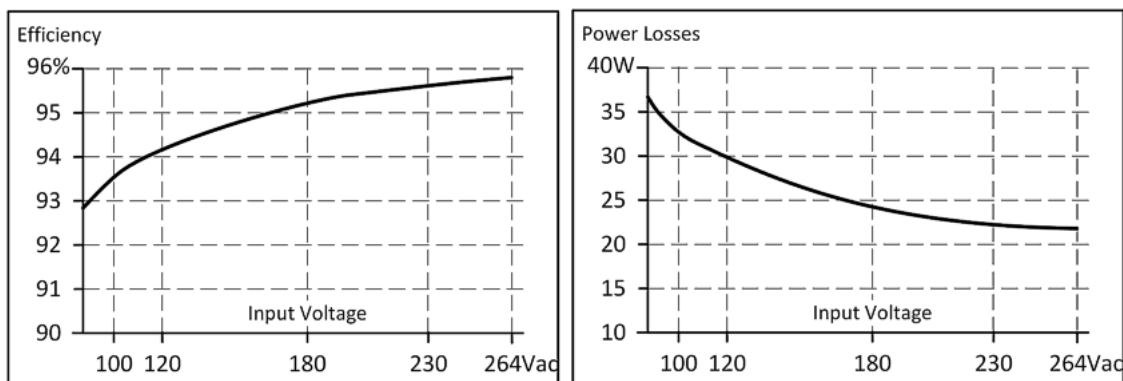

Fig. 10: Efficiency over input voltage; losses over input voltage

3.8 Lifetime expectancy

The lifetime expectancy shown in the table indicates the minimum number of operating hours (service life) and is determined by the lifetime expectancy of the built-in electrolytic capacitors. The lifetime expectancy is stated in operating hours and is calculated according to the specifications of the capacitor manufacturer. The manufacturer of the electrolytic capacitors only guarantees a maximum life of up to 15 years (131,400h). Any number exceeding this value represents a calculated theoretical lifetime which can be used to compare devices.

	AC 100V	AC 120V	AC 230V	
Lifetime expectancy	48,000h	60,000h	94,000h	At 24V, 20A and +40°C
	123,000h	149,000h	173,000h	At 24V, 10A and +40°C
	23,000h	31,000h	54,000h	At 24V, 24A and +40°C
	136,000h	169,000h	265,000h	At 24V, 20A and +25°C
	348,000h	422,000h	488,000h	At 24V, 10A and +25°C
	64,000h	88,000h	152,000h	At 24V, 24A and +25°C

3.9 MTBF

MTBF stands for **Mean Time Between Failure**, which is calculated from the statistical failure rate of the components and indicates the reliability of a device. It is a statistical representation of the probability of equipment failure and does not necessarily represent the service life of a product.

The MTBF number is a statistical representation of the probability of equipment failure. An MTBF number of 1,000,000h, for example, means that statistically, if there are 10,000 devices in use, one device will fail every 100 hours. However, it is not possible to say whether the failed device has been in operation for 50,000 hours or only 100 hours.

For these device types the MTTF value (**Mean Time To Failure**) is identical to the MTBF value.

	AC 100V	AC 120V	AC 230V	
MTBF SN 29500, IEC 61709	422,000h	445,000h	590,000h	At 24V, 20A and +40°C
	790,000h	832,000h	1,060,000h	At 24V, 20A and +25°C
MTBF MIL HDBK 217F	186,000h	191,000h	226,000h	At 24V, 20A and +40°C; Ground Benign GB40
	256,000h	263,000h	313,000h	At 24V, 20A and +25°C; Ground Benign GB25
	40,000h	42,000h	50,000h	At 24V, 20A and +40°C; Ground Fixed GF40
	53,000h	55,000h	67,000h	At 24V, 20A and +25°C; Ground Fixed GF25

3.10 Terminals and wiring

The terminals are designed to be finger-safe according to IP20 and are suitable for field or factory wiring.

Technical data	Input	Output	DC-OK signal
Connection cross-section	e*: max. 6mm ² f*: max. 4mm ² a*: max. 4mm ² (d<2.8mm)	e*: max. 6mm ² f*: max. 4mm ² a*: max 4mm ² (d<2.8mm)	e*: max. 1.5mm ² f*: max. 1.5mm ² a*: max. 1.5mm ² (d<1.6mm)
Connection cross section (AWG)	e*: AWG 20-10 f*: AWG 20-10 a* AWG 20-10 (d<2.8mm)	e*: AWG 20-10 f*: AWG 20-10 a* AWG 20-10 (d<2.8mm)	e*: AWG 24-16 f*: AWG 24-16 a*: AWG 24-16 (d<1.6mm)
Strip length	7mm / 0.28inch	7mm / 0.28inch	7mm / 0.28inch

e* = solid single wire
f* = stranded wire
a* = with ferrule

Wiring instructions:

- Use suitable copper cables that are designed for at least the following operating temperatures: +60°C for ambient temperatures up to +45°C, +75°C for ambient temperatures up to +60°C, and +90°C for ambient temperatures up to +70°C.
- Observe the national installation rules and regulations!
- Make sure that all single wires of a strand are connected to the terminal!
- Unused terminals should be tightened firmly.
- Ferrules are permitted.

Series connection of power supply units:

Power supply units may be connected in series.

Please use a separate distribution terminal strip as shown in Fig. *Use of distribution terminals*.

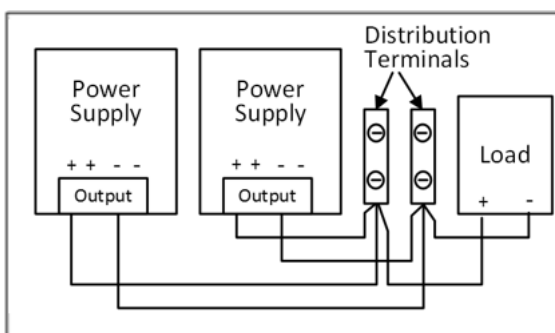

Fig. 11: Use of distribution terminals

3.11 Functional wiring diagram

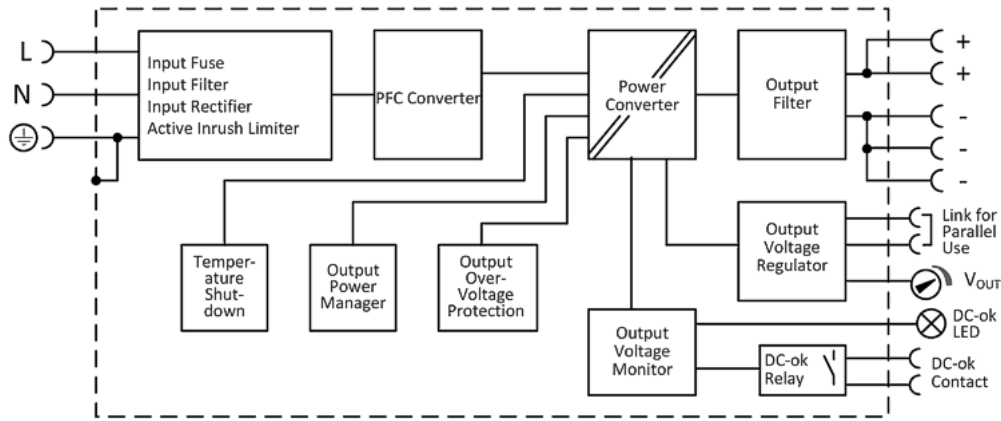

Fig. 12: Functional wiring diagram

3.12 Front side and operating elements

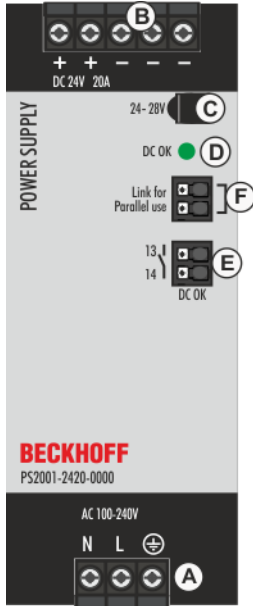



Fig. 13: Front PS2001-2420-0000

Input terminals (screw terminals)

Designation (A)	Description
N	Mains input N
L	Mains input L
	PE input (protective conductor)

Output terminals (screw terminals)

Designation (B)	Description
+	two identical positive poles, positive output
-	three identical negative poles, negative output

Potentiometer for the output voltage

Designation (C)	Description
Potentiometer cover	Open the flap to adjust the output voltage. Factory setting: 24.1 V

DC-OK LED

Designation (D)	Description
LED green	Lights when the output voltage has reached 90% of the set output voltage.

DC-OK relay contact

Designation (E)	Description
Push-in terminals 13 / 14	Monitors the output voltage of the active power supply. See chapter on DC OK relay contact [▶ 17] for more information.

"Parallel Use" "Single Use" connection

Designation (F)	Description
Push-in terminals "Link for parallel use"	Connect the two terminals when power supplies are connected in parallel. In order to achieve a distribution of the load current to the individual power supplies, the output voltage is regulated in parallel connection mode such that the voltage at no load is approx. 4% higher than at nominal load. See also chapter on Parallel use for power increase [▶ 33].

3.13 EMC

The EMC behavior of the device is designed for applications in industrial environments as well as residential, commercial or small business environments. The output may be earthed or non-earthed.

The device was tested according to EN 61000-6-1, EN 61000-6-2, EN 61000-6-3 and EN 61000-6-4.

Without additional measures to reduce emissions at the output (e.g. by using a filter), the device is not suitable for supplying a local DC power network in residential, commercial or small business environments. There are no restrictions for local DC power networks in industrial environments.

EMC interference immunity			
Strong transients	VDE 0160	Over the entire load range	750V, 0.3ms Criterion A

EMC interference emission		
Cable-related interference emission, input lines	EN 55011, EN 55022, FCC Part 15, CISPR 11, CISPR 22	Class B
Interference emission	EN 55011, EN 55022	Class B
Harmonic input current	EN 61000-3-2	Class A requirements met Class C met between 8A and 24A load
Voltage fluctuations, flicker	EN 61000-3-3	Requirements met ¹⁾

This device complies with FCC Part 15.

Operation is subject to the following two conditions: (1) This device may not cause harmful interference, and (2) this device must be able to deal with any interference received, including interference that may cause undesired operation.

¹⁾ Tested with constant current loads, non-pulsating

Switching frequencies		
PFC converter	100kHz	fixed frequency
Main converter	80kHz to 140kHz	Output load dependent
Auxiliary converter	60kHz	fixed frequency

3.14 Environment

Environment		
Operating temperature ¹⁾	-25°C to +70°C	Reduction of the output power according to Fig. <i>Output current over ambient temperature</i>
Storage temperature	-40°C to +85°C	For storage and transport
Output load reduction (derating)	6.4W/°C 12W/°C	+45°C to +60°C / +60°C to +70°C
	1.33A/1000m or 5°C/1000m	For altitudes >2000m, see Fig. <i>Output current over installation altitude</i>
	The derating is not hardware-controlled. The user must take this into account in order to stay below the reduced current limits, so that device overload is avoided.	
Moisture	5 to 95% r.h.	According to IEC 60068-2-30 Do not energize if there is condensation.
Atmospheric pressure	110-47kPa	see Fig. <i>Output current over installation altitude</i>
Installation altitude	up to 6000m	see Fig. <i>Output current over installation altitude</i>
Overvoltage category	III	According to IEC 60664 -1, installation altitudes up to 2000m
	II	According to IEC 60664 -1, installation altitudes above 2000m
Degree of pollution	2	According to IEC 62477-1, non-conductive
Oscillation, sinusoidal ²⁾	2–17.8Hz: ±1.6mm; 17.8-500Hz: 2g 2 hours/axis	According to IEC 60068-2-6
Impacts ²⁾	30g 6ms, 20g 11ms 3 impacts/direction, 18 impacts in total	According to IEC 60068-2-27
LABS-free	The device does not release any silicones or other paint-wetting impairment substances and is suitable for use in paint shops.	
Corrosive gas	Tested according to ISA-71.04-1985, Severity Level G3, IEC 60068-2-60 Test Ke Method 4 for a service life of at least 10 years in these environments.	
Audible noises	In the event of no-load, overload or short circuit, the power supply unit emits audible noises.	

¹⁾ The working temperature is identical to the room temperature or the ambient temperature and is defined as the air temperature 2cm below the device.

²⁾ Tested in conjunction with DIN rails according to EN 60715 with a height of 15mm and a thickness of 1.3mm and standard mounting position.

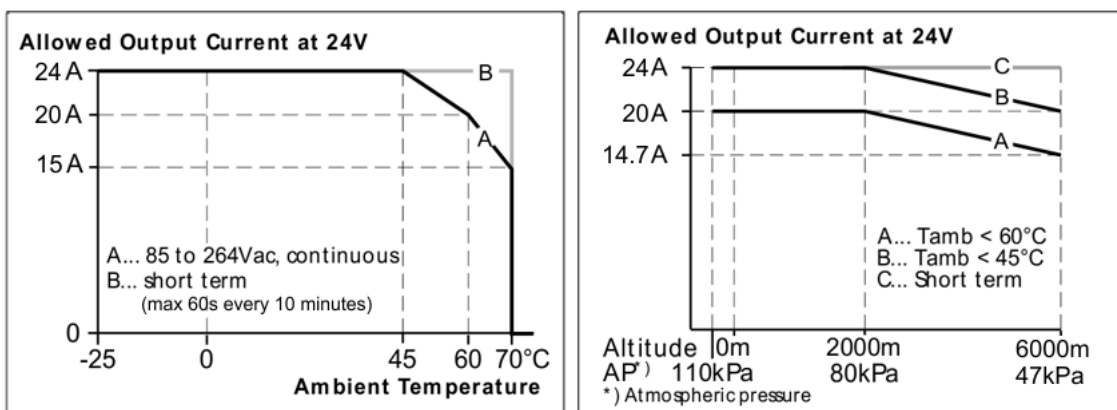

Fig. 14: Output current over ambient temperature; output current over installation altitude

3.15 Protective functions

Protective functions		
Output overvoltage protection	Typ. 30.5Vdc Max. 32Vdc	In the event of an internal power supply fault, a redundant circuit limits the maximum output voltage. The output switches off and automatically tries to switch on again.
Protection class	IP 20	EN/IEC 60529
Overtemperature protection	Yes	Output shutdown with automatic restart. The temperature sensor is installed at critical components within the device and switches off the device in safety-critical situations (e.g. load reduction requirements not met, excessive ambient temperature, ventilation blocked or load reduction not observed if the mounting direction is different). There is no correlation between the operating temperature and the switch-off temperature, since the latter depends on the input voltage, the load and the installation type.
Protection against input transients	MOV (metal oxide varistor)	For further information see EMC chapter ▶ 23
Input fuse	Included	Non-replaceable slow-blow fuse with high load capacity

3.16 Safety features

Safety features		
Protection class	I	Conforms to IEC 61140 PE (protective conductor) connection required
Insulation resistance	> 500MΩ	In the delivery state between input and output, measured with 500Vdc
	> 500MΩ	In the delivery state between input and protective conductor, measured with 500Vdc
	> 500MΩ	In the delivery state between output and protective conductor, measured with 500Vdc
	> 500MΩ	In the delivery state between output and DC OK contacts, measured with 500Vdc
PE resistance	< 0.1Ω	Resistance between the protective conductor connection and the housing near the DIN rail mounting bracket.
Leakage current	Typ. 0.12mA / 0.31mA	At 100Vac, 50Hz, TN, TT / IT network
	Typ. 0.18mA / 0.45mA	At 120Vac, 60Hz, TN, TT / IT network
	Typ. 0.30mA / 0.76mA	At 230Vac, 50Hz, TN, TT / IT network
	Max. 0.16mA / 0.38mA	At 110Vac, 50Hz, TN, TT / IT network
	Max. 0.23mA / 0.55mA	At 132Vac, 60Hz, TN, TT / IT network
	Max. 0.39mA / 0.94mA	At 264Vac, 50Hz, TN, TT / IT network

3.17 Dielectric strength

The output voltage is earth-free and has no ohmic connection to earth.
The output is isolated from the input by double or reinforced insulation.

Type and component tests are carried out by the manufacturer. Field tests can be performed in the field using suitable test equipment that ramps up the voltage with a slow ramp (2s rising and 2s falling). Connect all input terminals and all output poles to each other before performing the tests. During the test, set the cut-off current to the value shown in the table below.

We recommend connecting either the positive pole, the negative pole or another part of the output circuit to the protective conductor system. This avoids situations in which the load starts unexpectedly or cannot be disconnected if an unnoticed earth leakage occurs.

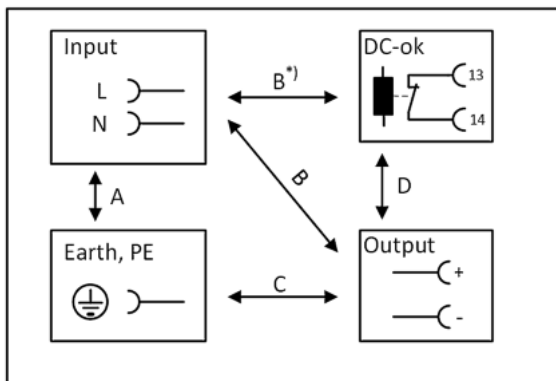









Fig. 15: Dielectric strength

B^{*)} When checking the input to DC-OK, make sure that the maximum voltage between DC-OK and the output is not exceeded (column D). When performing the test, we recommend connecting the DC OK contact pins and the output contact pins.

		A	B	C	D
Type test	60s	2500Vac	3000Vac	1000Vac	500Vac
Component test	5s	2500Vac	2500Vac	500Vac	500Vac
Field test	5s	2000Vac	2000Vac	500Vac	500Vac
Setting the cut-off current		> 10mA	> 10mA	> 20mA	> 1mA

3.18 Declaration of conformity and approvals

	<p>EU declaration of conformity</p>
	<p>UK Declaration of Conformity Trade conformity assessment for England, Scotland and Wales The UKCA mark indicates conformity with the UK Statutory Instruments 2016 No. 1101 (LVD) 2016 No. 1091 (EMC) and 2012 No. 3032 (RoHS)</p>
	<p>Registration for the Eurasian Customs Union market (Russia, Kazakhstan and Belarus)</p>
	<p>UL Certificate: UL 61010-1/2-201, Applicable for US and Canada</p>
	<p>UL Certificate: Class I Division 2 Groups A, B, C, D locations and for use in Group II Category 3 (Zone 2) environments Applicable for US and Canada</p>
	<p>Classification: ATEX: EPS 17 ATEX 1 089 X, II 3G EX ec nC IIC T4 Gc</p>
	<p>Classification: IECEx EPS 20.0047X</p>

3.19 Dimensions and weight

Dimensions and weight	
Overall width	48mm
Height	124mm
Depth	127mm The height of the DIN rails must be added to the depth of the device to calculate the total installation depth required
Weight	830 g
DIN rail	Use 35 mm DIN rails according to EN 60715 or EN 50022 with a height of 7.5 or 15mm.
Housing material	Housing: Aluminum alloy Cover: Galvanized steel
Ingress protection	Small parts such as screws, nuts, etc. with a diameter greater than 5 mm
Installation clearances	See chapter on <u>Safety instructions and installation requirements</u> [► 9]

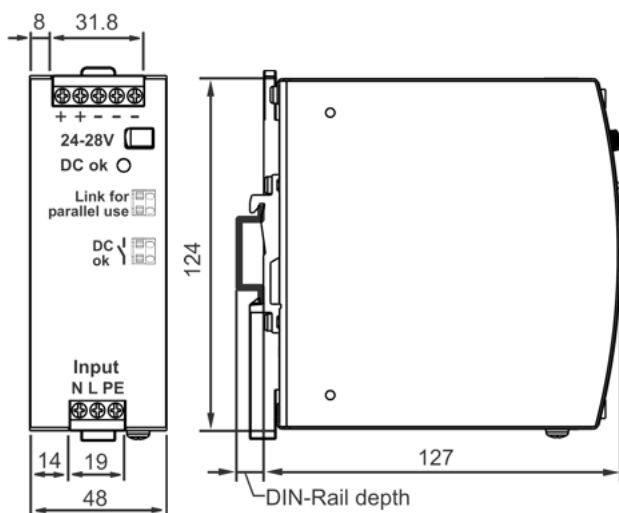

Fig. 16: Front/side view PS2001-2420-0000

4 Application notes

4.1 Peak current capability

The device can deliver peak currents (for up to several milliseconds) that are higher than the specified short-term currents.

This helps when starting loads with high current intensity. Magnetic coils, contactors and pneumatic modules often have a stationary coil and a pick-up coil. The inrush current requirement of the pick-up coil is several times higher than the stationary current and usually exceeds the rated output current (including extra power). The situation is exactly the same when starting a capacitive load.

The peak current capability also ensures safe operation of downstream circuit breakers of load circuits. The load circuits are often individually fused with circuit breakers or fuses. In the event of a short circuit or overload in a circuit, the fuse or circuit breaker needs a certain amount of overcurrent to open in time. This prevents a voltage drop in adjacent circuits.

The additional current (peak current) is supplied by the power converter and the built-in large-size output capacitors of the power supply unit. The capacitors are discharged during such an event, which leads to a voltage drop at the output. The following two examples show typical voltage drops for ohmic loads:

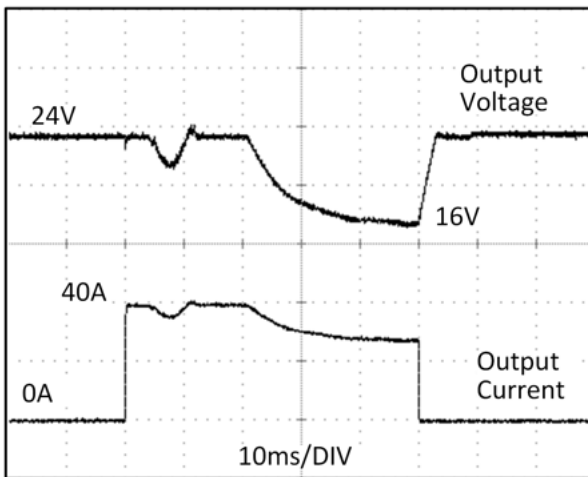

Fig. 17: 40A peak current for 50ms, typ. (2x nominal current)

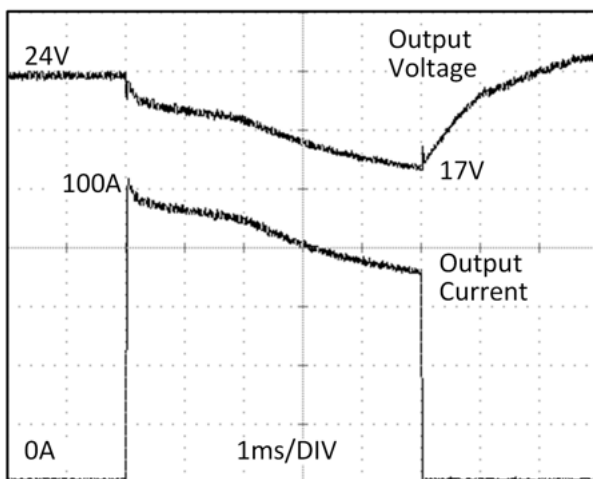

Fig. 18: 100A peak current for 5ms, typ. (5x nominal current)

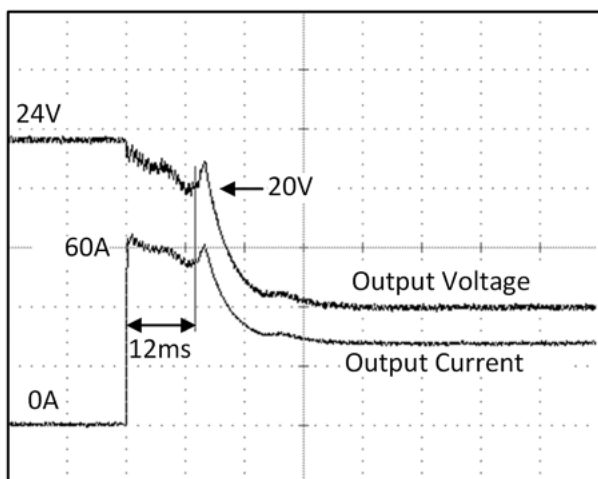

Fig. 19: 60A peak current for 12ms, typ. (3x nominal current)

● Control of DC-OK relay

i Please note: The DC-OK relay is activated if the voltage drops by more than 10% for more than 1ms.

Peak current voltage drops	
Typically from 24V to 16V	At 40A for 50ms, ohmic load
Typically from 24V to 21V	At 100A for 2ms, ohmic load
Typically from 24V to 17V	At 100A for 5ms, ohmic load

4.2 Output circuit breakers

Standard circuit breakers (or UL1077 circuit breakers) are generally used for AC supply systems and can also be used for 24V branches.

Circuit breakers are used to protect wires and circuits. If the ampere value and the characteristics of the circuit breaker are matched to the wire thickness used, the wiring is considered thermally safe, regardless of whether the circuit breaker opens or not.

To avoid voltage drops and situations with undervoltage in adjacent 24V branches fed from the same source, a fast (magnetic) trip of the circuit breaker is desirable. Fast switch-off within 10ms is required, which approximately corresponds to the bridging time of PLC. This requires power supplies with high reserve current and large output capacitors. In addition, the impedance of the faulty branch must be sufficiently small for the current to actually flow.

The following table contains typical test results that show which circuit breakers with B and C characteristics trip magnetically, depending on the wire cross-section and the wire length.

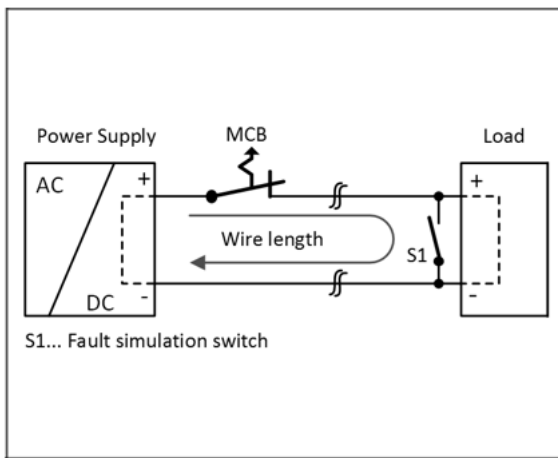

Fig. 20: Test circuit

Maximum wire length¹⁾ for fast (magnetic) tripping:

	0.75mm ²	1.0mm ²	1.5mm ²	2.5mm ²
C-2A	31 m	37 m	63 m	98 m
C-3A	28 m	34 m	51 m	78 m
C-4A	18 m	25 m	38 m	58 m
C-6A	9 m	11 m	18 m	26 m
C-8A	6 m	7 m	12 m	14 m
C-10A	4 m	6 m	11 m	13 m
C-13A	2 m	2 m	4 m	7 m

	0.75mm ²	1.0mm ²	1.5mm ²	2.5mm ²
B-6A	23 m	28 m	46 m	66 m
B-10A	11 m	14 m	19 m	32 m
B-13A	7 m	11 m	16 m	29 m
B-16A	5 m	6 m	8 m	15 m
B-20A	1 m	1 m	2 m	4 m
B-25A				1 m

¹⁾ Don't forget to double the distance to the load (or the cable length) when calculating the total cable length (plus and minus cable).

4.3 Charging batteries

The power supply can be used to charge lead-acid batteries or maintenance-free batteries (SLA or VRLA batteries). Two 12V batteries connected in series are required.

Instructions for charging batteries:

- Only use matched batteries when connecting 12V types in series.
- Make sure that the ambient temperature of the power supply remains below 40°C.
- Use a 30A or 32A circuit breaker or a decoupling diode between the power supply and the battery.
- Make sure that the output current of the power supply is below the permissible charging current of the battery.
- The reverse current to the power supply is typically 3.5mA. This reverse current can discharge the battery when the power supply is switched off, unless a decoupling diode is used.
- Switch the device to "Parallel Use" mode and adjust the output voltage, measured at no load and at the battery end of the cable, very precisely to the end-of-charge voltage.

End-of-charge voltage	27.8V	27.5V	27.15V	26.8V
Battery temperature	10°C	20°C	30°C	40°C

4.4 Series connection

Power supplies of the same type can be connected in series to increase the output voltages. As many devices can be connected in series as necessary, as long as the sum of the output voltages does not exceed 150Vdc. Voltages with a potential higher than 60Vdc are no longer regarded as safety extra-low voltage and can be dangerous. Such voltages must be protected with a touch guard.

Avoid application of return voltage (e.g. from a braking motor or battery) to the output terminals.

Restrictions: Keep a mounting distance of 15mm (left/right) between two power supplies and do not install the power supplies above each other. Power supplies connected in series should only be used in the standard installation position (terminals on the underside of the device).

Remember that leakage current, electromagnetic interference, inrush current and harmonics increase when using multiple power supplies.

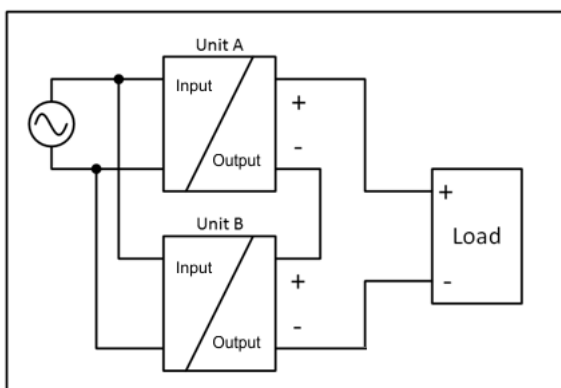

Fig. 21: Series connection

4.5 Parallel use to increase power

PS2001-2420-0000 power supplies can be connected in parallel to increase the output power. The output voltage of all power supplies must be set to the same value ($\pm 100\text{mV}$) in "Single Use" mode and with the same load conditions on all devices, or the factory settings of the devices can be retained. After making adjustments, set the unit to "Parallel Use" mode to achieve load sharing. "Parallel Use" mode regulates the output voltage so that the voltage at no load is approx. 4% higher than at nominal load. See also [Output chapter](#) [▶ 15]

The ambient temperature may not exceed $+60^{\circ}\text{C}$.

If more than three devices are connected in parallel, a fuse or circuit breaker with a rated current of 30A or 32A is required at each output. Alternatively a diode can be used.

Energize all devices simultaneously. It may also be necessary to ramp up and shut down the input power (turn off for at least five seconds) if the output was overloaded or short-circuited and the required output current is higher than the current of a device.

Restrictions: Keep a mounting distance of 15mm (left/right) between two power supplies and do not install the power supplies above each other. In parallel mode power supplies should only be used in the standard installation position (terminals on the underside of the device), not in other installation positions or under other conditions that require a reduction in the output current (e.g. installation altitude ...).

Remember that leakage current, electromagnetic interference, inrush current and harmonics increase when using multiple power supplies.

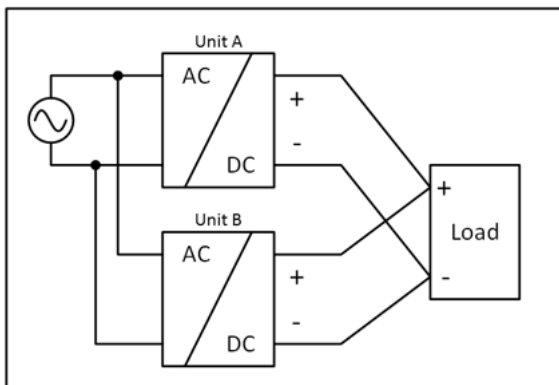

Fig. 22: Parallel connection

4.6 Parallel use for redundancy

Recommendations for the construction of redundant power supply systems:

- Power supplies that contain a DC-OK signal contact are best suited for the construction of redundant power supply systems.
 - Use this DC-OK signal contact to monitor the individual power supplies.
- Use separate grids for each power supply whenever possible.
- It is recommended to set the output voltages of all devices to the same value (± 100 mV) or to leave them at the factory setting.

4.6.1 1+1 Redundancy

It is possible to connect power supplies in parallel for redundancy operation in order to achieve better system availability. Redundant systems provide a certain amount of additional power to operate the load when a power supply unit fails. The simplest method is to connect two power supplies in parallel. This is called 1+1 redundancy. If one power supply fails, the other can automatically supply the load current without interruption.

The 1+1 redundancy allows ambient temperatures up to $+70^{\circ}\text{C}$.

i Notes on parallel use for 1+1 redundancy

- Be sure to use a redundancy module in order to decouple devices from one another. This prevents the defective device from becoming a load for the other device and the output voltage no longer being maintainable.
- Note that leakage current, EMI, input inrush current and harmonics increase when using multiple devices.

Wiring example:

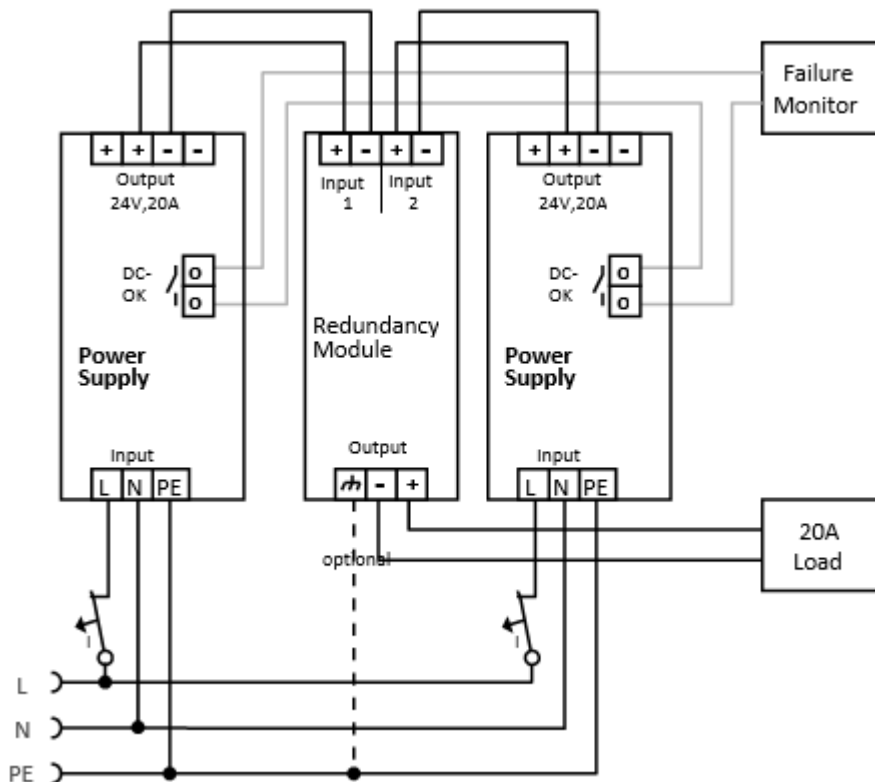

Fig. 23: Wiring for 1+1 - redundancy with one redundancy module PS9401-2440-0000

4.6.2 N+1 Redundancy

Notes on parallel use for N + 1 redundancy

- Note that leakage current, EMI, input inrush current and harmonics increase when using multiple devices.
- The ambient temperature may not exceed +60 °C for N + 1 redundancy systems.

Redundancy systems for higher power requirements are usually set up using the N + 1 method. For example, four devices with a nominal current of 20 A are connected in parallel for a 60 A redundancy system.

- Keep a mounting distance of 15 mm (left/right) between two power supplies.
- Do not install the power supplies above each other.
- Do not use power supplies connected in parallel in an installation position that deviates from the standard installation position (connection terminals on the underside of the device) or in a different state requiring a reduction in the output current.

Wiring example:

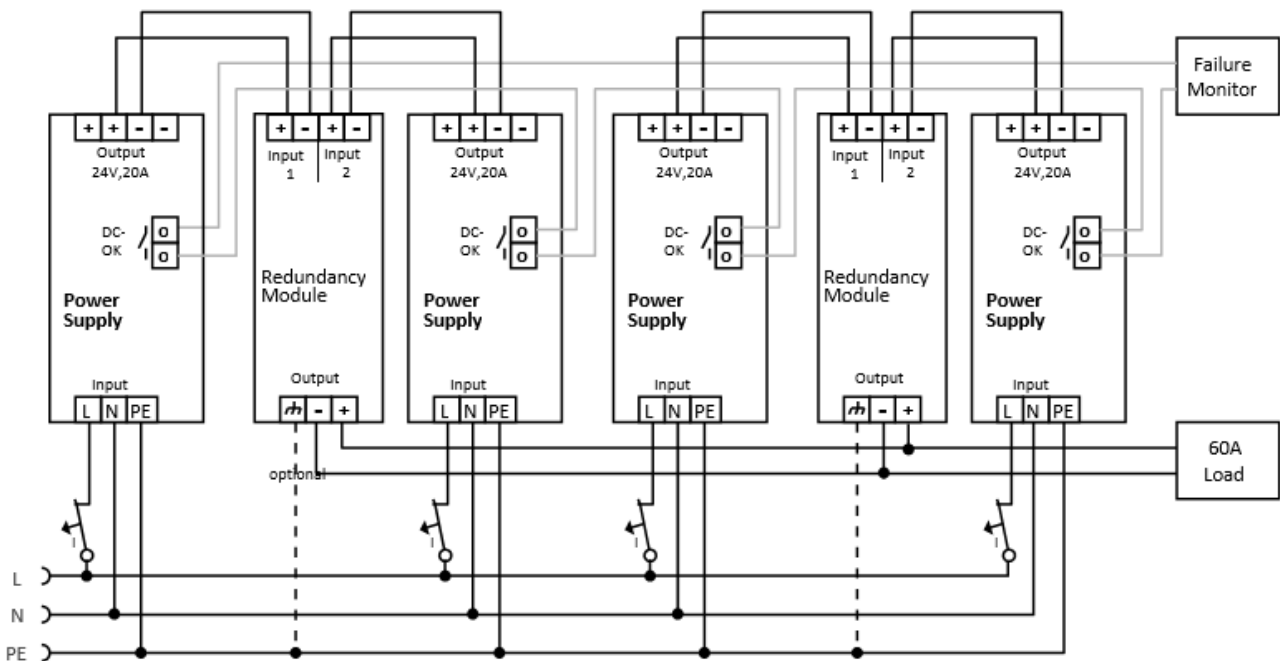

Fig. 24: Wiring for n+1 - redundancy with two redundancy modules PS9401-2440-0000

4.7 Operation on two phases

The power supply can also be used on two phases of a three-phase system. Such a phase-to-phase connection is permissible as long as the supply voltage is below $240V+10\%$.

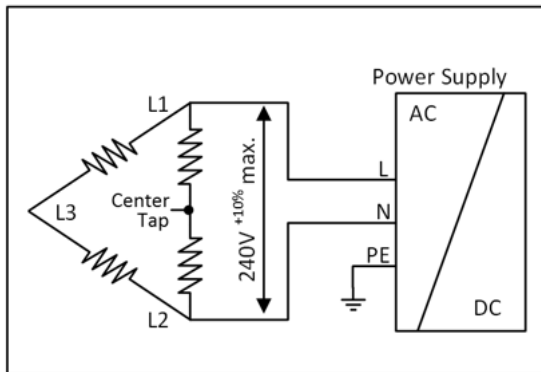

Fig. 25: Operation on two phases

Make sure that the connection cable connected to the N terminal is fused appropriately.

The maximum permissible voltage between one phase and the PE must be below 300Vac.

4.8 Use in a sealed housing

When the power supply is installed in a sealed housing, the temperature inside the housing is higher than outside. In this case, the temperature inside the housing is considered the ambient temperature for the power supply.

In the following test arrangement, the device is placed at the center of the housing, and there are no other heat-generating objects in the housing. The load is placed outside the housing.

The temperature sensor inside the housing is placed at the center of the right side of the power supply at a distance of 1 cm.

The following measurement results can be used as a reference to estimate the temperature rise within the housing.

	Case A	Case B
Housing size	180x180x165mm Rittal housing, protection class IP66 PK 9519 100, plastic	180x180x165mm Rittal housing, protection class IP66 PK 9519 100, plastic
Input voltage	230Vac	230Vac
Load	24V, 16A; (=80%)	24V, 20A; (=100%)
Temperature inside the housing	51.7°C	55.8°C
Temperature outside the housing	25.9°C	25.6°C
Temperature increase	25.8K	30.2K

4.9 Installation positions

Installation positions other than the input connections at the bottom and the output at the top require a reduction of the continuous output power or a limitation of the maximum permissible ambient temperature.

The values for service life and MTBF given in this data sheet are only valid for the standard mounting orientation.

The following curves give an indication of permissible output currents for altitudes up to 2000m.

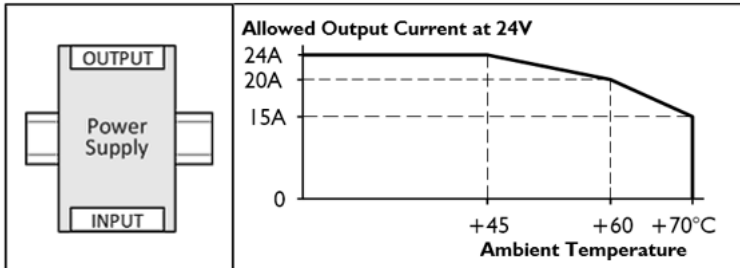

Fig. 26: Mounting position A (standard mounting position)

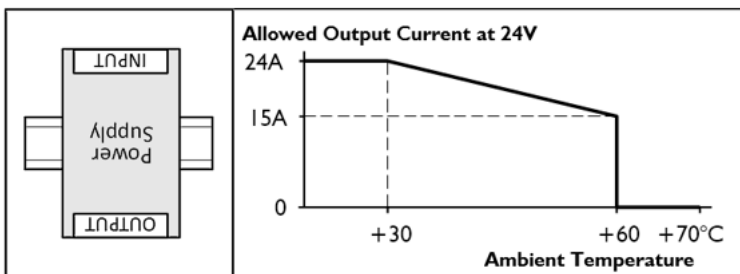

Fig. 27: Mounting position B (upside down)

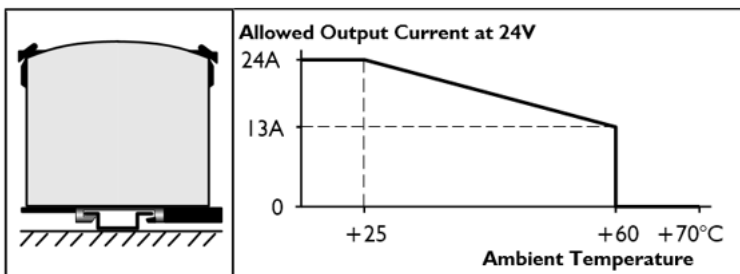

Fig. 28: Mounting position C (table mounting)

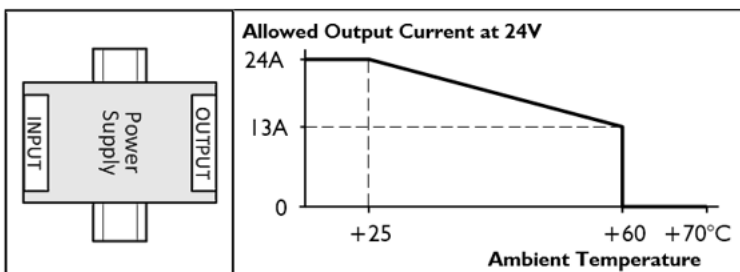

Fig. 29: Mounting position D (horizontal clockwise)

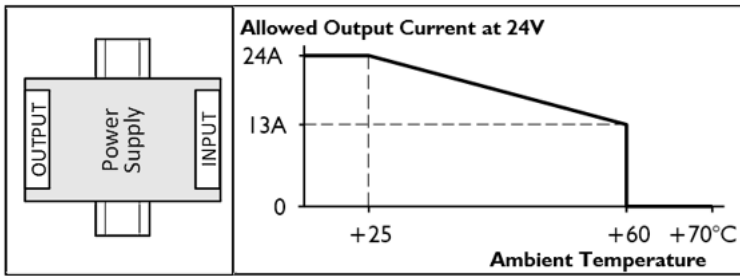

Fig. 30: Mounting position E (horizontal counterclockwise)

5 Disposal



Products marked with a crossed-out wheeled bin shall not be discarded with the normal waste stream. The device is considered as waste electrical and electronic equipment. The national regulations for the disposal of waste electrical and electronic equipment must be observed.

6 Appendix

6.1 Accessories

6.1.1 Redundancy and Buffer Modules

Power supply	Accessories		
	Redundancy module	Buffer module	UPS component
PS2001-2420-0000	PS9401-2440-0000	PS9011-2420-0001	CU8130-0xxx

PS9401-2440-0000 – Redundancy Module



The PS9401-2440-0000 is a redundancy module that can be used for the construction of 1+1 and N+1 redundancy systems.

It has two input channels, to which power supplies with output currents of up to 20 A can be connected, and one output that can carry nominal currents of up to 40 A.

The redundancy module uses MOSFET technology instead of diodes for decoupling the two input channels. This reduces the heat development and the voltage drop between input and output. Due to the low power loss, the device is very narrow and requires a width of just 36 mm on the DIN rail.

Large connection terminals enable secure and fast installation.

The redundancy module requires no additional auxiliary voltage.

Due to the international approvals package, the device is suitable for virtually every application.

Observe the connection instructions in the chapter "[Parallel use for redundancy](#) [[▶ 34](#)]"

PS9011-2420-0001 – Buffer Module



The PS9011-2420-0001 buffer module is an additional device for 24 V DC power supply units. It supplies power to bridge typical mains power failures or extends the hold-up time after switching off the AC voltage.

If the power supply unit supplies sufficient voltage, the buffer module stores energy in the integrated electrolytic capacitors. In the event of a failure of the mains voltage, the stored energy is supplied to the DC bus in a controlled process.

The buffer module can be connected at any point in parallel with the load circuit and does not require any control wiring.

A buffer module can provide 20 A of additional power and can be added in parallel to increase the output current or hold-up time.

The PS9011-2440-0000 buffer module can optionally be used to achieve longer hold-up times.

6.1.2 USV component

CU8130-0xxx – UPS component



CU8130-0xxxs are battery-backed, uninterruptible power supplies (UPS). If the external 24 V DC input voltage is lost, the UPS takes over the supply of the devices connected to it thanks to its regulated and buffered 24 V DC output voltage.

The CU81xx UPS series is suitable for all Beckhoff components, particularly Industrial PCs, Embedded PCs, Panels and Panel PCs.

The main features of this UPS are:

- battery module based on NiMH cells
- mounting of the UPS on the DIN rail or on the rear panel of the control cabinet
- protocol-based communication with the Industrial PC either via OCT (**O**ne **C**able **T**echnology) or USB
- digital signals for communication with non-protocol-capable end devices
- TwinCAT PLC function blocks for querying the UPS operation

A special feature of the Beckhoff CU81xx devices is OCT (**O**ne **C**able **T**echnology) as communication technology between UPS and Industrial PC. This means that the two connecting lines (+24 V, 0 V) between Industrial PC and UPS are used not only to supply the Industrial PC, but also for bidirectional data transmission.

If both sides are OCT-capable, no further connection, e.g., via USB, is required.

Further information on UPS components can be found on the Beckhoff [homepage](#).

6.1.3 Accessories for mounting

ZS5301-0003 – Bracket for wall mounting

This bracket is used to mount the device on a level surface or panel without the use of a DIN rail. The bracket can be mounted without loosening the DIN rail brackets.

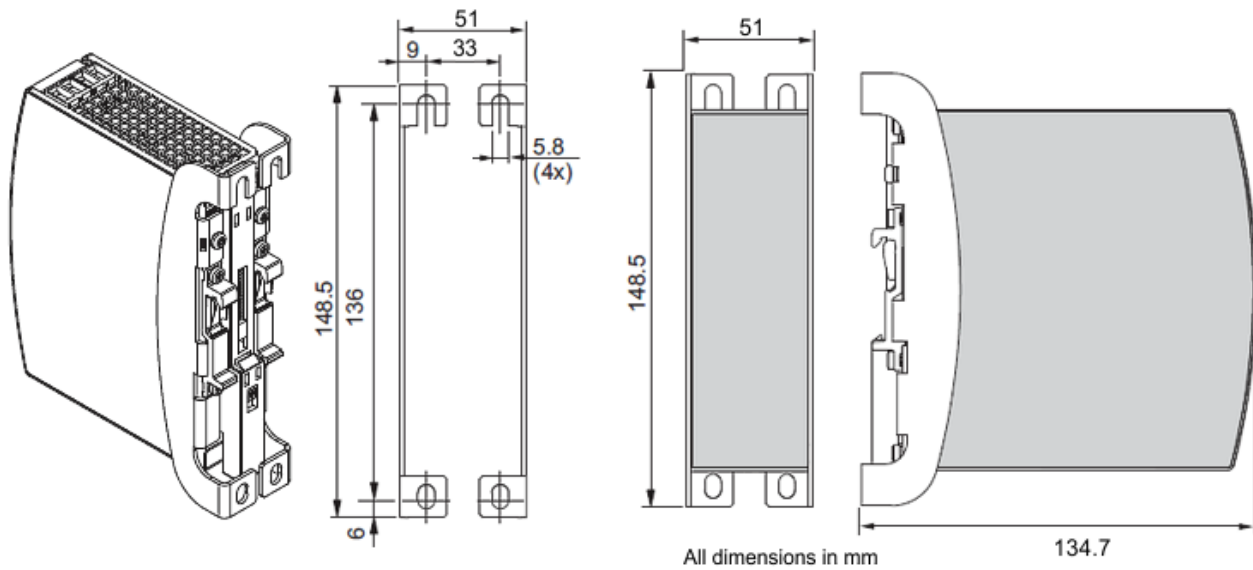

Fig. 31: Isometric view, installation dimensions bracket for wall mounting

6.2 Documentation issue status

Version	Comment
1.1	<ul style="list-style-type: none">- Chapter "Parallel use for redundancy" added- Chapter "Declaration of conformity and approvals" updated- Chapter "Accessories" updated- Chapter "Disposal" added- Update structure
1.0	<ul style="list-style-type: none">- First public issue
0.3	<ul style="list-style-type: none">- Complements, corrections
0.2	<ul style="list-style-type: none">- Complements, corrections
0.1	<ul style="list-style-type: none">- Preliminary documentation for PS2001-2420-0000

6.3 Support and Service

Beckhoff and their partners around the world offer comprehensive support and service, making available fast and competent assistance with all questions related to Beckhoff products and system solutions.

Beckhoff's branch offices and representatives

Please contact your Beckhoff branch office or representative for local support and service on Beckhoff products!

The addresses of Beckhoff's branch offices and representatives round the world can be found on her internet pages: www.beckhoff.com

You will also find further documentation for Beckhoff components there.

Support

The Beckhoff Support offers you comprehensive technical assistance, helping you not only with the application of individual Beckhoff products, but also with other, wide-ranging services:

- support
- design, programming and commissioning of complex automation systems
- and extensive training program for Beckhoff system components

Hotline: +49 5246 963 157
e-mail: support@beckhoff.com
web: www.beckhoff.com/support

Service

The Beckhoff Service Center supports you in all matters of after-sales service:

- on-site service
- repair service
- spare parts service
- hotline service

Hotline: +49 5246 963 460
e-mail: service@beckhoff.com
web: www.beckhoff.com/service

Headquarters Germany

Beckhoff Automation GmbH & Co. KG

Hülshorstweg 20
33415 Verl
Germany

Phone: +49 5246 963 0
e-mail: info@beckhoff.com
web: www.beckhoff.com

More Information:

www.beckhoff.com/ps2001-2420-0000

Beckhoff Automation GmbH & Co. KG
Hülshorstweg 20
33415 Verl
Germany
Phone: +49 5246 9630
info@beckhoff.com
www.beckhoff.com

