

Operating manual | EN

ELX3351

One channel analog input terminal for strain gauge, Ex i

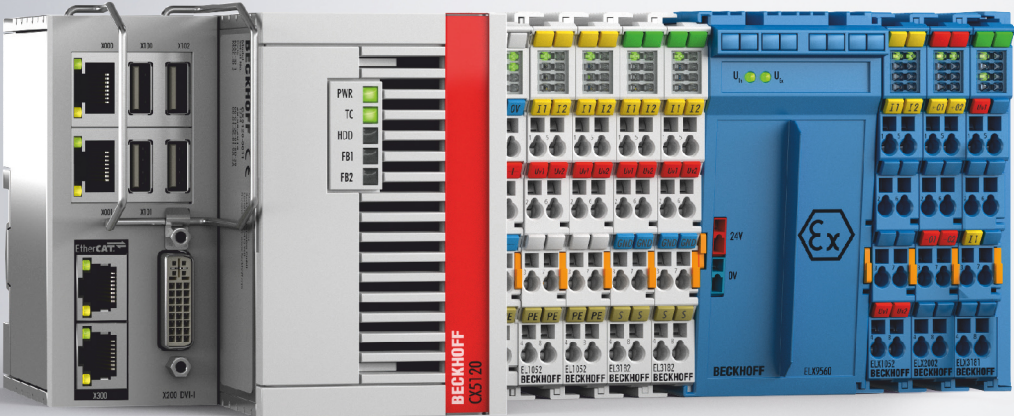

Table of contents

1 Foreword	5
1.1 Notes on the documentation	5
1.2 Safety instructions	6
1.3 Documentation Issue Status	7
1.4 Suggestions or proposals for documentation	7
1.5 Marking of ELX terminals	8
2 Product overview	12
2.1 Introduction	12
2.2 Technical data	13
2.3 Intended use	15
3 Mounting and wiring	16
3.1 Special conditions of use for ELX terminals	16
3.2 Installation notes for ELX terminals.....	16
3.3 Arrangement of ELX terminals within a bus terminal block.....	18
3.4 Installation position and minimum distances	21
3.5 Installation of ELX terminals on mounting rails	22
3.6 Disposal	23
3.7 Connection	24
3.7.1 Connection system.....	24
3.7.2 Wiring	25
3.7.3 Proper line connection	26
3.7.4 Shielding and potential separation	26
3.7.5 Contact assignment and LEDs.....	27
4 Basic function principles	30
4.1 EtherCAT basics	30
4.2 Notices on analog specifications	30
4.2.1 Full scale value (FSV).....	30
4.2.2 Measuring error/ measurement deviation	31
4.2.3 Temperature coefficient tK [ppm/K].....	31
4.2.4 Single-ended/differential typification	33
4.2.5 Common-mode voltage and reference ground (based on differential inputs).....	36
4.2.6 Dielectric strength	36
4.2.7 Temporal aspects of analog/digital conversion	37
4.3 Basic principles of strain gauge technology	40
5 Parameterization and programming	54
5.1 Basics of the measurement functions	54
5.1.1 General notes.....	54
5.1.2 Block diagram	56
5.1.3 Software filter	56
5.1.4 Dynamic filter	58
5.1.5 Calculating the weight.....	59
5.2 Application notes	59
5.2.1 Wiring fail indication	59

5.2.2	InputFreeze	59
5.2.3	Gravity adaptation	60
5.2.4	Idling recognition	61
5.2.5	Official calibration capability	61
5.3	Calibration and compensation	61
5.3.1	Sensor calibration	62
5.3.2	Self-calibration	64
5.3.3	Taring	65
5.3.4	Overview of commands	65
5.4	Process data	65
5.4.1	Selection of process data	65
5.4.2	Default process image	67
5.4.3	Variants Predefined PDO	68
5.4.4	Sync Manager	69
5.5	ELX3351 - Object description	70
5.5.1	Restore object	70
5.5.2	Configuration data	71
5.5.3	Command object	72
5.5.4	Input data	72
5.5.5	Output data	72
5.5.6	Information / diagnostic data	72
5.5.7	Standard objects	73
6	Appendix	79
6.1	EtherCAT AL Status Codes	79
6.2	UL notice	79
6.3	FM notice	80
6.4	Support and Service	81

1 Foreword

1.1 Notes on the documentation

Intended audience

This description is only intended for the use of trained specialists in control and automation engineering who are familiar with the applicable national standards.

It is essential that the documentation and the following notes and explanations are followed when installing and commissioning these components.

The qualified personnel is obliged to always use the currently valid documentation.

The responsible staff must ensure that the application or use of the products described satisfy all the requirements for safety, including all the relevant laws, regulations, guidelines and standards.

Disclaimer

The documentation has been prepared with care. The products described are, however, constantly under development.

We reserve the right to revise and change the documentation at any time and without prior announcement.

No claims for the modification of products that have already been supplied may be made on the basis of the data, diagrams and descriptions in this documentation.

Trademarks

Beckhoff®, TwinCAT®, TwinCAT/BSD®, TC/BSD®, EtherCAT®, EtherCAT G®, EtherCAT G10®, EtherCAT P®, Safety over EtherCAT®, TwinSAFE®, XFC®, XTS® and XPlanar® are registered trademarks of and licensed by Beckhoff Automation GmbH. Other designations used in this publication may be trademarks whose use by third parties for their own purposes could violate the rights of the owners.

Patent Pending

The EtherCAT Technology is covered, including but not limited to the following patent applications and patents: EP1590927, EP1789857, EP1456722, EP2137893, DE102015105702 with corresponding applications or registrations in various other countries.



EtherCAT® is registered trademark and patented technology, licensed by Beckhoff Automation GmbH, Germany.

Copyright

© Beckhoff Automation GmbH & Co. KG, Germany.

The reproduction, distribution and utilization of this document as well as the communication of its contents to others without express authorization are prohibited.

Offenders will be held liable for the payment of damages. All rights reserved in the event of the grant of a patent, utility model or design.

1.2 Safety instructions

Safety regulations

Please note the following safety instructions and explanations!
Product-specific safety instructions can be found on following pages or in the areas mounting, wiring, commissioning etc.

Exclusion of liability

All the components are supplied in particular hardware and software configurations appropriate for the application. Modifications to hardware or software configurations other than those described in the documentation are not permitted, and nullify the liability of Beckhoff Automation GmbH & Co. KG.

Personnel qualification

This description is only intended for trained specialists in control, automation and drive engineering who are familiar with the applicable national standards.

Signal words

The signal words used in the documentation are classified below. In order to prevent injury and damage to persons and property, read and follow the safety and warning notices.

Personal injury warnings

⚠ DANGER

Hazard with high risk of death or serious injury.

⚠ WARNING

Hazard with medium risk of death or serious injury.

⚠ CAUTION

There is a low-risk hazard that could result in medium or minor injury.

Warning of damage to property or environment

NOTICE

The environment, equipment, or data may be damaged.

Information on handling the product



This information includes, for example:
recommendations for action, assistance or further information on the product.

1.3 Documentation Issue Status

Version	Comment
1.6.0	<ul style="list-style-type: none"> • Chapter <i>Identification of ELX terminals</i> updated • Chapter <i>Technical data</i> updated • Chapter <i>Arrangement of ELX terminals within bus terminal block</i> extended • Chapter <i>Configuration data</i> corrected
1.5.0	<ul style="list-style-type: none"> • Technical data updated • Connection diagrams updated • Chapter <i>Disposal</i> added • Design of the safety instructions adapted to IEC 82079-1 • New title page
1.4.0	<ul style="list-style-type: none"> • FM notice regarding ANSI/ISA EX added • Chapter <i>Marking of ELX terminals</i> updated • Technical data for explosion protection extended • Chapter <i>Taring</i> updated.
1.3.1	<ul style="list-style-type: none"> • Minor corrections at chapter <i>Basic function principles</i> and <i>Parameterization and programming</i> during translation
1.3.0	<ul style="list-style-type: none"> • Chapter <i>Basic function principles</i> added • Chapter <i>Parameterization and programming</i> added
1.2.0	<ul style="list-style-type: none"> • Connection extended with sensor display • Chapter <i>Configuration of ELX terminals in Bus Terminal block</i> updated • Chapter <i>Identification of ELX terminals</i> updated • Technical data updated
1.1.0	<ul style="list-style-type: none"> • Chapter <i>Configuration of ELX terminals in Bus Terminal block</i> updated
1.0.1	<ul style="list-style-type: none"> • Layout updated
1.0	<ul style="list-style-type: none"> • Technical data updated • Chapter <i>Mounting and wiring</i> updated
0.2	<ul style="list-style-type: none"> • Technical data updated • Chapter <i>Mounting and wiring</i> updated
0.1	<ul style="list-style-type: none"> • First preliminary version (for internal use only)

1.4 Suggestions or proposals for documentation

If you have any suggestions or proposals for our documentation, please send us an e-mail stating the documentation title and version number to: documentation@beckhoff.com

1.5 Marking of ELX terminals

Designation

An ELX terminal has a 15-digit technical designation, composed of

- Family key
- Type
- Software variant
- Revision

Example	Family	Type	Software variant	Revision
ELX1052-0000-0001	ELX terminal	1052: Two-channel digital input terminal for NAMUR sensors, Ex i	0000: Basic type	0001
ELX9560-0000-0001	ELX terminal	9560: Power supply terminal	0000: Basic type	0001

Notes

- The elements mentioned above result in the **technical designation**. ELX1052-0000-0001 is used in the example below.
- Of these, ELX1052-0000 is the order identifier, commonly called just ELX1052 in the "-0000" revision. "-0001" is the EtherCAT revision.
- The **order identifier** is made up of
 - family key (ELX)
 - type (1052)
 - software version (-0000)
- The **Revision** -0001 shows the technical progress, such as the extension of features with regard to the EtherCAT communication, and is managed by Beckhoff. In principle, a device with a higher revision can replace a device with a lower revision, unless specified otherwise, e.g. in the documentation. Associated and synonymous with each revision there is usually a description (ESI, EtherCAT Slave Information) in the form of an XML file, which is available for download from the Beckhoff website. The revision has been applied to the terminals on the outside, see *Fig. ELX1052 with date code 3218FMFM, BTN 10000100 and Ex marking*.
- The hyphen is omitted in the labeling on the side of the terminal. Example:
Name: ELX1052-0000
Label: ELX1052₀₀₀₀
- The type, software version and revision are read as decimal numbers, even if they are technically saved in hexadecimal.

Identification numbers

ELX terminals have two different identification numbers:

- date code (batch number)
- **Beckhoff Traceability Number**, or BTN for short (as a serial number it clearly identifies each terminal)

Date code

The date code is an eight-digit number given by Beckhoff and printed on the ELX terminal. The date code indicates the build version in the delivery state and thus identifies an entire production batch but does not distinguish between the terminals in a batch.

Structure of the date code: **WW YY FF HH**
 WW - week of production (calendar week)
 YY - year of production
 FF - firmware version
 HH - hardware version

Example with date code 02180100:
 02 - week of production 02
 18 - year of production 2018
 01 - firmware version 01
 00 - hardware version 00

Beckhoff Traceability Number (BTN)

In addition, each ELX terminal has a unique **Beckhoff Traceability Number (BTN)**.

Ex marking

The Ex marking can be found at the top left on the terminal:

II 3 (1) G Ex ec [ia Ga] IIC T4 Gc
 II (1) D [Ex ia Da] IIIC
 I (M1) [Ex ia Ma] I
 IECEx BVS 18.0005X
 BVS 18 ATEX E 005 X

Examples

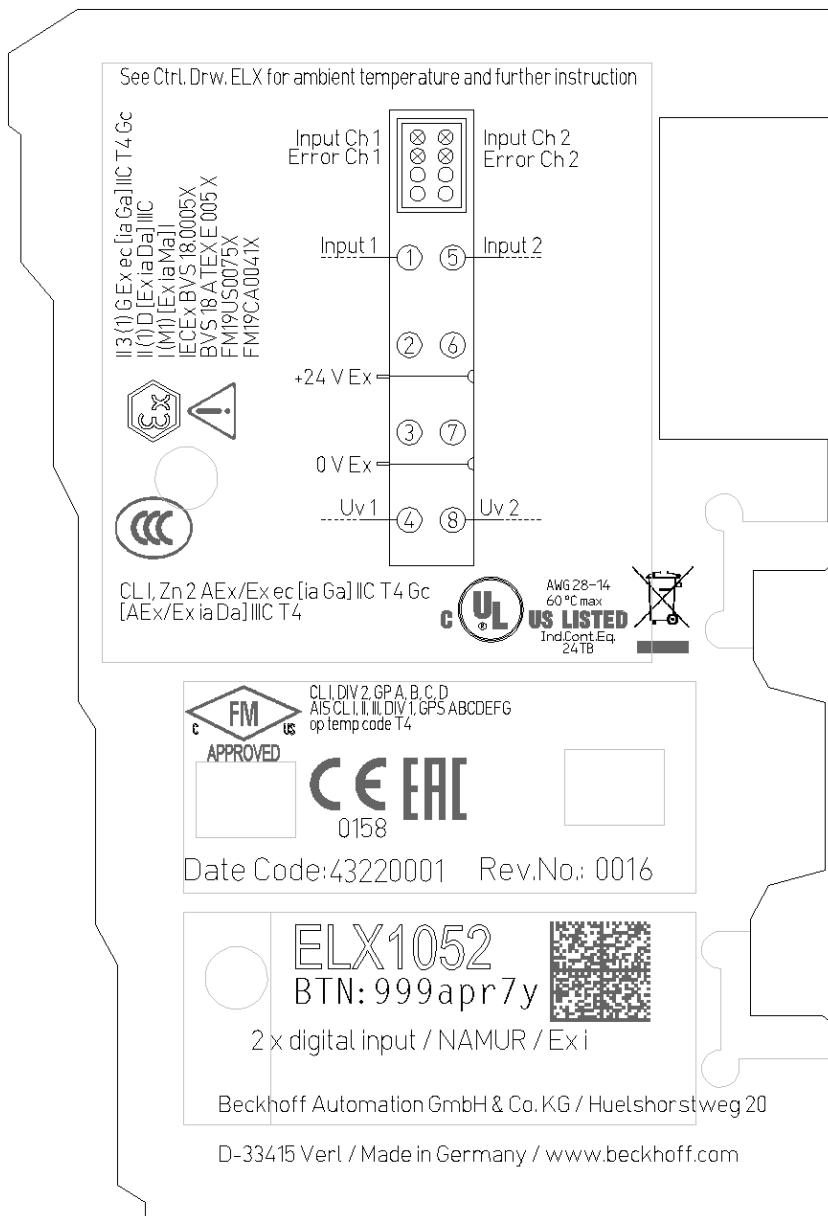

Fig. 1: ELX1052-0000 with date code 43220001, BTN 999apr7y and Ex marking



Fig. 2: ELX9560-0000 with date code 37220005, BTN 999arb1p and Ex marking

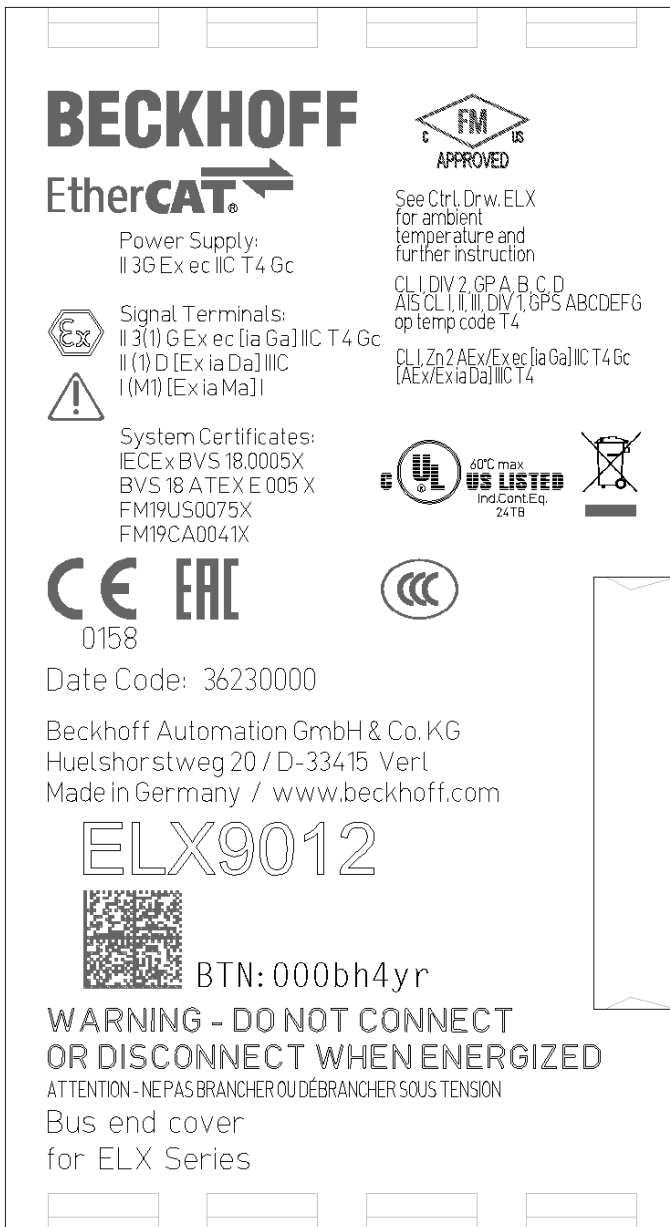

Fig. 3: ELX9012 with date code 36230000, BTN 000bh4yr and Ex marking

2 Product overview

2.1 Introduction

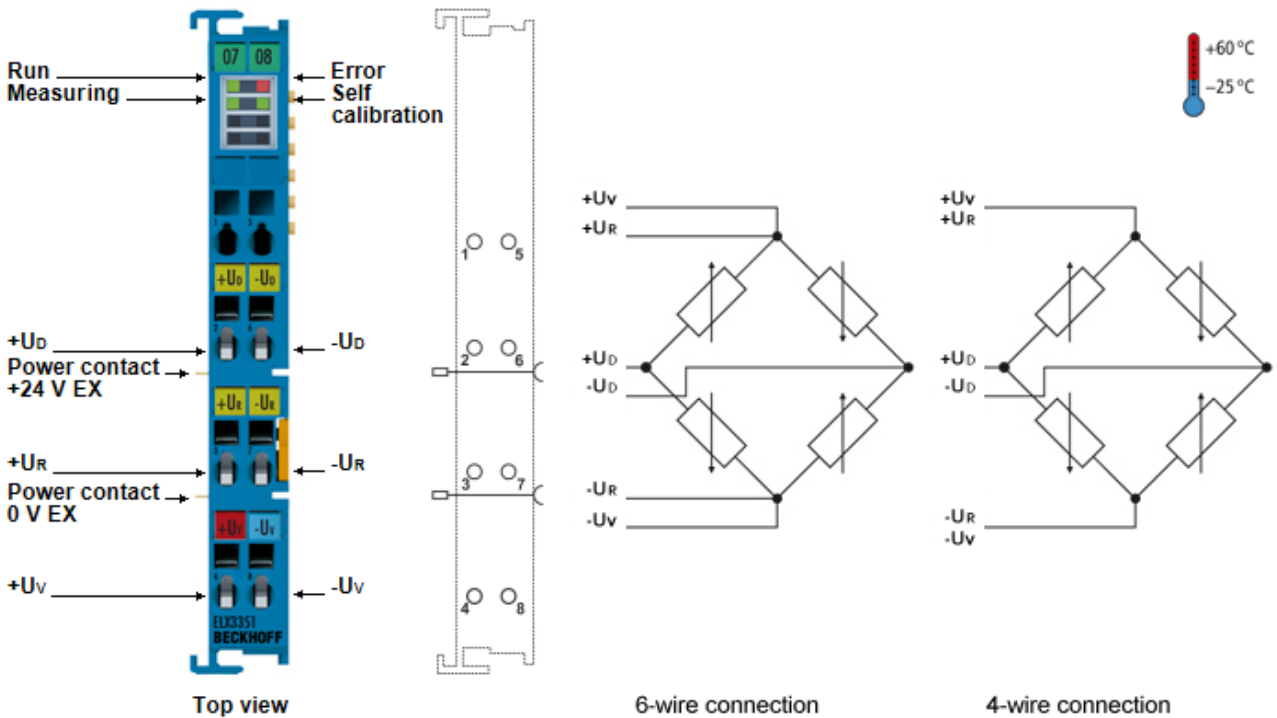

Fig. 4: ELX3351 - One channel analog input terminal for strain gauge, Ex i

The analog ELX3351 input terminal enables direct connection of a resistor bridge or load cell from hazardous areas, Zone 0/20 and 1/21. The terminal can be connected in 4- or 6-wire technology. The ratio between the bridge voltage U_D and the supply voltage U_R is determined in 24-bit resolution, and the load value is calculated as a process value. Apart from automatic self-calibration (can be deactivated), additional functions such as Tara and Freeze as well as dynamic filters are integrated.

2.2 Technical data

Technical data	ELX3351-0000
Sensor types	resistor bridge, strain gauge
Number of inputs	1, for 1 resistor bridge in full bridge technology
Connection method	4-wire, 6-wire
Bridge supply	Without exception via the connections +U _v and -U _v
Bridge input resistance	300 Ω ... 5 kΩ (from HW03)
Measuring range U _D	max. ±18 ... ±22 mV, sensor dependent (see Bridge supply voltage in case of load [► 28]) (from HW03)
Internal resistance	> 50 kΩ (U _R , differential), > 1 MΩ (U _D , differential) (from HW03)
Resolution	24 Bit, 32 bit presentation
Measuring error	±0.1% for the calculated load value referred to the load end value at a strain gauge nominal value of 2 mV/V, self-calibration active, 50 Hz filter active (from HW03)
Input filter limit frequency	typ. 3.6 kHz (-3 dB, low pass)
Conversion time	typ. 1.6 ms
Filter	50 Hz, configurable
Supply voltage electronics	via E-Bus (5 V _{DC}) and Power Contacts (24 V _{DC} Ex, feeding by ELX9560)
Current consumption from E-Bus	typ. 85 mA
Power supply U _v	up to 10 V _{DC} , sensor dependent because of internal resistors
Current consumption power contacts	min. 20 mA, dependent on sensor
Special features	self-calibration, dynamic filters, freeze
Bit width in the process image	32 bit
Electrical isolation	1500 V (E-Bus / field voltage)
Weight	app. 60 g
Permissible ambient temperature range during operation	-25°C ... + 60°C
Permissible ambient temperature range during storage	-40°C ... + 85°C
Permissible relative humidity	95%, no condensation
Permissible air pressure (operation, storage, transport)	800 hPa to 1100 hPa (this corresponds to a height of approx. -690 m to 2000 m over sea level assuming an international standard atmosphere)
Vibration / shock resistance	conforms to EN 60068-2-6 / EN 60068-2-27
EMC immunity / emission	conforms to EN 61000-6-2 / EN 61000-6-4
Protect. class	IP20
Permissible installation position	See chapter Installation position and minimum distances [► 21]
Approvals / markings*	CE, cULus, CCC, ATEX, IECEx, cFMus

*) Real applicable approvals/markings see type plate on the side (product marking).

Housing data

Technical data	ELX3351-0000
Design	compact terminal housing with signal LEDs
Material	Polycarbonate, blue
Dimensions (W x H x D)	approx. 15 mm x 100 mm x 68 mm (width aligned: 12 mm)
Installation [► 22]	on 35 mm mounting rail according to EN 60715 with locking
Stackable by	double groove-tongue connection
Labelling	Labeling of the BZxxx series
Power contacts	2 blade/spring contacts

Technical data for explosion protection

Technical data for explosion protection		ELX3351-0000	
Ex marking	ATEX	II 3 (1) G Ex ec [ia Ga] IIC T4 Gc II (1) D [Ex ia Da] IIIC I (M1) [Ex ia Ma] I	
	IECEX	Ex ec [ia Ga] IIC T4 Gc [Ex ia Da] IIIC [Ex ia Ma] I	
	cFMus	AIS Class I, II, III, Division 1, Groups A thru G Class I, Division 2, Groups A, B, C, D Class I, Zone 2, AEx/Ex ec [ia Ga] IIC T4 Gc [AEx/Ex ia Da] IIIC T4	
Certificate numbers		IECEX BVS 18.0005X BVS 18 ATEX E 005 X FM19US0075X, FM19CA0041X	
Power supply		Invariable in connection with ELX9560	
Field interfaces		U _o = 11.76 V I _o = 146 mA P _o = 214 mW Characteristic curve: linear*	
Reactance (without consideration of the simultaneousness)		L_o	C_o
	Ex ia I	20 mH	40 µF
	Ex ia IIA	13.3 mH	39 µF
	Ex ia IIB	6.6 mH	9.9 µF
	Ex ia IIC	1.7 mH	1.5 µF
	Ex ia IIIC	6.6 mH	9.9 µF

*) The values for U_o and I_o cannot occur simultaneously at the field interfaces. For the evaluation of the intrinsically safe circuit according to IEC 60079-11 and IEC 60079-25, both values should nevertheless be assumed to be present simultaneously.

2.3 Intended use

WARNING

Endangering the safety of persons and equipment!

The ELX components may only be used for the purposes described below!

CAUTION

Observe ATEX and IECEx!

The ELX components may only be used in accordance with the ATEX directive and the IECEx scheme!

The ELX terminals extend the field of application of the Beckhoff bus terminal system with functions for integrating intrinsically safe field devices from hazardous areas. The intended field of application is data acquisition and control tasks in discrete and process engineering automation, taking into account explosion protection requirements.

The ELX terminals are protected by the type of protection "Increased safety" (Ex e) according to IEC 60079-7 and must only be operated in hazardous areas of Zone 2 or in non-hazardous areas.

The field interfaces of the ELX terminals achieve explosion protection through the type of protection "intrinsic safety" (Ex i) according to IEC 60079-11. For this reason, only appropriately certified, intrinsically safe devices may be connected to the ELX terminals. Observe the maximum permissible connection values for voltages, currents and reactances. Any infringement can damage the ELX terminals and thus eliminate the explosion protection.

The ELX terminals are open, electrical equipment for installation in lockable cabinets, enclosures or operating rooms. Make sure that access to the equipment is only possible for authorized personnel.

CAUTION

Ensure traceability!

The buyer has to ensure the traceability of the device via the Beckhoff Traceability Number (BTN).

3 Mounting and wiring

3.1 Special conditions of use for ELX terminals

⚠ WARNING

Observe the special conditions of use for the intended use of Beckhoff ELX terminals in potentially explosive areas (ATEX directive 2014/34/EU)!

- The certified components are to be installed in a suitable housing that guarantees an ingress protection of at least IP54 in accordance with EN 60079-0 and EN 60529! The prescribed environmental conditions during installation, operation and maintenance are thereby to be taken into account! Inside the housing, pollution degree 1 and 2 are permissible.
- If the temperatures during rated operation are higher than 70°C at the feed-in points of cables, lines or pipes, or higher than 80°C at the wire branching points, then cables must be selected whose temperature data correspond to the actual measured temperature values!
- Observe the permissible ambient temperature range of -25 to +60°C of Beckhoff ELX terminals!
- Measures must be taken to protect against the rated operating voltage being exceeded by more than 40% due to short-term interference voltages! The power supply of the ELX9560 power supply terminal must correspond to overvoltage category II according to EN 60664-1
- The individual terminals may only be unplugged or removed from the bus terminal system if all supply voltages have been switched off or if a non-explosive atmosphere is ensured!
- The connections of the ELX9560 power supply terminal may only be connected or disconnected if all supply voltages have been switched off or if a non-explosive atmosphere is ensured!
- Address selectors and switches may only be adjusted if all supply voltages have been switched off or if a non-explosive atmosphere is ensured!

3.2 Installation notes for ELX terminals

NOTICE

Storage, transport and mounting

- Transport and storage are permitted only in the original packaging!
- Store in a dry place, free from vibrations.
- A brand new ELX terminal with a certified build version is delivered only in a sealed carton. Therefore, check that the carton and all seals are intact before unpacking.
- Do not use the ELX terminal if
 - its packaging is damaged
 - the terminal is visibly damaged or
 - you cannot be sure of the origin of the terminal.
- ELX terminals with a damaged packaging seal are regarded as used.

⚠ WARNING

Observe the accident prevention regulations

During mounting, commissioning, operation and maintenance, adhere to the safety regulations, accident prevention regulations and general technical rules applicable to your devices, machines and plants.

⚠ CAUTION

Observe the erection regulations

Observe the applicable erection regulations.

NOTICE**Protect the terminals against electrostatic discharge (ESD)**

Electronic components can be destroyed by electrostatic discharge. Therefore, take the safety measures to protect against electrostatic discharge as described in DIN EN 61340-5-1 among others. In conjunction with this, ensure that the personnel and surroundings are suitably earthed.

NOTICE**Do not place terminals on E-bus contacts**

Do not place the ELX terminals on the E-bus contacts located on the right-hand side. The function of the E-bus contacts can be negatively affected by damage caused by this, e.g. scratches.

NOTICE**Protect the terminals against dirt**

To ensure the functionality of the ELX terminals they must be protected against dirt, especially on the contact points. For this reason use only clean tools and materials.

NOTICE**Handling**

- It is forbidden to insert conductive or non-conductive objects of any kind into the interior of the housing (e.g. through the ventilation slots in the housing).
- Use only the openings provided in the housing front and appropriate tools to actuate the spring-loaded terminal contacts on the front side for attaching connection cables to the terminal; see chapter [Wiring](#) [▶ 25].
- The opening of the housing, the removal of parts and any mechanical deformation or machining of an ELX terminal are not permitted!

If an ELX terminal is defective or damaged it must be replaced by an equivalent terminal. Do not carry out any repairs to the devices. For safety reasons repairs may only be carried out by the manufacturer.

NOTICE**Contact marking and pin assignment**

The colored inscription labels above the front connection contacts shown in the illustrations in the introduction chapter are only examples and are not part of the scope of delivery!

A clear assignment of channel and terminal designation according to the chapter contact assignment to the actual terminal point can be made via the lasered channel numbers 1 to 8 on the left above the respective terminal point as well as via the laser image.

Observe any possible polarity dependency of connected intrinsically safe circuits!

3.3 Arrangement of ELX terminals within a bus terminal block

⚠ WARNING

Observe the following notes on the arrangement of ELX terminals!

- ELX signal terminals may only be mounted behind an ELX9560 power supply terminal without exception!
- Only signal terminals from the ELX series may be installed behind an ELX9560 power supply terminal!
- Several ELX9560 power supply terminals may be set in a terminal block as long as an ELX9410 is set before each additional ELX9560!
- An ELX9410 power supply terminal must not be mounted to the right of an ELX9560 or to the left of an ELX signal terminal!
- The last terminal of each ELX terminal segment must be covered with an ELX9012 bus cap or an EK1110 EtherCAT extension, unless two ELX9410 power supply terminals are installed directly behind each other in order to continue the terminal segment with standard Beckhoff EtherCAT Terminals (e.g. EL/ES/EK)!

Examples for the arrangement of ELX terminals

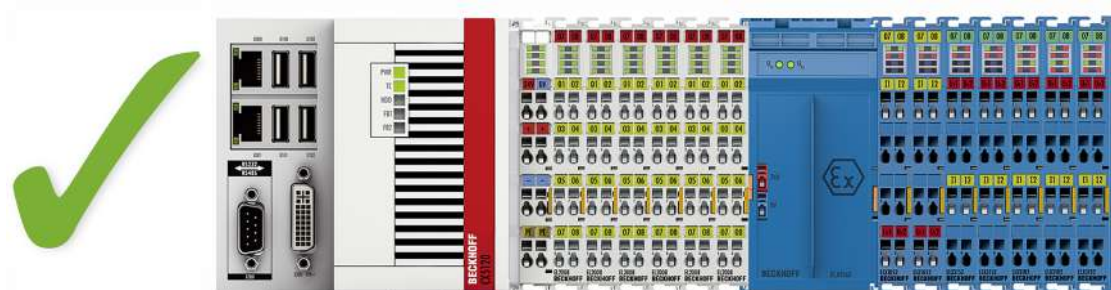

Fig. 5: Permissible arrangement of the ELX terminals (right terminal block).

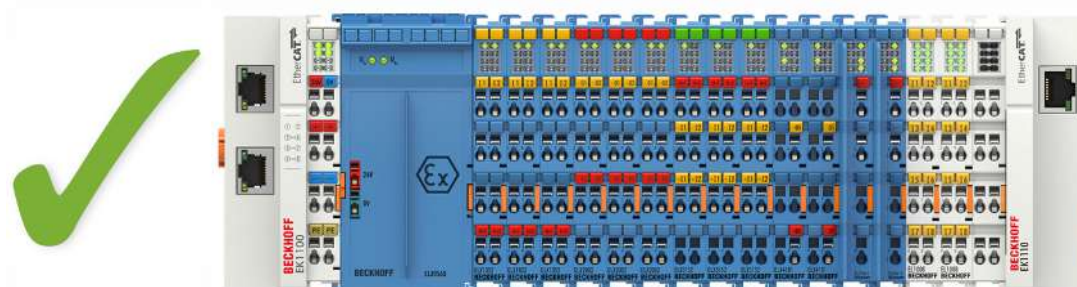

Fig. 6: Permitted arrangement - terminals that do not belong to the ELX series are placed before and after the ELX terminal segment. Isolation is provided by the ELX9560 at the beginning of the ELX terminal segment and two ELX9410 at the end of the ELX terminal segment.

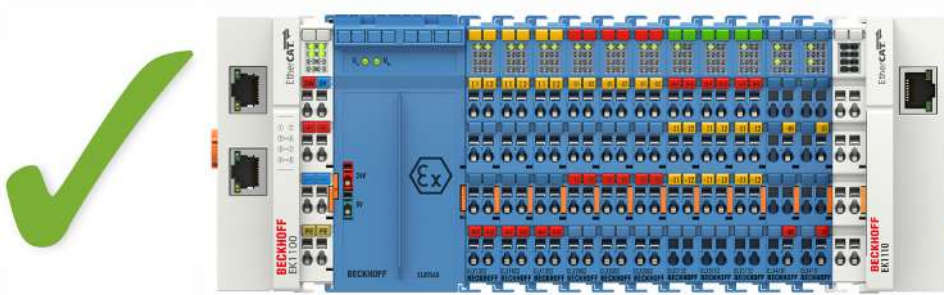

Fig. 7: Permitted arrangement - terminals that do not belong to the ELX series are placed before and after the ELX terminal segment. Isolation is provided by the ELX9560 at the beginning of the ELX terminal segment and the EK1110 at the end of the ELX terminal segment.

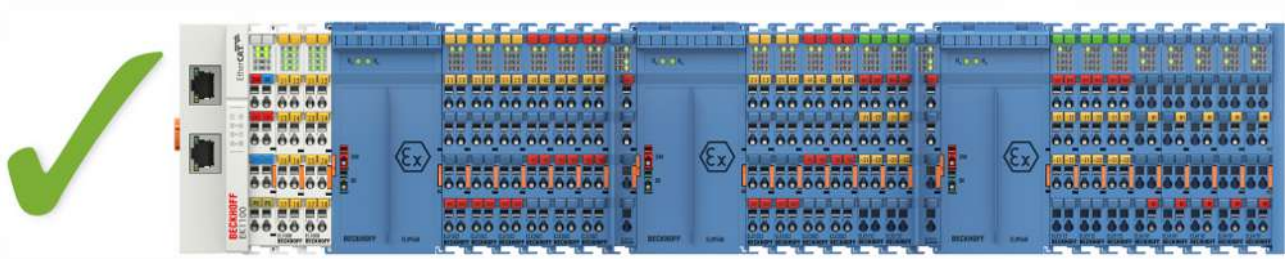

Fig. 8: Permitted arrangement - multiple resupplies by ELX9560 with an upstream ELX9410 in each case.



Fig. 9: Permitted arrangement - ELX9410 in front of an ELX9560 power supply terminal.

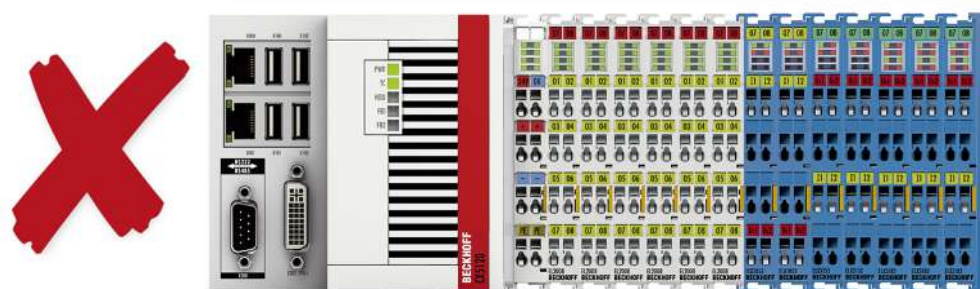

Fig. 10: Illegal arrangement - missing ELX9560 power supply terminal.

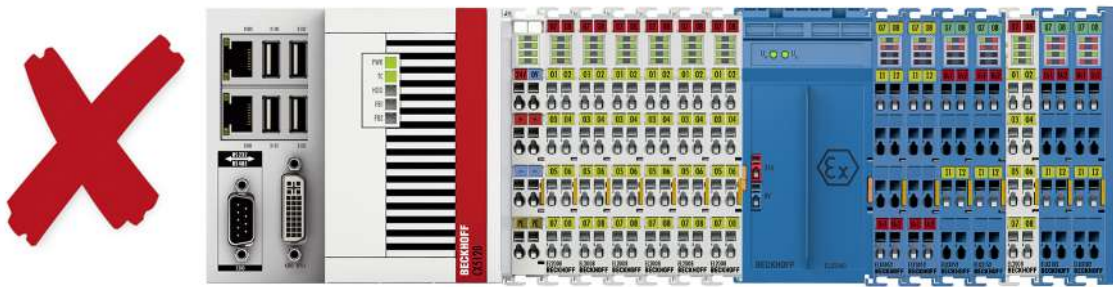

Fig. 11: Impermissible arrangement - terminal in the ELX terminal segment that does not belong to the ELX series

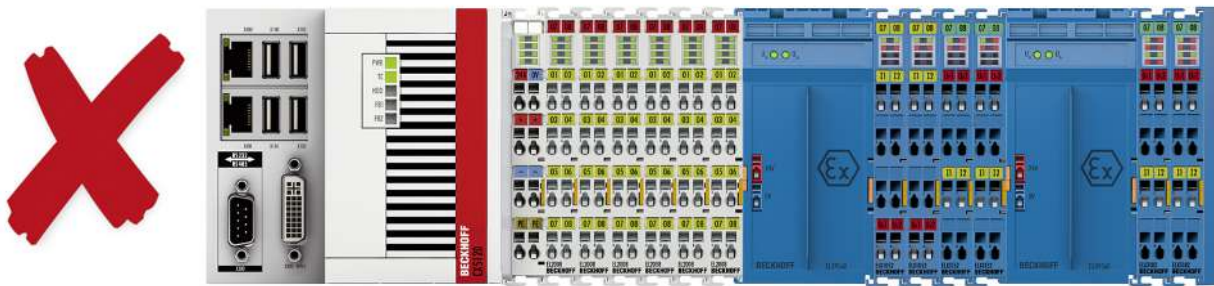

Fig. 12: Impermissible arrangement - second ELX9560 power supply terminal in the ELX terminal segment without upstream ELX9410.

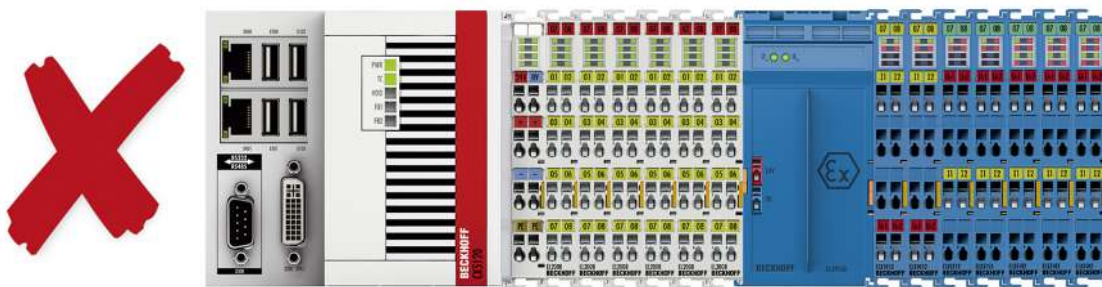

Fig. 13: Illegal arrangement - missing ELX9012 bus end cap.

NOTICE

Note the maximum output current of the ELX9560

When configuring the terminal segment, please observe the maximum available output current of the ELX9560 power supply terminal according to the specified technical data.

If necessary, an additional ELX9560 power supply terminal with upstream ELX9410 (see installation examples) must be installed or a completely new bus terminal block must be configured.

3.4 Installation position and minimum distances

Installation position

For the prescribed installation position the mounting rail is installed horizontally and the mating surfaces of the ELX terminals point toward the front (see illustration below). The terminals are ventilated from below, which enables optimum cooling of the electronics through convection. The direction indication “down” corresponds to the direction of positive acceleration due to gravity.

Minimum distances

Observe the following minimum distances to ensure optimum convection cooling:

- above and below the ELX terminals: 35 mm (required!)
- besides the bus terminal block: 20 mm (recommended)

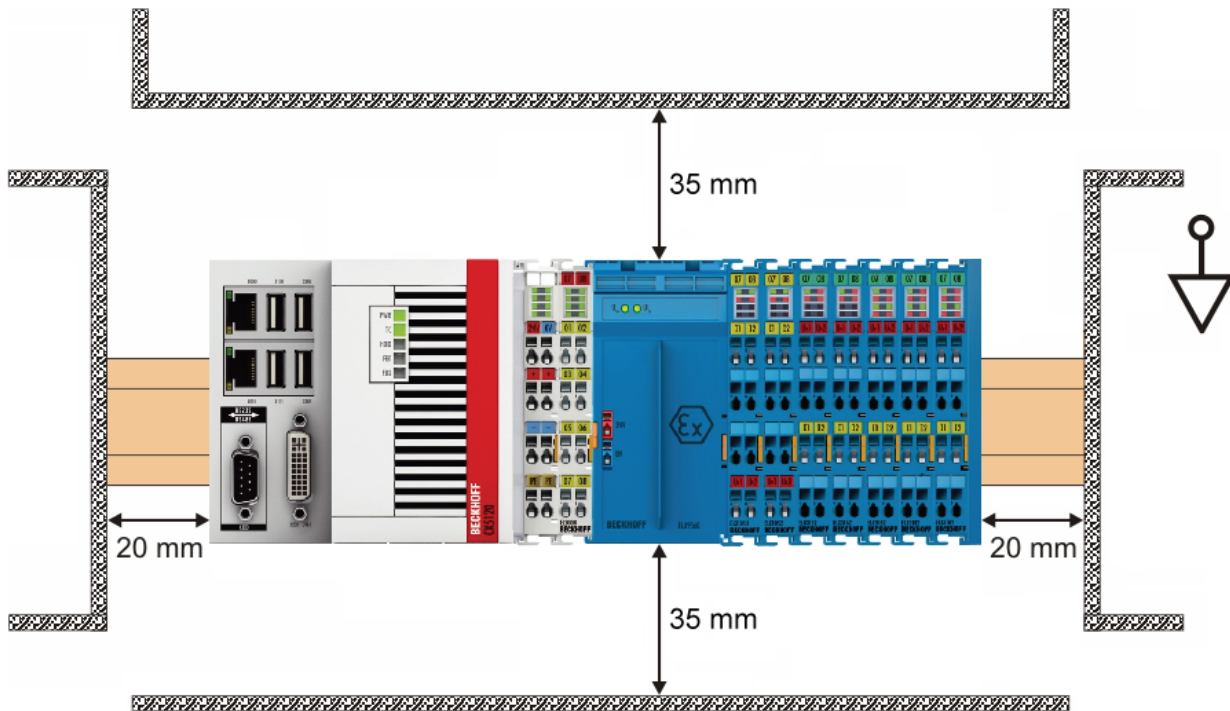

Fig. 14: Installation position and minimum distances

⚠ WARNING

Observe the minimum separation distances according to IEC 60079-14!

Observe the prescribed minimum separation distances between intrinsically safe and non-intrinsically safe circuits according to IEC 60079-14.

3.5 Installation of ELX terminals on mounting rails

⚠ WARNING

Risk of electric shock and damage of device!

Bring the bus terminal system into a safe, powered down state before starting installation, disassembly or wiring of the bus terminals!

⚠ CAUTION

Danger of injury due to power contacts!

For your own protection, pay attention to careful and careful handling of the ELX terminals. In particular, the left side mounted, sharp-edged blade contacts pose a potential risk of injury.

Assembly

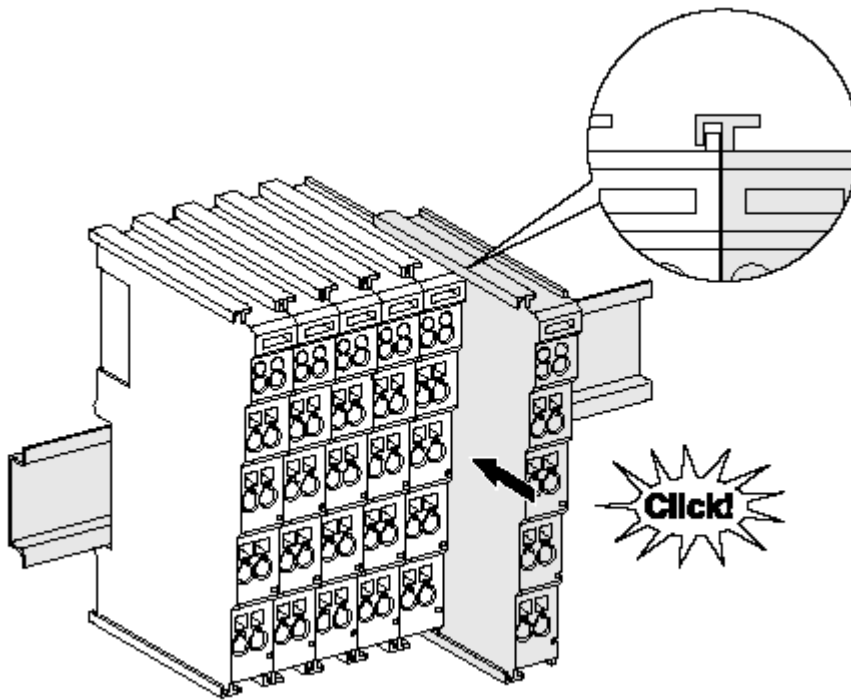

Fig. 15: Attaching on mounting rail

The bus coupler and bus terminals are attached to commercially available 35 mm mounting rails (DIN rails according to EN 60715) by applying slight pressure:

1. First attach the fieldbus coupler to the mounting rail.
2. The bus terminals are now attached on the right-hand side of the fieldbus coupler. Join the components with tongue and groove and push the terminals against the mounting rail, until the lock clicks onto the mounting rail.

If the terminals are clipped onto the mounting rail first and then pushed together without tongue and groove, the connection will not be operational! When correctly assembled, no significant gap should be visible between the housings.

● Fixing of mounting rails

i The locking mechanism of the terminals and couplers extends to the profile of the mounting rail. At the installation, the locking mechanism of the components must not come into conflict with the fixing bolts of the mounting rail. To mount the mounting rails with a height of 7.5 mm under the terminals and couplers, you should use flat mounting connections (e.g. countersunk screws or blind rivets).

Disassembly

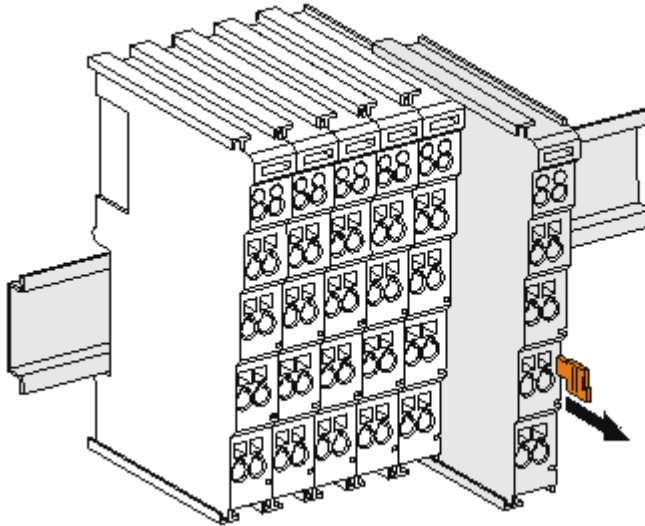

Fig. 16: Disassembling of terminal

Each terminal is secured by a lock on the mounting rail, which must be released for disassembly:

1. Pull the terminal by its orange-colored lugs approximately 1 cm away from the mounting rail. In doing so for this terminal the mounting rail lock is released automatically and you can pull the terminal out of the bus terminal block easily without excessive force.
2. Grasp the released terminal with thumb and index finger simultaneous at the upper and lower grooved housing surfaces and pull the terminal out of the bus terminal block.

Connections within a bus terminal block

The electric connections between the Bus Coupler and the Bus Terminals are automatically realized by joining the components:

- The six spring contacts of the E-Bus deal with the transfer of the data and the supply of the Bus Terminal electronics.
- The power contacts deal with the supply for the field electronics and thus represent a supply rail within the bus terminal block.
The power contacts of the ELX terminals are supplied by the ELX9560 power terminal. This interrupts the power contacts and thus represents the beginning of a new supply rail.

● Power Contacts

i During the design of a bus terminal block, the pin assignment of the individual Bus Terminals must be taken account of, since some types (e.g. analog Bus Terminals or digital 4-channel Bus Terminals) do not or not fully loop through the power contacts.

3.6 Disposal



Products marked with a crossed-out wheeled bin shall not be discarded with the normal waste stream. The device is considered as waste electrical and electronic equipment. The national regulations for the disposal of waste electrical and electronic equipment must be observed.

3.7 Connection

3.7.1 Connection system

⚠ WARNING

Risk of electric shock and damage of device!

Bring the bus terminal system into a safe, powered down state before starting installation, disassembly or wiring of the bus terminals!

The terminals of ELXxxxx series include electronics and connection level in a single enclosure.

Standard wiring



Fig. 17: Standard wiring

The terminals of ELXxxxx series feature integrated screwless spring force technology for fast and simple assembly.

High Density Terminals (HD Terminals)



Fig. 18: High Density Terminals

The Bus Terminals from these series with 16 connection points are distinguished by a particularly compact design, as the packaging density is twice as large as that of the standard 12 mm Bus Terminals. Massive conductors and conductors with a wire end sleeve can be inserted directly into the spring loaded terminal point without tools.

Ultrasonically "bonded" (ultrasonically welded) conductors

i Ultrasonically "bonded" conductors

It is also possible to connect the Standard and High Density Terminals with ultrasonically "bonded" (ultrasonically welded) conductors. In this case, please note the tables concerning the wire-size width below!

3.7.2 Wiring

⚠ WARNING

Risk of electric shock and damage of device!

Bring the bus terminal system into a safe, powered down state before starting installation, disassembly or wiring of the bus terminals!

Terminals for standard wiring

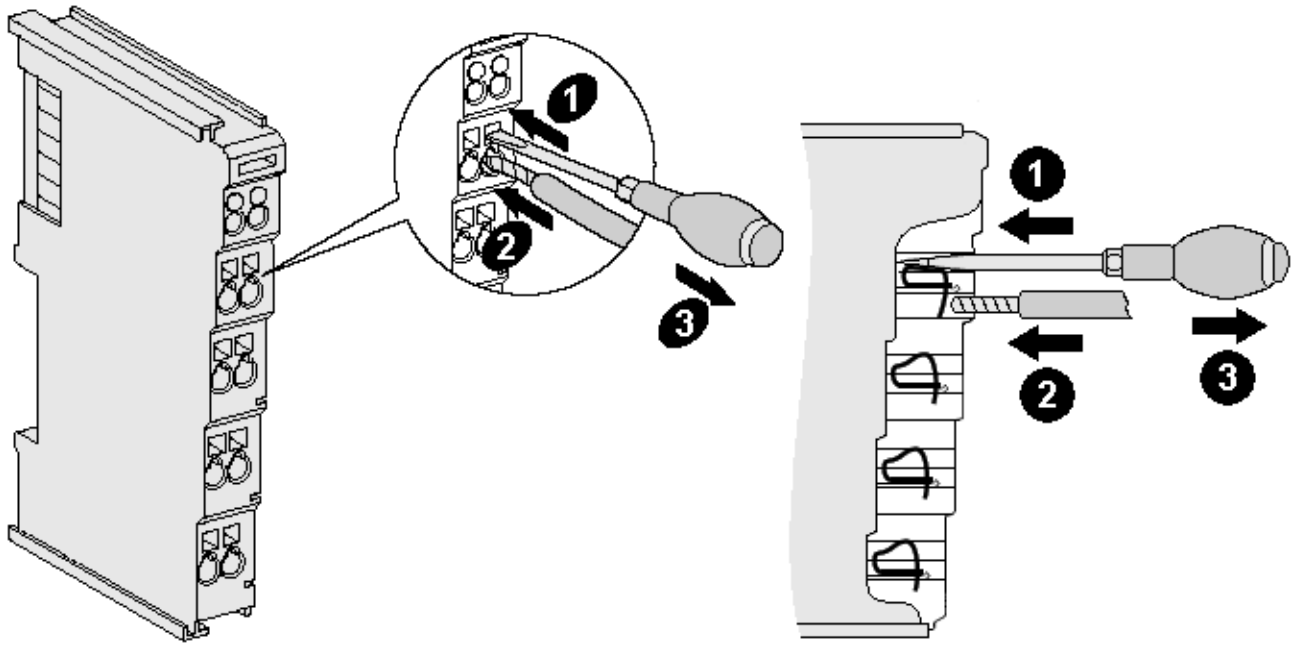

Fig. 19: Connecting a cable on a terminal point

Up to eight terminal points enable the connection of solid or finely stranded cables to the Bus Terminal. The terminal points are implemented in spring force technology. Connect the cables as follows:

1. Open a terminal point by pushing a screwdriver straight against the stop into the square opening above the terminal point. Do not turn the screwdriver or move it alternately (don't toggle).
2. The wire can now be inserted into the round terminal opening without any force.
3. The terminal point closes automatically when the pressure is released, holding the wire securely and permanently.

Observe the requirements for connecting cables and cross sections according to IEC 60079-7 and IEC 60079-11. See the following tables for the suitable wire size width.

Terminal housing	Standard wiring	ELX9560
Wire size width (single core wires)	0.08 ... 2.5 mm ²	0.14 ... 1.5 mm ²
Wire size width (fine-wire conductors)	0.08 ... 2.5 mm ²	0.14 ... 1.5 mm ²
Wire size width (conductors with a wire end sleeve)	0.14 ... 1.5 mm ²	0.14 ... 1.0 mm ²
Wire stripping length	8 ... 9 mm	8 ... 9 mm

NOTICE

Maximum screwdriver width for ELX9560

Use a screwdriver with a maximum width of 2 mm to wire the ELX9560 power supply terminal. Wider screwdrivers can damage the terminal points.

High Density Terminals (HD Terminals) with 16 terminal points

The conductors of the HD Terminals are connected without tools for single-wire conductors using the direct plug-in technique, i.e. after stripping the wire is simply plugged into the terminal point. The cables are released, as usual, using the contact release with the aid of a screwdriver. See the following table for the suitable wire size width.

Terminal housing	High Density Housing
Wire size width (single core wires)	0.08 ... 1.5 mm ²
Wire size width (fine-wire conductors)	0.25 ... 1.5 mm ²
Wire size width (conductors with a wire end sleeve)	0.14 ... 0.75 mm ²
Wire size width (ultrasonically "bonded" conductors)	only 1.5 mm ²
Wire stripping length	8 ... 9 mm

3.7.3 Proper line connection

Always connect only one wire per terminal point.

When using fine-wire conductors it is recommended to connect them with wire end sleeves in order to establish a safe, conductive connection.

In addition, make sure that the pin assignment is correct to prevent damage to the ELX terminals and the connected devices.

3.7.4 Shielding and potential separation



Shielding

Encoder, analog sensors and actors should always be connected with shielded, twisted paired wires!

CAUTION

Observe installation requirements in areas of potentially explosive atmospheres!

During installation, observe the requirements for cables, shielding and earth potential equalization in areas of potentially explosive atmospheres according to IEC 60079-11, IEC 60079-14 and IEC 60079-25!

WARNING

Ensure potential separation of the 24 V Ex busbar!

In any case, make sure that the galvanic isolation made by the ELX9560 between the 24 V Ex busbar (power contacts +24 V Ex and 0 V Ex) and other system potentials (if applicable also functional or protective earths) is not removed!

3.7.5 Contact assignment and LEDs

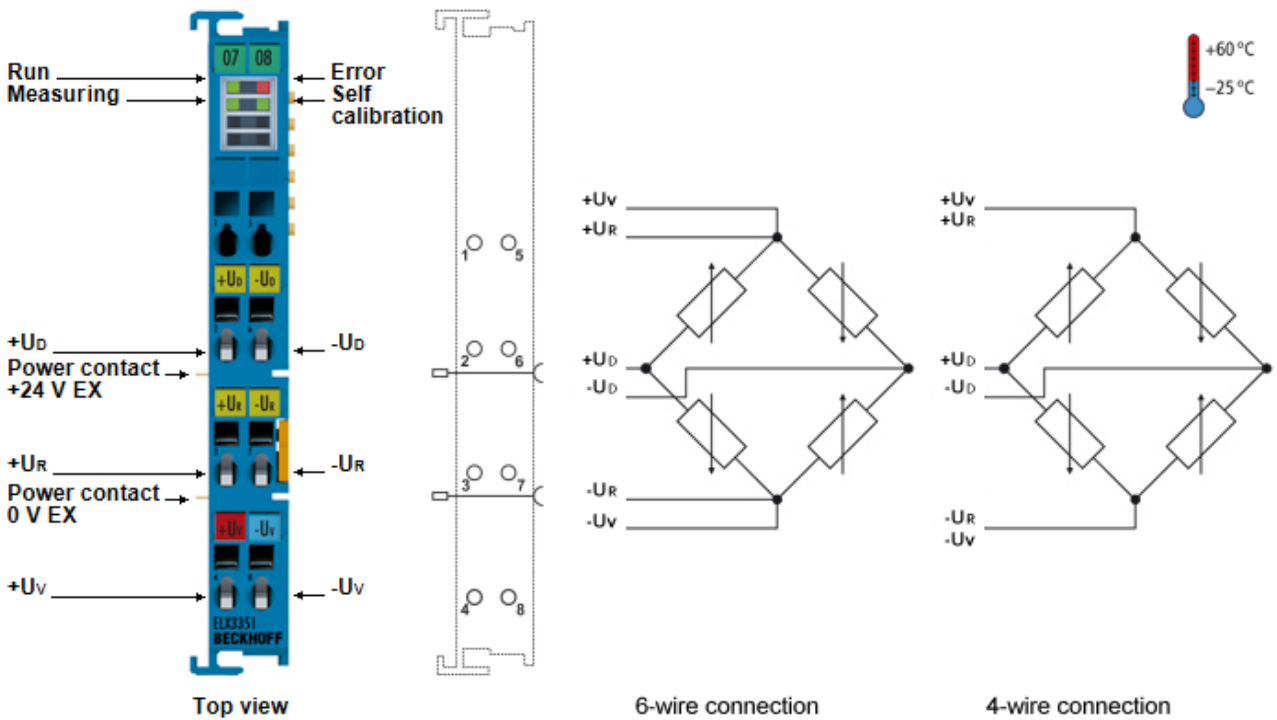

Fig. 20: ELX3351 - Contact assignment and LEDs

Terminal point		Description
Name	No.	
	1	not implemented
+U _D	2	+ input measuring voltage (difference voltage of bridge)
+ U _R	3	+ input reference voltage (supply voltage at bridge)
+U _V	4	+ output supply voltage for bridge
	5	not implemented
-U _D	6	- input measuring voltage (difference voltage of bridge)
- U _R	7	- input reference voltage (supply voltage at bridge)
- U _V	8	- output supply voltage for bridge

Wiring the bridge

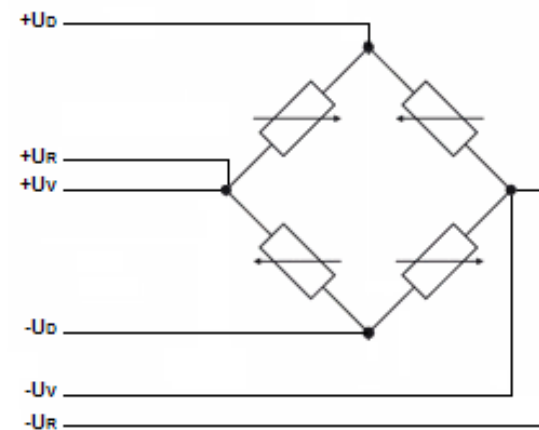

Fig. 21: ELX3351 - Connection of a full bridge in 6-wire technology

The ELX3351 is standardly designed for a sensor connection in 6-wire technology. In the event that a sensor is to be operated in 4-wire technology, the contacts $+U_V$ and $+U_R$ as well as the contacts $-U_V$ and $-U_R$ are to be bridged manually, a software-side switching within the terminal is not possible.

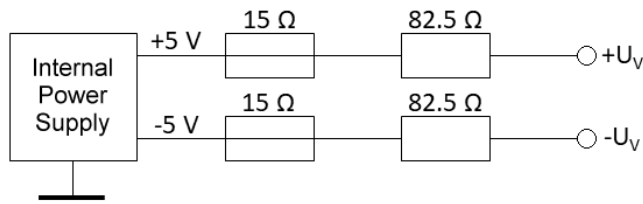

Fig. 22: ELX3351 - Power supply

The terminal supplies 10 V_{DC} bridge supply voltage U_V in not loaded state. This voltage is still limited to U_O in accordance with the [Technical Data for Explosion Protection \[► 14\]](#).

Bridge supply voltage in case of load

Due to the explosion protection measures in the circuit, the bridge supply voltage is reduced in case of load.

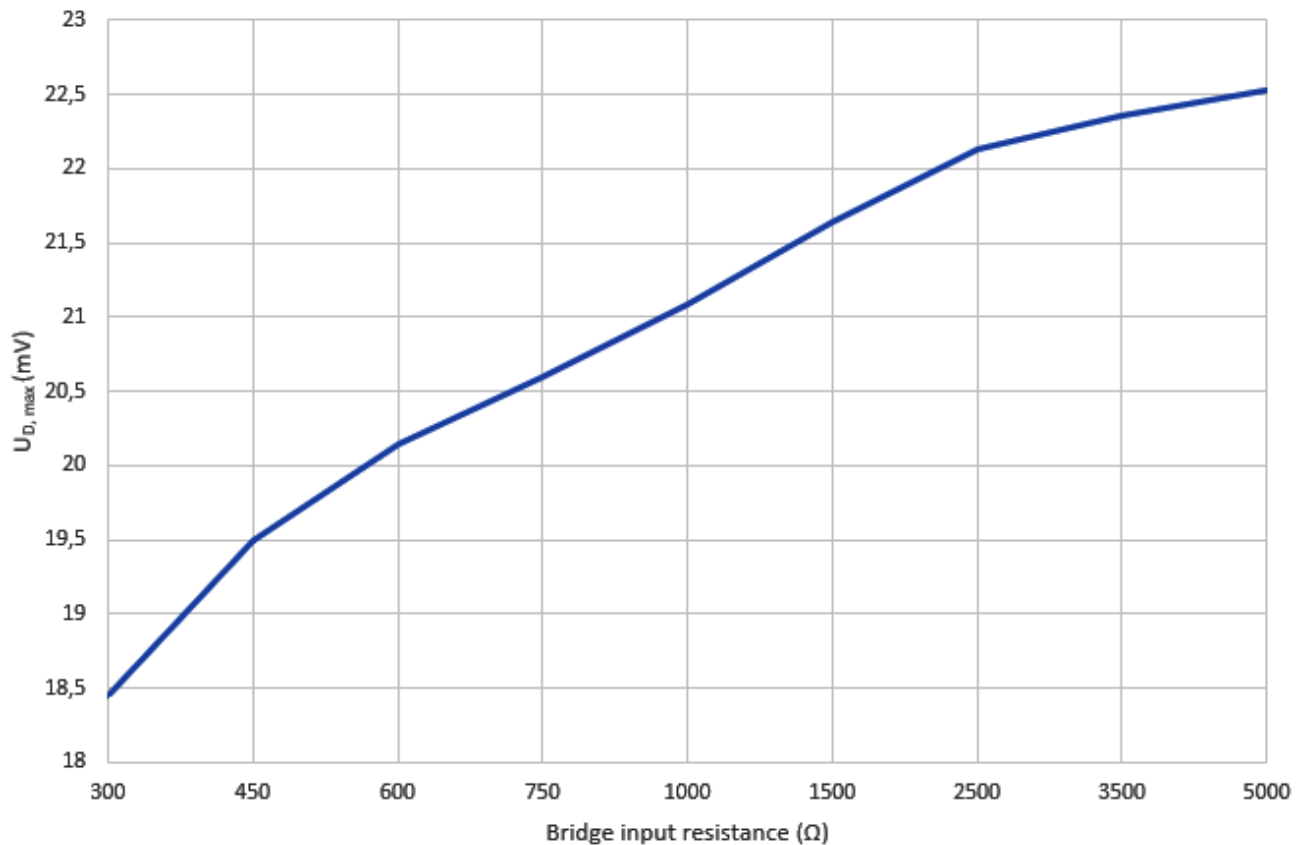

Fig. 23: ELX3351 - Measuring range U_D as a function of the bridge input resistance

LED Display

LED	Color	Meaning	
Run	green	These LED indicates the terminal's operating state:	
		off	State of the EtherCAT State Machine: INIT = initialization of the terminal
		flashing	State of the EtherCAT State Machine: PREOP = function for mailbox communication and different standard-settings set
		single flash	State of the EtherCAT State Machine: SAFEOP = verification of the Sync Manager channels and the distributed clocks. Outputs remain in safe state
		on	State of the EtherCAT State Machine: OP = normal operating state; mailbox and process data communication is possible
		flickering	State of the EtherCAT State Machine: BOOTSTRAP = function for firmware updates of the terminal
Error	red	on	There is a fault (eg. undershooting or exceeding the measured value range) Note: Wire break detection is only for the +Uv and -Uv connections
Measuring	green	on	The terminal is in normal operating mode (measurement)
Self calibration	green	on	Self-calibration in operation

4 Basic function principles

4.1 EtherCAT basics

For basic information about the EtherCAT fieldbus please refer to the [EtherCAT system documentation](#), which is also available as [PDF file](#) at www.beckhoff.com in the download area of your EtherCAT device.

4.2 Notices on analog specifications

Beckhoff I/O devices (terminals, boxes, modules) with analog inputs are characterized by a number of technical characteristic data; refer to the technical data in the respective documents.

Some explanations are given below for the correct interpretation of these characteristic data.

4.2.1 Full scale value (FSV)

An I/O device with analog input measures over a nominal measuring range, which is limited by an upper and a lower limit (start value and end value), which can usually already be taken from the device designation. The range between both limits is called measuring span and corresponds to the formula (end value - start value). Analogous to pointing devices this is the measuring scale (see IEC 61131) or also the dynamic range.

For analog I/O devices from Beckhoff, the full scale value (FSV) of the respective product (also: reference value) is selected as the largest limit of the nominal measuring range and is given a positive sign. This applies to both symmetrical and asymmetrical measuring spans.

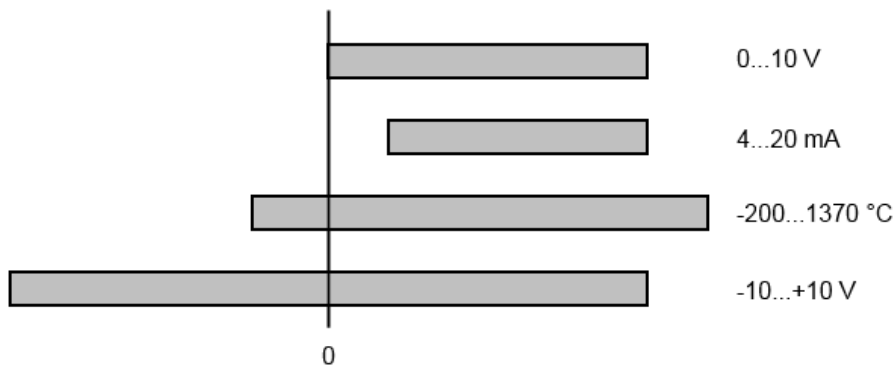

Fig. 24: Full scale value, measuring span

For the above **examples** this means:

- Measuring range 0...10 V: asymmetric unipolar, FSV = 10 V, measuring span = 10 V
- Measuring range 4...20 mA: asymmetric unipolar, FSV = 20 mA, measuring span = 16 mA
- Measuring range -200...1370 °C: asymmetric bipolar, FSV = 1370 °C, measuring span = 1570 °C
- Measuring range -10...+10 V: symmetric bipolar, FSV = 10 V, measuring span = 20 V

Depending on the functionality, an analog input channel may have a technical measuring range that exceeds the nominal measuring range, e.g. to gain more diagnostic information about the signal.

The case-by-case information in the device documentation on the behavior outside the nominal measuring range (measurement uncertainty, display value) must be observed.

The above thoughts are correspondingly applicable to analog output devices:

- The full scale value (FSV) becomes the output end value
- Here, too, there can be a (larger) technical output range in addition to the nominal output range

4.2.2 Measuring error/ measurement deviation

● Analog output



The following information also applies analogously to the output end value of analog output devices.

The relative measuring error as a specification value of a Beckhoff analog device is specified in % of the nominal FSV (output end value) and calculated as the quotient of the numerically largest probable deviation from the true measured value (output value) with respect to the FSV (output end value):

$$\text{Measuring error} = \frac{\left| \text{max. deviation} \right|}{\text{full scale value}}$$

It should be noted here that the "true measured value" cannot be determined with infinite accuracy either, but can only be determined via reference devices with a higher expenditure of technology and measuring time and thus a significantly lower measurement uncertainty.

The value therefore describes the result window in which the measured value determined by the device under consideration (Beckhoff analog device) lies with a very high probability in relation to the "true value". Thus, colloquially, this is a "typical" value (typ.); this expresses that the vast statistical majority of values will be within the specification window, but in rare cases there may/will be deviations outside the window.

For this reason, the term "measurement uncertainty" has become established for this window, since "error" is now used to refer to known disturbance effects that can generally be systematically eliminated.

The uncertainty of measurement must always be considered in relation to potential environmental influences:

- invariable electrical channel properties such as temperature sensitivity,
- variable settings of the channel (noise via filters, sampling rate, ...).

Measurement uncertainty specifications without further operational limitation (also called "service error limit") can be assumed as a value "over everything": entire permissible operating temperature range, default setting, etc.

The window is always to be understood as a positive/negative span with "±", even if occasionally indicated as a "half" window without "±".

The maximum deviation can also be specified directly.

Example: measuring range 0...10 V (FSV = 10 V) and measurement uncertainty $< \pm 0.3\%_{\text{FSV}} \rightarrow$ the expected maximum usual deviation is ± 30 mV in the permissible operating temperature range.

● Lower measurement uncertainty possible



If this specification also includes the temperature drift, a significantly lower measuring error can usually be assumed in case of a constant ambient temperature of the device and thermal stabilization after a user calibration.

4.2.3 Temperature coefficient tK [ppm/K]

An electronic circuit is usually temperature dependent to a greater or lesser degree. In analog measurement technology this means that when a measured value is determined by means of an electronic circuit, its deviation from the "true" value is reproducibly dependent on the ambient/operating temperature.

A manufacturer can alleviate this by using components of a higher quality or by software means.

The temperature coefficient, when indicated, specified by Beckhoff allows the user to calculate the expected measuring error outside the basic accuracy. The basic accuracy is usually specified for 23 °C ambient temperature, in special cases also at other temperature.

Due to the extensive uncertainty considerations that are incorporated in the determination of the basic accuracy, Beckhoff recommends a quadratic summation.

Example: Let the basic accuracy be $\pm 0.01\%$ typ. (full scale value), $tK = 20$ ppm/K typ at 23 °C.; the accuracy A35 at 35 °C is wanted, hence $\Delta T = 12$ K:

$$G35 = \sqrt{(0.01\%)^2 + (12K \cdot 20 \frac{\text{ppm}}{K})^2} = 0.026\% \text{ full scale value, typ.}$$

Remarks: ppm $\triangleq 10^{-6}$ % $\triangleq 10^{-2}$

4.2.4 Single-ended/differential typification

For analog inputs Beckhoff makes a basic distinction between two types: *single-ended* (SE) and *differential* (DIFF), referring to the difference in electrical connection with regard to the potential difference.

The diagram shows two-channel versions of an SE module and a DIFF module as examples for all multi-channel versions.

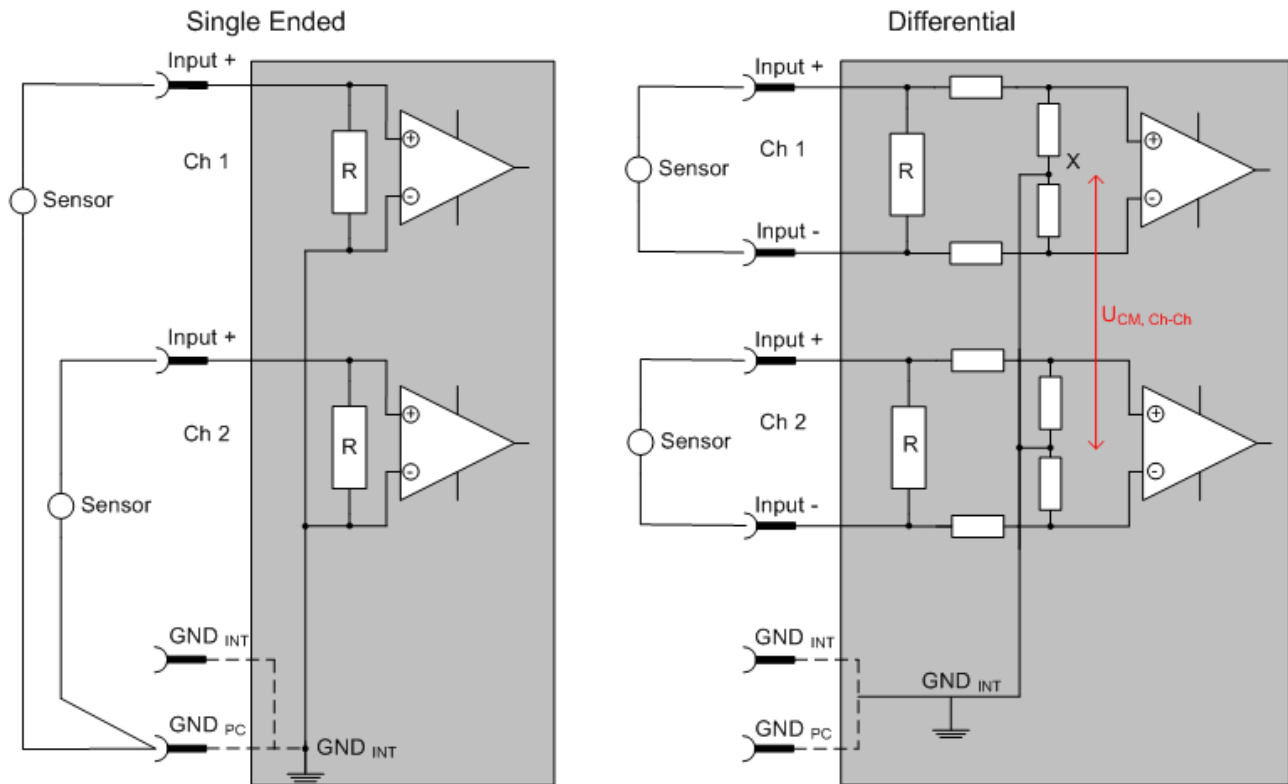

Fig. 25: SE and DIFF module as 2-channel version

Note: Dashed lines indicate that the respective connection may not necessarily be present in each SE or DIFF module. Electrical isolated channels are operating as differential type in general, hence there is no direct relation (voltaic) to ground within the module established at all. Indeed, specified information to recommended and maximum voltage levels have to be taken into account.

The basic rule

- Analog measurements always take the form of voltage measurements between two potential points. For voltage measurements a large R is used, in order to ensure a high impedance. For current measurements a small R is used as shunt. If the purpose is resistance measurement, corresponding considerations are applied.
 - Beckhoff generally refers to these two points as input+/signal potential and input-/reference potential.
 - For measurements between two potential points two potentials have to be supplied.
 - Regarding the terms “single-wire connection” or “three-wire connection”, please note the following for pure analog measurements: three- or four-wire connections can be used for sensor supply, but are not involved in the actual analog measurement, which always takes place between two potentials/wires. In particular this also applies to SE, even though the term suggests that only one wire is required.
- The term “electrical isolation” should be clarified in advance. Beckhoff I/O devices feature 1 to 8 or more analog channels; with regard to the channel connection a distinction is made in terms of:
 - how the channels WITHIN a module relate to each other, or
 - how the channels of SEVERAL modules relate to each other.

The property of electrical isolation indicates whether the channels are directly connected to each other.

- Beckhoff I/O devices always feature electrical isolation between the field/analog side and the bus/EtherCAT side. In other words, if two analog I/O devices are not connected via the power contacts (cable), they are effectively electrically isolated.
- If channels within a device are electrically isolated, or if a single-channel device has no power contacts, the channels are effectively always differential. See also explanatory notes below. Differential channels are not necessarily electrically isolated.
- Analog measuring channels are subject to technical limits, both in terms of the recommended operating range (continuous operation) and the destruction limit. Please refer to the respective device documentation for further details.

Explanation

• Differential (DIFF)

- Differential measurement is the most flexible concept. The user can freely choose both connection points, input+/signal potential and input-/reference potential, within the framework of the technical specification.
- A differential channel can also be operated as SE, if the reference potential of several sensors is linked. This interconnection may take place via the system GND.
- Since a differential channel is configured symmetrically internally (cf. Fig. SE and DIFF module as 2-channel variant), there will be a mid-potential (X) between the two supplied potentials that is the same as the internal ground/reference ground for this channel. If several DIFF channels are used in a module without electrical isolation, the technical property V_{CM} (common-mode voltage) indicates the degree to which the mean voltage of the channels may differ.
- The internal reference ground may be accessible as connection point at the device, in order to stabilize a defined GND potential in the device. In this case it is particularly important to pay attention to the quality of this potential (noiselessness, voltage stability). At this GND point a wire may be connected to make sure that $V_{CM,max}$ is not exceeded in the differential sensor cable. If differential channels are not electrically isolated, usually only one $V_{CM,max}$ is permitted. If the channels are electrically isolated this limit should not apply, and the channels voltages may differ up to the specified separation limit.
- Differential measurement in combination with correct sensor wiring has the special advantage that any interference affecting the sensor cable (ideally the feed and return line are arranged side by side, so that interference signals have the same effect on both wires) has very little effect on the measurement, since the potential of both lines varies jointly (hence the term common mode). In simple terms: Common-mode interference has the same effect on both wires in terms of amplitude and phasing.
- Nevertheless, the suppression of common-mode interference within a channel or between channels is subject to technical limits, which are specified in the technical data.
- Further helpfully information on this topic can be found on the documentation page *Configuration of 0/4..20 mA differential inputs* (see documentation for the EL30xx terminals, for example).

• Single-ended (SE)

- If the analog circuit is designed as SE, the input/reference wire is internally fixed to a certain potential that cannot be changed. This potential must be accessible from outside of the device on at least one point for connecting the reference potential, e.g. via the power contacts (cable).
- In other words, in situations with several channels SE offers users the option to avoid returning at least one of the two sensor cables to the device (in contrast to DIFF). Instead, the reference wire can be consolidated at the sensors, e.g. in the system GND.
- A disadvantage of this approach is that the separate feed and return line can result in voltage/current variations, which a SE channel may no longer be able to handle. See common-mode interference. A V_{CM} effect cannot occur, since the device channels are internally always 'hard-wired' through the input/reference potential.

Typification of the 2/3/4-wire connection of current sensors

Current transducers/sensors/field devices (referred to in the following simply as 'sensor') with the industrial 0/4-20 mA interface typically have internal transformation electronics for the physical measured variable (temperature, current, etc.) at the current control output. These internal electronics must be supplied with energy (voltage, current). The type of cable for this supply thus separates the sensors into *self-supplied* or *externally supplied* sensors:

Self-supplied sensors

- The sensor draws the energy for its own operation via the sensor/signal cable + and -. So that enough energy is always available for the sensor's own operation and open-circuit detection is possible, a lower limit of 4 mA has been specified for the 4-20 mA interface, i.e., the sensor allows a minimum current of 4 mA and a maximum current of 20 mA to pass.
- 2-wire connection see Fig. 2-wire connection, cf. IEC60381-1
- Such current transducers generally represent a current sink and thus like to sit between + and – as a 'variable load'. See also the data of the sensor manufacturer.

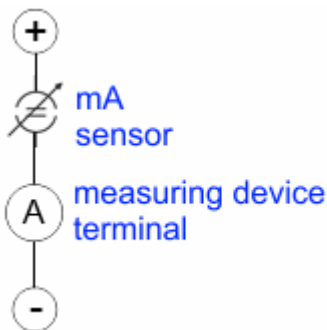

Fig. 26: 2-wire connection

Therefore, they are to be connected according to the Beckhoff terminology as follows:

preferably to '**single-ended**' inputs if the +Supply connections of the device are also to be used - connect to +Supply and Signal.

They can, however, also be connected to '**differential**' inputs, if the termination to GND is then manufactured on the application side – to be connected with the right polarity to +Signal and –Signal. It is important to refer to the information page *Configuration of 0/4...20 mA differential inputs* (see documentation for the EL30xx terminals, for example)!

Externally supplied sensors

No external supply for sensors / actuators

⚠ WARNING

An external supply of sensors / actuators connected to I/O devices of the ELX/EPX series is not permitted!

All I/O devices of the ELX/EPX series are energy-supplying, associated equipment in terms of intrinsic safety. Therefore, connected sensors or actuators are supplied exclusively via the respective channel of the I/O device and must not be externally supplied in any form (e.g. via an additional, external supply voltage).

This limitation is also independent of whether the additional, external supply is energy-limited in the sense of IEC 60079-11.

Connection of any externally powered, intrinsically safe circuits to an I/O device of the ELX/EPX series is contrary to the intended use and the specified technical data on explosion protection. The explosion protection provided by the specified ignition protection type is thus automatically extinguished.

4.2.5 Common-mode voltage and reference ground (based on differential inputs)

Common-mode voltage (V_{cm}) is defined as the average value of the voltages of the individual connections/inputs and is measured/specified against reference ground.

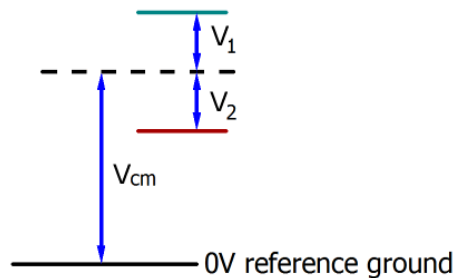

Fig. 27: Common-mode voltage (V_{cm})

The definition of the reference ground is important for the definition of the permitted common-mode voltage range and for measurement of the common-mode rejection ratio (CMRR) for differential inputs.

The reference ground is also the potential against which the input resistance and the input impedance for single-ended inputs or the common-mode resistance and the common-mode impedance for differential inputs is measured.

The reference ground is usually accessible at or near the I/O device. Locations for this can be terminal contacts, power contacts/power line or just a mounting rail.

Please refer to the documentation regarding positioning. The reference ground should be specified for the device under consideration.

For multi-channel I/O devices with resistive (= direct, ohmic, galvanic) or capacitive connection between the channels, the reference ground should preferably be the symmetry point of all channels, taking into account the connection resistances.

Reference ground samples for Beckhoff IO devices:

1. Internal AGND fed out: EL3102/EL3112, resistive connection between the channels
2. 0 V power contact: EL3104/EL3114, resistive connection between the channels and AGND; AGND connected to 0 V power contact with low-resistance
3. Earth or SGND (shield GND):
 - EL3174-0002: Channels have no resistive connection between each other, although they are capacitively coupled to SGND via leakage capacitors
 - EL3314: No internal ground fed out to the terminal points, although capacitive coupling to SGND

4.2.6 Dielectric strength

A distinction should be made between:

- Dielectric strength (destruction limit): Exceedance can result in irreversible changes to the electronics
 - Against a specified reference ground
 - Differential
- Recommended operating voltage range: If the range is exceeded, it can no longer be assumed that the system operates as specified
 - Against a specified reference ground
 - Differential

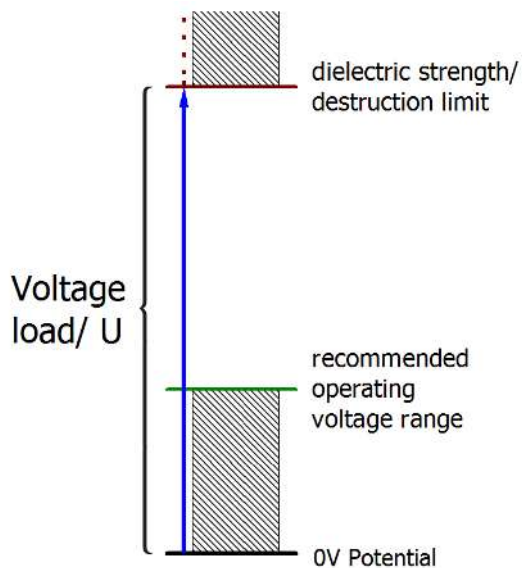

Fig. 28: Recommended operating voltage range

The device documentation may contain particular specifications and timings, taking into account:

- Self-heating
- Rated voltage
- Insulating strength
- Edge steepness of the applied voltage or holding periods
- Normative environment (e.g. PELV)

4.2.7 Temporal aspects of analog/digital conversion

● Analog output



The following information applies analogously to analog signal output via DAC (digital-to-analog converter).

The conversion of the constant electrical input signal to a value-discrete digital and machine-readable form takes place in the analog Beckhoff EL/KL/EP input modules with ADC (analog digital converter). Although different ADC technologies are common, from the user's point of view they all have one common feature: after the end of the conversion, a certain digital value is available for further processing in the controller. This digital value, the so-called analog process data, has a fixed temporal relationship with the "original parameter", i.e. the electrical input value. Therefore, corresponding temporal characteristic data can be determined and specified for Beckhoff analogue input devices.

This process involves several functional components, which act more or less strongly in every AI (analog input) module:

- the electrical input circuit
- the analog/digital conversion
- the digital further processing
- the final provision of the process and diagnostic data for collection at the fieldbus (EtherCAT, K-bus, etc.)

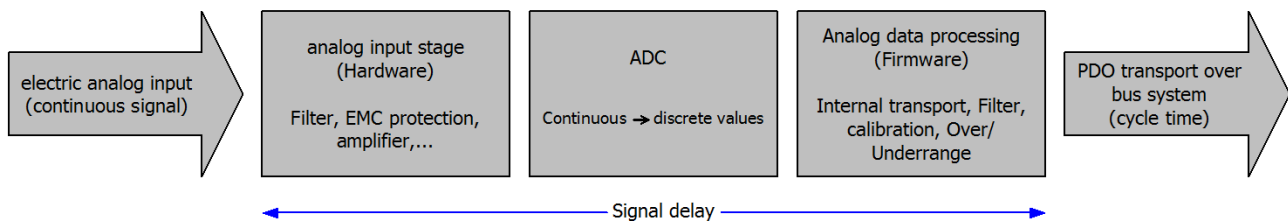

Fig. 29: Signal processing analog input

Two aspects are crucial from a user perspective:

- “How often do I receive new values?”, i.e. a sampling rate in terms of speed with regard to the device/channel
- What delay does the (whole) AD conversion of the device/channel cause?
So hardware and firmware parts in toto. For technological reasons, the signal characteristics must be considered to determine this specification: depending on the signal frequency, there may be different propagation times through the system.

This is the “external” view of the “Beckhoff AI channel” system – internally the signal delay in particular is composed of different components: hardware, amplifier, conversion itself, data transport and processing. Internally a higher sampling rate may be used (e.g. in the deltaSigma converters) than is offered “externally” from the user perspective. From a user perspective of the “Beckhoff AI channel” component this is usually irrelevant or is specified accordingly, if it is relevant for the function.

For Beckhoff AI devices the following specification parameters for the AI channel are available for the user from a temporal perspective:

1. Minimum conversion time [ms, μ s]

This is the reciprocal value of the maximum **sampling rate** [Sps, samples per second]:

Specifies how often the analog channel provides a newly detected process data value for collection by the fieldbus. Whether the fieldbus (EtherCAT, K-bus) fetches the value with the same speed (i.e. synchronous), or more quickly (if the AI channel operates in slow FreeRun mode) or more slowly (e.g. with oversampling), is then a question of the fieldbus setting and which modes the AI device supports.

For EtherCAT devices the so-called toggle bit indicates (by toggling) for the diagnostic PDOs when a newly determined analog value is available.

Accordingly, a maximum conversion time, i.e. a smallest sampling rate supported by the AI device, can be specified.

Corresponds to IEC 61131-2 Chap. 7.10.2 2, "Sampling repeat time"

2. Typical signal delay

Corresponds to IEC 61131-2, Chapter 7.10.2 1, "Sampling duration". From this perspective it includes all internal hardware and firmware components, but not "external" delay components from the fieldbus or the controller (TwinCAT).

This delay is particularly relevant for absolute time considerations, if AI channels also provide a timestamp that corresponds to the amplitude value – which can be assumed to match the physically prevailing amplitude value at the time.

Due to the frequency-dependent runtime of a signal, a dedicated value can only be specified for a given signal. The value also depends on possibly changing filter settings of the channel.

A typical characterization in the device documentation can be:

2.1 Signal delay (step response)

Keyword settling time:

The square wave signal can be generated externally with a frequency generator (note impedancel!).

The 90% limit is used as detection threshold.

The signal delay [ms, μ s] is then the time interval between the (ideal) electrical square wave signal and the time when the analog process value has reached the 90% amplitude.

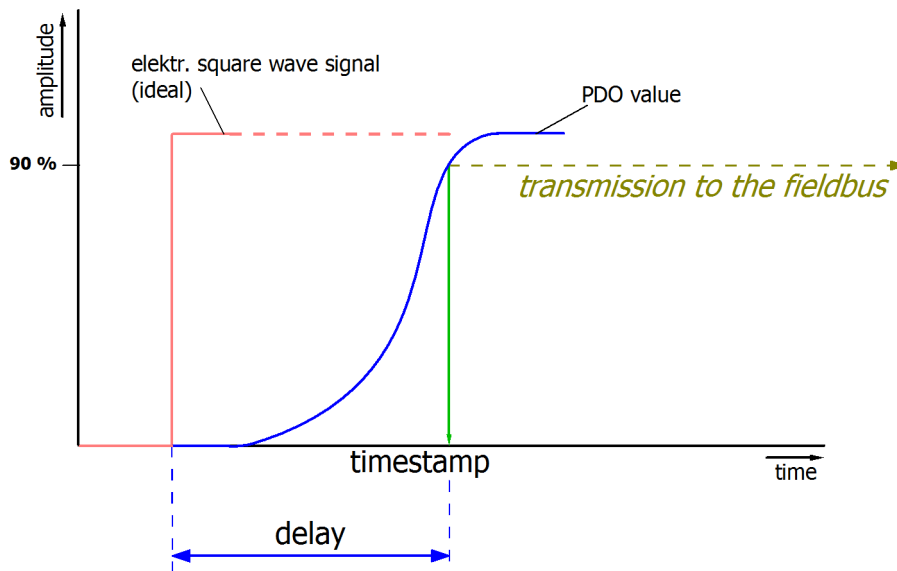

Fig. 30: Diagram Signal delay (step response)

2.2 Signal delay (linear)

Keyword group delay:

Describes the delay of a frequency-constant signal

Test signal can be generated externally with a frequency generator, e.g. as sawtooth or sine. Reference would then be a simultaneous square wave signal.

The signal delay [ms, µs] is then the time interval between the applied electrical signal of a certain amplitude and the moment when the analog process value reaches the same value.

For this purpose, the test frequency must be selected in a reasonable range; this can be, for example, 1/20 of the maximum sampling rate.

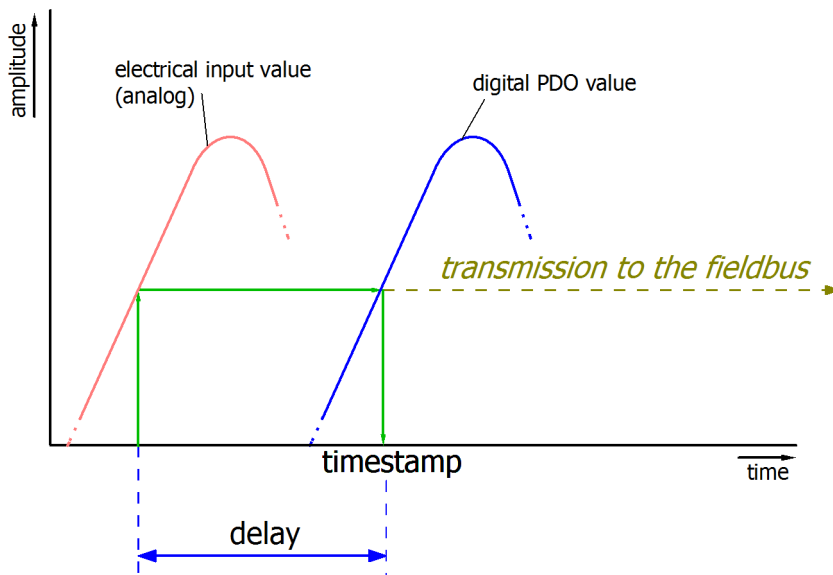

Fig. 31: Diagram Signal delay (linear)

3. Additional information

Additional information may be provided in the specification, e.g.

- actual sampling rate of the ADC (if different from the channel sampling rate)
- time correction values for runtimes with different filter settings
- etc.

4.3 Basic principles of strain gauge technology

There are the following listed identities of names of used voltage types within this remaining documentation:

Name	Used	
	in the following section	corresponds in this remaining documentation
Supply-/ Excitation voltage	U_{Exc}	U_V
Bridge-Difference voltage	U_{Bridge}	U_{IN} , U_{diff} or U_D
Compensation-/ Reference voltage	U_{Sense}	U_{ref} or U_{Ref}

Names of the used voltage types

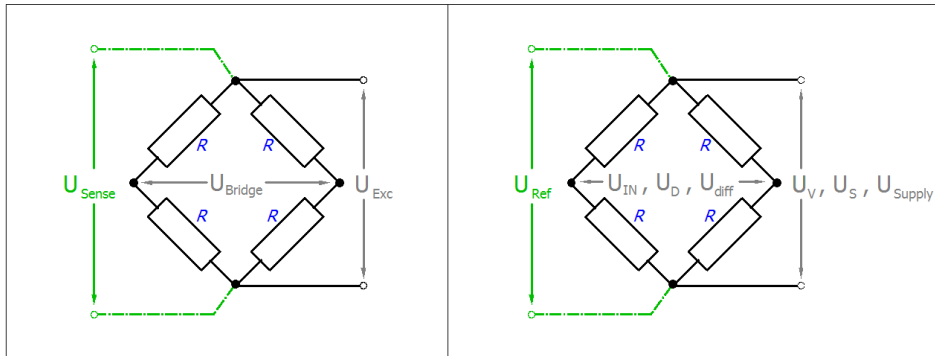

Fig. 32: Used names: in the following section (left), in this remaining documentation (right)

Basic information on the technological field of strain gauges (SG)/ load cells as metrological instruments is to be given below. The information is of general nature; it is up to the user to check the extent to which it applies to his application.

- Strain gauges serve either to directly measure the static (0 to a few Hz) or dynamic (up to several kHz) elongations, compressions or torsions of a body by being directly fixed to it, or to measure various forces or movements as part of a sensor (e.g. load cells/force transducers, displacement sensor, vibration sensors). The evaluated quantity is the change of the strain gauge property (e.g. electrical resistance).
- In the case of the optical strain gauge (e.g. Bragg grating), an application of force causes a proportional change in the optical characteristics of a fiber used as a sensor. Light with a certain wavelength is fed into the sensor. Depending upon the deformation of the grating, which is laser-cut into the sensor, due to the mechanical load, part of the light is reflected and evaluated using a suitable measuring transducer (interrogator).

The commonest principle in the industrial environment is the electrical strain gauge. There are many common terms for this type of sensor: load cell, weighbridge, etc.

Structure of electrical strain gauges

A strain gauge consists of a carrier material (e.g. a stretchable plastic film) with an applied metal film from which a structure of deformable thin film electrical resistor is worked in very different geometrical forms, depending on the requirements.

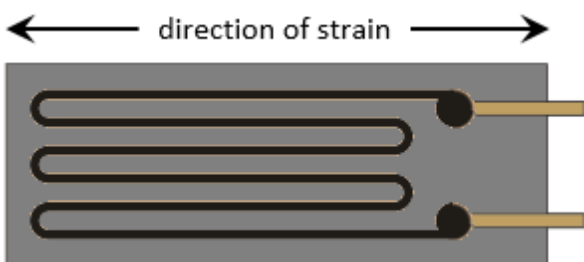

Fig. 33: Schematic view of a strain gauge

This utilizes a behavior whereby, for example in the case of strain, the length of a metallic resistance network increases and its diameter decreases, as a result of which its electrical resistance increases measurable:

$$\Delta R/R = k \cdot \epsilon.$$

$\epsilon = \Delta l/l$ thereby corresponds to the relative elongation; the strain sensitivity is called the k-factor. This also gives rise to the typical track layout of the conductive material within the strain gauge: the resistor track or course is laid in a meandering pattern in order to expose the longest possible length to the strain and to increase the selectivity of the force direction effect simultaneously.

Example:

The elongation $\epsilon = 0.1 \%$ of a strain gauge with k-factor 2 causes an increase in the resistance of 0.2 %. Typical resistive materials are constantan ($k \approx 2$) or platinum tungsten (92PT, 8W with $k \approx 4$). In the case of semiconductor strain gauges a silicon structure is glued to a carrier material. The conductivity is changed primarily by deformation of the crystal lattice (piezo-resistive effect); k-factors of up to 200 can be achieved.

Measurement of signals

The change in resistance of an individual strain gauge can be determined in principle by resistance measurement (current/voltage measurement) using a 2/3/4-wire measurement technique.

Usually 1/2/4 strain gauges are arranged in a Wheatstone bridge (-> quarter/half/full bridge); the nominal resistance/impedance R_0 of all strain gauges (and the auxiliary resistors used if necessary) is usually equivalent to $R1 = R2 = R3 = R4 = R_0$. Typical values in the non-loaded state so are $R_0 = 120 \Omega, 350 \Omega, 700 \Omega$ or $1 \text{ k}\Omega$.

The full bridge possesses the best characteristics such as increased linearity in the feeding of current/voltage, up to four times the sensitivity of the quarter-bridge as well as systematic compensation of disturbing influences such as temperature drift and creeping. In order to achieve high sensitivity, the four individual strain gauges are arranged on the object to be measured (the carrier) in such a way, that two are elongated and two are compressed in each case.

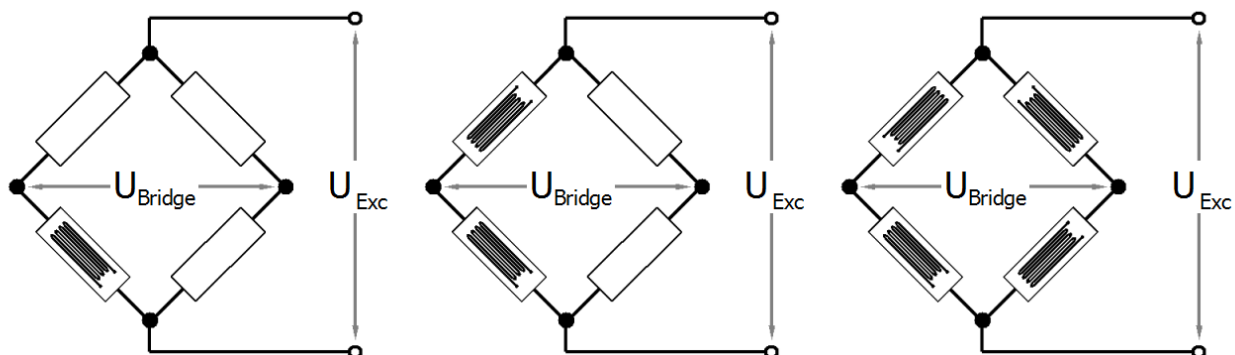

Fig. 34: quarter, half, and full bridge

At this point, the three most important voltages in the bridge environment are defined:

- U_{Exc} :
 - this is the feed voltage of the bridge as it comes from the measuring device or from an external source,
 - usually in the range 1...12 V DC,
 - it is fed to the bridge via supply line. Since current flows there, a voltage drop always occurs across the supply line; therefore, the bridge effectively only sees a voltage $< U_{Exc}$,
 - other terms: U_v, U_s , excitation, supply.
- U_{Sense} :
 - this is the bridge supply voltage as the measuring device “sees” it,
 - usually in the range 1...12 V DC,
 - without an extra sense supply line (e.g. 6-wire operation of the full bridge) it is equal to U_{Exc} in the measuring device,

- if the bridge is operated **with** a sense line (full bridge: 6-wire operation, half bridge: 5-wire operation, quarter-bridge: 3/4-wire operation), U_{Sense} returns to the measuring device from the bridge virtually current-free and the measuring device knows the "true" U_{Exc} of the bridge,
- other terms: U_{Ref} , reference, RemoteSense, feedback, compensation.
- U_{Bridge} :
 - this is the very small differential bridge voltage "generated" by the load in the bridge, which is to be measured by the measuring device,
 - it returns to the measuring device from the bridge virtually current-free and is mostly in the range 1..50 mV, depending on the magnitude of U_{Exc} , the load and the bridge sensitivity,
 - other terms: U_{D} , $U_{\text{Differential}}$, signal, AI.

The measuring bridges can be operated with constant current, constant voltage, or also with AC voltage using the carrier frequency method.



Measuring procedure

The Beckhoff EL/KL335x and ELM35/37xx terminals only support excitation with constant voltage. If excitation with AC is required, please contact Beckhoff sales.

Full bridge strain gauge at constant voltage (ratiometric measurement)

Since the relative resistance change $\Delta R/R$ is low in relation to the nominal resistance R_0 , a simplified equation is given for the strain gauge in the Wheatstone bridge arrangement:

$$U_{\text{D}} / U_{\text{V}} = \frac{1}{4} \cdot (\Delta R1 - \Delta R2 + \Delta R3 - \Delta R4) / R_0 .$$

$\Delta R/R$ usually has a positive sign in the case of elongation and a minus sign in the case of compression.

A suitable measuring instrument measures the bridge supply voltage U_{Exc} (or U_{V}) and the resulting bridge voltage U_{Bridge} (or U_{D}), and forms the quotients from both voltages, i.e. the ratio. After further calculation and scaling the measured value is output, e.g. in form of the effective mass in kg. Due to the division of U_{Bridge} and U_{Exc} the measurement is in principle independent of changes in the supply voltage.

If the voltages U_{Bridge} and U_{Exc} are measured simultaneously, i.e. at the same moment, and placed in relation to each other, this is referred to as a ratiometric measurement.

The advantage of this is that (with simultaneous measurement!) brief changes in the supply voltage (e.g. EMC effects) or a generally inaccurate or temporal unstable supply voltage likewise have no effect on the measurement.

A change in U_{V} by e.g. 1 % creates the same percentage change in U_{D} according to the above equation. Due to the simultaneous measurement of U_{D} and U_{V} the error cancels itself out completely during the division.

4-wire vs. 6-wire connection

With a constant voltage supply, the magnitude of the current can be quite considerable, e.g. $12 \text{ V} / 350 \text{ } \Omega \approx 34.3 \text{ mA}$. This leads not only to dissipated heat, wherein the specification of the strain gauge employed must not be exceeded, but possibly also to measuring errors in the case of inadequate wiring due to line losses not being taken into account or compensated.

In principle a full bridge can be operated with a 4-conductor connection (two conductors for the supply U_{Exc} and two for the measurement of the bridge voltage U_{Bridge}).

If, for example, a 25 m copper cable (feed + return = 50 m) with a cross section q of 0.25 mm^2 is used from the sensor up to the evaluating measurement module, this results in a line resistance of

$$R_{\text{L}} = l / (\kappa \cdot q) = 50 \text{ m} / (58 \text{ S} \cdot \text{m/mm}^2 \cdot 0.25 \text{ mm}^2) = 3.5 \text{ } \Omega$$

If this value remains constant, then the error resulting from it can be calibrated out. However, assuming a realistic temperature change of, for example, 30° the line resistance R_{L} changes by

$$\Delta R_{\text{L}} = 30 \text{ K} \cdot 3.9 \cdot 10^{-3} \text{ 1/K} \cdot 3.5 \text{ } \Omega = 0.41 \text{ } \Omega.$$

In relation to a measuring bridge with $350 \text{ } \Omega$ input impedance this means a measuring error of $> 0.1 \text{ } \%$.

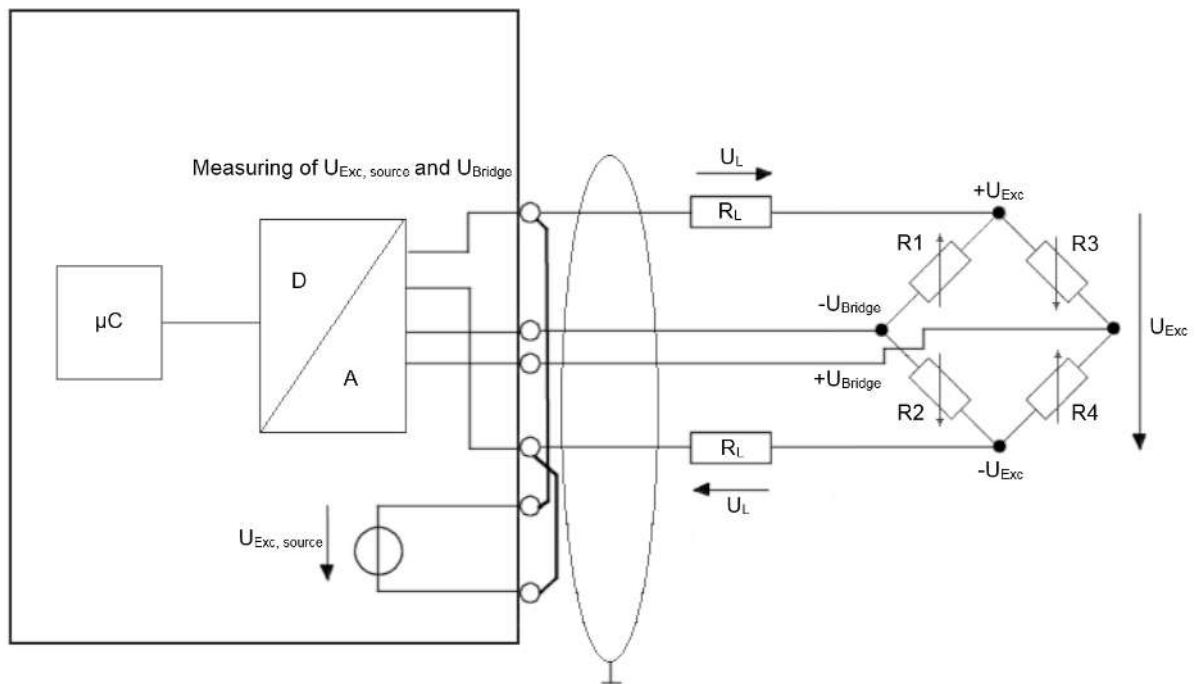

Fig. 35: 4-wire connection

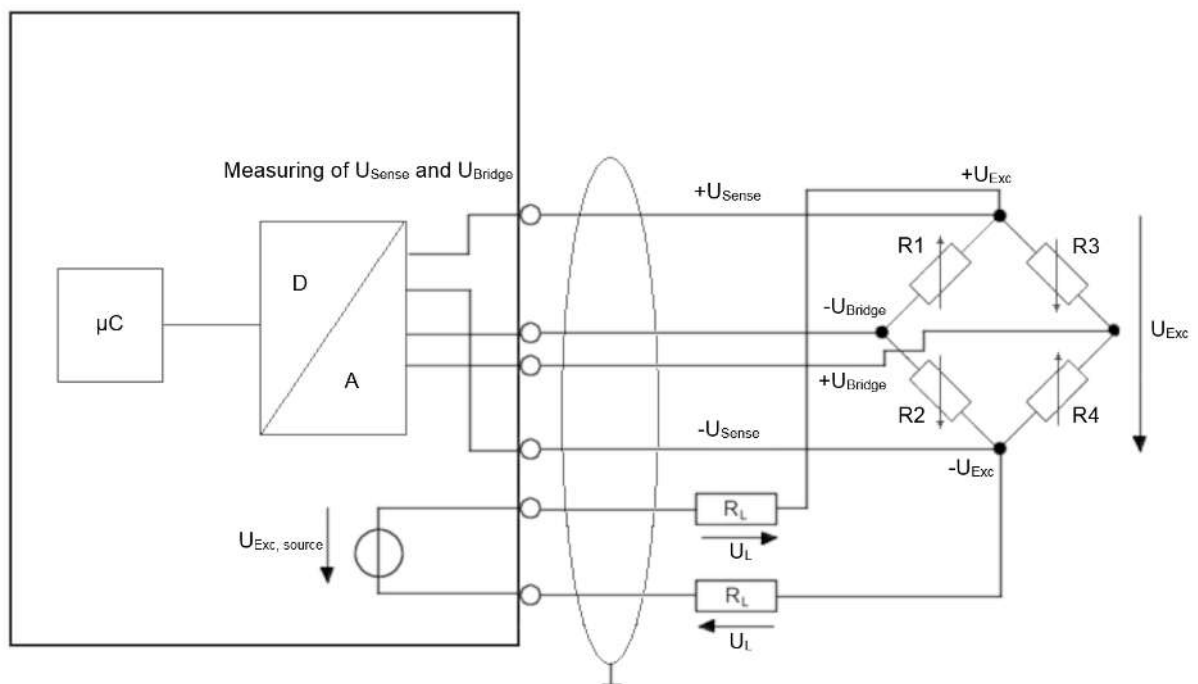

Fig. 36: 6-wire connection

This can be remedied by a 6-wire connection, in particular for precision applications.

The supply voltage U_{Exc} is thereby fed to the bridge (results in the pair of the current-carrying conductors, the feed line). The supply voltage U_{Exc} is only measured with high impedance as reference voltage U_{Sense} as the bridge voltage U_{Bridge} with two almost currentless return conductors each directly at the measuring bridge in the same way (often described as "Sense" input on measurement devices). Some measuring amplifiers then automatically increase the supply voltage thus far that the desired supply voltage is available at the bridge despite the potential difference on the supply line. In any case, the conductor-related errors can be compensated by the back measurement of U_{Sense} .

Since these are very small voltage levels of the order of mV and μV , all conductors should be screened.

Structure of a load cell with a strain gauge

One application of the strain gauge is the construction of load cells.

This involves gluing strain gauges (full bridges as a rule) to an elastic mechanical carrier, e.g. a double-bending beam spring element, and additionally covered to protect against environmental influences.

The individual strain gauges are aligned for maximum output signals according to the load direction (two strain gauges in the elongation direction and two in the compression direction).



Fig. 37: Example of a load cell

The most important characteristic data of a load cell



Characteristic data

Please enquire to the sensor manufacturer regarding the exact characteristic data!

Nominal load E_{\max}

Maximum permissible load for normal operation, e.g. 10 kg

Nominal characteristic value mV/V

The nominal characteristic describes the sensitivity of the load cell at nominal load E_{\max} . This unit less value indicates the unbalance of the Wheatstone bridge, which, at supply voltage U_{Exc} , results in the output voltage U_{Bridge} .

An example: a nominal characteristic value 2 mV/V means that, with a supply of $U_{\text{Exc}} = 10 \text{ V}$ and at the full load E_{\max} of the load cell, the maximum output voltage is

$U_{\text{Bridge}} = 10 \text{ V} \cdot 2 \text{ mV/V} = 20 \text{ mV}$. The nominal characteristic value is always a nominal value – a manufacturer's test report is included with good load cells stating the characteristic value determined for the individual load cell, e.g. 2.0782 mV/V.

Accuracy class of a scale according to OIML R60

The accuracy class is indicated by a letter (A, B, C, D) and an additional digit, which encodes the **scale interval d with a maximum number n_{max}** (1000), e.g. C4 means class C with a maximum of 4000 scale intervals. A division step is to be understood as the smallest possible/permissible unit with which weights can be differentiated. Smaller weight differences than the division unit can therefore not be clearly distinguished with the scale. The higher the quality of a weighing unit in terms of the components used and internal compensation elements, the finer its resolution.

The classes specify a maximum and minimum limit for **scale intervals d**:

- A: 50,000 – unlimited
- B: 5000 – 100,000
- C: 500 – 10,000
- D: 500 – 1000,

The scale interval $n_{max} = 4000$ states that, with a load cell with a resolution of $E_{min} = 1$ g, a calibratable set of scales can be built that has a maximum measuring range of $4000 \cdot E_{min} = 4$ kg. Since E_{min} is thereby a minimum specification, an 8 kg set of scales could be built – if the application allows – with the same load cell, wherein the calibratable resolution would then fall to $8 \text{ kg}/4000 = 2$ g. From another point of view the scale interval n_{max} is a maximum specification; hence, the above load cell could be used to build a set of scales with a measuring range of 4 kg, but a resolution of only 2000 divisions = 2 g, if this is adequate for the respective application. Also the classes differ in certain error limits related to non-repeatability/creep/TC.

Accuracy class according to PTB

The European accuracy classes are defined in an almost identical way (source: PTB Braunschweig).

Class	Calibration value e	Minimum load E_{min}	Maximum load E_{max}	
			Minimum value	Maximum value
I Fine scales	$0.001 \text{ g} \leq e$	100 e	50000 e	-
II Precision scales	$0.001 \text{ g} \leq e \leq 0.05 \text{ g}$	20 e	100 e	100000 e
	$0.1 \text{ g} \leq e$	50 e	5000 e	100000 e
III Commercial scales	$0.1 \text{ g} \leq e \leq 2 \text{ g}$	20 e	100 e	10000 e
	$5 \text{ g} \leq e$	20 e	500 e	10000 e
IIII Coarse scales	$5 \text{ g} \leq e$	10 e	100 e	1000 e

It should be noted that a scale can usually only be used in a situation that is subject to calibration requirements with a considerably smaller scale interval than the data sheet indicates for an unregulated situation.

Minimum calibration value E_{min}

This indicates the smallest mass that can be measured without the maximum permissible error of the load cell being exceeded [RevT].

This value is represented either by the equation $E_{min} = E_{max} / n$ (where n is an integer, e.g. 10000), or in % of E_{max} (e.g. 0.01%).

This means that a load cell with $E_{max} = 10$ kg has a maximum resolution of

$$E_{min} = 10 \text{ kg} / 10000 = 1 \text{ g} \text{ or } E_{min} = 10 \text{ kg} \cdot 0.01\% = 1 \text{ g}.$$

Resolution of the scale / strain gauge vs resolution of the electronic recording

As described above, scales have a scale interval, i.e. a number of resolvable steps, e.g. 6000d. A 12 kg scale could therefore resolve to 2 g, which is 0.016 % or 166 ppm of the full-scale value.

On the other hand, there is the question of what electrical analog acquisition is necessary for such a scale, if it is to be utilized to the full. The answer is found in the following steps:

- The resolution of the analog value acquisition must in any case be equal to the scale graduation, or preferably greater. 6000d is approximately $2^{12.5}$, so the analog value acquisition (ADC) must have at least 13 bits_{unsigned}, 14 bits signed if the analog input measures in bipolar mode (which is usually the case).
- However, 6000d means that the scale can unambiguously distinguish 6000 steps. This requirement must also be met by the analog value acquisition (weighing terminal). The measurement uncertainty of the weighing terminal is to be taken as the upper reference value for technically clearly distinguishable levels. So in this case it must be $< 166 \text{ ppm}_{\text{full-scale value}}$ for the 6000d scale to also meet a 6000d electronics.
- Ideally, the differential voltage U_{bridge} generated by the scale, e.g. 20 mV, should fully utilize the measuring range of the analog value acquisition (100 %), i.e., up to the full-scale value (FSV)! Otherwise, this must be taken into account in the following calculation.
- It should be noted that the analog specification of the measurement uncertainty for Beckhoff analog products can vary depending on the terminal/box:
 - with measurement error/uncertainty over the operating temperature range of the device, e.g. $\pm 0.01\%_{\text{full-scale value}}$ at $T_{\text{ambient}} = 0 \dots 55 \text{ }^\circ\text{C}$,
 - or more precisely broken down in the extended analog characteristics: Basic accuracy @ $T_{\text{ambient}} = 23 \text{ }^\circ\text{C}$ and temperature coefficient of e.g. 10 ppm/K.
- If an even more precise consideration is required, the basic accuracy (measurement uncertainty at 23 °C) must be broken down further. The basic accuracy contains the four manufacturer-dependent elements: gain error, offset error, nonlinearity and repeatability.
 - The offset error can easily be eliminated by a zero compensation (tare).
 - Likewise, the gain error can be determined by adjustment with a calibration weight.
 - The unavoidable remaining parameters are nonlinearity and repeatability. If these are provided in the Beckhoff device specification, they therefore represent the lowest limit for the possible "division" of the analog value acquisition. If, for example, the *non-linearity over the whole measuring range*, $E_{\text{Lin}} = 50 \text{ ppm}$ and the *repeatability* (at 23°C), $E_{\text{Rep}} = 20 \text{ ppm}$, a scale with 14285d could be constructed from this (1/70 ppm).
 - Note: This assumes, of course, that the temperature influence is eliminated by air conditioning and the noise of the analog recording is eliminated by (digital) filtering.

Minimum application range or minimum measuring range in % of rated load

This is the minimum measuring range or the minimum measuring range interval, which a calibratable load cell or scale must cover.

Example:

Above load cell $E_{\text{max}} = 10 \text{ kg}$; minimum application range e.g. 40 % E_{max} .

The used measuring range of the load cell must be at least 4 kg. The minimum application range can lie in any range between E_{min} and E_{max} , e.g. between 2 kg and 6 kg if a tare mass of 2 kg already exists for structural reasons. A relationship between n_{max} and E_{min} is thereby likewise apparent: $4000 \cdot 1 \text{ g} = 4 \text{ kg}$.

There are other important characteristic values, which are for the most part self-explanatory and need not be discussed further here, such as nominal characteristic value tolerance, input/output resistance, recommended supply voltage, nominal temperature range etc.

Parallel connection of strain gauges

It is usual to distribute a load mechanically to several strain gauge load cells at the same time. Hence, for example, the 3-point bearing of a silo container on three load cells can be realized. Taking into account wind loads and loading dynamics, the total loading of the silo including the dead weight of the container can thus be measured. The mechanically parallel-connected load cells are usually also electrically connected in parallel and to one measuring transducer, e.g. the EL3356. To this end the following must be observed:

- It is highly recommended that the load cells used are adjusted in the nominal characteristic value with a low tolerance, i.e. that they all have an approximately equal nominal characteristic value of e.g. 2 mV/V $\pm 0.1\%$. If the load center and thus the load distribution among the load cells changes during successive weighings of the same weight, the final result remains the same. On the other hand, in the case of non-adjusted load cells with e.g. 2 mV/V $\pm 10\%$, a variable load distribution due to a change in the force application point or weight center point leads to correspondingly variable weighing results.
- The input impedance of the load cells (as a rule, a few 10 Ω higher than the initial or nominal weight) must be such that the current supply capability of the supply (can be integrated into the transducer electronics) is not overloaded and
- the nominal characteristic value [mV/V] remains unchanged in the calculation, the rated load of the load cells must be added accordingly.

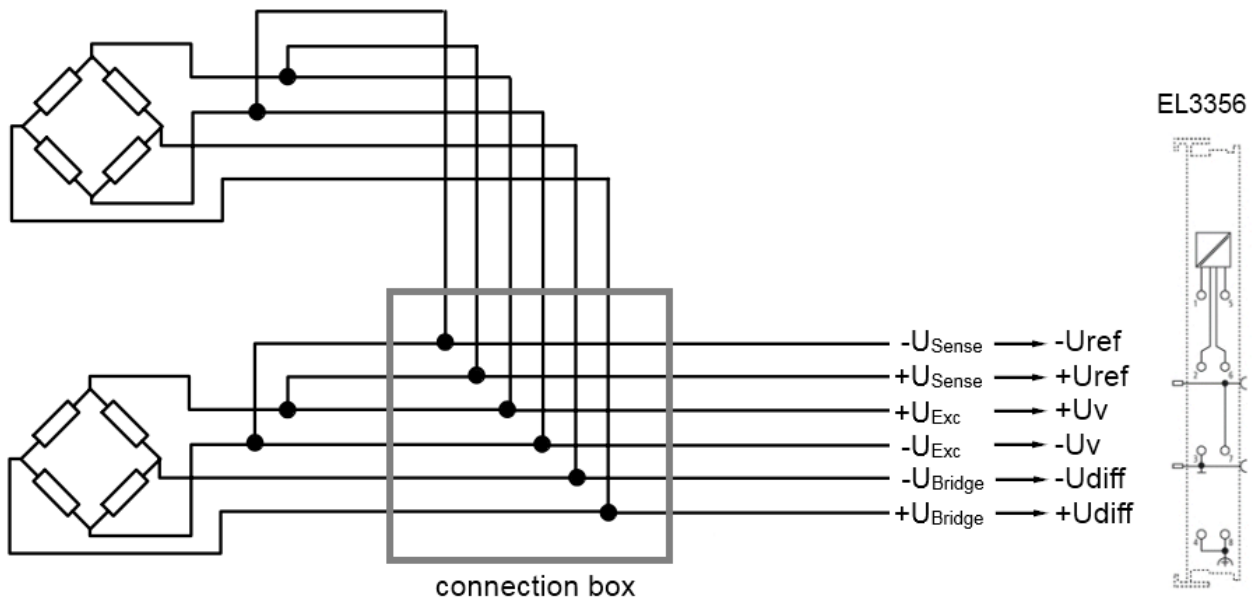

Fig. 38: Parallel strain gauge

Shunt calibration

Notes on shunt calibration

Note: Not all Beckhoff strain gauge/bridge measuring devices support shunt calibration.

Shunt calibration refers to a procedure in which a known resistor is temporarily connected parallel to a bridge resistor. This is possible with all bridge circuits (quarter/half/full bridge); example for full bridge:

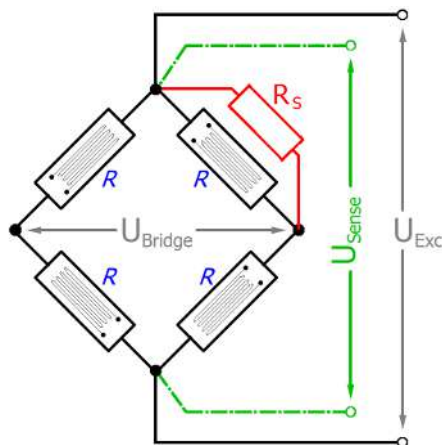

Fig. 39: Shunt calibration

This electrically simulates a load on the measuring bridge; depending on the situation, a measuring signal step change between 0.1 and a few mV/V occurs. The interesting thing is that the step change, which is dependent on all the elements involved, is predictable.

Shunt calibration is used, for example, to

- find wire breakages or wiring faults during commissioning,
- simplify the initial calibration of the measuring setup: if the sensor cannot be loaded, the gain of the electrical measurement can be checked through the known detuning. Data acquisition can be even more extensive if the shunt is installed upstream in the sensor or in the bridge, rather than in the measuring device (in this case the Beckhoff measuring terminal),
- detection of resistance changes (that change the gain) in cables, plugs, full/half/quarter bridge during operation,
- compensate for actual line resistances during commissioning without having to install an (expensive) compensating line. For this purpose, the determined detuning is compared with the theoretically expected detuning and a corresponding gain correction factor is calculated in the PLC or terminal (however, a technically better way with regard to line resistances would be to use compensating lines, i.e. 3-wire mode for quarter bridge, 5-wire mode for half bridge, 6-wire mode for full bridge).

Shunt calibration procedure

1. During commissioning, note the measured value at constant load, ideally without load.
2. Close the shunt and note the difference to the previous measured value. A signal step change in [mV/V] should occur which corresponds to the precalculated value.
3. During system operation the shunt calibration can be repeated regularly. The signal step change should not change significantly; if it does, it is an indication that electrically relevant components may have changed unintentionally.

Theoretically, the expected signal step change is based on the equation:

$$\frac{U_{IN}}{U_V} = \frac{R}{4 \cdot R_S}$$

is 0.875 mV/V for $R = 350 \Omega$ and $R_S = 100 \text{ k}\Omega$.

Formulas and information on shunt calibration can be found in high-quality technical literature (Keil, Hoffmann) and can in some cases be obtained from bridge manufacturers (Vishay, HBM). However, it should be noted that the actual bridge design in commercially available measuring bridges/strain gauges often goes beyond the fundamentals described in simple standard works with $R_1 \dots R_4 = R$. It is important to be aware of this, in order to be able to predict the signal step change [mV/V] during shunt calibration. Therefore, some aspects of actual measuring bridges are described below. Please note that the information is provided for general guidance only; for actual applications the user should discuss the finer details with the bridge manufacturer.

Input vs output impedance

Professionally manufactured measuring bridges/full bridges consist not only of the four bridge resistors R_1 , R_2 , R_3 , R_4 , but include a number of additional resistors and other sophisticated components, e.g. to compensate for temperature and non-linearity effects. The nominal or rated resistance of 120 or 350 Ω always refers to the output impedance (output resistance) of a bridge, i.e. the resistance that the measuring device sees at U_{Bridge} .

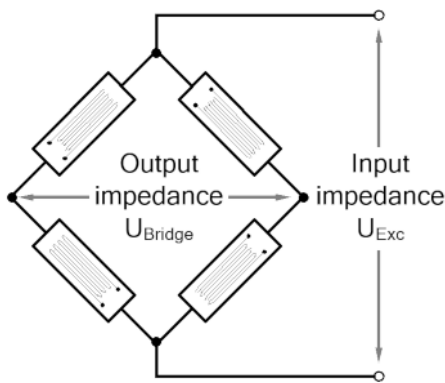

Fig. 40: Measuring bridge with 4 bridge resistors

Theoretically the input impedance (input resistance) is the same, although in practice it is up to 25% larger than the output impedance, since, for example, with 350 Ω bridges, 2x approx. 32 Ω are often installed (for background on this see e.g. Stefan Keil, "Beanspruchungsermittlung mit Dehnmessstreifen", 1995, Chap. 5.3), which are also detected by the sensor:

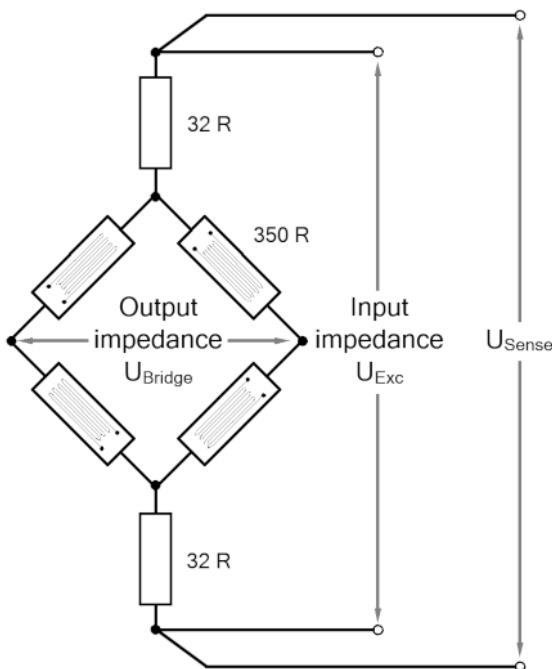

Fig. 41: Measuring bridge with 4 bridge resistors and 2 additional resistors

This is irrelevant in non-shunt mode, in which the load on the supply is actually reduced. However, in shunt mode this information is crucial if the signal step change is to be predicted correctly. In addition, bridge designs vary greatly across the world, depending on the manufacturer and price range; in some cases bridges are asymmetrical in terms of U_{Exc} .

Line resistances

The shunt bridges supply lines, which means the influence of their resistance must also be known or measured in order to be able to predict the signal step change. Formulas and information on resistances of cables, connectors and switches can be found in the specialist literature, manufacturer data sheets and internet sources. Values in the range of a few 10s to 100 mΩ are common for short lengths.

Step change prediction

Due to the different characteristics of bridges and environments, no comprehensive values or formulas for step change prediction in [mV/V] can be provided here. More meaningful is specific calculation according to the respective conditions, taking into account the components that are essential for the shunt calibration. Common simulation tools are available for this purpose; further information can be requested via measurement@beckhoff.com.

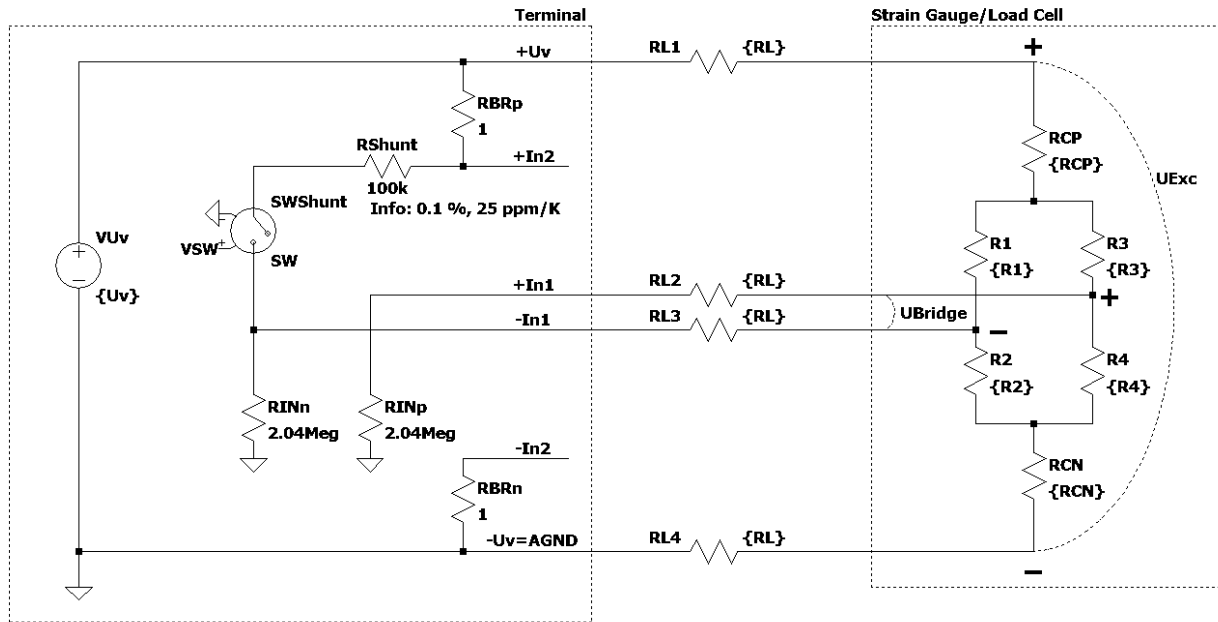

Fig. 42: Example 1 - Comprehensive consideration of the 4-wire connection for an ELM350x

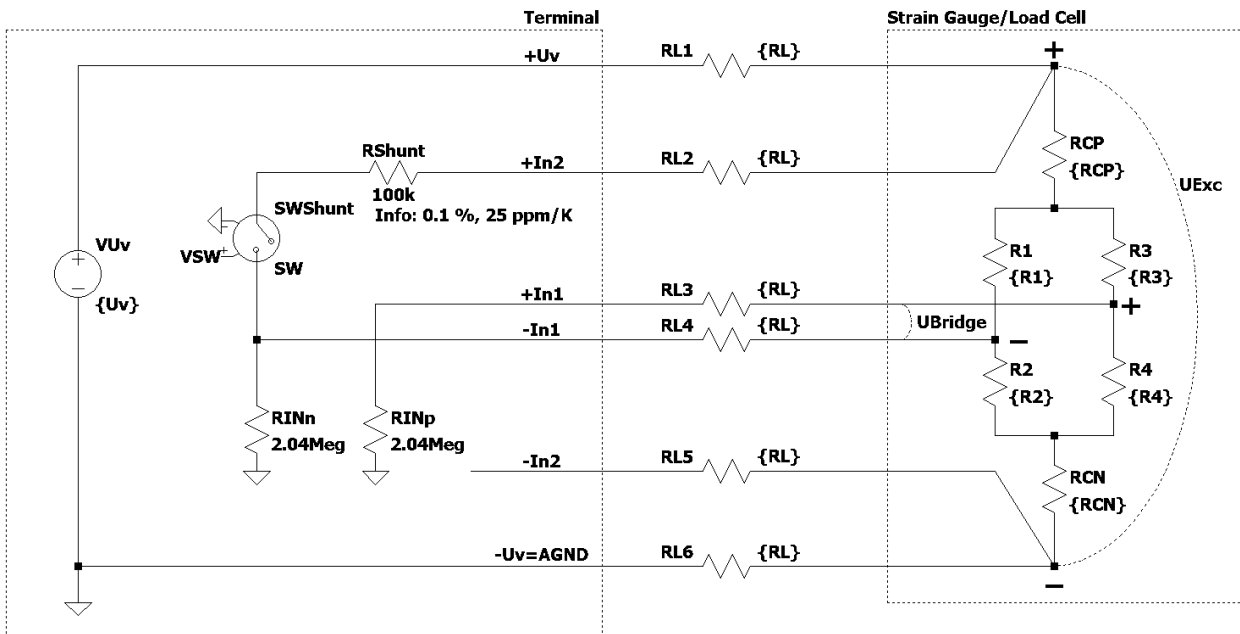

Fig. 43: Example 2 - Comprehensive consideration of the 6-wire connection for an ELM350x

Sources of error/disturbance variables

Inherent electrical noise of the load cell

Electrical conductors exhibit so-called thermal noise (thermal/Johnson noise), which is caused by irregular temperature-dependent movements of the electrons in the conductor material. The resolution of the bridge signal is already limited by this physical effect. The rms value e_n of the noise voltage can be calculated by:

$$e_n = \sqrt{4kTRB}$$

In the case of a load cell with $R_0 = 350 \Omega$ at an ambient temperature $T = 20 \text{ }^\circ\text{C}$ ($= 293\text{K}$) and a bandwidth of the measuring transducer of 50 Hz (and Boltzmann constant $k = 1.38 \cdot 10^{-23} \text{ J/K}$), the rms $e_n = 16.8 \text{ nV}$. The peak-peak noise e_{pp} is thus approx. $e_{pp} \approx 6.6 \cdot e_n = 111 \text{ nV}$ (thermal noise, 99.9 % interval of standard deviation).

Example:

For a bridge with 2 mV/V nominal characteristic value and supply of $U_{Exc} = 5 \text{ V}$, this results in an output voltage $U_{Bridge_max} = 5 \text{ V} \cdot 2 \text{ mV/V} = 10 \text{ mV}$ (for the nominal load) and therefore a maximum resolution of $10 \text{ mV} / 111 \text{ nV} = 90090$ digits. Converted into bit resolution: $\ln(90090)/\ln(2) \approx 16$ bits. Interpretation: a higher digital measuring resolution than 16 bits is thus inappropriate for such an analog signal in the first step. If a higher measuring resolution is used, then additional measures may need to be taken in the evaluation chain in order to gain a higher information content from the user- and noise superposition, e.g. hardware low-pass filter or software algorithms.

This resolution applies alone to the measuring bridge without any further interferences. The resolution of the measuring signal can be meaningfully increased by reducing the bandwidth of the measuring unit.

If the strain gauge is glued to a carrier (load cell) and wired up, both external electrical disturbances (e.g. thermovoltage at connection points) and mechanical vibrations in the vicinity (machines, drives, transformers and audible 50 Hz vibration due to magnetostriction etc.) can additionally impair the result of measurement.

Creep

Under a constant load, spring materials can further deform in the load direction. This process is reversible, but it generates a slowly changing measured value during the static measurement. In an ideal case the error can be compensated by constructive measures (geometry, adhesives).

Hysteresis

If even elongation and compression of the load cell take place, then the output voltage does not follow exactly the same curve, since the deformation of the strain gauge and the carrier runs different due to the adhesive and its layer thickness.

Temperature drift (inherent heating, ambient temperature)

Relatively large currents can flow in strain gauge applications. A full bridge with four 350 Ω resistors for example has a current consumption of $I = U_{Exc}/R_0 = 10 \text{ V} / 350 \Omega \approx 28.6 \text{ mA}$. The power dissipation of the whole full bridge is thus $P_{Exc} = U \cdot I = 10 \text{ V} \cdot 28.6 \text{ mA} = 286 \text{ mW}$. Depending on application (a cooling of the strain gauge takes place by heat dissipation into the carrier material) and carrier material a not insignificant error can arise that is termed apparent elongation. Therefore, the strain gauges on the sensor material are often counter-compensated by the manufacturer.

Inadequate circuit technology

As already shown, a full bridge may be able (due to the system) to fully compensate hysteresis, creep and temperature drift. Wiring-related measuring errors are avoided by the 6-conductor connection.

Measuring body and natural frequency

In the dynamic measurement of forces and weights, the setup and some of the properties of the transducer play an essential part in the attainable dynamics. The natural frequency of the complete system limits the dynamics of the application and is influenced by the spring constant of the measuring body and the coupled mass. The softer the measuring body ($=$ larger deformation under nominal load), the lower the natural frequency. In the case of measuring transducers with rigid measuring bodies, too, the coupled mass must always be included if the natural frequency is to be determined.

Load cells are technologically similar to force transducers, but have a softer structure and are usually manufactured at optimized cost. Consequently, the recommendation for the mechanical setup is:

- use a rigid measuring transducer and the lightest possible mounted parts,

- the natural frequency of the system should be at least 2-5 times higher than the measuring signal frequency (i.e. the dynamically moved test specimen from the application that is to be measured),
- Natural frequency specifications in data sheets apply only to the measuring transducer without mounted parts and are therefore not useable in the field. It is better to calculate with the nominal measuring path and masses of sensor plus mounted parts. The real natural frequency can be checked by means of a frequency analysis of the pulse response by FFT or manually by determining the period.

The natural frequency is to be calculated with:

$$f_0 = \frac{1}{2\pi} \cdot \sqrt{\frac{k}{m}} = \sqrt{\frac{F_{nom}}{4\pi^2 \cdot m \cdot s_{nom}}}$$

- f_0 = natural frequency of the complete setup [Hz]
- F_{nom} = nominal force or nominal load of the transducer [kg]
- s_{nom} = nominal measuring path of the transducer (deformation under nominal load) [m]
- m = sum of dead weight and coupled mass [kg]

With $F_{nom} = 50$ kg and $s_{nom} = 0.18$ mm, the resulting dependence on the mass, for example, is graphically:

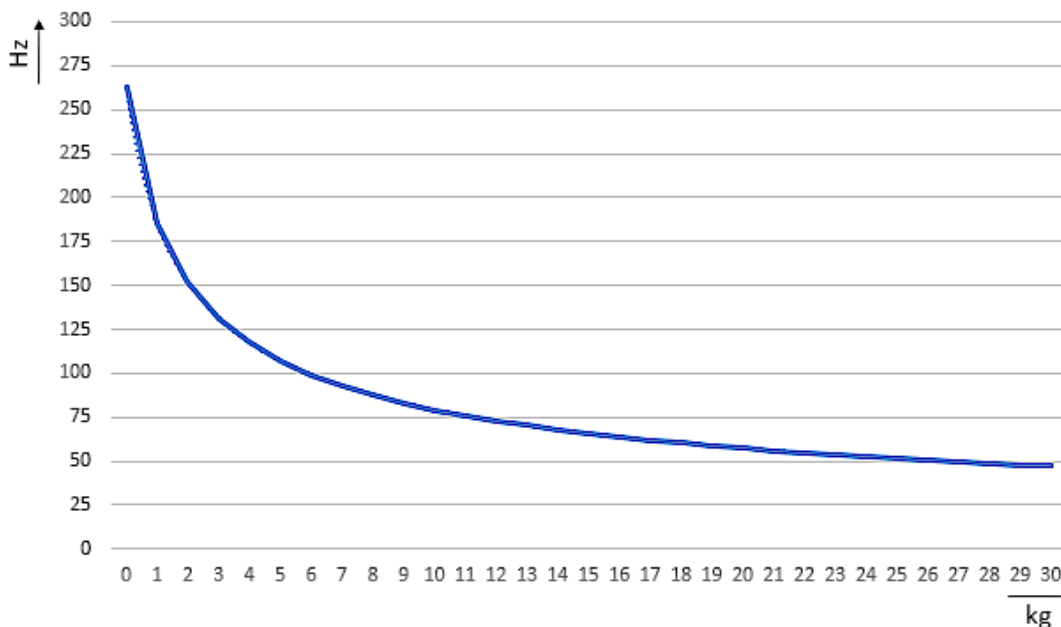

Fig. 44: Natural frequency as a function of mass

Recommendations for strain gauge measurement with Beckhoff modules

- Electrical connection:
 - Operation with an additional sense line for the bridge supply is recommended: Full bridge in 6-wire mode, half bridge in 5-wire mode, quarter bridge in 3/4-wire mode.
 - The use of full bridges instead of half or quarter bridges is generally recommended in order to achieve higher temperature stability and higher measuring accuracy.
- Selection of the feed voltage U_{Exc} :
 - A feed voltage of 5 V has proven to be useful in many cases.
 - In general it should be as high as possible within the permissible range according to the data sheet in order to achieve a large modulation of U_{Bridge} with the given nominal characteristic value [mV/V] and thus to maximize the electrical measuring range of the module (SNR increment).
 - However, it should be considered that the heating of the bridge in the load cell increases quadratically with U_{Exc} to a first approximation. With high feed voltages and insufficient heat dissipation from the sensor to the machine, this can lead to massive drift effects after switching on.

- If necessary, select a bridge with a higher nominal parameter [mV/V] or a higher internal resistance [Ω].
- Selection of the nominal load of the weighbridge:
 - It should be selected somewhat larger but as close as possible to the target load so that the mechanical and thus the electrical measuring range is utilized to the fullest extent possible.
 - The overload capacity of the load cell must be observed. Fast weighing procedures in particular can lead to excessive mechanical stresses; nevertheless, as stated above, the bridge should not be over-dimensioned (regarding E_{\max}).
 - The mechanical natural frequency of the load cell (in which the measuring bridge/strain gauge is installed!) or of the complete setup is to be considered in relation to the weighing procedures (number of product changes, product speed, product weights). If necessary, a significantly larger nominal load should be selected to the target load, because sensors with a higher nominal load have shorter nominal measuring paths and are thus mechanically more rigid. With a more rigid measuring body – usually the softest part of the entire setup – the natural frequency increases. As a result, the dynamics of the weighing procedure can be cleanly captured and measuring errors due to the natural oscillations of the weighing setup are avoided.
- Calibration/compensation of the bridge:
 - Regular zero compensation (tare) is recommended.
 - The tare effect should be observed in order to recognize a possibly damaged measuring bridge: the signal of a damaged measuring bridge drifts; it does not return to the original value after removal of the load.
 - For the compensation of a gain error, a compensation point close to the target load should be selected during commissioning and if possible during operation, especially if this lies well below the nominal load (measurements in the partial load range).
- Possible filtering of the measurement, dynamic effects:
 - In the case of fast sequential weighing procedures (several objects to be measured, e.g. products per second), it may be possible with adapted digital filters - despite an obviously “poor” measuring signal - to achieve a high measuring accuracy.
 - Overshoot effects can often be observed for example, the pickup device for measurement objects (products) actually always moves mechanically (even if only in the μm range).
 - The procedure of fast sequential weighing can also be dependent on the speed of which measurement objects (products) being moved over the weighting area; the filters for the measurement signal may then need to be dynamically adjusted.
 - The optimal signal analysis is supported by Beckhoff with various products: flexible filters in the EtherCAT modules, TwinCAT filter designer, TwinCAT filter library, TwinCAT Analytics and so on.

5 Parameterization and programming

5.1 Basics of the measurement functions

The measuring functions of the ELX3351 can be described as follows:

- The ELX3356 Analog Input Terminal is used to acquire the supply voltage to a load cell as a reference voltage, and the differential voltage that is proportional to the force acting on the cell.
- A full bridge must be connected. If only a quarter or half bridge is available, external auxiliary bridges should be added. In this case, the nominal characteristic value should be modified accordingly.
- The reference and differential voltages are measured simultaneously.
- Since the two voltages are measured at the same time, there is basically no need for a high-precision reference voltage with respect to the level.
The bridge supply and reference voltages are provided by the ELX3351 for the full bridge. A connection of other, externally supplied circuits (e.g. an external bridge supply) is not permitted!
- The change of the quotient of the differential and reference voltages corresponds to the relative force acting on the load cell.
- The quotient is converted into a weight and is output as process data.
- The data processing is subject to the following filtering procedures:
 - software filter IIR/FIR (if activated)
- The ELX3351 has an automatic compensation/self-calibration function.
 - Default state: self-calibration activated, execution every 3 minutes
 - Errors in the analog input stages (temperature drift, long-term drift etc.) are checked by regular automatic calibration, and compensated to bring the measurement within the permitted tolerance range.
 - The automatic function can be deactivated or activated in a controlled manner.

5.1.1 General notes

- The measuring ranges of both channels (supply voltage and bridge voltage) should always be used as widely as possible in order to achieve a high measuring accuracy.
We recommend a load cell that has such a sensitivity (e.g. 2 mV/V) that the largest possible bridge voltage (ideally ± 20 mV) is generated.
Note the input voltages (see [Technical data](#) [► 13]).

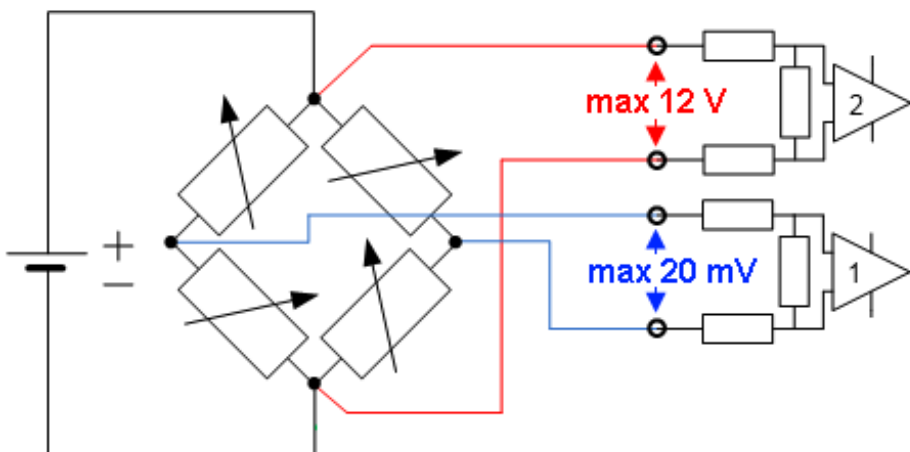

Fig. 45: Max. input voltages

- Parallel operation of load cells is possible with the ELX3351. Please note:
 - Load cells approved and calibrated by the load cell manufacturer for parallel operation should be used. The nominal characteristic values [mV/V], zero offset [mV/V] and impedance [Ω , ohm] are then usually adjusted accordingly.

- A 6-wire connection is expressly recommended.
- All the relevant operating parameters (e.g. the minimum bridge input resistance) must be observed.

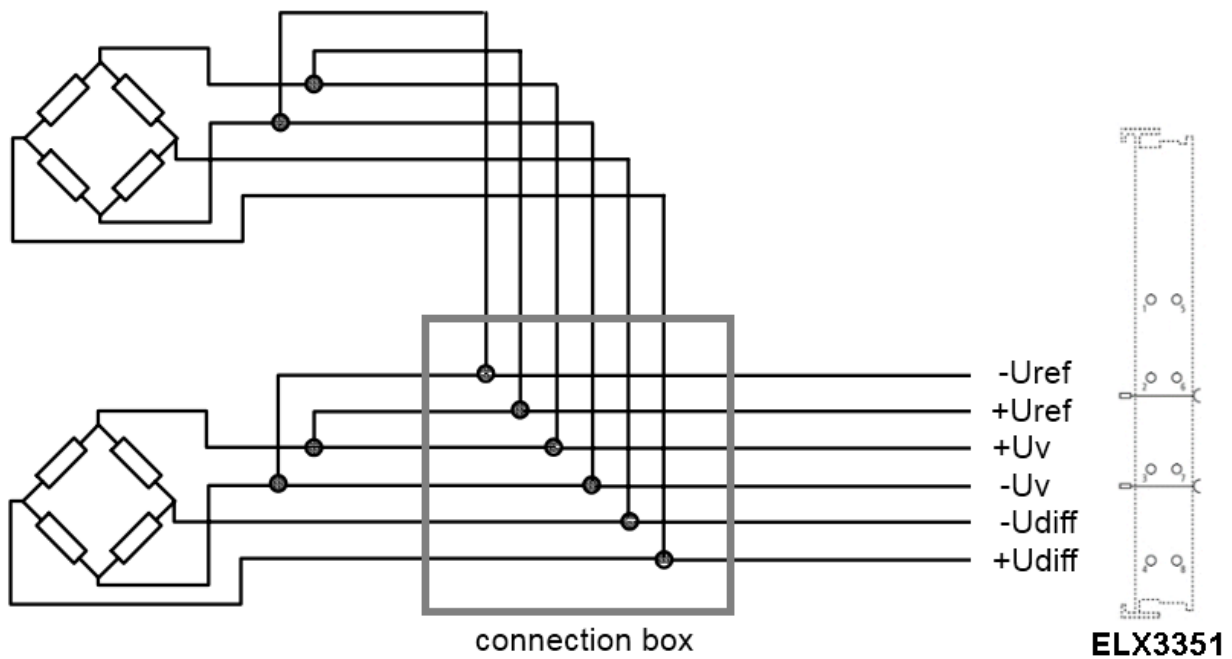

Fig. 46: Parallel connection with ELX3351

- Load cell signals have a low amplitude and are occasionally very sensitive to electromagnetic interference. Considering the typical system characteristics and taking into account the technical possibilities, purposeful state-of-the-art EMC protective measures are to be taken. If shielded cables are used, the installation measures and, if necessary, the Separation distances in accordance with IEC 60079-11 and IEC 60079-25 must be taken into account. Under high EMC interference loads, it can be helpful to remove the cable shield in front of the terminal additionally with suitable shielding material.

5.1.2 Block diagram

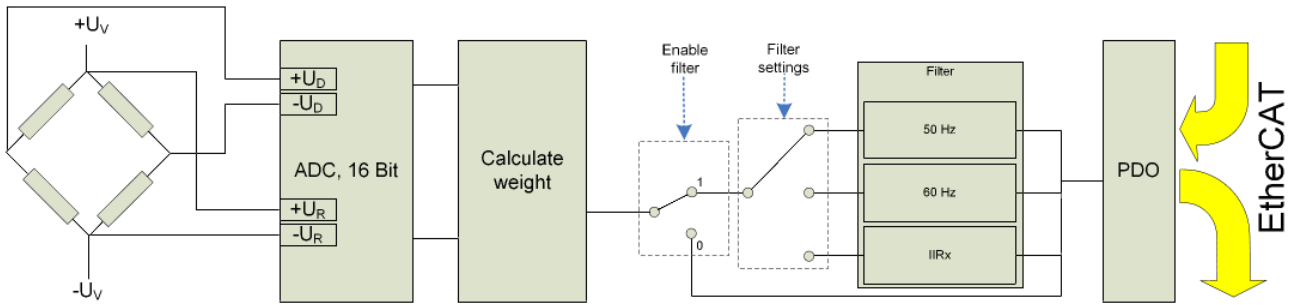

Fig. 47: ELX3351 - Block diagramm

The ELX3351 processes the data in the following order

1. Hardware low-pass 3.6 KHz
2. 2-channel simultaneous sampling by delta-sigma ($\Delta\Sigma$) converter and internal prefiltration
3. Software filter (can be deactivated)
4. Calculating the weight

● Measurement principle of delta-sigma ($\Delta\Sigma$) converter

I The measurement principle employed in the ELX3351, with real sampling in the MHz range, shifts aliasing effects into a very high frequency range, so that normally no such effects are to be expected in the KHz range.

5.1.3 Software filter

The ELX3351 is equipped with a digital software filter which, depending on its settings, can adopt the characteristics of a *Finite Impulse Response filter (FIR filter)*, or an *Infinite Impulse Response filter (IIR filter)*. The filter is activated by default as *50Hz-FIR*.

In the respective measuring mode the filter can be activated ([0x8000:01 \[▶ 71\]](#), [0x8000:02 \[▶ 71\]](#)) and parameterized ([0x8000:11 \[▶ 71\]](#), [0x8000:12 \[▶ 71\]](#)) (the ELX3351 supports only mode 0).

• FIR 50/60 Hz

The filter performs a notch filter function and determines the conversion time of the terminal. The higher the filter frequency, the faster the conversion time. A 50 Hz and a 60 Hz filter are available. Notch filter means that the filter has zeros (notches) in the frequency response at the filter frequency and multiples thereof, i.e. it attenuates the amplitude at these frequencies. The FIR filter operates as a non-recursive filter.

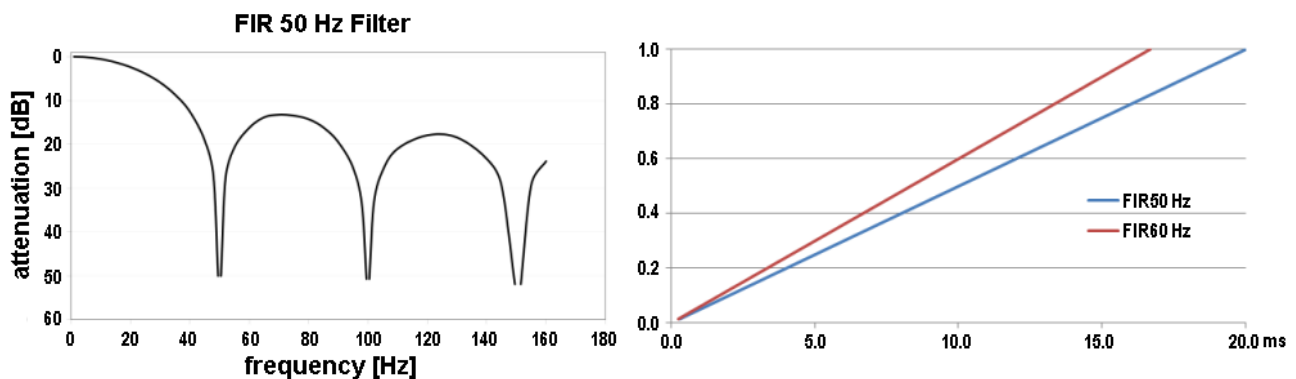

Fig. 48: Notch characteristic/amplitude curve and step response of the FIR filter

• **IIR-Filter 1 to 8**

The filter with IIR characteristics is a discrete time, linear, time invariant filter that can be set to eight levels (level 1 = weak recursive filter, up to level 8 = strong recursive filter).

The IIR can be understood to be a moving average value calculation after a low-pass filter.

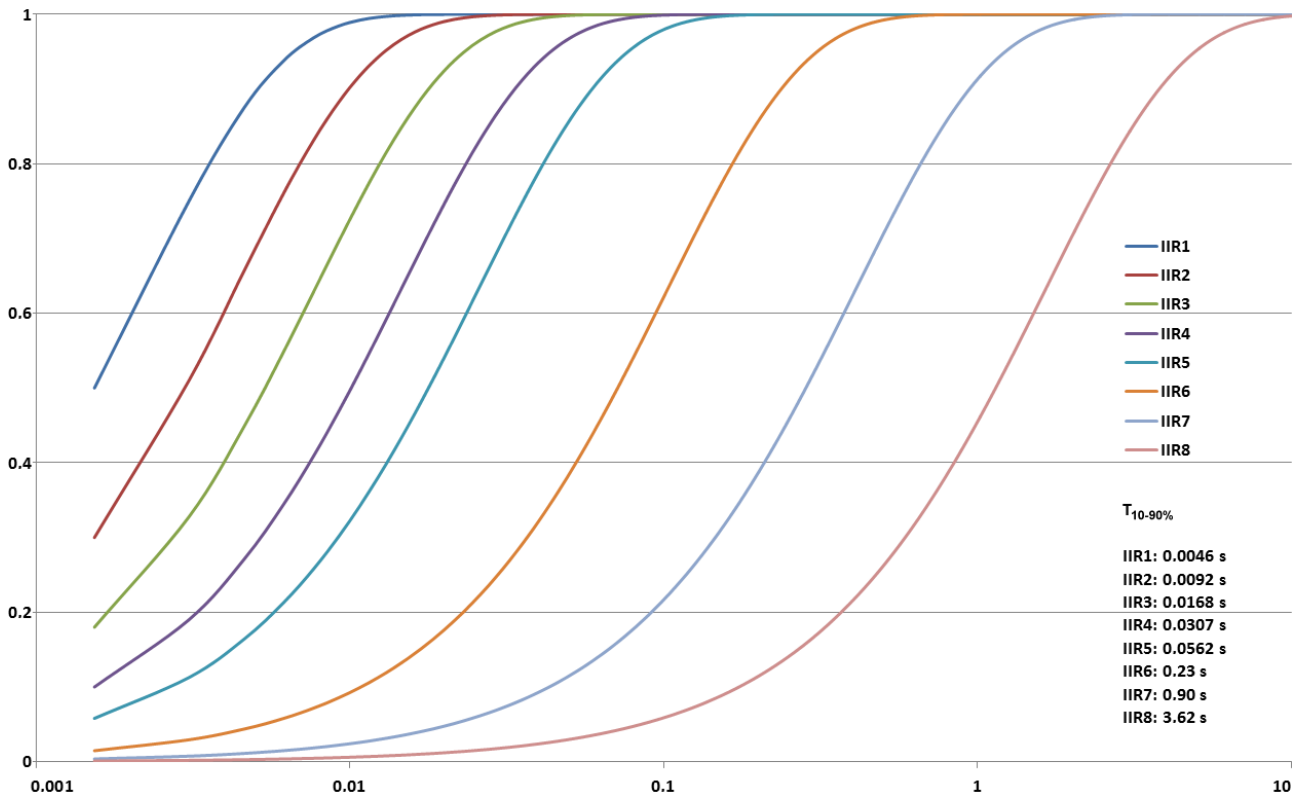

Fig. 49: Step response of the IIR filter

● **Filter and cycle time**

i If the FIR filters (50 Hz or 60 Hz) are switched on, the process data are updated maximally with the specified conversion time. (see table) The IIR filter works cycle-synchronously. Hence, a new measured value is available in each PLC cycle.

● **IIR filter**

i Differential equation: $Y_n = X_n * a_0 + Y_{n-1} * b_1$
 with $a_0 + b_1 = 1$
 $a_0 =$ (see table)
 $b_1 = 1 - a_0$

5.1.4 Dynamic filter

The dynamic IIR filter automatically switches through the 8 different IIR filters depending on the weight change. The idea:

- The target state is always the IIR8-Filter, i.e. the greatest possible damping and hence a very calm measured value.
- In the input variable changes rapidly the filter is opened, i.e. switched to the next lower filter (if still possible). This gives the signal edge more weight and the measured value curve can follow the load quickly.
- If the measured value changes very little the filter is closed, i.e. switched to the next higher filter (if still possible). Hence the static state is mapped with a high accuracy.
- The evaluation as to whether a downward change of filter is required or whether an upward change is possible takes place continuously at fixed time intervals.

Parameterization takes place via the CoE entries [0x8000:13 \[► 71\]](#) and [0x8000:14 \[► 71\]](#). Evaluation takes place according to 2 parameters:

- The "Dynamic filter change time" object ([0x8000:13 \[► 71\]](#)) is used to set the time interval at which the existing signal is re-evaluated.
- Object [0x8000:14 \[► 71\]](#) is used to specify the maximum deviation that is permissible during this time without filter switching occurring.

Example:

The dynamic filter is to be adjusted in such a manner that a maximum slope of 0.5 digits per 100 ms (5 digits per second) is possible without the filter being opened. This results in a "calm" measured value. In the case of a faster change, however, it should be possible to immediately follow the load.

- Dynamic filter change time ([0x8000:13 \[► 71\]](#)) = 10 (equivalent to 100 ms)
- Dynamic filter delta ([0x8000:14 \[► 71\]](#)) = 0.5 (related to the calculated load value)

The measured value curve is shown below for a slower (left) and faster (right) change.

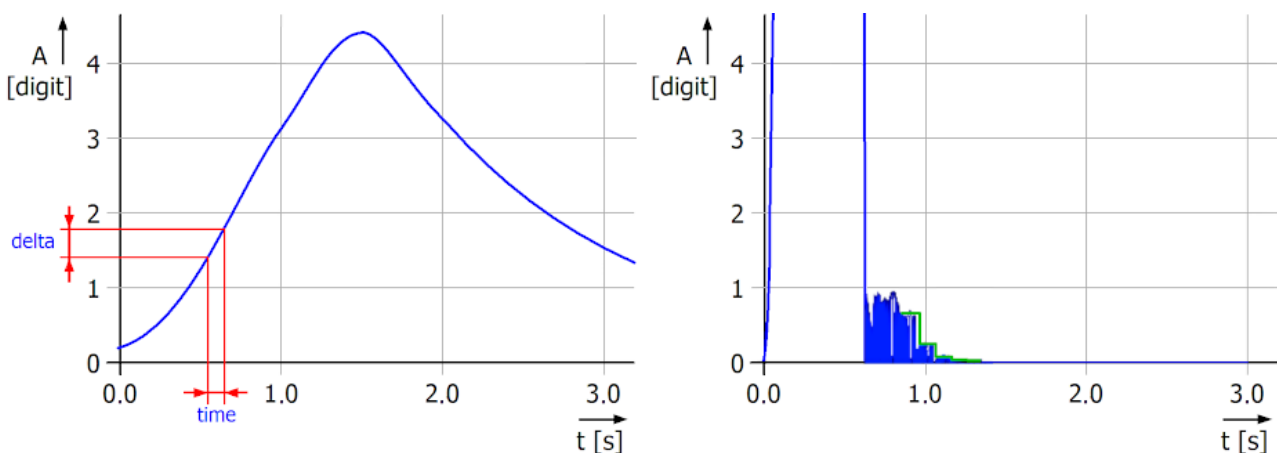

Fig. 50: Effect of dynamic IIR filters

- **Links:** The scales are slowly loaded. The change in the weight (delta/time) remains below the mark of 0.5 digits per 100 ms. The filter therefore remains unchanged at the strongest level (IIR8), resulting in a low-fluctuation measured value.
- **Right:** The scales are suddenly loaded. The change in the weight immediately exceeds the limit value of 0.5 digits per 100 ms. The filter is opened every 100 ms by one level (IIR8 --> IIR7 --> IIR6 etc.) and the display value immediately follows the jump. After the removal of the weight the signal quickly falls again. If the change in the weight is less than 0.5 digit per 100 ms, the filter is set one level stronger every 100 ms until IIR8 is reached. The green line is intended to clarify the decreasing "noise level"

5.1.5 Calculating the weight

Each measurement of the analog inputs is followed by the calculation of the resulting weight or the resulting force, which is made up of the ratio of the measuring signal to the reference signal and of several calibrations.

- $Y_R = (U_{Diff} / U_{Ref}) \times A_i$ (1.0) Calculation of the raw value in mV/V
- $Y_L = (Y_R - C_{ZB}) / (C_n - C_{ZB}) \times E_{max}$ (1.1) Calculation of the weight
- $Y_S = Y_L \cdot A_S$ (1.2) Scaling factor (e.g. factor 1000 for rescaling from kg to g)
- $Y_G = Y_S \cdot (G / 9.80665)$ (1.3) Influence of acceleration of gravity
- $Y_{AUS} = Y_G \times Gain - Tare$ (1.4) Gain and Tare

Name	Description	CoE Index
U_{Diff}	Bridge voltage/differential voltage of the sensor element, after filter	
U_{Ref}	Bridge supply voltage/reference signal of the sensor element, after filter	
A_i	Internal gain, not changeable. This factor accounts for the unit standardization from mV to V and the different full-scale deflections of the input channels	
C_n	Nominal characteristic value of the sensor element (unit mV/V, e.g. nominally 2 mV/V or 2.0234 mV/V according to calibration protocol)	0x8000:23 ▶ 71
C_{ZB}	Zero balance of the sensor element (unit mV/V, e.g. -0.0142 according to calibration protocol)	0x8000:25 ▶ 71
E_{max}	Nominal load of the sensor element	0x8000:24 ▶ 71
A_S	Scaling factor (e.g. factor 1000 for rescaling from kg to g)	0x8000:27 ▶ 71
G	Acceleration of gravity in m/s ² (default: 9.80665 ms/s ²)	0x8000:26 ▶ 71
Gain		0x8000:21 ▶ 71
Tare		0x8000:22 ▶ 71

5.2 Application notes

5.2.1 Wiring fail indication

The ELX3351 has no express open-circuit recognition facility. If one of the bridge wires is broken, however, the voltage measured there generally moves towards the final value, thus displaying an error in the status word. Over/underrange of the supply voltage is likewise indicated.

5.2.2 InputFreeze

If the terminal is placed in the freeze state by *InputFreeze* in the control word, no further analog measured values are relayed to the internal filter. This function is usable, for example, if a filling surge is expected from the application that would unnecessarily overdrive the filters due to the force load. This would result in a certain amount of time elapsing until the filter had settled again. The user himself must determine a sensible *InputFreeze* time for his filling procedure.

For clarification: temporal control of the *InputFreeze* and the decision regarding its use must be realized by the user in the PLC, they are not components of the ELX3351.

In the following example (recorded with Scope2) impulses on a 15 kg load cell are recorded; the filter is wide open at IIR1 so that steep edges occur in the signal.



Fig. 51: InputFreeze example

Explanation: The weight (A) is shown in blue; the state of the *InputFreeze* variable, which can be controlled by the PLC program and can be TRUE/FALSE, is shown in red (B). The first two impulses (C) lead to large peak deflections in the signal. After that the following is activated in the PLC program (see example program):

- if the measured value for the last cycle (cycle time 100 μ s) has changed by more than 10 g (indicating a sudden load),
- *blInputFreeze* is set to TRUE for 50 ms by a TOF block on the ELX3351

The effect can be seen in (D): The peak load is no longer acknowledged by the ELX3351. If it is optimally adapted to the expected force impulse, the ELX3351 can measure the current load value without overshoot.

5.2.3 Gravity adaptation

The calculation of the weight depends on the gravitation/the Earth's gravitational force/acceleration due to gravity at the place of installation of the scales. In general, acceleration due to the gravitational pull of the earth at the place of installation is not equal to the defined standard value of $g = 9.80665 \text{ m/s}^2$. For example, 4 zones of acceleration due to gravity are defined in Germany, in which a local acceleration due to gravity of 9.807 to 9.813 m/s^2 is to be assumed. Hence, within Germany alone there is a clear dispersion of the order of parts per thousand for acceleration due to gravity, which has a direct effect on the measured weight in accordance with the equation $F_G = m \cdot g!$

If

- load cells are used in the theoretical calibration with characteristic values according to the sensor certificate
- calibration weights are used whose weight at the place of installation of the scales is by nature different to that at the place of origin
- scales of the accuracy class I to III are to be realized
- scales that are generally independent of acceleration due to gravity are to be realized

then one should check whether the gravity correction needs to be adapted via object [0x8000:26](#) [▶ 71](#)].

5.2.4 Idling recognition

Weighing is a dynamic procedure that can lead to large jumps in the bridge voltage and thus to the calculation of the value. Following a change in load, the measured value must first "settle" so that the process value is evaluable in the controller. The evaluation of the measured value and the decision over the degree of calmness can be done in the controller; however, the ELX3351 also offers this function, which is activated by default. The result is output in the status word.

- If the load value remains within a range of values y for longer than time x , then the *SteadyState* is activated in the *StatusWord*.
- *SteadyState* is set to FALSE as soon as this condition no longer applies.
- The parameters x and y can be specified in the CoE
- The evaluation is naturally considerably affected by the filter setting

In the following example (recorded with TwinCAT Scope2), a 15 kg load cell is suddenly unloaded and loaded with 547 g. *SteadyState* is subject to a window time from 100 ms and a tolerance of 8 g (15 kg nominal value, scaling 1000; see CoE).

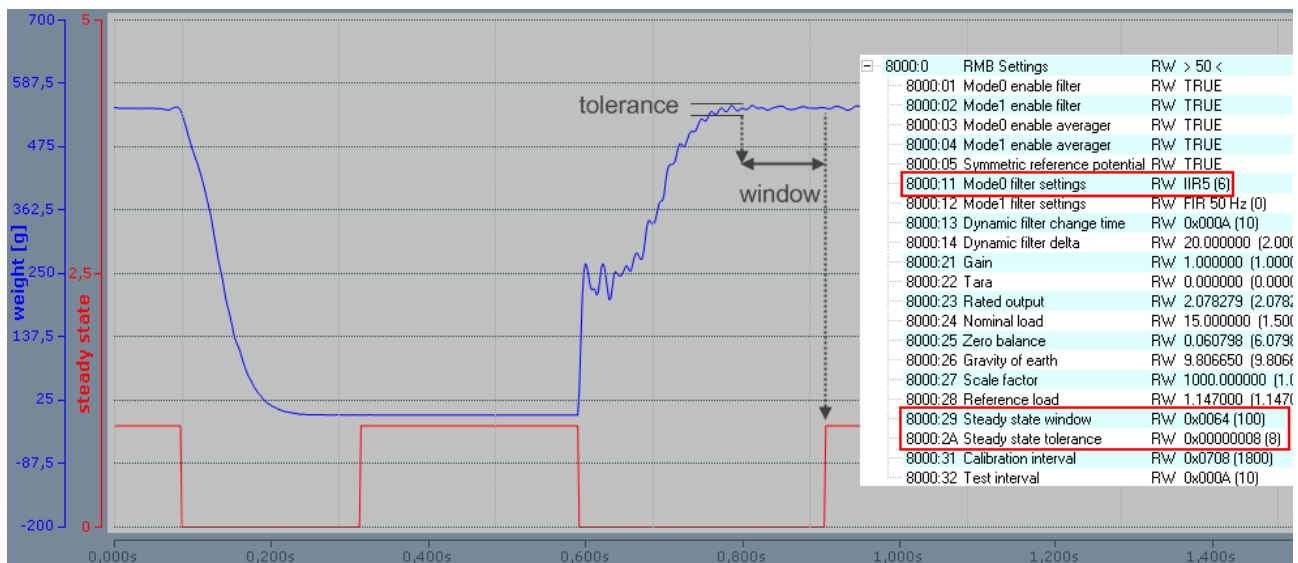

Fig. 52: Idling recognition example

5.2.5 Official calibration capability

"Official calibration" is a special kind of calibration that is accomplished according to special regulations with the involvement of trained personnel using prescribed aids. The use of "officially calibrated" scales is mandatory in the Central European region, in particular for the filling of foodstuffs. This ensures the correctness of the weighed quantities in a particular way.

The ELX3351 terminals cannot be officially calibrated as individual devices. However, they can be integrated as elements in applications that can then be equipped by the integrator with the required characteristics for official calibration capability using appropriate means.

5.3 Calibration and compensation

The term "calibration" can be applied in 3 different ways to the ELX3351:

- Sensor calibration: once-only calibration of the employed sensor (strain gauge) during commissioning of the system
- Self-calibration: continuously repeated self-calibration of the terminal for the improvement of the measuring accuracy
- Tare: repeated gross/net compensation by taring

5.3.1 Sensor calibration

The ELX3351 is matched to the characteristic curve of the sensor element by means of the calibration. Two values are required for this procedure: the initial value without a load (zero balance) and fully loaded (rated output). These values can be determined by a calibration protocol or by a calibration using calibration weights.

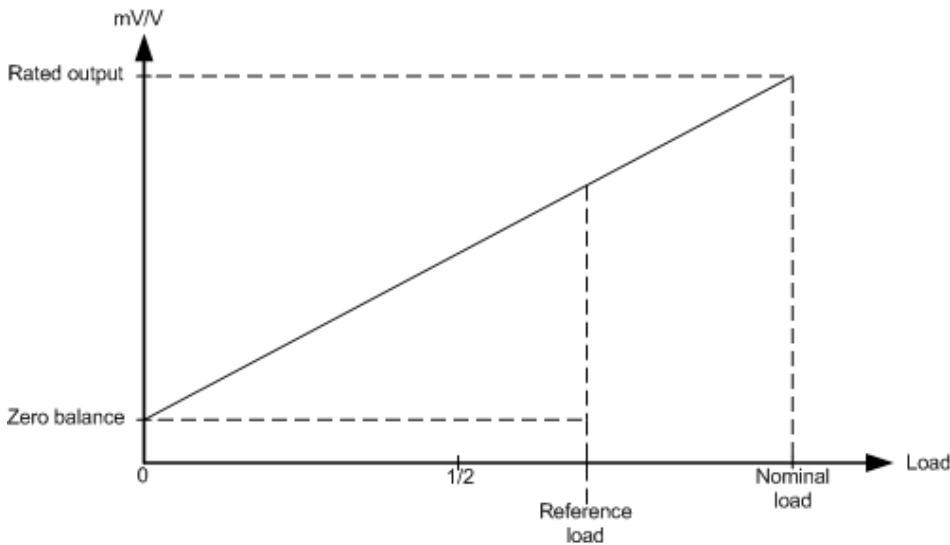

Fig. 53: Adaptation to the sensor curve

Calibration by means of compensation in the system

In the practical calibration, measurement takes place first with the scales unloaded, then with a defined load on the scales. The ELX3351 automatically calculates the existing sensor characteristic values from the measured values.

Sequence:

1. Perform a CoE reset with object 0x1011:01
see Restoring the delivery state
2. Activate mode 0 via the control word
3. Set scale factor to 1 (0x8000:27 [► 71])
4. Set gravity of earth (0x8000:26 [► 71]) if necessary (default: 9.806650)
5. Set gain to (0x8000:21 [► 71]) = 1
6. Set tare to 0 (0x8000:22 [► 71])
7. Set the filter (0x8000:11 [► 71]) to the strongest level: IIR8
8. Specify the nominal load of the sensor in 0x8000:24 [► 71] ("Nominal load")
9. Zero balance: Do not load the scales
As soon as the measured value indicates a constant value for at least 10 seconds, execute the command 0x0101 (257_{dec}) on CoE object 0xFB00:01.
This command causes the current mV/V value (0x9000:11 [► 72]) to be entered in the "Zero balance" object.
Check: CoE objects FB00:02 and FB00:03 must contain "0" after execution

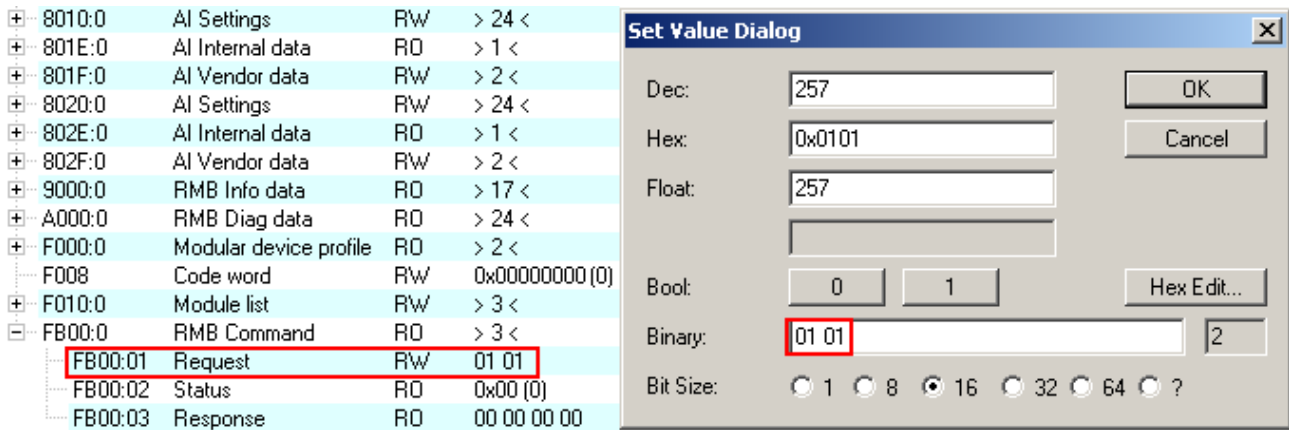

Fig. 54: Zero calibration with command 0x0101 in CoE object 0xFB00:01

- Load the scales with a reference load. This should be at least 20% of the rated load. The larger the reference load, the better the sensor values can be calculated.

In object 0x8000:28 [▶ 71] ("Reference load"), enter the load in the same unit as the rated load (0x8000:24 [▶ 71]).

As soon as the measured value indicates a constant value for at least 10 seconds, execute the command "0x0102" (258_{dec}) on CoE object 0xFB00:01.

By means of this command the ELX3351 determines the output value for the nominal weight ("Rated output")

Check: CoE objects FB00:02 and FB00:03 must contain "0" after execution

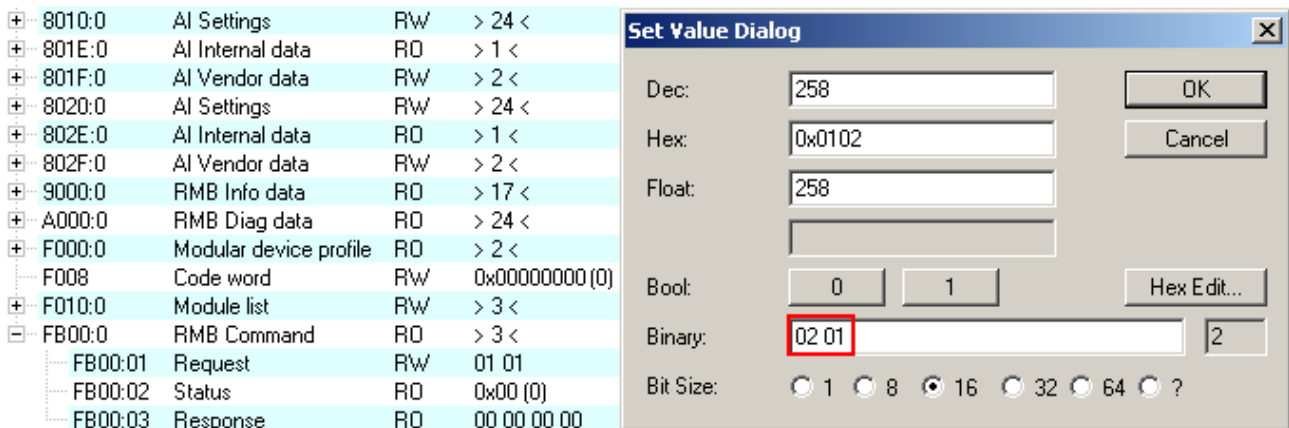

Fig. 55: Loading with reference load, command 0x0102 in CoE object 0xFB00:01

- Reset: execute the command 0x0000 (0_{dec}) on CoE object 0xFB00:01.
- Set the filter to a lower stage.

Calibration according to the sensor calibration protocol (theoretical calibration)

The sensor characteristic values according to the manufacturer's certificate are communicated here directly to the ELX3351, so that it can calculate the load.

- Execute a CoE reset
- Set scale factor to 1 (0x8000:27 [▶ 71])
- Set gravity of earth (0x8000:26 [▶ 71]) if necessary (default: 9.806650)
- Ste gain to (0x8000:21 [▶ 71]) = 1
- Set tare to 0 (0x8000:22 [▶ 71])
- Specify the nominal load of the sensor in 0x8000:24 [▶ 71] (Nominal load)
- Adopt the "Rated output" (mV/V value 0x8000:23 [▶ 71]) from the calibration protocol
- Adopt the "Zero balance" (0x8000:25 [▶ 71]) from the calibration protocol

● Calibration

i The calibration is of great importance for the accuracy of the system. In order to increase this, the filter should be set as strong as possible over the entire calibration phase. It may take several seconds before a static value is obtained.

● Local storage

i The values modified during the theoretical and practical calibration are stored in a local EEPROM. This can be written to up to 1 million times. In order to prolong the life of the EEPROM, therefore, the commands should not be executed cyclically.

5.3.2 Self-calibration

Self-calibration of the measuring amplifiers

The measuring amplifiers are periodically subjected to examination and self-calibration. Several analog switches are provided for this purpose, so that the various calibration signals can be connected. It is important for this process that the entire signal path, including all passive components, is examined at every phase of the calibration. Only the interference suppression elements (L/C combination) and the analog switches themselves cannot be examined. In addition, a self-test is carried out at longer intervals.

The self-calibration is carried out every 3 minutes in the default setting.

- **Self-calibration**

The time interval is set in 100 ms steps with object `0x8000:31 [▶ 71]`; default: 3 min.
Duration approx. 150 ms

By means of the self-calibration of the input stages at the two operating points (zero point and final value), the two measuring channels are calibrated to each other.

Interface for controller

The self-calibration takes place automatically at the defined intervals. In order to prevent calibration during a time-critical measurement, the automatic calibration can be disabled permanently via the *Disable calibration* bit in *ControlWord*. If it should be additionally necessary to carry out a manual test, this is started by a rising edge of the *Start manual calibration* bit in the process image.

While the terminal is performing a self-calibration, the *Calibration in progress* bit is set in the process image. Once started, a self-calibration cannot be aborted.

If the self-calibration has been disabled by *Disable calibration*, it can nevertheless be started by the *Start calibration* process data bit.

● Self-calibration

i The self-calibration takes place for the first time directly after starting up the terminal. At this point the supply voltage must already be applied. If the supply voltage is only applied later, the self-calibration must be manually initiated (process data bit: *Start calibration*).

The self-calibration must be executed at least once after each start-up.

A lower measuring accuracy is expected if the self-calibration is disabled for a longer period or permanently.

After a change in the CoE settings (section x80nn), a self-calibration is always performed (even if *DisabledCalibration* = TRUE), since the settings affect the measurement. Changing the CoE settings during an ongoing measurement should therefore be avoided, if possible.

5.3.3 Taring

When taring, the scales are zeroed using an arbitrary applied load; i.e. an offset correction is performed. This is necessary for the gross/net compensation of goods that cannot be weighed without a container that has a mass of its own.

It is recommended to set a strong filter when taring.

Temporary tare

A rising edge on the Tare PDO can be used to execute a temporary tare. The correction value is NOT stored in the terminal and is lost in the event of a power failure. This sets the tare object (0x8000:22 [▶ 71]) such that the display value is 0.

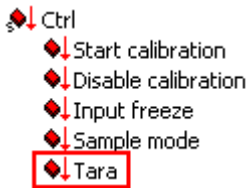

Fig. 56: Control word, tare

5.3.4 Overview of commands

The functions described above are carried out by means of commands in the standardized object 0xFB00.

Index	Name	Comment
FB00:01	Request	Entry of the command to be executed
FB00:02	Status	Status of the command currently being executed 0: Command executed without error. 255: Command is being executed
FB00:03	Response	Optional response value of the command

The function blocks *FB_EcCoESdoWrite* and *FB_EcCoESdoRead* from the *TcEtherCAT.lib* (contained in the standard TwinCAT installation) can be used in order to execute the commands from the PLC.

Commands of the ELX3351

The following commands can be transferred to the terminal via the CoE entry 0xFB00:01.

Command	Comment
0x0101	Execute zero balance
0x0102	Execute calibration

5.4 Process data

This section describes the individual PDOs and their content. A PDO (Process Data Object) is a unit on cyclically transmitted process values. Such a unit can be an individual variable (e.g. the weight as a 32-bit value) or a group/structure of variables. The individual PDOs can be activated or deactivated separately in the TwinCAT System Manager. The 'Process data' tab is used for this (visible only if the terminal is selected on the left). A change in the composition of the process data in the TwinCAT System Manager becomes effective only after restarting the EtherCAT system.

5.4.1 Selection of process data

The process data of the ELX3351 are set up in the TwinCAT System Manager. The PDOs can be activated or deactivated separately. The 'Process data' tab is used for this (visible only if the terminal is selected on the left).

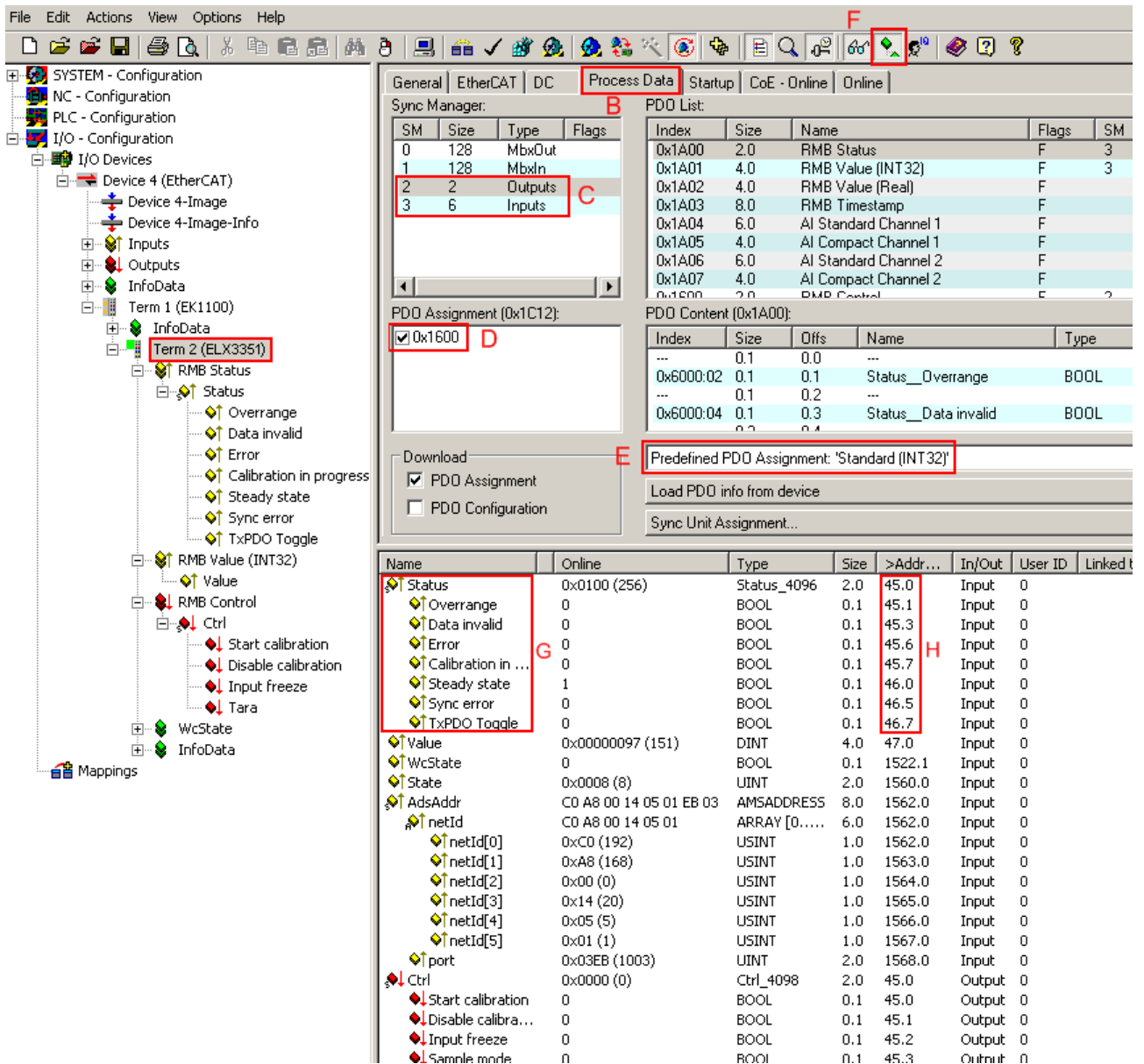

Fig. 57: ELX3351 - process data selection in the TwinCAT System Manager

If the terminal is selected in the System Manager (A), the *Process data* tab (B) shows the PDO selection. The two SyncManagers of the inputs (SM3) and outputs (SM2) can be changed (C). If one of the two is clicked on, the PDO possible for this SyncManager appears underneath it (D). PDOs that are already activated have an activated checkbox in front of them; this is activated by clicking on it.

The process data which then belong to the device are listed underneath it (G). So that the individual bit meanings are visible, e.g. in the *Status* status word, and can be separately linked (G), *ShowSubVariables* must be activated in the System Manager (F). The bit position at which the subvariables are located in the status or control word *Ctrl*) can be taken from the address overview (H) or the following information.

Predefined PDO Assignment

In order to simplify the configuration, typical configuration combinations of process data are stored in the device description. The predefined configurations can be selected in the process data overview. Therefore the function is available only if the ESI/XML files are saved in the system (download from the Beckhoff website).

The following combinations are possible (see also Fig. *ELX3351 process data selection in the TwinCAT System Manager*, E):

Predefined PDO Assignment: 'Standard (INT32)'
Predefined PDO Assignment: (none)
Predefined PDO Assignment: 'Standard (INT32)'
Predefined PDO Assignment: 'Standard (REAL)'

Fig. 58: ELX3351 - selection Predefined PDO Assignment

- Standard (INT32): [Default setting] load calculation; 32-bit integer load value as final value according to the calculation specifications in the CoE, no further conversion necessary in the PLC.
- Standard (REAL): Load calculation; 32-bit floating-point load value as final value according to the calculation specifications in the CoE, no further conversion necessary in the PLC.

5.4.2 Default process image

The default process image is standard (INT32).

Name	Online	Type	Size	>Addr...	In/Out	User ID
↕↑ Status	0x8100 (33024)	Status_4096	2.0	45.0	Input	0
↕↑ Overrange	0	BOOL	0.1	45.1	Input	0
↕↑ Data invalid	0	BOOL	0.1	45.3	Input	0
↕↑ Error	0	BOOL	0.1	45.6	Input	0
↕↑ Calibration in progress	0	BOOL	0.1	45.7	Input	0
↕↑ Steady state	1	BOOL	0.1	46.0	Input	0
↕↑ Sync error	0	BOOL	0.1	46.5	Input	0
↕↑ TxPDO Toggle	1	BOOL	0.1	46.7	Input	0
↕↑ Value	0x00000097 (151)	DINT	4.0	47.0	Input	0
↕↑ WcState	0	BOOL	0.1	1522.1	Input	0
↕↑ State	0x0008 (8)	UINT	2.0	1560.0	Input	0
↕↑ AdsAddr	C0 A8 00 14 05 01 EB 03	AMSADDRESS	8.0	1562.0	Input	0
↕↑ netId	C0 A8 00 14 05 01	ARRAY [0.....	6.0	1562.0	Input	0
↕↑ netId[0]	0xC0 (192)	USINT	1.0	1562.0	Input	0
↕↑ netId[1]	0xA8 (168)	USINT	1.0	1563.0	Input	0
↕↑ netId[2]	0x00 (0)	USINT	1.0	1564.0	Input	0
↕↑ netId[3]	0x14 (20)	USINT	1.0	1565.0	Input	0
↕↑ netId[4]	0x05 (5)	USINT	1.0	1566.0	Input	0
↕↑ netId[5]	0x01 (1)	USINT	1.0	1567.0	Input	0
↕↑ port	0x03EB (1003)	UINT	2.0	1568.0	Input	0
↕↓ Ctrl	0x0000 (0)	Ctrl_4098	2.0	45.0	Output	0
↕↓ Start calibration	0	BOOL	0.1	45.0	Output	0
↕↓ Disable calibration	0	BOOL	0.1	45.1	Output	0
↕↓ Input freeze	0	BOOL	0.1	45.2	Output	0
↕↓ Sample mode	0	BOOL	0.1	45.3	Output	0
↕↓ Tara	0	BOOL	0.1	45.4	Output	0

Fig. 59: ELX3351 - Default process image

Note regarding ELX3351: No switching of *SampleMode* in the Ctrl word

Function of the variables

Variable	Meaning
Status	The status word (SW) is located in the input process image, and is transmitted from terminal to the controller. For explanation see the entries in the object overview, index 0x6000 [▶ 72] see "Bit - meaning of the status word [▶ 68]"
Value	calculated 32-bit DINT load value in unit [1], with sign
Value (Real)	calculated 32-bit floating point REAL load value with mantissa and exponent in unit [1] The format matches the REAL format of IEC 61131-3, which in turn is based on the REAL format of IEC 559. A REAL number (single precision) is defined as follows (See also Beckhoff InfoSys: TwinCAT PLC Control: standard data types). According to IEC 61131, this 32-bit variable can be linked directly with a FLOAT variable of the PLC, see "Bit - meaning of the variable value (REAL) [▶ 68]"
WcState	cyclic diagnostic variable; "0" indicates correct data transmission
Status	State of the EtherCAT device; <i>State.3</i> = TRUE indicates correct operation in OP
AdsAddr	AmsNet address of the EtherCAT device from AmsNetId (in this case: 192.168.0.20.5.1) and port (in this case: 1003)
Ctrl	The control word (CW) is located in the output process image, and is transmitted from the controller to the terminal. For explanation see the entries in the object overview, index 0x7000 [▶ 72] see "Bit - meaning of the control word [▶ 68]"

See also the example program for the dissection of the Status and CTRL variable.

Bit - meaning of the Status Word

Bit	SW.15	SW.14	SW.13	SW.12 - SW.9	SW.8	SW.7	SW.6	SW.5 - SW.4	SW.3	SW.2	SW.1	SW.0
Name	TxPDO Toggle	-	-	-	Steady State	Calibration in progress	Error	-	Data invalid	-	Over-range	-
Meaning	toggleles 0->1->0 with each updated data set	-	-	-	Idling recognition	Calibration in progress	Collective error display	-	Input data are invalid	-	Measuring range exceeded	-

Bit - purpose of the variable Value (Real)

Bit position (from left)	1	8	23 (+1 "hidden bit", see IE559)
Function	Sign	Exponent	Mantissa

Bit - meaning of the Control Word

Bit	CW.15 - CW.5	CW.4	CW.3	CW.2	CW.1	CW.0
Name	-	Tare	-	Input Freeze	Disable Calibration	Start Calibration
Meaning	-	starts tare	-	stops the measurement	switches the automatic self-calibration off	starts the self-calibration immediately

5.4.3 Variants Predefined PDO

Floating-point representation of the load

The display of the load value can also be converted already in the terminal into a point representation. To do this the input PDOs are to be changed as follows:

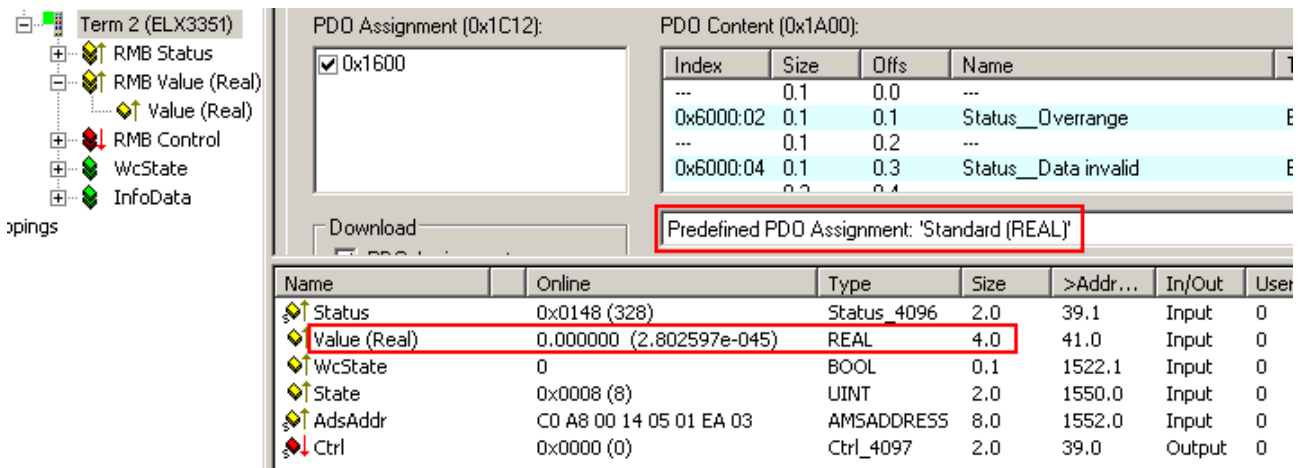

Fig. 60: Load value in floating-point representation

Variable	Meaning
Value (Real)	calculated 32-bit floating point REAL load value with mantissa and exponent in unit [1] The format matches the REAL format of IEC 61131-3, which in turn is based on the REAL format of IEC 559. A REAL number (single precision) is defined as follows (See also Beckhoff InfoSys: TwinCAT PLC Control: standard data types). According to IEC61131, this 32-bit variable can be linked directly with a FLOAT variable of the PLC, see "Bit – meaning of the variable value (REAL)"

5.4.4 Sync Manager

PDO Assignment

Inputs: SM3, PDO Assignment 0x1C13				
Index	Index of excluded PDOs	Size (byte.bit)	Name	PDO content
0x1A00 (default)	-	2.0	RMB Status (Resistor Measurement Bridge)	Index 0x6000:02 [▶ 72] - Overrange Index 0x6000:04 [▶ 72] - Data invalid Index 0x6000:07 [▶ 72] - Error Index 0x6000:08 [▶ 72] - Calibration in progress Index 0x6000:09 [▶ 72] - Steady State Index 0x6000:10 [▶ 72] - TxPDO Toggle
0x1A01 (default)	0x1A02 0x1A04 0x1A05 0x1A06 0x1A07	4.0	RMB Value (INT32)	Index 0x6000:11 [▶ 72] - Value
0x1A02	0x1A01 0x1A04 0x1A05 0x1A06 0x1A07	4.0	RMB Value (Real)	Index 0x6000:12 [▶ 72] - Value (Real)

Outputs: SM2, PDO assignment 0x1C12				
Index	Index of excluded PDOs	Size (byte.bit)	Name	PDO content
0x1600 (default)	-	2.0	RMB Control (Resistor Measurement bridge)	Index 0x7000:01 [▶ 72] - Start calibration Index 0x7000:02 [▶ 72] - Disable calibration Index 0x7000:03 [▶ 72] - Input freeze Index 0x7000:05 [▶ 72] - Tare

5.5 ELX3351 - Object description

● EtherCAT XML Device Description



The display matches that of the CoE objects from the EtherCAT XML Device Description. We recommend downloading the latest [XML file](#) from the download area of the [Beckhoff website](#) and installing it according to installation instructions.

● Parameterization via the CoE list (CAN over EtherCAT)



The EtherCAT device is parameterized via the CoE-Online tab (double-click on the respective object) or via the Process Data tab (allocation of PDOs). Please note the following general CoE notes when using/manipulating the CoE parameters:

- Keep a startup list if components have to be replaced
- Differentiation between online/offline dictionary, existence of current XML description
- use “CoE reload” for resetting changes

5.5.1 Restore object

Index 1011 Restore default parameters

Index (hex)	Name	Meaning	Data type	Flags	Default
1011:0	Restore default parameters	Restore default parameters	UINT8	RO	0x01 (1 _{dec})
1011:01	SubIndex 001	If this object is set to “ 0x64616F6C ” in the set value dialog, all backup objects are reset to their delivery state.	UINT32	RW	0x00000000 (0 _{dec})

5.5.2 Configuration data

Index 8000 RMB Settings

Index (hex)	Name	Meaning	Data type	Flags	Default
8000:0	RMB Settings	Max. subindex	UINT8	RO	0x32 (50 _{dec})
8000:01	Enable filter	0: No filters active. The terminal operates cycle-synchronous 1: The filter settings selected in subindex 0x8000:11 or 0x8000:12 are active.	BOOLEAN	RW	0x01 (1 _{dec})
8000:11	Filter settings	0: FIR 50 Hz 1: FIR 60 Hz 2: IIR 1 3: IIR 2 4: IIR 3 5: IIR 4 6: IIR 5 7: IIR 6 8: IIR 7 9: IIR 8 10: Dynamic IIR	UINT16	RW	0x0000 (0 _{dec})
8000:13	Dynamic filter change time	Sampling rate for dynamic filter switching. Scaling in 0.01 ms (100 = 1 s) (only if the filters are active and "dynamic IIR" is selected as filter)	UINT16	RW	0x000A (10 _{dec})
8000:14	Dynamic filter delta	Limit value for dynamic filter switching. (only if the filters are active and "dynamic IIR" is selected as filter)	REAL32	RW	0x41A00000 (1101004800 _{dec}) = 20.0
8000:21	Gain	Scale factor	REAL32	RW	0x3F800000 (1065353216 _{dec}) = 1.0
8000:22	Tare	Process data value offset	REAL32	RW	0x00000000 (0 _{dec}) = 0.0
8000:23	Rated output	Nominal characteristic value of the sensor element in mV/V	REAL32	RW	0x40000000 (1073741824 _{dec}) = 2.0
8000:24	Nominal load	Nominal load of the force transducer/load cell/etc. (e.g. in kg, N or ...)	REAL32	RW	0x40A00000 (1084227584 _{dec}) = 5.0
8000:25	Zero balance	Zero point offset in mV/V	REAL32	RW	0x00000000 (0 _{dec}) = 0.0
8000:26	Gravity of earth	Current acceleration of gravity (default 9.806650)	REAL32	RW	0x411CE80A (1092413450 _{dec}) = 9.806650
8000:27	Scale factor	This factor can be used to re-scale the process data. In order to change the display from kg to g, for example, the factor 1000 can be entered here.	REAL32	RW	0x447A0000 (1148846080 _{dec}) = 1000.0
8000:28	Reference load	Reference weight for manual calibration	REAL32	RW	0x40A00000 (1084227584 _{dec}) = 5.0
8000:29	Steady state window	Time constant for the "steady state" bit (used for idle recognition)	UINT16	RW	0x03E8 (1000 _{dec})
8000:2A	Steady state tolerance	Tolerance window for the "steady state" bit	UINT32	RW	0x00000005 (5 _{dec})
8000:31	Calibration interval	Calibration interval for automatic calibration of the terminal. The unit is 100 ms. The smallest possible value is 5 (500 ms). A value of 0 deactivates automatic self-calibration. This is also possible via the process data bit "Disable calibration".	UINT16	RW	0x0708 (1800 _{dec})

5.5.3 Command object

Index FB00 RMB Command

Index (hex)	Name	Meaning	Data type	Flags	Default
FB00:0	RMB Command	Max. subindex	UINT8	RO	0x03 (3 _{dec})
FB00:01	Request	Commands can be sent to the terminal via the request object. Command: <ul style="list-style-type: none"> • 0x0101: Zero balance • 0x0102: Calibration see commands	OCTET-STRING[2]	RW	{0}
FB00:02	Status	Status of the command currently being executed 0: Command executed without error. 255: Command is being executed	UINT8	RO	0x00 (0 _{dec})
FB00:03	Response	Optional response value of the command	OCTET-STRING[4]	RO	{0}

5.5.4 Input data

Index 6000 RMB Inputs

Index (hex)	Name	Meaning	Data type	Flags	Default
6000:0	RMB Inputs	Max. Subindex	UINT8	RO	0x13 (19 _{dec})
6000:02	Overrange	The measured value has reached its end value	BOOLEAN	RO	0x00 (0 _{dec})
6000:04	Data invalid	The displayed process data are invalid. e.g. during calibration.	BOOLEAN	RO	0x00 (0 _{dec})
6000:07	Error	An error has occurred.	BOOLEAN	RO	0x00 (0 _{dec})
6000:08	Calibration in progress	Calibration is running. The process data show the last valid measured value.	BOOLEAN	RO	0x00 (0 _{dec})
6000:09	Steady state		BOOLEAN	RO	0x00 (0 _{dec})
6000:10	TxPDO Toggle	The TxPDO toggle is toggled by the slave when the data of the associated TxPDO is updated.	BOOLEAN	RO	0x00 (0 _{dec})
6000:11	Value	Measured value as 32 bit signed integer	INT32	RO	0x61746144 (1635017028 _{dec})
6000:12	Value (Real)	Measured value as real	REAL32	RO	0x00000000 (0 _{dec})

5.5.5 Output data

Index 7000 RMB Outputs

Index (hex)	Name	Meaning	Data type	Flags	Default
7000:0	RMB Outputs	Max. subindex	UINT8	RO	0x05 (5 _{dec})
7000:01	Start calibration	The calibration can be started manually with a rising edge. This can be used to prevent the calibration from starting automatically at an unsuitable time.	BOOLEAN	RO	0x00 (0 _{dec})
7000:02	Disable calibration	0: Automatic calibration is active. 1: Automatic calibration is switched off.	BOOLEAN	RO	0x00 (0 _{dec})
7000:03	Input freeze	The process data and the digital filters are frozen.	BOOLEAN	RO	0x00 (0 _{dec})
7000:05	Tare	The process record can be set to 0 with a rising edge. The tare value is not stored in the EEPROM and is therefore no longer available after a terminal reset.	BOOLEAN	RO	0x00 (0 _{dec})

5.5.6 Information / diagnostic data

Index 9000 RMB Info data

Index (hex)	Name	Meaning	Data type	Flags	Default
9000:0	RMB Info data	Max. subindex	UINT8	RO	0x11 (17 _{dec})
9000:11	mV/V	Current mV/V value	REAL32	RO	0x00000000 (0 _{dec})

Index A000 RMB Diag data

Index (hex)	Name	Meaning	Data type	Flags	Default
A000:13	No external reference supply	The external reference voltage is less than ± 1 V.	BOOLEAN	RO	0x00 (0 _{dec})
A000:15	Overrange bridge	Measuring range exceeded in the bridge junction	BOOLEAN	RO	0x00 (0 _{dec})
A000:16	Underrange bridge	Value below measuring range in the bridge junction	BOOLEAN	RO	0x00 (0 _{dec})
A000:17	Overrange supply	Measuring range of the reference voltage exceeded	BOOLEAN	RO	0x00 (0 _{dec})
A000:18	Underrange supply	Value below measuring range for the reference voltage	BOOLEAN	RO	0x00 (0 _{dec})
A000:21	ADC raw value supply	ADC raw value bridge supply voltage	INT32	RO	0x00 (0 _{dec})
A000:22	ADC raw value bridge	ADC raw value bridge voltage	INT32	RO	0x00 (0 _{dec})

5.5.7 Standard objects

Index 1000 Device type

Index (hex)	Name	Meaning	Data type	Flags	Default
1000:0	Device type	Device type of the EtherCAT slave: the Lo-Word contains the CoE profile used (5001). The Hi-Word contains the module profile according to the modular device profile.	UINT32	RO	0x01681389 (23597961 _{dec})

Index 1008 Device name

Index (hex)	Name	Meaning	Data type	Flags	Default
1008:0	Device name	Device name of the EtherCAT slave	STRING	RO	ELX3351

Index 1009 Hardware version

Index (hex)	Name	Meaning	Data type	Flags	Default
1009:0	Hardware version	Hardware version of the EtherCAT slave	STRING	RO	00

Index 100A Software version

Index (hex)	Name	Meaning	Data type	Flags	Default
100A:0	Software version	Firmware version of the EtherCAT slave	STRING	RO	01

Index 1018 Identity

Index (hex)	Name	Meaning	Data type	Flags	Default
1018:0	Identity	Information for identifying the slave	UINT8	RO	0x04 (4 _{dec})
1018:01	Vendor ID	Vendor ID of the EtherCAT slave	UINT32	RO	0x00000002 (2 _{dec})
1018:02	Product code	Product code of the EtherCAT slave	UINT32	RO	0x0D1C3052 (219951186 _{dec})
1018:03	Revision	Revision number of the EtherCAT slave; the low word (bit 0-15) indicates the special terminal number, the high word (bit 16-31) refers to the device description	UINT32	RO	0x00100000 (1048576 _{dec})
1018:04	Serial number	Serial number of the EtherCAT slave; the low byte (bit 0-7) of the low word contains the year of production, the high byte (bit 8-15) of the low word contains the week of production, the high word (bit 16-31) is 0	UINT32	RO	0x00000000 (0 _{dec})

Index 10F0 Backup parameter handling

Index (hex)	Name	Meaning	Data type	Flags	Default
10F0:0	Backup parameter handling	Information for standardized loading and saving of backup entries	UINT8	RO	0x01 (1 _{dec})
10F0:01	Checksum	Checksum across all backup entries of the EtherCAT slave	UINT32	RO	0x00000000 (0 _{dec})

Index 1600 RMB RxPDO-Map Control

Index (hex)	Name	Meaning	Data type	Flags	Default
1600:0	RMB RxPDO-Map Control	PDO Mapping RxPDO-Map control	UINT8	RO	0x07 (7 _{dec})
1600:01	Subindex 001	1. PDO Mapping entry (object 0x7000 (RMB outputs), entry 0x01 (Start calibration))	OCTET-STRING[10]	RO	0x7000:01, 1
1600:02	Subindex 002	2. PDO Mapping entry (object 0x7000 (RMB outputs), entry 0x02 (Disable calibration))	OCTET-STRING[10]	RO	0x7000:02, 1
1600:03	Subindex 003	3. PDO Mapping entry (object 0x7000 (RMB outputs), entry 0x03 (Input freeze))	OCTET-STRING[10]	RO	0x7000:03, 1
1600:04	Subindex 004	4. PDO Mapping entry (4 bits align)	OCTET-STRING[10]	RO	0x0000:00, 1
1600:05	Subindex 005	5. PDO Mapping entry (object 0x7000 (RMB outputs), entry 0x05 (Tara))	OCTET-STRING[10]	RO	0x7000:05, 1
1600:06	Subindex 006	6. PDO Mapping entry (3 bits align)	OCTET-STRING[10]	RO	0x0000:00, 3
1600:07	Subindex 007	7. PDO Mapping entry (8 bits align)	OCTET-STRING[10]	RO	0x0000:00, 8

Index 1800 RMB TxPDO-Par Status

Index (hex)	Name	Meaning	Data type	Flags	Default
1800:0	RMB TxPDO-Par Status	PDO Parameter TxPDO 1	UINT8	RO	0x06 (6 _{dec})
1800:06	Exclude TxPDOs	Specifies the TxPDOs (index of TxPDO mapping objects) that must not be transferred together with TxPDO 1	OCTET-STRING[10]	RO	04 1A 05 1A 06 1A 07 1A 00 00

Index 1801 RMB TxPDO-Par Value (INT32)

Index (hex)	Name	Meaning	Data type	Flags	Default
1801:0	RMB TxPDO-Par Value (INT32)	PDO Parameter TxPDO 2	UINT8	RO	0x06 (6 _{dec})
1801:06	Exclude TxPDOs	Specifies the TxPDOs (index of TxPDO mapping objects) that must not be transferred together with TxPDO 2	OCTET-STRING[10]	RO	02 1A 04 1A 05 1A 06 1A 07 1A

Index 1802 RMB TxPDO-Par Value (Real)

Index (hex)	Name	Meaning	Data type	Flags	Default
1802:0	RMB TxPDO-Par Value (Real)	PDO Parameter TxPDO 3	UINT8	RO	0x06 (6 _{dec})
1802:06	Exclude TxPDOs	Specifies the TxPDOs (index of TxPDO mapping objects) that must not be transferred together with TxPDO 3	OCTET-STRING[10]	RO	01 1A 04 1A 05 1A 06 1A 07 1A

Index 1A00 RMB TxPDO-Map Status

Index (hex)	Name	Meaning	Data type	Flags	Default
1A00:0	RMB TxPDO-Map Status	PDO Mapping RxPDO-Map Status	UINT8	RO	0x0A (10 _{dec})
1A00:01	Subindex 001	1. PDO Mapping entry (1 bits align)	OCTET-STRING[10]	RO	0x0000:00, 1
1A00:02	Subindex 002	2. PDO Mapping entry (object 0x6000 (RMB inputs), entry 0x02 (Overrange))	OCTET-STRING[10]	RO	0x6000:02, 1
1A00:03	Subindex 003	3. PDO Mapping entry (1 bits align)	OCTET-STRING[10]	RO	0x0000:00, 1
1A00:04	Subindex 004	4. PDO Mapping entry (object 0x6000 (RMB inputs), entry 0x04 (Data invalid))	OCTET-STRING[10]	RO	0x6000:04, 1
1A00:05	Subindex 005	5. PDO Mapping entry (2 bits align)	OCTET-STRING[10]	RO	0x0000:00, 2
1A00:06	Subindex 006	6. PDO Mapping entry (object 0x6000 (RMB inputs), entry 0x07 (Error))	OCTET-STRING[10]	RO	0x6000:07, 1
1A00:07	Subindex 007	7. PDO Mapping entry (object 0x6000 (RMB inputs), entry 0x08 (Calibration in progress))	OCTET-STRING[10]	RO	0x6000:08, 1
1A00:08	Subindex 008	8. PDO Mapping entry (object 0x6000 (RMB inputs), entry 0x09 (Steady state))	OCTET-STRING[10]	RO	0x6000:09, 1
1A00:09	Subindex 009	9. PDO Mapping entry (4 bits align)	OCTET-STRING[10]	RO	0x0000:00, 6
1A00:0A	Subindex 010	10. PDO Mapping entry (object 0x6000 (RMB inputs), entry 0x0E (Sync error))	OCTET-STRING[10]	RO	0x6000:10, 1

Index 1A01 RMB TxPDO-Map Value (INT32)

Index (hex)	Name	Meaning	Data type	Flags	Default
1A01:0	RMB TxPDO-Map Value (INT32)	PDO Mapping Value (INT32)	UINT8	RW	0x01 (1 _{dec})
1A01:01	SubIndex 001	1. PDO Mapping entry (object 0x6000 (RMB inputs), entry 0x11 (Value))	UINT32	RW	0x6000:11, 32

Index 1A02 RMB TxPDO-Map Value (Real)

Index (hex)	Name	Meaning	Data type	Flags	Default
1A02:0	RMB TxPDO-Map Value (real)	PDO Mapping Value (real)	UINT8	RW	0x01 (1 _{dec})
1A02:01	SubIndex 001	1. PDO Mapping entry (object 0x6000 (RMB inputs), entry 0x12 (Value (real)))	UINT32	RW	0x6000:12, 32

Index 1C00 Sync manager type

Index (hex)	Name	Meaning	Data type	Flags	Default
1C00:0	Sync manager type	Using the sync managers	UINT8	RO	0x04 (4 _{dec})
1C00:01	SubIndex 001	Sync-Manager Type Channel 1: Mailbox Write	UINT8	RO	0x01 (1 _{dec})
1C00:02	SubIndex 002	Sync-Manager Type Channel 2: Mailbox Read	UINT8	RO	0x02 (2 _{dec})
1C00:03	SubIndex 003	Sync-Manager Type Channel 3: Process Data Write (Outputs)	UINT8	RO	0x03 (3 _{dec})
1C00:04	SubIndex 004	Sync-Manager Type Channel 4: Process Data Read (Inputs)	UINT8	RO	0x04 (4 _{dec})

Index 1C12 RxPDO assign

Index (hex)	Name	Meaning	Data type	Flags	Default
1C12:0	RxPDO assign	PDO Assign Outputs	UINT8	RW	0x02 (2 _{dec})
1C12:01	Subindex 001	1. allocated RxPDO (contains the index of the associated RxPDO mapping object)	UINT16	RW	0x1600 (5632 _{dec})
1C12:02	Subindex 002	2. allocated RxPDO (contains the index of the associated RxPDO mapping object)	UINT16	RW	-

Index 1C13 TxPDO assign

Index (hex)	Name	Meaning	Data type	Flags	Default
1C13:0	TxPDO assign	PDO Assign Inputs	UINT8	RW	0x03 (3 _{dec})
1C13:01	Subindex 001	1. allocated TxPDO (contains the index of the associated TxPDO mapping object)	UINT16	RW	0x1A00 (6656 _{dec})
1C13:02	Subindex 002	2. allocated TxPDO (contains the index of the associated TxPDO mapping object)	UINT16	RW	0x1A01 (6657 _{dec})
1C13:03	Subindex 003	3. allocated TxPDO (contains the index of the associated TxPDO mapping object)	UINT16	RW	-

Index 1C32 SM output parameter

Index (hex)	Name	Meaning	Data type	Flags	Default
1C32:0	SM output parameter	Synchronization parameters for the outputs	UINT8	RO	0x20 (32 _{dec})
1C32:01	Sync mode	Current synchronization mode: <ul style="list-style-type: none"> 0: Free Run 1: Synchron with SM 2 Event 2: DC-Mode - Synchron with SYNC0 Event 3: DC-Mode - Synchron with SYNC1 Event 	UINT16	RW	0x0000 (0 _{dec})
1C32:02	Cycle time	Cycle time (in ns): <ul style="list-style-type: none"> Free Run: Cycle time of the local timer Synchronous with SM 2 event: Master cycle time DC mode: SYNC0/SYNC1 Cycle Time 	UINT32	RW	0x001E8480 (2000000 _{dec})
1C32:03	Shift time	Time between SYNC0 event and output of the outputs (in ns, DC mode only)	UINT32	RO	0x00000000 (0 _{dec})
1C32:04	Sync modes supported	Supported synchronization modes: <ul style="list-style-type: none"> Bit 0 = 1: free run is supported Bit 1 = 1: Synchronous with SM 2 event is supported Bit 2-3 = 01: DC mode is supported Bit 4-5 = 10: Output shift with SYNC1 event (only DC mode) Bit 14 = 1: dynamic times (measurement through writing of 0x1C32:08) 	UINT16	RO	0x0001 (1 _{dec})
1C32:05	Minimum cycle time	Minimum cycle time (in ns)	UINT32	RO	0x000186A0 (100000 _{dec})
1C32:06	Calc and copy time	Minimum time between SYNC0 and SYNC1 event (in ns, DC mode only)	UINT32	RO	0x00000000 (0 _{dec})
1C32:07	Minimum delay time		UINT32	RO	0x00000000 (0 _{dec})
1C32:08	Command	<ul style="list-style-type: none"> 0: Measurement of the local cycle time is stopped 1: Measurement of the local cycle time is started <p>The entries 0x1C32:03, 0x1C32:05, 0x1C32:06, 0x1C32:09, 0x1C33:03, 0x1C33:06, 0x1C33:09 [▶ 76] are updated with the maximum measured values. For a subsequent measurement the measured values are reset</p>	UINT16	RW	0x0000 (0 _{dec})
1C32:09	Maximum Delay time	Time between SYNC1 event and output of the outputs (in ns, DC mode only)	UINT32	RO	0x00000000 (0 _{dec})
1C32:0B	SM event missed counter	Number of missed SM events in OPERATIONAL (DC mode only)	UINT16	RO	0x0000 (0 _{dec})
1C32:0C	Cycle exceeded counter	Number of occasions the cycle time was exceeded in OPERATIONAL (cycle was not completed in time or the next cycle began too early)	UINT16	RO	0x0000 (0 _{dec})
1C32:0D	Shift too short counter	Number of occasions that the interval between SYNC0 and SYNC1 event was too short (DC mode only)	UINT16	RO	0x0000 (0 _{dec})
1C32:20	Sync error	The synchronization was not correct in the last cycle (outputs were output too late; DC mode only)	BOOLEAN	RO	0x00 (0 _{dec})

Index 1C33 SM input parameter

Index	Name	Meaning	Data type	Flags	Default
1C33:0	SM input parameter	Synchronization parameters for the inputs	UINT8	RO	0x20 (32 _{dec})
1C33:01	Sync mode	Current synchronization mode: <ul style="list-style-type: none"> • 0: Free Run • 1: Synchronous with SM 3 event (no outputs available) • 2: DC - Synchronous with SYNC0 Event • 3: DC - Synchronous with SYNC1 Event • 34: Synchronous with SM 2 event (outputs available) 	UINT16	RW	0x0000 (0 _{dec})
1C33:02	Cycle time	as 0x1C32:02	UINT32	RW	0x001E8480 (2000000 _{dec})
1C33:03	Shift time	Time between SYNC0 event and reading of the inputs (in ns, only DC mode)	UINT32	RO	0x00000000 (0 _{dec})
1C33:04	Sync modes supported	Supported synchronization modes: <ul style="list-style-type: none"> • Bit 0: free run is supported • Bit 1: synchronous with SM 2 event is supported (outputs available) • Bit 1: synchronous with SM 3 event is supported (no outputs available) • Bit 2-3 = 01: DC mode is supported • Bit 4-5 = 01: input shift through local event (outputs available) • Bit 4-5 = 10: input shift with SYNC1 event (no outputs available) • Bit 14 = 1: dynamic times (measurement through writing of 0x1C32:08 or 0x1C33:08) 	UINT16	RO	0x0001 (1 _{dec})
1C33:05	Minimum cycle time	as 0x1C32:05	UINT32	RO	0x000186A0 (100000 _{dec})
1C33:06	Calc and copy time	Time between reading of the inputs and availability of the inputs for the master (in ns, only DC mode)	UINT32	RO	0x00000000 (0 _{dec})
1C33:07	Minimum delay time		UINT32	RO	0x00000000 (0 _{dec})
1C33:08	Command	as 0x1C32:08	UINT16	RW	0x0000 (0 _{dec})
1C33:09	Maximum Delay time	Time between SYNC1 event and reading of the inputs (in ns, only DC mode)	UINT32	RO	0x00000000 (0 _{dec})
1C33:0B	SM event missed counter	as 0x1C32:11	UINT16	RO	0x0000 (0 _{dec})
1C33:0C	Cycle exceeded counter	as 0x1C32:12	UINT16	RO	0x0000 (0 _{dec})
1C33:0D	Shift too short counter	as 0x1C32:13	UINT16	RO	0x0000 (0 _{dec})
1C33:20	Sync error	as 0x1C32:32	BOOLEAN	RO	0x00 (0 _{dec})

Index F000 Modular device profile

Index (hex)	Name	Meaning	Data type	Flags	Default
F000:0	Modular device profile	General information for the modular device profile	UINT8	RO	0x02 (2 _{dec})
F000:01	Module index distance	Index spacing of the objects of the individual channels	UINT16	RO	0x0010 (16 _{dec})
F000:02	Maximum number of modules	Number of channels	UINT16	RO	EL3351-0000: 0x0001 (1 _{dec}) EL3351-0090: 0x0002 (2 _{dec})

Index F008 Code word

Index (hex)	Name	Meaning	Data type	Flags	Default
F008:0	Code word	reserved	UINT32	RW	0x00000000 (0 _{dec})

Index F010 Module list

Index (hex)	Name	Meaning	Data type	Flags	Default
F010:0	Module list	Max. subindex	UINT8	RW	0x02 (2 _{dec})
F010:01	SubIndex 001	RMB	UINT32	RW	0x00000172 (370 _{dec})
F010:02*	SubIndex 002	TSC	UINT32	RW	0x000003B6 (950 _{dec})

*) ELX3351-0090 only

6 Appendix

6.1 EtherCAT AL Status Codes

For detailed information please refer to the [EtherCAT system description](#).

6.2 UL notice

● Application

i The modules are intended for use with Beckhoff's UL Listed EtherCAT System only.

● Examination

i For cULus examination, the Beckhoff I/O System has only been investigated for risk of fire and electrical shock (in accordance with UL508 and CSA C22.2 No. 142).

● For devices with Ethernet connectors

i Not for connection to telecommunication circuits.

Basic principles

Two UL certificates are met in the Beckhoff EtherCAT product range, depending upon the components:

1. UL certification according to UL508. Devices with this kind of certification are marked by this sign:



2. UL certification according to UL508 with limited power consumption. The current consumed by the device is limited to a max. possible current consumption of 4 A. Devices with this kind of certification are marked by this sign:

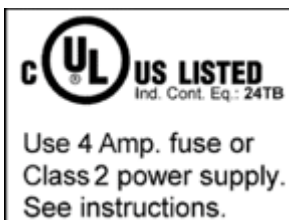

Almost all current EtherCAT products (as at 2010/05) are UL certified without restrictions.

Application

If *restricted* certified devices are used, the current consumption at 24 V_{DC} must be limited accordingly by supplying

- from an isolated source protected by a fuse of max. 4 A (according to UL248) or
- from a voltage supply complying with *NEC class 2*.
An *NEC class 2* voltage source must not be connected in series or parallel with another *NEC class 2* voltage source!

These requirements apply to the supply of all EtherCAT bus couplers, power supply terminals, bus terminals and their power contacts.

6.3 FM notice

Special notice regarding ANSI/ISA Ex

⚠ WARNING

Observe the permissible range of application!

The I/O modules of the ELX series may only be used in potentially explosive areas of Class I, Division 2, Group A, B, C, D or in non-explosive areas!

⚠ WARNING



Consider the *Control Drawing ELX* documentation!

When installing the I/O modules of the ELX series, be sure to read the *Control Drawing ELX* documentation, which is available in the download area of your ELX terminal on <https://www.beckhoff.com/ELXxxxx!>

6.4 Support and Service

Beckhoff and their partners around the world offer comprehensive support and service, making available fast and competent assistance with all questions related to Beckhoff products and system solutions.

Beckhoff's branch offices and representatives

Please contact your Beckhoff branch office or representative for local support and service on Beckhoff products!

The addresses of Beckhoff's branch offices and representatives round the world can be found on her internet pages: www.beckhoff.com

You will also find further documentation for Beckhoff components there.

Support

The Beckhoff Support offers you comprehensive technical assistance, helping you not only with the application of individual Beckhoff products, but also with other, wide-ranging services:

- support
- design, programming and commissioning of complex automation systems
- and extensive training program for Beckhoff system components

Hotline: +49 5246 963 157
e-mail: support@beckhoff.com
web: www.beckhoff.com/support

Service

The Beckhoff Service Center supports you in all matters of after-sales service:

- on-site service
- repair service
- spare parts service
- hotline service

Hotline: +49 5246 963 460
e-mail: service@beckhoff.com
web: www.beckhoff.com/service

Headquarters Germany

Beckhoff Automation GmbH & Co. KG

Hülshorstweg 20
33415 Verl
Germany

Phone: +49 5246 963 0
e-mail: info@beckhoff.com
web: www.beckhoff.com

Table of figures

Fig. 1	ELX1052-0000 with date code 43220001, BTN 999apr7y and Ex marking.....	9
Fig. 2	ELX9560-0000 with date code 37220005, BTN 999arb1p and Ex marking.....	10
Fig. 3	ELX9012 with date code 36230000, BTN 000bh4yr and Ex marking.....	11
Fig. 4	ELX3351 - One channel analog input terminal for strain gauge, Ex i.....	12
Fig. 5	Permissible arrangement of the ELX terminals (right terminal block).....	18
Fig. 6	Permitted arrangement - terminals that do not belong to the ELX series are placed before and after the ELX terminal segment. Isolation is provided by the ELX9560 at the beginning of the ELX terminal segment and two ELX9410 at the end of the ELX terminal segment.....	18
Fig. 7	Permitted arrangement - terminals that do not belong to the ELX series are placed before and after the ELX terminal segment. Isolation is provided by the ELX9560 at the beginning of the ELX terminal segment and the EK1110 at the end of the ELX terminal segment.....	19
Fig. 8	Permitted arrangement - multiple resupplies by ELX9560 with an upstream ELX9410 in each case.....	19
Fig. 9	Permitted arrangement - ELX9410 in front of an ELX9560 power supply terminal.....	19
Fig. 10	Illegal arrangement - missing ELX9560 power supply terminal.....	19
Fig. 11	Impermissible arrangement - terminal in the ELX terminal segment that does not belong to the ELX series.....	20
Fig. 12	Impermissible arrangement - second ELX9560 power supply terminal in the ELX terminal segment without upstream ELX9410.....	20
Fig. 13	Illegal arrangement - missing ELX9012 bus end cap.....	20
Fig. 14	Installation position and minimum distances.....	21
Fig. 15	Attaching on mounting rail.....	22
Fig. 16	Disassembling of terminal.....	23
Fig. 17	Standard wiring.....	24
Fig. 18	High Density Terminals.....	24
Fig. 19	Connecting a cable on a terminal point.....	25
Fig. 20	ELX3351 - Contact assignment and LEDs.....	27
Fig. 21	ELX3351 - Connection of a full bridge in 6-wire technology.....	27
Fig. 22	ELX3351 - Power supply.....	28
Fig. 23	ELX3351 - Measuring range UD as a function of the bridge input resistance.....	28
Fig. 24	Full scale value, measuring span.....	30
Fig. 25	SE and DIFF module as 2-channel version.....	33
Fig. 26	2-wire connection.....	35
Fig. 27	Common-mode voltage (V_{cm}).....	36
Fig. 28	Recommended operating voltage range.....	37
Fig. 29	Signal processing analog input.....	38
Fig. 30	Diagram Signal delay (step response).....	39
Fig. 31	Diagram Signal delay (linear).....	39
Fig. 32	Used names: in the following section (left), in this remaining documentation (right).....	40
Fig. 33	Schematic view of a strain gauge.....	40
Fig. 34	quarter, half, and full bridge.....	41
Fig. 35	4-wire connection.....	43
Fig. 36	6-wire connection.....	43
Fig. 37	Example of a load cell.....	44
Fig. 38	Parallel strain gauge.....	47
Fig. 39	Shunt calibration.....	47

Fig. 40	Measuring bridge with 4 bridge resistors	49
Fig. 41	Measuring bridge with 4 bridge resistors and 2 additional resistors	49
Fig. 42	Example 1 - Comprehensive consideration of the 4-wire connection for an ELM350x.....	50
Fig. 43	Example 2 - Comprehensive consideration of the 6-wire connection for an ELM350x.....	50
Fig. 44	Natural frequency as a function of mass.....	52
Fig. 45	Max. input voltages	54
Fig. 46	Parallel connection with ELX3351.....	55
Fig. 47	ELX3351 - Block diagramm	56
Fig. 48	Notch characteristic/amplitude curve and step response of the FIR filter	56
Fig. 49	Step response of the IIR filter.....	57
Fig. 50	Effect of dynamic IIR filters	58
Fig. 51	InputFreeze example	60
Fig. 52	Idling recognition example	61
Fig. 53	Adaptation to the sensor curve	62
Fig. 54	Zero calibration with command 0x0101 in CoE object 0xFB00:01.....	63
Fig. 55	Loading with reference load, command 0x0102 in CoE object 0xFB00:01.....	63
Fig. 56	Control word, tare.....	65
Fig. 57	ELX3351 - process data selection in the TwinCAT System Manager.....	66
Fig. 58	ELX3351 - selection Predefined PDO Assignment	67
Fig. 59	ELX3351 - Default process image	67
Fig. 60	Load value in floating-point representation	69

More Information:

www.beckhoff.com/ELX3351

Beckhoff Automation GmbH & Co. KG
Hülshorstweg 20
33415 Verl
Germany
Phone: +49 5246 9630
info@beckhoff.com
www.beckhoff.com

