

Documentation | EN

# EPP622x

IO-Link Master with protection class IP67





# Table of contents

<b>1 Foreword</b> .....	<b>7</b>
1.1 Notes on the documentation .....	7
1.2 Safety instructions .....	8
1.3 Documentation issue status .....	9
<b>2 Product group: EtherCAT P Box modules</b> .....	<b>10</b>
<b>3 Product overview</b> .....	<b>11</b>
3.1 EPP6224-0002 .....	12
3.1.1 Technical data .....	13
3.1.2 Scope of supply.....	14
3.1.3 Process image .....	15
3.2 EPP6224-0522 .....	16
3.2.1 Technical data .....	17
3.2.2 Scope of supply.....	19
3.2.3 Process image .....	20
3.3 EPP6228-0022 .....	21
3.3.1 Technical data .....	22
3.3.2 Scope of supply.....	23
3.3.3 Process image .....	24
<b>4 Basic function principles</b> .....	<b>25</b>
4.1 IO-Link basics .....	25
4.1.1 IO-Link system layout.....	25
4.1.2 Establishment of IO Link communication .....	26
4.1.3 Device description IODD .....	27
4.1.4 Parameter server .....	27
4.1.5 Data transfer rate .....	27
4.2 Timestamp inputs (EPP6224-0522) .....	28
<b>5 Mounting</b> .....	<b>29</b>
5.1 EPP6224-0002 .....	29
5.1.1 Dimensions .....	29
5.1.2 Mounting .....	30
5.1.3 Functional earth .....	30
5.2 EPP6224-0522 .....	31
5.2.1 Dimensions .....	31
5.2.2 Mounting .....	32
5.2.3 Functional earth .....	32
5.3 EPP6228-0022 .....	33
5.3.1 Dimensions .....	33
5.3.2 Mounting .....	34
5.3.3 Functional earth .....	34
<b>6 Connection</b> .....	<b>35</b>
6.1 Tightening torques for plug connectors .....	35
6.2 EtherCAT P .....	36
6.2.1 Connectors.....	37

6.2.2	Status LEDs .....	38
6.2.3	Conductor losses .....	39
6.3	IO-Link ports.....	40
6.3.1	EPP6224-0002.....	40
6.3.2	EPP6224-0522.....	42
6.3.3	EPP6228-0022.....	44
6.4	Digital-combi-channels (EPP6224-0522 only) .....	46
6.4.1	Status LEDs .....	47
6.5	UL Requirements .....	48
<b>7</b>	<b>Commissioning and configuration .....</b>	<b>49</b>
7.1	Integrating into a TwinCAT project.....	49
7.2	Timestamp inputs (EPP6224-0522 only) .....	50
7.2.1	Configuring process data .....	50
7.2.2	Configuration for multiple edges per PLC cycle .....	52
7.3	Configuration of the IO link master.....	53
7.4	Configuration of the IO-Link devices .....	54
7.4.1	Open the IO link configuration tool.....	54
7.4.2	Integrating IO-Link devices .....	55
7.4.3	Removal of IO-Link devices .....	64
7.4.4	Activating the configuration .....	65
7.5	Settings of the IO-Link devices .....	66
7.6	EPIxxxx, ERIxxxx - Setting of the IO-Link device parameters .....	68
7.7	Access to IO-Link data .....	79
7.7.1	IO-Link system communication .....	79
7.7.2	PDO Assignment.....	80
7.7.3	Accessing IO-Link parameters .....	81
7.7.4	Parameter data exchange.....	82
7.7.5	ADS.....	83
7.7.6	Access to events .....	84
7.7.7	PLC library: Tc3_IoLink.....	85
7.8	Restore the delivery state .....	86
7.9	Decommissioning.....	87
<b>8</b>	<b>Diagnosis .....</b>	<b>88</b>
8.1	Status of the IO-Link ports .....	88
8.1.1	Interpretation of the status bytes.....	88
8.2	ADS Error Codes .....	90
8.3	Further error diagnosis.....	93
<b>9</b>	<b>CoE objects .....</b>	<b>94</b>
9.1	EPP6224-0002.....	94
9.1.1	Configuration objects .....	95
9.1.2	Information objects.....	97
9.1.3	Standard objects .....	100
9.2	EPP6224-0522.....	107
9.2.1	Configuration objects .....	108
9.2.2	Information objects.....	110

9.2.3	Standard objects .....	113
9.3	EPP6228-0022 .....	120
9.3.1	Configuration objects .....	122
9.3.2	Information objects .....	124
9.3.3	Standard objects .....	127
<b>10</b>	<b>Appendix .....</b>	<b>134</b>
10.1	General operating conditions .....	134
10.2	Accessories .....	135
10.3	Version identification of EtherCAT devices .....	136
10.3.1	General notes on marking .....	136
10.3.2	Version identification of IP67 modules .....	137
10.3.3	Beckhoff Identification Code (BIC) .....	138
10.3.4	Electronic access to the BIC (eBIC) .....	140
10.4	Support and Service .....	142



# 1 Foreword

## 1.1 Notes on the documentation

### Intended audience

This description is only intended for the use of trained specialists in control and automation engineering who are familiar with the applicable national standards.

It is essential that the documentation and the following notes and explanations are followed when installing and commissioning these components.

The qualified personnel is obliged to always use the currently valid documentation.

The responsible staff must ensure that the application or use of the products described satisfy all the requirements for safety, including all the relevant laws, regulations, guidelines and standards.

### Disclaimer

The documentation has been prepared with care. The products described are, however, constantly under development.

We reserve the right to revise and change the documentation at any time and without prior announcement.

No claims for the modification of products that have already been supplied may be made on the basis of the data, diagrams and descriptions in this documentation.

### Trademarks

Beckhoff®, ATRO®, EtherCAT®, EtherCAT G®, EtherCAT G10®, EtherCAT P®, MX-System®, Safety over EtherCAT®, TC/BSD®, TwinCAT®, TwinCAT/BSD®, TwinSAFE®, XFC®, XPlanar® and XTS® are registered trademarks of and licensed by Beckhoff Automation GmbH.

Other designations used in this publication may be trademarks whose use by third parties for their own purposes could violate the rights of the owners.



EtherCAT® is registered trademark and patented technology, licensed by Beckhoff Automation GmbH, Germany.

### Copyright

© Beckhoff Automation GmbH & Co. KG, Germany.

The reproduction, distribution and utilization of this document as well as the communication of its contents to others without express authorization are prohibited.

Offenders will be held liable for the payment of damages. All rights reserved in the event of the grant of a patent, utility model or design.

### Third-party brands

Trademarks of third parties may be used in this documentation. You can find the trademark notices here:

<https://www.beckhoff.com/trademarks>

## 1.2 Safety instructions

### Safety regulations

Please note the following safety instructions and explanations!  
Product-specific safety instructions can be found on following pages or in the areas mounting, wiring, commissioning etc.

### Exclusion of liability

All the components are supplied in particular hardware and software configurations appropriate for the application. Modifications to hardware or software configurations other than those described in the documentation are not permitted, and nullify the liability of Beckhoff Automation GmbH & Co. KG.

### Personnel qualification

This description is only intended for trained specialists in control, automation and drive engineering who are familiar with the applicable national standards.

### Signal words

The signal words used in the documentation are classified below. In order to prevent injury and damage to persons and property, read and follow the safety and warning notices.

### Personal injury warnings

**⚠ DANGER**

Hazard with high risk of death or serious injury.

**⚠ WARNING**

Hazard with medium risk of death or serious injury.

**⚠ CAUTION**

There is a low-risk hazard that could result in medium or minor injury.

### Warning of damage to property or environment

**NOTICE**

The environment, equipment, or data may be damaged.

### Information on handling the product



This information includes, for example:  
recommendations for action, assistance or further information on the product.

## 1.3 Documentation issue status

Version	Comment
1.0	• First release

### Firmware and hardware versions

This documentation refers to the firmware and hardware version that was applicable at the time the documentation was written.

The module features are continuously improved and developed further. Modules having earlier production statuses cannot have the same properties as modules with the latest status. However, existing properties are retained and are not changed, so that older modules can always be replaced with new ones.

The firmware and hardware version (delivery state) can be found in the batch number (D-number) printed on the side of the EtherCAT Box.

### Syntax of the batch number (D-number)

D: WW YY FF HH

WW - week of production (calendar week)

YY - year of production

FF - firmware version

HH - hardware version

Example with D no. 29 10 02 01:

29 - week of production 29

10 - year of production 2010

02 - firmware version 02

01 - hardware version 01

Further information on this topic: [Version identification of EtherCAT devices](#) [► 136].

## 2 Product group: EtherCAT P Box modules

### EtherCAT P

EtherCAT P supplements the EtherCAT technology with a process in which communication and supply voltages are transmitted on a common line. All EtherCAT properties are retained with this process.

Two supply voltages are transmitted per EtherCAT P line. The supply voltages are electrically isolated from each other and can therefore be switched individually. The nominal supply voltage for both is  $24\text{ V}_{\text{DC}}$ .

EtherCAT P uses the same cable structure as EtherCAT: a 4-core Ethernet cable with M8 connectors. The connectors are mechanically coded so that EtherCAT connectors and EtherCAT P connectors cannot be interchanged.

### EtherCAT P Box modules

EtherCAT P Box modules are EtherCAT P slaves with degree of protection IP67. They are designed for operation in wet, dirty or dusty industrial environments.

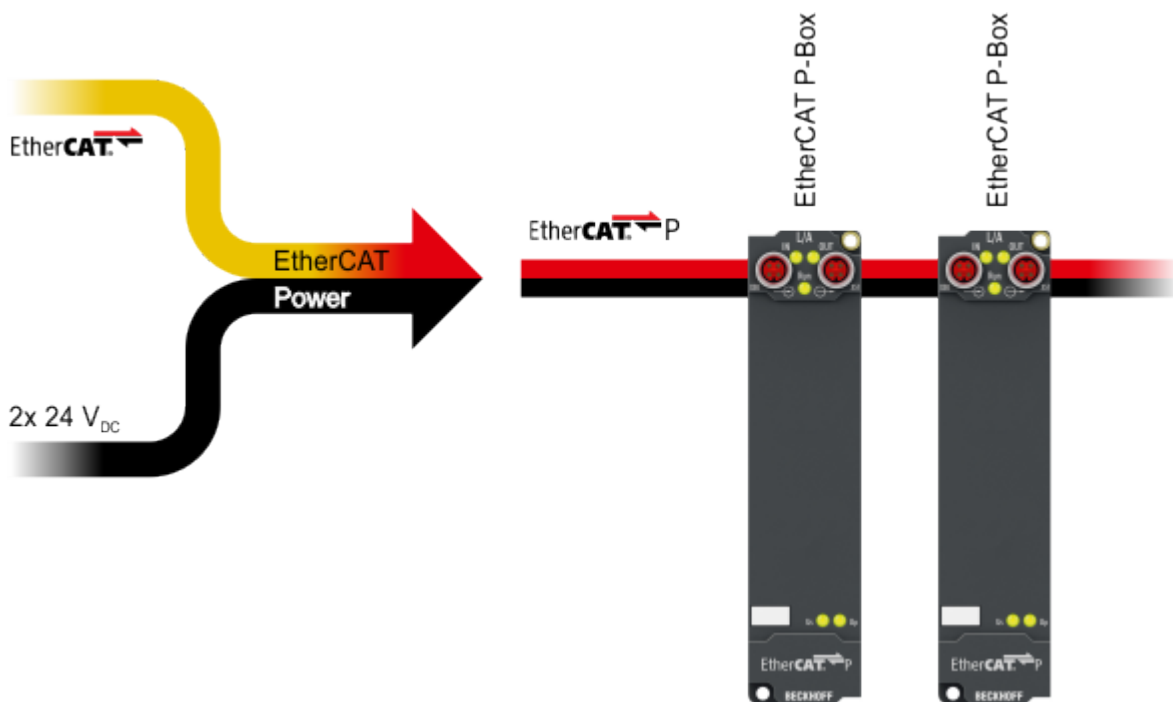

### **i** EtherCAT basics

A detailed description of the EtherCAT system can be found in the [EtherCAT system documentation](#).

### 3 Product overview

The following table shows the products described in this documentation and the main distinguishing features.

Product	Number of IO-Link Ports Class A	Additional I/O
<a href="#">EPP6224-0002</a> [ <a href="#">▶ 12</a> ]	4	4 digital inputs
<a href="#">EPP6224-0522</a> [ <a href="#">▶ 16</a> ]	4	4 Digital inputs with timestamp 8 digital combi channels
<a href="#">EPP6228-0022</a> [ <a href="#">▶ 21</a> ]	8	8 digital inputs

### 3.1 EPP6224-0002

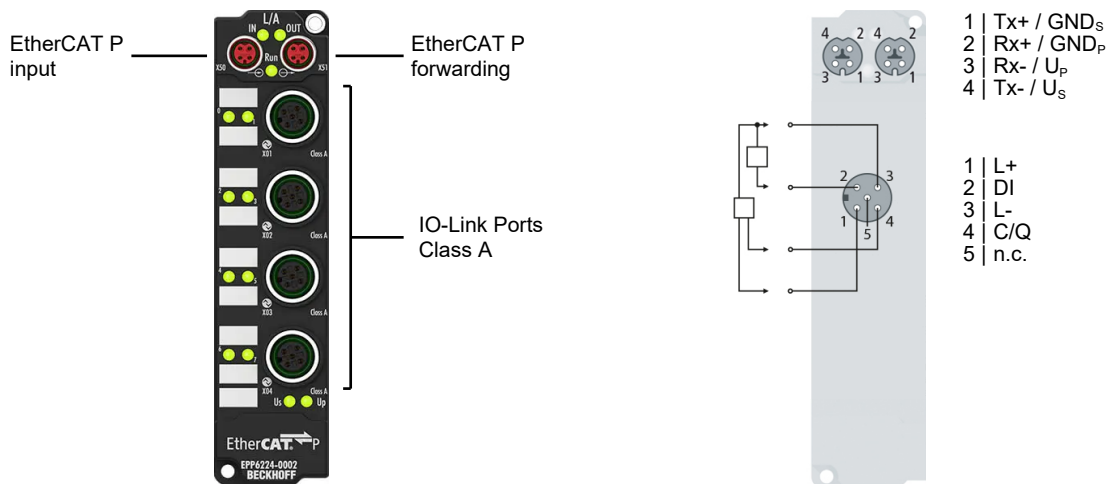

The EPP6224-0002 IO-Link master module enables the connection of up to four IO-Link devices. These can be IO-Link box modules, actuators, sensors or combinations of both. The EPP6224-0002 also offers an additional digital input on each of the four Class A master ports.

The EtherCAT Box is parameterized via the EtherCAT master. The parameterization of the IO-Link devices with service data can take place from TwinCAT via ADS or, very conveniently, via the integrated IO-Link configuration tool.

In the default setting, the four C/Q channels of the EPP6224-0002 operate as IO-Link channels. Each IO-Link channel can also optionally be used just as an input or output channel.

#### Quick links

[Technical data \[► 13\]](#)

[Process image \[► 15\]](#)

[Dimensions \[► 29\]](#)

[IO-Link-connection \[► 40\]](#)

### 3.1.1 Technical data

All values are typical values over the entire temperature range, unless stated otherwise.

EtherCAT P	
Connection	2 x M8 socket, 4-pin, P-coded, shielded
Distributed Clocks	yes

Supply voltages	
Connection	See EtherCAT P connection
$U_S$ nominal voltage	24 V <sub>DC</sub> (-15 % / +20 %)
$U_S$ sum current: $I_{S,sum}$	max. 3 A
Current consumption from $U_S$	100 mA + load
Rated voltage $U_P$	24 V <sub>DC</sub> (-15 % / +20 %)
$U_P$ sum current: $I_{P,sum}$	max. 3 A
Current consumption from $U_P$	None. $U_P$ is only forwarded.

IO-Link	
Number of ports Class A	4
Connection	4 x M12 socket, 5-pin, A-coded
Cable length	max. 20 m
Specification	IO-Link V1.1
Data rates	COM1: 4.8 kbit/s COM2: 38.4 kbit/s COM3: 230.4 kbit/s
Sensor power supply L+	24 V <sub>DC</sub> from $U_S$
L+ output current	max. 1.4 A per port, short-circuit proof max. 3.0 A in total
Extra power P24	-
C/Q input filter	none (when configured as digital input, see <a href="#">2. Assigning IO-Link device to port n [► 58]</a> )
C/Q output current	max. 200 mA, not short-circuit proof (when configured as digital output, see <a href="#">2. Assigning IO-Link device to port n [► 58]</a> )

Digital inputs	
Number	4
Connection	On pin 2 of the IO-Link ports
Characteristics	Type 3 according to EN 61131-2, compatible with type 1
Input filter	10 µs
Signal voltage "0"	-3 ... +5 V
Signal voltage "1"	+11 ... +30 V
Input current	3 mA

Housing data	
Dimensions W × H × D	30 mm × 126 mm × 26.5 mm (without connectors)
Weight	approx. 165 g
Installation position	variable
Material	PA6 (polyamide)

Environmental conditions	
Ambient temperature during operation	-25 ... +60 °C
Ambient temperature during storage	-40 ... +85 °C
Vibration / shock resistance	conforms to EN 60068-2-6 / EN 60068-2-27
EMC immunity / emission	conforms to EN 61000-6-2 / EN 61000-6-4
Protection class	IP65, IP66, IP67 conforms to EN 60529

Approvals / markings	
Approvals / markings *)	CE, UL under preparation

\*) Real applicable approvals/markings see type plate on the side (product marking).

### Additional tests

The devices have undergone the following additional tests:

Test	Explanation
Vibration	10 frequency sweeps in 3 axes
	5 Hz < f < 60 Hz displacement 0.35 mm, constant amplitude
	60.1 Hz < f < 500 Hz acceleration 5 g, constant amplitude
Shocks	1000 shocks in each direction, in 3 axes
	35 g, 11 ms

## 3.1.2 Scope of supply

Make sure that the following components are included in the scope of delivery:

- 1x EPP6224-0002
- 2x protective cap for EtherCAT P socket, M8, red (pre-assembled)
- 20 x labels, blank (2 strips of 10)









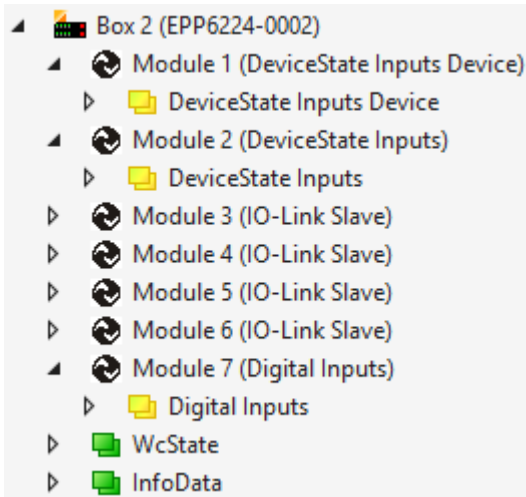

### Pre-assembled protective caps do not ensure IP67 protection

Protective caps are pre-assembled at the factory to protect connectors during transport. They may not be tight enough to ensure IP67 protection.

Ensure that the protective caps are correctly seated to ensure IP67 protection.

### 3.1.3 Process image



-  Module 1  
 Diagnostics.  
 See chapter [Further error diagnosis \[► 93\]](#).
-  Module 2  
 Status variables of the IO-Link ports.  
 See chapter [Status of the IO-Link ports \[► 88\]](#).
-  Module 3 <sup>1)</sup>  
 Process data of the IO-Link device at port X01
-  Module 4 <sup>1)</sup>  
 Process data of the IO-Link device at port X02
-  Module 5 <sup>1)</sup>  
 Process data of the IO-Link device at port X03
-  Module 6 <sup>1)</sup>  
 Process data of the IO-Link device at port X04
-  Module 7  
 Digital inputs.

<sup>1)</sup> The modules "Module 3" to "Module 6" only exist in the process data if the corresponding IO-Link ports have been configured.

### 3.2 EPP6224-0522

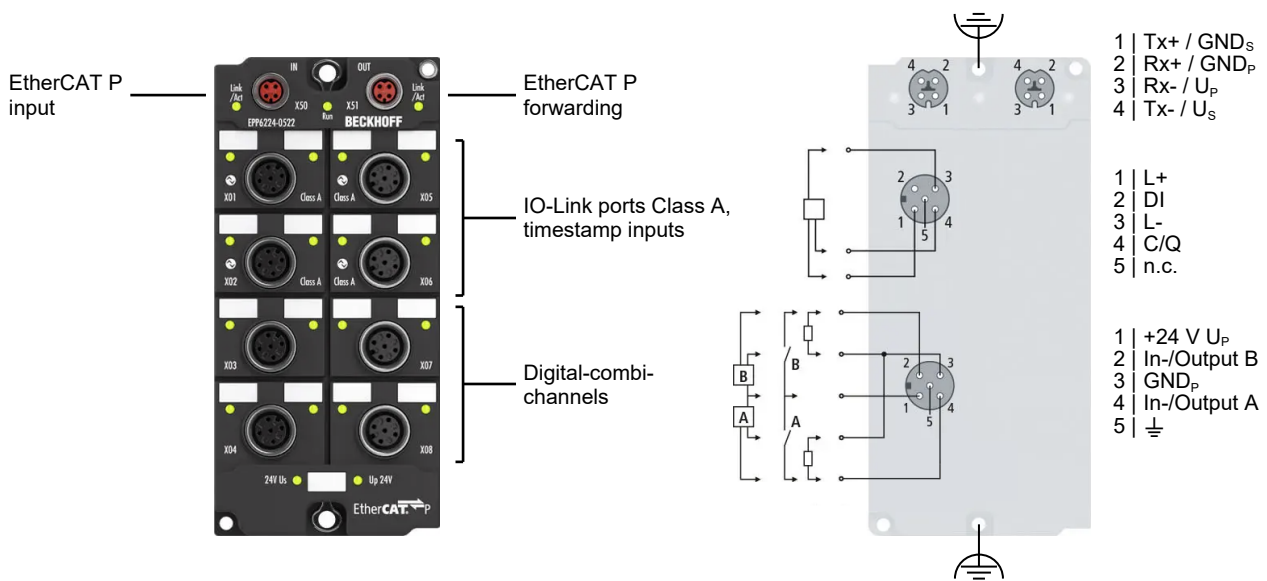

The EP6224-0522 IO-Link module enables the connection of up to four IO-Link devices. These can be actuators, sensors, or a combination of both. On the M12 sockets with the Class A ports, a digital input with timestamp is additionally available, which indicates the time of the last edge change with a resolution of 1 ns.

This technology enables signal curves to be traced exactly over time and correlated with the Distributed Clocks throughout the system. What's more, machine-wide parallel hardware wiring of digital inputs or encoder signals for synchronization purposes is often no longer required with this technology. As a result, responses with equidistant time intervals, independent of the bus cycle time, are to a large extent possible. The other four M12 ports have 8 digital combi channels, each of which can be used as an input or output. The EtherCAT Box is parameterized via the EtherCAT master. The service data of the IO-Link devices can be transferred directly from TwinCAT via ADS or very conveniently via the integrated IO-Link configuration tool.

In the default setting, the IO-Link channels operate as standard 4-channel inputs 24 V<sub>DC</sub>, which communicate with connected IO-Link devices as required, parameterize them, and change the operation mode if necessary. Each IO-Link channel can also optionally be used just as an input or output channel. The integration of IO-Link and timestamp makes the box module ideal for applications such as the detection of print marks or other time-critical processes.

#### Special features

- IO-Link V1.1
- convenient sensor parameterization in TwinCAT
- additional timestamp input on the M12 port

#### Quick links

- [Technical data \[▶ 17\]](#)
- [Process image \[▶ 20\]](#)
- [Dimensions \[▶ 31\]](#)
- [IO-Link-connection \[▶ 42\]](#)

### 3.2.1 Technical data

All values are typical values over the entire temperature range, unless stated otherwise.

<b>EtherCAT P</b>	
Connection	2 x M8 socket, 4-pin, P-coded, shielded
Distributed Clocks	yes

<b>Supply voltages</b>	
Connection	See EtherCAT P connection
$U_s$ nominal voltage	24 V <sub>DC</sub> (-15 % / +20 %)
$U_s$ sum current: $I_{s,sum}$	max. 3 A
Current consumption from $U_s$	130 mA + load (IO-Link-Ports)
Rated voltage $U_p$	24 V <sub>DC</sub> (-15 % / +20 %)
$U_p$ sum current: $I_{p,sum}$	max. 3 A
Current consumption from $U_p$	20 mA + Output currents of the digital combi channels incl. sensor power supply

<b>IO-Link</b>	
Number of ports Class A	4
Connection	4 x M12 socket, 5-pin, A-coded
Cable length	max. 20 m
Specification	IO-Link V1.1
Data rates	COM1: 4.8 kbit/s COM2: 38.4 kbit/s COM3: 230.4 kbit/s
Sensor power supply L+	24 V <sub>DC</sub> from $U_s$
L+ output current	max. 1.4 A per port, short-circuit proof max. 3.0 A in total
Extra power P24	-
C/Q input filter	none (when configured as digital input, see <a href="#">2. Assigning IO-Link device to port n [► 58]</a> )
C/Q output current	max. 200 mA, not short-circuit proof (when configured as digital output, see <a href="#">2. Assigning IO-Link device to port n [► 58]</a> )

<b>Digital inputs with Timestamp</b>	
Number	4
Connection	On pin 2 of the IO-Link ports
Characteristics	similar to type 3 according to EN 61131-2
Input filter	none
Signal voltage "0"	-3 ... +5 V
Signal voltage "1"	+11 ... +30 V
Input current	3 mA
Timestamp resolution	1 ns
Timestamp accuracy	10 ns + input delay (Accuracy of Distributed Clocks: < 100 ns)

Digital combi channels	
Number	8
Connection	4 x M12 socket, 5-pin, A-coded
Cable length	max. 30 m
Digital output voltage	24 V <sub>DC</sub> from U <sub>P</sub> max. 0.5 A per channel, short-circuit proof max. 3 A in total
Output switching times	T <sub>ON</sub> : 140 µs T <sub>OFF</sub> : 300 µs
Rated input voltage	24 V <sub>DC</sub>
Input current	3 mA
Input filter time	10 µs
Input characteristics	Type 3 according to EN 61131-2, compatible with type 1
Input signal voltage "0"	-3 ... +5 V
Input signal voltage "1"	11 ... 30 V
Sensor power supply / auxiliary voltage	24 V <sub>DC</sub> from U <sub>P</sub> , max. 0.5 A in total, short-circuit proof.

Housing data	
Dimensions W × H × D	60 mm × 126 mm × 26.5 mm (without plug connectors)
Weight	approx. 250 g
Installation position	variable
Material	PA6 (polyamide)

Environmental conditions	
Ambient temperature during operation	-25 ... +60 °C
Ambient temperature during storage	-40 ... +85 °C
Vibration / shock resistance	conforms to EN 60068-2-6 / EN 60068-2-27
EMC immunity / emission	conforms to EN 61000-6-2 / EN 61000-6-4
Protection class	IP65, IP66, IP67 conforms to EN 60529

Approvals / markings	
Approvals / markings *)	CE, UL under preparation

\*) Real applicable approvals/markings see type plate on the side (product marking).

### Additional tests

The devices have undergone the following additional tests:

Test	Explanation
Vibration	10 frequency sweeps in 3 axes
	5 Hz < f < 60 Hz displacement 0.35 mm, constant amplitude
	60.1 Hz < f < 500 Hz acceleration 5 g, constant amplitude
Shocks	1000 shocks in each direction, in 3 axes
	35 g, 11 ms

### 3.2.2 Scope of supply

Make sure that the following components are included in the scope of delivery:

- 1x EPP6224-0522
- 2x protective cap for EtherCAT P socket, M8, red (pre-assembled)
- 20 x labels, blank (2 strips of 10)

---

**i** **Pre-assembled protective caps do not ensure IP67 protection**

Protective caps are pre-assembled at the factory to protect connectors during transport. They may not be tight enough to ensure IP67 protection.

Ensure that the protective caps are correctly seated to ensure IP67 protection.

---

### 3.2.3 Process image

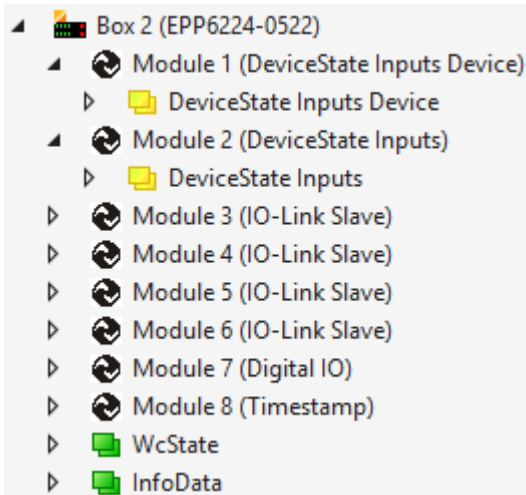

- Module 1  
Diagnostics.  
See chapter [Further error diagnosis](#) [▶ 93].
- Module 2  
Status variables of the IO-Link ports.  
See chapter [Status of the IO-Link ports](#) [▶ 88].
- Module 3 <sup>1)</sup>  
Process data of the IO-Link device at port X01
- Module 4 <sup>1)</sup>  
Process data of the IO-Link device at port X02
- Module 5 <sup>1)</sup>  
Process data of the IO-Link device at port X03
- Module 6 <sup>1)</sup>  
Process data of the IO-Link device at port X04
- Module 7  
Digital I/O
- Module 8  
Timestamp inputs

<sup>1)</sup> The modules "Module 3" to "Module 6" only exist in the process data if the corresponding IO-Link ports have been configured.

#### Module 8 (Timestamp)

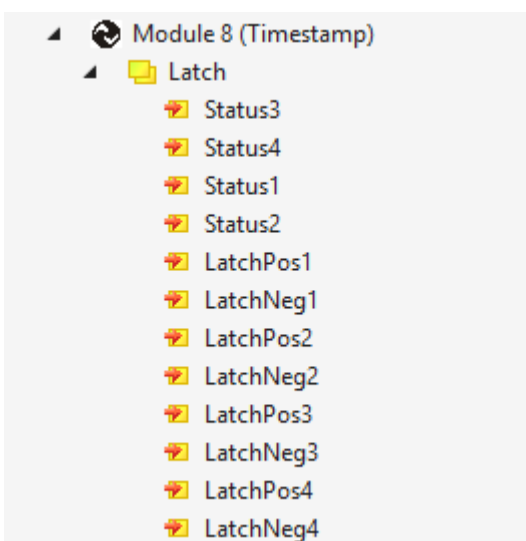

#### Status0 ... Status4

Bit 2 contains the current signal level. Bits 0 and 1 can signal the occurrence of signal edges depending on the configuration, see chapter [Configuration for multiple edges per PLC cycle](#) [▶ 52].

#### LatchPos0 ... LatchPos4

Timestamp of the last recorded rising signal edge. Representation: 1 ns/LSB

#### LatchNeg0 ... LatchNeg4

Timestamp of the last recorded falling signal edge. Representation: 1 ns/LSB

### 3.3 EPP6228-0022

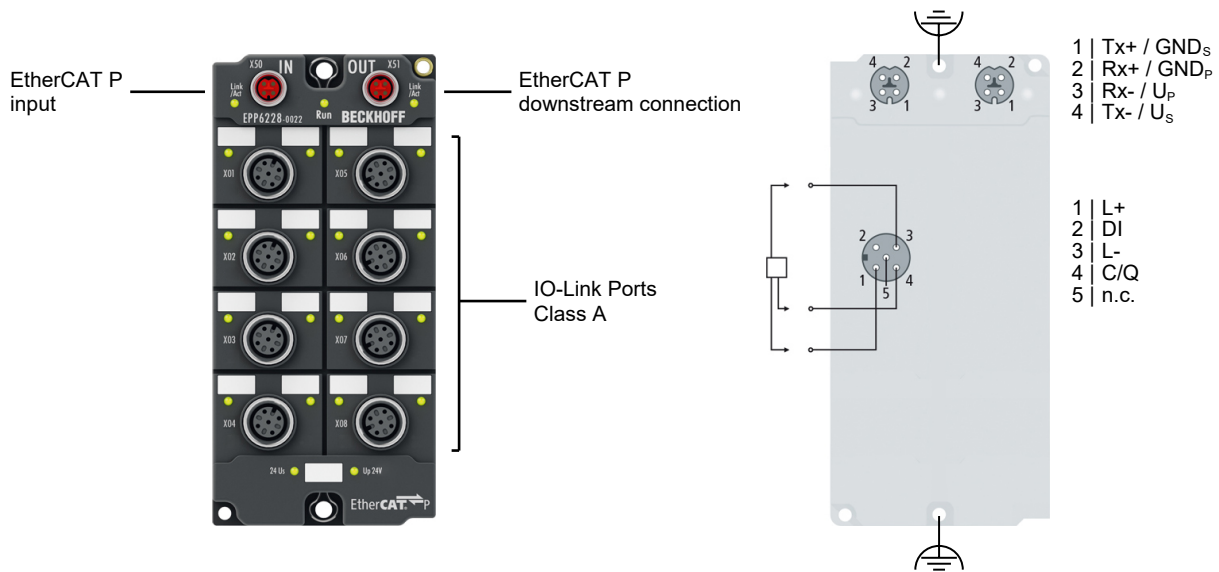

The EPP6228-0022 IO-Link module enables connection of up to eight IO-Link devices. These can be IO-Link box modules, actuators, sensors or combinations of both. A point-to-point connection is used between the module and the device. The EtherCAT P Box is parameterized via the EtherCAT master. IO-Link is designed as an intelligent link between the fieldbus level and the sensor, wherein parameterization information can be exchanged bidirectionally via the IO-Link connection. The parameterization of the IO-Link devices with service data can take place from TwinCAT via ADS or, very conveniently, via the integrated IO-Link configuration tool. In addition to the IO-Link channels, the EPP6228-0022 features eight digital inputs on pin 2 of the respective M12 socket.

In the default setting, the eight C/Q channels of the EPP6228-0022 operate as IO-Link channels. Each IO-Link port can also optionally be used just as an input or output.

#### Quick links

- [Technical data \[▶ 22\]](#)
- [Process image \[▶ 24\]](#)
- [Dimensions \[▶ 33\]](#)
- [IO-Link-connection \[▶ 44\]](#)

### 3.3.1 Technical data

All values are typical values over the entire temperature range, unless stated otherwise.

EtherCAT P	
Connection	2 x M8 socket, 4-pin, P-coded, shielded
Distributed Clocks	yes

Supply voltages	
Connection	See EtherCAT P connection
$U_s$ nominal voltage	24 V <sub>DC</sub> (-15 % / +20 %)
$U_s$ sum current: $I_{s,sum}$	max. 3 A
Current consumption from $U_s$	100 mA + Current consumption of the connected IO-Link devices
Rated voltage $U_p$	24 V <sub>DC</sub> (-15 % / +20 %)
$U_p$ sum current: $I_{p,sum}$	max. 3 A
Current consumption from $U_p$	None. $U_p$ is only forwarded.

IO-Link	
Number of ports Class A	8
Connection	8x M12 socket, 4-pin, A-coded
Cable length	max. 20 m
Specification	IO-Link V1.1
Data rates	COM1: 4.8 kbit/s COM2: 38.4 kbit/s COM3: 230.4 kbit/s
Sensor power supply L+	24 V <sub>DC</sub> from $U_s$
L+ output current	max. 1.4 A per port, short-circuit proof max. 3.0 A in total
Extra power P24	-
C/Q input filter	none (when configured as digital input, see <a href="#">2. Assigning IO-Link device to port n</a> [ <a href="#">▶ 58</a> ])
C/Q output current	max. 200 mA, not short-circuit proof (when configured as digital output, see <a href="#">2. Assigning IO-Link device to port n</a> [ <a href="#">▶ 58</a> ])

Digital inputs	
Number	8
Connection	On pin 2 of the IO-Link ports
Characteristics	Type 3 according to EN 61131-2, compatible with type 1
Input filter	10 $\mu$ s
Signal voltage "0"	-3 ... +5 V
Signal voltage "1"	+11 ... +30 V
Input current	3 mA

Housing data	
Dimensions W × H × D	60 mm × 126 mm × 26.5 mm (without plug connectors)
Weight	approx. 250 g
Installation position	variable
Material	PA6 (polyamide)

Environmental conditions	
Ambient temperature during operation	-25 ... +60 °C -25 ... +55 °C according to cULus
Ambient temperature during storage	-40 ... +85 °C
Vibration resistance, shock resistance	conforms to EN 60068-2-6 / EN 60068-2-27 <a href="#">Additional tests [► 23]</a>
EMC immunity / emission	conforms to EN 61000-6-2 / EN 61000-6-4
Protection class	IP65, IP66, IP67 (conforms to EN 60529)

Approvals / markings	
Approvals / markings *)	CE, cULus [ <a href="#">► 48</a> ]

\*) Real applicable approvals/markings see type plate on the side (product marking).

**Additional tests**

The devices have undergone the following additional tests:

Test	Explanation
Vibration	10 frequency sweeps in 3 axes
	5 Hz < f < 60 Hz displacement 0.35 mm, constant amplitude
	60.1 Hz < f < 500 Hz acceleration 5 g, constant amplitude
Shocks	1000 shocks in each direction, in 3 axes
	35 g, 11 ms

**3.3.2 Scope of supply**

Make sure that the following components are included in the scope of delivery:

- 1x EPP6228-0022
- 2x protective cap for EtherCAT P socket, M8, red (pre-assembled)
- 20 x labels, blank (2 strips of 10)









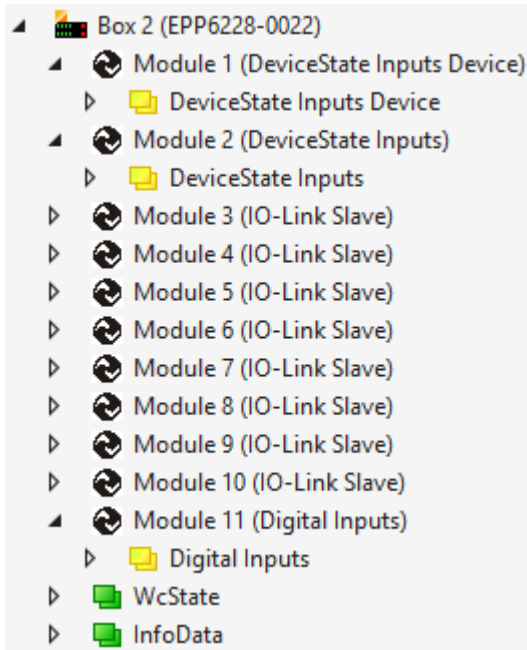

**● Pre-assembled protective caps do not ensure IP67 protection**

**i** Protective caps are pre-assembled at the factory to protect connectors during transport. They may not be tight enough to ensure IP67 protection.

Ensure that the protective caps are correctly seated to ensure IP67 protection.

### 3.3.3 Process image



-  Module 1  
 Diagnostics.  
 See chapter [Further error diagnosis](#) [► 93].
-  Module 2  
 Status variables of the IO-Link ports.  
 See chapter [Status of the IO-Link ports](#) [► 88].
-  Module 3 <sup>1)</sup>  
 Process data of the IO-Link device at port X01
-  Module 4 <sup>1)</sup>  
 Process data of the IO-Link device at port X02
-  Module 5 <sup>1)</sup>  
 Process data of the IO-Link device at port X03
-  Module 6 <sup>1)</sup>  
 Process data of the IO-Link device at port X04
-  Module 7 <sup>1)</sup>  
 Process data of the IO-Link device at port X05
-  Module 8 <sup>1)</sup>  
 Process data of the IO-Link device at port X06
-  Module 9 <sup>1)</sup>  
 Process data of the IO-Link device at port X07
-  Module 10 <sup>1)</sup>  
 Process data of the IO-Link device at port X08
-  Module 11  
 Digital inputs.

<sup>1)</sup> The modules "Module 3" to "Module 10" only exist in the process data if the corresponding IO-Link ports have been configured.

## 4 Basic function principles

### 4.1 IO-Link basics

IO-Link is a communication system for connecting intelligent sensors and actuators to an automation system. The IEC 61131-9 standard specifies IO-Link under the designation "Single-drop digital communication interface for small sensors and actuators" (SDCI).

Both the electrical connection data and the communication protocol are standardized and summarized in the [IO-Link Spec.](#)

#### 4.1.1 IO-Link system layout

An IO-Link system consists of an IO-Link master and one or more IO-Link devices, i.e. sensors or actuators. The IO-Link master provides the interface to the higher-level controller and controls communication with the connected IO-Link devices.

The IO-Link masters from Beckhoff have several IO-Link ports, to each of which one IO-Link device can be connected. IO-Link is not a fieldbus, but rather a point-to-point connection.

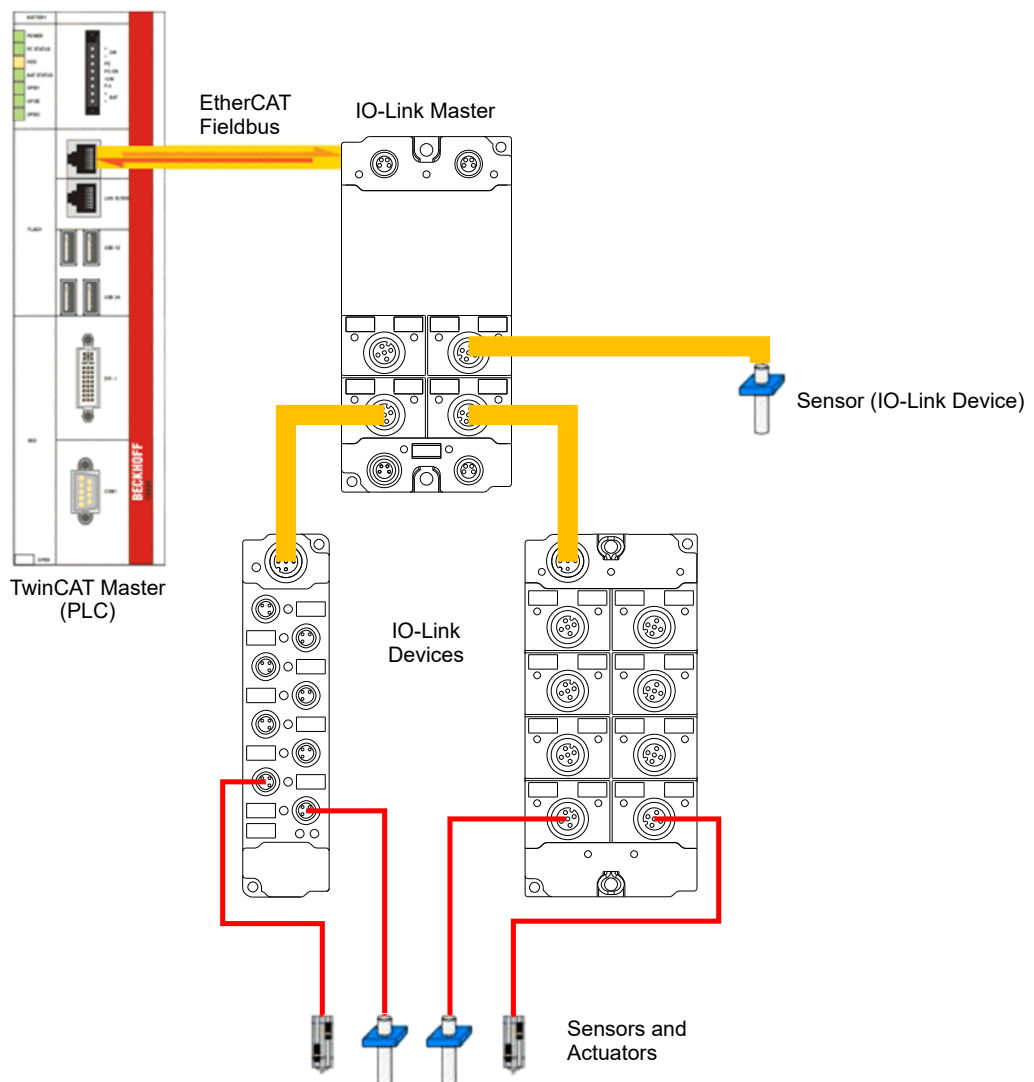

**⚠ CAUTION**

**Risk of device damage**

The IO-Link devices must be supplied from the 24 V power supply of the IO-Link master provided for this purpose. Otherwise, damage to the IO-Link port is possible.

## 4.1.2 Establishment of IO Link communication

The establishment of the IO-Link communication is illustrated in Fig. *Establishment of IO-Link communication*. This illustrates in particular the sequence when automatically scanning [► 59] the IO-Link port.

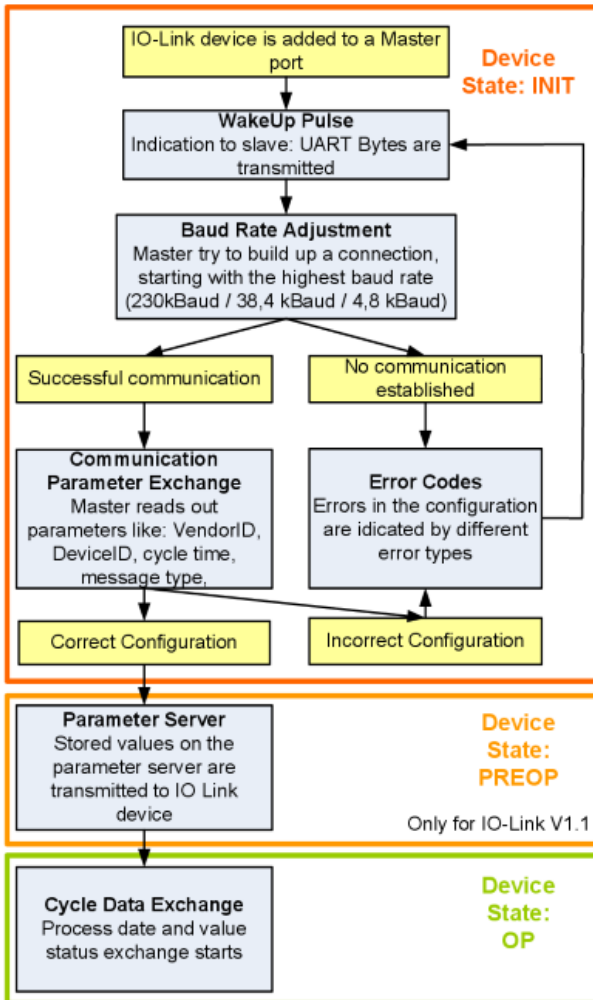

Fig. 1: Establishment of IO Link communication

- If an IO-Link device is connected to a master port, the master attempts to establish communication. A defined signal level, the **wake-up pulse**, signals to the device that UART bytes are to be sent from now on. From this point on, all data will be interpreted by the IO-Link device as UART bytes.
- The master runs through all baud rates [► 27], starting with the fastest baud rate (COM3 = 230 kbaud). A successful connection has been established when the slave responds to the wake-up pulse.
- First of all the master reads the **basic parameters** (Vendor ID, Device ID, process data length, telegram type and cycle time) and compares them with the existing configuration.
- If no connection could be established to the device, or if the saved parameters differ from those read, the corresponding error is output.
- If the saved parameters differ from those read, the IO-Link device changes to the PREOP state. If the IO-Link device specification is V1.1, the parameter server [► 27] is now executed. If the IO-Link device specification is V1.0, this step is omitted and the device changes directly to OP.
- Finally the cycle time is written and the device changes to OP. After that the master cyclically exchanges data with the device.

### 4.1.3 Device description IODD

IO-Link devices possess individual system information in the form of an IO device description (IODD), which contains:

- Communication features
- Device parameters with value range and default values
- Identification, process and diagnostic data
- Device data
- Text description
- Picture of the device
- Vendor's logo

If the IODD is imported, then the device data are automatically detected during [automatic scanning \[► 59\]](#) with TwinCAT and adopted in the System Manager.

### 4.1.4 Parameter server

In order to be able to use the functionality of the parameter server, both the IO-Link master and the IO-Link device must be specified to V1.1. The IO-Link revision of the device can be read for the individual port under [Settings \[► 66\]](#). All IO-Link masters from Beckhoff with current firmware support the IO-Link specification V1.1.

- The parameter server in the IO-Link master contains parameter data that are saved in the IO-Link device. The memory capacity is max. 2 kbyte (including header).  
If the IO-Link device is exchanged, then the data are loaded from the parameter server into the new device. The requirement for this is that the device is of the same type (VendorID and DeviceID must be the same).
- If a new IO-Link device is configured, then the IO-Link master loads the parameters from the IO-Link device into the parameter server when starting for the first time.  
Data from other IO-Link devices that are already configured (VendorID and DeviceID do not correspond to the configured device) are overwritten.
- At each further start the IO-Link master uses a checksum to check whether the data in the parameter server correspond to those on the IO-Link device and if necessary downloads them to the device.
- If the parameters change during the device runtime, this can be reported to the Master via the [store button \[► 74\]](#) ([ParamDownloadStore \[► 75\]](#)). The master then starts the parameter server with an upload.
- By default the event is not set each time the parameters are written, therefore the end of the parameterization procedure has to be reported to the IO-Link device via the [store button \[► 74\]](#) ([ParamDownloadStore \[► 75\]](#)).  
The IO-Link device then sends the corresponding event to the master. The data are loaded into the parameter server.
- In the case of a pre-programmed IO-Link device, no download takes place from the parameter server to the device.

### 4.1.5 Data transfer rate

An IO-Link master according to specification V1.1 supports all three transmission methods and automatically adjusts the baud rate to that of the IO-Link device.

An IO-Link device usually supports only one baud rate. IO-Link devices with different baud rates can be connected to the various ports of the master.

- COM1 = 4.8 kbaud
- COM2 = 38.4 kbaud
- COM3 = 230.4 kbaud

## 4.2 Timestamp inputs (EPP6224-0522)

Timestamp inputs are digital inputs that detect signal edges with very high-resolution timing.

In contrast to digital inputs without a timestamp function, timestamp inputs are event-driven: When a signal edge is detected, the current timestamp is saved in the device. The saved timestamp is transferred to the controller with the cyclic process data in the following EtherCAT cycle.

The timestamp is obtained from the EtherCAT distributed clocks (DC). This means that the timestamps are comparable with the timestamps of other DC-capable EtherCAT devices across the network (deviations typically well below 1  $\mu\text{s}$ , depending on the topology).

The resolution of the distributed clocks and therefore the timestamps is 1 ns.

### Possibilities and limits

- Only one rising and one falling signal edge is saved per EtherCAT cycle. You can set whether the timestamp of the first or last signal edge should be saved for several signal edges per EtherCAT cycle.
- The high input sensitivity makes the inputs susceptible to interference from effects such as.
  - Bouncing
  - EMC

This may lead to increased demands on the cabling and the signal transducer (sensor, switch, ...).

### Example

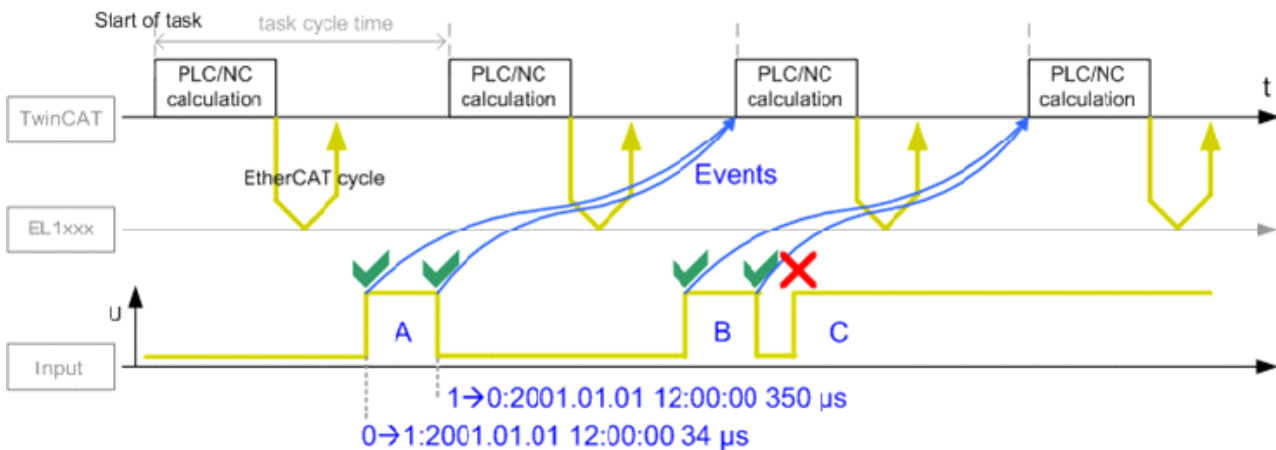

In this figure, the rising and falling edges of pulse A are each recorded as events with a timestamp and transferred to the controller in the subsequent EtherCAT cycle. The temporal resolution is 1 ns here – an ‘infinitely’ fine time resolution in mechanical terms. The device only saves one falling and one rising edge per cycle. If several edge changes occur, such as the rising edge of pulse C, the first or last event is saved, depending on the configuration.

## 5 Mounting

### 5.1 EPP6224-0002

#### 5.1.1 Dimensions

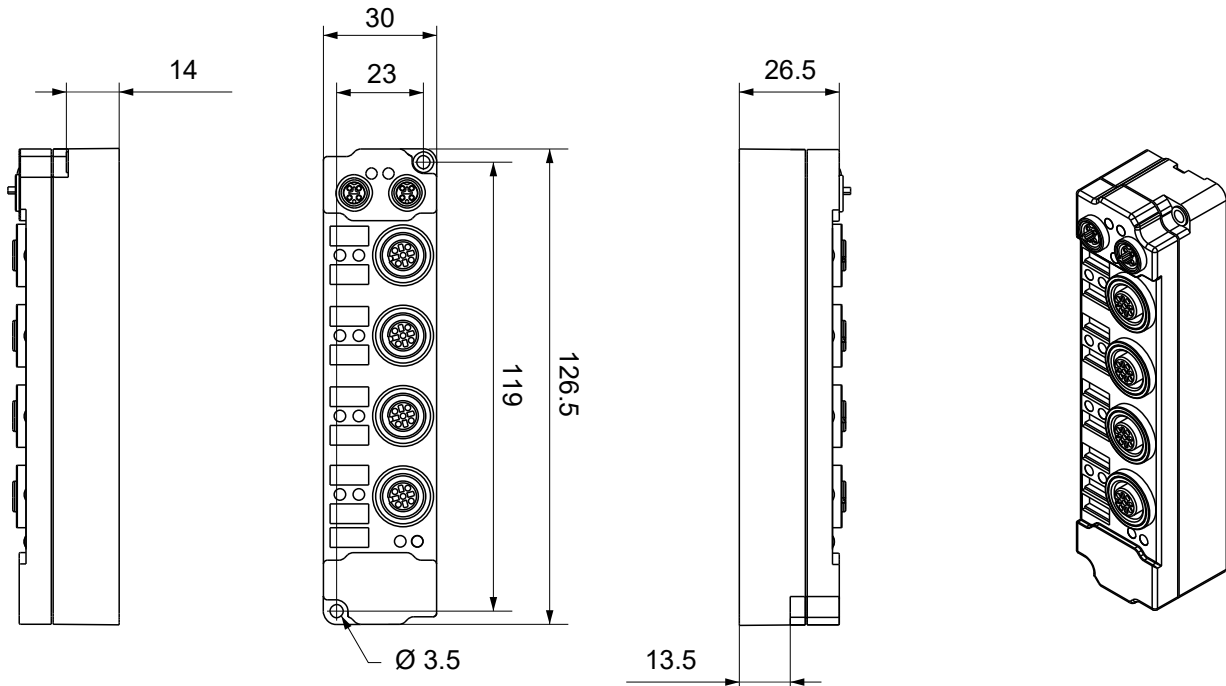

All dimensions are given in millimeters.  
The drawing is not true to scale.

#### Housing features

Housing material	PA6 (polyamide)
Sealing compound	polyurethane
Mounting	two mounting holes Ø 3.5 mm for M3
Metal parts	brass, nickel-plated
Contacts	CuZn, gold-plated
Installation position	variable
Protection class	IP65, IP66, IP67 (conforms to EN 60529) when screwed together
Dimensions (H × W × D)	approx. 126 × 30 × 26.5 mm (without connectors)

## 5.1.2 Mounting

Mount the module with two M3 screws on the mounting holes in the corners of the module. The mounting holes have no thread.

## 5.1.3 Functional earth

The upper mounting holes also serves as a connection for functional earth (FE).

Make sure that the box is grounded to low impedance via the functional earth (FE) connection. You can achieve this, for example, by mounting the box on a grounded machine bed.



Fig. 2: Connection for functional earth (FE)

## 5.2 EPP6224-0522

### 5.2.1 Dimensions

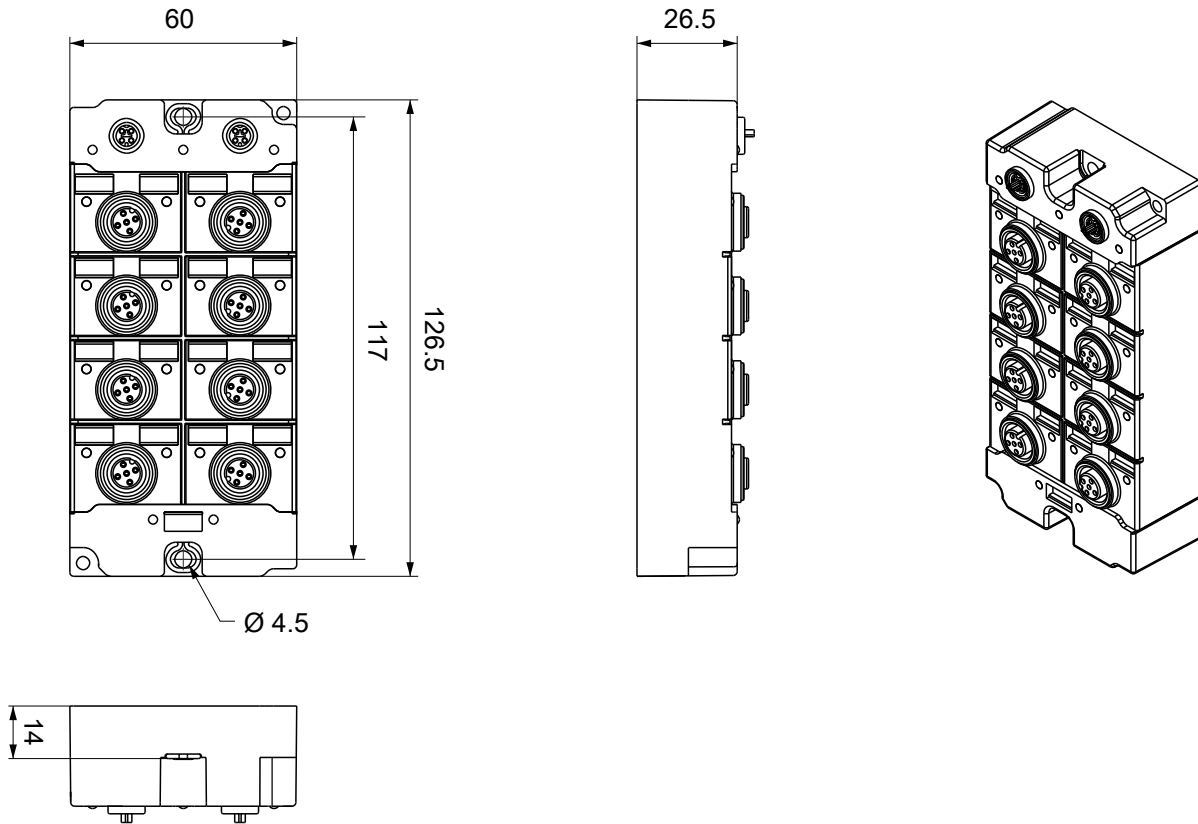

All dimensions are given in millimeters.  
The drawing is not true to scale.

#### Housing features

Housing material	PA6 (polyamide)
Sealing compound	polyurethane
Mounting	two mounting holes Ø 4.5 mm for M4
Metal parts	brass, nickel-plated
Contacts	CuZn, gold-plated
Installation position	variable
Protection class	IP65, IP66, IP67 (conforms to EN 60529) when screwed together
Dimensions (H × W × D)	approx. 126 × 60 × 26.5 mm (without connectors)

## 5.2.2 Mounting

Mount the module with two M4 screws in the centrally located mounting holes.

## 5.2.3 Functional earth

The mounting holes also serve as connections for the functional earth (FE).

Make sure that the box is grounded to low impedance via the functional earth (FE) connections. You can achieve this, for example, by mounting the box on a grounded machine bed.

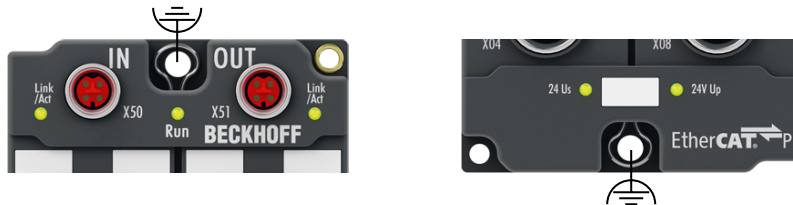
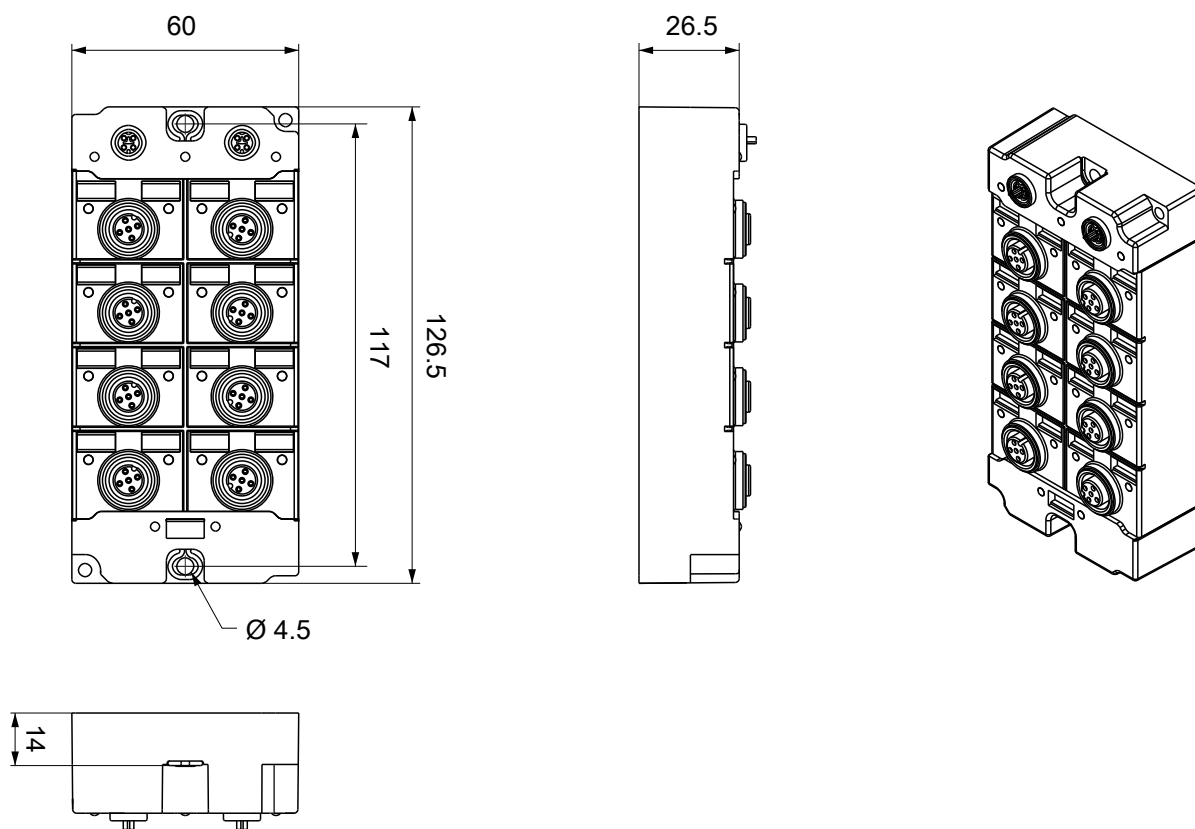

Fig. 3: Connection for functional earth (FE)

## 5.3 EPP6228-0022

### 5.3.1 Dimensions



All dimensions are given in millimeters.  
The drawing is not true to scale.

#### Housing features

Housing material	PA6 (polyamide)
Sealing compound	polyurethane
Mounting	two mounting holes Ø 4.5 mm for M4
Metal parts	brass, nickel-plated
Contacts	CuZn, gold-plated
Installation position	variable
Protection class	IP65, IP66, IP67 (conforms to EN 60529) when screwed together
Dimensions (H × W × D)	approx. 126 × 60 × 26.5 mm (without connectors)

### 5.3.2 Mounting

Mount the module with two M4 screws in the centrally located mounting holes.

### 5.3.3 Functional earth

The mounting holes also serve as connections for the functional earth (FE).

Make sure that the box is grounded to low impedance via the functional earth (FE) connections. You can achieve this, for example, by mounting the box on a grounded machine bed.

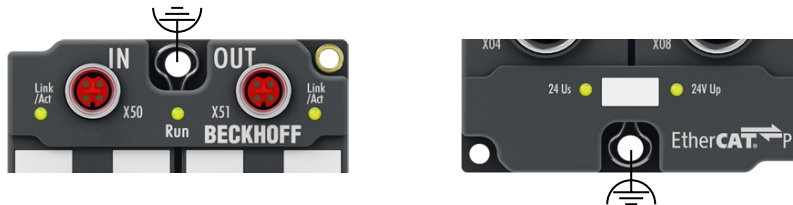

Fig. 4: Connection for functional earth (FE)

## 6 Connection

### NOTICE

#### Only plug and unplug in a de-energized state

Connecting and disconnecting connectors under voltage or load can lead to damage.

- De-energize the device before connecting or disconnecting the connectors
- Only switch on the supply voltages after connection

### 6.1 Tightening torques for plug connectors

Tighten the connectors using a torque wrench. (e.g., Beckhoff ZB8801)

Connector diameter	Tightening torque
M8	0.4 Nm
M12	0.6 Nm

## 6.2 EtherCAT P

### ⚠ WARNING

#### Power supply from SELV/PELV power supply unit

SELV/PELV circuits (Safety Extra Low Voltage, Protective Extra Low Voltage) according to IEC 61010-2-201 must be used to supply the EtherCAT P Power Sourcing Device (PSD).

Notes:

- SELV/PELV circuits may give rise to further requirements from standards such as IEC 60204-1 et al, for example with regard to cable spacing and insulation.
- A SELV supply provides safe electrical isolation and limitation of the voltage without a connection to the protective conductor.  
A PELV supply also requires a safe connection to the protective conductor.

### ⚠ CAUTION

#### Observe the UL requirements

- When operating under UL conditions, observe the warnings in the chapter [UL Requirements \[▶ 48\]](#).

EtherCAT P transmits two supply voltages:

- **Control voltage  $U_s$**   
The following sub-functions are supplied from the control voltage  $U_s$ :
  - the fieldbus
  - the processor logic
  - typically the inputs and the sensors if the EtherCAT P Box has inputs.
- **Peripheral voltage  $U_p$**   
The digital outputs are typically supplied from the peripheral voltage  $U_p$  for EtherCAT P Box modules with digital outputs.  $U_p$  can be supplied separately. If  $U_p$  is switched off, the fieldbus function, the function of the inputs and the supply of the sensors are maintained.

The exact assignment of  $U_s$  and  $U_p$  can be found in the pin assignment of the I/O connections.

#### Redirection of the supply voltages

The supply voltages are passed on internally from the "IN" connection to the "OUT" connection. Hence, the supply voltages  $U_s$  and  $U_p$  can be passed from one EtherCAT P Box to the next EtherCAT P Box in a simple manner.

### NOTICE

#### Note the maximum current.

Ensure that the maximum permitted current of 3 A for the M8 connectors is not exceeded when redirecting EtherCAT P.

### 6.2.1 Connectors

**NOTICE**

**Risk of damage to the device!**  
 Bring the EtherCAT/EtherCAT P system into a safe, powered down state before starting installation, disassembly or wiring of the modules!

Two M8 sockets at the upper end of the modules are provided for supply and downstream connection of EtherCAT P:

- IN: left M8 socket for EtherCAT P supply
- OUT: right M8 socket for downstream connection of EtherCAT P

The metal threads of the M8 EtherCAT P sockets are internally linked to the FE connection via high impedance RC combination. See chapter [Functional earth \[▶ 30\]](#).



Fig. 5: Connectors for EtherCAT P

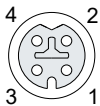

Fig. 6: M8 socket, p-coded

Contact	Signal	Voltage	Core color <sup>1)</sup>
1	Tx +	GND <sub>S</sub>	yellow
2	Rx +	GND <sub>P</sub>	white
3	Rx -	U <sub>P</sub> : peripheral voltage, +24 V <sub>DC</sub>	blue
4	Tx -	U <sub>S</sub> : control voltage, +24 V <sub>DC</sub>	orange
Housing	Shield	Shield	Shield

<sup>1)</sup> The core colors apply to EtherCAT P cables and ECP cables from Beckhoff.

## 6.2.2 Status LEDs

### 6.2.2.1 Supply voltages



EtherCAT P Box modules indicate the status of the supply voltages via two status LEDs. The status LEDs are labeled with the designations of the supply voltages: U<sub>s</sub> and U<sub>p</sub>.

LED	Display	Meaning
U <sub>s</sub> (control voltage)	off	The supply voltage U <sub>s</sub> is not available.
	green illuminated	The supply voltage U <sub>s</sub> is available.
U <sub>p</sub> (peripheral voltage)	off	The supply voltage U <sub>p</sub> is not available.
	green illuminated	The supply voltage U <sub>p</sub> is available.

### 6.2.2.2 EtherCAT



#### L/A (Link/Act)

A green LED labeled "L/A" or "Link/Act" is located next to each EtherCAT/EtherCAT P socket. The LED indicates the communication state of the respective socket:

LED	Meaning
off	no connection to the connected EtherCAT device
lit	LINK: connection to the connected EtherCAT device
flashes	ACT: communication with the connected EtherCAT device

#### Run

Each EtherCAT slave has a green LED labelled "Run". The LED signals the status of the slave in the EtherCAT network:

LED	Meaning
off	Slave is in "Init" state
flashes uniformly	Slave is in "Pre-Operational" state
flashes sporadically	Slave is in "Safe-Operational" state
lit	Slave is in "Operational" state

Description of the EtherCAT slave states

### 6.2.3 Conductor losses

Take into account the voltage drop on the supply line when planning a system. Avoid the voltage drop being so high that the supply voltage at the box lies below the minimum nominal voltage. Variations in the voltage of the power supply unit must also be taken into account.

#### **i** Planning tool for EtherCAT P

You can plan cable lengths, voltages and currents of your EtherCAT P system using TwinCAT 3. The requirement for this is TwinCAT 3 Build 4020 or higher.

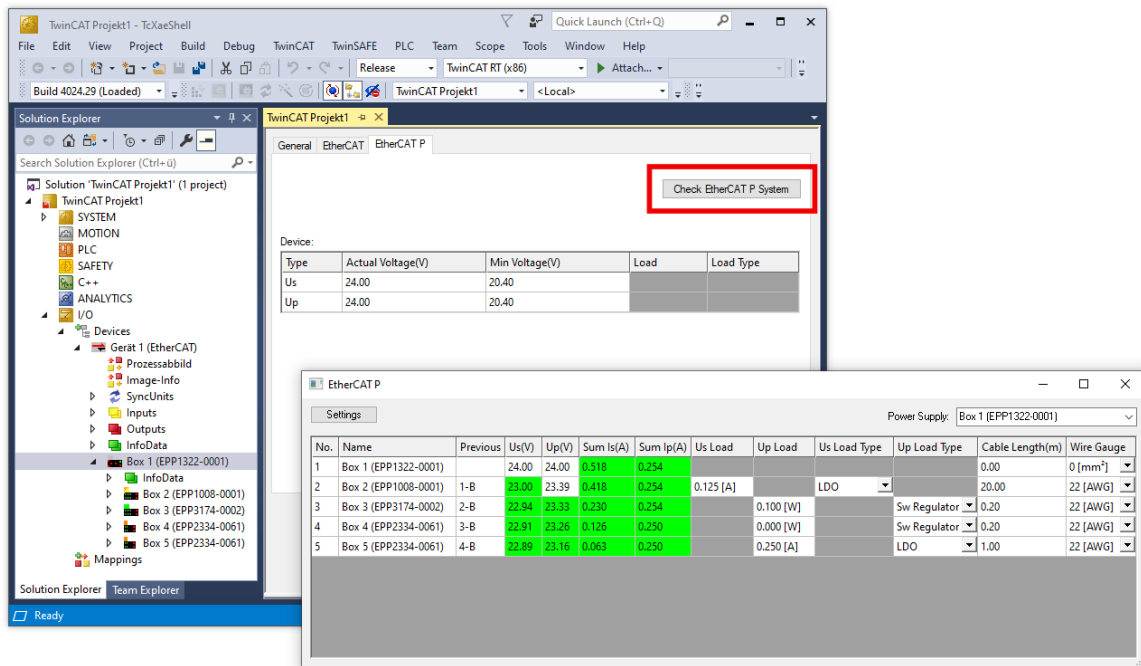

Further information can be found in the quick start guide [IO configuration in TwinCAT](#) in chapter "Configuration of EtherCAT P via TwinCAT".

#### Voltage drop on the supply line

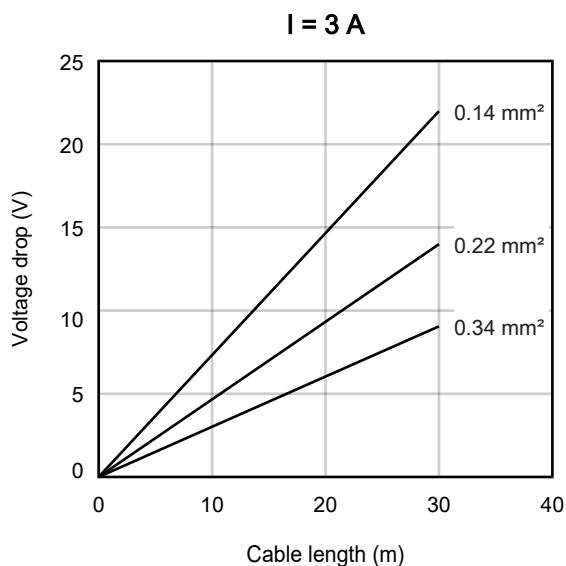

## 6.3 IO-Link ports

### 6.3.1 EPP6224-0002

#### NOTICE

##### Incorrect signal levels due to electromagnetic interference

The digital inputs on the pins 2 are optimized for high-speed signal transmission and are therefore susceptible to electromagnetic interference.

Under the influence of electromagnetic interference, a false signal level can be detected.

- If necessary, use shielded signal lines.

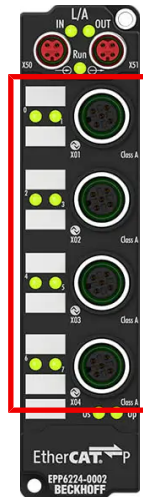

One IO-Link port is available at each of the M12 sockets X01, X02, X03 and X04.

#### Pin assignment

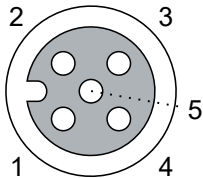

Pin	Symbol	Function
1	L+	Supply voltage output: 24 V <sub>DC</sub> from U <sub>S</sub>
2	DI	Digital input
3	L-	Reference ground GND <sub>S</sub>
4	C/Q	IO-Link data line
5	n.c.	--

### 6.3.1.1 Status LEDs

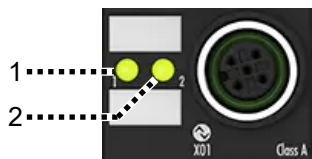

#### 1: IO-Link status

LED signal	Meaning
off	Possibilities: <ul style="list-style-type: none"> <li>• Port not configured</li> <li>• Logic level low <sup>1)</sup></li> </ul>
red illuminated flashes sporadically green	Possibilities: <ul style="list-style-type: none"> <li>• IO-Link connection attempt</li> <li>• No IO-Link device connected</li> <li>• Incorrect IO-Link device connected</li> <li>• IO-Link device defective</li> </ul>
flashing green	IO-Link communication active
green illuminated	Logic level high <sup>1)</sup>

<sup>1)</sup> Port configured as digital input or output

#### 2: Status of the digital input on pin 2

The LED lights up when a high level is present on the digital input DI.

### 6.3.2 EPP6224-0522

**NOTICE**

**Incorrect signal levels due to electromagnetic interference**

The digital inputs on the pins 2 are optimized for high-speed signal transmission and are therefore susceptible to electromagnetic interference.

Under the influence of electromagnetic interference, a false signal level can be detected.

- If necessary, use shielded signal lines.

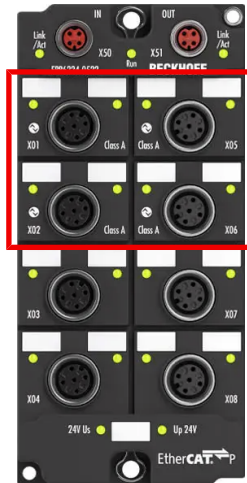

One IO-Link port is available at each of the M12 sockets X01, X02, X05 and X06.

**Pin assignment**

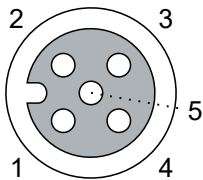

Pin	Symbol	Function
1	L+	Supply voltage output: 24 V <sub>DC</sub> from U <sub>S</sub>
2	DI	Digital input with timestamp
3	L-	Reference ground GND <sub>S</sub>
4	C/Q	IO-Link data line
5	n.c.	--

**6.3.2.1 Status LEDs**



**1: IO-Link status**

LED signal	Meaning
off	Possibilities: <ul style="list-style-type: none"> <li>• Port not configured</li> <li>• Logic level low <sup>1)</sup></li> </ul>
red illuminated flashes sporadically green	Possibilities: <ul style="list-style-type: none"> <li>• IO-Link connection attempt</li> <li>• No IO-Link device connected</li> <li>• Incorrect IO-Link device connected</li> <li>• IO-Link device defective</li> </ul>
flashing green	IO-Link communication active
green illuminated	Logic level high <sup>1)</sup>

<sup>1)</sup> Port configured as digital input or output

**2: Status of the digital input on pin 2**

The LED lights up when a high level is present on the digital input DI.

### 6.3.3 EPP6228-0022

**NOTICE**

**Incorrect signal levels due to electromagnetic interference**

The digital inputs on the pins 2 are optimized for high-speed signal transmission and are therefore susceptible to electromagnetic interference.

Under the influence of electromagnetic interference, a false signal level can be detected.

- If necessary, use shielded signal lines.

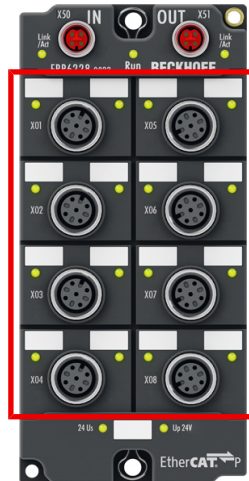

One IO-Link port is available at each of the M12 sockets X01 to X08.

**Pin assignment**

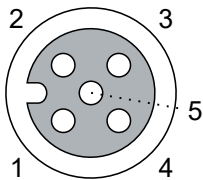

Pin	Symbol	Function
1	L+	Supply voltage output: 24 V <sub>DC</sub> from U <sub>S</sub>
2	DI	Digital input
3	L-	Reference ground GND <sub>S</sub>
4	C/Q	IO-Link data line
5	n.c.	--

**6.3.3.1 Status LEDs**



**1: IO-Link status**

LED signal	Meaning
off	Possibilities: <ul style="list-style-type: none"> <li>• Port not configured</li> <li>• Logic level low <sup>1)</sup></li> </ul>
red illuminated flashes sporadically green	Possibilities: <ul style="list-style-type: none"> <li>• IO-Link connection attempt</li> <li>• No IO-Link device connected</li> <li>• Incorrect IO-Link device connected</li> <li>• IO-Link device defective</li> </ul>
flashing green	IO-Link communication active
green illuminated	Logic level high <sup>1)</sup>

<sup>1)</sup> Port configured as digital input or output

**2: Status of the digital input on pin 2**

The LED lights up when a high level is present on the digital input DI.

## 6.4 Digital-combi-channels (EPP6224-0522 only)

**⚠ CAUTION**

**Risk of supply voltage feedback**

If you supply a connected sensor from an external voltage source, this external voltage can be fed back to  $U_P$  via the digital combi channel (pin 2 or pin 4).

This means that  $U_P$  can continue to be present even when the  $U_P$  power supply is switched off (e.g. via emergency shutdown). The box module and other devices connected to  $U_P$  may continue to be supplied with power unnoticed. Injuries and property damage are possible.

- Only supply connected sensors from the supply voltage on pin 1.

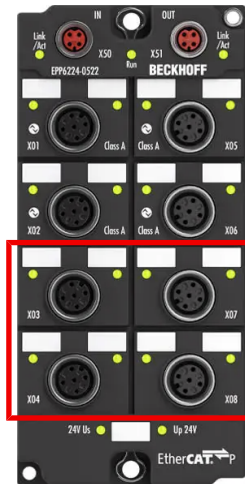

Two digital combi channels are available at each of the M12 sockets X03, X04, X07 and X08. Each digital combi channel can be operated either as a digital input or as a digital output.

**Pin assignment**

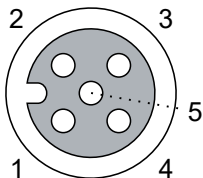

Pin	Symbol	Function
1	+24 V $U_P$	Sensor power supply: 24 V <sub>DC</sub> from $U_P$
2	In-/Output B	Digital input / digital output
3	GND <sub>p</sub>	GND <sub>P</sub>
4	In-/Output A	Digital input / digital output
5	⏏	Functional earth

The same earth potential is available at pin 5 that is applied to the functional earth connections of the box module (Functional earth (FE)).

**Behavior under short-circuit conditions**

- The sensor power supply on pin 1 is short-circuit proof.  
If the sensor power supply is short-circuited on one of the connections, the sensor power supply on all four connections is shut down for the duration of the short circuit.
- The digital outputs are short-circuit proof.  
A short circuit on one of the digital outputs does not affect any other functions of the box module.

### 6.4.1 Status LEDs

The status of each digital combi channel is displayed via a status LED. The status LEDs are located next to the corresponding connections:



LED display	Meaning
Off	Low level
Lights up green	High level

## 6.5 UL Requirements

The installation of the EtherCAT Box Modules certified by UL has to meet the following requirements.

### Supply voltage

#### ⚠ CAUTION

##### CAUTION!

This UL requirements are valid for all supply voltages of all marked EtherCAT Box Modules!  
For the compliance of the UL requirements the EtherCAT Box Modules should only be supplied

- by a 24 V<sub>DC</sub> supply voltage, supplied by an isolating source and protected by means of a fuse (in accordance with UL248), rated maximum 4 Amp, or
- by a 24 V<sub>DC</sub> power source, that has to satisfy *NEC class 2*.  
A *NEC class 2* power supply shall not be connected in series or parallel with another (class 2) power source!

#### ⚠ CAUTION

##### CAUTION!

To meet the UL requirements, the EtherCAT Box Modules must not be connected to unlimited power sources!

### Networks

#### ⚠ CAUTION

##### CAUTION!

To meet the UL requirements, EtherCAT Box Modules must not be connected to telecommunication networks!

### Ambient temperature range

#### ⚠ CAUTION

##### CAUTION!

To meet the UL requirements, EtherCAT Box Modules has to be operated only at an ambient temperature range of -25 °C to +55 °C!

### Marking for UL

All EtherCAT Box Modules certified by UL (Underwriters Laboratories) are marked with the following label.



Fig. 7: UL label

## 7 Commissioning and configuration

### 7.1 Integrating into a TwinCAT project

The procedure for integration in a TwinCAT project is described in these [Quick start guide](#).

## 7.2 Timestamp inputs (EPP6224-0522 only)

A timestamp input provides two timestamps in the process data:

- The timestamp of the last recorded rising signal edge “LatchPos”
- The timestamp of the last recorded falling signal edge “LatchNeg”

Each time a signal edge is recorded, the corresponding timestamp is overwritten with the current timestamp.

### 7.2.1 Configuring process data

You can configure the process data of the timestamp inputs to remove any unnecessary information from the process image.

1. Open the "Slots" tab and choose the "Timestamp" slot

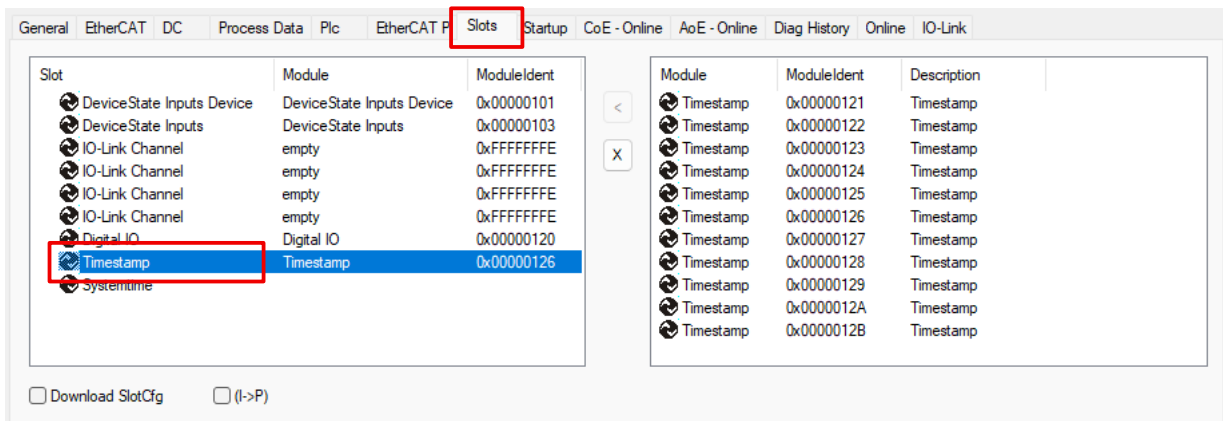

2. Choose the module according to the required process data, see the following table

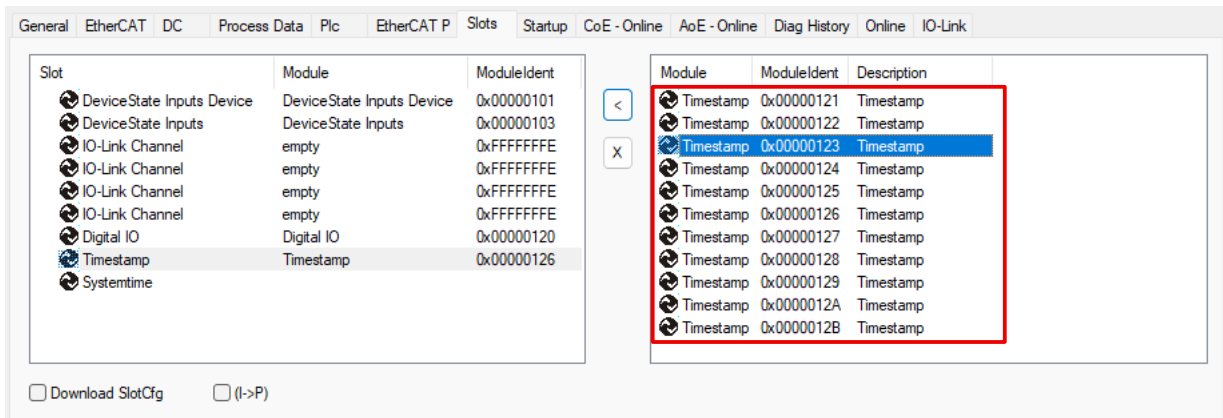

ModuleIdnt	Activated process data in the PDO "Module 8 (Timestamp)"
0x00000121	Status1, Status2, Status3, Status4
0x00000122	Status1; LatchPos1
0x00000123	Status1; LatchPos1; LatchNeg1
0x00000124	Status1, Status2; LatchPos1, LatchPos2; LatchNeg1, LatchNeg2
0x00000125	Status1, Status2, Status3; LatchPos1, LatchPos2, LatchPos3; LatchNeg1, LatchNeg2, LatchNeg3
0x00000126 (Default)	Status1, Status2, Status3, Status4; LatchPos1, LatchPos2, LatchPos3, LatchPos4; LatchNeg1, LatchNeg2, LatchNeg3, LatchNeg4
0x00000127	LatchPos1, LatchPos2; LatchNeg1, LatchNeg2
0x00000128	LatchPos1, LatchPos2, LatchPos3; LatchNeg1, LatchNeg2, LatchNeg3
0x00000129	LatchPos1, LatchPos2, LatchPos3, LatchPos4; LatchNeg1, LatchNeg2, LatchNeg3, LatchNeg4
0x0000012A	LatchPos1, LatchPos2, LatchPos3, LatchPos4
0x0000012B	LatchNeg1, LatchNeg2, LatchNeg3, LatchNeg4

3. Assign the module to the "Timestamp" slot

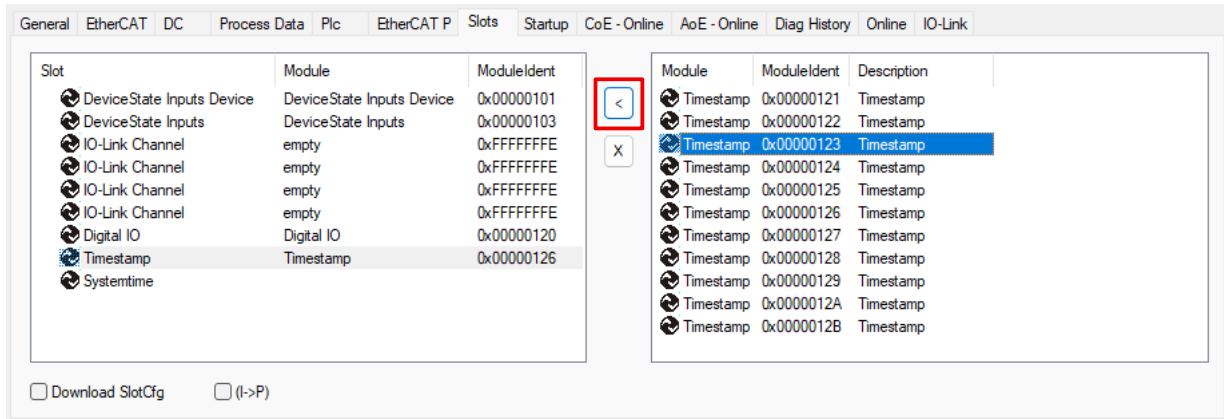

⇒ The ModuleId of the selected module is displayed next to the slot

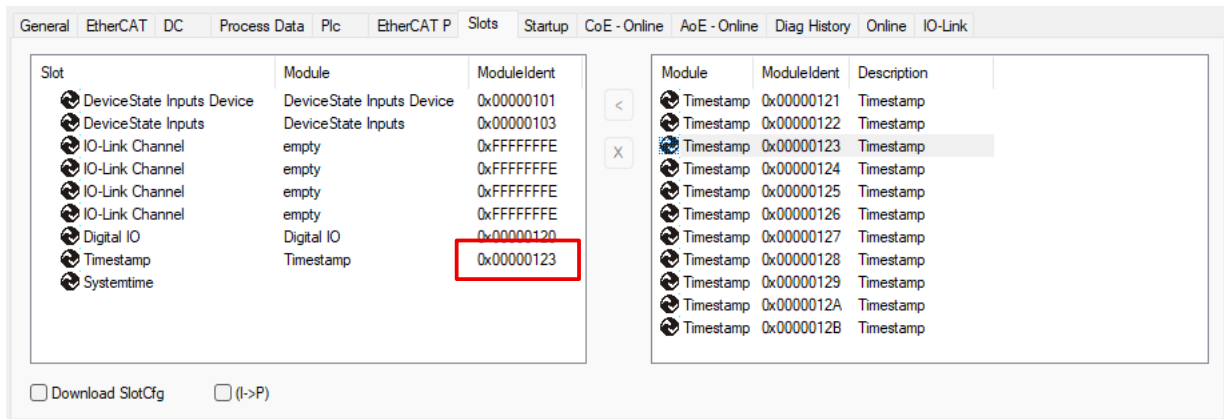

## 7.2.2 Configuration for multiple edges per PLC cycle

The timestamp of the last recorded rising or falling signal edge is transferred to the controller once per PLC cycle. If several signal edges occur within a PLC cycle, only the timestamps of one rising and one falling signal edge are transferred.

You can set which timestamp is to be transferred in such a case:

- The timestamp of the *first* detected signal edge in the PLC cycle
- The timestamp of the *last* detected signal edge in the PLC cycle (default)

This setting can be made separately for rising and falling signal edges.

### Procedure

The setting is made via one control register per channel:

Channel	Control register
1	0x09A8
2	0x09A9
3	0x09AA
4	0x09AB

To write the desired value to the register, use the FB\_EcPhysicalWriteCmd function block from the Tc2\_EtherCAT.lib library, for example.

Use bit 0 of the register to configure the detection of rising edges and bit 1 to configure the detection of falling edges:

Bit 7	Bit 6	Bit 5	Bit 4	Bit 3	Bit 2	Bit 1	Bit 0
-	-	-	-	-	-	Falling edges	Rising edges

To do this, set the corresponding bit according to the following table:

Bit value	Name	Saved signal edge
0	Continuous (default)	Last signal edge in the PLC cycle
1	Single Event	First signal edge in the PLC cycle

### Status byte

The status bytes "Status1" to "Status4" in the process data show what happened in the previous EtherCAT cycle for the respective channel. The meaning of the bits of the status byte depends on the configuration described above:

Bit 7	Bit 6	Bit 5	Bit 4	Bit 3	Bit 2	Bit 1	Bit 0
			-	-	Current signal level	Falling edge detected <sup>1)</sup>	Rising edge detected <sup>2)</sup>

<sup>1)</sup> Only active if bit 1 is set in the control register.

<sup>2)</sup> Only active if bit 0 is set in the control register.

## 7.3 Configuration of the IO link master

### **i** EtherCAT XML device description and configuration files

The display matches that of the CoE objects from the EtherCAT XML Device Description. We recommend downloading the latest XML file from the download area of the [Beckhoff website](#) and installing it according to installation instructions.

When adding the IO-Link master (see chapter [Integrating into a TwinCAT project \[▶ 49\]](#)) in the TwinCAT System Manager, an additional tab called "IO-Link" is created (fig. *IO-Link tab*). A detailed description can be found in chapter [Configuration of the IO-Link devices \[▶ 54\]](#)

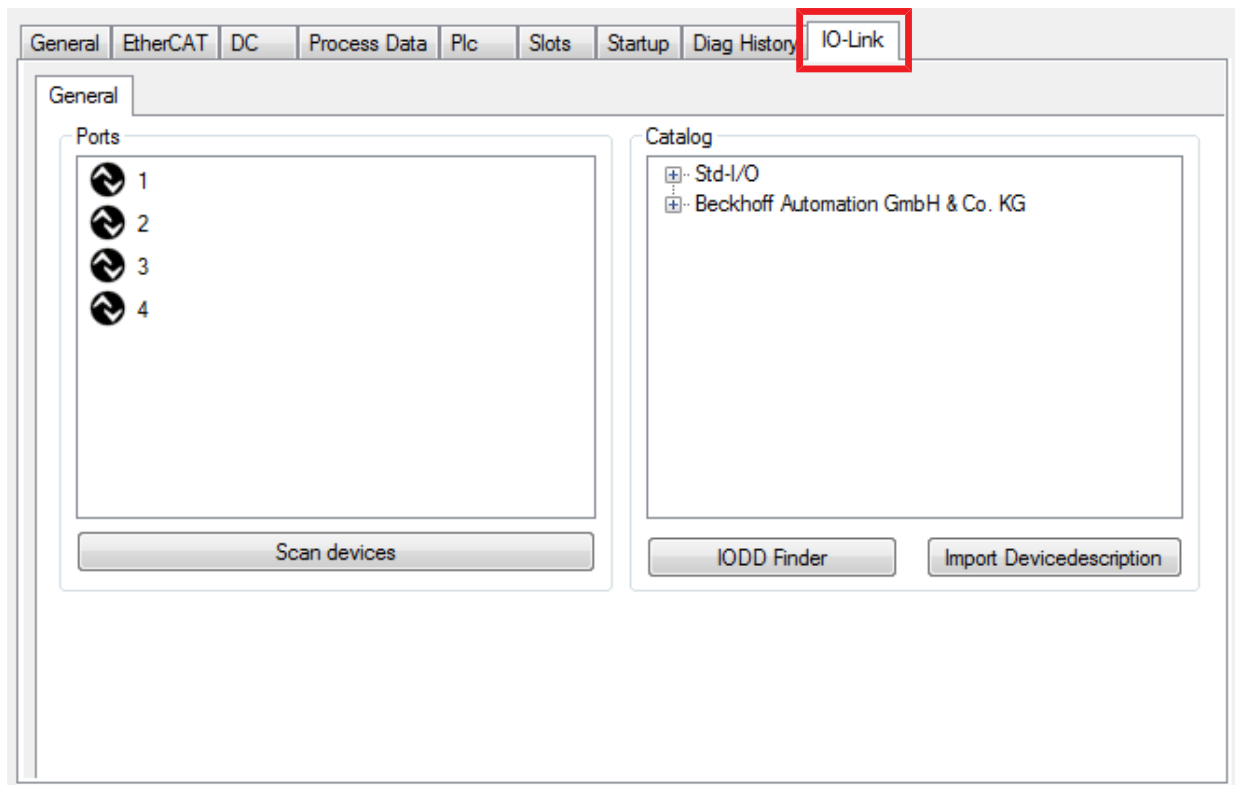

Fig. 8: "IO Link" tab

### **i** IO-Link Extension

If the tab "IO-Link" is not displayed, the associated System Manager extension is missing. The System Manager extension is required for TwinCAT version 2.10, build 1325 to 1330.

- If your System Manager version or TwinCAT 3 does not yet provide this support, it can be installed later if necessary. Please contact our [Support \[▶ 142\]](#).

## 7.4 Configuration of the IO-Link devices

The configuration of the IO link devices is carried out in the IO link configuration tool. Configure the IO link device as described below.

- ✓ Requirement: an IO-Link master has been added in the Solution Explorer under the "I/O" entry.
- 1. [Open the IO link configuration tool \[► 54\]](#).
- 2. [Import the IODD file of the IO link device \[► 58\]](#).
- 3. Assign devices to ports.
  - ⇒ [Assign a device to a port \[► 55\]](#).
  - ⇒ [Configure a port as digital in- or output \[► 58\]](#).
- 4. [Remove a device from a port \[► 64\]](#).
- 5. [Activate the IO link configuration \[► 65\]](#), so that changes become effective.

### 7.4.1 Open the IO link configuration tool

- ✓ Requirement: an IO-Link master has been added in the Solution Explorer under the "I/O" entry.
- 1. Double-click on the IO-Link master.
  - ⇒ A device editor for the IO-Link master opens.
- 2. Click on the "IO-Link" tab.
  - ⇒ The IO-Link configuration tool opens. The configuration tool contains two fields:
    - „Ports“  
The left-hand field "Ports" shows a list of the ports of the IO-Link master. If a device has been assigned to a port, the device designation is shown next to the port.
    - „Catalog“  
The right-hand field "Catalog" shows the device catalog.  
The device catalog contains an alphabetically sorted list of the IO-Link devices for which a device description (IODD) exists in the local TwinCAT installation.  
The IODDs for the EPIxxxx, ERlxxxx IO-Link Box modules from Beckhoff can be downloaded via the [Download finder](#). The downloaded zip file contains the IODD device description files for the Beckhoff EPIxxxx, ERlxxxx IO-Link Box modules.

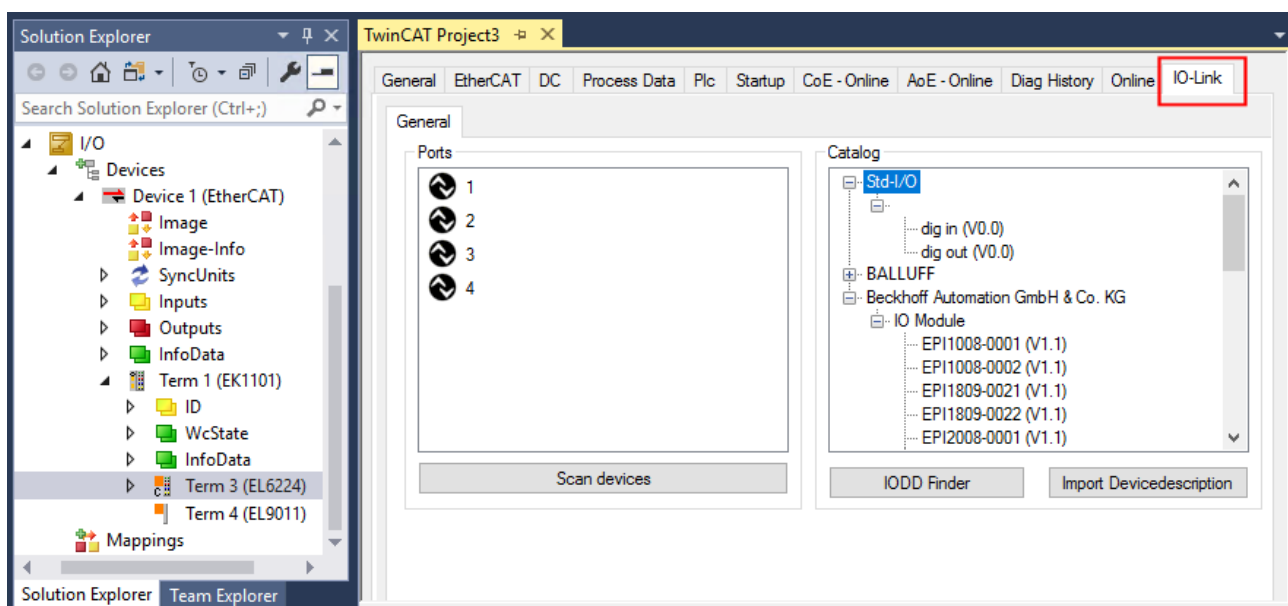

Fig. 9: IO-Link configuration tool

## 7.4.2 Integrating IO-Link devices

The integration of the IODD file should always be the first step, since this enables the breakdown of the individual process data of the IO-Link devices as well as the display of the parameters.

There are several ways of integrating an IO-Link device:

1. Importing the IODD file (offline and online) via
  - ⇒ button Import Devicedescription [▶ 56] (A) or
  - ⇒ button IODD Finder [▶ 56] (B)
2. Select the device in the "Catalog" field and assign it to a port [▶ 58].
3. Automatic scanning of the IO-Link ports (online) via
  - ⇒ button Scan devices [▶ 59] (C)
4. Manual insertion (offline and online) via
  - ⇒ menu Create Device [▶ 63] (D)

### **i** Application note

- If the IODD is not available, the IO-Link device should be integrated online by scanning.
- Manual integration of the IO-Link devices via "Create Device" should only be carried out if the IODD of the vendor and the IO-Link device are not available at the time of project creation.

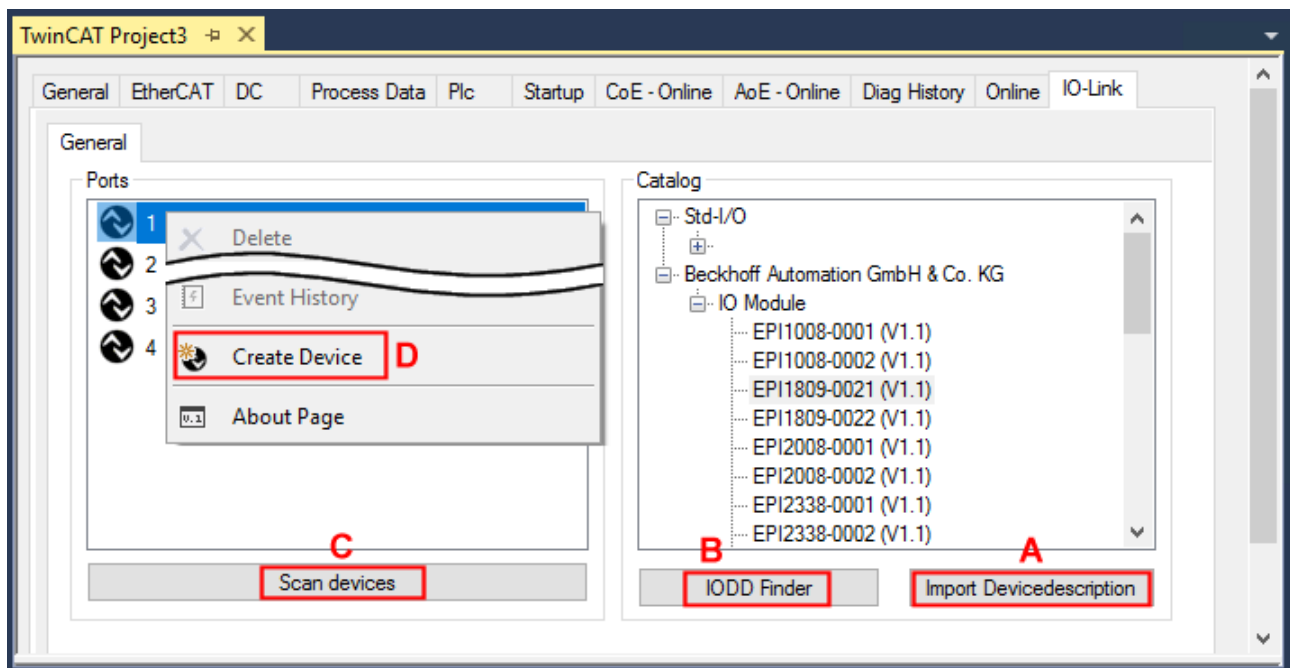

Fig. 10: Creating IO-Link devices

### 7.4.2.1 1. Importing the device description IODD

Importing the device description simplifies the integration of the IO-Link devices. The individual process data are broken down, enabling simple parameterization of the sensor. The IODD only needs to be imported during the initial commissioning of a new IO-Link device. The import is port-independent. Proceed as follows to import the IODD:

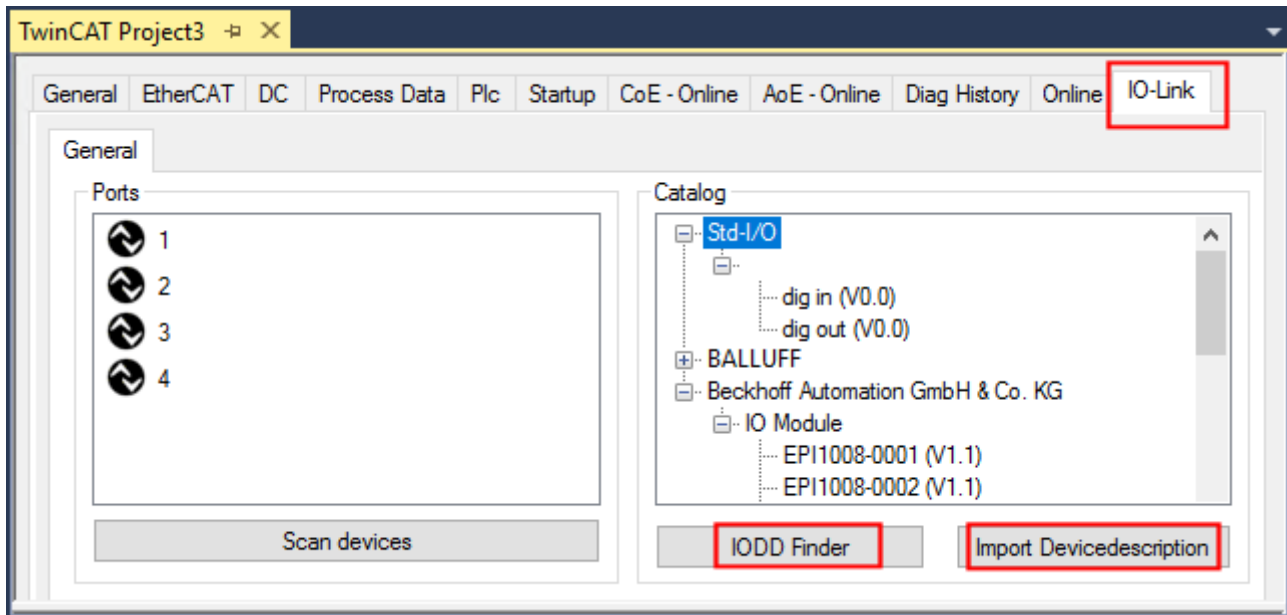

Fig. 11: Import of the IODD device description via “IODD Finder” or “Import Devicedescription”

#### Button “Import Devicedescription“

1. Press the “Import Devicedescription” button in the “IO-Link” tab
  2. Select the .xml file of the desired sensor.
  3. After pressing the Open button, the imported files are stored in the following folder:
    - for TwinCAT 2.x: \TwinCAT\IO\IOLink
    - for TwinCAT 3.x: \TwinCAT\3.X\Config\IO\IOLink.
- ⇒ The imported device descriptions are listed in a tree structure in the “Catalog” field, sorted by vendor.

#### **i** No manual copying of the XML files

Do not copy the files directly into the folder; read them in via *Import Devicedescription* instead! Important checks will otherwise be bypassed!

#### Button “IODD Finder“

1. Press the “IODD Finder” button in the “IO-Link” tab
2. Searching for the desired IO-Link sensor/device by entering them in the search mask; see the figure below (1)
3. Selecting the desired IO-Link sensor/device. Move the mouse pointer over the figure of the desired IO-Link sensor/device. A blue download icon appears, see the following figure (2).

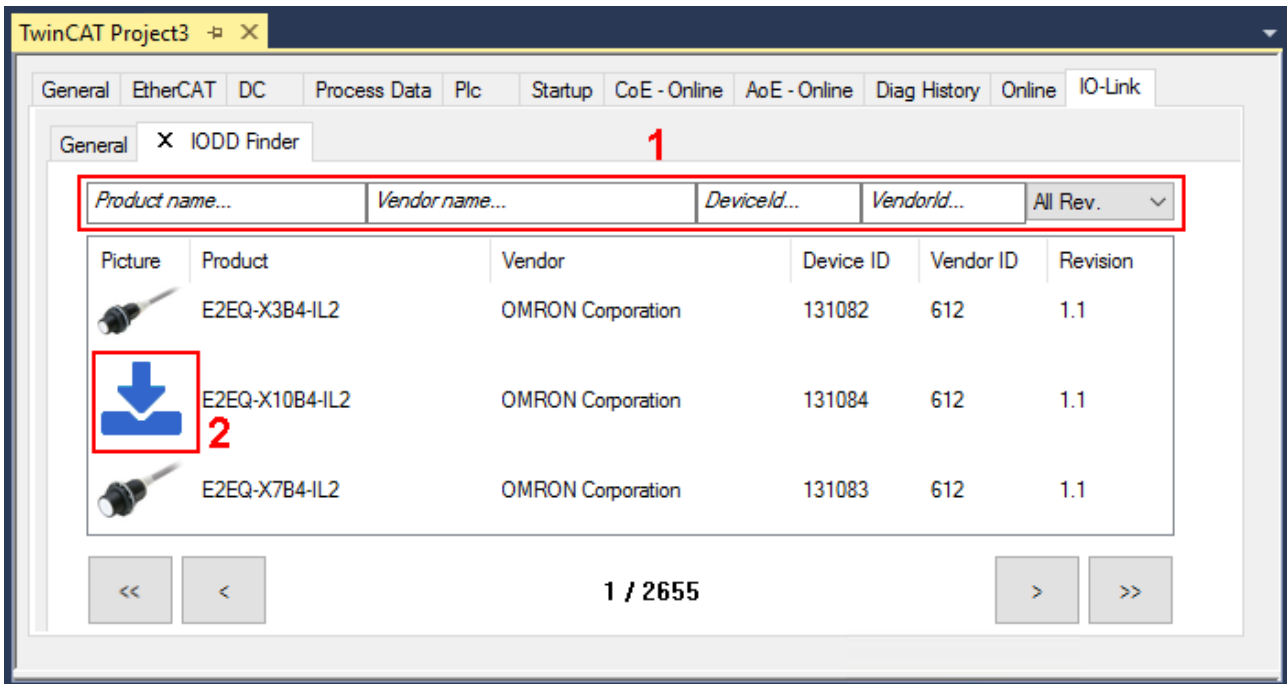

Fig. 12: IODD Finder, selection and import of the .xml-file

4. After clicking the download symbol, the .xml file of the selected IO-Link sensor/device is imported and stored in the following folder:
  - for TwinCAT 2.x: \TwinCAT\IO\IOLink
  - for TwinCAT 3.x: \TwinCAT\3.X\Config\IO\IOLink
5. When moving the mouse pointer over the IO-Link sensor/device, a green icon now indicates (see the following figure (3)) that the .xml file already exists.

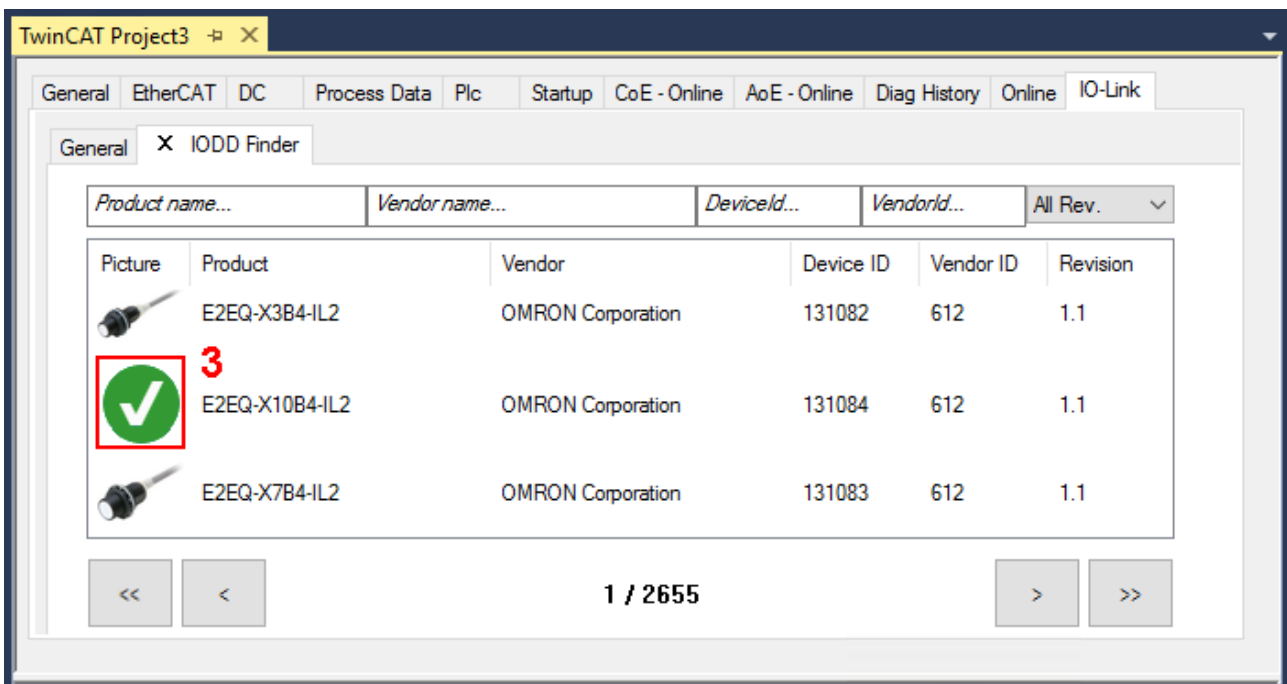

Fig. 13: IODD Finder, display of an already imported device description

- ⇒ The imported device descriptions are listed in a tree structure in the “Catalog” field of the IO-Link tab, sorted by vendor.

## 7.4.2.2 2. Assigning IO-Link device to port n

### Online configuration

✓ Requirement: The IO-Link device is connected.

1. Press the button Scan devices (see chapter [Automatic scanning](#) [▶ 59])

⇒ The device is automatically detected and created with the corresponding parameters. If several devices are stored in the IODD file, the first entry is always selected here. Grouping in the IODD is usually carried out by the vendor if the process data are the same and there are only mechanical differences (e.g. other material).

### Offline configuration

The *Catalog* field shows the IO-Link device catalog, which lists the already imported device descriptions in a tree structure, sorted by vendor.

1. Select the desired IO-Link device from the *Catalog* field
  - via drag and drop or
  - by right-clicking on the product with "Add to Port n".

### Activating the configuration

2. [Activate the IO link configuration](#) [▶ 65], so that changes become effective.

⇒ The IO-Link devices are displayed, and the process data are created. If an error is found when integrating the IO-Link device, e.g. wrong VendorID or no device connected, then this is indicated via the status of the port (object state Ch.n 0xF100:0n).

### Configuration of the IO-Link ports as digital in- or output

IO-Link ports can also be configured as digital inputs or digital outputs. This allows digital sensors and actuators having no IO-Link functionality to be connected to IO-Link ports.

1. Expand the "Std-I/O" tree node in the "Catalog" field.
  - ⇒ The operating modes "dig in" and "dig out" appear.
2. Configure the desired port. There are two ways to do this:
  - Drag-and-drop: pull "dig in" or "dig out" onto the port in the "Ports" field or
  - Right-click on "dig in" or "dig out" and click on "Add to Port n".

### Example of port assignment on the IO link master EL6224

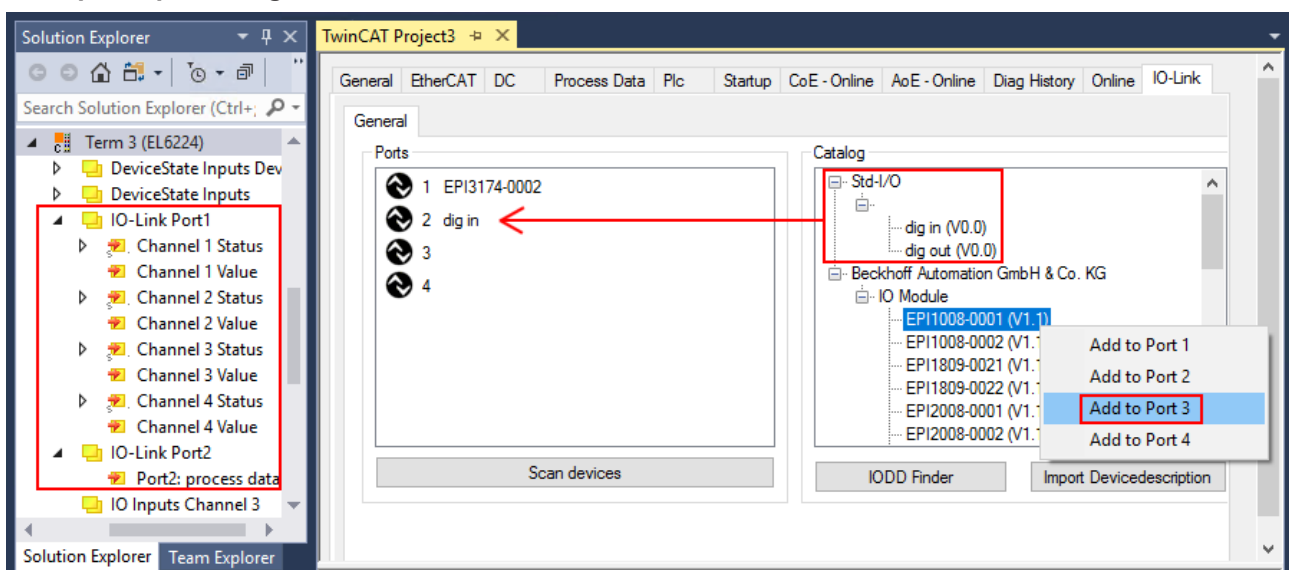

Port1:  
EPI3174-0002 is assigned  
Process data of Port1 and Port2 are displayed in the Solution Explorer.

Port2:  
is configured as digital input

Port3:  
EPI1008-0001 will be assigned

### 7.4.2.3 3. Automatic scanning of the IO-Link ports

This part of the documentation describes the configuration of the physically available IO-Link devices in TwinCAT.

During automatic scanning of the IO-Link ports, the steps “WakeUp pulse”, “Baud rate setting”, “Reading of the communication parameters”, plus “Parameter server” and “Cyclic data exchange”, if applicable, are performed, see [Establishing the IO-Link communication \[▶ 26\]](#). The corresponding IO-Link device must be connected to the IO-Link port for this.

The connected devices are automatically detected, configured and a search is performed for the associated IODD.

#### Finding connected IO-Link devices

✓ Requirement: the master and the devices are cabled and supplied with voltage.

1. Click on the “Scan devices” button (see the following figure).

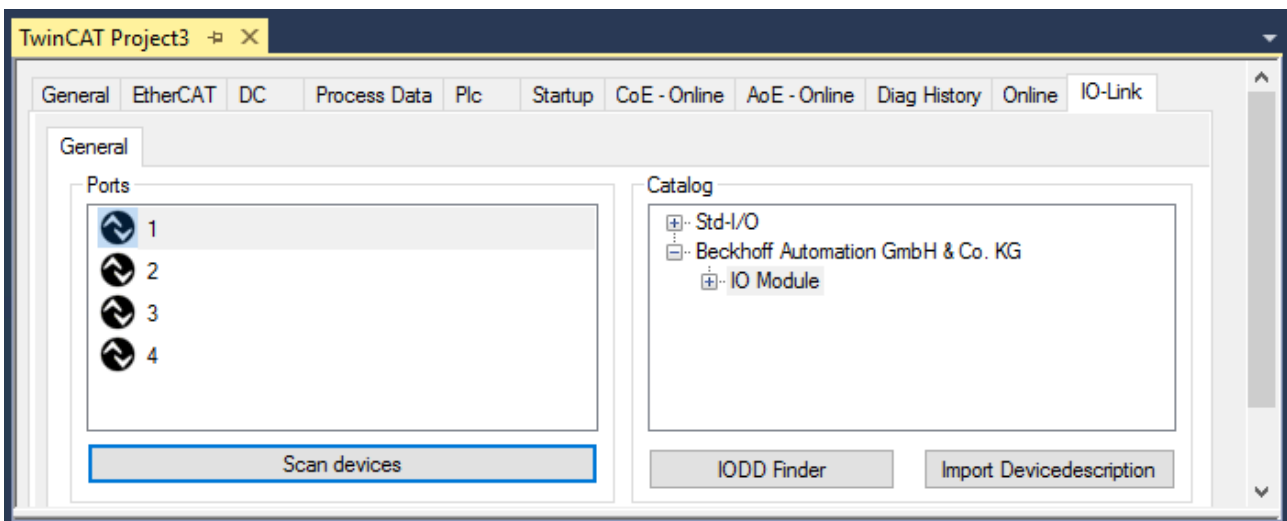

Fig. 14: Scan devices

- ⇒ The connected IO-Link devices can be found.
- ⇒ The information window lists the connected device for each of the four ports. Only port2 of the master is assigned an IO-Link device.
- ⇒ Confirm with the *OK* button.

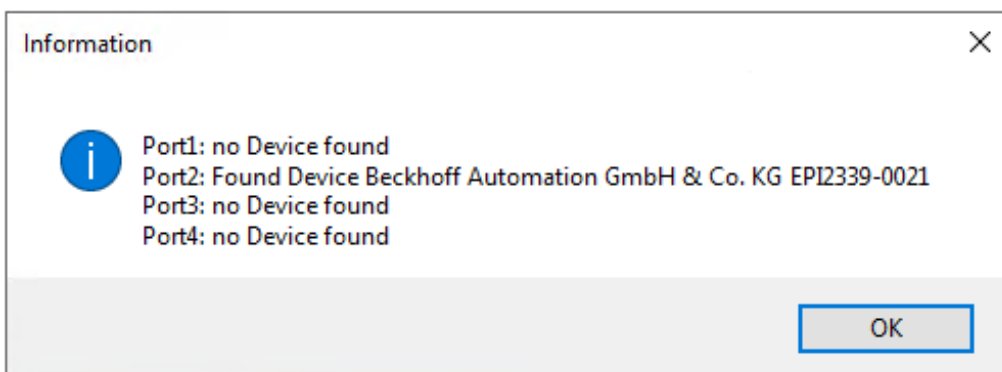



Fig. 15: Information “Scan devices”

1. To be able to work with the devices, the button “Reload Devices” must be clicked. 

The IO-Link devices are now entered in the *General* display. The Port2 “Details” field displays information about the connected device. Additionally the tabs Settings [▶ 61] and Parameter [▶ 62] can be opened.

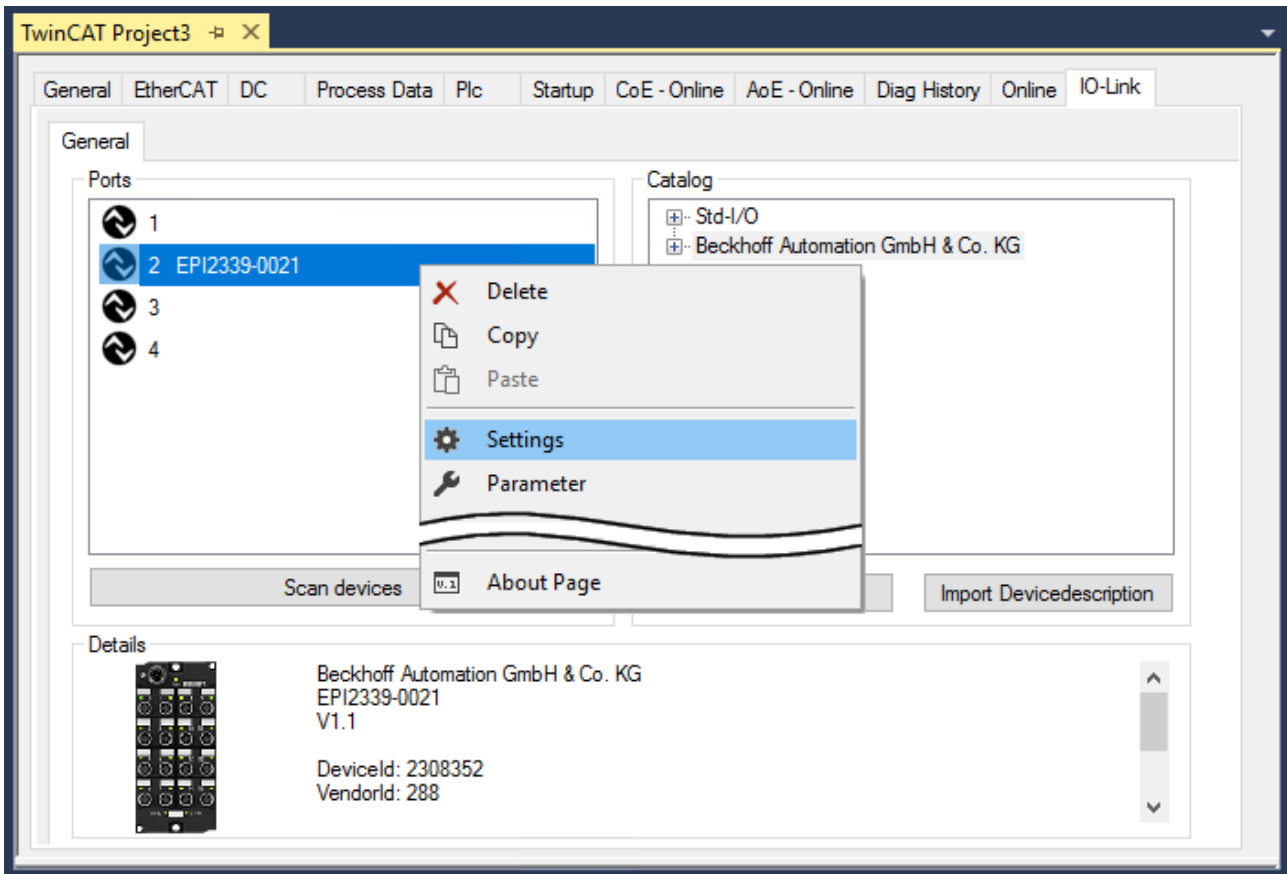

Fig. 16: Device at Port2, Display “Details”, open tabs “Settings” and “Parameter”

**Show settings of the device**

1. Right-click on port2, to display more details in dialog “Settings”.
2. If necessary, change the settings as described in chapter [Settings of the IO-Link devices \[► 66\]](#).

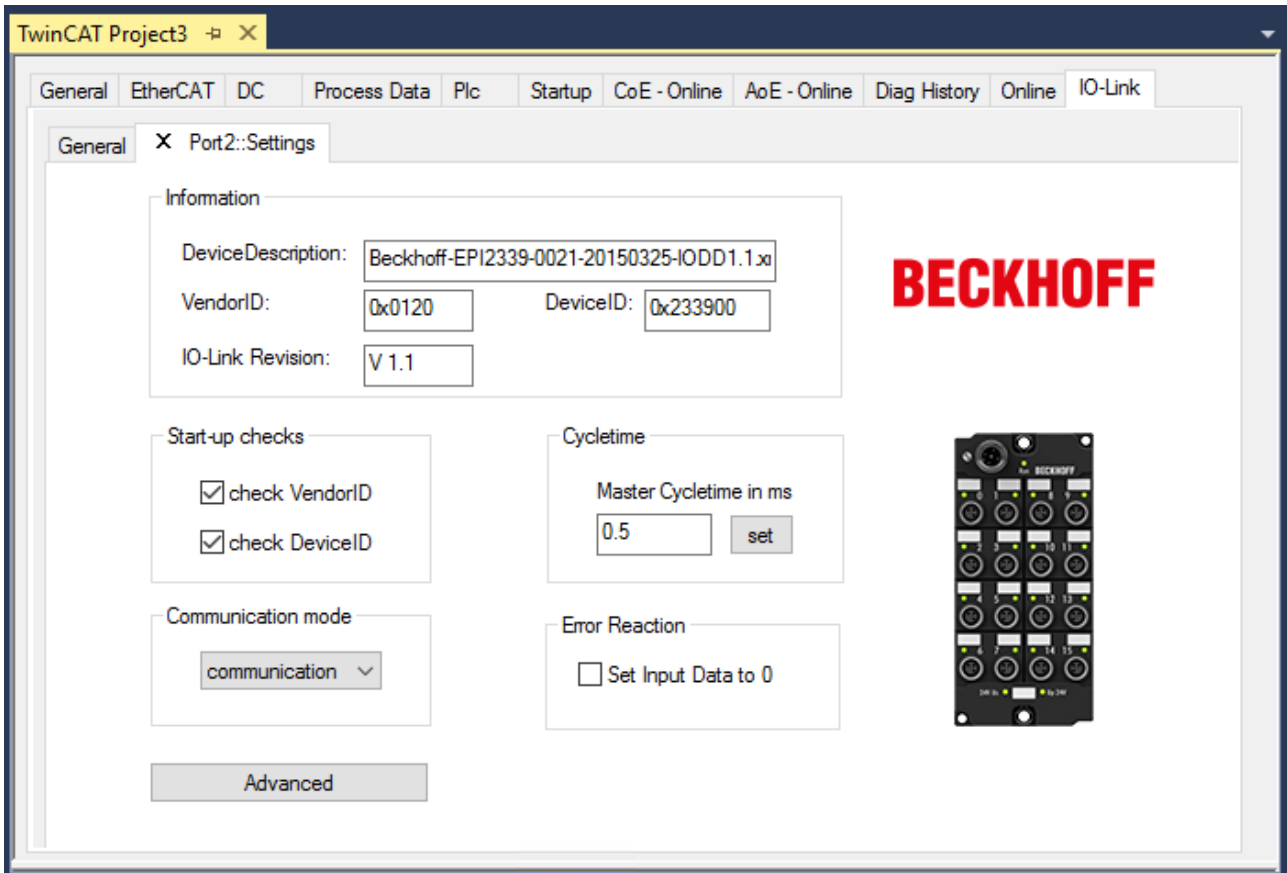

Fig. 17: Settings of the device assigned to port2

### Show parameters of the device

1. Open the Parameter tab via
  - double-click on Port2 or
  - right-click on Port2 and select "Parameter" in the menu.
 ⇒ The Parameters of of the respective IO link device are listed.
2. Parameterize the device as described in chapter [EPIxxxx, ERIxxxx - Setting of the IO-Link device parameters](#) [[▶ 68](#)].

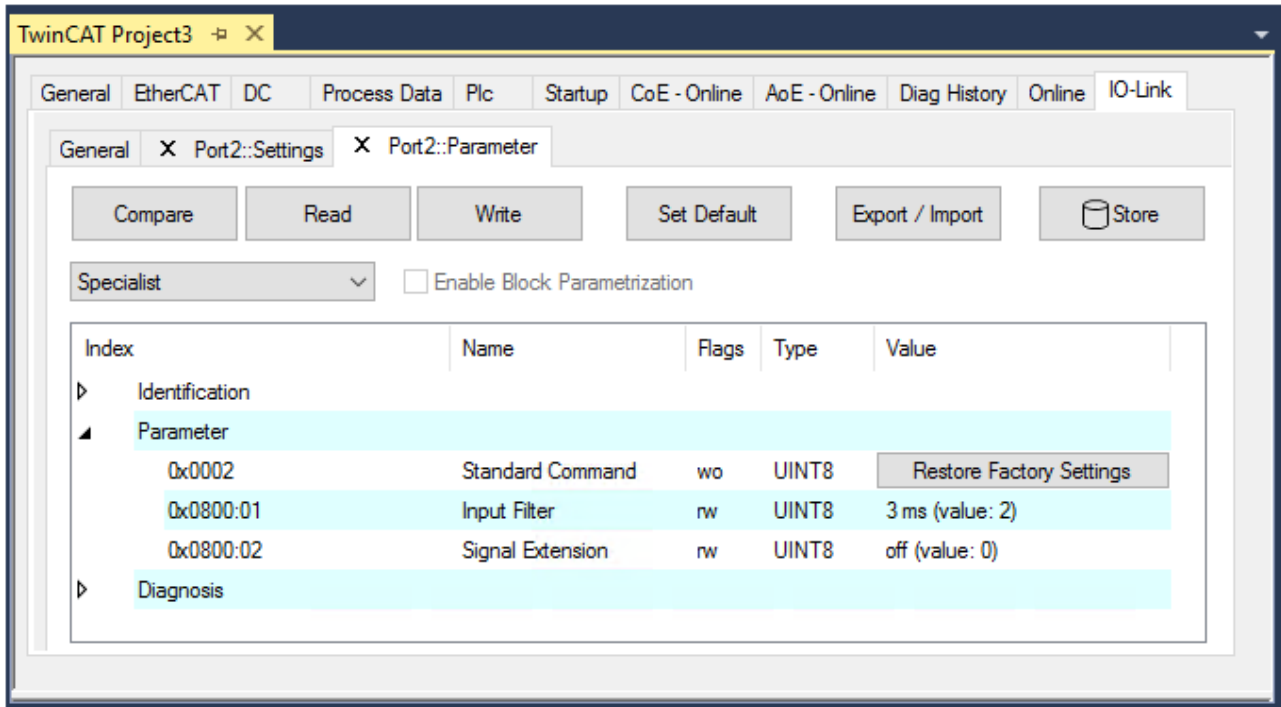

Fig. 18: Parameter of the device assigned to port2

### 7.4.2.4 4. Manual insertion via Create Device

This part of the documentation describes the manual configuration of the IO-Link devices in TwinCAT.

The manual insertion of the IO-Link device should only be carried out if the IODD from the vendor and the IO-Link device are not available. By saving the project, the settings for the individual ports are saved. The devices that were created are **not** stored in the "Catalog" (see the figure below (A)). To insert the IO-Link devices manually via "Create Device", proceed as follows:

1. The IODD of the IO link device is already available:  
Select the respective device from the "Catalog" field sorted by manufacturer (see following figure (A)).
2. No IODD is available:  
Add the device can be manually via "Create Device". These data are **not** saved in the "Catalog" field and must be manually entered for each port.
3. Right-click on the port to open the context menu (see the figure below (B)) and select "Create Device".
4. In the "Create Device" dialog an IO-Link device with the basic communication parameters can be created. The mandatory fields here are: For Vendor ID, Device ID and process data length see the figure below (C). The values VendorID and DeviceID can be entered both in hexadecimal notation (input format: 0xnnnn) and as decimal numbers (nnnn).  
The communication parameters to be entered can be found in the information provided by the device vendor.
5. If the IO-Link device version is 1.1, then the parameter server is activated by the selection of the check box "Revision V1.1" (see following figure (D)).
6. Activate the IO link configuration [▶ 65], so that changes become effective.

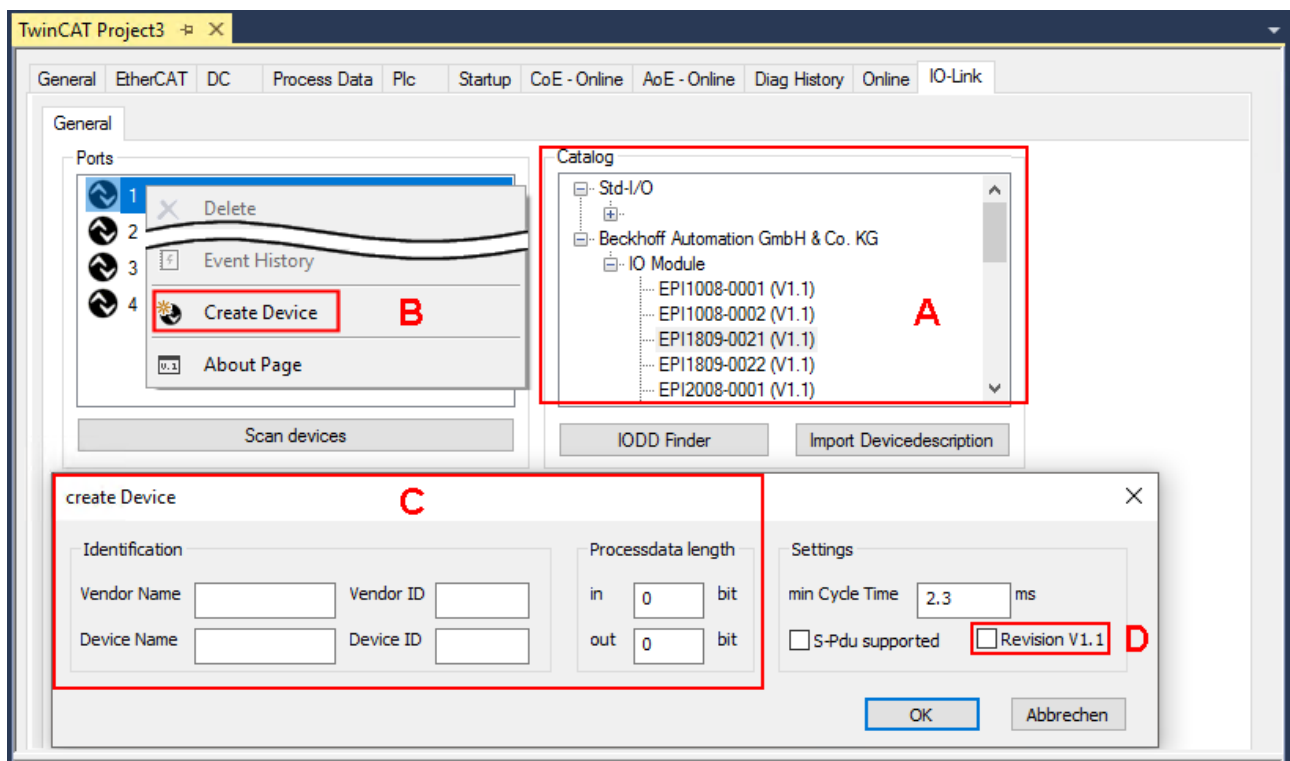

Fig. 19: Manual creation of an IO-Link device via the "Create Device" dialog (C)



#### Reading the IODD

Even when manually creating and scanning, the IODD should always be read in as well in order to display further sensor-specific information.

7. In the "Settings" tab of the IO link devices further settings can be made as described in chapter [Settings of the IO-Link devices \[▶ 66\]](#).

### 7.4.3 Removal of IO-Link devices

To remove a device that has already been inserted, proceed as follows.

1. Right-click on the port to open the context menu and select "Delete".

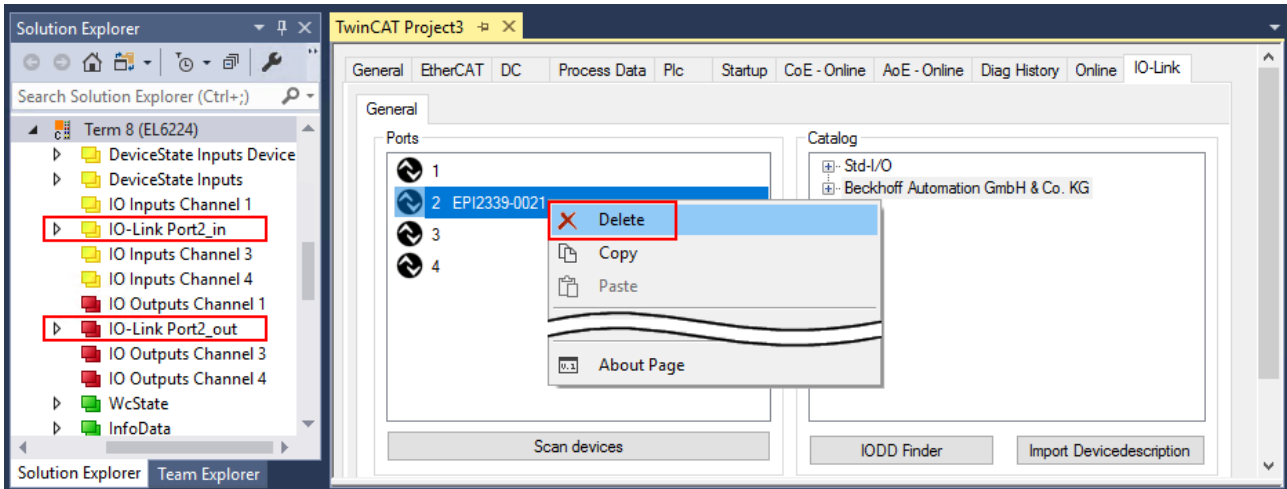

Fig. 20: Remove the device from port2

2. Activate the IO link configuration [▶ 65], so that changes become effective.  
⇒ The already create process data are removed.

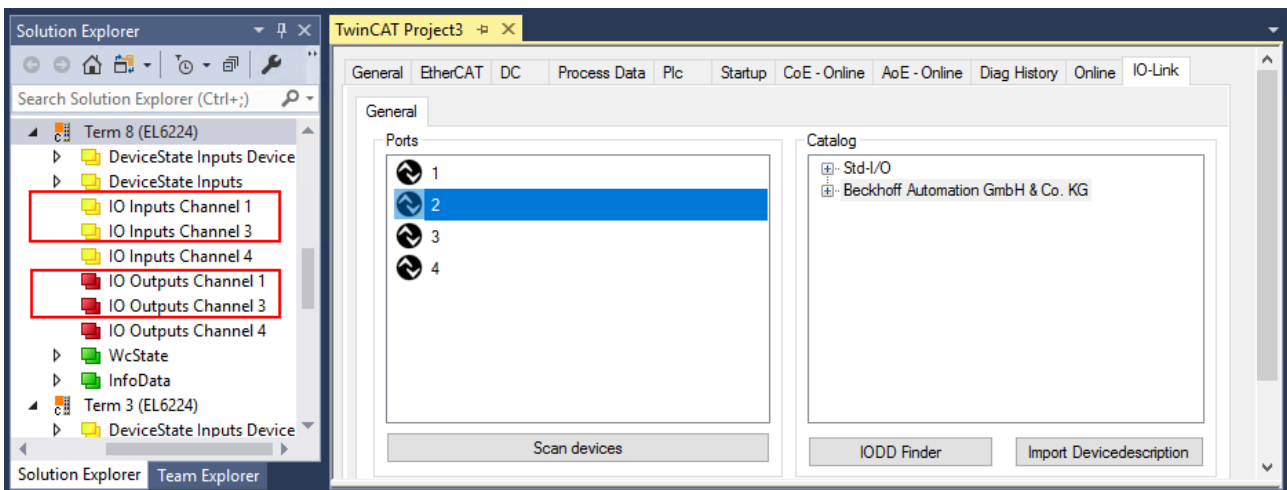

Fig. 21: The device was removed from the port2, the process data no longer displayed in the tree.

## 7.4.4 Activating the configuration

Changes in the IO-Link configuration tool only become effective when you activate the IO-Link configuration.

There are two ways to activate the IO-Link configuration:

- Click on the "Reload Devices" button



- Activate the TwinCAT configuration:  
Click on the "Activate Configuration" button



## 7.5 Settings of the IO-Link devices

To find the basic settings of the devices for each port, proceed as follows.

1. right-click on the port to open the context menu and select "Settings".
- ⇒ A new tab "Portx:: Settings" opens where the settings described below can be made.

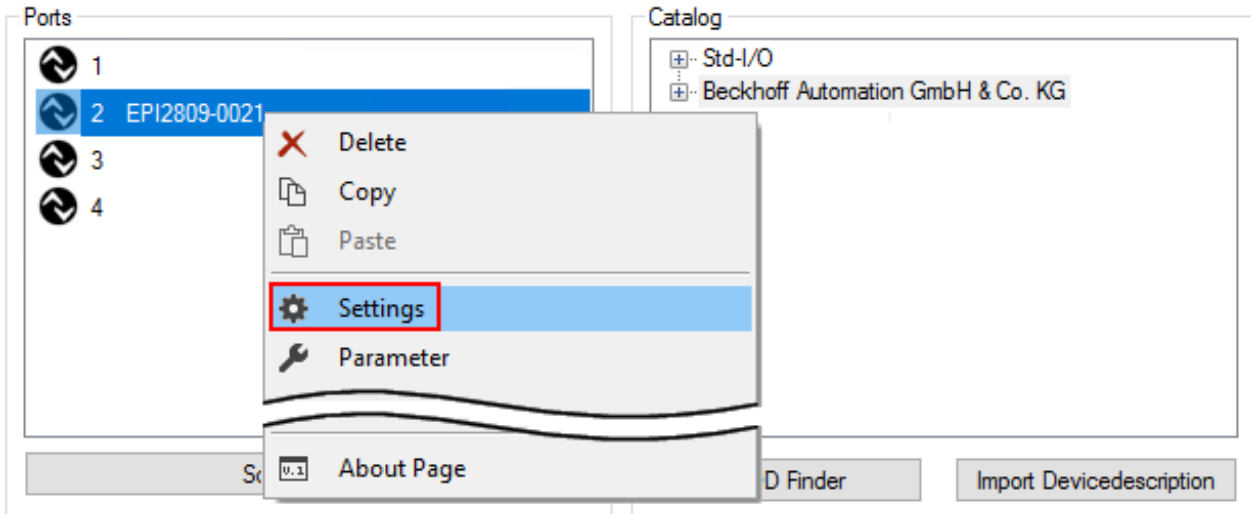

Fig. 22: Context menu - Settings

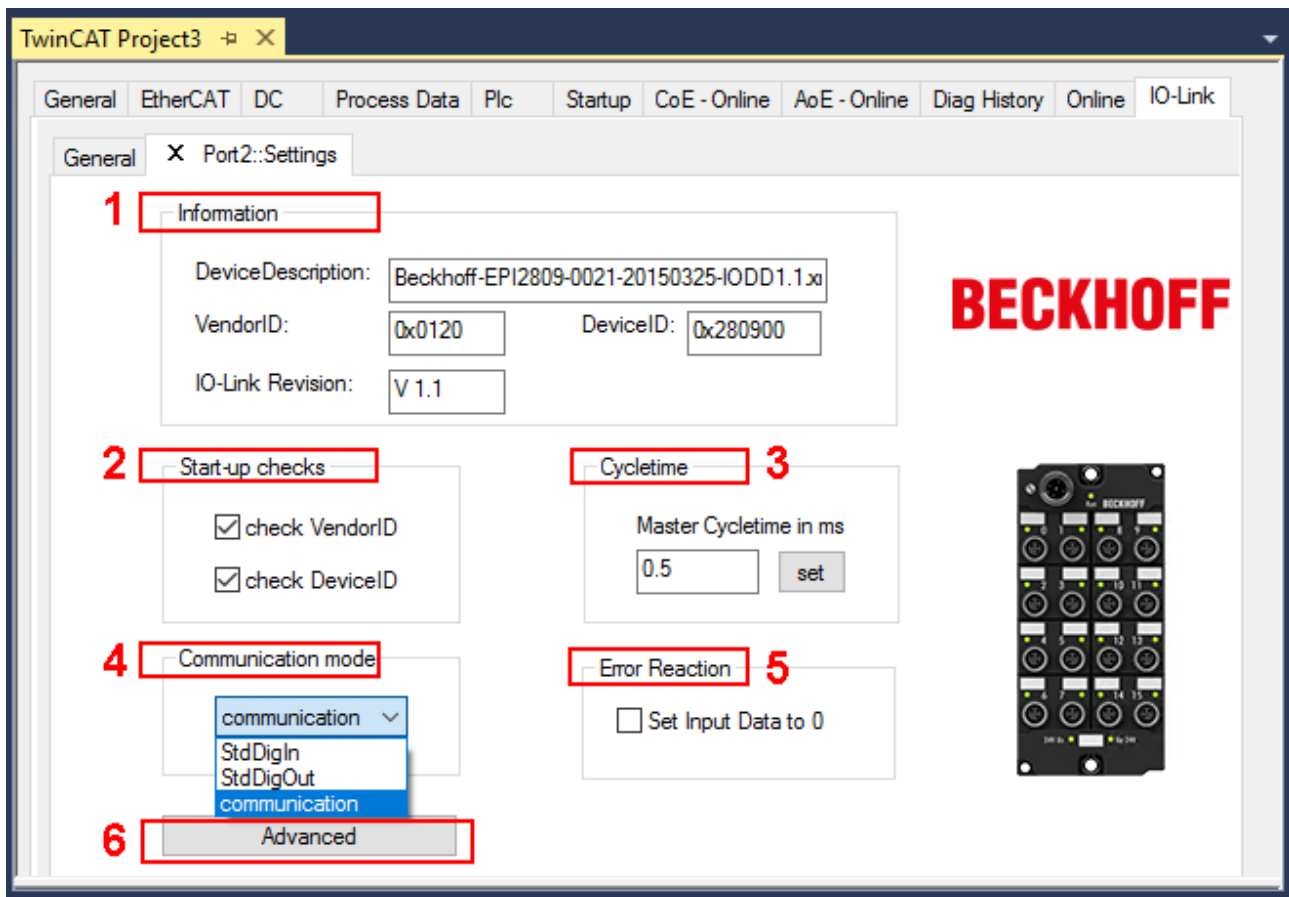

Fig. 23: Settings of the IO-Link devices

**1. Information**

This field is for information only; the IODD that was read in is displayed under Device Description. Furthermore, the VendorID, DeviceID and the IO-Link revision (V1.0 or V1.1) of the IO-Link devices are displayed. If the device is an IO-Link device V1.1, then the parameter server [[▶ 27](#)] function is supported.

The following settings can be made in the settings for the IO-Link devices (see figure above):

**2. Start-up checks**

This parameter can be used to specify that the Vendor ID and Device ID should be checked when the IO-Link device starts up.

⇒ This avoids errors when exchanging IO-Link devices.

**3. CycleTime**

Specifies the cycle time for the IO-Link master

**4. Communication mode**

Selection of the mode in which the IO-Link port is to be operated.

⇒ "Communication": Default mode for IO-Link devices

⇒ "StdDigIn / StdDigOut": Mode for non-IO-Link devices, automatically selected if the port is configured as a digital input or output [[▶ 58](#)].

**5. Error Reaction**

If the "Set Input Data to 0" field is activated:

⇒ input data are set to 0 in case of error

⇒ Status display: "Error"

**6. Button "Advanced"**

**7. Data Storage**

Pay attention to the sensor version:

⇒ V1.0 -> data storage is not supported

⇒ V1.1 -> data are stored in the parameter server (preset)

**8. Process Data Format**

Adaptation of the process data format

If Field "Use Octet String" is selected

⇒ complex data types (process data) are created as octet strings.

Advantage: simple further processing in the PLC

**9. Firmware Update of the Beckhoff IO-Link devices**

For a firmware update use the "Download" button.

Observe the description in the documentation of EPIxxx boxes in chapter Firmware Update des IO-Link Devices.

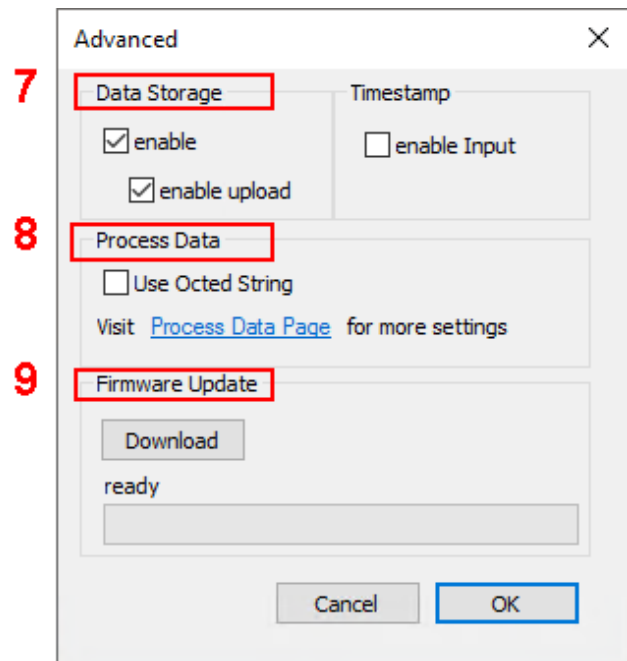

## 7.6 EPIxxxx, ERxxxx - Setting of the IO-Link device parameters

This chapter explains how to read out and set the IO-Link device parameters.

The number and type of the objects shown on the “Parameters” tab vary according to the type of sensor. The default settings as stored in the IODD can initially be seen.

To open the “Parameter” tab

1. Click the IO-Link master in the TwinCAT tree structure.
2. Click the “IO-Link” tab.
3. Select the port to which the IO-Link device is connected,
4. Double-click or by right-click to the port and select “Parameter”.

⇒ The “Parameter” tab is opened.

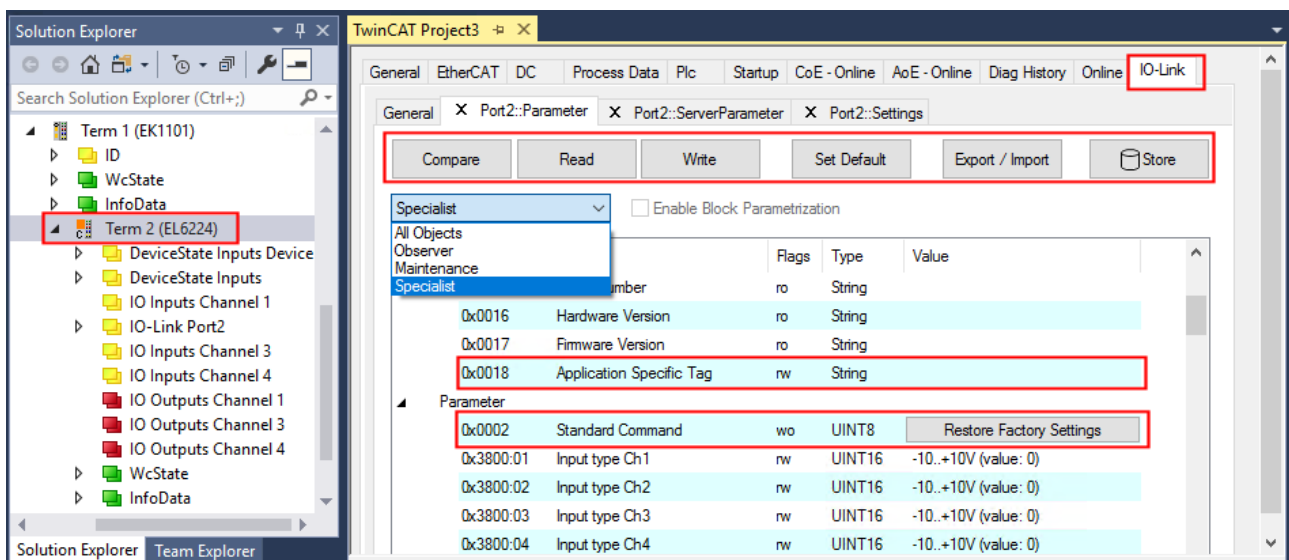
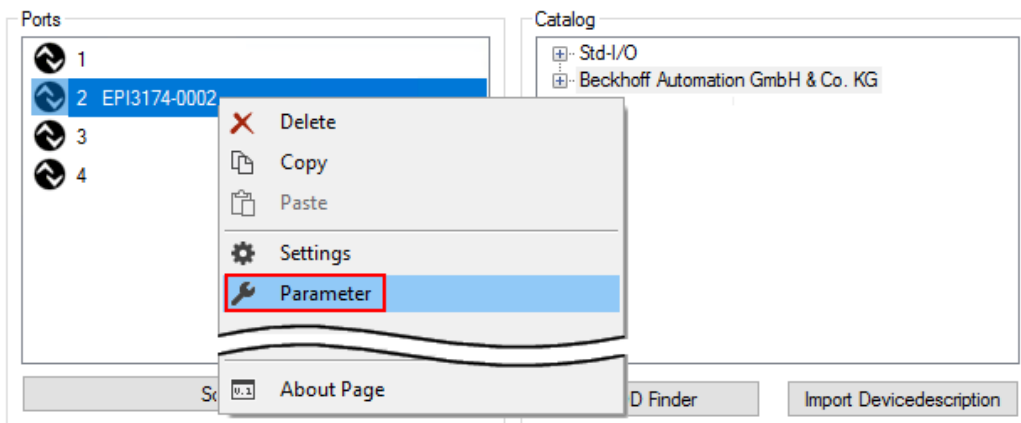

The device parameters are listed in the tab. The buttons [Compare](#) [▶ 69], [Read](#), [Write](#) [▶ 71], [Set Default](#) [▶ 72], [Export/Import](#) [▶ 73] and [Store](#) [▶ 74] are located at the top of the tab. The “Read”, “Write” and “Store” buttons are used to read out the parameters stored in the IO-Link device, load them and store them in the parameter server of the master.

Different user roles can be selected from the drop-down menu. The default user role is “Specialist”. The parameters are displayed in different representations and scopes.

Restarting the IO link device or restoring of the application parameters is possible via the parameter [Standard Command](#) [▶ 77].

Application specific information can be specified in parameter (0x0018) [Application Specific Tag](#) [▶ 78].

**“Compare” button**

1. Press the “Compare” button.
  - ⇒ the parameter data of the configuration are compared with the parameter sets in the sensor.
  - ⇒ The result is displayed in the “Parameter” tab see following figures.

**Conformity of configuration and sensor data**

The match is confirmed by a green tick in front of the index. Matching values are displayed in the “Value” field (see index 0x0018 “Application Specific Tag”).

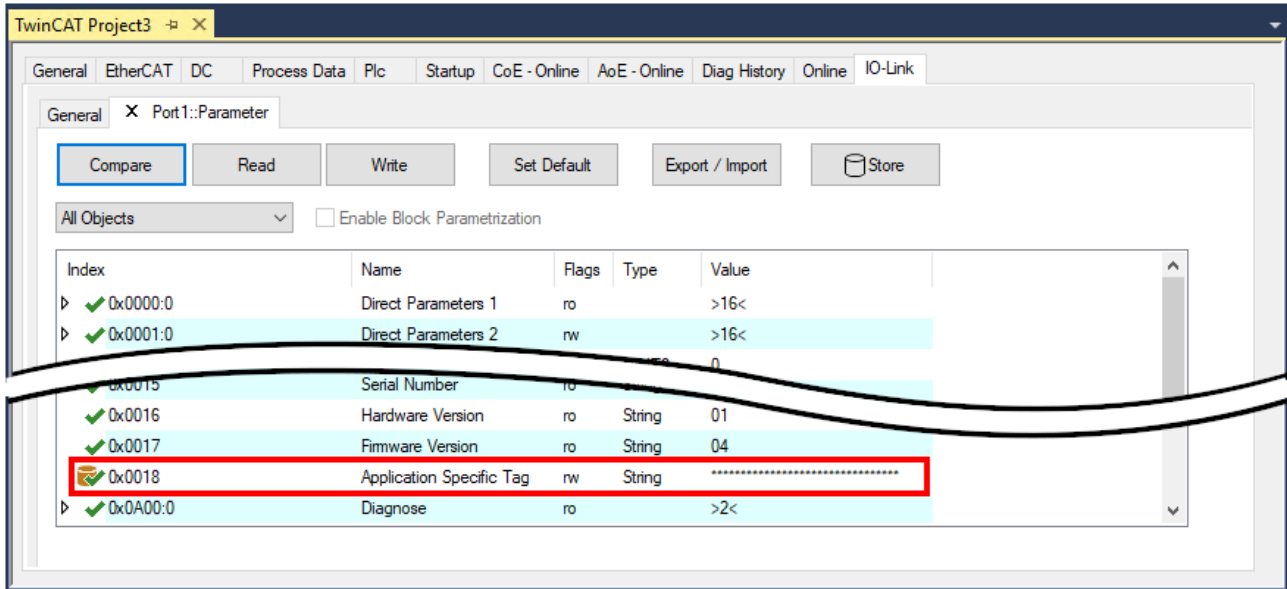

Fig. 24: Display of matching data in the “Parameter” tab

**Deviations between configuration and sensor data**

Deviations are indicated by a pen-symbol in front of the index. If there are different values in the “Value” field, the value “Compare” is displayed (see Index 0x0018 “Application Specific Tag”).

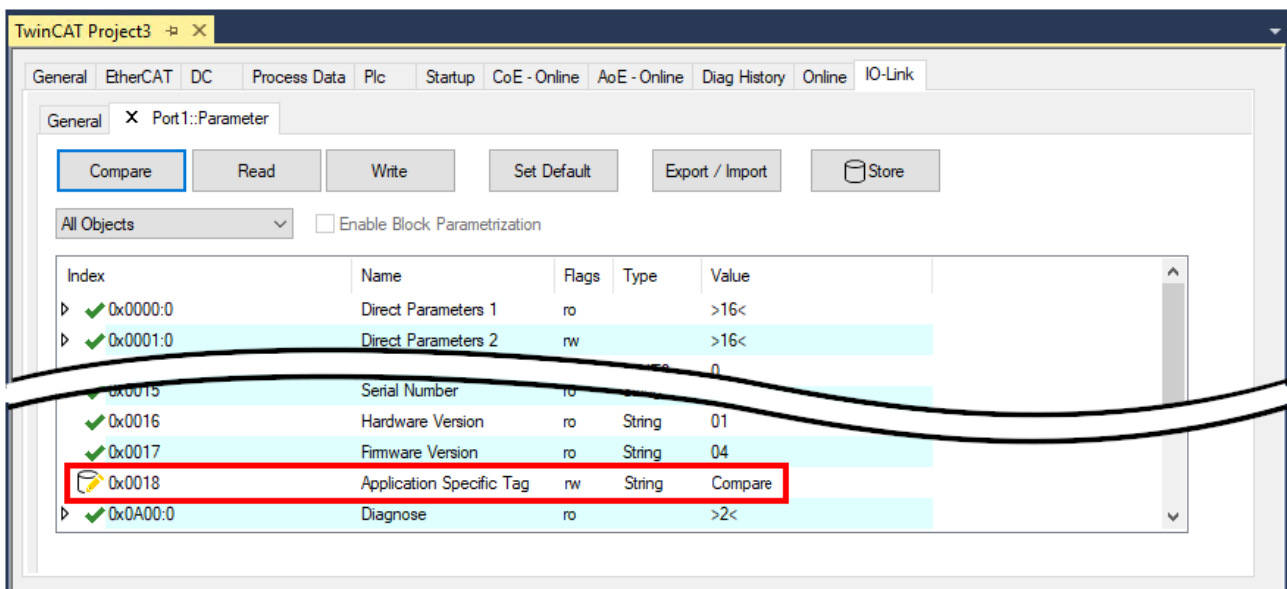

Fig. 25: Display of deviating data in the “Parameter” tab

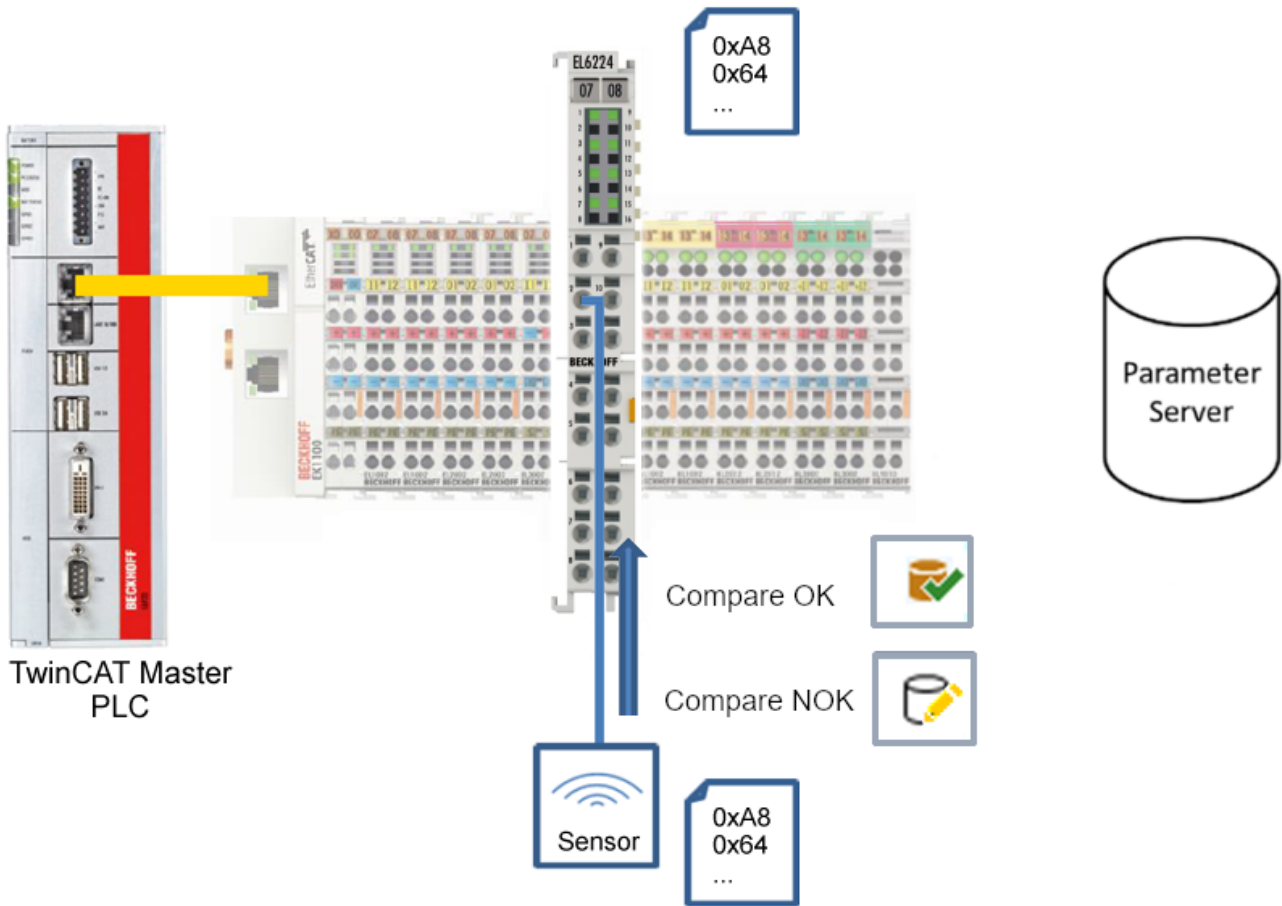

Fig. 26: Compare configuration and sensor data

**“Read” button**

The default values from the IODD file are always preset

1. Press the “Read” button
- ⇒ The current parameter values of the sensor are read. The successful reading of the data is confirmed with a green tick in front of the index.

**“Write” button**

The default values from the IODD file are always preset

1. Enter the desired value under “Value”.
2. Press the Enter key.
  - ⇒ The values are accepted.
3. Press the “Write” button.
  - ⇒ The data is written to the device (offline configuration is possible). The successful writing process is confirmed via a storing symbol in front of the index.

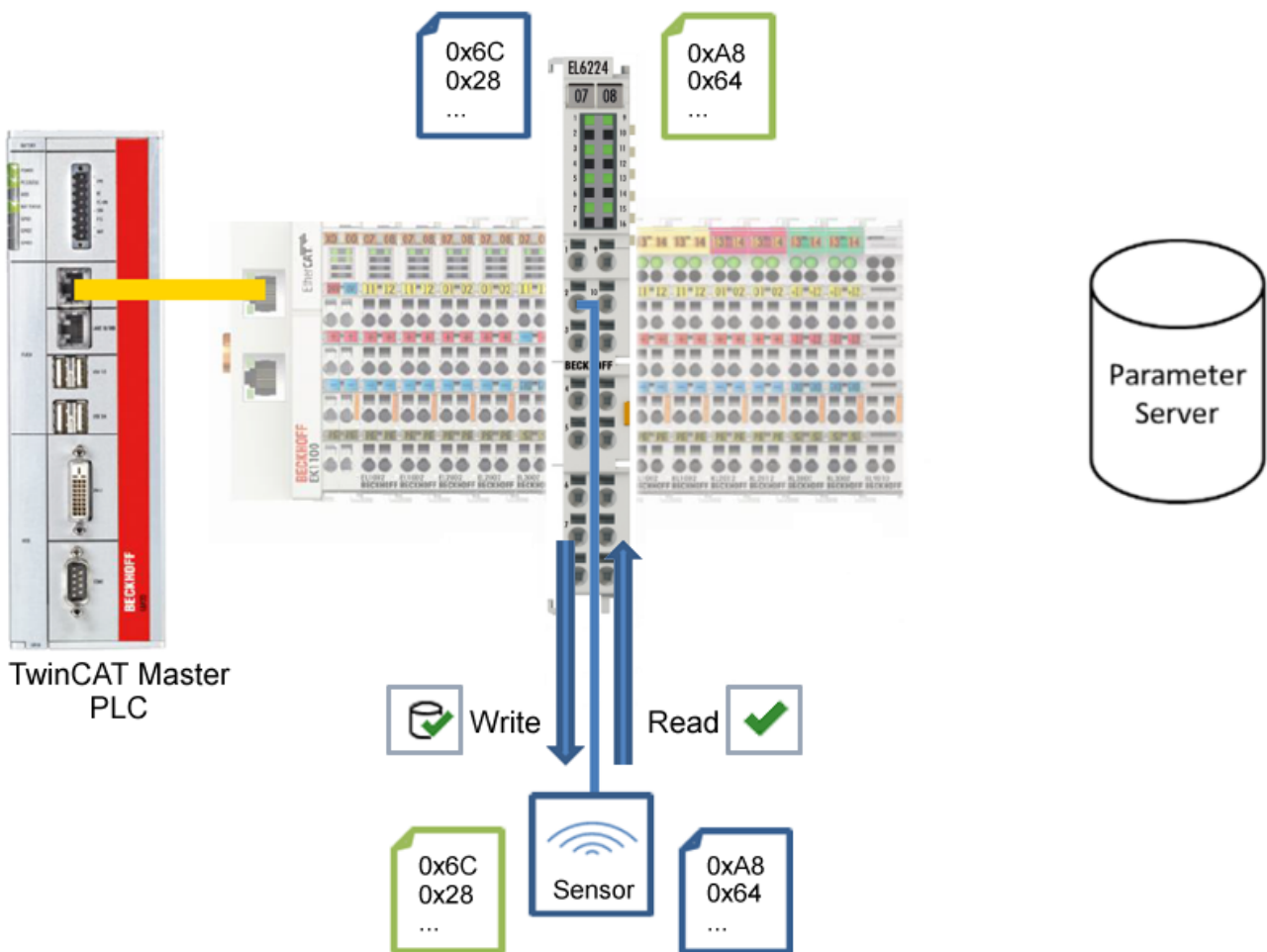

Fig. 27: Write parameter data to the sensor, read parameter data from the sensor.

**“Set Default” button**

1. Press the “Set Default” button.
- ⇒ All parameter values are set to the default settings.

**● Write default-values to the sensor**

**i** Note that the default-values must also be written to the device via the “Write” button.

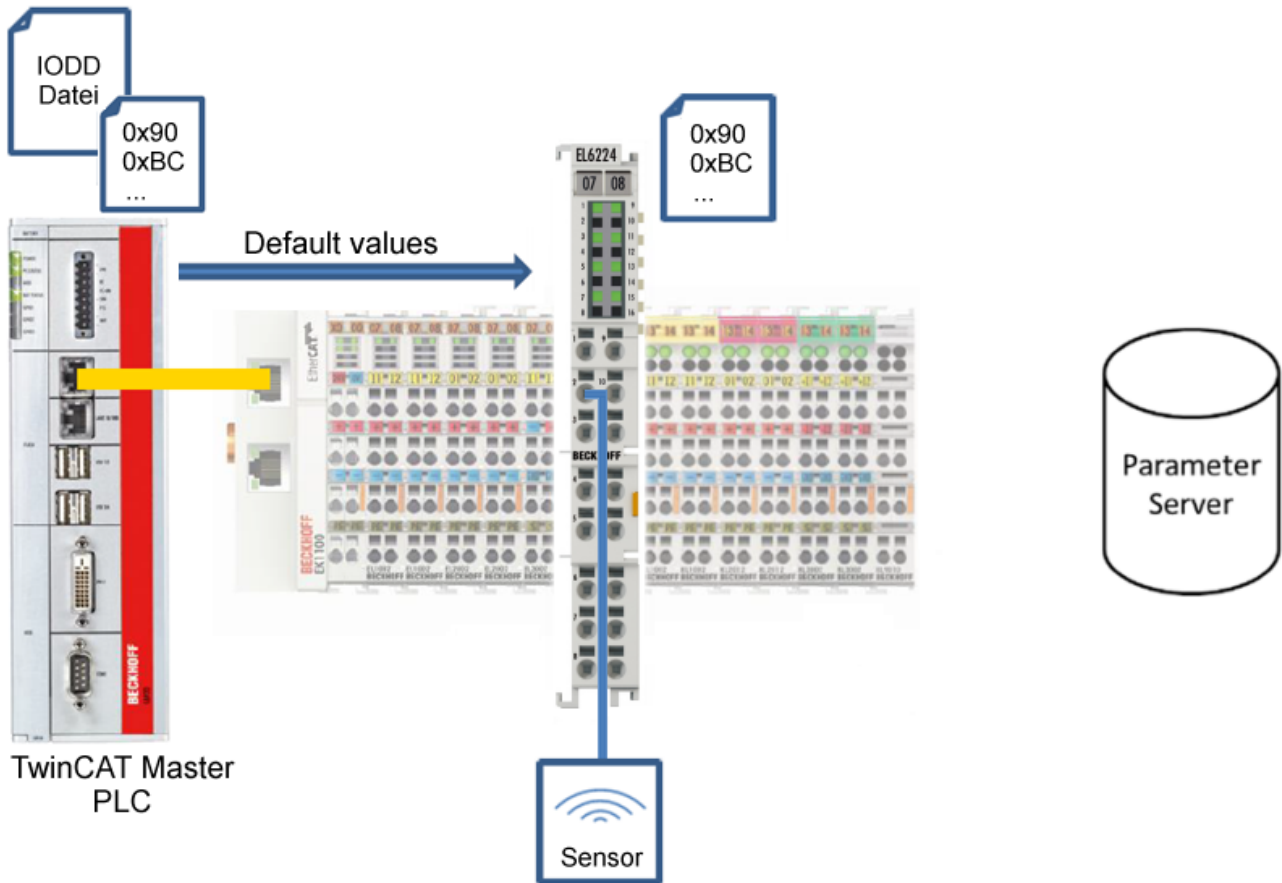

Fig. 28: Reset parameter values to default

**“Export / Import” button**

The set parameter values can be exported as a .vbs file and restored later via Import.

1. Press the “Export / Import” button (see the diagram below (1)).
  - ⇒ The Import / Export dialog is opened
2. Specify the path under which you want to export or import the .vbs file, see fig. (2) below and confirm with the “Open” button, see fig. (4) below.
3. In addition, the export options “Attach Store Command” and “Enable Block Parametrization” can be selected as shown in fig. (3) below.
  - ⇒ “Attach Store Command”: The parameters are loaded into the parameter server after the script has written all values.
  - ⇒ “Enable Block Parametrization”: Block parameterization is enabled. For some sensors, writing is only possible when block parameterization is enabled.
4. Press the “Export” or “Import” button
  - ⇒ The parameters are adopted from the imported file. The change of parameters is marked with a pencil symbol.
5. Write the new parameter values to the sensor via “Write” button.
  - ⇒ The data is written to the device (offline configuration is possible). The successful writing process is confirmed via a storing symbol in front of the index.

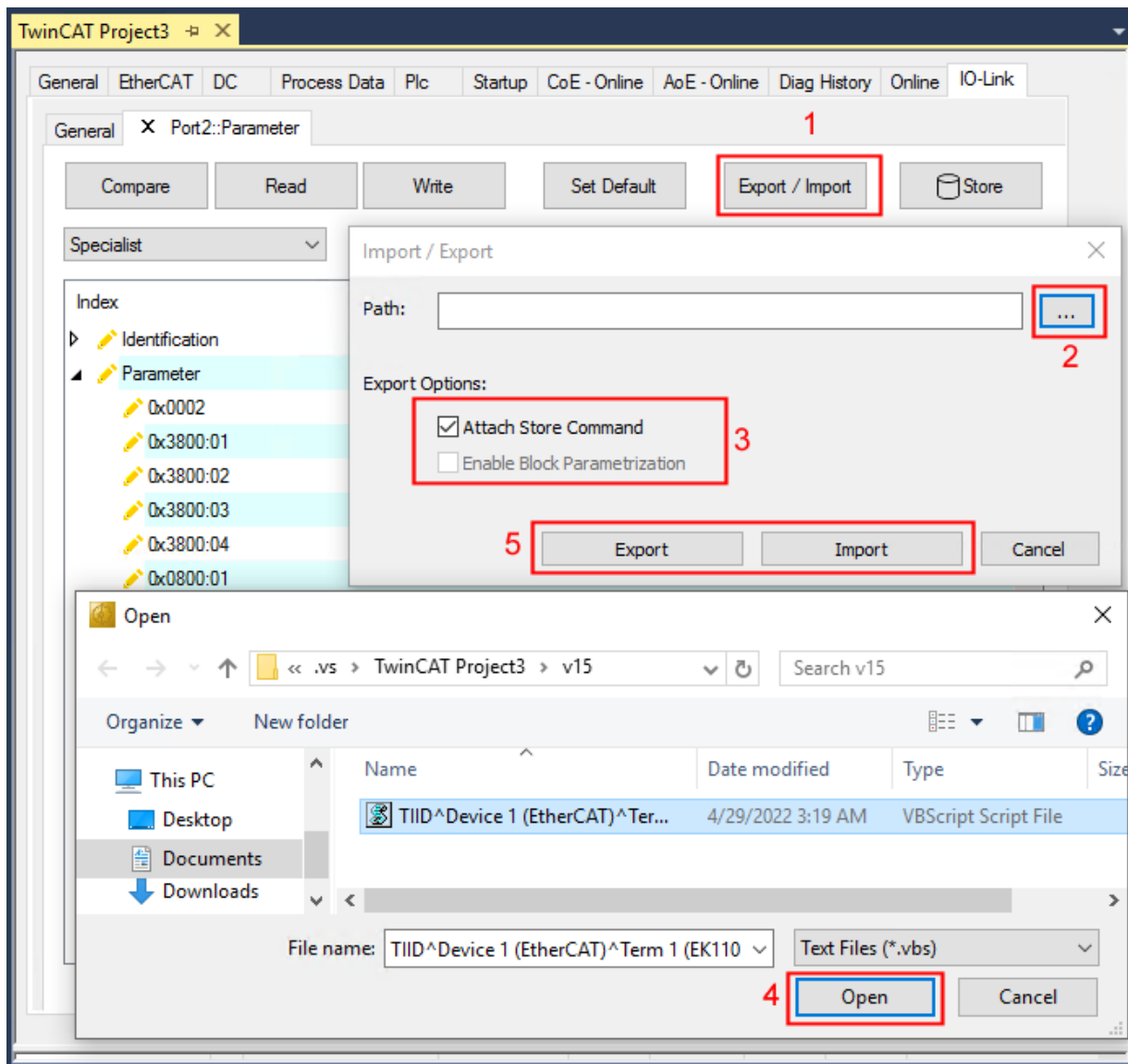

Fig. 29: Parameterization IO-Link device - Export / Import

**“Store” button**

1. Click “Store” (data storage):
  - ⇒ The Beckhoff IO-Link master stores sensor-dependent-data, e. g. the following parameters (0x0018) “Application-Specific Tag”, (0x08n0) “Settings” and 0x3800 “Range Settings”.  
The success of storing process is marked with the storing symbol.
  - ⇒ If the IO-Link device is exchanged for a similar module, the device can be restored.

The stored values are displayed in the “ServerParameter” tab

1. Right-click on the device and select “Parameter Server” from the menu.
- ⇒ The stored values are displayed.

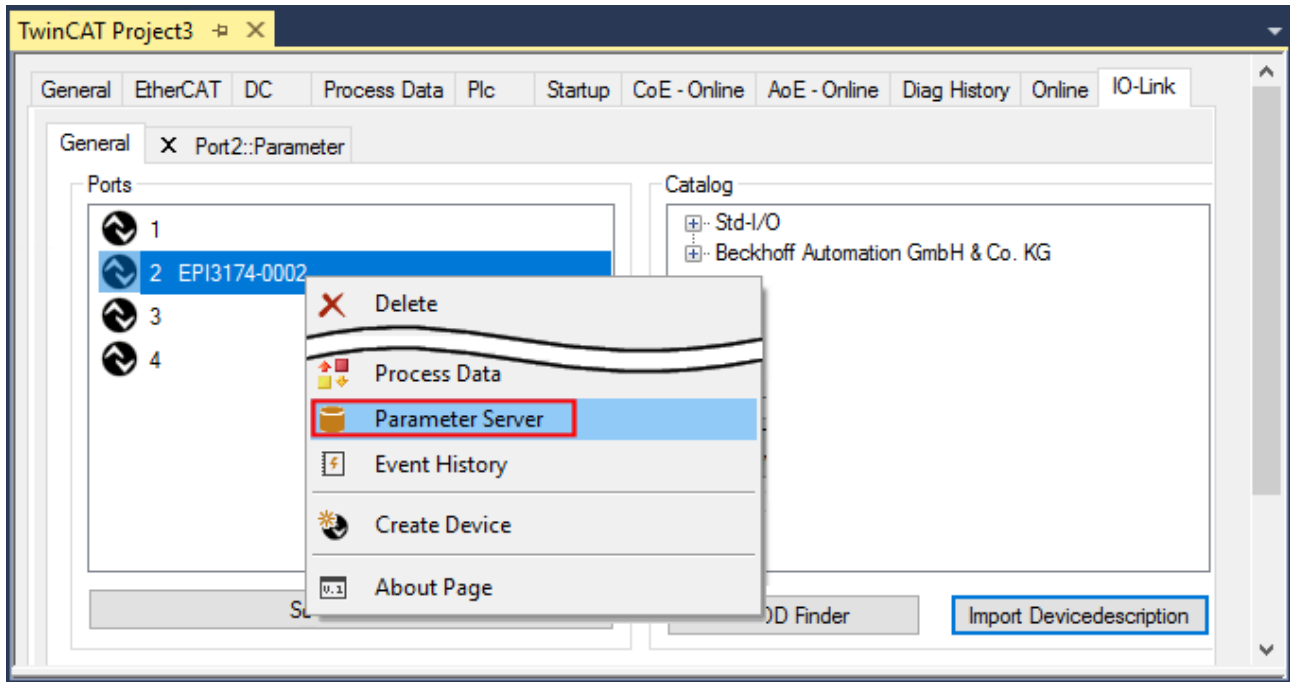

Fig. 30: Open the “ServerParameter” tab

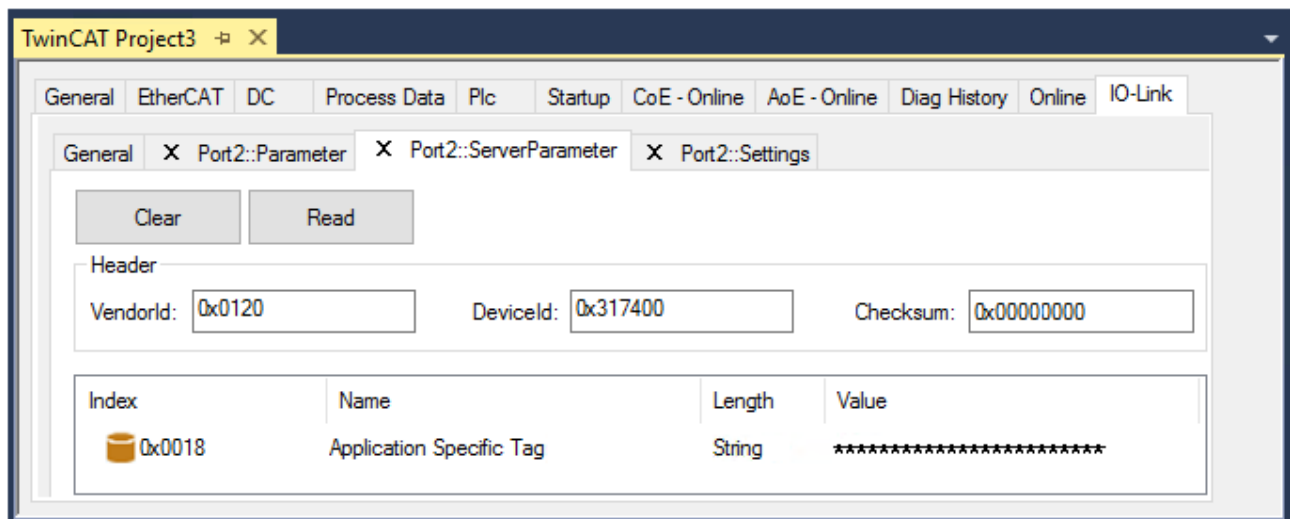

Fig. 31: „ServerParameter“ tab

**Activate store button via PLC**

As for CoE, the Indexgroup of an ADS command is specified as **0xF302** for the IO link data channel.

According to the IO-Link specification devices with ISDU support shall use index **0x0002** to receive the SystemCommand. The following list displays coding examples for system commands (ISDU), the complete table “Coding of SystemCommand (ISDU)” can be found in the [IO-Link specification](#).

Command (hex)	Command (dec)	Name of the command	Definition
....			
0x01	1	ParamUploadStart	Start Parameter Upload
0x02	2	ParamUploadEnd	Stop Parameter Upload
0x03	3	ParamDownloadStart	Start Parameter Download
0x04	4	ParamDownloadEnd	Stop Parameter Download
<b>0x05</b>	<b>5</b>	<b>ParamDownloadStore</b>	<b>Finalize parameterization and start Data Storage</b>
0x06	6	ParamBreak	Cancel all Param commands
....			

Use an ADS Write function block for activating the store-function via the plc. The following figure shows a sample code for activation of the store-Button (command 0x05 “ParamDownloadStore”)

```

Case_Write:
  AdsWrite_EL6224( WRITE := FALSE );
  AdsWrite_EL6224.IDXGRP   := EL6224_Ch_iGrp;
  AdsWrite_EL6224.IDXOFFS := EL6224_Ch_iOffWri;
  AdsWrite_EL6224.LEN     := SIZEOF(EL6224_bywrite);
  AdsWrite_EL6224.SRCADDR := ADR(EL6224_bywrite);
  AdsWrite_EL6224( Write := TRUE );
  eSwitch1 := Case_WriBu;

EL6224_AoePortCh : UINT := 16#1001;
EL6224_Ch_iGrp   : UDINT := 16#F302;
EL6224_Ch_iOffManu : UDINT := 16#00100000;
EL6224_Ch_iOffPro  : UDINT := 16#00140000;
EL6224_Ch_iOffWri  : UDINT := 16#00020000;
EL6224_sManu       : STRING;
EL6224_sPro        : STRING;
EL6224_bywrite     : BYTE := 16#5;
  
```

Fig. 32: Sample code for activation of the store-function via the plc

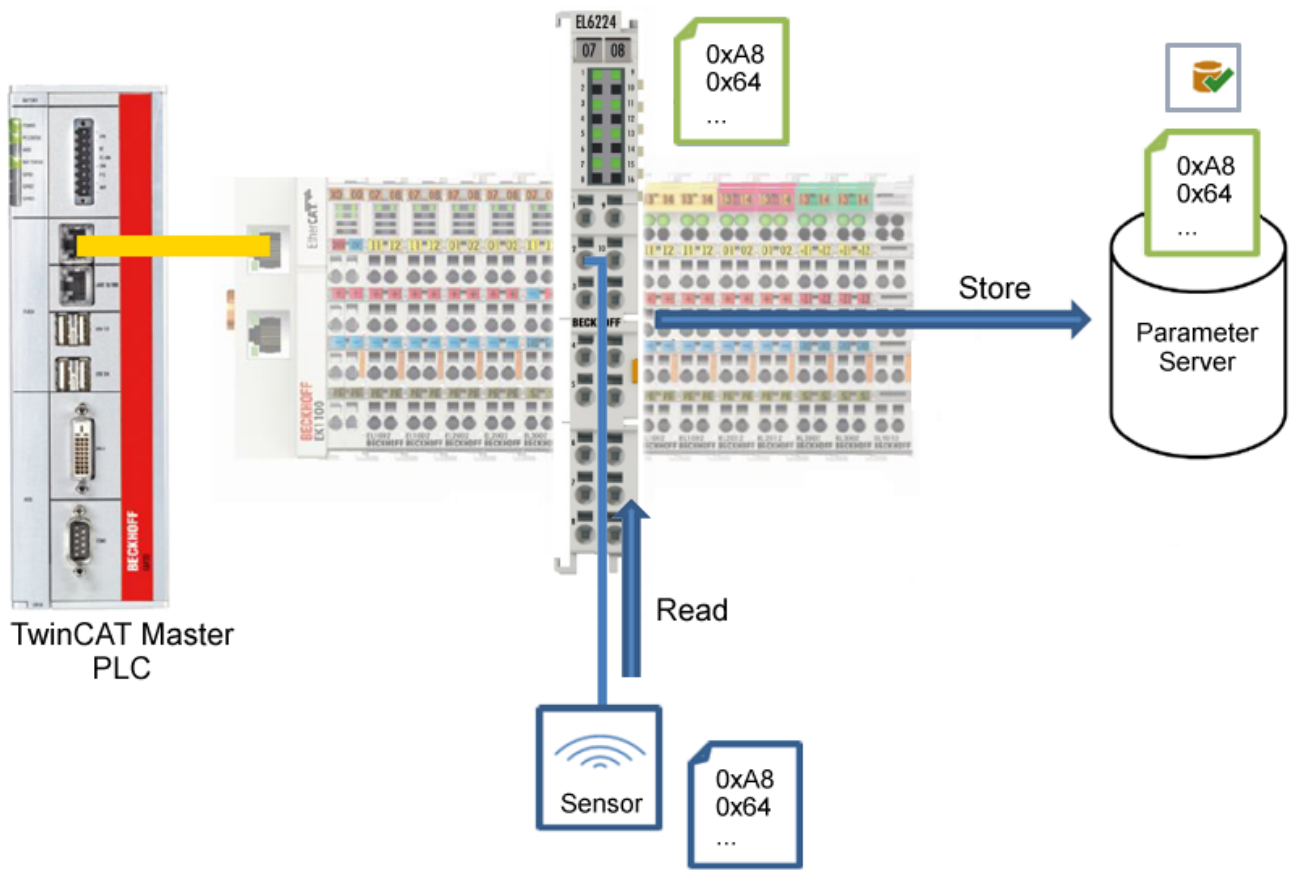

Fig. 33: Store parameters

**Standard Command (Index 0x0002)**

The IO-Link master writes various IO-Link-specific commands to the “Standard Command” during startup. Some of these commands are available in the TwinCAT interface (see figure below).

1. Click “Standard Command” in the parameter list of the “All Objects” user role, then double-click “Standard Command” in the right-hand field.
  2. Select the desired value from the list of different options and
    - “Device Reset”: Restarts the IO-Link device.
    - “Application Reset”: No function.
    - “Restore Factory Settings”: Restoring the application parameters, i.e. the Settings parameter (0x0800).
  3. Use the “Write” button (as described above [▶ 71]).
- ⇒ The data is written to the device (offline configuration is possible). The successful writing process is confirmed via a storing symbol in front of the index.

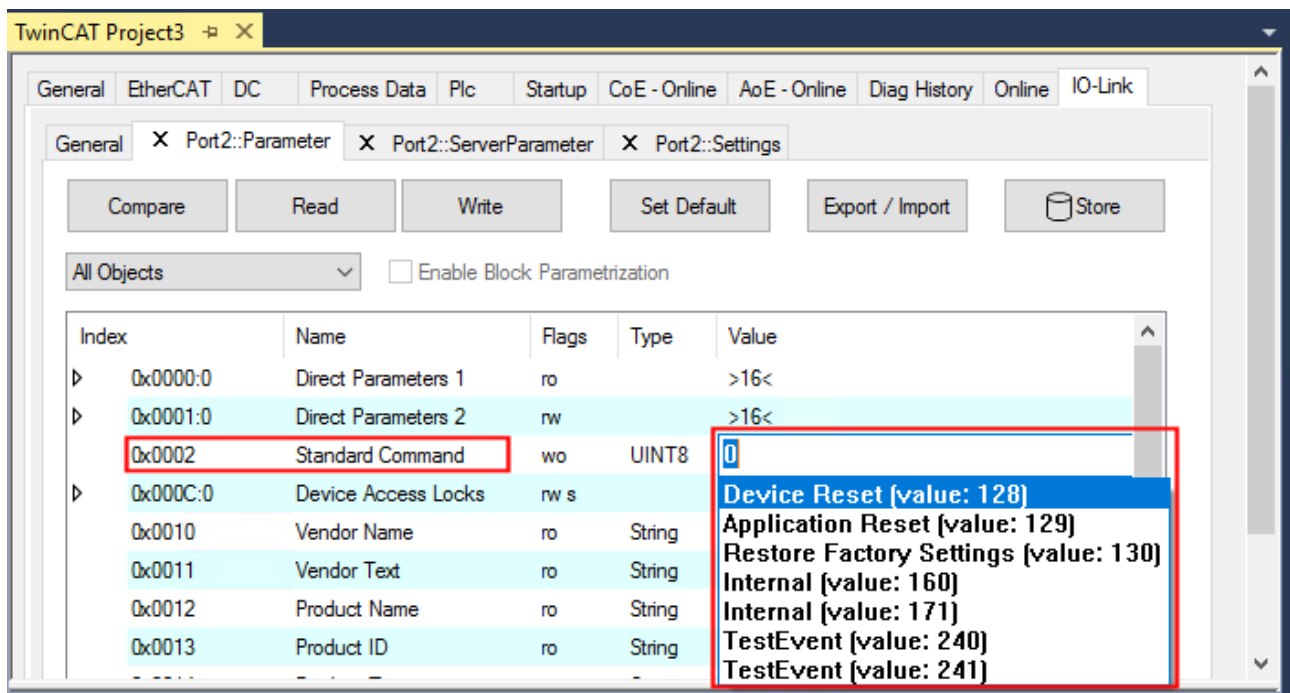

Fig. 34: Parameters IO-Link device “Standard Command”

**“Application Specific Tag” (Index 0x0018)**

Application-specific information can be entered and stored here.

1. Click “Application-Specific Tag” in the parameter list, then double-click “Application-Specific Tag” in the right-hand field.
2. Enter application-specific information and confirm with the Enter key.
3. Use the [Write \[▶ 71\]](#) button and the [Store \[▶ 74\]](#) button, if required (as described above).

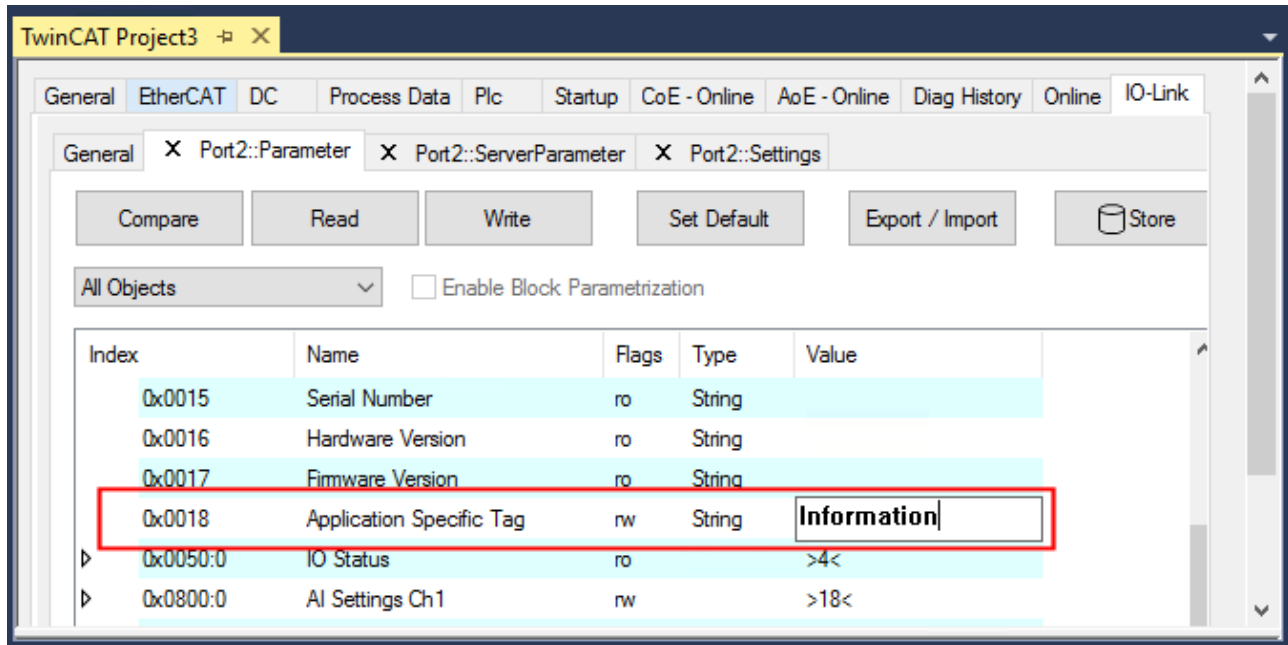

Fig. 35: Parameters IO-Link device: “Application Specific Tag”

## 7.7 Access to IO-Link data

### 7.7.1 IO-Link system communication

The EP622x IO-Link master is divided into two services. On the one hand it represents an IO-Link master in relation to the connected IO-Link devices, while on the other it is an EtherCAT slave in relation to the PLC TwinCAT master. The system communication is illustrated in Fig. *Illustration of the system communication of an EtherCAT master*.

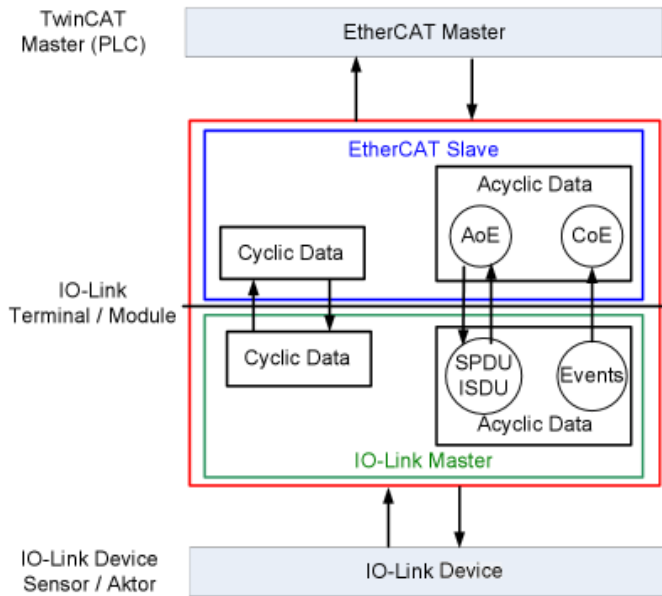

Fig. 36: Illustration of the system communication of an EtherCAT master

In principle cyclic and acyclic data are exchanged. The cyclic process data can be accessed via the PDOs, the acyclic data via [AoE \[► 81\]](#). The events are additionally displayed under [Diag History \[► 84\]](#) in the System Manager.

- **Cyclic data:**
  - Process data
  - Value status
- **Acyclic data:**
  - Device data
  - Events

## 7.7.2 PDO Assignment

The scope of the process data offered varies depending on the configured IO-Link ports. *DeviceState Inputs Device* and *DeviceState Inputs* are selected by default. Device-specific PDOs (*0x1A0n Port (n-1) Process Data*) are only displayed after configuring on the respective port and restarting the EtherCAT system or reloading the configuration in Config mode (F4); see Configuration of the IO-Link master.

Fig. 37: Illustration of the EP6224-2022 process data allocation, SM3 inputs

SM3, PDO Assignment 0x1C13			
Index	Size (byte.bit)	Name	PDO Content
0x1A05	2.0	DeviceState Inputs Device	Index 0xF101:0D - Device Diag Index 0xF101:10 - Device State
0x1A04	4.0	DeviceState Inputs	Index 0xF100:01 - State Ch1 Index 0xF100:02 - State Ch2 Index 0xF100:03 - State Ch3 Index 0xF100:04 - State Ch4
0x1A00	0.0 - 32.0	Port 1 Process Data	IO-Link device-specific / only active after configuration
0x1A01	0.0 - 32.0	Port 2 Process Data	IO-Link device-specific / only active after configuration
0x1A02	0.0 - 32.0	Port 3 Process Data	IO-Link device-specific / only active after configuration
0x1A03	0.0 - 32.0	Port 4 Process Data	IO-Link device-specific / only active after configuration

### **i** Process data representation

If data types are used that don't conform to IEC61131-3, they are represented as octed strings.

The state of the IO-Link ports 1 to 4 is displayed via index 0xF100:0n.  
The indices 0xF101:xx provide general diagnosis data.

Index	Size (byte.bit)	Name	Meaning
0xF101:0D	0.1	Device Diag	Occurrence of events (on the slave side) is reported via a status bit
0xF101:10	0.1	Device State	Interruption of communication with one of the slaves is reported via a status bit
0xF100:01	1.0	State Ch.1	0x_0 = Port disabled
0xF100:02	1.0	State Ch.2	0x_1 = Port in std dig in
0xF100:03	1.0	State Ch.3	0x_2 = Port in std dig out
0xF100:04	1.0	State Ch.4	0x_3 = Port in communication OP
			0x_4 = Port in communication COMSTOP / dig in Bit (only in the std. IO Mode)
			0x_8 = Process Data Invalid Bit
			0x1_ = Watchdog detected
			0x2_ = internal Error
			0x3_ = invalid Device ID
			0x4_ = invalid Vendor ID
			0x5_ = invalid IO-Link Version
			0x6_ = invalid Frame Capability
			0x7_ = invalid Cycle Time
			0x8_ = invalid PD in length
			0x9_ = invalid PD out length
			0xA_ = no Device detected
			0xB_ = error PreOP/Data storage (error in IO-Link State PreOP)

### 7.7.3 Accessing IO-Link parameters

The exchange of the acyclic data takes place via a specified index and subindex range that is device-specific and can be read about in the corresponding vendor documentation.

## 7.7.4 Parameter data exchange

An intelligent IO-Link sensor/actuator can support parameterization by ISDUs (Indexed Service Data Unit). The PLC must explicitly query or, when marked as such, send these acyclic service data.

### ● ISDU access

**i** TwinCAT supports access via ADS and via the CoE directory.

The respective parameter is addressed via the so-called ISDU index. The following ranges are available:

Designation	Index range
System	0x00..0x0F
Identification	0x10..0x1F
Diagnostic	0x20..0x2F
Communication	0x30..0x3F
Preferred Index	0x40..0xFE
Extended Index	0x0100..0x3FFF
	The range 0x4000 to 0xFFFF is reserved

The use and implementation of these ranges is the responsibility of the sensor/actuator manufacturer. For clarification, just a few of the possible indices are listed here. Please take a look at the relevant chapter "Object description and parameterization".

Index	Name
0010	Vendor Name
0011	Vendor Text
0012	Product Name
0013	Product ID
0015	Serial Number
0016	Hardware Revision
0017	Firmware Revision
...	...

### IO-Link operating modes

The IO-Link ports on the IO-Link master can be operated in the following nine modes (see Object description and parameterization - IO-Link State, Index 0xA0n0:01):

- INACTIVE: Statemachine is inactive
- DIGINPUT: The port behaves like a digital input
- DIGOUTPUT: The port behaves like a digital output
- ESTABLISHCOMM: The IO-Link wakeup sequence is running
- INITMASTER: Readout the IO-Link device and check the communication parameters
- INITDEVICE: Initialization of the IO-Link device
- PREOPERATE: Parameter server is running
- OPERATE: The port is used for IO-Link communication
- STOP: Communication is stopped (COM-stop)

### 7.7.5 ADS

Communication relating to IO link demand data is initiated via an ADS command. An ADS address always consists of a NetID and PortNo. TwinCAT relays ADS commands to the EP622x via AoE (ADS over EtherCAT), from where the command is relayed to the IO link master section and therefore the data channel.

#### AoE NetID

The EP622x is assigned a dedicated AoE-NetID for communication with the IO-Link master section. This is assigned by the configuration tool (Fig. Assignment AoE-NetID).

NetID at EP622x -> "EtherCAT"-> "Advanced Settings" -> "Mailbox" -> "AoE"

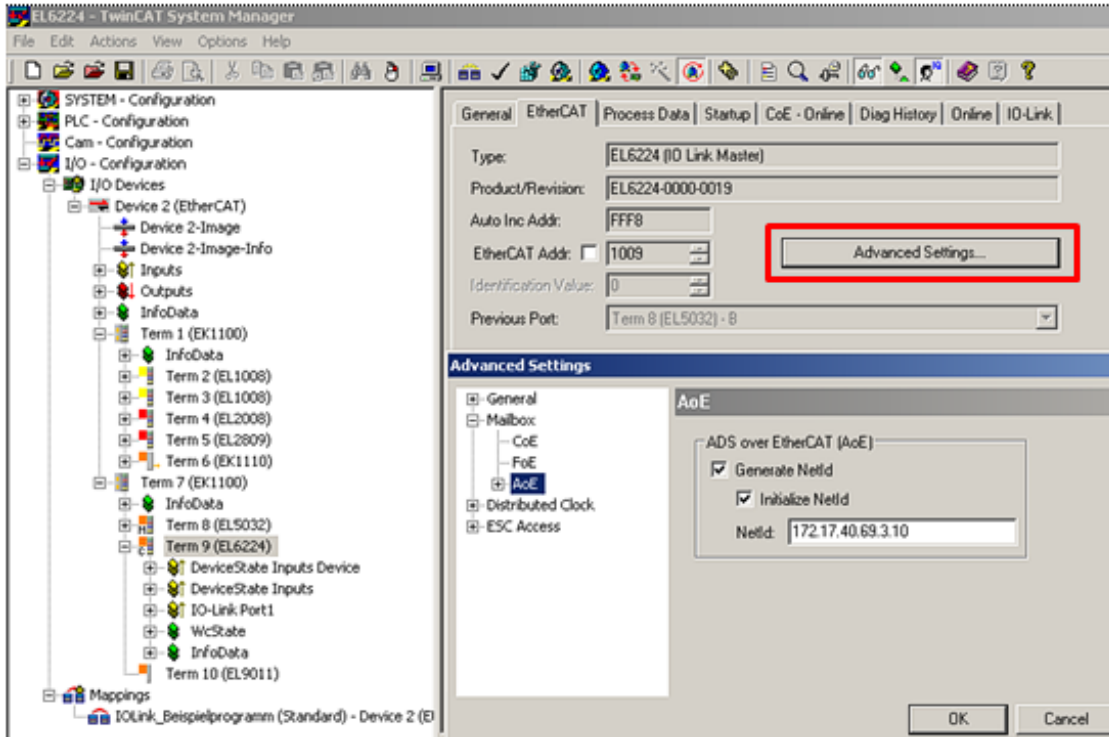

Fig. 38: AoE-NetID allocation

#### PortNo

The individual IO-Link ports for the master are allocated via the port number. The port numbers are allocated in ascending order from 0x1000. I.e. IO-Link Port1 corresponds to PortNo 0x1000 and IO-Link Portn corresponds to PortNo 0x1000 + n-1.

The following specification applies for the EP6224 (4-port IO-Link master):

- IO-Link Port1 corresponds to PortNo 0x1000
- IO-Link Port2 corresponds to PortNo 0x1001
- IO-Link Port3 corresponds to PortNo 0x1002
- IO-Link Port4 corresponds to PortNo 0x1003

#### ADS Indexgroup

As for CoE, the Indexgroup of an ADS command is specified as 0xF302 for the IO link data channel.

#### ADS Indexoffset

The IO link addressing with index and subindex is coded in the Indexoffset. The Indexoffset has a size of 4 bytes and is subdivided as follows: 2-byte index, 1-byte reserve, 1-byte subindex.

- Example: Indexoffset 0x12340056 corresponds to index 0x1234 and subindex 56

## 7.7.6 Access to events

Some of the IO-Link sensors forward events that occur to the master. These events may be items of information, warnings or error messages, e.g. short circuit or overheating.

The IO-Link master reports these events by setting the "Device Diag" bit. Further information on the events can be read via the CoE directory or the "Diag History" tab.

Type	Flags	Timestamp	Message
Warning	N	13.10.2014 10:11:18 433 ms	(0x0001) IO-Link Master Port 1: Eventqualifier = 0x00A4 (0xFFFF8CB0) Unknown TextId
Warning	N	13.10.2014 10:11:18 355 ms	(0x0001) IO-Link Master Port 1: Eventqualifier = 0x00E4 (0xFFFF8CB0) Unknown TextId
Error	N	13.10.2014 10:11:16 47 ms	(0x0001) IO-Link Master Port 1: Eventqualifier = 0x00B4 (0xFFFF8CB4) Unknown TextId
Error	N	13.10.2014 10:11:15 963 ms	(0x0001) IO-Link Master Port 1: Eventqualifier = 0x00F4 (0xFFFF8CB4) Unknown TextId
Error	N	13.10.2014 10:11:12 661 ms	(0x0001) IO-Link Master Port 1: Eventqualifier = 0x00B4 (0xFFFF8CB5) Unknown TextId
Error	N	13.10.2014 10:11:12 576 ms	(0x0001) IO-Link Master Port 1: Eventqualifier = 0x00F4 (0xFFFF8CB5) Unknown TextId
Warning	N	13.10.2014 10:11:07 500 ms	(0x0001) IO-Link Master Port 1: Eventqualifier = 0x00E4 (0xFFFF8CA4) Unknown TextId
Warning	N	13.10.2014 10:10:52 889 ms	(0x0001) IO-Link Master Port 1: Eventqualifier = 0x00A4 (0xFFFF8CB1) Unknown TextId
Warning	N	13.10.2014 10:10:52 811 ms	(0x0001) IO-Link Master Port 1: Eventqualifier = 0x00E4 (0xFFFF8CB1) Unknown TextId
Error	N	13.10.2014 10:10:51 758 ms	(0x0001) IO-Link Master Port 1: Eventqualifier = 0x00B4 (0xFFFF8CB4) Unknown TextId
Error	N	13.10.2014 10:10:51 673 ms	(0x0001) IO-Link Master Port 1: Eventqualifier = 0x00F4 (0xFFFF8CB4) Unknown TextId
Warning	N	13.10.2014 10:10:50 471 ms	(0x0001) IO-Link Master Port 1: Eventqualifier = 0x00A4 (0xFFFF8CA4) Unknown TextId
Warning	N	13.10.2014 10:10:50 393 ms	(0x0001) IO-Link Master Port 1: Eventqualifier = 0x00E4 (0xFFFF8CA4) Unknown TextId
Warning	N	13.10.2014 10:10:04 93 ms	(0x0001) IO-Link Master Port 1: Eventqualifier = 0x00A4 (0xFFFF8CB0) Unknown TextId
Warning	N	13.10.2014 10:10:04 9 ms	(0x0001) IO-Link Master Port 1: Eventqualifier = 0x00E4 (0xFFFF8CB0) Unknown TextId
Error	N	13.10.2014 10:10:01 194 ms	(0x0001) IO-Link Master Port 1: Eventqualifier = 0x00F4 (0xFFFF8CB5) Unknown TextId

Fig. 39: Diag History tab

The events are arranged according to type (information, warning, error), flag, occurrence of the event (time stamp) and message (port number and event code).

The meaning of the individual messages can be taken from the vendor documentation. The IO-Link device can be directly allocated on the basis of the port number. The events occurring can be managed using the various buttons.

- **Update History:** if the "Auto Update" field is not selected, then the current events can be displayed via the "Update History" button
- **Auto Update:** if this field is selected, then the list of events occurring is automatically updated
- **Only new Messages:** if this field is selected, then only those messages that have not yet been confirmed are displayed.
- **Ack. Messages:** an event that occurs is reported via the "Device Diag". Confirming the message will reset the bit to 0.
- **Export Diag History:** the events that have occurred can be exported as a "txt" file and thus archived.
- **Advanced:** this field currently (as at 3<sup>rd</sup> quarter 2015) has no function.

### **7.7.7 PLC library: Tc3\_IoLink**

The PLC library "Tc3\_IoLink" is used for communication with IoLink devices.

Function blocks are available for this purpose that support the "Common Profile" and "Smart Sensor Profile" and enable parameters to be read and written.

See software documentation in the Beckhoff Information System:

[TwinCAT 3 | PLC Library: Tc3\\_IoLink](#)

## 7.8 Restore the delivery state

You can restore the delivery state of the backup objects as follows:

1. Ensure that TwinCAT is running in Config mode.
2. In CoE object 1011:0 "Restore default parameters" select parameter 1011:01 "Subindex 001".

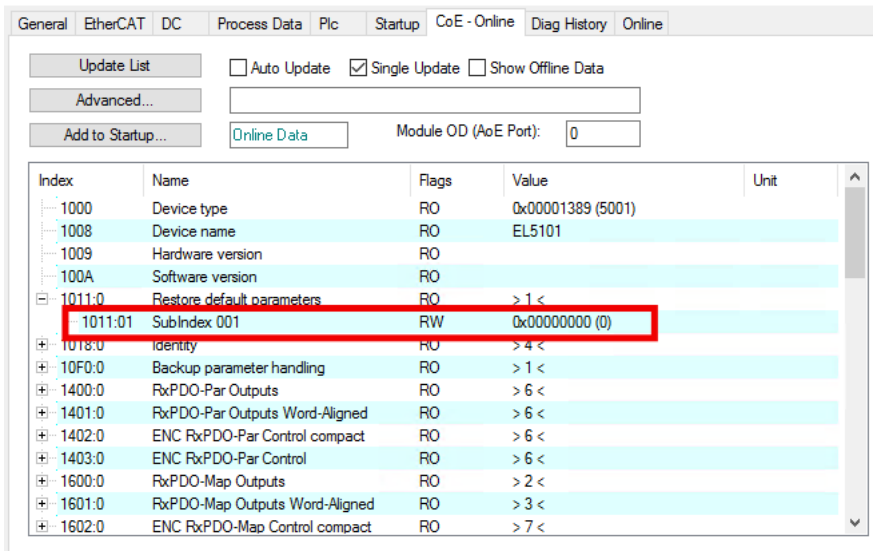

3. Double-click on "Subindex 001".  
⇒ The "Set Value Dialog" dialog box opens.
4. Enter the value 1684107116 in the "Dec" field.  
Alternatively: enter the value 0x64616F6C in the "Hex" field.

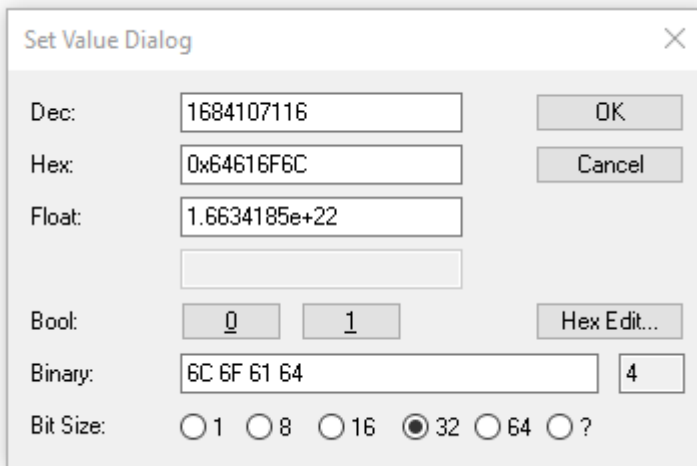

5. Confirm with "OK".  
⇒ All backup objects are reset to the delivery state.

### **i** Alternative restore value

With some older modules the backup objects can be changed with an alternative restore value:

Decimal value: 1819238756

Hexadecimal value: 0x6C6F6164

An incorrect entry for the restore value has no effect.

## 7.9 Decommissioning

**⚠ WARNING****Risk of electric shock!**

Bring the bus system into a safe, de-energized state before starting disassembly of the devices!

## 8 Diagnosis

### 8.1 Status of the IO-Link ports

There is a status byte for each IO-Link port. You can find the status bytes at the following locations:

- In the process data object "Module 2 (DeviceState Inputs)"

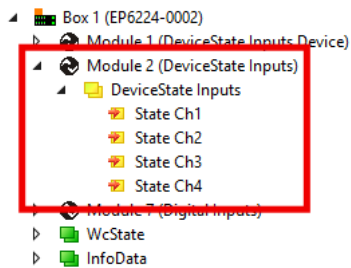

(example for EP6224-0002)

- In the CoE object F100 "Diagnosis Status Data"

#### 8.1.1 Interpretation of the status bytes

The status bytes are divided into two nibbles.

##### Low nibble

Value	Meaning
0x_0	Port disabled
0x_1	Port in std dig in
0x_2	Port in std dig out
0x_3	Port in communication OP
0x_4	Port in communication COMSTOP / dig in Bit (only in std. IO Mode)
0x_5	not defined
0x_6	not defined
0x_7	not defined
0x_8	Process Data Invalid Bit

Combinations are possible and are output as an addition of the values (see note below).

##### Higher nibble

Value	Meaning
0x1_	Watchdog detected
0x2_	internal Error
0x3_	invalid Device ID
0x4_	invalid Vendor ID
0x5_	invalid IO-Link version
0x6_	invalid Frame Capability
0x7_	invalid Cycle Time
0x8_	invalid PD in length
0x9_	invalid PD out length
0xA_	no Device detected
0xB_	error PreOP/Data storage

Combinations are possible and are output as an addition of the values (see note below).

---

**i** **Addition of the values in case of simultaneously occurring diagnosis messages**

If diagnosis messages occur simultaneously, the value is output as a sum in the status byte of the relevant channel.

- Often 0x03 "Port in communication OP" and 0x08 "Process Data Invalid Bit" occur simultaneously:

$$0x03 + 0x08 = 0x0B (11_{dec})$$

⇒ The value 0x0B (11<sub>dec</sub>) is output in the status byte.

---

## 8.2 ADS Error Codes

Error codes are generated in the event of an error during ADS access to an IO-Link device.

The possible error codes are listed in tables C.1 and C.2.

### Example of an AdsReturnCode

AdsReturnCode 0x**80110700**

- **80**: Device Application Error (IO-Link Spec),
- **11**: Index not Available (IO-Link Spec),
- **0700**: General ADS Error

**ErrorTypes (IO-Link Spec)**

Incident	Error Code	Additional Code	Name	Definition
Device application error – no details	0x80	0x00	APP_DEV	This ErrorType shall be used if the requested service has been refused by the Device application and no detailed
Index not available	0x80	0x11	IDX_NOTAVAIL	This ErrorType shall be used whenever a read or write access occurs to a not existing Index.
Subindex not available	0x80	0x12	SUBIDX_NOTAVAIL	This ErrorType shall be used whenever a read or write access occurs to a not existing Subindex.
Service temporarily not available	0x80	0x20	SERV_NOTAVAIL	This ErrorType shall be used if a parameter is not accessible for a read or write service due to the current state of the Device application.
Service temporarily not available – local control	0x80	0x21	SERV_NOTAVAIL_LOCTRL	This ErrorType shall be used if a parameter is not accessible for a read or write service due to an ongoing local operation at the Device (for example operation or parameterization via an on-board Device control panel).
Service temporarily not available – Device control	0x80	0x22	SERV_NOTAVAIL_DEVCTRL	This ErrorType shall be used if a read or write service is not accessible due to a remote triggered state of the device application (for example parameterization during a remote triggered teach-in operation or calibration).
Access denied	0x80	0x23	IDX_NOT_WRITEABLE	This ErrorType shall be used if a write service tries to access a read-only parameter.
Parameter value out of range	0x80	0x30	PAR_VALOUTOFRNG	This ErrorType shall be used for a write service to a parameter outside its permitted range of values.
Parameter value above limit	0x80	0x31	PAR_VALGLTLM	This ErrorType shall be used for a write service to a parameter above its specified value range.
Parameter value below limit	0x80	0x32	PAR_VALLTLM	This ErrorType shall be used for a write service to a parameter below its specified value range.
Parameter length overrun	0x80	0x33	VAL_LENVERRUN	This ErrorType shall be used when the content of a write service to a parameter is greater than the parameter specified length. This ErrorType shall also be used, if a data object is too large to be processed by the Device application (for example ISDU buffer restriction).
Parameter length underrun	0x80	0x34	VAL_LENUNDRUN	This ErrorType shall be used when the content of a write service to a parameter is less than the parameter specified length (for example write access of an Unsigned16 value to an Unsigned32 parameter).
Function not available	0x80	0x35	FUNC_NOTAVAIL	This ErrorType shall be used for a write service with a command value not supported by the Device application (for example a SystemCommand with a value not implemented).
Function temporarily unavailable	0x80	0x36	FUNC_UNAVAILTEMP	This ErrorType shall be used for a write service with a command value calling a Device function not available due to the current state of the Device application (for example a SystemCommand).
Invalid parameter set	0x80	0x40	PAR_SETINVALID	This ErrorType shall be used if values sent via single parameter transfer are not consistent with other actual parameter settings (for example overlapping set points for a binary data setting)
Inconsistent parameter set	0x80	0x41	PAR_SETINCONSIST	This ErrorType shall be used at the termination of a block parameter transfer with ParamDownloadEnd or ParamDownloadStore if the plausibility check shows inconsistencies
Application not ready	0x80	0x82	APP_DEVNOTRDY	This ErrorType shall be used if a read or write service is refused due to a temporarily unavailable application (for example peripheral controllers during startup).
Vendor specific	0x81	0x00	UNSPECIFIC	This ErrorType will be propagated directly to higher level processing elements as an error (no warning) by the Master.
Vendor specific	0x81	0x01 to 0xFF	VENDOR_SPECIFIC	

Table C.1 ErrorTypes, IO-Link Spec

**Derived ErrorTypes (IO-Link Spec)**

Incident	Error Code	Additional Code	Name	Definition
Master – Communication error	0x10	0x00	COM_ERR	The Master generates a negative service response with this ErrorType if a communication error occurred during a read or write service, for example the SDCI connection is interrupted.
Master – ISDU timeout	0x11	0x00	I-SERVICE_TIMEOUT	The Master generates a negative service response with this ErrorType, if a Read or Write service is pending longer than the specified I-Service timeout in the Master.
Device Event – ISDU error (DL, Error, single shot, 0x5600)	0x11	0x00	I-SERVICE_TIMEOUT	If the Master received an Event with the EventQualifier and the EventCode 0x5600, a negative service response indicating a service timeout is generated and returned to the requester (Master – ISDU timeout).
Device Event – ISDU illegal service primitive (AL, Error, single shot, 0x5800)	0x11	0x00	I-SERVICE_TIMEOUT	If the Master received an Event with the EventQualifier and the EventCode 0x5800, a negative service response indicating a service timeout is generated and returned to the requester (Master – ISDU timeout).
Master – ISDU checksum error	0x56	0x00	M_ISDU_CHECKSUM	The Master generates a negative service response with this ErrorType, if its data link layer detects an ISDU checksum error.
Master – ISDU illegal service primitive	0x57	0x00	M_ISDU_ILLEGAL	The Master generates a negative service response with this ErrorType, if its data link layer detects an ISDU illegal service primitive.
Device Event – ISDU buffer overflow (DL, Error, single shot, 0x5200)	0x80	0x33	VAL_LENVERRUN	If the Master received an Event with the EventQualifier and the EventCode 0x5200, a negative service response indicating a parameter length overrun is generated and returned to the requester (see parameter length overrun)  Events from legacy Devices shall be redirected in compatibility mode to this derived ErrorType

Table C.2 Derived ErrorTypes, IO-Link Spec

## 8.3 Further error diagnosis

### Device State Inputs Device (0x1A05)

It is indicated in the PDO "Device Diag" (0xF101:0D) that at least one event has occurred in the "Diag History".

"Device State" is the standard status bit for EtherCAT slaves and shows, for example, that communication with one of the slaves has been interrupted.

### DeviceState Inputs (0x1A04)

The status of the IO-Link ports is mapped as a status byte in the "DeviceState Inputs" process data object. See chapter [Status of the IO-Link ports \[▶ 88\]](#).

### Nominal/actual comparison of the parameter objects

The indices 0x90n0 (Info data) can be referred to for validation of the configuration indices 0x80n0 of the connected IO-Link device.

In case of error these objects can be used to compare the configuration with the actual state.

### Lost Frame Counter

The Lost Frame counter in object 0xA0n0:02 is for the diagnosis of the transmission quality. TwinCAT provides the possibility here to diagnose problems, e. g. with the wiring, EMC or power supply.

## 9 CoE objects

### 9.1 EPP6224-0002

Index (hex)	Name
1000	Device type [ <a href="#">▶ 100</a> ]
1008	Device name [ <a href="#">▶ 100</a> ]
1009	Hardware version [ <a href="#">▶ 100</a> ]
100A	Software version [ <a href="#">▶ 100</a> ]
1010	Store parameters [ <a href="#">▶ 100</a> ]
1011	Restore default parameters [ <a href="#">▶ 100</a> ]
1018	Identity [ <a href="#">▶ 100</a> ]
10F0	Backup parameter handling [ <a href="#">▶ 101</a> ]
10F2	Backup parameter storage [ <a href="#">▶ 101</a> ]
10F3	Diagnosis History [ <a href="#">▶ 101</a> ]
10F8	Actual Time Stamp [ <a href="#">▶ 101</a> ]
1600	I/O RxPDO-Map Outputs Ch.1 [ <a href="#">▶ 101</a> ]
1601	I/O RxPDO-Map Outputs Ch.2 [ <a href="#">▶ 101</a> ]
1602	I/O RxPDO-Map Outputs Ch.3 [ <a href="#">▶ 101</a> ]
1603	I/O RxPDO-Map Outputs Ch.4 [ <a href="#">▶ 101</a> ]
1A00	I/O TxPDO-Map Inputs Ch.1 [ <a href="#">▶ 102</a> ]
1A01	I/O TxPDO-Map Inputs Ch.2 [ <a href="#">▶ 102</a> ]
1A02	I/O TxPDO-Map Inputs Ch.3 [ <a href="#">▶ 102</a> ]
1A03	I/O TxPDO-Map Inputs Ch.4 [ <a href="#">▶ 102</a> ]
1A80	DeviceState TxPDO-Map Inputs [ <a href="#">▶ 102</a> ]
1A81	DeviceState TxPDO-Map Inputs [ <a href="#">▶ 102</a> ]
1C00	Sync Manager type [ <a href="#">▶ 102</a> ]
1C12	RxPDO assign [ <a href="#">▶ 103</a> ]
1C13	TxPDO assign [ <a href="#">▶ 103</a> ]
1C32	SM output parameter [ <a href="#">▶ 104</a> ]
1C33	SM input parameter [ <a href="#">▶ 105</a> ]
8000	I/O Settings Ch.1 [ <a href="#">▶ 95</a> ]
8010	I/O Settings Ch.2 [ <a href="#">▶ 95</a> ]
8020	I/O Settings Ch.3 [ <a href="#">▶ 95</a> ]
8030	I/O Settings Ch.4 [ <a href="#">▶ 95</a> ]
9000	I/O Info data Ch.1 [ <a href="#">▶ 97</a> ]
9010	I/O Info data Ch.2 [ <a href="#">▶ 97</a> ]
9020	I/O Info data Ch.3 [ <a href="#">▶ 97</a> ]
9030	I/O Info data Ch.4 [ <a href="#">▶ 97</a> ]
A000	I/O Diag data Ch.1 [ <a href="#">▶ 98</a> ]
A010	I/O Diag data Ch.2 [ <a href="#">▶ 98</a> ]
A020	I/O Diag data Ch.3 [ <a href="#">▶ 98</a> ]
A030	I/O Diag data Ch.4 [ <a href="#">▶ 98</a> ]
F000	Modular device profile [ <a href="#">▶ 105</a> ]
F008	Code word [ <a href="#">▶ 105</a> ]
F010	Module list [ <a href="#">▶ 106</a> ]
F100	Diagnosis Status data [ <a href="#">▶ 98</a> ]
F101	DeviceState Status data [ <a href="#">▶ 98</a> ]
F820	ADS Server Settings [ <a href="#">▶ 96</a> ]
F900	Info data [ <a href="#">▶ 99</a> ]

## 9.1.1 Configuration objects

### 800n IO Settings Ch.x

- 8000: IO Settings Ch.1
- 8001: IO Settings Ch.2
- 8002: IO Settings Ch.3
- 8003: IO Settings Ch.4

**● Recommendation: Configuration via configuration tool**

**i** TwinCAT includes a graphical configuration tool for IO-Link masters and IO-Link devices. With this tool the configuration is easier and clearer than via the CoE parameters.

See chapter [Configuration of the IO link master \[► 53\]](#).

Subindex (hex)	Name	Meaning	Data Type	Flags	Default																				
0	IO Settings Ch.x		USINT	RO	0x28 (40 <sub>dec</sub> )																				
04	Device ID	The Device ID is used for validating the IO-Link device.	UDINT	RW	-																				
05	Vendor ID	The Vendor ID is used for validating the vendor of the IO-Link device.	UDINT	RW	-																				
20	IO-Link Revision	The version of the IO-Link specification according to which the IO-Link device communicates. Bit 0-3: MinorRev Bit 4-7: MajorRev	USINT	RW	-																				
21	Frame capability	Frame capability indicates certain functionalities of the IO-Link device (e.g. SPDU supported). Bit 0: SPDU Bit 1: Type1 Bit 7: PHY1	USINT	RW	-																				
22	Min cycle time	The cycle time at which the IO-Link master should communicate with the IO-Link device. This value is transferred in the IO-Link format for Min Cycle Time. Bit 6 and 7: Time Base Bit 0 to 5: Multiplier 0x00: The IO-Link master automatically uses the smallest possible update time of the IO-Link device.	USINT	RW	-																				
		<table border="1"> <thead> <tr> <th>Time Base</th> <th>Meaning Time base</th> <th>Calculation</th> <th>Min. Cycle Time</th> </tr> </thead> <tbody> <tr> <td>00<sub>bin</sub></td> <td>0.1ms</td> <td>Multiplier x Time Base</td> <td>0.4 - 6.3 ms</td> </tr> <tr> <td>01<sub>bin</sub></td> <td>0.4ms</td> <td>6.4 ms + Multiplier x Time Base</td> <td>6.4 - 31.6 ms</td> </tr> <tr> <td>10<sub>bin</sub></td> <td>1.6ms</td> <td>32.0 ms + Multiplier x Time Base</td> <td>32.0 - 132.8 ms</td> </tr> <tr> <td>11<sub>bin</sub></td> <td>6.4 ms</td> <td>134.4 ms + Multiplier x Time Base</td> <td>134.4 - 537.6 ms</td> </tr> </tbody> </table>	Time Base	Meaning Time base	Calculation	Min. Cycle Time	00 <sub>bin</sub>	0.1ms	Multiplier x Time Base	0.4 - 6.3 ms	01 <sub>bin</sub>	0.4ms	6.4 ms + Multiplier x Time Base	6.4 - 31.6 ms	10 <sub>bin</sub>	1.6ms	32.0 ms + Multiplier x Time Base	32.0 - 132.8 ms	11 <sub>bin</sub>	6.4 ms	134.4 ms + Multiplier x Time Base	134.4 - 537.6 ms			
Time Base	Meaning Time base	Calculation	Min. Cycle Time																						
00 <sub>bin</sub>	0.1ms	Multiplier x Time Base	0.4 - 6.3 ms																						
01 <sub>bin</sub>	0.4ms	6.4 ms + Multiplier x Time Base	6.4 - 31.6 ms																						
10 <sub>bin</sub>	1.6ms	32.0 ms + Multiplier x Time Base	32.0 - 132.8 ms																						
11 <sub>bin</sub>	6.4 ms	134.4 ms + Multiplier x Time Base	134.4 - 537.6 ms																						
23	Offset time	reserved	USINT	RW	-																				

Subindex (hex)	Name	Meaning	Data Type	Flags	Default
24	Process data in length	These parameters are transferred in the IO-Link format for "Process data in length".  Bit 7: BYTE (indicates whether the value in LENGTH is interpreted as bit length [bit not set] or as byte length + 1 [bit set])  Bit 6: SIO (indicates whether the device supports the standard I/O mode [bit set])  Bit 0 to 4: LENGTH (Length of the process data)	USINT	RW	-
25	Process data out length	These parameters are transferred in the IO-Link format for "Process data out length".  Bit 7: BYTE (indicates whether the value in LENGTH is interpreted as bit length [bit not set] or as byte length + 1 [bit set])  Bit 6: SIO (indicates whether the device supports the standard I/O mode [bit set])  Bit 0 to 4: LENGTH (Length of the process data)	USINT	RW	-
26	Compatible ID	reserved	UINT	RW	-
27	Reserved	reserved	UINT	RW	-
28	Master Control	Possible values: <ul style="list-style-type: none"> <li>• 0: IO-Link port inactive</li> <li>• 1: IO-Link port as digital input</li> <li>• 2: IO-Link port as digital output</li> <li>• 3: IO-Link port in communication via the IO-Link protocol.</li> </ul> 4: IO-Link port in communication via the IO-Link protocol. The IO-Link state is ComStop (no cyclic communication, data is only exchanged when required).	UINT	RW	-

### F820 ADS Server Settings

Index (hex)	Name	Meaning	Data Type	Flags	Default
F820:0	ADS Server Settings		USINT	RO	0x2 (2 <sub>dec</sub> )
F820:01	Net ID	NetId and port to which the DiagHistory messages can be sent via emergency	ARRAY [0..5] OF BYTE	RW	-
F820:02	Port		UINT	RW	-

## 9.1.2 Information objects

### 90n0 IO Info data Ch.x

- 9000: IO Info data Ch.1
- 9010: IO Info data Ch.2
- 9020: IO Info data Ch.3
- 9030: IO Info data Ch.4

Subindex (hex)	Name	Meaning	Data Type	Flags	Default																				
0	IO Info data Ch.x		USINT	RO	0x27 (39 <sub>dec</sub> )																				
04	Device ID	The device ID is used for validating the IO-Link device.	UDINT	RO	-																				
05	Vendor ID	The vendor ID is used for validating the manufacturer of the IO-Link device.	UDINT	RO	-																				
20	IO-Link Revision	ID of the specification version based on which the IO-Link device communicates. Bit 0-3: MinorRev Bit 4-7: MajorRev	USINT	RO	-																				
21	Frame capability	The Frame Capability indicates certain functionalities of the IO-Link device (e.g. SPDU supported). Bit 0: SPDU Bit 1: Type1 Bit 7: PHY1	USINT	RO	-																				
22	Min cycle time	The cycle time refers to the communication between the IO-Link master and the IO-Link device. This value is transferred in the IO-Link format for Min Cycle Time. Bit 6 and 7: Time Base Bit 0 to 5: Multiplier <table border="1" data-bbox="571 1102 1054 1496"> <thead> <tr> <th>Time Base</th> <th>Meaning Time base</th> <th>Calculation</th> <th>Min. Cycle Time</th> </tr> </thead> <tbody> <tr> <td>00b</td> <td>0,100 ms</td> <td>Multiplier x Time Base</td> <td>0,000 - 6,300 ms</td> </tr> <tr> <td>01b</td> <td>0,400 ms</td> <td>6,400 ms + Multiplier x Time Base</td> <td>6,400 - 31,600 ms</td> </tr> <tr> <td>10b</td> <td>1,600 ms</td> <td>32,000 ms + Multiplier x Time Base</td> <td>32,000 - 132,800 ms</td> </tr> <tr> <td>11b</td> <td>6,400 ms</td> <td>134,400 ms + Multiplier x Time Base</td> <td>134,400 - 537,600 ms</td> </tr> </tbody> </table>	Time Base	Meaning Time base	Calculation	Min. Cycle Time	00b	0,100 ms	Multiplier x Time Base	0,000 - 6,300 ms	01b	0,400 ms	6,400 ms + Multiplier x Time Base	6,400 - 31,600 ms	10b	1,600 ms	32,000 ms + Multiplier x Time Base	32,000 - 132,800 ms	11b	6,400 ms	134,400 ms + Multiplier x Time Base	134,400 - 537,600 ms	USINT	RO	-
Time Base	Meaning Time base	Calculation	Min. Cycle Time																						
00b	0,100 ms	Multiplier x Time Base	0,000 - 6,300 ms																						
01b	0,400 ms	6,400 ms + Multiplier x Time Base	6,400 - 31,600 ms																						
10b	1,600 ms	32,000 ms + Multiplier x Time Base	32,000 - 132,800 ms																						
11b	6,400 ms	134,400 ms + Multiplier x Time Base	134,400 - 537,600 ms																						
23	Offset time	reserved	USINT	RO	-																				
24	Process data in length	These parameters are transferred in the IO-Link format for "Process data in length". Bit 7: BYTE (indicates whether the value in LENGTH is interpreted as bit length [bit not set] or as byte length + 1 [bit set]) Bit 6: SIO (indicates whether the device supports the standard I/O mode [bit set]) Bit 0 to 4: LENGTH (Length of the process data)	USINT	RO	-																				

Subindex (hex)	Name	Meaning	Data Type	Flags	Default
25	Process data out length	These parameters are transferred in the IO-Link format for "Process data out length".  Bit 7: BYTE (indicates whether the value in LENGTH is interpreted as bit length [bit not set] or as byte length + 1 [bit set])  Bit 6: SIO (indicates whether the device supports the standard I/O mode [bit set])  Bit 0 to 4: LENGTH (Length of the process data)	USINT	RO	-
26	Reserved	reserved	UINT	RO	-
27	Reserved2	reserved	UINT	RO	-

### A0n0 IO Diag data Ch.x

- A000: IO Info data Ch.1
- A010: IO Info data Ch.2
- A020: IO Info data Ch.3
- A030: IO Info data Ch.4

Index (hex)	Name	Meaning	Data Type	Flags	Default
A000:0	IO Diag data Ch.x		USINT	RO	0x2 (2 <sub>dec</sub> )
A000:01	IO-Link State	The value of the IO-Link state corresponds to a state from the IO-Link master state machine  0: INACTIVE 1: DIGINPUT 2: DIGOUTPUT 3: ESTABLISHCOMM 4: INITMASTER 5: INITDEVICE  7: PREOPERATE 8: OPERATE 9: STOP	USINT	RO	-
A000:02	Lost Frames	This parameter counts the number of lost IO-Link telegrams. This value is deleted whenever IO-Link starts up, otherwise it is incremented continuously.	USINT	RO	-

### F100 Diagnosis Status data

See chapter [Status of the IO-Link ports \[► 88\]](#).

Index (hex)	Name	Meaning	Data Type	Flags	Default
F100:0	Diagnosis Status data		USINT	RO	0x4 (4 <sub>dec</sub> )
F100:01	State Ch1	IO-Link Status byte Ch. 1	USINT	RO	-
F100:02	State Ch2	IO-Link Status byte Ch. 2	USINT	RO	-
F100:03	State Ch3	IO-Link Status byte Ch. 3	USINT	RO	-
F100:04	State Ch4	IO-Link Status byte Ch. 4	USINT	RO	-

### F101 DeviceState Status data

Index (hex)	Name	Meaning	Data Type	Flags	Default
F101:0	DeviceState Status data		USINT	RO	0x10 (16 <sub>dec</sub> )
F101:0D	Device Diag	-	BOOL	RO	-
F101:10	Device State	-	BOOL	RO	-

**F900 Info data**

Index (hex)	Name	Meaning	Data Type	Flags	Default
F900:0	Info data		USINT	RO	0x1 (1 <sub>dec</sub> )
F900:01	IO-Link Version	-	USINT	RO	-

## 9.1.3 Standard objects

### 1000 Device type

Index (hex)	Name	Meaning	Data Type	Flags	Default
1000:0	Device type	Device type of the EtherCAT slave: the Lo-Word contains the used CoE profile (5001). The Hi-Word contains the module profile according to the modular device profile.	UDINT	RO	0x89134C18 (2299743256 <sub>dec</sub> )

### 1008 Device name

Index (hex)	Name	Meaning	Data Type	Flags	Default
1008:0	Device name	Device name of the EtherCAT slave	STRING(12)	RO	EPP6224-000 2

### 1009 Hardware version

Index (hex)	Name	Meaning	Data Type	Flags	Default
1009:0	Hardware version	Hardware version of the EtherCAT slave	STRING(2)	RO	-

### 100A Software version

Index (hex)	Name	Meaning	Data Type	Flags	Default
100A:0	Software version	Firmware version of the EtherCAT slave	STRING(2)	RO	-

### 1010 Store parameters

Index (hex)	Name	Meaning	Data Type	Flags	Default
1010:0	Store parameters		USINT	RO	0x1 (1 <sub>dec</sub> )

### 1011 Restore default parameters

Index (hex)	Name	Meaning	Data Type	Flags	Default
1011:0	Restore default parameters	Restoring the default parameters	USINT	RO	0x1 (1 <sub>dec</sub> )
1011:01	SubIndex 001	If this object is set to "0x64616F6C" in the set value dialog, all backup objects are reset to their delivery state.	UINT32	RW	0x00000000 (0 <sub>dec</sub> )

### 1018 Identity

Index (hex)	Name	Meaning	Data Type	Flags	Default
1018:0	Identity	Information for identifying the slave	USINT	RO	0x4 (4 <sub>dec</sub> )
1018:01	Vendor ID	Vendor ID of the EtherCAT slave	UDINT	RO	0x2 (2 <sub>dec</sub> )
1018:02	Product code	Product code of the EtherCAT slave	UDINT	RO	0x64774B09 (1685539593 <sub>dec</sub> )
1018:03	Revision	Revision number of the EtherCAT slave; the low word (bit 0-15) indicates the special terminal number, the high word (bit 16-31) refers to the device description	UDINT	RO	-
1018:04	Serial number	Serial number of the EtherCAT slave; the low byte (bit 0-7) of the low word contains the year of production, the high byte (bit 8-15) of the low word contains the week of production, the high word (bit 16-31) is 0	UDINT	RO	-

**10F0 Backup parameter handling**

Index (hex)	Name	Meaning	Data Type	Flags	Default
10F0:0	Backup parameter handling	Information for standardized loading and saving of backup entries	USINT	RO	0x1 (1 <sub>dec</sub> )
10F0:01	Checksum	Checksum across all backup entries of the EtherCAT slave	UDINT	RO	-

**10F2 Backup parameter storage**

Index (hex)	Name	Meaning	Data Type	Flags	Default
10F2:0	Backup parameter storage	-	ARRAY [0..3] OF BYTE	RO	-

**10F3 Diagnosis History**

Index (hex)	Name	Meaning	Data Type	Flags	Default
10F3:0	Diagnosis History	Maximum subindex	USINT	RO	0x15 (21 <sub>dec</sub> )
10F3:01	Maximum Messages	Maximum number of stored messages A maximum of 16 messages can be saved	USINT	RO	-
10F3:02	Newest Message	Subindex of the latest message	USINT	RO	-
10F3:03	Newest Acknowledged Message	Subindex of the last acknowledged message	USINT	RW	-
10F3:04	New Messages Available	Indicates that a new message is available	BOOL	RO	-
10F3:05	Flags		UINT	RW	-
10F3:06	Diagnosis Message 001	Message 1	ARRAY [0..27] OF BYTE	RO	-
10F3:07	Diagnosis Message 002	Message 2	ARRAY [0..27] OF BYTE	RO	-
10F3:08	Diagnosis Message 003	Message 3	ARRAY [0..27] OF BYTE	RO	-
...	...	...	...	...	...
10F3:13	Diagnosis Message 014	Message 14	ARRAY [0..27] OF BYTE	RO	-
10F3:14	Diagnosis Message 015	Message 15	ARRAY [0..27] OF BYTE	RO	-
10F3:15	Diagnosis Message 016	Message 16	ARRAY [0..27] OF BYTE	RO	-

**10F8 Actual Time Stamp**

Index (hex)	Name	Meaning	Data Type	Flags	Default
10F8:0	Actual Time Stamp	-	ULINT	RO	-

**160n IO RxPDO-Map Outputs Ch.x**

- 1600: IO Settings Ch.1
- 1601: IO Settings Ch.2
- 1602: IO Settings Ch.3
- 1603: IO Settings Ch.4

Subindex (hex)	Name	Meaning	Data Type	Flags	Default
0	IO RxPDO-Map Outputs Ch.x	-	USINT	RO	-
01	SubIndex 001		UDINT	RW	0x0000:00, 0
02	SubIndex 002		UDINT	RW	0x0000:00, 0
03	SubIndex 003		UDINT	RW	0x0000:00, 0
04	SubIndex 004		UDINT	RW	0x0000:00, 0
...	...	...	...	...	...
3E	SubIndex 062		UDINT	RW	0x0000:00, 0
3F	SubIndex 063		UDINT	RW	0x0000:00, 0
40	SubIndex 064		UDINT	RW	0x0000:00, 0

### 1A0n IO TxPDO-Map Inputs Ch.x

- 1A00: TxPDO-Map Inputs Ch.1
- 1A01: TxPDO-Map Inputs Ch.2
- 1A02: TxPDO-Map Inputs Ch.3
- 1A03: TxPDO-Map Inputs Ch.4

Index (hex)	Name	Meaning	Data Type	Flags	Default
1A00:0	IO TxPDO-Map Inputs Ch.1	-	USINT	RO	-
1A00:01	SubIndex 001		UDINT	RW	0x0000:00, 0
1A00:02	SubIndex 002		UDINT	RW	0x0000:00, 0
1A00:03	SubIndex 003		UDINT	RW	0x0000:00, 0
...	...	...	...	...	...
1A00:3E	SubIndex 062		UDINT	RW	0x0000:00, 0
1A00:3F	SubIndex 063		UDINT	RW	0x0000:00, 0
1A00:40	SubIndex 064		UDINT	RW	0x0000:00, 0

### 1A80 DeviceState TxPDO-Map Inputs

Index (hex)	Name	Meaning	Data Type	Flags	Default
1A80:0	DeviceState TxPDO-Map Inputs		USINT	RO	0x4 (4 <sub>dec</sub> )
1A80:01	SubIndex 001	PDO Mapping Entry for "State Ch1".	UDINT	RO	0xf100:01, 8
1A80:02	SubIndex 002	PDO Mapping Entry for "State Ch2".	UDINT	RO	0xf100:02, 8
1A80:03	SubIndex 003	PDO Mapping Entry for "State Ch3".	UDINT	RO	0xf100:03, 8
1A80:04	SubIndex 004	PDO Mapping Entry for "State Ch4".	UDINT	RO	0xf100:04, 8

### 1A81 DeviceState TxPDO-Map Inputs

Index (hex)	Name	Meaning	Data Type	Flags	Default
1A81:0	DeviceState TxPDO-Map Inputs		USINT	RO	0x4 (4 <sub>dec</sub> )
1A81:01	SubIndex 001		UDINT	RO	0x0000:00, 12
1A81:02	SubIndex 002	PDO Mapping Entry for "Device Diag".	UDINT	RO	0xf101:0d, 1
1A81:03	SubIndex 003		UDINT	RO	0x0000:00, 2
1A81:04	SubIndex 004	PDO Mapping Entry for "Device State".	UDINT	RO	0xf101:10, 1

### 1C00 Sync manager type

Index (hex)	Name	Meaning	Data Type	Flags	Default
1C00:0	Sync manager type		USINT	RO	0x4 (4 <sub>dec</sub> )
1C00:01	SubIndex 001	Sync Manager Type Channel 1: Mailbox Write	USINT	RO	0x1 (1 <sub>dec</sub> )
1C00:02	SubIndex 002	Sync Manager Type Channel 2: Mailbox Read	USINT	RO	0x2 (2 <sub>dec</sub> )
1C00:03	SubIndex 003	Sync Manager Type Channel 3: Process Data Write (Outputs)	USINT	RO	0x3 (3 <sub>dec</sub> )
1C00:04	SubIndex 004	Sync Manager Type Channel 4: Process Data Read (Inputs)	USINT	RO	0x4 (4 <sub>dec</sub> )

**1C12 RxPDO assign**

Index (hex)	Name	Meaning	Data Type	Flags	Default
1C12:0	RxPDO assign		USINT	RO	0x4 (4 <sub>dec</sub> )
1C12:01	SubIndex 001		UINT	RW	0x16 (22 <sub>dec</sub> )
1C12:02	SubIndex 002		UINT	RW	0x116 (278 <sub>dec</sub> )
1C12:03	SubIndex 003		UINT	RW	0x216 (534 <sub>dec</sub> )
1C12:04	SubIndex 004		UINT	RW	0x316 (790 <sub>dec</sub> )

**1C13 TxPDO assign**

Index (hex)	Name	Meaning	Data Type	Flags	Default
1C13:0	TxPDO assign		USINT	RO	0x6 (6 <sub>dec</sub> )
1C13:01	SubIndex 001		UINT	RW	0x1A (26 <sub>dec</sub> )
1C13:02	SubIndex 002		UINT	RW	0x11A (282 <sub>dec</sub> )
1C13:03	SubIndex 003		UINT	RW	0x21A (538 <sub>dec</sub> )
1C13:04	SubIndex 004		UINT	RW	0x31A (794 <sub>dec</sub> )
1C13:05	SubIndex 005		UINT	RW	0x801A (32794 <sub>dec</sub> )
1C13:06	SubIndex 006		UINT	RW	0x811A (33050 <sub>dec</sub> )

## 1C32 SM output parameter

Index (hex)	Name	Meaning	Data Type	Flags	Default
1C32:0	SM output parameter	Synchronization parameters for the outputs	USINT	RO	0x20 (32 <sub>dec</sub> )
1C32:01	Sync mode	Current synchronization mode: 0: Free Run 1: Synchronous with SM 2 Event 2: DC-Mode - synchronous with SYNC0 Event 3: DC-Mode - synchronous with SYNC1 Event	UINT	RW	0x1 (1 <sub>dec</sub> )
1C32:02	Cycle time	Cycle time (in ns): Free Run: cycle time of the local timer Synchronous with SM 2 Event: cycle time of the master DC-Mode: SYNC0/SYNC1 Cycle Time	UDINT	RW	0x7A120 (500000 <sub>dec</sub> )
1C32:03	Shift time	Time between SYNC0 event and output of the outputs (in ns, DC mode only)	UDINT	RO	0x0 (0 <sub>dec</sub> )
1C32:04	Sync modes supported	Sync modes supported: Bit 0 = 1: Free Run is supported Bit 1 = 1: Synchronization with SM 2 Event is supported Bit 2-3 = 01: DC-Mode is supported Bit 4-5 = 10: Output Shift with SYNC1 Event (DC mode only) Bit 14 = 1: dynamic times (measurement through writing of 1C32:08)	UINT	RO	0x3 (3 <sub>dec</sub> )
1C32:05	Minimum cycle time	Minimum cycle time (in ns)	UDINT	RO	0x186A0 (100000 <sub>dec</sub> )
1C32:06	Calc and copy time	Minimum time between SYNC0 and SYNC1 event (in ns, DC Mode only)	UDINT	RO	0x0 (0 <sub>dec</sub> )
1C32:07	Minimum delay time		UDINT	RO	0x0 (0 <sub>dec</sub> )
1C32:08	Command	0: Measurement of the local cycle time is stopped 1: Measurement of the local cycle time is started The entries 1C32:03, 1C32:05, 1C32:06, 1C32:09, 1C33:03, 1C33:06, 1C33:09 are updated with the maximum measured values. For a subsequent measurement the measured values are reset	UINT	RW	0x0 (0 <sub>dec</sub> )
1C32:09	Maximum delay time	Time between SYNC1 event and output of the outputs (in ns, DC mode only)	UDINT	RO	0x0 (0 <sub>dec</sub> )
1C32:0B	SM event missed counter	Number of missed SM events in OPERATIONAL (DC Mode only)	UINT	RO	-
1C32:0C	Cycle exceeded counter	Number of occasions the cycle time was exceeded in OPERATIONAL (cycle was not completed in time or the next cycle began too early)	UINT	RO	-
1C32:0D	Shift too short counter	Number of intervals between SYNC0 and SYNC1 events that are too short (DC Mode only)	UINT	RO	-
1C32:20	Sync error	The synchronization was not correct in the last cycle (outputs were output too late; DC Mode only)	BOOL	RO	-

**1C33 SM input parameter**

Index (hex)	Name	Meaning	Data Type	Flags	Default
1C33:0	SM input parameter	Synchronization parameters for the inputs	USINT	RO	0x20 (32 <sub>dec</sub> )
1C33:01	Sync mode	Current synchronization mode: 0: Free Run 1: Synchronous with SM 3 Event (no outputs available) 2: DC - Synchronous with SYNC0 Event 3: DC - Synchronous with SYNC1 Event 34: Synchronous with SM 2 Event (outputs available)	UINT	RW	0x22 (34 <sub>dec</sub> )
1C33:02	Cycle time	as 1C32:02	UDINT	RW	0x7A120 (500000 <sub>dec</sub> )
1C33:03	Shift time	Time between SYNC0 event and reading of the inputs (in ns, DC Mode only)	UDINT	RO	0x0 (0 <sub>dec</sub> )
1C33:04	Sync modes supported	Sync modes supported: Bit 0: Free Run is supported Bit 1: Synchronization with SM 2 Event is supported (outputs available) Bit 1: Synchronization with SM 3 Event is supported (no outputs available) Bit 2-3 = 01: DC-Mode is supported Bit 4-5 = 01: Input shift through local event (outputs available) Bit 4-5 = 10: Input shift with SYNC1 event (no outputs available) Bit 14 = 1: dynamic times (measurement through writing of 1C32:08 or 1C33:08)	UINT	RO	0x3 (3 <sub>dec</sub> )
1C33:05	Minimum cycle time	as 1C32:05	UDINT	RO	0x186A0 (100000 <sub>dec</sub> )
1C33:06	Calc and copy time	Time between reading of the inputs and the inputs being available for the master (in ns, DC Mode only)	UDINT	RO	0x0 (0 <sub>dec</sub> )
1C33:07	Minimum delay time		UDINT	RO	0x0 (0 <sub>dec</sub> )
1C33:08	Command	as 1C32:08	UINT	RW	0x0 (0 <sub>dec</sub> )
1C33:09	Maximum delay time	Time between SYNC1 event and reading of the inputs (in ns, DC Mode only)	UDINT	RO	0x0 (0 <sub>dec</sub> )
1C33:0B	SM event missed counter	as 1C32:11	UINT	RO	-
1C33:0C	Cycle exceeded counter	as 1C32:12	UINT	RO	-
1C33:0D	Shift too short counter	as 1C32:13	UINT	RO	-
1C33:20	Sync error	as 1C32:32	BOOL	RO	-

**F000 Modular device profile**

Index (hex)	Name	Meaning	Data Type	Flags	Default
F000:0	Modular device profile		USINT	RO	0x2 (2 <sub>dec</sub> )
F000:01	Module index distance		UINT	RO	0x10 (16 <sub>dec</sub> )
F000:02	Maximum number of modules		UINT	RO	0x8 (8 <sub>dec</sub> )

**F008 Code word**

Index (hex)	Name	Meaning	Data Type	Flags	Default
F008:0	Code word	-	UDINT	RO	-

**F010 Module list**

Index (hex)	Name	Meaning	Data Type	Flags	Default
F010:0	Module list		USINT	RO	0x4 (4 <sub>dec</sub> )
F010:01	SubIndex 001		UDINT	RW	0x4C180000 (1276641280 <sub>d</sub> ec)
F010:02	SubIndex 002		UDINT	RW	0x4C180000 (1276641280 <sub>d</sub> ec)
F010:03	SubIndex 003		UDINT	RW	0x4C180000 (1276641280 <sub>d</sub> ec)
F010:04	SubIndex 004		UDINT	RW	0x4C180000 (1276641280 <sub>d</sub> ec)

## 9.2 EPP6224-0522

Index (hex)	Name
1000	<a href="#">Device type [▶ 113]</a>
1008	<a href="#">Device name [▶ 113]</a>
1009	<a href="#">Hardware version [▶ 113]</a>
100A	<a href="#">Software version [▶ 113]</a>
1010	<a href="#">Store parameters [▶ 113]</a>
1011	<a href="#">Restore default parameters [▶ 113]</a>
1018	<a href="#">Identity [▶ 113]</a>
10F0	<a href="#">Backup parameter handling [▶ 114]</a>
10F2	<a href="#">Backup parameter storage [▶ 114]</a>
10F3	<a href="#">Diagnosis History [▶ 114]</a>
10F8	<a href="#">Actual Time Stamp [▶ 114]</a>
1600	<a href="#">I/O RxPDO-Map Outputs Ch.1 [▶ 114]</a>
1601	<a href="#">I/O RxPDO-Map Outputs Ch.2 [▶ 114]</a>
1602	<a href="#">I/O RxPDO-Map Outputs Ch.3 [▶ 114]</a>
1603	<a href="#">I/O RxPDO-Map Outputs Ch.4 [▶ 114]</a>
1A00	<a href="#">I/O TxPDO-Map Inputs Ch.1 [▶ 115]</a>
1A01	<a href="#">I/O TxPDO-Map Inputs Ch.2 [▶ 115]</a>
1A02	<a href="#">I/O TxPDO-Map Inputs Ch.3 [▶ 115]</a>
1A03	<a href="#">I/O TxPDO-Map Inputs Ch.4 [▶ 115]</a>
1A80	<a href="#">DeviceState TxPDO-Map Inputs [▶ 115]</a>
1A81	<a href="#">DeviceState TxPDO-Map Inputs [▶ 115]</a>
1C00	<a href="#">Sync Manager type [▶ 116]</a>
1C12	<a href="#">RxPDO assign [▶ 116]</a>
1C13	<a href="#">TxPDO assign [▶ 116]</a>
1C32	<a href="#">SM output parameter [▶ 117]</a>
1C33	<a href="#">SM input parameter [▶ 118]</a>
8000	<a href="#">I/O Settings Ch.1 [▶ 108]</a>
8010	<a href="#">I/O Settings Ch.2 [▶ 108]</a>
8020	<a href="#">I/O Settings Ch.3 [▶ 108]</a>
8030	<a href="#">I/O Settings Ch.4 [▶ 108]</a>
9000	<a href="#">I/O Info data Ch.1 [▶ 110]</a>
9010	<a href="#">I/O Info data Ch.2 [▶ 110]</a>
9020	<a href="#">I/O Info data Ch.3 [▶ 110]</a>
9030	<a href="#">I/O Info data Ch.4 [▶ 110]</a>
A000	<a href="#">I/O Diag data Ch.1 [▶ 111]</a>
A010	<a href="#">I/O Diag data Ch.2 [▶ 111]</a>
A020	<a href="#">I/O Diag data Ch.3 [▶ 111]</a>
A030	<a href="#">I/O Diag data Ch.4 [▶ 111]</a>
F000	<a href="#">Modular device profile [▶ 118]</a>
F008	<a href="#">Code word [▶ 118]</a>
F010	<a href="#">Module list [▶ 119]</a>
F100	<a href="#">Diagnosis Status data [▶ 111]</a>
F101	<a href="#">DeviceState Status data [▶ 111]</a>
F820	<a href="#">ADS Server Settings [▶ 109]</a>
F900	<a href="#">Info data [▶ 112]</a>

## 9.2.1 Configuration objects

### 800n IO Settings Ch.x

- 8000: IO Settings Ch.1
- 8001: IO Settings Ch.2
- 8002: IO Settings Ch.3
- 8003: IO Settings Ch.4

#### **Recommendation: Configuration via configuration tool**

**I** TwinCAT includes a graphical configuration tool for IO-Link masters and IO-Link devices. With this tool the configuration is easier and clearer than via the CoE parameters.

See chapter [Configuration of the IO link master \[► 53\]](#).

Subindex (hex)	Name	Meaning	Data Type	Flags	Default																				
0	IO Settings Ch.x		USINT	RO	0x28 (40 <sub>dec</sub> )																				
04	Device ID	The Device ID is used for validating the IO-Link device.	UDINT	RW	-																				
05	Vendor ID	The Vendor ID is used for validating the vendor of the IO-Link device.	UDINT	RW	-																				
20	IO-Link Revision	The version of the IO-Link specification according to which the IO-Link device communicates. Bit 0-3: MinorRev Bit 4-7: MajorRev	USINT	RW	-																				
21	Frame capability	Frame capability indicates certain functionalities of the IO-Link device (e.g. SPDU supported). Bit 0: SPDU Bit 1: Type1 Bit 7: PHY1	USINT	RW	-																				
22	Min cycle time	The cycle time at which the IO-Link master should communicate with the IO-Link device. This value is transferred in the IO-Link format for Min Cycle Time. Bit 6 and 7: Time Base Bit 0 to 5: Multiplier 0x00: The IO-Link master automatically uses the smallest possible update time of the IO-Link device.	USINT	RW	-																				
		<table border="1"> <thead> <tr> <th>Time Base</th> <th>Meaning Time base</th> <th>Calculation</th> <th>Min. Cycle Time</th> </tr> </thead> <tbody> <tr> <td>00<sub>bin</sub></td> <td>0.1ms</td> <td>Multiplier x Time Base</td> <td>0.4 - 6.3 ms</td> </tr> <tr> <td>01<sub>bin</sub></td> <td>0.4ms</td> <td>6.4 ms + Multiplier x Time Base</td> <td>6.4 - 31.6 ms</td> </tr> <tr> <td>10<sub>bin</sub></td> <td>1.6ms</td> <td>32.0 ms + Multiplier x Time Base</td> <td>32.0 - 132.8 ms</td> </tr> <tr> <td>11<sub>bin</sub></td> <td>6.4 ms</td> <td>134.4 ms + Multiplier x Time Base</td> <td>134.4 - 537.6 ms</td> </tr> </tbody> </table>	Time Base	Meaning Time base	Calculation	Min. Cycle Time	00 <sub>bin</sub>	0.1ms	Multiplier x Time Base	0.4 - 6.3 ms	01 <sub>bin</sub>	0.4ms	6.4 ms + Multiplier x Time Base	6.4 - 31.6 ms	10 <sub>bin</sub>	1.6ms	32.0 ms + Multiplier x Time Base	32.0 - 132.8 ms	11 <sub>bin</sub>	6.4 ms	134.4 ms + Multiplier x Time Base	134.4 - 537.6 ms			
Time Base	Meaning Time base	Calculation	Min. Cycle Time																						
00 <sub>bin</sub>	0.1ms	Multiplier x Time Base	0.4 - 6.3 ms																						
01 <sub>bin</sub>	0.4ms	6.4 ms + Multiplier x Time Base	6.4 - 31.6 ms																						
10 <sub>bin</sub>	1.6ms	32.0 ms + Multiplier x Time Base	32.0 - 132.8 ms																						
11 <sub>bin</sub>	6.4 ms	134.4 ms + Multiplier x Time Base	134.4 - 537.6 ms																						
23	Offset time	reserved	USINT	RW	-																				

Subindex (hex)	Name	Meaning	Data Type	Flags	Default
24	Process data in length	These parameters are transferred in the IO-Link format for "Process data in length".  Bit 7: BYTE (indicates whether the value in LENGTH is interpreted as bit length [bit not set] or as byte length + 1 [bit set])  Bit 6: SIO (indicates whether the device supports the standard I/O mode [bit set])  Bit 0 to 4: LENGTH (Length of the process data)	USINT	RW	-
25	Process data out length	These parameters are transferred in the IO-Link format for "Process data out length".  Bit 7: BYTE (indicates whether the value in LENGTH is interpreted as bit length [bit not set] or as byte length + 1 [bit set])  Bit 6: SIO (indicates whether the device supports the standard I/O mode [bit set])  Bit 0 to 4: LENGTH (Length of the process data)	USINT	RW	-
26	Compatible ID	reserved	UINT	RW	-
27	Reserved	reserved	UINT	RW	-
28	Master Control	Possible values: <ul style="list-style-type: none"><li>• 0: IO-Link port inactive</li><li>• 1: IO-Link port as digital input</li><li>• 2: IO-Link port as digital output</li><li>• 3: IO-Link port in communication via the IO-Link protocol.</li></ul> 4: IO-Link port in communication via the IO-Link protocol. The IO-Link state is ComStop (no cyclic communication, data is only exchanged when required).	UINT	RW	-

**F820 ADS Server Settings**

Index (hex)	Name	Meaning	Data Type	Flags	Default
F820:0	ADS Server Settings		USINT	RO	0x2 (2 <sub>dec</sub> )
F820:01	Net ID	NetId and port to which the DiagHistory messages can be sent via emergency	ARRAY [0..5] OF BYTE	RW	-
F820:02	Port		UINT	RW	-

## 9.2.2 Information objects

### 90n0 IO Info data Ch.x

- 9000: IO Info data Ch.1
- 9010: IO Info data Ch.2
- 9020: IO Info data Ch.3
- 9030: IO Info data Ch.4

Subindex (hex)	Name	Meaning	Data Type	Flags	Default																				
0	IO Info data Ch.x		USINT	RO	0x27 (39 <sub>dec</sub> )																				
04	Device ID	The device ID is used for validating the IO-Link device.	UDINT	RO	-																				
05	Vendor ID	The vendor ID is used for validating the manufacturer of the IO-Link device.	UDINT	RO	-																				
20	IO-Link Revision	ID of the specification version based on which the IO-Link device communicates. Bit 0-3: MinorRev Bit 4-7: MajorRev	USINT	RO	-																				
21	Frame capability	The Frame Capability indicates certain functionalities of the IO-Link device (e.g. SPDU supported). Bit 0: SPDU Bit 1: Type1 Bit 7: PHY1	USINT	RO	-																				
22	Min cycle time	The cycle time refers to the communication between the IO-Link master and the IO-Link device. This value is transferred in the IO-Link format for Min Cycle Time. Bit 6 and 7: Time Base Bit 0 to 5: Multiplier <table border="1" data-bbox="571 1102 1054 1496"> <thead> <tr> <th>Time Base</th> <th>Meaning Time base</th> <th>Calculation</th> <th>Min. Cycle Time</th> </tr> </thead> <tbody> <tr> <td>00b</td> <td>0,100 ms</td> <td>Multiplier x Time Base</td> <td>0,000 - 6,300 ms</td> </tr> <tr> <td>01b</td> <td>0,400 ms</td> <td>6,400 ms + Multiplier x Time Base</td> <td>6,400 - 31,600 ms</td> </tr> <tr> <td>10b</td> <td>1,600 ms</td> <td>32,000 ms + Multiplier x Time Base</td> <td>32,000 - 132,800 ms</td> </tr> <tr> <td>11b</td> <td>6,400 ms</td> <td>134,400 ms + Multiplier x Time Base</td> <td>134,400 - 537,600 ms</td> </tr> </tbody> </table>	Time Base	Meaning Time base	Calculation	Min. Cycle Time	00b	0,100 ms	Multiplier x Time Base	0,000 - 6,300 ms	01b	0,400 ms	6,400 ms + Multiplier x Time Base	6,400 - 31,600 ms	10b	1,600 ms	32,000 ms + Multiplier x Time Base	32,000 - 132,800 ms	11b	6,400 ms	134,400 ms + Multiplier x Time Base	134,400 - 537,600 ms	USINT	RO	-
Time Base	Meaning Time base	Calculation	Min. Cycle Time																						
00b	0,100 ms	Multiplier x Time Base	0,000 - 6,300 ms																						
01b	0,400 ms	6,400 ms + Multiplier x Time Base	6,400 - 31,600 ms																						
10b	1,600 ms	32,000 ms + Multiplier x Time Base	32,000 - 132,800 ms																						
11b	6,400 ms	134,400 ms + Multiplier x Time Base	134,400 - 537,600 ms																						
23	Offset time	reserved	USINT	RO	-																				
24	Process data in length	These parameters are transferred in the IO-Link format for "Process data in length". Bit 7: BYTE (indicates whether the value in LENGTH is interpreted as bit length [bit not set] or as byte length + 1 [bit set]) Bit 6: SIO (indicates whether the device supports the standard I/O mode [bit set]) Bit 0 to 4: LENGTH (Length of the process data)	USINT	RO	-																				

Subindex (hex)	Name	Meaning	Data Type	Flags	Default
25	Process data out length	These parameters are transferred in the IO-Link format for "Process data out length".  Bit 7: BYTE (indicates whether the value in LENGTH is interpreted as bit length [bit not set] or as byte length + 1 [bit set])  Bit 6: SIO (indicates whether the device supports the standard I/O mode [bit set])  Bit 0 to 4: LENGTH (Length of the process data)	USINT	RO	-
26	Reserved	reserved	UINT	RO	-
27	Reserved2	reserved	UINT	RO	-

**A0n0 IO Diag data Ch.x**

- A000: IO Info data Ch.1
- A010: IO Info data Ch.2
- A020: IO Info data Ch.3
- A030: IO Info data Ch.4

Index (hex)	Name	Meaning	Data Type	Flags	Default
A000:0	IO Diag data Ch.x		USINT	RO	0x2 (2 <sub>dec</sub> )
A000:01	IO-Link State	The value of the IO-Link state corresponds to a state from the IO-Link master state machine  0: INACTIVE 1: DIGINPUT 2: DIGOUTPUT 3: ESTABLISHCOMM 4: INITMASTER 5: INITDEVICE  7: PREOPERATE 8: OPERATE 9: STOP	USINT	RO	-
A000:02	Lost Frames	This parameter counts the number of lost IO-Link telegrams. This value is deleted whenever IO-Link starts up, otherwise it is incremented continuously.	USINT	RO	-

**F100 Diagnosis Status data**

See chapter [Status of the IO-Link ports \[► 88\]](#).

Index (hex)	Name	Meaning	Data Type	Flags	Default
F100:0	Diagnosis Status data		USINT	RO	0x4 (4 <sub>dec</sub> )
F100:01	State Ch1	IO-Link Status byte Ch. 1	USINT	RO	-
F100:02	State Ch2	IO-Link Status byte Ch. 2	USINT	RO	-
F100:03	State Ch3	IO-Link Status byte Ch. 3	USINT	RO	-
F100:04	State Ch4	IO-Link Status byte Ch. 4	USINT	RO	-

**F101 DeviceState Status data**

Index (hex)	Name	Meaning	Data Type	Flags	Default
F101:0	DeviceState Status data		USINT	RO	0x10 (16 <sub>dec</sub> )
F101:0D	Device Diag	-	BOOL	RO	-
F101:10	Device State	-	BOOL	RO	-

**F900 Info data**

Index (hex)	Name	Meaning	Data Type	Flags	Default
F900:0	Info data		USINT	RO	0x1 (1 <sub>dec</sub> )
F900:01	IO-Link Version	-	USINT	RO	-

## 9.2.3 Standard objects

### 1000 Device type

Index (hex)	Name	Meaning	Data Type	Flags	Default
1000:0	Device type	Device type of the EtherCAT slave: the Lo-Word contains the used CoE profile (5001). The Hi-Word contains the module profile according to the modular device profile.	UDINT	RO	0x89134C18 (2299743256 <sub>dec</sub> )

### 1008 Device name

Index (hex)	Name	Meaning	Data Type	Flags	Default
1008:0	Device name	Device name of the EtherCAT slave	STRING(12)	RO	EPP6224-052 2

### 1009 Hardware version

Index (hex)	Name	Meaning	Data Type	Flags	Default
1009:0	Hardware version	Hardware version of the EtherCAT slave	STRING(2)	RO	-

### 100A Software version

Index (hex)	Name	Meaning	Data Type	Flags	Default
100A:0	Software version	Firmware version of the EtherCAT slave	STRING(2)	RO	-

### 1010 Store parameters

Index (hex)	Name	Meaning	Data Type	Flags	Default
1010:0	Store parameters		USINT	RO	0x1 (1 <sub>dec</sub> )

### 1011 Restore default parameters

Index (hex)	Name	Meaning	Data Type	Flags	Default
1011:0	Restore default parameters	Restoring the default parameters	USINT	RO	0x1 (1 <sub>dec</sub> )
1011:01	SubIndex 001	If this object is set to "0x64616F6C" in the set value dialog, all backup objects are reset to their delivery state.	UINT32	RW	0x00000000 (0 <sub>dec</sub> )

### 1018 Identity

Index (hex)	Name	Meaning	Data Type	Flags	Default
1018:0	Identity	Information for identifying the slave	USINT	RO	0x4 (4 <sub>dec</sub> )
1018:01	Vendor ID	Vendor ID of the EtherCAT slave	UDINT	RO	0x2 (2 <sub>dec</sub> )
1018:02	Product code	Product code of the EtherCAT slave	UDINT	RO	0x94B7764 (155940708 <sub>dec</sub> )
1018:03	Revision	Revision number of the EtherCAT slave; the low word (bit 0-15) indicates the special terminal number, the high word (bit 16-31) refers to the device description	UDINT	RO	-
1018:04	Serial number	Serial number of the EtherCAT slave; the low byte (bit 0-7) of the low word contains the year of production, the high byte (bit 8-15) of the low word contains the week of production, the high word (bit 16-31) is 0	UDINT	RO	-

**10F0 Backup parameter handling**

Index (hex)	Name	Meaning	Data Type	Flags	Default
10F0:0	Backup parameter handling	Information for standardized loading and saving of backup entries	USINT	RO	0x1 (1 <sub>dec</sub> )
10F0:01	Checksum	Checksum across all backup entries of the EtherCAT slave	UDINT	RO	-

**10F2 Backup parameter storage**

Index (hex)	Name	Meaning	Data Type	Flags	Default
10F2:0	Backup parameter storage	-	ARRAY [0..3] OF BYTE	RO	-

**10F3 Diagnosis History**

Index (hex)	Name	Meaning	Data Type	Flags	Default
10F3:0	Diagnosis History	Maximum subindex	USINT	RO	0x15 (21 <sub>dec</sub> )
10F3:01	Maximum Messages	Maximum number of stored messages A maximum of 16 messages can be saved	USINT	RO	-
10F3:02	Newest Message	Subindex of the latest message	USINT	RO	-
10F3:03	Newest Acknowledged Message	Subindex of the last acknowledged message	USINT	RW	-
10F3:04	New Messages Available	Indicates that a new message is available	BOOL	RO	-
10F3:05	Flags		UINT	RW	-
10F3:06	Diagnosis Message 001	Message 1	ARRAY [0..27] OF BYTE	RO	-
10F3:07	Diagnosis Message 002	Message 2	ARRAY [0..27] OF BYTE	RO	-
10F3:08	Diagnosis Message 003	Message 3	ARRAY [0..27] OF BYTE	RO	-
...	...	...	...	...	...
10F3:13	Diagnosis Message 014	Message 14	ARRAY [0..27] OF BYTE	RO	-
10F3:14	Diagnosis Message 015	Message 15	ARRAY [0..27] OF BYTE	RO	-
10F3:15	Diagnosis Message 016	Message 16	ARRAY [0..27] OF BYTE	RO	-

**10F8 Actual Time Stamp**

Index (hex)	Name	Meaning	Data Type	Flags	Default
10F8:0	Actual Time Stamp	-	ULINT	RO	-

**160n IO RxPDO-Map Outputs Ch.x**

- 1600: IO Settings Ch.1
- 1601: IO Settings Ch.2
- 1602: IO Settings Ch.3
- 1603: IO Settings Ch.4

Subindex (hex)	Name	Meaning	Data Type	Flags	Default
0	IO RxPDO-Map Outputs Ch.x	-	USINT	RO	-
01	SubIndex 001		UDINT	RW	0x0000:00, 0
02	SubIndex 002		UDINT	RW	0x0000:00, 0
03	SubIndex 003		UDINT	RW	0x0000:00, 0
04	SubIndex 004		UDINT	RW	0x0000:00, 0
...	...	...	...	...	...
3E	SubIndex 062		UDINT	RW	0x0000:00, 0
3F	SubIndex 063		UDINT	RW	0x0000:00, 0
40	SubIndex 064		UDINT	RW	0x0000:00, 0

**1A0n IO TxPDO-Map Inputs Ch.x**

- 1A00: TxPDO-Map Inputs Ch.1
- 1A01: TxPDO-Map Inputs Ch.2
- 1A02: TxPDO-Map Inputs Ch.3
- 1A03: TxPDO-Map Inputs Ch.4

Index (hex)	Name	Meaning	Data Type	Flags	Default
1A00:0	IO TxPDO-Map Inputs Ch.1	-	USINT	RO	-
1A00:01	SubIndex 001		UDINT	RW	0x0000:00, 0
1A00:02	SubIndex 002		UDINT	RW	0x0000:00, 0
1A00:03	SubIndex 003		UDINT	RW	0x0000:00, 0
...	...	...	...	...	...
1A00:3E	SubIndex 062		UDINT	RW	0x0000:00, 0
1A00:3F	SubIndex 063		UDINT	RW	0x0000:00, 0
1A00:40	SubIndex 064		UDINT	RW	0x0000:00, 0

**1A80 DeviceState TxPDO-Map Inputs**

Index (hex)	Name	Meaning	Data Type	Flags	Default
1A80:0	DeviceState TxPDO-Map Inputs		USINT	RO	0x4 (4 <sub>dec</sub> )
1A80:01	SubIndex 001	PDO Mapping Entry for "State Ch1".	UDINT	RO	0xf100:01, 8
1A80:02	SubIndex 002	PDO Mapping Entry for "State Ch2".	UDINT	RO	0xf100:02, 8
1A80:03	SubIndex 003	PDO Mapping Entry for "State Ch3".	UDINT	RO	0xf100:03, 8
1A80:04	SubIndex 004	PDO Mapping Entry for "State Ch4".	UDINT	RO	0xf100:04, 8

**1A81 DeviceState TxPDO-Map Inputs**

Index (hex)	Name	Meaning	Data Type	Flags	Default
1A81:0	DeviceState TxPDO-Map Inputs		USINT	RO	0x4 (4 <sub>dec</sub> )
1A81:01	SubIndex 001		UDINT	RO	0x0000:00, 12
1A81:02	SubIndex 002	PDO Mapping Entry for "Device Diag".	UDINT	RO	0xf101:0d, 1
1A81:03	SubIndex 003		UDINT	RO	0x0000:00, 2
1A81:04	SubIndex 004	PDO Mapping Entry for "Device State".	UDINT	RO	0xf101:10, 1

**1C00 Sync manager type**

Index (hex)	Name	Meaning	Data Type	Flags	Default
1C00:0	Sync manager type		USINT	RO	0x4 (4 <sub>dec</sub> )
1C00:01	SubIndex 001	Sync Manager Type Channel 1: Mailbox Write	USINT	RO	0x1 (1 <sub>dec</sub> )
1C00:02	SubIndex 002	Sync Manager Type Channel 2: Mailbox Read	USINT	RO	0x2 (2 <sub>dec</sub> )
1C00:03	SubIndex 003	Sync Manager Type Channel 3: Process Data Write (Outputs)	USINT	RO	0x3 (3 <sub>dec</sub> )
1C00:04	SubIndex 004	Sync Manager Type Channel 4: Process Data Read (Inputs)	USINT	RO	0x4 (4 <sub>dec</sub> )
1C00:05	SubIndex 005		USINT	RO	0x3 (3 <sub>dec</sub> )

**1C12 RxPDO assign**

Index (hex)	Name	Meaning	Data Type	Flags	Default
1C12:0	RxPDO assign		USINT	RO	0x4 (4 <sub>dec</sub> )
1C12:01	SubIndex 001		UINT	RW	0x16 (22 <sub>dec</sub> )
1C12:02	SubIndex 002		UINT	RW	0x116 (278 <sub>dec</sub> )
1C12:03	SubIndex 003		UINT	RW	0x216 (534 <sub>dec</sub> )
1C12:04	SubIndex 004		UINT	RW	0x316 (790 <sub>dec</sub> )

**1C13 TxPDO assign**

Index (hex)	Name	Meaning	Data Type	Flags	Default
1C13:0	TxPDO assign		USINT	RO	0x6 (6 <sub>dec</sub> )
1C13:01	SubIndex 001		UINT	RW	0x1A (26 <sub>dec</sub> )
1C13:02	SubIndex 002		UINT	RW	0x11A (282 <sub>dec</sub> )
1C13:03	SubIndex 003		UINT	RW	0x21A (538 <sub>dec</sub> )
1C13:04	SubIndex 004		UINT	RW	0x31A (794 <sub>dec</sub> )
1C13:05	SubIndex 005		UINT	RW	0x801A (32794 <sub>dec</sub> )
1C13:06	SubIndex 006		UINT	RW	0x811A (33050 <sub>dec</sub> )

**1C32 SM output parameter**

Index (hex)	Name	Meaning	Data Type	Flags	Default
1C32:0	SM output parameter	Synchronization parameters for the outputs	USINT	RO	0x20 (32 <sub>dec</sub> )
1C32:01	Sync mode	Current synchronization mode: 0: Free Run 1: Synchronous with SM 2 Event 2: DC-Mode - synchronous with SYNC0 Event 3: DC-Mode - synchronous with SYNC1 Event	UINT	RW	0x1 (1 <sub>dec</sub> )
1C32:02	Cycle time	Cycle time (in ns): Free Run: cycle time of the local timer Synchronous with SM 2 Event: cycle time of the master DC-Mode: SYNC0/SYNC1 Cycle Time	UDINT	RW	0x7A120 (500000 <sub>dec</sub> )
1C32:03	Shift time	Time between SYNC0 event and output of the outputs (in ns, DC mode only)	UDINT	RO	0x0 (0 <sub>dec</sub> )
1C32:04	Sync modes supported	Sync modes supported: Bit 0 = 1: Free Run is supported Bit 1 = 1: Synchronization with SM 2 Event is supported Bit 2-3 = 01: DC-Mode is supported Bit 4-5 = 10: Output Shift with SYNC1 Event (DC mode only) Bit 14 = 1: dynamic times (measurement through writing of 1C32:08)	UINT	RO	0x3 (3 <sub>dec</sub> )
1C32:05	Minimum cycle time	Minimum cycle time (in ns)	UDINT	RO	0x186A0 (100000 <sub>dec</sub> )
1C32:06	Calc and copy time	Minimum time between SYNC0 and SYNC1 event (in ns, DC Mode only)	UDINT	RO	0x0 (0 <sub>dec</sub> )
1C32:07	Minimum delay time		UDINT	RO	0x0 (0 <sub>dec</sub> )
1C32:08	Command	0: Measurement of the local cycle time is stopped 1: Measurement of the local cycle time is started The entries 1C32:03, 1C32:05, 1C32:06, 1C32:09, 1C33:03, 1C33:06, 1C33:09 are updated with the maximum measured values. For a subsequent measurement the measured values are reset	UINT	RW	0x0 (0 <sub>dec</sub> )
1C32:09	Maximum delay time	Time between SYNC1 event and output of the outputs (in ns, DC mode only)	UDINT	RO	0x0 (0 <sub>dec</sub> )
1C32:0B	SM event missed counter	Number of missed SM events in OPERATIONAL (DC Mode only)	UINT	RO	-
1C32:0C	Cycle exceeded counter	Number of occasions the cycle time was exceeded in OPERATIONAL (cycle was not completed in time or the next cycle began too early)	UINT	RO	-
1C32:0D	Shift too short counter	Number of intervals between SYNC0 and SYNC1 events that are too short (DC Mode only)	UINT	RO	-
1C32:20	Sync error	The synchronization was not correct in the last cycle (outputs were output too late; DC Mode only)	BOOL	RO	-

**1C33 SM input parameter**

Index (hex)	Name	Meaning	Data Type	Flags	Default
1C33:0	SM input parameter	Synchronization parameters for the inputs	USINT	RO	0x20 (32 <sub>dec</sub> )
1C33:01	Sync mode	Current synchronization mode: 0: Free Run 1: Synchronous with SM 3 Event (no outputs available) 2: DC - Synchronous with SYNC0 Event 3: DC - Synchronous with SYNC1 Event 34: Synchronous with SM 2 Event (outputs available)	UINT	RW	0x22 (34 <sub>dec</sub> )
1C33:02	Cycle time	as 1C32:02	UDINT	RW	0x7A120 (500000 <sub>dec</sub> )
1C33:03	Shift time	Time between SYNC0 event and reading of the inputs (in ns, DC Mode only)	UDINT	RO	0x0 (0 <sub>dec</sub> )
1C33:04	Sync modes supported	Sync modes supported: Bit 0: Free Run is supported Bit 1: Synchronization with SM 2 Event is supported (outputs available) Bit 1: Synchronization with SM 3 Event is supported (no outputs available) Bit 2-3 = 01: DC-Mode is supported Bit 4-5 = 01: Input shift through local event (outputs available) Bit 4-5 = 10: Input shift with SYNC1 event (no outputs available) Bit 14 = 1: dynamic times (measurement through writing of 1C32:08 or 1C33:08)	UINT	RO	0x3 (3 <sub>dec</sub> )
1C33:05	Minimum cycle time	as 1C32:05	UDINT	RO	0x186A0 (100000 <sub>dec</sub> )
1C33:06	Calc and copy time	Time between reading of the inputs and the inputs being available for the master (in ns, DC Mode only)	UDINT	RO	0x0 (0 <sub>dec</sub> )
1C33:07	Minimum delay time		UDINT	RO	0x0 (0 <sub>dec</sub> )
1C33:08	Command	as 1C32:08	UINT	RW	0x0 (0 <sub>dec</sub> )
1C33:09	Maximum delay time	Time between SYNC1 event and reading of the inputs (in ns, DC Mode only)	UDINT	RO	0x0 (0 <sub>dec</sub> )
1C33:0B	SM event missed counter	as 1C32:11	UINT	RO	-
1C33:0C	Cycle exceeded counter	as 1C32:12	UINT	RO	-
1C33:0D	Shift too short counter	as 1C32:13	UINT	RO	-
1C33:20	Sync error	as 1C32:32	BOOL	RO	-

**F000 Modular device profile**

Index (hex)	Name	Meaning	Data Type	Flags	Default
F000:0	Modular device profile		USINT	RO	0x2 (2 <sub>dec</sub> )
F000:01	Module index distance		UINT	RO	0x10 (16 <sub>dec</sub> )
F000:02	Maximum number of modules		UINT	RO	0x8 (8 <sub>dec</sub> )

**F008 Code word**

Index (hex)	Name	Meaning	Data Type	Flags	Default
F008:0	Code word	-	UDINT	RO	-

**F010 Module list**

Index (hex)	Name	Meaning	Data Type	Flags	Default
F010:0	Module list		USINT	RO	0x4 (4 <sub>dec</sub> )
F010:01	SubIndex 001		UDINT	RO	0x4C180000 (1276641280 <sub>d</sub> ec)
F010:02	SubIndex 002		UDINT	RO	0x4C180000 (1276641280 <sub>d</sub> ec)
F010:03	SubIndex 003		UDINT	RO	0x4C180000 (1276641280 <sub>d</sub> ec)
F010:04	SubIndex 004		UDINT	RO	0x4C180000 (1276641280 <sub>d</sub> ec)

## 9.3 EPP6228-0022

Index (hex)	Name
1000	<a href="#">Device type [▶ 127]</a>
1008	<a href="#">Device name [▶ 127]</a>
1009	<a href="#">Hardware version [▶ 127]</a>
100A	<a href="#">Software version [▶ 127]</a>
1010	<a href="#">Store parameters [▶ 127]</a>
1011	<a href="#">Restore default parameters [▶ 127]</a>
1018	<a href="#">Identity [▶ 127]</a>
10F0	<a href="#">Backup parameter handling [▶ 128]</a>
10F2	<a href="#">Backup parameter storage [▶ 128]</a>
10F3	<a href="#">Diagnosis History [▶ 128]</a>
10F8	<a href="#">Actual Time Stamp [▶ 128]</a>
1600	<a href="#">I/O RxPDO-Map Outputs Ch.1 [▶ 128]</a>
1601	<a href="#">I/O RxPDO-Map Outputs Ch.2 [▶ 128]</a>
1602	<a href="#">I/O RxPDO-Map Outputs Ch.3 [▶ 128]</a>
1603	<a href="#">I/O RxPDO-Map Outputs Ch.4 [▶ 128]</a>
1604	<a href="#">I/O RxPDO-Map Outputs Ch.5 [▶ 128]</a>
1605	<a href="#">I/O RxPDO-Map Outputs Ch.6 [▶ 128]</a>
1606	<a href="#">I/O RxPDO-Map Outputs Ch.7 [▶ 128]</a>
1607	<a href="#">I/O RxPDO-Map Outputs Ch.8 [▶ 128]</a>
1A00	<a href="#">I/O TxPDO-Map Inputs Ch.1 [▶ 128]</a>
1A01	<a href="#">I/O TxPDO-Map Inputs Ch.2 [▶ 128]</a>
1A02	<a href="#">I/O TxPDO-Map Inputs Ch.3 [▶ 128]</a>
1A03	<a href="#">I/O TxPDO-Map Inputs Ch.4 [▶ 128]</a>
1A04	<a href="#">I/O TxPDO-Map Inputs Ch.5 [▶ 128]</a>
1A05	<a href="#">I/O TxPDO-Map Inputs Ch.6 [▶ 128]</a>
1A06	<a href="#">I/O TxPDO-Map Inputs Ch.7 [▶ 128]</a>
1A07	<a href="#">I/O TxPDO-Map Inputs Ch.8 [▶ 128]</a>
1A20	<a href="#">Digital TxPDO-Map Inputs [▶ 129]</a>
1A80	<a href="#">DeviceState TxPDO-Map Inputs [▶ 129]</a>
1A81	<a href="#">DeviceState TxPDO-Map Inputs [▶ 129]</a>
1C00	<a href="#">Sync Manager type [▶ 130]</a>
1C12	<a href="#">RxPDO assign [▶ 130]</a>
1C13	<a href="#">TxPDO assign [▶ 130]</a>
1C32	<a href="#">SM output parameter [▶ 131]</a>
1C33	<a href="#">SM input parameter [▶ 132]</a>
8000	<a href="#">I/O Settings Ch.1 [▶ 122]</a>
8010	<a href="#">I/O Settings Ch.2 [▶ 122]</a>
8020	<a href="#">I/O Settings Ch.3 [▶ 122]</a>
8030	<a href="#">I/O Settings Ch.4 [▶ 122]</a>
8040	<a href="#">I/O Settings Ch.5 [▶ 122]</a>
8050	<a href="#">I/O Settings Ch.6 [▶ 122]</a>
8060	<a href="#">I/O Settings Ch.7 [▶ 122]</a>
8070	<a href="#">I/O Settings Ch.8 [▶ 122]</a>
9000	<a href="#">I/O Info data Ch.1 [▶ 124]</a>
9010	<a href="#">I/O Info data Ch.2 [▶ 124]</a>
9020	<a href="#">I/O Info data Ch.3 [▶ 124]</a>
9030	<a href="#">I/O Info data Ch.4 [▶ 124]</a>
9040	<a href="#">I/O Info data Ch.5 [▶ 124]</a>
9050	<a href="#">I/O Info data Ch.6 [▶ 124]</a>
9060	<a href="#">I/O Info data Ch.7 [▶ 124]</a>

Index (hex)	Name
9070	I/O Info data Ch.8 [ <a href="#">▶ 124</a> ]
A000	I/O Diag data Ch.1 [ <a href="#">▶ 125</a> ]
A010	I/O Diag data Ch.2 [ <a href="#">▶ 125</a> ]
A020	I/O Diag data Ch.3 [ <a href="#">▶ 125</a> ]
A030	I/O Diag data Ch.4 [ <a href="#">▶ 125</a> ]
A040	I/O Diag data Ch.5 [ <a href="#">▶ 125</a> ]
A050	I/O Diag data Ch.6 [ <a href="#">▶ 125</a> ]
A060	I/O Diag data Ch.7 [ <a href="#">▶ 125</a> ]
A070	I/O Diag data Ch.8 [ <a href="#">▶ 125</a> ]
F000	Modular device profile [ <a href="#">▶ 132</a> ]
F008	Code word [ <a href="#">▶ 132</a> ]
F010	Module list [ <a href="#">▶ 133</a> ]
F100	Diagnosis Status data [ <a href="#">▶ 125</a> ]
F101	DeviceState Status data [ <a href="#">▶ 126</a> ]
F102	Digital InputPin2 [ <a href="#">▶ 126</a> ]
F820	ADS Server Settings [ <a href="#">▶ 123</a> ]
F900	Info data [ <a href="#">▶ 126</a> ]

## 9.3.1 Configuration objects

### 800n IO Settings Ch.x

- 8000: IO Settings Ch.1
- 8001: IO Settings Ch.2
- 8002: IO Settings Ch.3
- ...
- 8007: IO Settings Ch.8

#### **● Recommendation: Configuration via configuration tool**

**I** TwinCAT includes a graphical configuration tool for IO-Link masters and IO-Link devices. With this tool the configuration is easier and clearer than via the CoE parameters.

See chapter [Configuration of the IO link master \[► 53\]](#).

Subindex (hex)	Name	Meaning	Data Type	Flags	Default																				
0	IO Settings Ch.x		USINT	RO	0x28 (40 <sub>dec</sub> )																				
04	Device ID	The Device ID is used for validating the IO-Link device.	UDINT	RW	-																				
05	Vendor ID	The Vendor ID is used for validating the vendor of the IO-Link device.	UDINT	RW	-																				
20	IO-Link Revision	The version of the IO-Link specification according to which the IO-Link device communicates. Bit 0-3: MinorRev Bit 4-7: MajorRev	USINT	RW	-																				
21	Frame capability	Frame capability indicates certain functionalities of the IO-Link device (e.g. SPDU supported). Bit 0: SPDU Bit 1: Type1 Bit 7: PHY1	USINT	RW	-																				
22	Min cycle time	The cycle time at which the IO-Link master should communicate with the IO-Link device. This value is transferred in the IO-Link format for Min Cycle Time. Bit 6 and 7: Time Base Bit 0 to 5: Multiplier 0x00: The IO-Link master automatically uses the smallest possible update time of the IO-Link device.	USINT	RW	-																				
		<table border="1"> <thead> <tr> <th>Time Base</th> <th>Meaning Time base</th> <th>Calculation</th> <th>Min. Cycle Time</th> </tr> </thead> <tbody> <tr> <td>00<sub>bin</sub></td> <td>0.1ms</td> <td>Multiplier x Time Base</td> <td>0.4- 6.3 ms</td> </tr> <tr> <td>01<sub>bin</sub></td> <td>0.4ms</td> <td>6.4 ms + Multiplier x Time Base</td> <td>6.4- 31.6 ms</td> </tr> <tr> <td>10<sub>bin</sub></td> <td>1.6ms</td> <td>32.0 ms + Multiplier x Time Base</td> <td>32.0 - 132.8 ms</td> </tr> <tr> <td>11<sub>bin</sub></td> <td>6.4 ms</td> <td>134.4 ms + Multiplier x Time Base</td> <td>134.4- 537.6 ms</td> </tr> </tbody> </table>	Time Base	Meaning Time base	Calculation	Min. Cycle Time	00 <sub>bin</sub>	0.1ms	Multiplier x Time Base	0.4- 6.3 ms	01 <sub>bin</sub>	0.4ms	6.4 ms + Multiplier x Time Base	6.4- 31.6 ms	10 <sub>bin</sub>	1.6ms	32.0 ms + Multiplier x Time Base	32.0 - 132.8 ms	11 <sub>bin</sub>	6.4 ms	134.4 ms + Multiplier x Time Base	134.4- 537.6 ms			
Time Base	Meaning Time base	Calculation	Min. Cycle Time																						
00 <sub>bin</sub>	0.1ms	Multiplier x Time Base	0.4- 6.3 ms																						
01 <sub>bin</sub>	0.4ms	6.4 ms + Multiplier x Time Base	6.4- 31.6 ms																						
10 <sub>bin</sub>	1.6ms	32.0 ms + Multiplier x Time Base	32.0 - 132.8 ms																						
11 <sub>bin</sub>	6.4 ms	134.4 ms + Multiplier x Time Base	134.4- 537.6 ms																						
23	Offset time	reserved	USINT	RW	-																				

Subindex (hex)	Name	Meaning	Data Type	Flags	Default
24	Process data in length	<p>These parameters are transferred in the IO-Link format for "Process data in length".</p> <p>Bit 7: BYTE (indicates whether the value in LENGTH is interpreted as bit length [bit not set] or as byte length + 1 [bit set])</p> <p>Bit 6: SIO (indicates whether the device supports the standard I/O mode [bit set])</p> <p>Bit 0 to 4: LENGTH (Length of the process data)</p>	USINT	RW	-
25	Process data out length	<p>These parameters are transferred in the IO-Link format for "Process data out length".</p> <p>Bit 7: BYTE (indicates whether the value in LENGTH is interpreted as bit length [bit not set] or as byte length + 1 [bit set])</p> <p>Bit 6: SIO (indicates whether the device supports the standard I/O mode [bit set])</p> <p>Bit 0 to 4: LENGTH (Length of the process data)</p>	USINT	RW	-
26	Compatible ID	reserved	UINT	RW	-
27	Reserved	reserved	UINT	RW	-
28	Master Control	<p>Possible values:</p> <ul style="list-style-type: none"> <li>• 0: IO-Link port inactive</li> <li>• 1: IO-Link port as digital input</li> <li>• 2: IO-Link port as digital output</li> <li>• 3: IO-Link port in communication via the IO-Link protocol.</li> <li>• 4: IO-Link port in communication via the IO-Link protocol. The IO-Link state is ComStop (no cyclic communication, data is only exchanged when required).</li> </ul>	UINT	RW	-

**F820 ADS Server Settings**

Index (hex)	Name	Meaning	Data Type	Flags	Default
F820:0	ADS Server Settings		USINT	RO	0x2 (2 <sub>dec</sub> )
F820:01	Net ID	NetId and port to which the DiagHistory messages can be sent via emergency	ARRAY [0..5] OF BYTE	RW	-
F820:02	Port		UINT	RW	-

## 9.3.2 Information objects

### 900n IO Info data Ch.x

- 9000: IO Info data Ch.1
- 9001: IO Info data Ch.2
- 9002: IO Info data Ch.3
- ...

Subindex (hex)	Name	Meaning	Data Type	Flags	Default																				
0	IO Info data Ch.x		USINT	RO	0x27 (39 <sub>dec</sub> )																				
04	Device ID	The device ID is used for validating the IO-Link device.	UDINT	RO	-																				
05	Vendor ID	The vendor ID is used for validating the manufacturer of the IO-Link device.	UDINT	RO	-																				
20	IO-Link Revision	ID of the specification version based on which the IO-Link device communicates. Bit 0-3: MinorRev Bit 4-7: MajorRev	USINT	RO	-																				
21	Frame capability	The Frame Capability indicates certain functionalities of the IO-Link device (e.g. SPDU supported). Bit 0: SPDU Bit 1: Type1 Bit 7: PHY1	USINT	RO	-																				
22	Min cycle time	The cycle time refers to the communication between the IO-Link master and the IO-Link device. This value is transferred in the IO-Link format for Min Cycle Time. Bit 6 and 7: Time Base Bit 0 to 5: Multiplier <table border="1" data-bbox="571 1102 1054 1496"> <thead> <tr> <th>Time Base</th> <th>Meaning Time base</th> <th>Calculation</th> <th>Min. Cycle Time</th> </tr> </thead> <tbody> <tr> <td>00b</td> <td>0,100 ms</td> <td>Multiplier x Time Base</td> <td>0,000 - 6,300 ms</td> </tr> <tr> <td>01b</td> <td>0,400 ms</td> <td>6,400 ms + Multiplier x Time Base</td> <td>6,400 - 31,600 ms</td> </tr> <tr> <td>10b</td> <td>1,600 ms</td> <td>32,000 ms + Multiplier x Time Base</td> <td>32,000 - 132,800 ms</td> </tr> <tr> <td>11b</td> <td>6,400 ms</td> <td>134,400 ms + Multiplier x Time Base</td> <td>134,400 - 537,600 ms</td> </tr> </tbody> </table>	Time Base	Meaning Time base	Calculation	Min. Cycle Time	00b	0,100 ms	Multiplier x Time Base	0,000 - 6,300 ms	01b	0,400 ms	6,400 ms + Multiplier x Time Base	6,400 - 31,600 ms	10b	1,600 ms	32,000 ms + Multiplier x Time Base	32,000 - 132,800 ms	11b	6,400 ms	134,400 ms + Multiplier x Time Base	134,400 - 537,600 ms	USINT	RO	-
Time Base	Meaning Time base	Calculation	Min. Cycle Time																						
00b	0,100 ms	Multiplier x Time Base	0,000 - 6,300 ms																						
01b	0,400 ms	6,400 ms + Multiplier x Time Base	6,400 - 31,600 ms																						
10b	1,600 ms	32,000 ms + Multiplier x Time Base	32,000 - 132,800 ms																						
11b	6,400 ms	134,400 ms + Multiplier x Time Base	134,400 - 537,600 ms																						
23	Offset time	reserved	USINT	RO	-																				
24	Process data in length	These parameters are transferred in the IO-Link format for "Process data in length". Bit 7: BYTE (indicates whether the value in LENGTH is interpreted as bit length [bit not set] or as byte length + 1 [bit set]) Bit 6: SIO (indicates whether the device supports the standard I/O mode [bit set]) Bit 0 to 4: LENGTH (Length of the process data)	USINT	RO	-																				

Subindex (hex)	Name	Meaning	Data Type	Flags	Default
25	Process data out length	These parameters are transferred in the IO-Link format for "Process data out length".  Bit 7: BYTE (indicates whether the value in LENGTH is interpreted as bit length [bit not set] or as byte length + 1 [bit set])  Bit 6: SIO (indicates whether the device supports the standard I/O mode [bit set])  Bit 0 to 4: LENGTH (Length of the process data)	USINT	RO	-
26	Reserved	reserved	UINT	RO	-
27	Reserved2	reserved	UINT	RO	-

**A0n0 IO Diag data Ch.x**

- A000: IO Diag data Ch.1
- A010: IO Diag data Ch.2
- A020: IO Diag data Ch.3
- ...

Subindex (hex)	Name	Meaning	Data Type	Flags	Default
0	IO Diag data Ch.x		USINT	RO	0x2 (2 <sub>dec</sub> )
01	IO-Link State	The value of the IO-Link state corresponds to a state from the IO-Link master state machine  0: INACTIVE 1: DIGINPUT 2: DIGOUTPUT 3: ESTABLISHCOMM 4: INITMASTER 5: INITDEVICE  7: PREOPERATE 8: OPERATE 9: STOP	USINT	RO	-
02	Lost Frames	This parameter counts the number of lost IO-Link telegrams. This value is deleted whenever IO-Link starts up, otherwise it is incremented continuously.	USINT	RO	-

**F100 Diagnosis Status data**

See chapter [Status of the IO-Link ports \[► 88\]](#).

Index (hex)	Name	Meaning	Data Type	Flags	Default
F100:0	Diagnosis Status data		USINT	RO	0x8 (8 <sub>dec</sub> )
F100:01	State Ch1	IO-Link Status byte Ch. 1	USINT	RO	-
F100:02	State Ch2	IO-Link Status byte Ch. 2	USINT	RO	-
F100:03	State Ch3	IO-Link Status byte Ch. 3	USINT	RO	-
F100:04	State Ch4	IO-Link Status byte Ch. 4	USINT	RO	-
F100:05	State Ch5	IO-Link Status byte Ch. 5	USINT	RO	-
F100:06	State Ch6	IO-Link Status byte Ch. 6	USINT	RO	-
F100:07	State Ch7	IO-Link Status byte Ch. 7	USINT	RO	-
F100:08	State Ch8	IO-Link Status byte Ch. 8	USINT	RO	-

**F101 DeviceState Status data**

Index (hex)	Name	Meaning	Data Type	Flags	Default
F101:0	DeviceState Status data		USINT	RO	0x10 (16 <sub>dec</sub> )
F101:0D	Device Diag	-	BOOL	RO	-
F101:10	Device State	-	BOOL	RO	-

**F102 Digital InputPin2**

Index (hex)	Name	Meaning	Data Type	Flags	Default
F102:0	Digital InputPin2		USINT	RO	0x8 (8 <sub>dec</sub> )
F102:01	Pin2 Ch1	-	BOOL	RO	-
F102:02	Pin2 Ch2	-	BOOL	RO	-
F102:03	Pin2 Ch3	-	BOOL	RO	-
F102:04	Pin2 Ch4	-	BOOL	RO	-
F102:05	Pin2 Ch5	-	BOOL	RO	-
F102:06	Pin2 Ch6	-	BOOL	RO	-
F102:07	Pin2 Ch7	-	BOOL	RO	-
F102:08	Pin2 Ch8	-	BOOL	RO	-

**F900 Info data**

Index (hex)	Name	Meaning	Data Type	Flags	Default
F900:0	Info data		USINT	RO	0x1 (1 <sub>dec</sub> )
F900:01	IO-Link Version	-	USINT	RO	-

### 9.3.3 Standard objects

#### 1000 Device type

Index (hex)	Name	Meaning	Data Type	Flags	Default
1000:0	Device type	Device type of the EtherCAT slave: the Lo-Word contains the used CoE profile (5001). The Hi-Word contains the module profile according to the modular device profile.	UDINT	RO	0x89134C18 (2299743256 <sub>dec</sub> )

#### 1008 Device name

Index (hex)	Name	Meaning	Data Type	Flags	Default
1008:0	Device name	Device name of the EtherCAT slave	STRING(12)	RO	EPP6228-002 2

#### 1009 Hardware version

Index (hex)	Name	Meaning	Data Type	Flags	Default
1009:0	Hardware version	Hardware version of the EtherCAT slave	STRING(2)	RO	-

#### 100A Software version

Index (hex)	Name	Meaning	Data Type	Flags	Default
100A:0	Software version	Firmware version of the EtherCAT slave	STRING(2)	RO	-

#### 1010 Store parameters

Index (hex)	Name	Meaning	Data Type	Flags	Default
1010:0	Store parameters		USINT	RO	0x1 (1 <sub>dec</sub> )

#### 1011 Restore default parameters

Index (hex)	Name	Meaning	Data Type	Flags	Default
1011:0	Restore default parameters	Restoring the default parameters	USINT	RO	0x1 (1 <sub>dec</sub> )
1011:01	SubIndex 001	If this object is set to "0x64616F6C" in the set value dialog, all backup objects are reset to their delivery state.	UINT32	RW	0x00000000 (0 <sub>dec</sub> )

#### 1018 Identity

Index (hex)	Name	Meaning	Data Type	Flags	Default
1018:0	Identity	Information for identifying the slave	USINT	RO	0x4 (4 <sub>dec</sub> )
1018:01	Vendor ID	Vendor ID of the EtherCAT slave	UDINT	RO	0x2 (2 <sub>dec</sub> )
1018:02	Product code	Product code of the EtherCAT slave	UDINT	RO	0x64774B49 (1685539657 <sub>dec</sub> )
1018:03	Revision	Revision number of the EtherCAT slave; the low word (bit 0-15) indicates the special terminal number, the high word (bit 16-31) refers to the device description	UDINT	RO	-
1018:04	Serial number	Serial number of the EtherCAT slave; the low byte (bit 0-7) of the low word contains the year of production, the high byte (bit 8-15) of the low word contains the week of production, the high word (bit 16-31) is 0	UDINT	RO	-

**10F0 Backup parameter handling**

Index (hex)	Name	Meaning	Data Type	Flags	Default
10F0:0	Backup parameter handling	Information for standardized loading and saving of backup entries	USINT	RO	0x1 (1 <sub>dec</sub> )
10F0:01	Checksum	Checksum across all backup entries of the EtherCAT slave	UDINT	RO	-

**10F2 Backup parameter storage**

Index (hex)	Name	Meaning	Data Type	Flags	Default
10F2:0	Backup parameter storage	-	ARRAY [0..3] OF BYTE	RO	-

**10F3 Diagnosis History**

Index (hex)	Name	Meaning	Data Type	Flags	Default
10F3:0	Diagnosis History	Maximum subindex	USINT	RO	0x15 (21 <sub>dec</sub> )
10F3:01	Maximum Messages	Maximum number of stored messages A maximum of 16 messages can be saved	USINT	RO	-
10F3:02	Newest Message	Subindex of the latest message	USINT	RO	-
10F3:03	Newest Acknowledged Message	Subindex of the last acknowledged message	USINT	RW	-
10F3:04	New Messages Available	Indicates that a new message is available	BOOL	RO	-
10F3:05	Flags		UINT	RW	-
10F3:06	Diagnosis Message 001	Message 1	ARRAY [0..27] OF BYTE	RO	-
...	...	...	...	...	...
10F3:15	Diagnosis Message 016	Message 16	ARRAY [0..27] OF BYTE	RO	-

**10F8 Actual Time Stamp**

Index (hex)	Name	Meaning	Data Type	Flags	Default
10F8:0	Actual Time Stamp	-	ULINT	RO	-

**160n IO RxPDO-Map Outputs Ch.x**

- 1600: IO RxPDO-Map Outputs Ch.1
- 1601: IO RxPDO-Map Outputs Ch.2
- 1602: IO RxPDO-Map Outputs Ch.3
- ...
- 1607: IO RxPDO-Map Outputs Ch.8

Index (hex)	Name	Meaning	Data Type	Flags	Default
1600:0	IO RxPDO-Map Outputs Ch.x	-	USINT	RO	-
1600:01	SubIndex 001		UDINT	RW	0x0000:00, 0
1600:02	SubIndex 002		UDINT	RW	0x0000:00, 0
1600:03	SubIndex 003		UDINT	RW	0x0000:00, 0
...	...	...	...	...	...
1600:3E	SubIndex 062		UDINT	RW	0x0000:00, 0
1600:3F	SubIndex 063		UDINT	RW	0x0000:00, 0
1600:40	SubIndex 064		UDINT	RW	0x0000:00, 0

**1A0n IO TxPDO-Map Inputs Ch.x**

- 1A00: IO TxPDO-Map Inputs Ch.1

- 1A01: IO TxPDO-Map Inputs Ch.1
- 1A02: IO TxPDO-Map Inputs Ch.1
- ...
- 1A07: IO TxPDO-Map Inputs Ch.8

Index (hex)	Name	Meaning	Data Type	Flags	Default
1A00:0	IO TxPDO-Map Inputs Ch.x	-	USINT	RO	-
1A00:01	SubIndex 001		UDINT	RW	0x0000:00, 0
1A00:02	SubIndex 002		UDINT	RW	0x0000:00, 0
1A00:03	SubIndex 003		UDINT	RW	0x0000:00, 0
...	...	...	...	...	...
1A00:3E	SubIndex 062		UDINT	RW	0x0000:00, 0
1A00:3F	SubIndex 063		UDINT	RW	0x0000:00, 0
1A00:40	SubIndex 064		UDINT	RW	0x0000:00, 0

**1A20 Digital TxPDO-Map Inputs**

Index (hex)	Name	Meaning	Data Type	Flags	Default
1A20:0	Digital TxPDO-Map Inputs		USINT	RO	0x9 (9 <sub>dec</sub> )
1A20:01	SubIndex 001	PDO Mapping Entry for "Pin2 Ch1".	UDINT	RO	0xf102:01, 1
1A20:02	SubIndex 002	PDO Mapping Entry for "Pin2 Ch2".	UDINT	RO	0xf102:02, 1
1A20:03	SubIndex 003	PDO Mapping Entry for "Pin2 Ch3".	UDINT	RO	0xf102:03, 1
1A20:04	SubIndex 004	PDO Mapping Entry for "Pin2 Ch4".	UDINT	RO	0xf102:04, 1
1A20:05	SubIndex 005	PDO Mapping Entry for "Pin2 Ch5".	UDINT	RO	0xf102:05, 1
1A20:06	SubIndex 006	PDO Mapping Entry for "Pin2 Ch6".	UDINT	RO	0xf102:06, 1
1A20:07	SubIndex 007	PDO Mapping Entry for "Pin2 Ch7".	UDINT	RO	0xf102:07, 1
1A20:08	SubIndex 008	PDO Mapping Entry for "Pin2 Ch8".	UDINT	RO	0xf102:08, 1
1A20:09	SubIndex 009		UDINT	RO	0x0000:00, 8

**1A80 DeviceState TxPDO-Map Inputs**

Index (hex)	Name	Meaning	Data Type	Flags	Default
1A80:0	DeviceState TxPDO-Map Inputs		USINT	RO	0x8 (8 <sub>dec</sub> )
1A80:01	SubIndex 001	PDO Mapping Entry for "State Ch1".	UDINT	RO	0xf100:01, 8
1A80:02	SubIndex 002	PDO Mapping Entry for "State Ch2".	UDINT	RO	0xf100:02, 8
1A80:03	SubIndex 003	PDO Mapping Entry for "State Ch3".	UDINT	RO	0xf100:03, 8
1A80:04	SubIndex 004	PDO Mapping Entry for "State Ch4".	UDINT	RO	0xf100:04, 8
1A80:05	SubIndex 005	PDO Mapping Entry for "State Ch5".	UDINT	RO	0xf100:05, 8
1A80:06	SubIndex 006	PDO Mapping Entry for "State Ch6".	UDINT	RO	0xf100:06, 8
1A80:07	SubIndex 007	PDO Mapping Entry for "State Ch7".	UDINT	RO	0xf100:07, 8
1A80:08	SubIndex 008	PDO Mapping Entry for "State Ch8".	UDINT	RO	0xf100:08, 8

**1A81 DeviceState TxPDO-Map Inputs**

Index (hex)	Name	Meaning	Data Type	Flags	Default
1A81:0	DeviceState TxPDO-Map Inputs		USINT	RO	0x4 (4 <sub>dec</sub> )
1A81:01	SubIndex 001		UDINT	RO	0x0000:00, 12
1A81:02	SubIndex 002	PDO Mapping Entry for "Device Diag".	UDINT	RO	0xf101:0d, 1
1A81:03	SubIndex 003		UDINT	RO	0x0000:00, 2
1A81:04	SubIndex 004	PDO Mapping Entry for "Device State".	UDINT	RO	0xf101:10, 1

**1C00 Sync manager type**

Index (hex)	Name	Meaning	Data Type	Flags	Default
1C00:0	Sync manager type		USINT	RO	0x4 (4 <sub>dec</sub> )
1C00:01	SubIndex 001	Sync Manager Type Channel 1: Mailbox Write	USINT	RO	0x1 (1 <sub>dec</sub> )
1C00:02	SubIndex 002	Sync Manager Type Channel 2: Mailbox Read	USINT	RO	0x2 (2 <sub>dec</sub> )
1C00:03	SubIndex 003	Sync Manager Type Channel 3: Process Data Write (Outputs)	USINT	RO	0x3 (3 <sub>dec</sub> )
1C00:04	SubIndex 004	Sync Manager Type Channel 4: Process Data Read (Inputs)	USINT	RO	0x4 (4 <sub>dec</sub> )

**1C12 RxPDO assign**

Index (hex)	Name	Meaning	Data Type	Flags	Default
1C12:0	RxPDO assign		USINT	RO	0x8 (8 <sub>dec</sub> )
1C12:01	SubIndex 001		UINT	RW	0x16 (22 <sub>dec</sub> )
1C12:02	SubIndex 002		UINT	RW	0x116 (278 <sub>dec</sub> )
1C12:03	SubIndex 003		UINT	RW	0x216 (534 <sub>dec</sub> )
1C12:04	SubIndex 004		UINT	RW	0x316 (790 <sub>dec</sub> )
1C12:05	SubIndex 005		UINT	RW	0x416 (1046 <sub>dec</sub> )
1C12:06	SubIndex 006		UINT	RW	0x516 (1302 <sub>dec</sub> )
1C12:07	SubIndex 007		UINT	RW	0x616 (1558 <sub>dec</sub> )
1C12:08	SubIndex 008		UINT	RW	0x716 (1814 <sub>dec</sub> )

**1C13 TxPDO assign**

Index (hex)	Name	Meaning	Data Type	Flags	Default
1C13:0	TxPDO assign		USINT	RO	0xB (11 <sub>dec</sub> )
1C13:01	SubIndex 001		UINT	RW	0x1A (26 <sub>dec</sub> )
1C13:02	SubIndex 002		UINT	RW	0x11A (282 <sub>dec</sub> )
1C13:03	SubIndex 003		UINT	RW	0x21A (538 <sub>dec</sub> )
1C13:04	SubIndex 004		UINT	RW	0x31A (794 <sub>dec</sub> )
1C13:05	SubIndex 005		UINT	RW	0x41A (1050 <sub>dec</sub> )
1C13:06	SubIndex 006		UINT	RW	0x51A (1306 <sub>dec</sub> )
1C13:07	SubIndex 007		UINT	RW	0x61A (1562 <sub>dec</sub> )
1C13:08	SubIndex 008		UINT	RW	0x71A (1818 <sub>dec</sub> )
1C13:09	SubIndex 009		UINT	RW	0x201A (8218 <sub>dec</sub> )
1C13:0A	SubIndex 010		UINT	RW	0x801A (32794 <sub>dec</sub> )
1C13:0B	SubIndex 011		UINT	RW	0x811A (33050 <sub>dec</sub> )

**1C32 SM output parameter**

Index (hex)	Name	Meaning	Data Type	Flags	Default
1C32:0	SM output parameter	Synchronization parameters for the outputs	USINT	RO	0x20 (32 <sub>dec</sub> )
1C32:01	Sync mode	Current synchronization mode: 0: Free Run 1: Synchronous with SM 2 Event 2: DC-Mode - synchronous with SYNC0 Event 3: DC-Mode - synchronous with SYNC1 Event	UINT	RW	0x1 (1 <sub>dec</sub> )
1C32:02	Cycle time	Cycle time (in ns): Free Run: cycle time of the local timer Synchronous with SM 2 Event: cycle time of the master DC-Mode: SYNC0/SYNC1 Cycle Time	UDINT	RW	0x7A120 (500000 <sub>dec</sub> )
1C32:03	Shift time	Time between SYNC0 event and output of the outputs (in ns, DC mode only)	UDINT	RO	0x0 (0 <sub>dec</sub> )
1C32:04	Sync modes supported	Sync modes supported: Bit 0 = 1: Free Run is supported Bit 1 = 1: Synchronization with SM 2 Event is supported Bit 2-3 = 01: DC-Mode is supported Bit 4-5 = 10: Output Shift with SYNC1 Event (DC mode only) Bit 14 = 1: dynamic times (measurement through writing of 1C32:08)	UINT	RO	0x3 (3 <sub>dec</sub> )
1C32:05	Minimum cycle time	Minimum cycle time (in ns)	UDINT	RO	0x7A120 (500000 <sub>dec</sub> )
1C32:06	Calc and copy time	Minimum time between SYNC0 and SYNC1 event (in ns, DC Mode only)	UDINT	RO	0x0 (0 <sub>dec</sub> )
1C32:07	Minimum delay time		UDINT	RO	0x0 (0 <sub>dec</sub> )
1C32:08	Command	0: Measurement of the local cycle time is stopped 1: Measurement of the local cycle time is started The entries 1C32:03, 1C32:05, 1C32:06, 1C32:09, 1C33:03, 1C33:06, 1C33:09 are updated with the maximum measured values. For a subsequent measurement the measured values are reset	UINT	RW	0x0 (0 <sub>dec</sub> )
1C32:09	Maximum delay time	Time between SYNC1 event and output of the outputs (in ns, DC mode only)	UDINT	RO	0x0 (0 <sub>dec</sub> )
1C32:0B	SM event missed counter	Number of missed SM events in OPERATIONAL (DC Mode only)	UINT	RO	-
1C32:0C	Cycle exceeded counter	Number of occasions the cycle time was exceeded in OPERATIONAL (cycle was not completed in time or the next cycle began too early)	UINT	RO	-
1C32:0D	Shift too short counter	Number of intervals between SYNC0 and SYNC1 events that are too short (DC Mode only)	UINT	RO	-
1C32:20	Sync error	The synchronization was not correct in the last cycle (outputs were output too late; DC Mode only)	BOOL	RO	-

**1C33 SM input parameter**

Index (hex)	Name	Meaning	Data Type	Flags	Default
1C33:0	SM input parameter	Synchronization parameters for the inputs	USINT	RO	0x20 (32 <sub>dec</sub> )
1C33:01	Sync mode	Current synchronization mode: 0: Free Run 1: Synchronous with SM 3 Event (no outputs available) 2: DC - Synchronous with SYNC0 Event 3: DC - Synchronous with SYNC1 Event 34: Synchronous with SM 2 Event (outputs available)	UINT	RW	0x22 (34 <sub>dec</sub> )
1C33:02	Cycle time	as 1C32:02	UDINT	RW	0x7A120 (500000 <sub>dec</sub> )
1C33:03	Shift time	Time between SYNC0 event and reading of the inputs (in ns, DC Mode only)	UDINT	RO	0x0 (0 <sub>dec</sub> )
1C33:04	Sync modes supported	Sync modes supported: Bit 0: Free Run is supported Bit 1: Synchronization with SM 2 Event is supported (outputs available) Bit 1: Synchronization with SM 3 Event is supported (no outputs available) Bit 2-3 = 01: DC-Mode is supported Bit 4-5 = 01: Input shift through local event (outputs available) Bit 4-5 = 10: Input shift with SYNC1 event (no outputs available) Bit 14 = 1: dynamic times (measurement through writing of 1C32:08 or 1C33:08)	UINT	RO	0x3 (3 <sub>dec</sub> )
1C33:05	Minimum cycle time	as 1C32:05	UDINT	RO	0x7A120 (500000 <sub>dec</sub> )
1C33:06	Calc and copy time	Time between reading of the inputs and the inputs being available for the master (in ns, DC Mode only)	UDINT	RO	0x0 (0 <sub>dec</sub> )
1C33:07	Minimum delay time		UDINT	RO	0x0 (0 <sub>dec</sub> )
1C33:08	Command	as 1C32:08	UINT	RW	0x0 (0 <sub>dec</sub> )
1C33:09	Maximum delay time	Time between SYNC1 event and reading of the inputs (in ns, DC Mode only)	UDINT	RO	0x0 (0 <sub>dec</sub> )
1C33:0B	SM event missed counter	as 1C32:11	UINT	RO	-
1C33:0C	Cycle exceeded counter	as 1C32:12	UINT	RO	-
1C33:0D	Shift too short counter	as 1C32:13	UINT	RO	-
1C33:20	Sync error	as 1C32:32	BOOL	RO	-

**F000 Modular device profile**

Index (hex)	Name	Meaning	Data Type	Flags	Default
F000:0	Modular device profile		USINT	RO	0x2 (2 <sub>dec</sub> )
F000:01	Module index distance		UINT	RO	0x10 (16 <sub>dec</sub> )
F000:02	Maximum number of modules		UINT	RO	0x8 (8 <sub>dec</sub> )

**F008 Code word**

Index (hex)	Name	Meaning	Data Type	Flags	Default
F008:0	Code word	-	UDINT	RO	-

**F010 Module list**

Index (hex)	Name	Meaning	Data Type	Flags	Default
F010:0	Module list		USINT	RO	0x8 (8 <sub>dec</sub> )
F010:01	SubIndex 001		UDINT	RW	0x4C180000 (1276641280 <sub>d</sub> ec)
F010:02	SubIndex 002		UDINT	RW	0x4C180000 (1276641280 <sub>d</sub> ec)
F010:03	SubIndex 003		UDINT	RW	0x4C180000 (1276641280 <sub>d</sub> ec)
F010:04	SubIndex 004		UDINT	RW	0x4C180000 (1276641280 <sub>d</sub> ec)
F010:05	SubIndex 005		UDINT	RW	0x4C180000 (1276641280 <sub>d</sub> ec)
F010:06	SubIndex 006		UDINT	RW	0x4C180000 (1276641280 <sub>d</sub> ec)
F010:07	SubIndex 007		UDINT	RW	0x4C180000 (1276641280 <sub>d</sub> ec)
F010:08	SubIndex 008		UDINT	RW	0x4C180000 (1276641280 <sub>d</sub> ec)

# 10 Appendix

## 10.1 General operating conditions

### Protection rating according to IP code

The degrees of protection are defined and divided into different classes in the IEC 60529 standard (EN 60529). Degrees of protection are designated by the letters "IP" and two numerals: **IPxy**

- Numeral x: Dust protection and contact protection
- Numeral y: Protection against water

x	Meaning
0	Not protected
1	Protected against access to dangerous parts with the back of the hand. Protected against solid foreign objects of 50 mm Ø
2	Protected against access to dangerous parts with a finger. Protected against solid foreign objects of 12.5 mm Ø
3	Protected against access to dangerous parts with a tool. Protected against solid foreign objects of 2.5 mm Ø
4	Protected against access to dangerous parts with a wire. Protected against solid foreign objects of 1 mm Ø
5	Protection against access to dangerous parts with a wire. Dust-protected. Ingress of dust is not prevented completely, although the quantity of dust able to penetrate is limited to such an extent that the proper function of the device and safety are not impaired
6	Protection against access to dangerous parts with a wire. Dust-tight. No ingress of dust

y	Meaning
0	Not protected
1	Protection against vertically falling water drops
2	Protection against vertically falling water drops when enclosure tilted up to 15°
3	Protection against spraying water. Water sprayed at an angle of up to 60° on either side of the vertical shall have no harmful effects
4	Protection against splashing water. Water splashed against the enclosure from any direction shall have no harmful effects
5	Protection against water jets.
6	Protection against powerful water jets.
7	Protected against the effects of temporary immersion in water. Ingress of water in quantities causing harmful effects shall not be possible when the enclosure is immersed in water at a depth of 1 m for 30 minutes

### Chemical resistance

The resistance refers to the housing of the IP67 modules and the metal parts used. In the table below you will find some typical resistances.

Type	Resistance
Water vapor	unstable at temperatures > 100 °C
Sodium hydroxide solution (ph value > 12)	stable at room temperature unstable > 40 °C
Acetic acid	unstable
Argon (technically pure)	stable

### Key

- resistant: Lifetime several months
- non inherently resistant: Lifetime several weeks
- not resistant: Lifetime several hours resp. early decomposition

## 10.2 Accessories

### Mounting

Ordering information	Description	Link
ZS5300-0011	Mounting rail	<a href="#">Website</a>

### Cables

A complete overview of pre-assembled cables can be found on the Beckhoff website: [Link](#).

Ordering information	Description	Link
ZK2000-6xxx-xxxx	Sensor cable M12, 4-pin	<a href="#">Website</a>
ZK2000-7xxx-0xxx	Sensor cable M12, 4-pin + shield	<a href="#">Website</a>
ZK700x-xxxx-xxxx	EtherCAT P cable M8	<a href="#">Website</a>

### Labeling material, protective caps

Ordering information	Description
ZS5000-0012	Protective cap for M8 sockets, P-coded, IP67 (50 pieces)
ZS5000-0020	Protective cap for M12 sockets, IP67 (50 pcs.)
ZS5100-0000	Inscription labels, unprinted, 4 strips of 10
ZS5000-xxxx	Printed inscription labels on enquiry

### Tools

Ordering information	Description
ZB8801-0000	Torque wrench for plugs, 0.4...1.0 Nm
ZB8801-0001	Torque cable key for M8 / wrench size 9 for ZB8801-0000
ZB8801-0002	Torque cable key for M12 / wrench size 13 for ZB8801-0000
ZB8801-0003	Torque cable key for M12 field assembly / wrench size 18 for ZB8801-0000

#### Further accessories

Further accessories can be found in the price list for fieldbus components from Beckhoff and online at <https://www.beckhoff.com>.

## 10.3 Version identification of EtherCAT devices

### 10.3.1 General notes on marking

#### Designation

A Beckhoff EtherCAT device has a 14-digit designation, made up of

- family key
- type
- version
- revision

Example	Family	Type	Version	Revision
EL3314-0000-0016	EL terminal 12 mm, non-pluggable connection level	3314 4-channel thermocouple terminal	0000 basic type	0016
ES3602-0010-0017	ES terminal 12 mm, pluggable connection level	3602 2-channel voltage measurement	0010 high-precision version	0017
CU2008-0000-0000	CU device	2008 8-port fast ethernet switch	0000 basic type	0000

#### Notes

- The elements mentioned above result in the **technical designation**. EL3314-0000-0016 is used in the example below.
- EL3314-0000 is the order identifier, in the case of "-0000" usually abbreviated to EL3314. "-0016" is the EtherCAT revision.
- The **order identifier** is made up of
  - family key (EL, EP, CU, ES, KL, CX, etc.)
  - type (3314)
  - version (-0000)
- The **revision** -0016 shows the technical progress, such as the extension of features with regard to the EtherCAT communication, and is managed by Beckhoff.  
In principle, a device with a higher revision can replace a device with a lower revision, unless specified otherwise, e.g. in the documentation.  
Associated and synonymous with each revision there is usually a description (ESI, EtherCAT Slave Information) in the form of an XML file, which is available for download from the Beckhoff web site.  
From 2014/01 the revision is shown on the outside of the IP20 terminals, see Fig. "EL2872 with revision 0022 and serial number 01200815".
- The type, version and revision are read as decimal numbers, even if they are technically saved in hexadecimal.

### 10.3.2 Version identification of IP67 modules

The serial number/ data code for Beckhoff IO devices is usually the 8-digit number printed on the device or on a sticker. The serial number indicates the configuration in delivery state and therefore refers to a whole production batch, without distinguishing the individual modules of a batch.

Structure of the serial number: **KK YY FF HH**

KK - week of production (CW, calendar week)  
 YY - year of production  
 FF - firmware version  
 HH - hardware version

Example with serial number 12 06 3A 02:

12 - production week 12  
 06 - production year 2006  
 3A - firmware version 3A  
 02 - hardware version 02

Exceptions can occur in the **IP67 area**, where the following syntax can be used (see respective device documentation):

Syntax: D ww yy x y z u

D - prefix designation  
 ww - calendar week  
 yy - year  
 x - firmware version of the bus PCB  
 y - hardware version of the bus PCB  
 z - firmware version of the I/O PCB  
 u - hardware version of the I/O PCB

Example: D.22081501 calendar week 22 of the year 2008 firmware version of bus PCB: 1 hardware version of bus PCB: 5 firmware version of I/O PCB: 0 (no firmware necessary for this PCB) hardware version of I/O PCB: 1

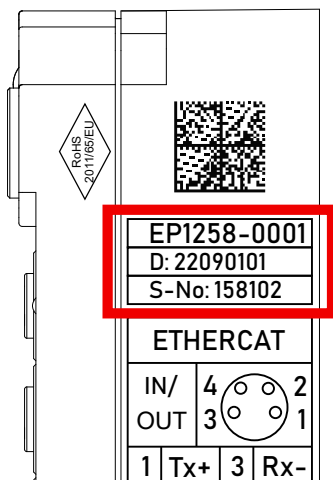

Fig. 40: EP1258-00001 IP67 EtherCAT Box with batch number/DateCode 22090101 and unique serial number 158102

### 10.3.3 Beckhoff Identification Code (BIC)

The Beckhoff Identification Code (BIC) is increasingly being applied to Beckhoff products to uniquely identify the product. The BIC is represented as a Data Matrix Code (DMC, code scheme ECC200), the content is based on the ANSI standard MH10.8.2-2016.

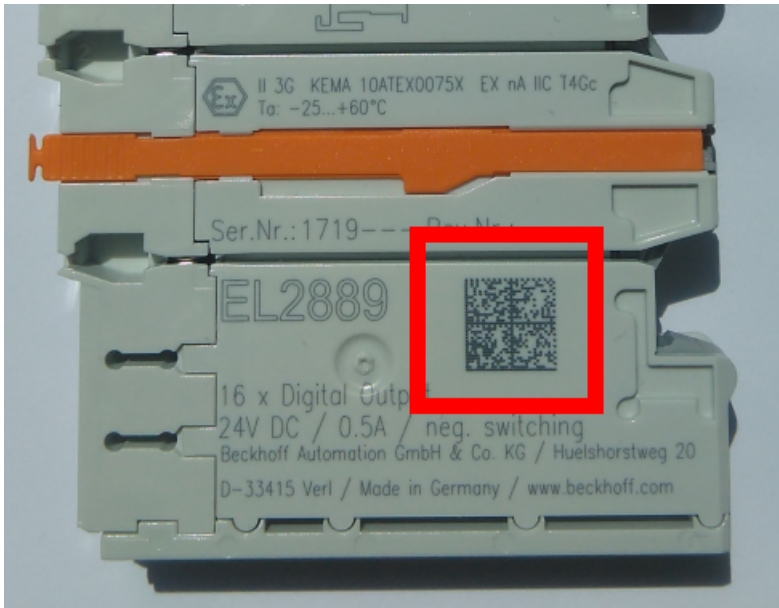

Fig. 41: BIC as data matrix code (DMC, code scheme ECC200)

The BIC will be introduced step by step across all product groups.

Depending on the product, it can be found in the following places:

- on the packaging unit
- directly on the product (if space suffices)
- on the packaging unit and the product

The BIC is machine-readable and contains information that can also be used by the customer for handling and product management.

Each piece of information can be uniquely identified using the so-called data identifier (ANSI MH10.8.2-2016). The data identifier is followed by a character string. Both together have a maximum length according to the table below. If the information is shorter, spaces are added to it.

Following information is possible, positions 1 to 4 are always present, the other according to need of production:

Position	Type of information	Explanation	Data identifier	Number of digits incl. data identifier	Example
1	Beckhoff order number	<b>Beckhoff order number</b>	1P	8	<b>1P</b> 072222
2	Beckhoff Traceability Number (BTN)	<b>Unique serial number, see note below</b>	SBTN	12	<b>SBTN</b> k4p562d7
3	Article description	<b>Beckhoff article description, e.g. EL1008</b>	1K	32	<b>1KEL</b> 1809
4	Quantity	<b>Quantity in packaging unit, e.g. 1, 10, etc.</b>	Q	6	<b>Q1</b>
5	Batch number	Optional: Year and week of production	2P	14	<b>2P</b> 401503180016
6	ID/serial number	Optional: Present-day serial number system, e.g. with safety products	51S	12	<b>51S</b> 678294
7	Variant number	Optional: Product variant number on the basis of standard products	30P	12	<b>30P</b> F971, 2*K183
...					

Further types of information and data identifiers are used by Beckhoff and serve internal processes.

**Structure of the BIC**

Example of composite information from positions 1 to 4 and with the above given example value on position 6. The data identifiers are highlighted in bold font:

**1P**072222**SBTN**k4p562d7**1KEL**1809 **Q1** **51S**678294

Accordingly as DMC:



Fig. 42: Example DMC **1P072222SBTN**k4p562d7**1KEL**1809 **Q1** **51S**678294

**BTN**

An important component of the BIC is the Beckhoff Traceability Number (BTN, position 2). The BTN is a unique serial number consisting of eight characters that will replace all other serial number systems at Beckhoff in the long term (e.g. batch designations on IO components, previous serial number range for safety products, etc.). The BTN will also be introduced step by step, so it may happen that the BTN is not yet coded in the BIC.

**NOTICE**

This information has been carefully prepared. However, the procedure described is constantly being further developed. We reserve the right to revise and change procedures and documentation at any time and without prior notice. No claims for changes can be made from the information, illustrations and descriptions in this documentation.

## 10.3.4 Electronic access to the BIC (eBIC)

### Electronic BIC (eBIC)

The Beckhoff Identification Code (BIC) is applied to the outside of Beckhoff products in a visible place. If possible, it should also be electronically readable.

The interface that the product can be electronically addressed by is crucial for the electronic readout.

### EtherCAT devices (IP20, IP67)

All Beckhoff EtherCAT devices have an ESI-EEPROM which contains the EtherCAT identity with the revision number. The EtherCAT slave information, also colloquially known as the ESI/XML configuration file for the EtherCAT master, is stored in it. See the corresponding chapter in the EtherCAT system manual ([Link](#)) for the relationships.

Beckhoff also stores the eBIC in the ESI-EEPROM. The eBIC was introduced into Beckhoff IO production (terminals, box modules) in 2020; as of 2023, implementation is largely complete.

The user can electronically access the eBIC (if present) as follows:

- With all EtherCAT devices, the EtherCAT master (TwinCAT) can read the eBIC from the ESI-EEPROM
  - From TwinCAT 3.1 build 4024.11, the eBIC can be displayed in the online view.
  - To do this, check the "Show Beckhoff Identification Code (BIC)" checkbox under EtherCAT → Advanced Settings → Diagnostics:

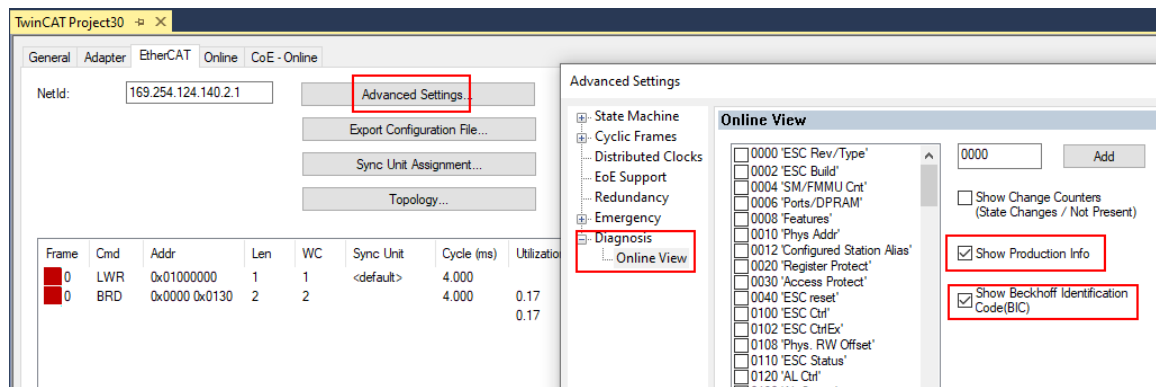

- The BTN and its contents are then displayed:

No	Addr	Name	State	CRC	Fw	Hw	Production Data	ItemNo	BTN	Description	Quantity	BatchNo	SerialNo
1	1001	Term 1 (EK1100)	OP	0,0	0	0	---						
2	1002	Term 2 (EL1018)	OP	0,0	0	0	2020 KW36 Fr	072222	k4p562d7	EL1809	1		678294
3	1003	Term 3 (EL3204)	OP	0,0	7	6	2012 KW24 Sa						
4	1004	Term 4 (EL2004)	OP	0,0	0	0	---	072223	k4p562d7	EL2004	1		678295
5	1005	Term 5 (EL1008)	OP	0,0	0	0	---						
6	1006	Term 6 (EL2008)	OP	0,0	0	12	2014 KW14 Mo						
7	1007	Term 7 (EK1110)	OP	0	1	8	2012 KW25 Mo						

- Note: As shown in the figure, the production data HW version, FW version, and production date, which have been programmed since 2012, can also be displayed with "Show production info".
- Access from the PLC: From TwinCAT 3.1. build 4024.24, the functions *FB\_EcReadBIC* and *FB\_EcReadBTN* for reading into the PLC are available in the Tc2\_EtherCAT library from v3.3.19.0.
- EtherCAT devices with a CoE directory may also have the object 0x10E2:01 to display their own eBIC, which can also be easily accessed by the PLC:

- The device must be in PREOP/SAFEOP/OP for access:

Index	Name	Flags	Value
1000	Device type	RO	0x015E1389 (22942601)
1008	Device name	RO	ELM3704-0000
1009	Hardware version	RO	00
100A	Software version	RO	01
100B	Bootloader version	RO	J0.1.27.0
1011:0	Restore default parameters	RO	> 1 <
1018:0	Identity	RO	> 4 <
10E2:0	Manufacturer-specific Identification C...	RO	> 1 <
10E2:01	SubIndex 001	RO	1P158442SBTN0008jckp1KELM3704 Q1 2P482001000016
10F0:0	Backup parameter handling	RO	> 1 <
10F3:0	Diagnosis History	RO	> 21 <
10F8	Actual Time Stamp	RO	0x170bfb277e

- The object 0x10E2 will be preferentially introduced into stock products in the course of necessary firmware revision.
- From TwinCAT 3.1. build 4024.24, the functions *FB\_EcCoEReadBIC* and *FB\_EcCoEReadBTN* for reading into the PLC are available in the *Tc2\_EtherCAT* library from v3.3.19.0
- The following auxiliary functions are available for processing the BIC/BTN data in the PLC in *Tc2\_Uilities* as of TwinCAT 3.1 build 4024.24
  - *F\_SplitBIC*: The function splits the Beckhoff Identification Code (BIC) *sBICValue* into its components using known identifiers and returns the recognized substrings in the *ST\_SplittedBIC* structure as a return value
  - *BIC\_TO\_BTN*: The function extracts the BTN from the BIC and returns it as a return value
- Note: If there is further electronic processing, the BTN is to be handled as a string(8); the identifier "SBTN" is not part of the BTN.
- Technical background  
 The new BIC information is written as an additional category in the ESI-EEPROM during device production. The structure of the ESI content is largely dictated by the ETG specifications, therefore the additional vendor-specific content is stored using a category in accordance with the ETG.2010. ID 03 tells all EtherCAT masters that they may not overwrite these data in the event of an update or restore the data after an ESI update.  
 The structure follows the content of the BIC, see here. The EEPROM therefore requires approx. 50..200 bytes of memory.
- Special cases
  - If multiple hierarchically arranged ESCs are installed in a device, only the top-level ESC carries the eBIC information.
  - If multiple non-hierarchically arranged ESCs are installed in a device, all ESCs carry the eBIC information.
  - If the device consists of several sub-devices which each have their own identity, but only the top-level device is accessible via EtherCAT, the eBIC of the top-level device is located in the CoE object directory 0x10E2:01 and the eBICs of the sub-devices follow in 0x10E2:nn.

## 10.4 Support and Service

Beckhoff and their partners around the world offer comprehensive support and service, making available fast and competent assistance with all questions related to Beckhoff products and system solutions.

### Beckhoff's branch offices and representatives

Please contact your Beckhoff branch office or representative for local support and service on Beckhoff products!

The addresses of Beckhoff's branch offices and representatives round the world can be found on her internet pages: [www.beckhoff.com](http://www.beckhoff.com)

You will also find further documentation for Beckhoff components there.

### Support

The Beckhoff Support offers you comprehensive technical assistance, helping you not only with the application of individual Beckhoff products, but also with other, wide-ranging services:

- support
- design, programming and commissioning of complex automation systems
- and extensive training program for Beckhoff system components

Hotline: +49 5246 963 157  
e-mail: [support@beckhoff.com](mailto:support@beckhoff.com)  
web: [www.beckhoff.com/support](http://www.beckhoff.com/support)

### Service

The Beckhoff Service Center supports you in all matters of after-sales service:

- on-site service
- repair service
- spare parts service
- hotline service

Hotline: +49 5246 963 460  
e-mail: [service@beckhoff.com](mailto:service@beckhoff.com)  
web: [www.beckhoff.com/service](http://www.beckhoff.com/service)

### Headquarters Germany

Beckhoff Automation GmbH & Co. KG

Hülshorstweg 20  
33415 Verl  
Germany

Phone: +49 5246 963 0  
e-mail: [info@beckhoff.com](mailto:info@beckhoff.com)  
web: [www.beckhoff.com](http://www.beckhoff.com)

## **Trademark statements**

Beckhoff®, ATRO®, EtherCAT®, EtherCAT G®, EtherCAT G10®, EtherCAT P®, MX-System®, Safety over EtherCAT®, TC/BSD®, TwinCAT®, TwinCAT/BSD®, TwinSAFE®, XFC®, XPlanar® and XTS® are registered and licensed trademarks of Beckhoff Automation GmbH.

## **Third-party trademark statements**

IO-Link is a registered trademark of PROFIBUS Nutzerorganisation e.V.

More Information:  
[www.beckhoff.com/io-link](http://www.beckhoff.com/io-link)

Beckhoff Automation GmbH & Co. KG  
Hülshorstweg 20  
33415 Verl  
Germany  
Phone: +49 5246 9630  
[info@beckhoff.com](mailto:info@beckhoff.com)  
[www.beckhoff.com](http://www.beckhoff.com)

