

Documentation | EN

EPP4174-0002

4-channel analog output, ± 10 V, 0/4...20 mA, 16 bit, differential



Table of contents

1	Foreword	5
1.1	Notes on the documentation	5
1.2	Safety instructions	6
1.3	Documentation issue status	7
2	Product group: EtherCAT P Box modules	8
3	Product overview	9
3.1	Introduction	9
3.2	Technical data	10
3.3	Scope of supply.....	11
3.4	Status LEDs	12
3.5	Process image	13
4	Mounting and connection	14
4.1	Mounting	14
4.1.1	Dimensions	14
4.1.2	Fixing.....	15
4.1.3	Functional earth (FE)	15
4.1.4	Tightening torques for plug connectors.....	15
4.2	EtherCAT P	16
4.2.1	Connectors.....	17
4.2.2	Status LEDs	18
4.2.3	Conductor losses	19
4.3	Signal connection.....	20
4.4	UL Requirements	21
4.5	Disposal	22
5	Commissioning/Configuration	23
5.1	Integrating into a TwinCAT project.....	23
5.2	Object overview.....	24
5.3	Object description and parameterization.....	27
5.3.1	Objects to be parameterized during commissioning	27
5.3.2	Objects for regular operation.....	32
5.3.3	Standard objects (0x1000-0x1FFF)	32
5.3.4	Profile-specific objects (0x6000-0xFFFF)	35
5.4	Restore the delivery state	38
6	Appendix	39
6.1	General operating conditions	39
6.2	Accessories	40
6.3	Further documentation for I/O components with analog in and outputs.....	41
6.4	Version identification of EtherCAT devices	42
6.4.1	General notes on marking.....	42
6.4.2	Version identification of IP67 modules	43
6.4.3	Beckhoff Identification Code (BIC).....	44
6.4.4	Electronic access to the BIC (eBIC).....	46
6.5	Support and Service.....	48

1 Foreword

1.1 Notes on the documentation

Intended audience

This description is only intended for the use of trained specialists in control and automation engineering who are familiar with the applicable national standards.

It is essential that the documentation and the following notes and explanations are followed when installing and commissioning these components.

The qualified personnel is obliged to always use the currently valid documentation.

The responsible staff must ensure that the application or use of the products described satisfy all the requirements for safety, including all the relevant laws, regulations, guidelines and standards.

Disclaimer

The documentation has been prepared with care. The products described are, however, constantly under development.

We reserve the right to revise and change the documentation at any time and without prior announcement.

No claims for the modification of products that have already been supplied may be made on the basis of the data, diagrams and descriptions in this documentation.

Trademarks

Beckhoff®, TwinCAT®, TwinCAT/BSD®, TC/BSD®, EtherCAT®, EtherCAT G®, EtherCAT G10®, EtherCAT P®, Safety over EtherCAT®, TwinSAFE®, XFC®, XTS® and XPlanar® are registered trademarks of and licensed by Beckhoff Automation GmbH. Other designations used in this publication may be trademarks whose use by third parties for their own purposes could violate the rights of the owners.

Patent Pending

The EtherCAT Technology is covered, including but not limited to the following patent applications and patents: EP1590927, EP1789857, EP1456722, EP2137893, DE102015105702 with corresponding applications or registrations in various other countries.



EtherCAT® is registered trademark and patented technology, licensed by Beckhoff Automation GmbH, Germany.

Copyright

© Beckhoff Automation GmbH & Co. KG, Germany.

The reproduction, distribution and utilization of this document as well as the communication of its contents to others without express authorization are prohibited.

Offenders will be held liable for the payment of damages. All rights reserved in the event of the grant of a patent, utility model or design.

1.2 Safety instructions

Safety regulations

Please note the following safety instructions and explanations!
Product-specific safety instructions can be found on following pages or in the areas mounting, wiring, commissioning etc.

Exclusion of liability

All the components are supplied in particular hardware and software configurations appropriate for the application. Modifications to hardware or software configurations other than those described in the documentation are not permitted, and nullify the liability of Beckhoff Automation GmbH & Co. KG.

Personnel qualification

This description is only intended for trained specialists in control, automation and drive engineering who are familiar with the applicable national standards.

Signal words

The signal words used in the documentation are classified below. In order to prevent injury and damage to persons and property, read and follow the safety and warning notices.

Personal injury warnings

⚠ DANGER

Hazard with high risk of death or serious injury.

⚠ WARNING

Hazard with medium risk of death or serious injury.

⚠ CAUTION

There is a low-risk hazard that could result in medium or minor injury.

Warning of damage to property or environment

NOTICE

The environment, equipment, or data may be damaged.

Information on handling the product



This information includes, for example:
recommendations for action, assistance or further information on the product.

1.3 Documentation issue status

Version	Comment
1.3	<ul style="list-style-type: none"> • Introduction updated
1.2	<ul style="list-style-type: none"> • EtherCAT P status LEDs updated • Technical data updated • Signal connection updated
1.1	<ul style="list-style-type: none"> • Dimensions updated • UL requirements updated
1.0	<ul style="list-style-type: none"> • First release

Firmware and hardware versions

This documentation refers to the firmware and hardware version that was applicable at the time the documentation was written.

The module features are continuously improved and developed further. Modules having earlier production statuses cannot have the same properties as modules with the latest status. However, existing properties are retained and are not changed, so that older modules can always be replaced with new ones.

The firmware and hardware version (delivery state) can be found in the batch number (D-number) printed on the side of the EtherCAT Box.

Syntax of the batch number (D-number)

D: WW YY FF HH

WW - week of production (calendar week)

YY - year of production

FF - firmware version

HH - hardware version

Example with D no. 29 10 02 01:

29 - week of production 29

10 - year of production 2010

02 - firmware version 02

01 - hardware version 01

Further information on this topic: [Version identification of EtherCAT devices \[► 42\]](#).

2 Product group: EtherCAT P Box modules

EtherCAT P

EtherCAT P supplements the EtherCAT technology with a process in which communication and supply voltages are transmitted on a common line. All EtherCAT properties are retained with this process.

Two supply voltages are transmitted per EtherCAT P line. The supply voltages are electrically isolated from each other and can therefore be switched individually. The nominal supply voltage for both is $24 V_{DC}$.

EtherCAT P uses the same cable structure as EtherCAT: a 4-core Ethernet cable with M8 connectors. The connectors are mechanically coded so that EtherCAT connectors and EtherCAT P connectors cannot be interchanged.

EtherCAT P Box modules

EtherCAT P Box modules are EtherCAT P slaves with degree of protection IP67. They are designed for operation in wet, dirty or dusty industrial environments.

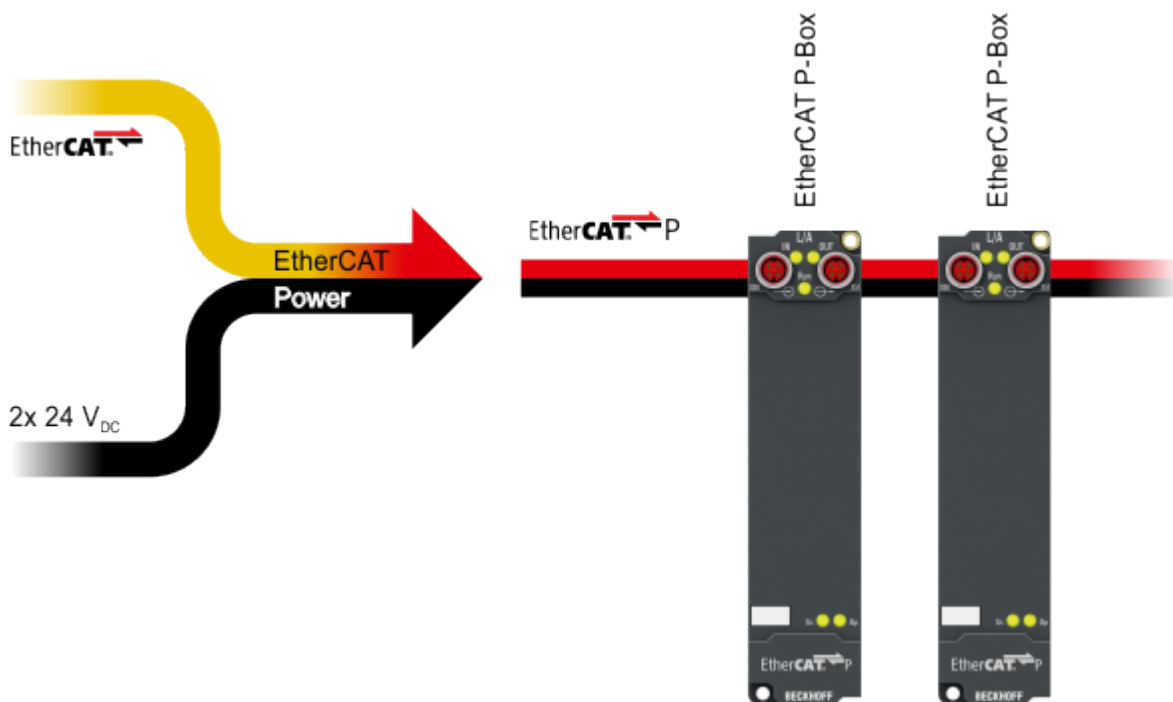

i EtherCAT basics

A detailed description of the EtherCAT system can be found in the [EtherCAT system documentation](#).

3 Product overview

3.1 Introduction

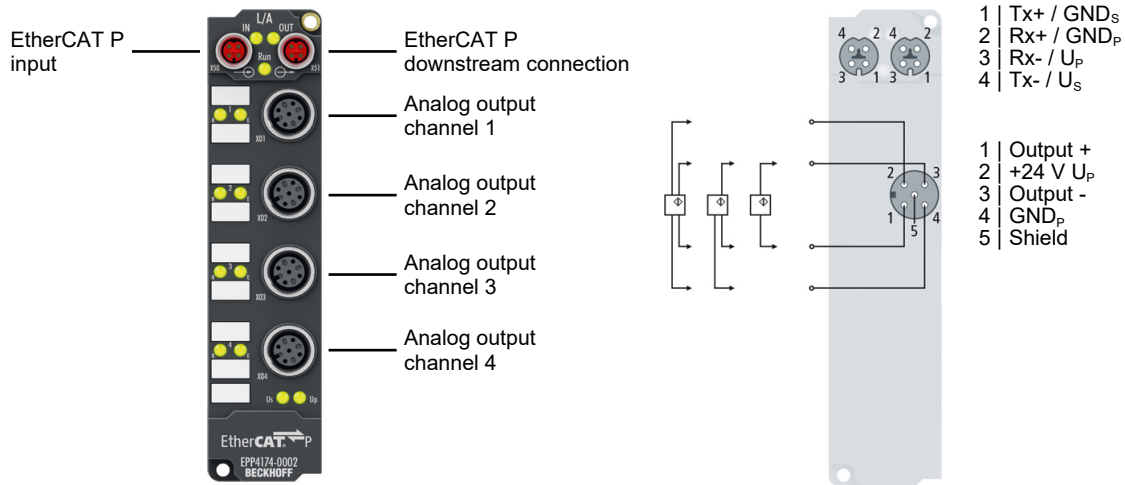

The EPP4174-0002 EtherCAT P Box has four analog outputs which can be individually parameterised, so that they generate signals either in the -10 ... +10 V or the 0/4 ... 20 mA range.

The voltage or output current is supplied to the process level with a resolution of 15 bit (default), and is electrically isolated. The output scaling can be changed if required.

The four outputs have a common ground potential, which is galvanically isolated from the ground potentials of the supply voltages. The analog actuators are supplied from the load voltage (freely selectable up to 30 V_{DC}). The applied load voltage is available for actuator supply of further EtherCAT P Box modules.

Quick links

- [Technical data \[▶ 10\]](#)
- [Process image \[▶ 13\]](#)
- [Dimensions \[▶ 14\]](#)
- [Signal interface \[▶ 20\]](#)

3.2 Technical data

All values are typical values over the entire temperature range, unless stated otherwise.

EtherCAT P	
Connection	2 x M8 socket, 4-pin, P-coded, shielded

Supply voltages	
Connection	See EtherCAT P connection
U_S nominal voltage	24 V _{DC} (-15 % / +20 %)
U_S sum current: $I_{S,sum}$	max. 3 A
Current consumption from U_S	100 mA
Rated voltage U_P	24 V _{DC} (-15 % / +20 %)
U_P sum current: $I_{P,sum}$	max. 3 A
Current consumption from U_P	= Output current from the auxiliary voltage outputs (pin 2 of the M12 sockets)

Analog outputs	
Number	4
Connection	4x M12 socket, 5-pin, A-coded
Cable length	max. 30 m
Signal type	Adjustable: <ul style="list-style-type: none"> • -10...+10 V (default) • 0...+10 V • 0...20 mA • 4...20 mA
Load resistor / load	> 5 k Ω for voltage output < 500 Ω for current output
Resolution	16 bits (including sign)
Output error	< 0.1% (ambient temperature 0 ... +55°C) < 0.2% (ambient temperature < 0°C and > 55°C) Based on the signal range end value in each case.
Largest short-term deviation during a specified electrical interference test	0.5 % of the full scale value of the signal range
Auxiliary voltage output	24 V _{DC} from the supply voltage U_P .

Housing data	
Dimensions W x H x D	30 mm x 126 mm x 26.5 mm (without connectors)
Weight	approx. 165 g
Installation position	variable
Material	PA6 (polyamide)

Environmental conditions	
Ambient temperature during operation	-25 ... +60 °C -25 ... +55 °C according to cULus
Ambient temperature during storage	-40 ... +85 °C
Vibration resistance, shock resistance	conforms to EN 60068-2-6 / EN 60068-2-27 Additional tests [► 11]
EMC immunity / emission	conforms to EN 61000-6-2 / EN 61000-6-4
Protection class	IP65, IP66, IP67 (conforms to EN 60529)

Approvals / markings	
Approvals / markings *)	CE, <u>cULus</u> [▶ 21]

*) Real applicable approvals/markings see type plate on the side (product marking).

Additional tests

The devices have undergone the following additional tests:

Test	Explanation
Vibration	10 frequency sweeps in 3 axes
	5 Hz < f < 60 Hz displacement 0.35 mm, constant amplitude
	60.1 Hz < f < 500 Hz acceleration 5 g, constant amplitude
Shocks	1000 shocks in each direction, in 3 axes
	35 g, 11 ms

3.3 Scope of supply

Make sure that the following components are included in the scope of delivery:

- 1x EPP4174-0002 EtherCAT P Box
- 2x protective cap for EtherCAT P socket, M8, red (pre-assembled)
- 10x labels, blank (1 strip of 10)

● Pre-assembled protective caps do not ensure IP67 protection

i Protective caps are pre-assembled at the factory to protect connectors during transport. They may not be tight enough to ensure IP67 protection.

Ensure that the protective caps are correctly seated to ensure IP67 protection.

3.4 Status LEDs

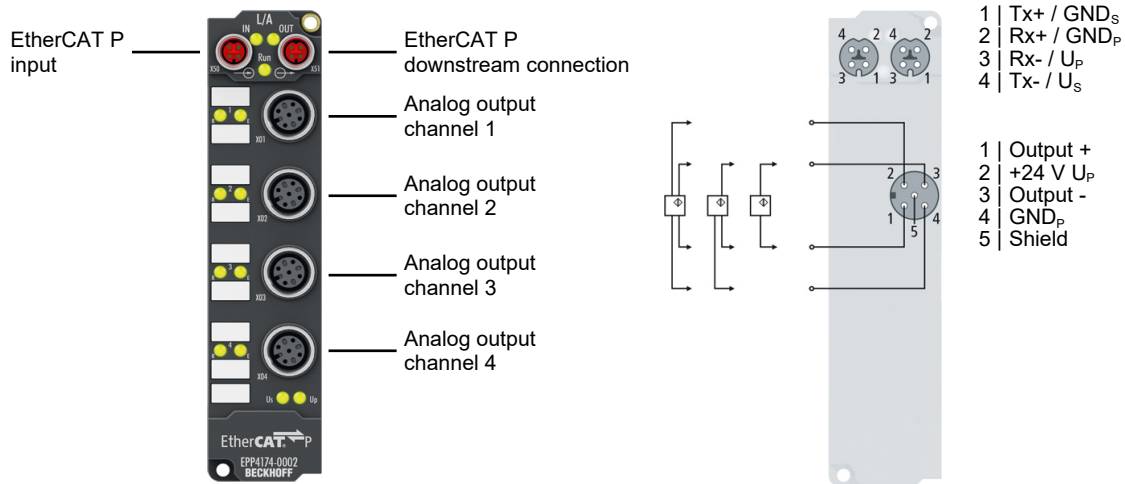

Status LEDs at the M12 connections

Connection	LED	Display	Meaning
M12 socket no. 1-4	R left	off	No data transfer to the D/A converter
		green	Data transfer to the D/A converter
	E right	off	Function OK
		red	Error: Broken wire or measured value outside the measuring range

Power supply

LED	Display	Meaning
Us	off	the power supply voltage, U _s , is not present
	green illuminated	the power supply voltage, U _s , is present
Up	off	the power supply voltage, U _p , is not present
	green illuminated	The power supply voltage, U _p , is present

3.5 Process image

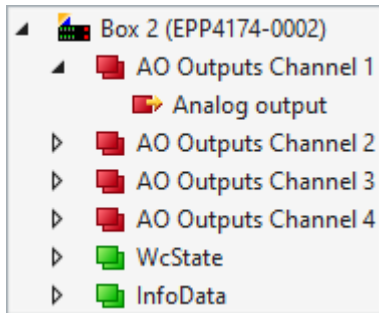

AO Outputs Channel 1

The data for the first analog channel can be found under **AO Outputs Channel 1**.

AO Outputs Channel 2 to 4

The data of analog channels 2 to 4 have the same structure as those of the first channel.

4 Mounting and connection

4.1 Mounting

4.1.1 Dimensions

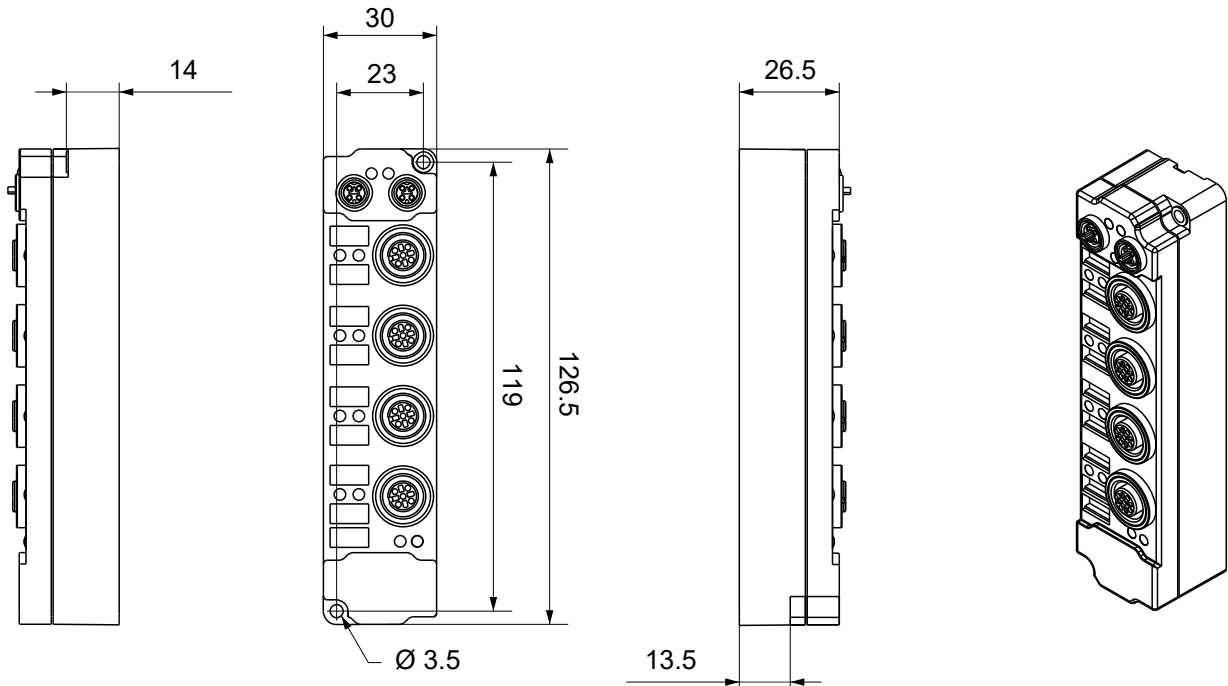

All dimensions are given in millimeters.
The drawing is not true to scale.

Housing features

Housing material	PA6 (polyamide)
Sealing compound	polyurethane
Mounting	two mounting holes $\varnothing 3.5$ mm for M3
Metal parts	brass, nickel-plated
Contacts	CuZn, gold-plated
Installation position	variable
Protection class	IP65, IP66, IP67 (conforms to EN 60529) when screwed together
Dimensions (H x W x D)	approx. 126 x 30 x 26.5 mm (without connectors)

4.1.2 Fixing

NOTICE

Dirt during assembly
 Dirty connectors can lead to malfunctions. Protection class IP67 can only be guaranteed if all cables and connectors are connected.

- Protect the plug connectors against dirt during the assembly.

Mount the module with two M3 screws on the mounting holes in the corners of the module. The mounting holes have no thread.

4.1.3 Functional earth (FE)

The upper mounting holes also serves as a connection for functional earth (FE).

Make sure that the box is grounded to low impedance via the functional earth (FE) connection. You can achieve this, for example, by mounting the box on a grounded machine bed.



Fig. 1: Connection for functional earth (FE)

4.1.4 Tightening torques for plug connectors

Screw connectors tight with a torque wrench. (e.g. ZB8801 from Beckhoff)

Connector diameter	Tightening torque
M8	0.4 Nm
M12	0.6 Nm

4.2 EtherCAT P

⚠ WARNING

Power supply from SELV/PELV power supply unit!

SELV/PELV circuits (Safety Extra Low Voltage, Protective Extra Low Voltage) according to IEC 61010-2-201 must be used to supply the EtherCAT P Power Sourcing Device (PSD).

Notes:

- SELV/PELV circuits may give rise to further requirements from standards such as IEC 60204-1 et al, for example with regard to cable spacing and insulation.
- A SELV (Safety Extra Low Voltage) supply provides safe electrical isolation and limitation of the voltage without a connection to the protective conductor, a PELV (Protective Extra Low Voltage) supply also requires a safe connection to the protective conductor.

⚠ CAUTION

Observe the UL requirements

- When operating under UL conditions, observe the warnings in the chapter [UL Requirements](#) [▶ 21].

EtherCAT P transmits two supply voltages:

- **Control voltage U_s**
The following sub-functions are supplied from the control voltage U_s :
 - the fieldbus
 - the processor logic
 - typically the inputs and the sensors if the EtherCAT P Box has inputs.
- **Peripheral voltage U_p**
The digital outputs are typically supplied from the peripheral voltage U_p for EtherCAT P Box modules with digital outputs. U_p can be supplied separately. If U_p is switched off, the fieldbus function, the function of the inputs and the supply of the sensors are maintained.

The exact assignment of U_s and U_p can be found in the pin assignment of the I/O connections.

Redirection of the supply voltages

The supply voltages are passed on internally from the "IN" connection to the "OUT" connection. Hence, the supply voltages U_s and U_p can be passed from one EtherCAT P Box to the next EtherCAT P Box in a simple manner.

NOTICE

Note the maximum current.

Ensure that the maximum permitted current of 3 A for the M8 connectors is not exceeded when redirecting EtherCAT P.

4.2.1 Connectors

NOTICE

Risk of damage to the device!
 Bring the EtherCAT/EtherCAT P system into a safe, powered down state before starting installation, disassembly or wiring of the modules!

Two M8 sockets at the upper end of the modules are provided for supply and downstream connection of EtherCAT P:

- IN: left M8 socket for EtherCAT P supply
- OUT: right M8 socket for downstream connection of EtherCAT P

The metal threads of the M8 EtherCAT P sockets are internally linked to the FE connection via high impedance RC combination. See chapter [Functional earth \(FE\)](#) [► 15].



Fig. 2: Connectors for EtherCAT P

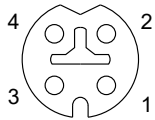

Fig. 3: M8 socket, p-coded

Contact	Signal	Voltage	Core color ¹⁾
1	Tx +	GND _S	yellow
2	Rx +	GND _P	white
3	Rx -	U _P : peripheral voltage, +24 V _{DC}	blue
4	Tx -	U _S : control voltage, +24 V _{DC}	orange
Housing	Shield	Shield	Shield

¹⁾ The core colors apply to EtherCAT P cables and ECP cables from Beckhoff.

4.2.2 Status LEDs

4.2.2.1 Supply voltages



EtherCAT P Box modules indicate the status of the supply voltages via two status LEDs. The status LEDs are labeled with the designations of the supply voltages: U_s and U_p.

LED	Display	Meaning
U _s (control voltage)	off	The supply voltage U _s is not available.
	green illuminated	The supply voltage U _s is available.
U _p (peripheral voltage)	off	The supply voltage U _p is not available.
	green illuminated	The supply voltage U _p is available.

4.2.2.2 EtherCAT



L/A (Link/Act)

A green LED labeled "L/A" or "Link/Act" is located next to each EtherCAT/EtherCAT P socket. The LED indicates the communication state of the respective socket:

LED	Meaning
off	no connection to the connected EtherCAT device
lit	LINK: connection to the connected EtherCAT device
flashes	ACT: communication with the connected EtherCAT device

Run

Each EtherCAT slave has a green LED labelled "Run". The LED signals the status of the slave in the EtherCAT network:

LED	Meaning
off	Slave is in "Init" state
flashes uniformly	Slave is in "Pre-Operational" state
flashes sporadically	Slave is in "Safe-Operational" state
lit	Slave is in "Operational" state

Description of the EtherCAT slave states

4.2.3 Conductor losses

Take into account the voltage drop on the supply line when planning a system. Avoid the voltage drop being so high that the supply voltage at the box lies below the minimum nominal voltage. Variations in the voltage of the power supply unit must also be taken into account.

i Planning tool for EtherCAT P

You can plan cable lengths, voltages and currents of your EtherCAT P system using TwinCAT 3. The requirement for this is TwinCAT 3 Build 4020 or higher.

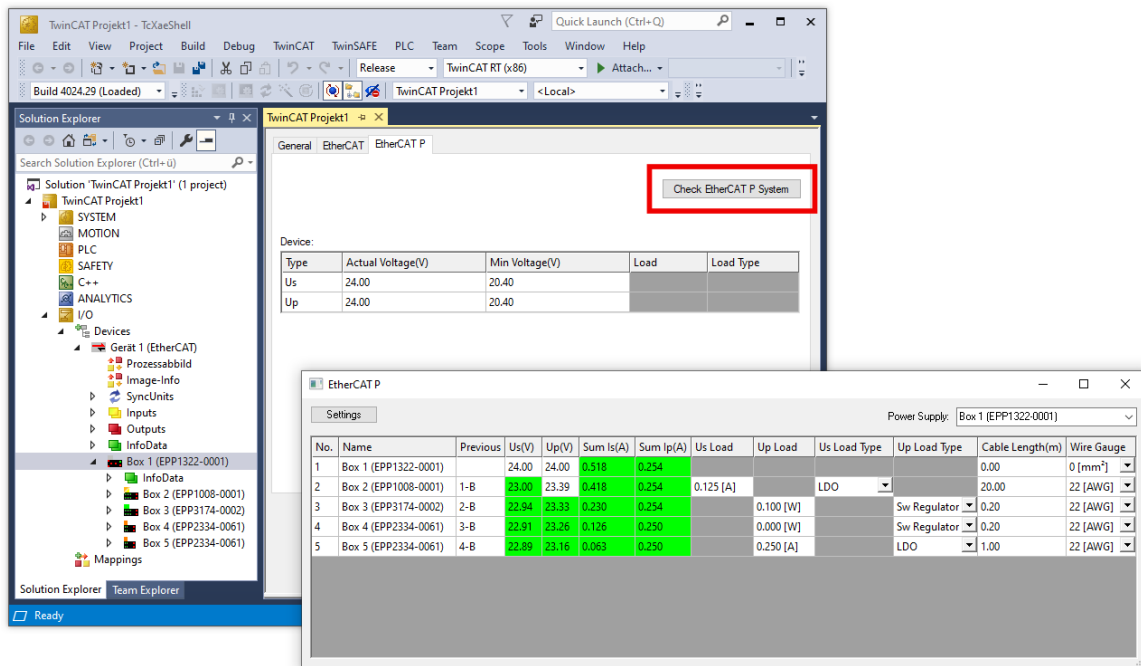

Further information can be found in the quick start guide [IO configuration in TwinCAT](#) in chapter "Configuration of EtherCAT P via TwinCAT".

Voltage drop on the supply line

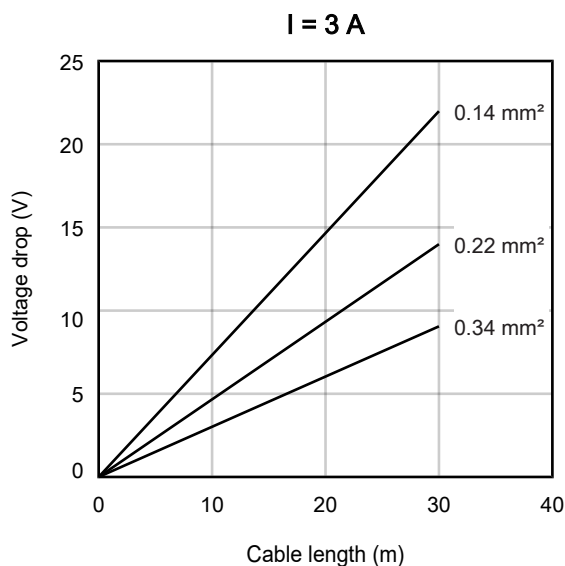

4.3 Signal connection

NOTICE

Supply and connection of sensors and actuators to EtherCAT P Box modules
 The connected sensors and actuators must be supplied by an EtherCAT P Box. GND_S and GND_P from one of the M8 / M12 signal connections of an EtherCAT P Box must not be connected to the machine bed.

● Supply of externally powered sensors or actuators
i If the sensors and actuators cannot be supplied from the EtherCAT P Box, the supply of externally powered sensors and actuators must be electrically isolated.

● EMC shield clamp
i Depending on the application it may be necessary to additionally attach the shield of the sensor cables at the signal inputs of the box with shield clamps ZB8513-0002.

See Chapter: "Accessories", section "Cables" [▶ 40].

The actuator is connected via Output + and Output -. The actuator can optionally be operated/supplied with 24 V_{DC}.

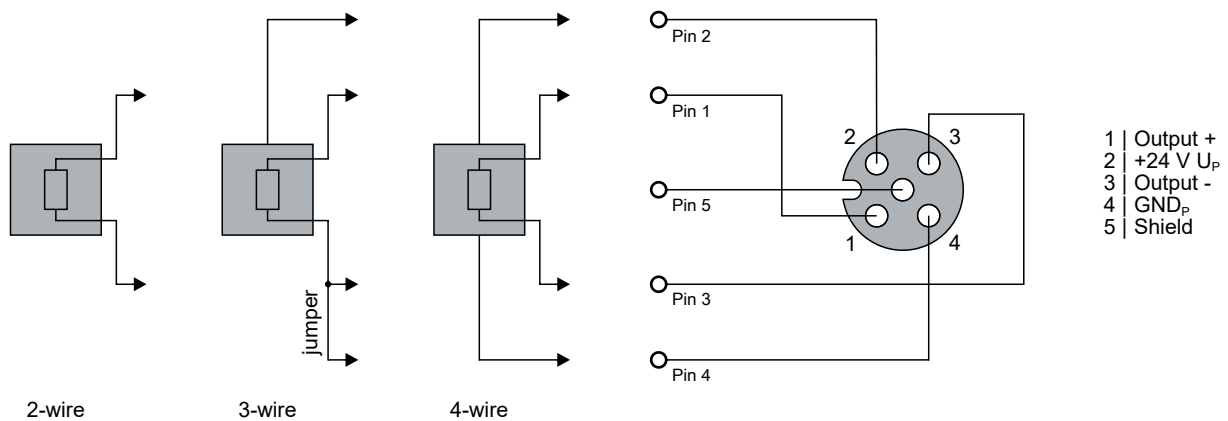

The ground potentials on pin 3 and pin 4 are electrically isolated. If the actuator requires a supply voltage and only has an earth connection, connect pin 3 and pin 4 with a jumper.

LED indicators - meanings

There is a green *Run* LED and a red *Error* LED for each channel. The green *Run* LED is lit when data are transferred to the D/A converter. The red *Error* LED indicates that there is an error (open circuit, measured value outside the range).

Correct function is indicated if the green *Run* LED is on and the red *Error* is off.



Fig. 4: Status and diagnostic LED at the M12 connector

4.4 UL Requirements

The installation of the EtherCAT Box Modules certified by UL has to meet the following requirements.

Supply voltage

⚠ CAUTION

CAUTION!

This UL requirements are valid for all supply voltages of all marked EtherCAT Box Modules!
For the compliance of the UL requirements the EtherCAT Box Modules should only be supplied

- by a 24 V_{DC} supply voltage, supplied by an isolating source and protected by means of a fuse (in accordance with UL248), rated maximum 4 Amp, or
- by a 24 V_{DC} power source, that has to satisfy *NEC class 2*.
A *NEC class 2* power supply shall not be connected in series or parallel with another (class 2) power source!

⚠ CAUTION

CAUTION!

To meet the UL requirements, the EtherCAT Box Modules must not be connected to unlimited power sources!

Networks

⚠ CAUTION

CAUTION!

To meet the UL requirements, EtherCAT Box Modules must not be connected to telecommunication networks!

Ambient temperature range

⚠ CAUTION

CAUTION!

To meet the UL requirements, EtherCAT Box Modules has to be operated only at an ambient temperature range of -25 °C to +55 °C!

Marking for UL

All EtherCAT Box Modules certified by UL (Underwriters Laboratories) are marked with the following label.



Fig. 5: UL label

4.5 Disposal



Products marked with a crossed-out wheeled bin shall not be discarded with the normal waste stream. The device is considered as waste electrical and electronic equipment. The national regulations for the disposal of waste electrical and electronic equipment must be observed.

5 Commissioning/Configuration

5.1 Integrating into a TwinCAT project

The procedure for integration in a TwinCAT project is described in these [Quick start guide](#).

5.2 Object overview

Index (hex)	Name	Flags	Default value
1000 ▶ 32]	Device type	RO	0x01901389 (26219401 _{dec})
1008 ▶ 32]	Device name	RO	EP4174-0002
1009 ▶ 32]	Hardware version	RO	00
100A ▶ 32]	Software version	RO	01
1011:0 ▶ 27]	Subindex 1011:01	RO RW	0x01 (1 _{dec}) 0x00000000 (0 _{dec})
1018:0 ▶ 32]	Subindex 1018:01 1018:02 1018:03 1018:04	RO RO RO RO	0x04 (4 _{dec}) 0x00000002 (2 _{dec}) 0x104E4052 (273563730 _{dec}) 0x00100002 (1048578 _{dec}) 0x00000000 (0 _{dec})
10F0:0 ▶ 32]	Subindex 10F0:01	RO RO	0x01 (1 _{dec}) 0x00000000 (0 _{dec})
1600:0 ▶ 32]	Subindex 1600:01	RO RO	0x01 (1 _{dec}) 0x7000:11, 16
1601:0 ▶ 33]	Subindex 1601:01	RO RO	0x01 (1 _{dec}) 0x7010:11, 16
1602:0 ▶ 33]	Subindex 1602:01	RO RO	0x01 (1 _{dec}) 0x7020:11, 16
1603:0 ▶ 33]	Subindex 1603:01	RO RO	0x01 (1 _{dec}) 0x7030:11, 16
1C00:0 ▶ 33]	Subindex 1C00:01 1C00:02 1C00:03 1C00:04	RO RO RO RO	0x04 (4 _{dec}) 0x01 (1 _{dec}) 0x02 (2 _{dec}) 0x03 (3 _{dec}) 0x04 (4 _{dec})
1C12:0 ▶ 33]	Subindex 1C12:01 1C12:02 1C12:03 1C12:04	RW RW RW RW	0x04 (4 _{dec}) 0x1600 (5632 _{dec}) 0x1601 (5633 _{dec}) 0x1602 (5634 _{dec}) 0x1603 (5635 _{dec})
1C13:0 ▶ 33]	Subindex	RW	0x00 (0 _{dec})
1C32:0 ▶ 34]	Subindex 1C32:01 1C32:02 1C32:03 1C32:04 1C32:05 1C32:06 1C32:07 1C32:08 1C32:09 1C32:0B 1C32:0C 1C32:0D 1C32:20	RO RW RW RO RO RO RO RW RO RO RO RO RO RO	0x20 (32 _{dec}) 0x0001 (1 _{dec}) 0x000F4240 (1000000 _{dec}) 0x00003A98 (15000 _{dec}) 0xC007 (49159 _{dec}) 0x000493E0 (300000 _{dec}) 0x00000000 (0 _{dec}) 0x00003A98 (15000 _{dec}) 0x0000 (0 _{dec}) 0x00003A98 (15000 _{dec}) 0x0000 (0 _{dec}) 0x0000 (0 _{dec}) 0x0000 (0 _{dec}) 0x00 (0 _{dec})

Index (hex)	Name	Flags	Default value
7000:0	Subindex AO outputs Ch.1	RO	0x11 (17 _{dec})
↳ 35]	7000:11 Analog output	RO	0x0000 (0 _{dec})
7010:0	Subindex AO outputs Ch.2	RO	0x11 (17 _{dec})
↳ 35]	7010:11 Analog output	RO	0x0000 (0 _{dec})
7020:0	Subindex AO outputs Ch.3	RO	0x11 (17 _{dec})
↳ 35]	7020:11 Analog output	RO	0x0000 (0 _{dec})
7030:0	Subindex AO outputs Ch.4	RO	0x11 (17 _{dec})
↳ 35]	7030:11 Analog output	RO	0x0000 (0 _{dec})
8000:0	Subindex AO settings Ch.1	RW	0x16 (22 _{dec})
↳ 28]	8000:01 Enable user scale	RW	0x00 (0 _{dec})
	8000:02 Presentation	RW	0x00 (0 _{dec})
	8000:05 Watchdog	RW	0x00 (0 _{dec})
	8000:07 Enable user calibration	RW	0x00 (0 _{dec})
	8000:08 Enable vendor calibration	RW	0x01 (1 _{dec})
	8000:11 User scale offset	RW	0x0000 (0 _{dec})
	8000:12 User scale gain	RW	0x00010000 (65536 _{dec})
	8000:13 Default output	RW	0x0000 (0 _{dec})
	8000:14 Default output ramp	RW	0xFFFF (65535 _{dec})
	8000:15 User calibration offset	RW	0x0000 (0 _{dec})
	8000:16 User calibration gain	RW	0x4000 (16384 _{dec})
800E:0	Subindex AO internal data Ch.1	RO	0x01 (1 _{dec})
↳ 35]	800E:01 DAC raw value	RO	0x0000 (0 _{dec})
800F:0	Subindex AO vendor data Ch.1	RW	0x06 (6 _{dec})
↳ 35]	800F:01 R0 Calibration Offset	RW	0x0000 (0 _{dec})
	800F:02 R0 Calibration Gain	RW	0x4000 (16384 _{dec})
	800F:03 R1 Calibration Offset	RW	0x0000 (0 _{dec})
	800F:04 R1 Calibration Gain	RW	0x4000 (16384 _{dec})
	800F:05 R2 Calibration Offset	RW	0x0000 (0 _{dec})
	800F:06 R2 Calibration Gain	RW	0x4000 (16384 _{dec})
8010:0	Subindex AO settings Ch.2	RW	0x16 (22 _{dec})
↳ 29]	8010:01 Enable user scale	RW	0x00 (0 _{dec})
	8010:02 Presentation	RW	0x00 (0 _{dec})
	8010:05 Watchdog	RW	0x00 (0 _{dec})
	8010:07 Enable user calibration	RW	0x00 (0 _{dec})
	8010:08 Enable vendor calibration	RW	0x01 (1 _{dec})
	8010:11 User scale offset	RW	0x0000 (0 _{dec})
	8010:12 User scale gain	RW	0x00010000 (65536 _{dec})
	8010:13 Default output	RW	0x0000 (0 _{dec})
	8010:14 Default output ramp	RW	0xFFFF (65535 _{dec})
	8010:15 User calibration offset	RW	0x0000 (0 _{dec})
	8010:16 User calibration gain	RW	0x4000 (16384 _{dec})
801E:0	Subindex AO internal data Ch.2	RO	0x01 (1 _{dec})
↳ 35]	801E:01 DAC raw value	RO	0x0000 (0 _{dec})
801F:0	Subindex AO vendor data Ch.2	RW	0x06 (6 _{dec})
↳ 36]	801F:01 R0 Calibration Offset	RW	0x0000 (0 _{dec})
	801F:02 R0 Calibration Gain	RW	0x4000 (16384 _{dec})
	801F:03 R1 Calibration Offset	RW	0x0000 (0 _{dec})
	801F:04 R1 Calibration Gain	RW	0x4000 (16384 _{dec})
	801F:05 R2 Calibration Offset	RW	0x0000 (0 _{dec})
	801F:06 R2 Calibration Gain	RW	0x4000 (16384 _{dec})
Index (hex)	Name	Flags	Default value
8020:0	Subindex AO settings Ch.3	RW	0x16 (22 _{dec})
↳ 30]	8020:01 Enable user scale	RW	0x00 (0 _{dec})
	8020:02 Presentation	RW	0x00 (0 _{dec})
	8020:05 Watchdog	RW	0x00 (0 _{dec})
	8020:07 Enable user calibration	RW	0x00 (0 _{dec})
	8020:08 Enable vendor calibration	RW	0x01 (1 _{dec})
	8020:11 User scale offset	RW	0x0000 (0 _{dec})

Index (hex)	Name	Flags	Default value	
	8020:12	User scale gain	RW	0x00010000 (65536 _{dec})
	8020:13	Default output	RW	0x0000 (0 _{dec})
	8020:14	Default output ramp	RW	0xFFFF (65535 _{dec})
	8020:15	User calibration offset	RW	0x0000 (0 _{dec})
	8020:16	User calibration gain	RW	0x4000 (16384 _{dec})
802E:0 [▶ 36]	Subindex	AO internal data Ch.3	RO	0x01 (1 _{dec})
	802E:01	DAC raw value	RO	0x0000 (0 _{dec})
802F:0 [▶ 36]	Subindex	AO vendor data Ch.3	RW	0x06 (6 _{dec})
	802F:01	R0 Calibration Offset	RW	0x0000 (0 _{dec})
	802F:02	R0 Calibration Gain	RW	0x4000 (16384 _{dec})
	802F:03	R1 Calibration Offset	RW	0x0000 (0 _{dec})
	802F:04	R1 Calibration Gain	RW	0x4000 (16384 _{dec})
	802F:05	R2 Calibration Offset	RW	0x0000 (0 _{dec})
	802F:06	R2 Calibration Gain	RW	0x4000 (16384 _{dec})
8030:0 [▶ 31]	Subindex	AO settings Ch.4	RW	0x16 (22 _{dec})
	8030:01	Enable user scale	RW	0x00 (0 _{dec})
	8030:02	Presentation	RW	0x00 (0 _{dec})
	8030:05	Watchdog	RW	0x00 (0 _{dec})
	8030:07	Enable user calibration	RW	0x00 (0 _{dec})
	8030:08	Enable vendor calibration	RW	0x01 (1 _{dec})
	8030:11	User scale offset	RW	0x0000 (0 _{dec})
	8030:12	User scale gain	RW	0x00010000 (65536 _{dec})
	8030:13	Default output	RW	0x0000 (0 _{dec})
	8030:14	Default output ramp	RW	0xFFFF (65535 _{dec})
	8030:15	User calibration offset	RW	0x0000 (0 _{dec})
	8030:16	User calibration gain	RW	0x4000 (16384 _{dec})
803E:0 [▶ 36]	Subindex	AO internal data Ch.4	RO	0x01 (1 _{dec})
	803E:01	DAC raw value	RO	0x0000 (0 _{dec})
803F:0 [▶ 36]	Subindex	AO vendor data Ch.4	RW	0x06 (6 _{dec})
	803F:01	R0 Calibration Offset	RW	0x0000 (0 _{dec})
	803F:02	R0 Calibration Gain	RW	0x4000 (16384 _{dec})
	803F:03	R1 Calibration Offset	RW	0x0000 (0 _{dec})
	803F:04	R1 Calibration Gain	RW	0x4000 (16384 _{dec})
	803F:05	R2 Calibration Offset	RW	0x0000 (0 _{dec})
	803F:06	R2 Calibration Gain	RW	0x4000 (16384 _{dec})
F000:0 [▶ 36]	Subindex	Modular device profile	RO	0x02 (2 _{dec})
	F000:01	Module index distance	RO	0x0010 (16 _{dec})
	F000:02	Maximum number of modules	RO	0x0004 (4 _{dec})
F008 [▶ 37]		Code word	RW	0x00000000 (0 _{dec})
F010:0 [▶ 37]	Subindex	Module list	RW	0x04 (4 _{dec})
	F010:01	SubIndex 001	RW	0x00000190 (400 _{dec})
	F010:02	SubIndex 002	RW	0x00000190 (400 _{dec})
	F010:03	SubIndex 003	RW	0x00000190 (400 _{dec})
	F010:04	SubIndex 004	RW	0x00000190 (400 _{dec})
F800:0 [▶ 31]	Subindex	AO Range Settings	RW	0x04 (4 _{dec})
	F800:01	Output type Ch1	RW	0x0000 (0 _{dec})
	F800:02	Output type Ch2	RW	0x0000 (0 _{dec})
	F800:03	Output type Ch3	RW	0x0000 (0 _{dec})
	F800:04	Output type Ch4	RW	0x0000 (0 _{dec})

Legend

Flags:

RO (Read Only): this object can be read only

RW (Read/Write): this object can be read and written to

5.3 Object description and parameterization

Introduction

The CoE overview contains objects for different intended applications:

- [Objects required for parameterization \[▶ 27\]](#) during commissioning
- [Objects intended for regular operation \[▶ 32\]](#), e. g. through ADS access.
- [Objects for indicating internal settings \[▶ 32\]](#) (may be fixed)
- Further [profile-specific objects \[▶ 35\]](#) indicating inputs, outputs and status information

The following section first describes the objects required for normal operation, followed by a complete overview of missing objects.

5.3.1 Objects to be parameterized during commissioning

Index 1011 Restore default parameters

Index (hex)	Name	Meaning	Data type	Flags	Default
1011:0	Restore default parameters	Restore default parameters	UINT8	RO	0x01 (1 _{dec})
1011:01	SubIndex 001	If this object is set to " 0x64616F6C " in the set value dialog, all backup objects are reset to their delivery state.	UINT32	RW	0x00000000 (0 _{dec})

Index 8000 AO settings Ch.1

Index (hex)	Name	Meaning	Data type	Flags	Default	
8000:0	AO settings Ch.1	Maximum subindex	UINT8	RO	0x16 (22 _{dec})	
8000:01	Enable user scale	This entry activates the scaling for 0x8pp0:11 and 0x8pp0:12.	BOOLEAN	RW	0x00 (0 _{dec})	
8000:02	Presentation	0	Signed presentation The output value range 0x7pp1:11 is shown as 16 bit signed integer. For unipolar terminals (0-10V or 0-20 mA) the negative range is set to zero.	BIT3	RW	0x00 (0 _{dec})
		1	Unsigned presentation The output value range 0x7pp1:11 is shown as 16 bit unsigned integer. Negative values are not possible.			
		2	Absolute value with MSB as sign Signed amount representation is active.			
		3	Absolute value The absolute value of the signed representation is formed.			
8000:05	Watchdog	0	Default watchdog value The default value (0x8pp0:13) is active.	BIT2	RW	0x00 (0 _{dec})
		1	Watchdog ramp The ramp (0x8pp0:14) for moving to the default value ((0x8pp0:13)) is active.			
		2	Last output value In the event of an error (triggering of the watchdog) the last process data is output.			
8000:07	Enable user calibration	Enables user calibration	BOOLEAN	RW	0x00 (0 _{dec})	
8000:08	Enable vendor calibration	Enable vendor calibration	BOOLEAN	RW	0x01 (1 _{dec})	
8000:11	User scale offset	User scaling: Offset	INT16	RW	0x0000 (0 _{dec})	
8000:12	User scale gain	User scaling: Gain. The gain is represented in fixed-point format, with the factor 2 ⁻¹⁶ . The value one corresponds to 65535 (0x00010000).	INT32	RW	0x00010000 (65536 _{dec})	
8000:13	Default output	Default output value	INT16	RW	0x0000 (0 _{dec})	
8000:14	Default output ramp	This value defines the ramps for the ramp-down to the default value. The value is specified in digits / ms. If the entry is 100 and the default value 0, for example, it takes 327 ms (32767/100) for the output value to change from the maximum value (32767) to the default value in the event of a fault.	UINT16	RW	0xFFFF (65535 _{dec})	
8000:15	User calibration offset	User calibration: Offset	INT16	RW	0x0000 (0 _{dec})	
8000:16	User calibration gain	User calibration: Gain	UINT16	RW	0x4000 (16384 _{dec})	

Index 8010 AO settings Ch.2

Index (hex)	Name	Meaning	Data type	Flags	Default	
8010:0	AO settings Ch.2	Maximum subindex	UINT8	RO	0x16 (22 _{dec})	
8010:01	Enable user scale	This entry activates the scaling for 0x8pp0:11 and 0x8pp0:12.	BOOLEAN	RW	0x00 (0 _{dec})	
8010:02	Presentation	0	Signed presentation The output value range 0x7pp1:11 is shown as 16 bit signed integer. For unipolar terminals (0-10V or 0-20 mA) the negative range is set to zero.	BIT3	RW	0x00 (0 _{dec})
		1	Unsigned presentation The output value range 0x7pp1:11 is shown as 16 bit unsigned integer. Negative values are not possible.			
		2	Absolute value with MSB as sign Signed amount representation is active.			
		3	Absolute value The absolute value of the signed representation is formed.			
8010:05	Watchdog	0	Default watchdog value The default value (0x8pp0:13) is active.	BIT2	RW	0x00 (0 _{dec})
		1	Watchdog ramp The ramp (0x8pp0:14) for moving to the default value ((0x8pp0:13)) is active.			
		2	Last output value In the event of an error (triggering of the watchdog) the last process data is output.			
8010:07	Enable user calibration	Enables user calibration	BOOLEAN	RW	0x00 (0 _{dec})	
8010:08	Enable vendor calibration	Enable vendor calibration	BOOLEAN	RW	0x01 (1 _{dec})	
8010:11	User scale offset	User scaling: Offset	INT16	RW	0x0000 (0 _{dec})	
8010:12	User scale gain	User scaling: Gain. The gain is represented in fixed-point format, with the factor 2 ⁻¹⁶ . The value one corresponds to 65535 (0x00010000).	INT32	RW	0x00010000 (65536 _{dec})	
8010:13	Default output	Default output value	INT16	RW	0x0000 (0 _{dec})	
8010:14	Default output ramp	This value defines the ramps for the ramp-down to the default value. The value is specified in digits / ms. If the entry is 100 and the default value 0, for example, it takes 327 ms (32767/100) for the output value to change from the maximum value (32767) to the default value in the event of a fault.	UINT16	RW	0xFFFF (65535 _{dec})	
8010:15	User calibration offset	User calibration: Offset	INT16	RW	0x0000 (0 _{dec})	
8010:16	User calibration gain	User calibration: Gain	UINT16	RW	0x4000 (16384 _{dec})	

Index 8020 AO settings Ch.3

Index (hex)	Name	Meaning	Data type	Flags	Default	
8020:0	AO settings Ch.3	Maximum subindex	UINT8	RO	0x16 (22 _{dec})	
8020:01	Enable user scale	This entry activates the scaling for 0x8pp0:11 and 0x8pp0:12.	BOOLEAN	RW	0x00 (0 _{dec})	
8020:02	Presentation	0	Signed presentation The output value range 0x7pp1:11 is shown as 16 bit signed integer. For unipolar terminals (0-10V or 0-20 mA) the negative range is set to zero.	BIT3	RW	0x00 (0 _{dec})
		1	Unsigned presentation The output value range 0x7pp1:11 is shown as 16 bit unsigned integer. Negative values are not possible.			
		2	Absolute value with MSB as sign Signed amount representation is active.			
		3	Absolute value The absolute value of the signed representation is formed.			
8020:05	Watchdog	0	Default watchdog value The default value (0x8pp0:13) is active.	BIT2	RW	0x00 (0 _{dec})
		1	Watchdog ramp The ramp (0x8pp0:14) for moving to the default value ((0x8pp0:13)) is active.			
		2	Last output value In the event of an error (triggering of the watchdog) the last process data is output.			
8020:07	Enable user calibration	Enables user calibration	BOOLEAN	RW	0x00 (0 _{dec})	
8020:08	Enable vendor calibration	Enable vendor calibration	BOOLEAN	RW	0x01 (1 _{dec})	
8020:11	User scale offset	User scaling: Offset	INT16	RW	0x0000 (0 _{dec})	
8020:12	User scale gain	User scaling: Gain. The gain is represented in fixed-point format, with the factor 2 ⁻¹⁶ . The value one corresponds to 65535 (0x00010000).	INT32	RW	0x00010000 (65536 _{dec})	
8020:13	Default output	Default output value	INT16	RW	0x0000 (0 _{dec})	
8020:14	Default output ramp	This value defines the ramps for the ramp-down to the default value. The value is specified in digits / ms. If the entry is 100 and the default value 0, for example, it takes 327 ms (32767/100) for the output value to change from the maximum value (32767) to the default value in the event of a fault.	UINT16	RW	0xFFFF (65535 _{dec})	
8020:15	User calibration offset	User calibration: Offset	INT16	RW	0x0000 (0 _{dec})	
8020:16	User calibration gain	User calibration: Gain	UINT16	RW	0x4000 (16384 _{dec})	

Index 8030 AO settings Ch.4

Index (hex)	Name	Meaning	Data type	Flags	Default	
8030:0	AO settings Ch.4	Maximum subindex	UINT8	RO	0x16 (22 _{dec})	
8030:01	Enable user scale	This entry activates the scaling for 0x8pp0:11 and 0x8pp0:12.	BOOLEAN	RW	0x00 (0 _{dec})	
8030:02	Presentation	0	Signed presentation The output value range 0x7pp1:11 is shown as 16 bit signed integer. For unipolar terminals (0-10V or 0-20 mA) the negative range is set to zero.	BIT3	RW	0x00 (0 _{dec})
		1	Unsigned presentation The output value range 0x7pp1:11 is shown as 16 bit unsigned integer. Negative values are not possible.			
		2	Absolute value with MSB as sign Signed amount representation is active.			
		3	Absolute value The absolute value of the signed representation is formed.			
8030:05	Watchdog	0	Default watchdog value The default value (0x8pp0:13) is active.	BIT2	RW	0x00 (0 _{dec})
		1	Watchdog ramp The ramp (0x8pp0:14) for moving to the default value ((0x8pp0:13)) is active.			
		2	Last output value In the event of an error (triggering of the watchdog) the last process data is output.			
8030:07	Enable user calibration	Enables user calibration	BOOLEAN	RW	0x00 (0 _{dec})	
8030:08	Enable vendor calibration	Enable vendor calibration	BOOLEAN	RW	0x01 (1 _{dec})	
8030:11	User scale offset	User scaling: Offset	INT16	RW	0x0000 (0 _{dec})	
8030:12	User scale gain	User scaling: Gain. The gain is represented in fixed-point format, with the factor 2 ⁻¹⁶ . The value one corresponds to 65535 (0x00010000).	INT32	RW	0x00010000 (65536 _{dec})	
8030:13	Default output	Default output value	INT16	RW	0x0000 (0 _{dec})	
8030:14	Default output ramp	This value defines the ramps for the ramp-down to the default value. The value is specified in digits / ms. If the entry is 100 and the default value 0, for example, it takes 327 ms (32767/100) for the output value to change from the maximum value (32767) to the default value in the event of a fault.	UINT16	RW	0xFFFF (65535 _{dec})	
8030:15	User calibration offset	User calibration: Offset	INT16	RW	0x0000 (0 _{dec})	
8030:16	User calibration gain	User calibration: Gain	UINT16	RW	0x4000 (16384 _{dec})	

Index F800 AO Range Settings

Index (hex)	Name	Meaning	Data type	Flags	Default	
F800:0	AO Range Settings	Maximum subindex	UINT8	RO	0x04 (4 _{dec})	
F800:01	Output type Ch1	Output signal range for channel 1		UINT16	RW	0x0000 (0 _{dec})
		0	-10...+10 V			
		1	0...20 mA			
		2	4...20 mA			
		6	0...10 V			
F800:02	Output type Ch2	Output signal range for channel 2 (values see channel 1)	UINT16	RW	0x0000 (0 _{dec})	
F800:03	Output type Ch3	Output signal range for channel 3 (values see channel 1)	UINT16	RW	0x0000 (0 _{dec})	
F800:04	Output type Ch4	Output signal range for channel 4 (values see channel 1)	UINT16	RW	0x0000 (0 _{dec})	

5.3.2 Objects for regular operation

The EP4174 has no such objects.

5.3.3 Standard objects (0x1000-0x1FFF)

The standard objects have the same meaning for all EtherCAT slaves.

Index 1000 Device type

Index (hex)	Name	Meaning	Data type	Flags	Default
1000:0	Device type	Device type of the EtherCAT slave: The Lo-Word contains the CoE profile used (5001). The Hi-Word contains the module profile according to the modular device profile.	UINT32	RO	0x01901389 (26219401 _{dec})

Index 1008 Device name

Index (hex)	Name	Meaning	Data type	Flags	Default
1008:0	Device name	Device name of the EtherCAT slave	STRING	RO	EPP4174-0002

Index 1009 Hardware version

Index (hex)	Name	Meaning	Data type	Flags	Default
1009:0	Hardware version	Hardware version of the EtherCAT slave	STRING	RO	00

Index 100A Software version

Index (hex)	Name	Meaning	Data type	Flags	Default
100A:0	Software version	Firmware version of the EtherCAT slave	STRING	RO	01

Index 1018 Identity

Index (hex)	Name	Meaning	Data type	Flags	Default
1018:0	Identity	Information for identifying the slave	UINT8	RO	0x04 (4 _{dec})
1018:01	Vendor ID	Vendor ID of the EtherCAT slave	UINT32	RO	0x00000002 (2 _{dec})
1018:02	Product code	Product code of the EtherCAT slave	UINT32	RO	0x6476CAE9 (1685506793 _{dec})
1018:03	Revision	Revision number of the EtherCAT slave; the low word (bit 0-15) indicates the special terminal number, the high word (bit 16-31) refers to the device description	UINT32	RO	0x00100002 (1048578 _{dec})
1018:04	Serial number	Serial number of the EtherCAT slave; the low byte (bit 0-7) of the low word contains the year of production, the high byte (bit 8-15) of the low word contains the week of production, the high word (bit 16-31) is 0	UINT32	RO	0x00000000 (0 _{dec})

Index 10F0 Backup parameter handling

Index (hex)	Name	Meaning	Data type	Flags	Default
10F0:0	Backup parameter handling	Information for standardized loading and saving of backup entries	UINT8	RO	0x01 (1 _{dec})
10F0:01	Checksum	Checksum across all backup entries of the EtherCAT slave	UINT32	RO	0x00000000 (0 _{dec})

Index 1600 AO RxPDO-Map Ch.1

Index (hex)	Name	Meaning	Data type	Flags	Default
1600:0	AO RxPDO-Map Ch.1	PDO Mapping RxPDO 1	UINT8	RO	0x01 (1 _{dec})
1600:01	SubIndex 001	1. PDO Mapping entry (object 0x7000 (AO outputs Ch.1), entry 0x11 (Analog output))	UINT32	RO	0x7000:11, 16

Index 1601 AO RxPDO-Map Ch.2

Index (hex)	Name	Meaning	Data type	Flags	Default
1601:0	AO RxPDO-Map Ch.2	PDO Mapping RxPDO 2	UINT8	RO	0x01 (1 _{dec})
1601:01	SubIndex 001	1. PDO Mapping entry (object 0x7010 (AO outputs Ch.2), entry 0x11 (Analog output))	UINT32	RO	0x7010:11, 16

Index 1602 AO RxPDO-Map Ch.3

Index (hex)	Name	Meaning	Data type	Flags	Default
1602:0	AO RxPDO-Map Ch.3	PDO Mapping RxPDO 3	UINT8	RO	0x01 (1 _{dec})
1602:01	SubIndex 001	1. PDO Mapping entry (object 0x7020 (AO outputs Ch.3), entry 0x11 (Analog output))	UINT32	RO	0x7020:11, 16

Index 1603 AO RxPDO-Map Ch.4

Index (hex)	Name	Meaning	Data type	Flags	Default
1603:0	AO RxPDO-Map Ch.4	PDO Mapping RxPDO 4	UINT8	RO	0x01 (1 _{dec})
1603:01	SubIndex 001	1. PDO Mapping entry (object 0x7030 (AO outputs Ch.4), entry 0x11 (Analog output))	UINT32	RO	0x7030:11, 16

Index 1C00 Sync manager type

Index (hex)	Name	Meaning	Data type	Flags	Default
1C00:0	Sync manager type	Using the sync managers	UINT8	RO	0x04 (4 _{dec})
1C00:01	SubIndex 001	Sync-Manager Type Channel 1: Mailbox Write	UINT8	RO	0x01 (1 _{dec})
1C00:02	SubIndex 002	Sync-Manager Type Channel 2: Mailbox Read	UINT8	RO	0x02 (2 _{dec})
1C00:03	SubIndex 003	Sync-Manager Type Channel 3: Process Data Write (Outputs)	UINT8	RO	0x03 (3 _{dec})
1C00:04	SubIndex 004	Sync-Manager Type Channel 4: Process Data Read (Inputs)	UINT8	RO	0x04 (4 _{dec})

Index 1C12 RxPDO assign

Index (hex)	Name	Meaning	Data type	Flags	Default
1C12:0	RxPDO assign	PDO Assign Outputs	UINT8	RW	0x04 (4 _{dec})
1C12:01	Subindex 001	1. allocated RxPDO (contains the index of the associated RxPDO mapping object)	UINT16	RW	0x1600 (5632 _{dec})
1C12:02	Subindex 002	2. allocated RxPDO (contains the index of the associated RxPDO mapping object)	UINT16	RW	0x1601 (5633 _{dec})
1C12:03	Subindex 003	3. allocated RxPDO (contains the index of the associated RxPDO mapping object)	UINT16	RW	0x1602 (5634 _{dec})
1C12:04	Subindex 004	4. allocated RxPDO (contains the index of the associated RxPDO mapping object)	UINT16	RW	0x1603 (5635 _{dec})

Index 1C13 TxPDO assign

Index (hex)	Name	Meaning	Data type	Flags	Default
1C13:0	TxPDO assign	PDO Assign Inputs	UINT8	RW	0x00 (0 _{dec})

Index 1C32 SM output parameter

Index (hex)	Name	Meaning	Data type	Flags	Default	
1C32:0	SM output parameter	Synchronization parameters for the outputs	UINT8	RO	0x20 (32 _{dec})	
1C32:01	Sync mode	Value Current synchronization mode	UINT16	RW	0x0001 (1 _{dec})	
		0 Free Run				
		1 Synchron with SM 2 Event				
		2 DC-Mode - Synchron with SYNC0 Event				
		3 DC-Mode - Synchron with SYNC1 Event				
1C32:02	Cycle time	Cycle time (in ns):	UINT32	RW	0x000F4240 (1000000 _{dec})	
		Free Run				Cycle time of the local timer
		Synchron with SM 2 Event				Master cycle time
		DC-Mode				SYNC0/SYNC1 Cycle Time
1C32:03	Shift time	Time between SYNC0 event and output of the outputs (in ns, DC mode only)	UINT32	RO	0x00003A98 (15000 _{dec})	
1C32:04	Sync modes supported	Bit Value Supported synchronization modes:	UINT16	RO	0xC007 (49159 _{dec})	
		0 1 free run is supported				
		1 1 Synchronous with SM 2 event is supported				
		3.2 01 DC mode is supported				
		5.4 10 Output shift with SYNC1 event (only DC mode)				
14 1 dynamic times (measurement through writing of 0x1C32:08 [▶ 34])						
1C32:05	Minimum cycle time	Minimum cycle time (in ns)	UINT32	RO	0x000493E0 (300000 _{dec})	
1C32:06	Calc and copy time	Minimum time between SYNC0 and SYNC1 event (in ns, DC mode only)	UINT32	RO	0x00000000 (0 _{dec})	
1C32:07	Minimum delay time		UINT32	RO	0x00003A98 (15000 _{dec})	
1C32:08	Command	0 Measurement of the local cycle time is stopped	UINT16	RW	0x0000 (0 _{dec})	
		1 Measurement of the local cycle time is started				
		The entries 0x1C32:03 [▶ 34], 0x1C32:05 [▶ 34], 0x1C32:06 [▶ 34], 0x1C32:09 [▶ 34], 0x1C33:03, 0x1C33:06 [▶ 34], 0x1C33:09				
1C32:09	Maximum Delay time	Time between SYNC1 event and output of the outputs (in ns, DC mode only)	UINT32	RO	0x00003A98 (15000 _{dec})	
1C32:0B	SM event missed counter	Number of missed SM events in OPERATIONAL (DC mode only)	UINT16	RO	0x0000 (0 _{dec})	
1C32:0C	Cycle exceeded counter	Number of occasions the cycle time was exceeded in OPERATIONAL (cycle was not completed in time or the next cycle began too early)	UINT16	RO	0x0000 (0 _{dec})	
1C32:0D	Shift too short counter	Number of occasions that the interval between SYNC0 and SYNC1 event was too short (DC mode only)	UINT16	RO	0x0000 (0 _{dec})	
1C32:20	Sync error	The synchronization was not correct in the last cycle (outputs were output too late; DC mode only)	BOOLEAN	RO	0x00 (0 _{dec})	

5.3.4 Profile-specific objects (0x6000-0xFFFF)

The profile-specific objects have the same meaning for all EtherCAT slaves that support the profile 5001.

Index 7000 AO outputs Ch.1

Index (hex)	Name	Meaning	Data type	Flags	Default
7000:0	AO outputs Ch.1		UINT8	RO	0x11 (17 _{dec})
7000:11	Analog output	Analog output data	INT16	RO	0x0000 (0 _{dec})

Index 7010 AO outputs Ch.2

Index (hex)	Name	Meaning	Data type	Flags	Default
7010:0	AO outputs Ch.2		UINT8	RO	0x11 (17 _{dec})
7010:11	Analog output	Analog output data	INT16	RO	0x0000 (0 _{dec})

Index 7020 AO outputs Ch.3

Index (hex)	Name	Meaning	Data type	Flags	Default
7020:0	AO outputs Ch.3		UINT8	RO	0x11 (17 _{dec})
7020:11	Analog output	Analog output data	INT16	RO	0x0000 (0 _{dec})

Index 7030 AO outputs Ch.4

Index (hex)	Name	Meaning	Data type	Flags	Default
7030:0	AO outputs Ch.4		UINT8	RO	0x11 (17 _{dec})
7030:11	Analog output	Analog output data	INT16	RO	0x0000 (0 _{dec})

Index 800E AO internal data Ch.1

Index (hex)	Name	Meaning	Data type	Flags	Default
800E:0	AO internal data Ch.1		UINT8	RO	0x01 (1 _{dec})
800E:01	DAC raw value	Raw value of the D/A converter	UINT16	RO	0x0000 (0 _{dec})

Index 800F AO vendor data Ch.1

Index (hex)	Name	Meaning	Data type	Flags	Default
800F:0	AO vendor data Ch.1		UINT8	RO	0x06 (6 _{dec})
800F:01	R0 Calibration Offset	Vendor calibration: Offset for +/-10 V	INT16	RW	0x0000 (0 _{dec})
800F:02	R0 Calibration Gain	Vendor calibration: Gain for +/-10 V	UINT16	RW	0x4000 (16384 _{dec})
800F:03	R1 Calibration Offset	Vendor calibration: Offset for 0-20 mA	INT16	RW	0x0000 (0 _{dec})
800F:04	R1 Calibration Gain	Vendor calibration: Gain for 0-20 mA	UINT16	RW	0x4000 (16384 _{dec})
800F:05	R2 Calibration Offset	Vendor calibration: Offset for 4-20 mA	INT16	RW	0x0000 (0 _{dec})
800F:06	R2 Calibration Gain	Vendor calibration: Gain for 4-20 mA	UINT16	RW	0x4000 (16384 _{dec})

Index 801E AO internal data Ch.2

Index (hex)	Name	Meaning	Data type	Flags	Default
801E:0	AO internal data Ch.2		UINT8	RO	0x01 (1 _{dec})
801E:01	DAC raw value	Raw value of the D/A converter	UINT16	RO	0x0000 (0 _{dec})

Index 801F AO vendor data Ch.2

Index (hex)	Name	Meaning	Data type	Flags	Default
801F:0	AO vendor data Ch.2		UINT8	RO	0x06 (6 _{dec})
801F:01	R0 Calibration Offset	Vendor calibration: Offset for +/-10 V	INT16	RW	0x0000 (0 _{dec})
801F:02	R0 Calibration Gain	Vendor calibration: Gain for +/-10 V	UINT16	RW	0x4000 (16384 _{dec})
801F:03	R1 Calibration Offset	Vendor calibration: Offset for 0-20 mA	INT16	RW	0x0000 (0 _{dec})
801F:04	R1 Calibration Gain	Vendor calibration: Gain for 0-20 mA	UINT16	RW	0x4000 (16384 _{dec})
801F:05	R2 Calibration Offset	Vendor calibration: Offset for 4-20 mA	INT16	RW	0x0000 (0 _{dec})
801F:06	R2 Calibration Gain	Vendor calibration: Gain for 4-20 mA	UINT16	RW	0x4000 (16384 _{dec})

Index 802E AO internal data Ch.3

Index (hex)	Name	Meaning	Data type	Flags	Default
802E:0	AO internal data Ch.3		UINT8	RO	0x01 (1 _{dec})
802E:01	DAC raw value	Raw value of the D/A converter	UINT16	RO	0x0000 (0 _{dec})

Index 802F AO vendor data Ch.3

Index (hex)	Name	Meaning	Data type	Flags	Default
802F:0	AO vendor data Ch.3		UINT8	RO	0x06 (6 _{dec})
802F:01	R0 Calibration Offset	Vendor calibration: Offset for +/-10 V	INT16	RW	0x0000 (0 _{dec})
802F:02	R0 Calibration Gain	Vendor calibration: Gain for +/-10 V	UINT16	RW	0x4000 (16384 _{dec})
802F:03	R1 Calibration Offset	Vendor calibration: Offset for 0-20 mA	INT16	RW	0x0000 (0 _{dec})
802F:04	R1 Calibration Gain	Vendor calibration: Gain for 0-20 mA	UINT16	RW	0x4000 (16384 _{dec})
802F:05	R2 Calibration Offset	Vendor calibration: Offset for 4-20 mA	INT16	RW	0x0000 (0 _{dec})
802F:06	R2 Calibration Gain	Vendor calibration: Gain for 4-20 mA	UINT16	RW	0x4000 (16384 _{dec})

Index 803E AO internal data Ch.4

Index (hex)	Name	Meaning	Data type	Flags	Default
803E:0	AO internal data Ch.4		UINT8	RO	0x01 (1 _{dec})
803E:01	DAC raw value	Raw value of the D/A converter	UINT16	RO	0x0000 (0 _{dec})

Index 803F AO vendor data Ch.4

Index (hex)	Name	Meaning	Data type	Flags	Default
803F:0	AO vendor data Ch.4		UINT8	RO	0x06 (6 _{dec})
803F:01	R0 Calibration Offset	Vendor calibration: Offset for +/-10 V	INT16	RW	0x0000 (0 _{dec})
803F:02	R0 Calibration Gain	Vendor calibration: Gain for +/-10 V	UINT16	RW	0x4000 (16384 _{dec})
803F:03	R1 Calibration Offset	Vendor calibration: Offset for 0-20 mA	INT16	RW	0x0000 (0 _{dec})
803F:04	R1 Calibration Gain	Vendor calibration: Gain for 0-20 mA	UINT16	RW	0x4000 (16384 _{dec})
803F:05	R2 Calibration Offset	Vendor calibration: Offset for 4-20 mA	INT16	RW	0x0000 (0 _{dec})
803F:06	R2 Calibration Gain	Vendor calibration: Gain for 4-20 mA	UINT16	RW	0x4000 (16384 _{dec})

Index F000 Modular device profile

Index (hex)	Name	Meaning	Data type	Flags	Default
F000:0	Modular device profile	General information for the modular device profile	UINT8	RO	0x02 (2 _{dec})
F000:01	Module index distance	Index distance of the objects of the individual channels	UINT16	RO	0x0010 (16 _{dec})
F000:02	Maximum number of modules	Number of channels	UINT16	RO	0x0004 (4 _{dec})

Index F008 Code word

Index (hex)	Name	Meaning	Data type	Flags	Default
F008:0	Code word		UINT32	RW	0x00000000 (0 _{dec})

Index F010 Module list

Index (hex)	Name	Meaning	Data type	Flags	Default
F010:0	Module list		UINT8	RW	0x04 (4 _{dec})
F010:01	SubIndex 001		UINT32	RW	0x00000190 (400 _{dec})
F010:02	SubIndex 002		UINT32	RW	0x00000190 (400 _{dec})
F010:03	SubIndex 003		UINT32	RW	0x00000190 (400 _{dec})
F010:04	SubIndex 004		UINT32	RW	0x00000190 (400 _{dec})

5.4 Restore the delivery state

You can restore the delivery state of the backup objects as follows:

1. Ensure that TwinCAT is running in Config mode.
2. In CoE object 1011:0 "Restore default parameters" select parameter 1011:01 "Subindex 001".

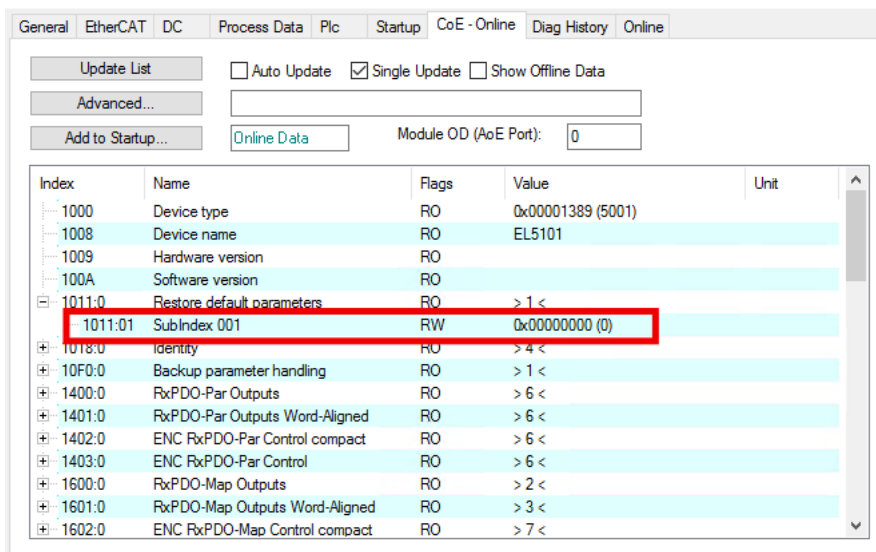

3. Double-click on "Subindex 001".
⇒ The "Set Value Dialog" dialog box opens.
4. Enter the value 1684107116 in the "Dec" field.
Alternatively: enter the value 0x64616F6C in the "Hex" field.

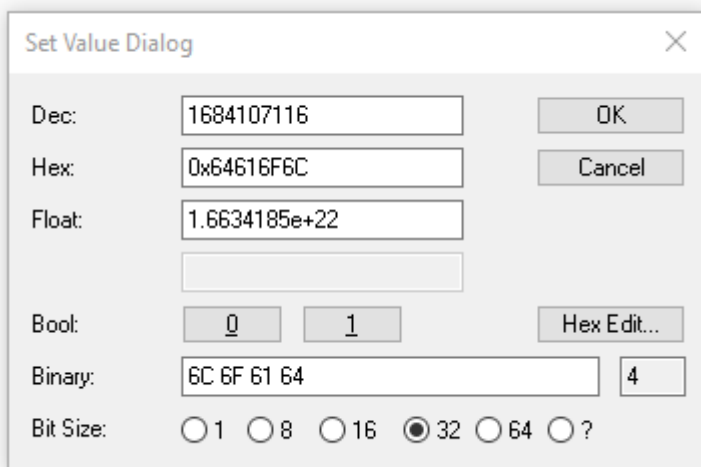

5. Confirm with "OK".
⇒ All backup objects are reset to the delivery state.

i Alternative restore value

With some older modules the backup objects can be changed with an alternative restore value:

Decimal value: 1819238756

Hexadecimal value: 0x6C6F6164

An incorrect entry for the restore value has no effect.

6 Appendix

6.1 General operating conditions

Protection rating according to IP code

The degrees of protection are defined and divided into different classes in the IEC 60529 standard (EN 60529). Degrees of protection are designated by the letters "IP" and two numerals: **IPxy**

- Numeral x: Dust protection and contact protection
- Numeral y: Protection against water

x	Meaning
0	Not protected
1	Protected against access to dangerous parts with the back of the hand. Protected against solid foreign objects of 50 mm Ø
2	Protected against access to dangerous parts with a finger. Protected against solid foreign objects of 12.5 mm Ø
3	Protected against access to dangerous parts with a tool. Protected against solid foreign objects of 2.5 mm Ø
4	Protected against access to dangerous parts with a wire. Protected against solid foreign objects of 1 mm Ø
5	Protection against access to dangerous parts with a wire. Dust-protected. Ingress of dust is not prevented completely, although the quantity of dust able to penetrate is limited to such an extent that the proper function of the device and safety are not impaired
6	Protection against access to dangerous parts with a wire. Dust-tight. No ingress of dust

y	Meaning
0	Not protected
1	Protection against vertically falling water drops
2	Protection against vertically falling water drops when enclosure tilted up to 15°
3	Protection against spraying water. Water sprayed at an angle of up to 60° on either side of the vertical shall have no harmful effects
4	Protection against splashing water. Water splashed against the enclosure from any direction shall have no harmful effects
5	Protection against water jets.
6	Protection against powerful water jets.
7	Protected against the effects of temporary immersion in water. Ingress of water in quantities causing harmful effects shall not be possible when the enclosure is immersed in water at a depth of 1 m for 30 minutes

Chemical resistance

The resistance refers to the housing of the IP67 modules and the metal parts used. In the table below you will find some typical resistances.

Type	Resistance
Water vapor	unstable at temperatures > 100 °C
Sodium hydroxide solution (ph value > 12)	stable at room temperature unstable > 40 °C
Acetic acid	unstable
Argon (technically pure)	stable

Key

- resistant: Lifetime several months
- non inherently resistant: Lifetime several weeks
- not resistant: Lifetime several hours resp. early decomposition

6.2 Accessories

Mounting

Ordering information	Description	Link
ZS5300-0011	Mounting rail	Website

Cables

A complete overview of pre-assembled cables can be found on the Beckhoff website: [Link](#).

Ordering information	Description	Link
ZB8513-0002	EMC shield clamp for M12 connectors	Website
ZK2000-6xxx-xxxx	Sensor cable M12, 4-pin	Website
ZK2000-7xxx-0xxx	Sensor cable M12, 4-pin + shield	Website
ZK700x-xxxx-xxxx	EtherCAT P cable M8	Website

Labeling material, protective caps

Ordering information	Description
ZS5000-0012	Protective cap for M8 sockets, P-coded, IP67 (50 pieces)
ZS5000-0020	Protective cap for M12 sockets, IP67 (50 pcs.)
ZS5100-0000	Inscription labels, unprinted, 4 strips of 10
ZS5000-xxxx	Printed inscription labels on enquiry

Tools

Ordering information	Description
ZB8801-0000	Torque wrench for plugs, 0.4...1.0 Nm
ZB8801-0001	Torque cable key for M8 / wrench size 9 for ZB8801-0000
ZB8801-0002	Torque cable key for M12 / wrench size 13 for ZB8801-0000
ZB8801-0003	Torque cable key for M12 field assembly / wrench size 18 for ZB8801-0000

i Further accessories

Further accessories can be found in the price list for fieldbus components from Beckhoff and online at <https://www.beckhoff.com>.

6.3 Further documentation for I/O components with analog in and outputs

NOTICE



Further documentation for I/O components with analog in and outputs

Also pay attention to the further documentation:

I/O Analog Manual

Notes on I/O components with analog inputs and outputs,

which is available in the Beckhoff [Information-System](#) and for [download](#) on the Beckhoff website www.beckhoff.com on the respective product pages!

The content includes the basics of sensor technology and information on analog measured values.

6.4 Version identification of EtherCAT devices

6.4.1 General notes on marking

Designation

A Beckhoff EtherCAT device has a 14-digit designation, made up of

- family key
- type
- version
- revision

Example	Family	Type	Version	Revision
EL3314-0000-0016	EL terminal 12 mm, non-pluggable connection level	3314 4-channel thermocouple terminal	0000 basic type	0016
ES3602-0010-0017	ES terminal 12 mm, pluggable connection level	3602 2-channel voltage measurement	0010 high-precision version	0017
CU2008-0000-0000	CU device	2008 8-port fast ethernet switch	0000 basic type	0000

Notes

- The elements mentioned above result in the **technical designation**. EL3314-0000-0016 is used in the example below.
- EL3314-0000 is the order identifier, in the case of "-0000" usually abbreviated to EL3314. "-0016" is the EtherCAT revision.
- The **order identifier** is made up of
 - family key (EL, EP, CU, ES, KL, CX, etc.)
 - type (3314)
 - version (-0000)
- The **revision** -0016 shows the technical progress, such as the extension of features with regard to the EtherCAT communication, and is managed by Beckhoff.
In principle, a device with a higher revision can replace a device with a lower revision, unless specified otherwise, e.g. in the documentation.
Associated and synonymous with each revision there is usually a description (ESI, EtherCAT Slave Information) in the form of an XML file, which is available for download from the Beckhoff web site.
From 2014/01 the revision is shown on the outside of the IP20 terminals, see Fig. "EL2872 with revision 0022 and serial number 01200815".
- The type, version and revision are read as decimal numbers, even if they are technically saved in hexadecimal.

6.4.2 Version identification of IP67 modules

The serial number/ data code for Beckhoff IO devices is usually the 8-digit number printed on the device or on a sticker. The serial number indicates the configuration in delivery state and therefore refers to a whole production batch, without distinguishing the individual modules of a batch.

Structure of the serial number: **KK YY FF HH**

KK - week of production (CW, calendar week)
 YY - year of production
 FF - firmware version
 HH - hardware version

Example with serial number 12 06 3A 02:

12 - production week 12
 06 - production year 2006
 3A - firmware version 3A
 02 - hardware version 02

Exceptions can occur in the **IP67 area**, where the following syntax can be used (see respective device documentation):

Syntax: D ww yy x y z u

D - prefix designation
 ww - calendar week
 yy - year
 x - firmware version of the bus PCB
 y - hardware version of the bus PCB
 z - firmware version of the I/O PCB
 u - hardware version of the I/O PCB

Example: D.22081501 calendar week 22 of the year 2008 firmware version of bus PCB: 1 hardware version of bus PCB: 5 firmware version of I/O PCB: 0 (no firmware necessary for this PCB) hardware version of I/O PCB: 1

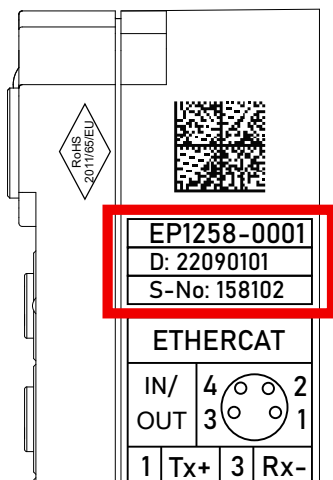

Fig. 6: EP1258-00001 IP67 EtherCAT Box with batch number/DateCode 22090101 and unique serial number 158102

6.4.3 Beckhoff Identification Code (BIC)

The Beckhoff Identification Code (BIC) is increasingly being applied to Beckhoff products to uniquely identify the product. The BIC is represented as a Data Matrix Code (DMC, code scheme ECC200), the content is based on the ANSI standard MH10.8.2-2016.



Fig. 7: BIC as data matrix code (DMC, code scheme ECC200)

The BIC will be introduced step by step across all product groups.

Depending on the product, it can be found in the following places:

- on the packaging unit
- directly on the product (if space suffices)
- on the packaging unit and the product

The BIC is machine-readable and contains information that can also be used by the customer for handling and product management.

Each piece of information can be uniquely identified using the so-called data identifier (ANSI MH10.8.2-2016). The data identifier is followed by a character string. Both together have a maximum length according to the table below. If the information is shorter, spaces are added to it.

Following information is possible, positions 1 to 4 are always present, the other according to need of production:

Position	Type of information	Explanation	Data identifier	Number of digits incl. data identifier	Example
1	Beckhoff order number	Beckhoff order number	1P	8	1P 072222
2	Beckhoff Traceability Number (BTN)	Unique serial number, see note below	SBTN	12	SBTN k4p562d7
3	Article description	Beckhoff article description, e.g. EL1008	1K	32	1K EL1809
4	Quantity	Quantity in packaging unit, e.g. 1, 10, etc.	Q	6	Q1
5	Batch number	Optional: Year and week of production	2P	14	2P 401503180016
6	ID/serial number	Optional: Present-day serial number system, e.g. with safety products	51S	12	51S 678294
7	Variant number	Optional: Product variant number on the basis of standard products	30P	32	30P F971, 2*K183
...					

Further types of information and data identifiers are used by Beckhoff and serve internal processes.

Structure of the BIC

Example of composite information from positions 1 to 4 and with the above given example value on position 6. The data identifiers are highlighted in bold font:

1P072222**SBTN**k4p562d7**1K**EL1809 **Q1** **51S**678294

Accordingly as DMC:



Fig. 8: Example DMC **1P**072222**SBTN**k4p562d7**1K**EL1809 **Q1** **51S**678294

BTN

An important component of the BIC is the Beckhoff Traceability Number (BTN, position 2). The BTN is a unique serial number consisting of eight characters that will replace all other serial number systems at Beckhoff in the long term (e.g. batch designations on IO components, previous serial number range for safety products, etc.). The BTN will also be introduced step by step, so it may happen that the BTN is not yet coded in the BIC.

NOTICE
<p>This information has been carefully prepared. However, the procedure described is constantly being further developed. We reserve the right to revise and change procedures and documentation at any time and without prior notice. No claims for changes can be made from the information, illustrations and descriptions in this documentation.</p>

6.4.4 Electronic access to the BIC (eBIC)

Electronic BIC (eBIC)

The Beckhoff Identification Code (BIC) is applied to the outside of Beckhoff products in a visible place. If possible, it should also be electronically readable.

The interface that the product can be electronically addressed by is crucial for the electronic readout.

EtherCAT devices (IP20, IP67)

All Beckhoff EtherCAT devices have an ESI-EEPROM which contains the EtherCAT identity with the revision number. The EtherCAT slave information, also colloquially known as the ESI/XML configuration file for the EtherCAT master, is stored in it. See the corresponding chapter in the EtherCAT system manual ([Link](#)) for the relationships.

Beckhoff also stores the eBIC in the ESI-EEPROM. The eBIC was introduced into Beckhoff IO production (terminals, box modules) in 2020; as of 2023, implementation is largely complete.

The user can electronically access the eBIC (if present) as follows:

- With all EtherCAT devices, the EtherCAT master (TwinCAT) can read the eBIC from the ESI-EEPROM
 - From TwinCAT 3.1 build 4024.11, the eBIC can be displayed in the online view.
 - To do this, check the "Show Beckhoff Identification Code (BIC)" checkbox under EtherCAT → Advanced Settings → Diagnostics:

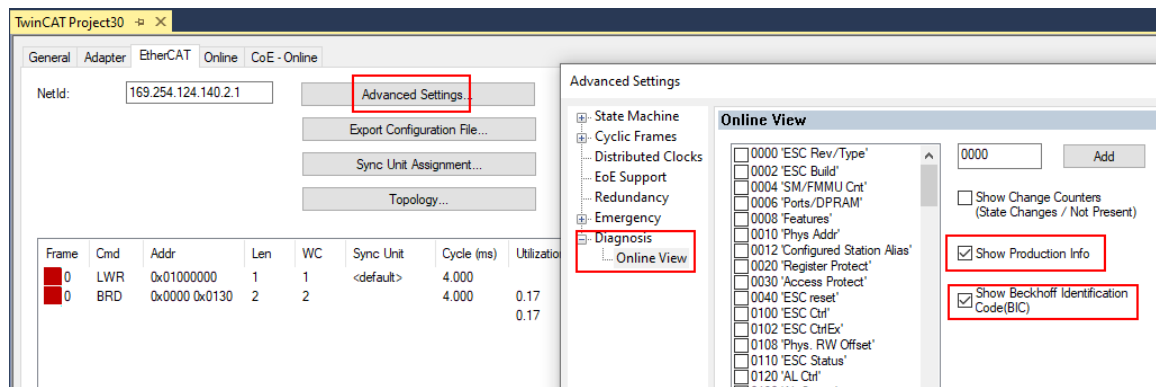

- The BTN and its contents are then displayed:

No	Addr	Name	State	CRC	Fw	Hw	Production Data	ItemNo	BTN	Description	Quantity	BatchNo	SerialNo
1	1001	Term 1 (EK1100)	OP	0,0	0	0	---						
2	1002	Term 2 (EL1018)	OP	0,0	0	0	2020 KW36 Fr	072222	k4p562d7	EL1809	1		678294
3	1003	Term 3 (EL3204)	OP	0,0	7	6	2012 KW24 Sa						
4	1004	Term 4 (EL2004)	OP	0,0	0	0	---	072223	k4p562d7	EL2004	1		678295
5	1005	Term 5 (EL1008)	OP	0,0	0	0	---						
6	1006	Term 6 (EL2008)	OP	0,0	0	12	2014 KW14 Mo						
7	1007	Term 7 (EK1110)	OP	0	1	8	2012 KW25 Mo						

- Note: As shown in the figure, the production data HW version, FW version, and production date, which have been programmed since 2012, can also be displayed with "Show production info".
- Access from the PLC: From TwinCAT 3.1. build 4024.24, the functions *FB_EcReadBIC* and *FB_EcReadBTN* for reading into the PLC are available in the Tc2_EtherCAT library from v3.3.19.0.
- EtherCAT devices with a CoE directory may also have the object 0x10E2:01 to display their own eBIC, which can also be easily accessed by the PLC:

- The device must be in PREOP/SAFEOP/OP for access:

Index	Name	Flags	Value
1000	Device type	RO	0x015E1389 (22942601)
1008	Device name	RO	ELM3704-0000
1009	Hardware version	RO	00
100A	Software version	RO	01
100B	Bootloader version	RO	J0.1.27.0
1011:0	Restore default parameters	RO	> 1 <
1018:0	Identity	RO	> 4 <
10E2:0	Manufacturer-specific Identification C...	RO	> 1 <
10E2:01	Subindex 001	RO	1P158442SBTN0008jckp1KELM3704 Q1 2P482001000016
10F0:0	Backup parameter handling	RO	> 1 <
10F3:0	Diagnosis History	RO	> 21 <
10F8	Actual Time Stamp	RO	0x170bfb277e

- The object 0x10E2 will be preferentially introduced into stock products in the course of necessary firmware revision.
- From TwinCAT 3.1. build 4024.24, the functions *FB_EcCoEReadBIC* and *FB_EcCoEReadBTN* for reading into the PLC are available in the *Tc2_EtherCAT* library from v3.3.19.0
- The following auxiliary functions are available for processing the BIC/BTN data in the PLC in *Tc2_Uilities* as of TwinCAT 3.1 build 4024.24
 - *F_SplitBIC*: The function splits the Beckhoff Identification Code (BIC) *sBICValue* into its components using known identifiers and returns the recognized substrings in the *ST_SplittedBIC* structure as a return value
 - *BIC_TO_BTN*: The function extracts the BTN from the BIC and returns it as a return value
- Note: If there is further electronic processing, the BTN is to be handled as a string(8); the identifier "SBTN" is not part of the BTN.
- Technical background

The new BIC information is written as an additional category in the ESI-EEPROM during device production. The structure of the ESI content is largely dictated by the ETG specifications, therefore the additional vendor-specific content is stored using a category in accordance with the ETG.2010. ID 03 tells all EtherCAT masters that they may not overwrite these data in the event of an update or restore the data after an ESI update.

The structure follows the content of the BIC, see here. The EEPROM therefore requires approx. 50..200 bytes of memory.
- Special cases
 - If multiple hierarchically arranged ESCs are installed in a device, only the top-level ESC carries the eBIC information.
 - If multiple non-hierarchically arranged ESCs are installed in a device, all ESCs carry the eBIC information.
 - If the device consists of several sub-devices which each have their own identity, but only the top-level device is accessible via EtherCAT, the eBIC of the top-level device is located in the CoE object directory 0x10E2:01 and the eBICs of the sub-devices follow in 0x10E2:nn.

6.5 Support and Service

Beckhoff and their partners around the world offer comprehensive support and service, making available fast and competent assistance with all questions related to Beckhoff products and system solutions.

Beckhoff's branch offices and representatives

Please contact your Beckhoff branch office or representative for local support and service on Beckhoff products!

The addresses of Beckhoff's branch offices and representatives round the world can be found on her internet pages: www.beckhoff.com

You will also find further documentation for Beckhoff components there.

Support

The Beckhoff Support offers you comprehensive technical assistance, helping you not only with the application of individual Beckhoff products, but also with other, wide-ranging services:

- support
- design, programming and commissioning of complex automation systems
- and extensive training program for Beckhoff system components

Hotline: +49 5246 963 157
e-mail: support@beckhoff.com
web: www.beckhoff.com/support

Service

The Beckhoff Service Center supports you in all matters of after-sales service:

- on-site service
- repair service
- spare parts service
- hotline service

Hotline: +49 5246 963 460
e-mail: service@beckhoff.com
web: www.beckhoff.com/service

Headquarters Germany

Beckhoff Automation GmbH & Co. KG

Hülshorstweg 20
33415 Verl
Germany

Phone: +49 5246 963 0
e-mail: info@beckhoff.com
web: www.beckhoff.com

More Information:
www.beckhoff.com/epp4174-0002

Beckhoff Automation GmbH & Co. KG
Hülshorstweg 20
33415 Verl
Germany
Phone: +49 5246 9630
info@beckhoff.com
www.beckhoff.com

