

Documentation | EN

EPP1332-0001, EPP1342-0001

EtherCAT P junctions



Table of contents

1	Foreword	5
1.1	Notes on the documentation	5
1.2	Safety instructions	6
1.3	Documentation issue status	7
2	Product group: EtherCAT P Box modules	8
3	Product overview	9
3.1	EPP1332-0001	9
3.1.1	Scope of supply.....	10
3.1.2	EtherCAT data flow	10
3.2	EPP1342-0001	11
3.2.1	Scope of supply.....	12
3.2.2	EtherCAT data flow	12
3.3	Technical data	13
3.4	Process image	15
4	Mounting and cabling	16
4.1	Mounting	16
4.1.1	Dimensions	16
4.1.2	Fixing.....	17
4.1.3	Functional earth (FE)	17
4.1.4	Tightening torques for plug connectors.....	17
4.2	EtherCAT P	18
4.2.1	Connections	19
4.2.2	Status LEDs	20
4.2.3	Conductor losses	21
4.3	Supply voltage feed-in (EPP1332-0001).....	22
4.3.1	Connectors.....	23
4.3.2	Status LEDs	23
4.3.3	Conductor losses	24
4.4	UL Requirements	25
4.5	Disposal	26
5	Commissioning/Configuration	27
5.1	Configuration in TwinCAT	27
5.1.1	Assignment of connectors.....	27
6	Appendix	29
6.1	General operating conditions	29
6.2	Accessories	30
6.3	Version identification of EtherCAT devices	31
6.3.1	General notes on marking.....	31
6.3.2	Version identification of IP67 modules	32
6.3.3	Beckhoff Identification Code (BIC).....	33
6.3.4	Electronic access to the BIC (eBIC).....	35
6.4	Support and Service.....	37

1 Foreword

1.1 Notes on the documentation

Intended audience

This description is only intended for the use of trained specialists in control and automation engineering who are familiar with the applicable national standards.

It is essential that the documentation and the following notes and explanations are followed when installing and commissioning these components.

The qualified personnel is obliged to always use the currently valid documentation.

The responsible staff must ensure that the application or use of the products described satisfy all the requirements for safety, including all the relevant laws, regulations, guidelines and standards.

Disclaimer

The documentation has been prepared with care. The products described are, however, constantly under development.

We reserve the right to revise and change the documentation at any time and without prior announcement.

No claims for the modification of products that have already been supplied may be made on the basis of the data, diagrams and descriptions in this documentation.

Trademarks

Beckhoff®, TwinCAT®, TwinCAT/BSD®, TC/BSD®, EtherCAT®, EtherCAT G®, EtherCAT G10®, EtherCAT P®, Safety over EtherCAT®, TwinSAFE®, XFC®, XTS® and XPlanar® are registered trademarks of and licensed by Beckhoff Automation GmbH. Other designations used in this publication may be trademarks whose use by third parties for their own purposes could violate the rights of the owners.

Patent Pending

The EtherCAT Technology is covered, including but not limited to the following patent applications and patents: EP1590927, EP1789857, EP1456722, EP2137893, DE102015105702 with corresponding applications or registrations in various other countries.



EtherCAT® is registered trademark and patented technology, licensed by Beckhoff Automation GmbH, Germany.

Copyright

© Beckhoff Automation GmbH & Co. KG, Germany.

The reproduction, distribution and utilization of this document as well as the communication of its contents to others without express authorization are prohibited.

Offenders will be held liable for the payment of damages. All rights reserved in the event of the grant of a patent, utility model or design.

1.2 Safety instructions

Safety regulations

Please note the following safety instructions and explanations!
Product-specific safety instructions can be found on following pages or in the areas mounting, wiring, commissioning etc.

Exclusion of liability

All the components are supplied in particular hardware and software configurations appropriate for the application. Modifications to hardware or software configurations other than those described in the documentation are not permitted, and nullify the liability of Beckhoff Automation GmbH & Co. KG.

Personnel qualification

This description is only intended for trained specialists in control, automation and drive engineering who are familiar with the applicable national standards.

Signal words

The signal words used in the documentation are classified below. In order to prevent injury and damage to persons and property, read and follow the safety and warning notices.

Personal injury warnings

⚠ DANGER

Hazard with high risk of death or serious injury.

⚠ WARNING

Hazard with medium risk of death or serious injury.

⚠ CAUTION

There is a low-risk hazard that could result in medium or minor injury.

Warning of damage to property or environment

NOTICE

The environment, equipment, or data may be damaged.

Information on handling the product



This information includes, for example:
recommendations for action, assistance or further information on the product.

1.3 Documentation issue status

Version	Comment
1.4	<ul style="list-style-type: none"> • EtherCAT data flow added
1.3	<ul style="list-style-type: none"> • Dimensions updated • UL requirements updated
1.2	<ul style="list-style-type: none"> • Front page updated • Scope of delivery added • Structure update
1.1	<ul style="list-style-type: none"> • UL and Atex chapters removed • EPP1322-0001 moved to separate documentation • Chapter "Feed-in" added
1.0.9	<ul style="list-style-type: none"> • Preliminary version
1.0.2	<ul style="list-style-type: none"> • EtherCAT P - Calculating cable length, voltage and current added • Cabling updated • Additional checks added
1.0.1	<ul style="list-style-type: none"> • EtherCAT P connection updated
1.0.0	<ul style="list-style-type: none"> • First release
0.5	<ul style="list-style-type: none"> • First preliminary version

Firmware and hardware versions

This documentation refers to the firmware and hardware version that was applicable at the time the documentation was written.

The module features are continuously improved and developed further. Modules having earlier production statuses cannot have the same properties as modules with the latest status. However, existing properties are retained and are not changed, so that older modules can always be replaced with new ones.

The firmware and hardware version (delivery state) can be found in the batch number (D-number) printed on the side of the EtherCAT Box.

Syntax of the batch number (D-number)

D: WW YY FF HH

WW - week of production (calendar week)

YY - year of production

FF - firmware version

HH - hardware version

Example with D no. 29 10 02 01:

29 - week of production 29

10 - year of production 2010

02 - firmware version 02

01 - hardware version 01

Further information on this topic: [Version identification of EtherCAT devices \[► 31\]](#).

2 Product group: EtherCAT P Box modules

EtherCAT P

EtherCAT P supplements the EtherCAT technology with a process in which communication and supply voltages are transmitted on a common line. All EtherCAT properties are retained with this process.

Two supply voltages are transmitted per EtherCAT P line. The supply voltages are electrically isolated from each other and can therefore be switched individually. The nominal supply voltage for both is $24 V_{DC}$.

EtherCAT P uses the same cable structure as EtherCAT: a 4-core Ethernet cable with M8 connectors. The connectors are mechanically coded so that EtherCAT connectors and EtherCAT P connectors cannot be interchanged.

EtherCAT P Box modules

EtherCAT P Box modules are EtherCAT P slaves with degree of protection IP67. They are designed for operation in wet, dirty or dusty industrial environments.

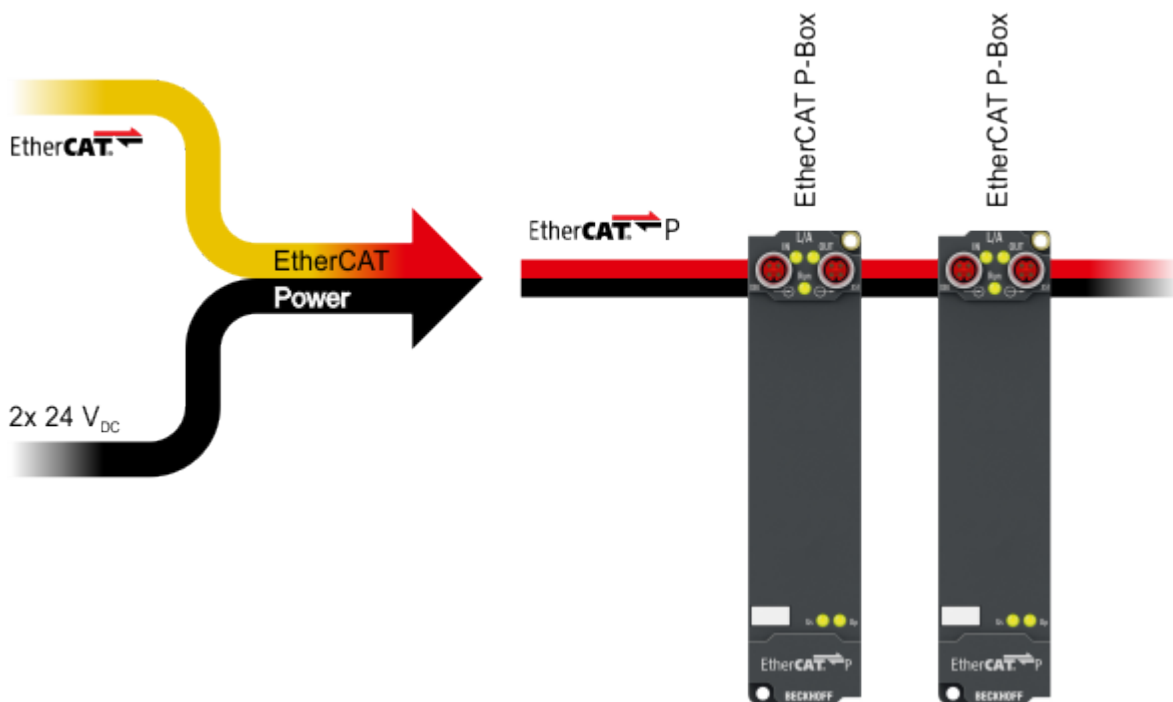

i EtherCAT basics

A detailed description of the EtherCAT system can be found in the [EtherCAT system documentation](#).

3 Product overview

3.1 EPP1332-0001

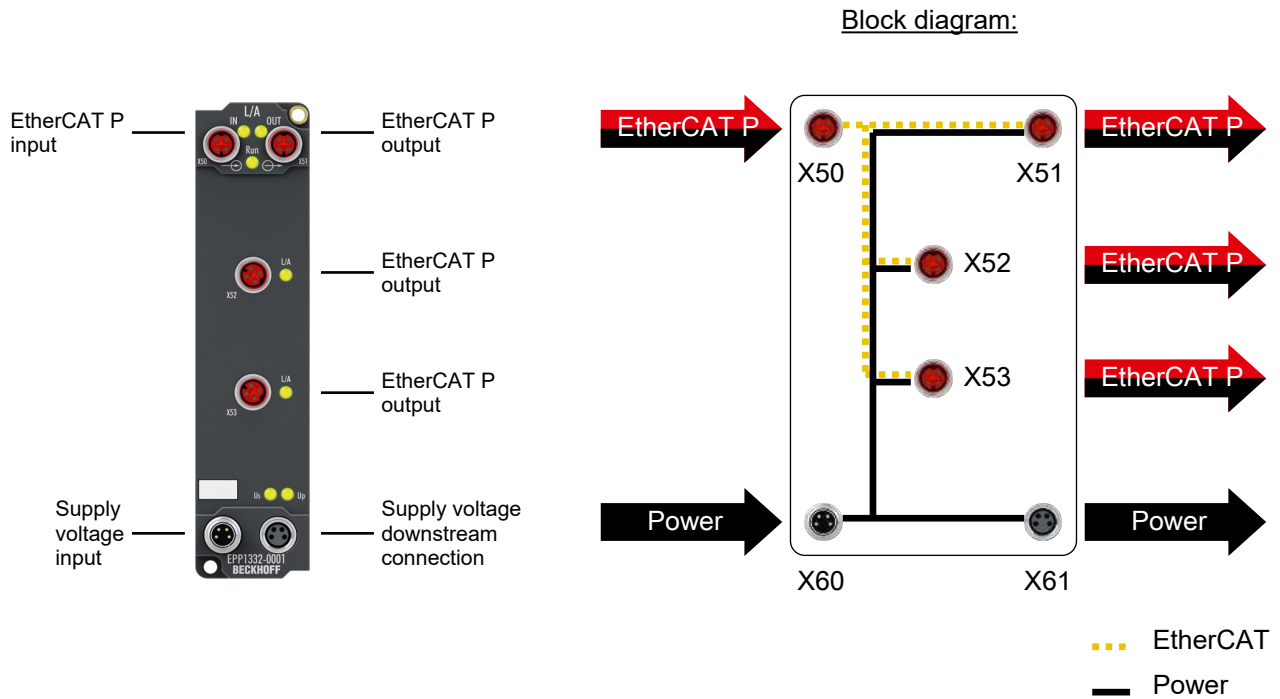

EtherCAT P junction with refresh

The EPP1332-0001 EtherCAT P Box has two functions in an EtherCAT P network:

- Junction: EPP1332-0001 distributes the incoming EtherCAT P signal to three output ports.
- Feed-in point for refreshing the supply voltages.

A refresh of the supply voltages may be necessary in EtherCAT P networks with long cables and/or high output currents. It prevents:

- the supply voltages falling below the permissible minimum due to line losses.
- the current carrying capacity of the EtherCAT P cables being exceeded by high output currents.

A planning tool for EtherCAT P networks integrated in TwinCAT provides support for deciding where in the network a refresh of the supply voltages should be applied.

3.1.1 Scope of supply

Make sure that the following components are included in the scope of delivery:

- 1x EPP1332-0001
- 4x protective cap for EtherCAT P socket, M8, red (pre-assembled)
- 1x protective cap for supply voltage input, M8, transparent (pre-assembled)
- 1x protective cap for supply voltage output, M8, black (pre-assembled)
- 10x labels, blank (1 strip of 10)

● Pre-assembled protective caps do not ensure IP67 protection

i Protective caps are pre-assembled at the factory to protect connectors during transport. They may not be tight enough to ensure IP67 protection.

Ensure that the protective caps are correctly seated to ensure IP67 protection.

3.1.2 EtherCAT data flow

The following figure shows the logical path of an EtherCAT frame through the box.

Ports to which no device is connected are automatically bridged.

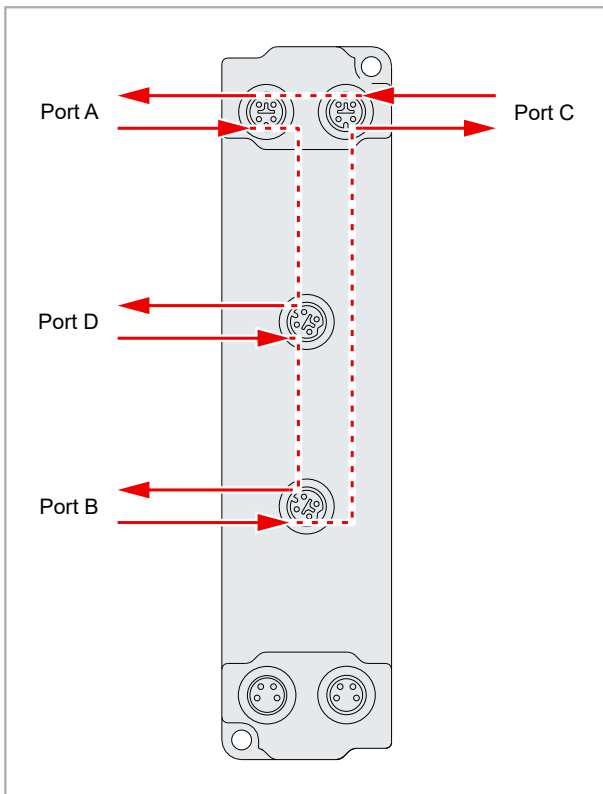

3.2 EPP1342-0001

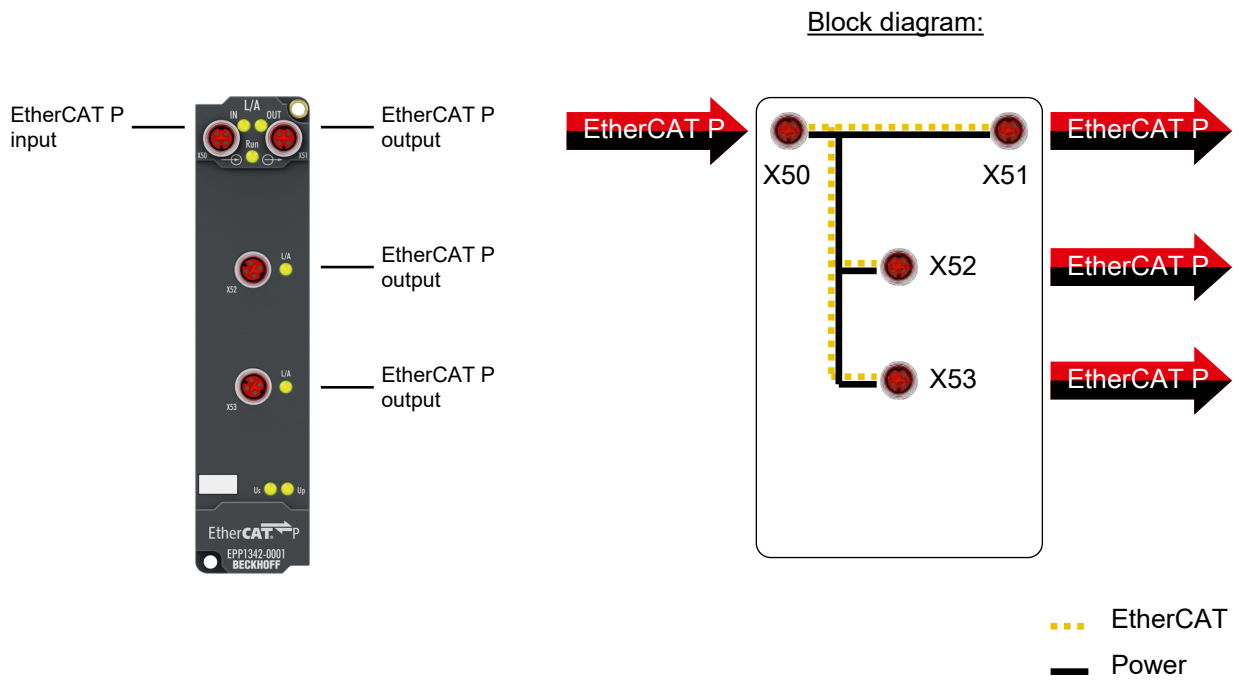

EtherCAT P junction

The EPP1342-0001 EtherCAT P Box distributes the incoming EtherCAT P signal to three output ports.

3.2.1 Scope of supply

Make sure that the following components are included in the scope of delivery:

- 1x EPP1342-0001
- 4x protective cap for EtherCAT P socket, M8, red (pre-assembled)
- 10x labels, blank (1 strip of 10)



Pre-assembled protective caps do not ensure IP67 protection

Protective caps are pre-assembled at the factory to protect connectors during transport. They may not be tight enough to ensure IP67 protection.

Ensure that the protective caps are correctly seated to ensure IP67 protection.

3.2.2 EtherCAT data flow

The following figure shows the logical path of an EtherCAT frame through the box.

Ports to which no device is connected are automatically bridged.

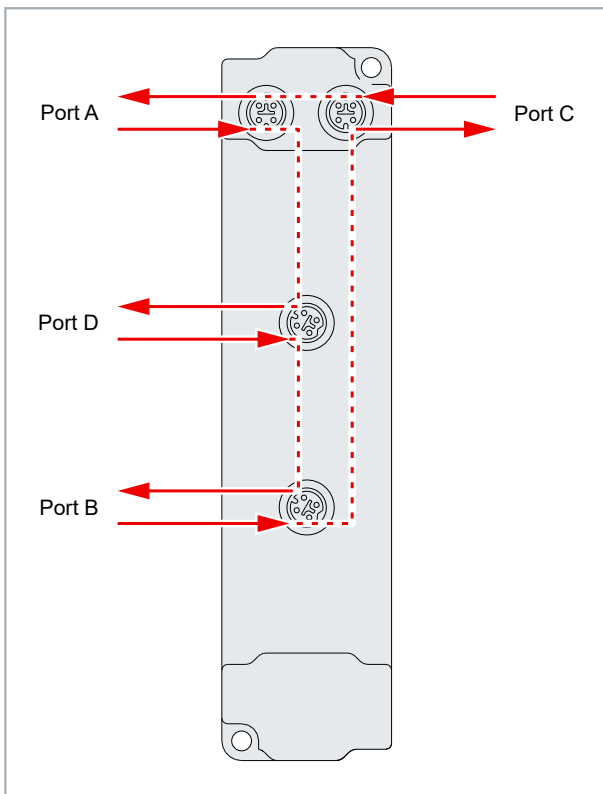

3.3 Technical data

All values are typical values over the entire temperature range, unless stated otherwise.

EtherCAT P input X50	
Connection	1 x M8 socket, 4-pin, P-coded, shielded

EtherCAT P outputs X51, X52, X53	
Number	3
Connection	3 x M8 socket, 4-pin, P-coded, red
Output current	max. 3 A per U_S and U_P for all EtherCAT P outputs in total, short-circuit proof
Cable length	max. 70 m per EtherCAT P segment
Number of EtherCAT P slaves	10 EtherCAT P slaves per segment ¹⁾

¹⁾ This value is a typical value. The number of EtherCAT P slaves actually possible per segment can be affected by:

- the inrush current of sensors/actuators connected to the EtherCAT P slaves
- cable lengths

Supply voltages	EPP1332-0001	EPP1342-0001
Input connection	1 x M8 connector, 4-pin, A-coded	= EtherCAT P input
Downstream connection	1 x M8 socket, 4-pin, A-coded	n/a
U_S nominal voltage	24 V _{DC} (-15 % / +20 %)	
U_S sum current	max. 4 A	max. 3 A
Current consumption from U_S	100 mA + load	
U_P nominal voltage	24 V _{DC} (-15 % / +20 %)	
U_P sum current	max. 4 A	max. 3 A
Current consumption from U_P	= Current consumption of the load from U_P	

Housing data	
Dimensions W x H x D	30 mm x 126 mm x 26.5 mm (without connectors)
Weight	approx. 165 g
Installation position	variable
Material	PA6 (polyamide)

Environmental conditions	
Ambient temperature during operation	-25 ... +60 °C -25 ... +55 °C according to cULus
Ambient temperature during storage	-40 ... +85 °C
Vibration resistance, shock resistance	conforms to EN 60068-2-6 / EN 60068-2-27 Additional tests [► 14]
EMC immunity / emission	conforms to EN 61000-6-2 / EN 61000-6-4
Protection class	IP65, IP66, IP67 (conforms to EN 60529)

Approvals / markings	
Approvals / markings ^{*)}	CE, cULus [► 25]

^{*)} Real applicable approvals/markings see type plate on the side (product marking).

Additional tests

The devices have undergone the following additional tests:

Test	Explanation
Vibration	10 frequency sweeps in 3 axes
	5 Hz < f < 60 Hz displacement 0.35 mm, constant amplitude
	60.1 Hz < f < 500 Hz acceleration 5 g, constant amplitude
Shocks	1000 shocks in each direction, in 3 axes
	35 g, 11 ms

3.4 Process image

The process image of the EPP1332-0001 and EPP1342-0001 modules is identical. The process image of the EPP1332-0001 is shown here as an example.

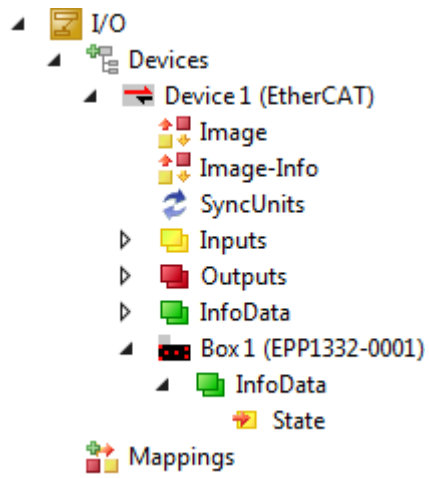

4 Mounting and cabling

4.1 Mounting

4.1.1 Dimensions

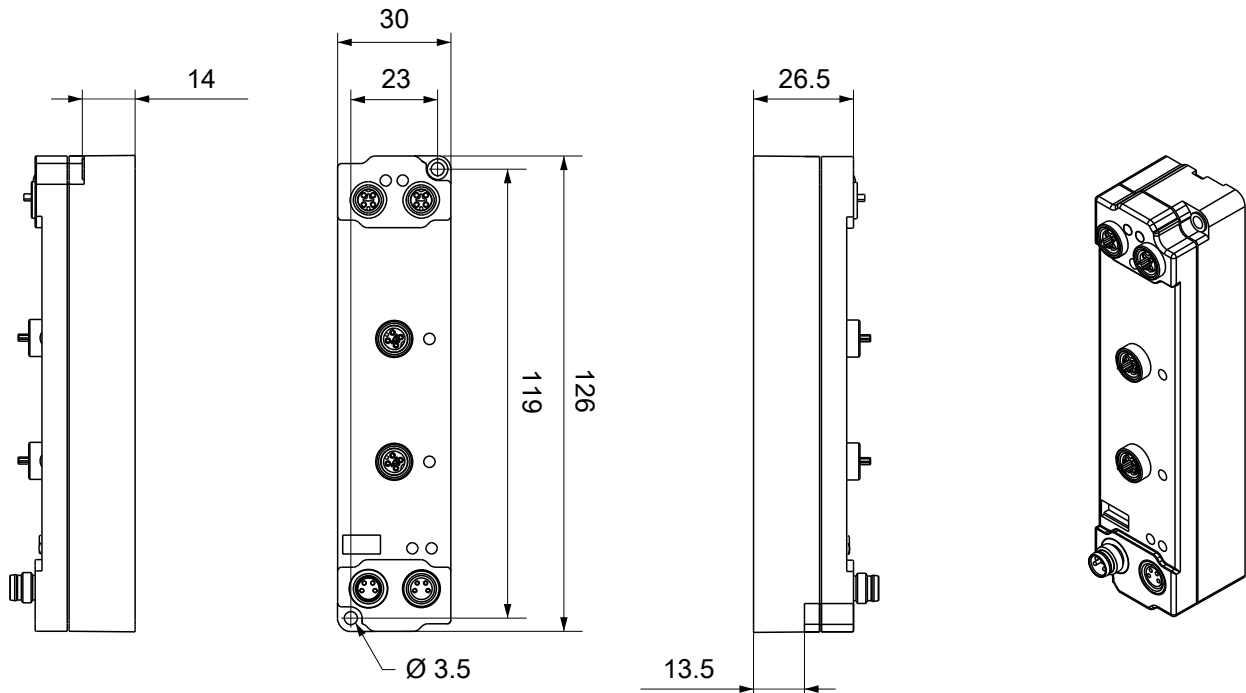

This figure shows the dimensions of the EPP1332-0001 as an example. The dimensions of the EPP1342-0001 are identical.

All dimensions are given in millimeters. The drawing is not true to scale.

Housing features

Housing material	PA6 (polyamide)
Sealing compound	polyurethane
Mounting	two mounting holes \varnothing 3.5 mm for M3
Metal parts	brass, nickel-plated
Contacts	CuZn, gold-plated
Installation position	variable
Protection class	IP65, IP66, IP67 (conforms to EN 60529) when screwed together
Dimensions (H x W x D)	approx. 126 x 30 x 26.5 mm (without connectors)

4.1.2 Fixing

NOTICE

Dirt during assembly

Dirty connectors can lead to malfunctions. Protection class IP67 can only be guaranteed if all cables and connectors are connected.

- Protect the plug connectors against dirt during the assembly.

Mount the module with two M3 screws on the mounting holes in the corners of the module. The mounting holes have no thread.

4.1.3 Functional earth (FE)

The upper mounting holes also serves as a connection for functional earth (FE).

Make sure that the box is grounded to low impedance via the functional earth (FE) connection. You can achieve this, for example, by mounting the box on a grounded machine bed.



Fig. 1: Connection for functional earth (FE)

4.1.4 Tightening torques for plug connectors

Screw M8 connectors tight with a torque wrench. (e.g. ZB8801 from Beckhoff)
Torque: 0.4 Nm.

4.2 EtherCAT P

⚠ WARNING

Power supply from SELV/PELV power supply unit!

SELV/PELV circuits (Safety Extra Low Voltage, Protective Extra Low Voltage) according to IEC 61010-2-201 must be used to supply the EtherCAT P Power Sourcing Device (PSD).

Notes:

- SELV/PELV circuits may give rise to further requirements from standards such as IEC 60204-1 et al, for example with regard to cable spacing and insulation.
- A SELV (Safety Extra Low Voltage) supply provides safe electrical isolation and limitation of the voltage without a connection to the protective conductor, a PELV (Protective Extra Low Voltage) supply also requires a safe connection to the protective conductor.

⚠ CAUTION

Observe the UL requirements

- When operating under UL conditions, observe the warnings in the chapter [UL Requirements](#) [▶ 25].

EtherCAT P transmits two supply voltages:

- **Control voltage U_s**
The following sub-functions are supplied from the control voltage U_s :
 - the fieldbus
 - the processor logic
 - typically the inputs and the sensors if the EtherCAT P Box has inputs.
- **Peripheral voltage U_p**
The digital outputs are typically supplied from the peripheral voltage U_p for EtherCAT P Box modules with digital outputs. U_p can be supplied separately. If U_p is switched off, the fieldbus function, the function of the inputs and the supply of the sensors are maintained.

The exact assignment of U_s and U_p can be found in the pin assignment of the I/O connections.

Forwarding the supply voltages

NOTICE

Limited sum current

The sum of the output currents of the EtherCAT P outputs must not exceed 3 A from U_s and 3 A from U_p .

With the EPP1342-0001, the supply voltages are forwarded internally from the EtherCAT P input X50 to the EtherCAT P outputs X51, X52 and X53.

4.2.1 Connections

NOTICE

Risk of damage to the device!
 Bring the EtherCAT/EtherCAT P system into a safe, powered down state before starting installation, disassembly or wiring of the modules!

The EtherCAT P connections are 4-pin M8 sockets, P-coded.

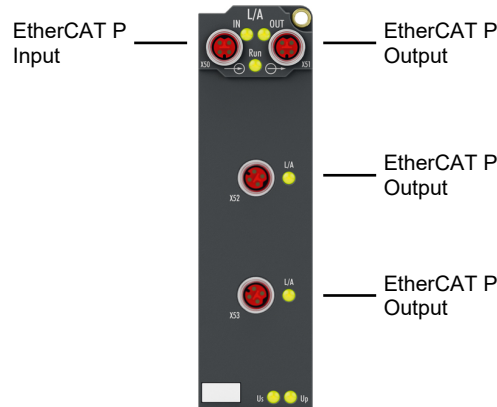

Pin assignment

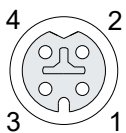

Contact	Signal	Voltage	Core color ¹⁾
1	Tx +	GND _S	yellow
2	Rx +	GND _P	white
3	Rx -	U _P : peripheral voltage, +24 V _{DC}	blue
4	Tx -	U _S : control voltage, +24 V _{DC}	orange
Housing	Shield	Shield	Shield

¹⁾ The core colors apply to EtherCAT P cables and ECP cables from Beckhoff.

The metal threads of the EtherCAT P sockets are internally connected to the FE connection via a high impedance RC combination. See chapter [Functional earth \(FE\)](#) [► 17].

4.2.2 Status LEDs

4.2.2.1 EtherCAT



L/A (Link/Act)

A green LED labeled "L/A" or "Link/Act" is located next to each EtherCAT/EtherCAT P socket. The LED indicates the communication state of the respective socket:

LED	Meaning
off	no connection to the connected EtherCAT device
lit	LINK: connection to the connected EtherCAT device
flashes	ACT: communication with the connected EtherCAT device

Run

Each EtherCAT slave has a green LED labelled "Run". The LED signals the status of the slave in the EtherCAT network:

LED	Meaning
off	Slave is in "Init" state
flashes uniformly	Slave is in "Pre-Operational" state
flashes sporadically	Slave is in "Safe-Operational" state
lit	Slave is in "Operational" state

Description of the EtherCAT slave states

4.2.2.2 Supply voltages

The EPP1342-0001 displays the status of the incoming supply voltages at the EtherCAT P input via two status LEDs:



LED	Display	Meaning
U_s (control voltage)	off	The supply voltage U_s is not available.
	green illuminated	The supply voltage U_s is available.
U_p (peripheral voltage)	off	The supply voltage U_p is not available.
	green illuminated	The supply voltage U_p is available.

4.2.3 Conductor losses

Take into account the voltage drop on the supply line when planning a system. Avoid the voltage drop being so high that the supply voltage at the box lies below the minimum nominal voltage. Variations in the voltage of the power supply unit must also be taken into account.

i Planning tool for EtherCAT P

You can plan cable lengths, voltages and currents of your EtherCAT P system using TwinCAT 3. The requirement for this is TwinCAT 3 Build 4020 or higher.

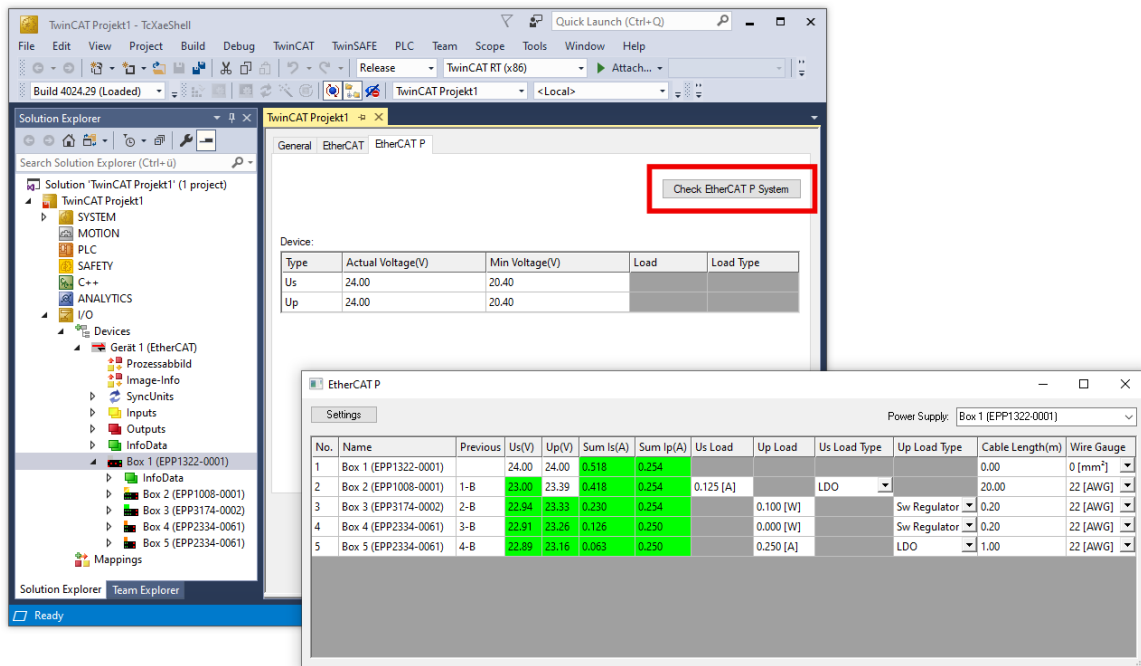

Further information can be found in the quick start guide [IO configuration in TwinCAT](#) in chapter "Configuration of EtherCAT P via TwinCAT".

Voltage drop on the supply line

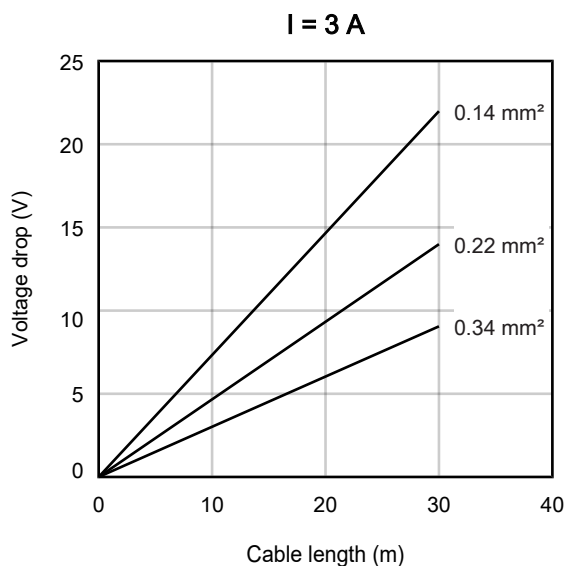

4.3 Supply voltage feed-in (EPP1332-0001)

⚠ WARNING

Power supply from SELV / PELV power supply unit!

SELV / PELV circuits (safety extra-low voltage / protective extra-low voltage) according to IEC 61010-2-201 must be used to supply this device.

Notes:

- SELV / PELV circuits may give rise to further requirements from standards such as IEC 60204-1 et al, for example with regard to cable spacing and insulation.
- A SELV supply provides safe electrical isolation and limitation of the voltage without a connection to the protective conductor, a PELV supply also requires a safe connection to the protective conductor.

⚠ CAUTION

Observe the UL requirements

- When operating under UL conditions, observe the warnings in the chapter [UL Requirements](#) [▶ 25].

The EtherCAT Box has one input for two supply voltages:

- **Control voltage U_s**
The following sub-functions are supplied from the control voltage U_s :
 - the fieldbus
 - the processor logic
 - typically the inputs and the sensors if the EtherCAT Box has inputs.
- **Peripheral voltage U_p**
For EtherCAT Box modules with digital outputs the digital outputs are typically supplied from the peripheral voltage U_p . U_p can be supplied separately. If U_p is switched off, the fieldbus function, the function of the inputs and the supply of the sensors are maintained.

The exact assignment of U_s and U_p can be found in the pin assignment of the I/O connections.

Redirection of the supply voltages

The power IN and OUT connections are bridged in the module. Hence, the supply voltages U_s and U_p can be passed from EtherCAT Box to EtherCAT Box in a simple manner.

NOTICE

Note the maximum current!

Ensure that the permitted current for the connectors is not exceeded when routing the supply voltages U_s and U_p :

M8 connector: max. 4 A
7/8" connector: max 16 A

NOTICE

Unintentional cancellation of the electrical isolation possible

In some types of EtherCAT Box modules the ground potentials GND_s and GND_p are connected.

- If several EtherCAT Box modules are supplied with the same electrically isolated voltages, check whether there is an EtherCAT Box among them in which the ground potentials are connected.

4.3.1 Connectors

NOTICE

Risk of confusion: supply voltages and EtherCAT
 Defect possible through incorrect insertion.

- Observe the color coding of the connectors:
 black: Supply voltages
 green: EtherCAT

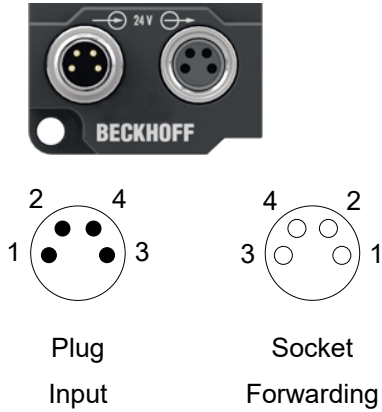

Fig. 2: M8 connector

Contact	Function	Description	Core color ¹⁾
1	U _S	Control voltage	Brown
2	U _P	Peripheral voltage	White
3	GND _S	GND to U _S	Blue
4	GND _P	GND to U _P	Black

¹⁾ The core colors apply to cables of the type: Beckhoff ZK2020-3xxx-xxxx

4.3.2 Status LEDs



LED	Display	Meaning
U _S (control voltage)	off	The supply voltage U _S is not available.
	green illuminated	The supply voltage U _S is available.
U _P (peripheral voltage)	off	The supply voltage U _P is not available.
	green illuminated	The supply voltage U _P is available.

4.3.3 Conductor losses

Take into account the voltage drop on the supply line when planning a system. Avoid the voltage drop being so high that the supply voltage at the box lies below the minimum nominal voltage. Variations in the voltage of the power supply unit must also be taken into account.

Voltage drop on the supply line

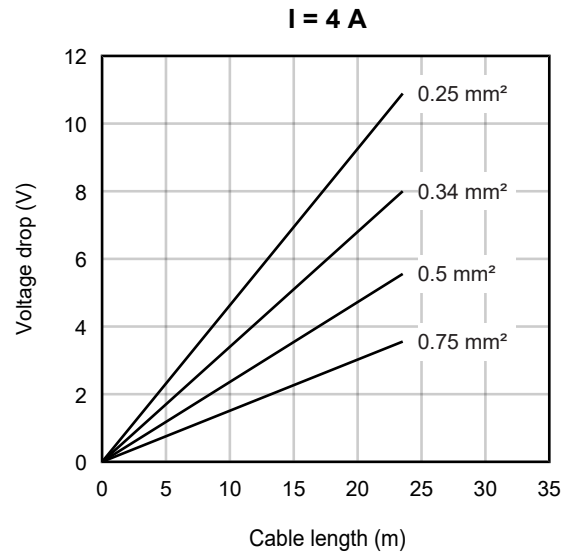
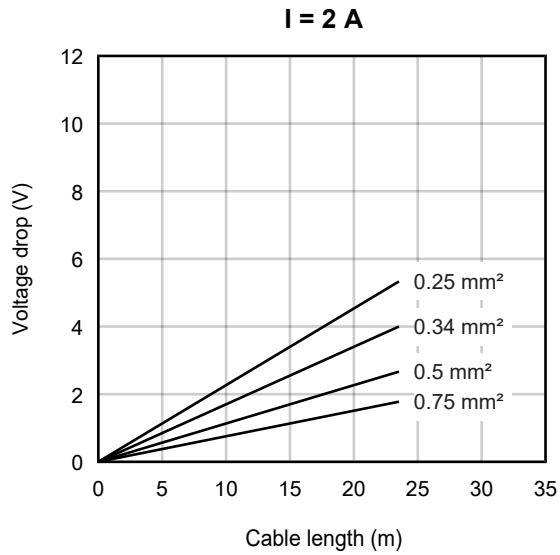

4.4 UL Requirements

The installation of the EtherCAT Box Modules certified by UL has to meet the following requirements.

Supply voltage

⚠ CAUTION

CAUTION!

This UL requirements are valid for all supply voltages of all marked EtherCAT Box Modules!
For the compliance of the UL requirements the EtherCAT Box Modules should only be supplied

- by a 24 V_{DC} supply voltage, supplied by an isolating source and protected by means of a fuse (in accordance with UL248), rated maximum 4 Amp, or
- by a 24 V_{DC} power source, that has to satisfy *NEC class 2*.
A *NEC class 2* power supply shall not be connected in series or parallel with another (class 2) power source!

⚠ CAUTION

CAUTION!

To meet the UL requirements, the EtherCAT Box Modules must not be connected to unlimited power sources!

Networks

⚠ CAUTION

CAUTION!

To meet the UL requirements, EtherCAT Box Modules must not be connected to telecommunication networks!

Ambient temperature range

⚠ CAUTION

CAUTION!

To meet the UL requirements, EtherCAT Box Modules has to be operated only at an ambient temperature range of -25 °C to +55 °C!

Marking for UL

All EtherCAT Box Modules certified by UL (Underwriters Laboratories) are marked with the following label.



Fig. 3: UL label

4.5 Disposal



Products marked with a crossed-out wheeled bin shall not be discarded with the normal waste stream. The device is considered as waste electrical and electronic equipment. The national regulations for the disposal of waste electrical and electronic equipment must be observed.

5 Commissioning/Configuration

5.1 Configuration in TwinCAT

The procedure for integration in a TwinCAT project is described in these [Quick start guide](#).

5.1.1 Assignment of connectors

This chapter describes the assignment of the connectors of EPP1332-0001 and EPP1342-0001 to their representation in TwinCAT. This assignment is required to correctly map an EtherCAT network in TwinCAT "offline" configuration.

An IO module that represents a Box in TwinCAT has four ports: A, B, C, D. Each port represents one connector. The following diagram shows the assignment of the connectors to the ports of an IO module in TwinCAT:

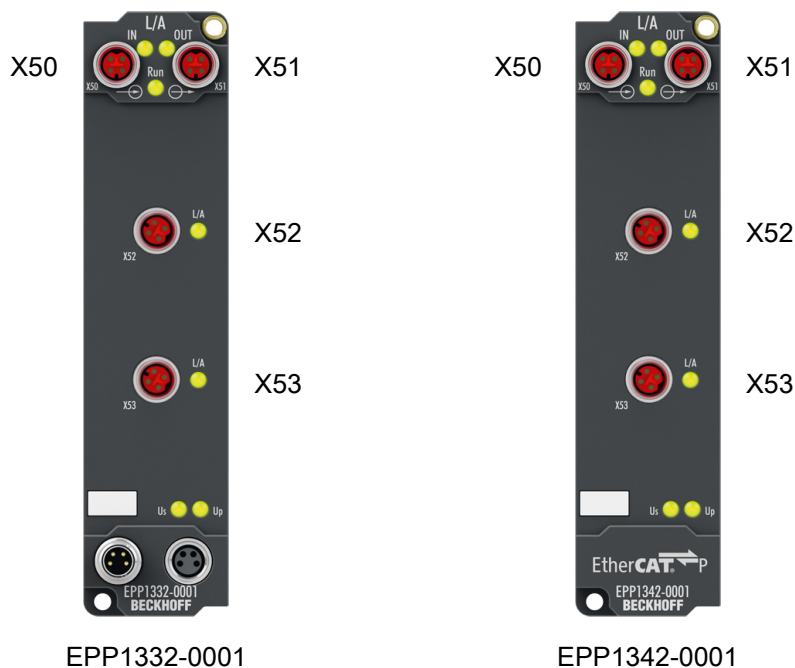

Type	Connector	Port in TwinCAT
EtherCAT P input	X50	A
EtherCAT P output	X51	C
EtherCAT P output	X52	D
EtherCAT P output	X53	B

The following page contains examples of how to use the table.

Example: Attaching an EtherCAT P Box to a junction

- ✓ Requirement: an EtherCAT P junction is added to the IO tree in TwinCAT.
- 1. Decide to which connector the EtherCAT P Box is to be connected.
(e.g. at X52)
- 2. Use the table to determine the corresponding port.
(e.g. Port D)
- 3. Right-click on the EtherCAT P junction in the IO tree.
- 4. Click the menu item **Add new Item...**
- 5. In the window that appears select the EtherCAT P Box to be added and the previously determined port.
(e.g. EPP1008-0001, Port D)

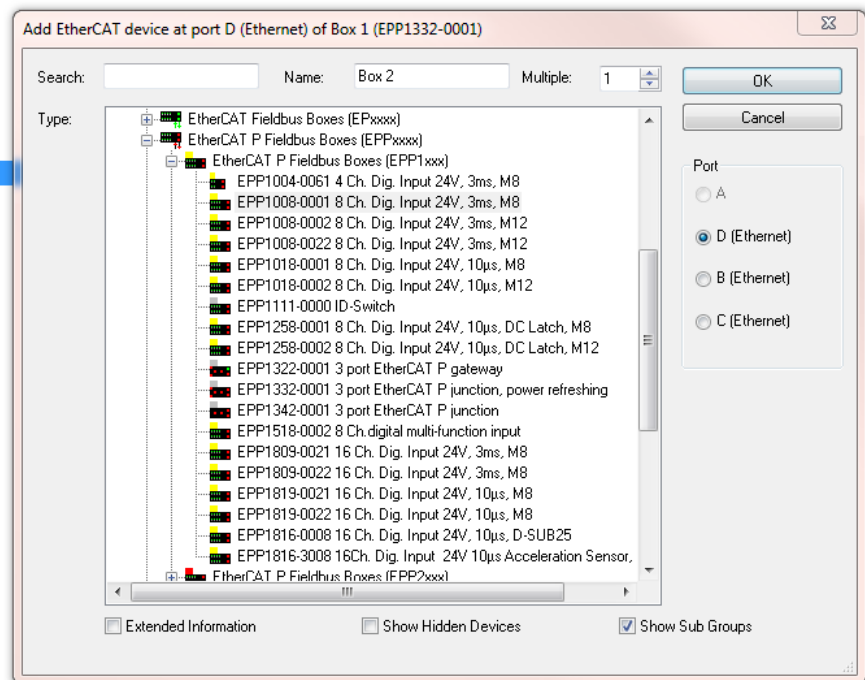
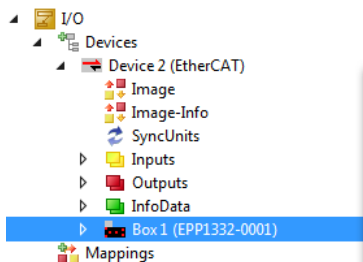

- 6. Click **OK**
- ⇒ Result: The Box was added at the correct position in the IO tree.

Example: Moving a previously added EtherCAT P Box to another connector

- 1. Double-click the EtherCAT P Box in the IO tree.
(e.g. an EPP1008-0001 that was previously connected to X52)
- 2. Click the **EtherCAT** tab.
- 3. Use the table to determine the port of the new connector.
(e.g. X51 → Port C)
- 4. In the **Previous Port** dropdown list box, select the junction IO module and the previously determined port.
(e.g. "Box 1 (EPP1332-0001) - C")
- ⇒ Result: The EtherCAT P Box is connected to the new connector.

Checking the IO configuration graphically

- 1. Double-click the EtherCAT master device in the IO tree.
- 2. Click the **EtherCAT** tab.
- 3. Click the **Topology** button.
- ⇒ Result: A graphical illustration of the network structure created in TwinCAT appears.
Move the mouse pointer over the icons of the IO modules to display their description.

6 Appendix

6.1 General operating conditions

Protection rating according to IP code

The degrees of protection are defined and divided into different classes in the IEC 60529 standard (EN 60529). Degrees of protection are designated by the letters "IP" and two numerals: **IPxy**

- Numeral x: Dust protection and contact protection
- Numeral y: Protection against water

x	Meaning
0	Not protected
1	Protected against access to dangerous parts with the back of the hand. Protected against solid foreign objects of 50 mm Ø
2	Protected against access to dangerous parts with a finger. Protected against solid foreign objects of 12.5 mm Ø
3	Protected against access to dangerous parts with a tool. Protected against solid foreign objects of 2.5 mm Ø
4	Protected against access to dangerous parts with a wire. Protected against solid foreign objects of 1 mm Ø
5	Protection against access to dangerous parts with a wire. Dust-protected. Ingress of dust is not prevented completely, although the quantity of dust able to penetrate is limited to such an extent that the proper function of the device and safety are not impaired
6	Protection against access to dangerous parts with a wire. Dust-tight. No ingress of dust

y	Meaning
0	Not protected
1	Protection against vertically falling water drops
2	Protection against vertically falling water drops when enclosure tilted up to 15°
3	Protection against spraying water. Water sprayed at an angle of up to 60° on either side of the vertical shall have no harmful effects
4	Protection against splashing water. Water splashed against the enclosure from any direction shall have no harmful effects
5	Protection against water jets.
6	Protection against powerful water jets.
7	Protected against the effects of temporary immersion in water. Ingress of water in quantities causing harmful effects shall not be possible when the enclosure is immersed in water at a depth of 1 m for 30 minutes

Chemical resistance

The resistance refers to the housing of the IP67 modules and the metal parts used. In the table below you will find some typical resistances.

Type	Resistance
Water vapor	unstable at temperatures > 100 °C
Sodium hydroxide solution (ph value > 12)	stable at room temperature unstable > 40 °C
Acetic acid	unstable
Argon (technically pure)	stable

Key

- resistant: Lifetime several months
- non inherently resistant: Lifetime several weeks
- not resistant: Lifetime several hours resp. early decomposition

6.2 Accessories

Mounting

Ordering information	Description	Link
ZS5300-0011	Mounting rail	Website

Labeling material, protective caps

Ordering information	Description
ZS5000-0012	Protective cap for M8 sockets, P-coded, IP67 (50 pieces)
ZS5100-0000	Inscription labels, unprinted, 4 strips of 10
ZS5000-xxxx	Printed inscription labels on enquiry

Cables

A complete overview of pre-assembled cables for fieldbus components can be found [here](#).

Ordering information	Description	Link
ZK2020-3xxx-xxxx	Power cable M8, 4-pin	Website
ZK700x-xxxx-xxxx	EtherCAT P cable M8	Website

Tools

Ordering information	Description
ZB8801-0000	Torque wrench for plugs, 0.4...1.0 Nm
ZB8801-0001	Torque cable key for M8 / wrench size 9 for ZB8801-0000



Further accessories

Further accessories can be found in the price list for fieldbus components from Beckhoff and online at <https://www.beckhoff.com>.

6.3 Version identification of EtherCAT devices

6.3.1 General notes on marking

Designation

A Beckhoff EtherCAT device has a 14-digit designation, made up of

- family key
- type
- version
- revision

Example	Family	Type	Version	Revision
EL3314-0000-0016	EL terminal 12 mm, non-pluggable connection level	3314 4-channel thermocouple terminal	0000 basic type	0016
ES3602-0010-0017	ES terminal 12 mm, pluggable connection level	3602 2-channel voltage measurement	0010 high-precision version	0017
CU2008-0000-0000	CU device	2008 8-port fast ethernet switch	0000 basic type	0000

Notes

- The elements mentioned above result in the **technical designation**. EL3314-0000-0016 is used in the example below.
- EL3314-0000 is the order identifier, in the case of “-0000” usually abbreviated to EL3314. “-0016” is the EtherCAT revision.
- The **order identifier** is made up of
 - family key (EL, EP, CU, ES, KL, CX, etc.)
 - type (3314)
 - version (-0000)
- The **revision** -0016 shows the technical progress, such as the extension of features with regard to the EtherCAT communication, and is managed by Beckhoff.
 In principle, a device with a higher revision can replace a device with a lower revision, unless specified otherwise, e.g. in the documentation.
 Associated and synonymous with each revision there is usually a description (ESI, EtherCAT Slave Information) in the form of an XML file, which is available for download from the Beckhoff web site.
 From 2014/01 the revision is shown on the outside of the IP20 terminals, see Fig. “EL2872 with revision 0022 and serial number 01200815”.
- The type, version and revision are read as decimal numbers, even if they are technically saved in hexadecimal.

6.3.2 Version identification of IP67 modules

The serial number/ data code for Beckhoff IO devices is usually the 8-digit number printed on the device or on a sticker. The serial number indicates the configuration in delivery state and therefore refers to a whole production batch, without distinguishing the individual modules of a batch.

Structure of the serial number: **KK YY FF HH**

KK - week of production (CW, calendar week)

YY - year of production

FF - firmware version

HH - hardware version

Example with serial number 12 06 3A 02:

12 - production week 12

06 - production year 2006

3A - firmware version 3A

02 - hardware version 02

Exceptions can occur in the **IP67 area**, where the following syntax can be used (see respective device documentation):

Syntax: D ww yy x y z u

D - prefix designation

ww - calendar week

yy - year

x - firmware version of the bus PCB

y - hardware version of the bus PCB

z - firmware version of the I/O PCB

u - hardware version of the I/O PCB

Example: D.22081501 calendar week 22 of the year 2008 firmware version of bus PCB: 1 hardware version of bus PCB: 5 firmware version of I/O PCB: 0 (no firmware necessary for this PCB) hardware version of I/O PCB: 1

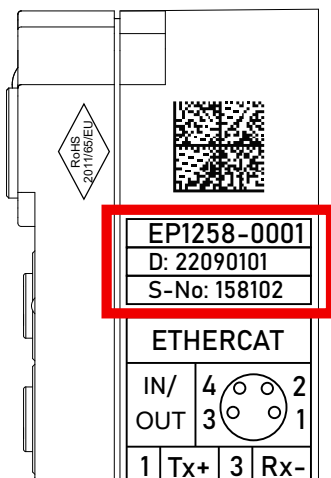

Fig. 4: EP1258-00001 IP67 EtherCAT Box with batch number/DateCode 22090101 and unique serial number 158102

6.3.3 Beckhoff Identification Code (BIC)

The Beckhoff Identification Code (BIC) is increasingly being applied to Beckhoff products to uniquely identify the product. The BIC is represented as a Data Matrix Code (DMC, code scheme ECC200), the content is based on the ANSI standard MH10.8.2-2016.

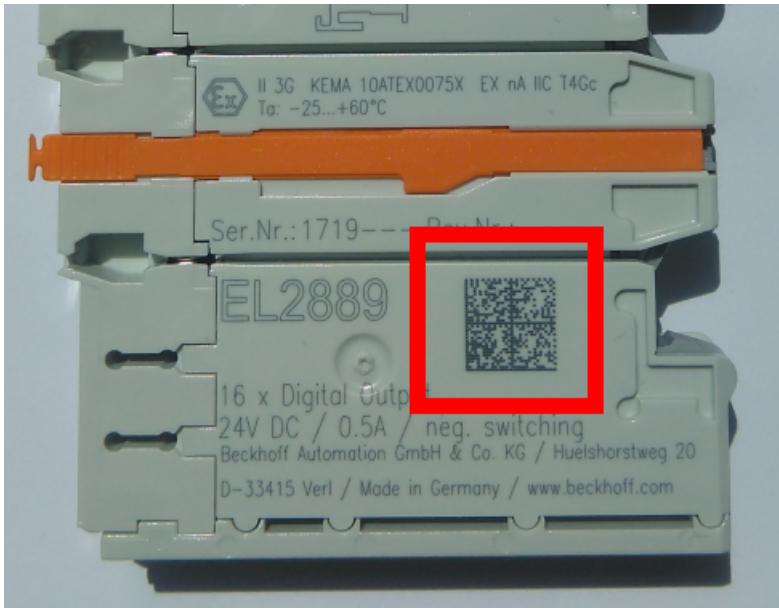

Fig. 5: BIC as data matrix code (DMC, code scheme ECC200)

The BIC will be introduced step by step across all product groups.

Depending on the product, it can be found in the following places:

- on the packaging unit
- directly on the product (if space suffices)
- on the packaging unit and the product

The BIC is machine-readable and contains information that can also be used by the customer for handling and product management.

Each piece of information can be uniquely identified using the so-called data identifier (ANSI MH10.8.2-2016). The data identifier is followed by a character string. Both together have a maximum length according to the table below. If the information is shorter, spaces are added to it.

Following information is possible, positions 1 to 4 are always present, the other according to need of production:

Position	Type of information	Explanation	Data identifier	Number of digits incl. data identifier	Example
1	Beckhoff order number	Beckhoff order number	1P	8	1P 072222
2	Beckhoff Traceability Number (BTN)	Unique serial number, see note below	SBTN	12	SBTN k4p562d7
3	Article description	Beckhoff article description, e.g. EL1008	1K	32	1K EL1809
4	Quantity	Quantity in packaging unit, e.g. 1, 10, etc.	Q	6	Q1
5	Batch number	Optional: Year and week of production	2P	14	2P 401503180016
6	ID/serial number	Optional: Present-day serial number system, e.g. with safety products	51S	12	51S 678294
7	Variant number	Optional: Product variant number on the basis of standard products	30P	32	30P F971, 2*K183
...					

Further types of information and data identifiers are used by Beckhoff and serve internal processes.

Structure of the BIC

Example of composite information from positions 1 to 4 and with the above given example value on position 6. The data identifiers are highlighted in bold font:

1P072222**SBTN**k4p562d7**1K**EL1809 **Q1** **51S**678294

Accordingly as DMC:



Fig. 6: Example DMC **1P**072222**SBTN**k4p562d7**1K**EL1809 **Q1** **51S**678294

BTN

An important component of the BIC is the Beckhoff Traceability Number (BTN, position 2). The BTN is a unique serial number consisting of eight characters that will replace all other serial number systems at Beckhoff in the long term (e.g. batch designations on IO components, previous serial number range for safety products, etc.). The BTN will also be introduced step by step, so it may happen that the BTN is not yet coded in the BIC.

NOTICE

This information has been carefully prepared. However, the procedure described is constantly being further developed. We reserve the right to revise and change procedures and documentation at any time and without prior notice. No claims for changes can be made from the information, illustrations and descriptions in this documentation.

6.3.4 Electronic access to the BIC (eBIC)

Electronic BIC (eBIC)

The Beckhoff Identification Code (BIC) is applied to the outside of Beckhoff products in a visible place. If possible, it should also be electronically readable.

The interface that the product can be electronically addressed by is crucial for the electronic readout.

EtherCAT devices (IP20, IP67)

All Beckhoff EtherCAT devices have an ESI-EEPROM which contains the EtherCAT identity with the revision number. The EtherCAT slave information, also colloquially known as the ESI/XML configuration file for the EtherCAT master, is stored in it. See the corresponding chapter in the EtherCAT system manual ([Link](#)) for the relationships.

Beckhoff also stores the eBIC in the ESI-EEPROM. The eBIC was introduced into Beckhoff IO production (terminals, box modules) in 2020; as of 2023, implementation is largely complete.

The user can electronically access the eBIC (if present) as follows:

- With all EtherCAT devices, the EtherCAT master (TwinCAT) can read the eBIC from the ESI-EEPROM
 - From TwinCAT 3.1 build 4024.11, the eBIC can be displayed in the online view.
 - To do this, check the "Show Beckhoff Identification Code (BIC)" checkbox under EtherCAT → Advanced Settings → Diagnostics:

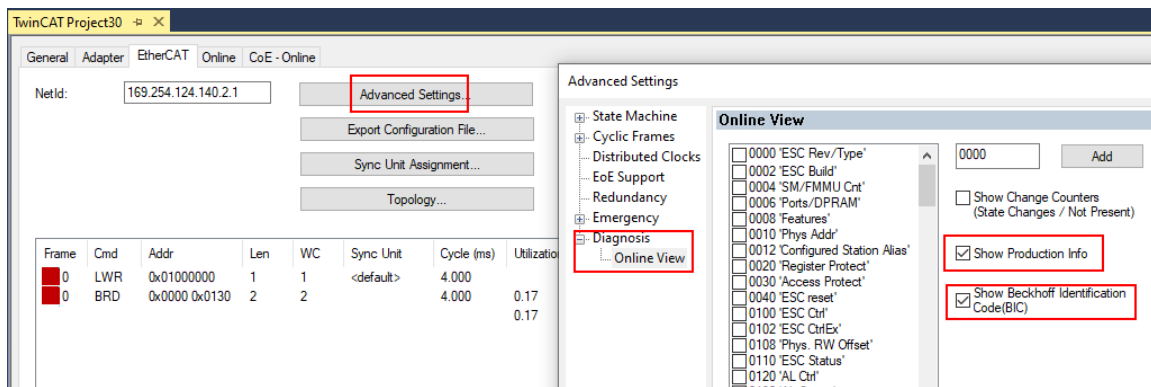

- The BTN and its contents are then displayed:

No	Addr	Name	State	CRC	Fw	Hw	Production Data	ItemNo	BTN	Description	Quantity	BatchNo	SerialNo
1	1001	Term 1 (EK1100)	OP	0,0	0	0	---						
2	1002	Term 2 (EL1018)	OP	0,0	0	0	2020 KW36 Fr	072222	k4p562d7	EL1809	1		678294
3	1003	Term 3 (EL3204)	OP	0,0	7	6	2012 KW24 Sa						
4	1004	Term 4 (EL2004)	OP	0,0	0	0	---	072223	k4p562d7	EL2004	1		678295
5	1005	Term 5 (EL1008)	OP	0,0	0	0	---						
6	1006	Term 6 (EL2008)	OP	0,0	0	12	2014 KW14 Mo						
7	1007	Term 7 (EK1110)	OP	0	1	8	2012 KW25 Mo						

- Note: As shown in the figure, the production data HW version, FW version, and production date, which have been programmed since 2012, can also be displayed with "Show production info".
- Access from the PLC: From TwinCAT 3.1. build 4024.24, the functions *FB_EcReadBIC* and *FB_EcReadBTN* for reading into the PLC are available in the Tc2_EtherCAT library from v3.3.19.0.
- EtherCAT devices with a CoE directory may also have the object 0x10E2:01 to display their own eBIC, which can also be easily accessed by the PLC:

- The device must be in PREOP/SAFEOP/OP for access:

Index	Name	Flags	Value
1000	Device type	RO	0x015E1389 (22942601)
1008	Device name	RO	ELM3704-0000
1009	Hardware version	RO	00
100A	Software version	RO	01
100B	Bootloader version	RO	J0.1.27.0
1011:0	Restore default parameters	RO	> 1 <
1018:0	Identity	RO	> 4 <
10E2:0	Manufacturer-specific Identification C...	RO	> 1 <
10E2:01	SubIndex 001	RO	1P158442SBTN0008jckp1KELM3704 Q1 2P482001000016
10F0:0	Backup parameter handling	RO	> 1 <
10F3:0	Diagnosis History	RO	> 21 <
10F8	Actual Time Stamp	RO	0x170bfb277e

- The object 0x10E2 will be preferentially introduced into stock products in the course of necessary firmware revision.
- From TwinCAT 3.1. build 4024.24, the functions *FB_EcCoEReadBIC* and *FB_EcCoEReadBTN* for reading into the PLC are available in the *Tc2_EtherCAT* library from v3.3.19.0
- The following auxiliary functions are available for processing the BIC/BTN data in the PLC in *Tc2_Uilities* as of TwinCAT 3.1 build 4024.24
 - *F_SplitBIC*: The function splits the Beckhoff Identification Code (BIC) *sBICValue* into its components using known identifiers and returns the recognized substrings in the *ST_SplittedBIC* structure as a return value
 - *BIC_TO_BTN*: The function extracts the BTN from the BIC and returns it as a return value
- Note: If there is further electronic processing, the BTN is to be handled as a string(8); the identifier "SBTN" is not part of the BTN.
- Technical background
The new BIC information is written as an additional category in the ESI-EEPROM during device production. The structure of the ESI content is largely dictated by the ETG specifications, therefore the additional vendor-specific content is stored using a category in accordance with the ETG.2010. ID 03 tells all EtherCAT masters that they may not overwrite these data in the event of an update or restore the data after an ESI update.
The structure follows the content of the BIC, see here. The EEPROM therefore requires approx. 50..200 bytes of memory.
- Special cases
 - If multiple hierarchically arranged ESCs are installed in a device, only the top-level ESC carries the eBIC information.
 - If multiple non-hierarchically arranged ESCs are installed in a device, all ESCs carry the eBIC information.
 - If the device consists of several sub-devices which each have their own identity, but only the top-level device is accessible via EtherCAT, the eBIC of the top-level device is located in the CoE object directory 0x10E2:01 and the eBICs of the sub-devices follow in 0x10E2:nn.

6.4 Support and Service

Beckhoff and their partners around the world offer comprehensive support and service, making available fast and competent assistance with all questions related to Beckhoff products and system solutions.

Beckhoff's branch offices and representatives

Please contact your Beckhoff branch office or representative for local support and service on Beckhoff products!

The addresses of Beckhoff's branch offices and representatives round the world can be found on her internet pages: www.beckhoff.com

You will also find further documentation for Beckhoff components there.

Support

The Beckhoff Support offers you comprehensive technical assistance, helping you not only with the application of individual Beckhoff products, but also with other, wide-ranging services:

- support
- design, programming and commissioning of complex automation systems
- and extensive training program for Beckhoff system components

Hotline: +49 5246 963 157
e-mail: support@beckhoff.com
web: www.beckhoff.com/support

Service

The Beckhoff Service Center supports you in all matters of after-sales service:

- on-site service
- repair service
- spare parts service
- hotline service

Hotline: +49 5246 963 460
e-mail: service@beckhoff.com
web: www.beckhoff.com/service

Headquarters Germany

Beckhoff Automation GmbH & Co. KG

Hülshorstweg 20
33415 Verl
Germany

Phone: +49 5246 963 0
e-mail: info@beckhoff.com
web: www.beckhoff.com

Beckhoff Automation GmbH & Co. KG
Hülshorstweg 20
33415 Verl
Germany
Phone: +49 5246 9630
info@beckhoff.com
www.beckhoff.com