

BG1569 | Empty housing for bus terminals and EtherCAT terminals 600 mm x 250 mm x 120 mm (WxHxL) with inspection window with DIN rail, flange plate with bore holes

Information: On request, the housings are completely equipped with bus terminals or EtherCAT terminals, modified flange plate and PG screw connections deliverable. Other sizes on request.

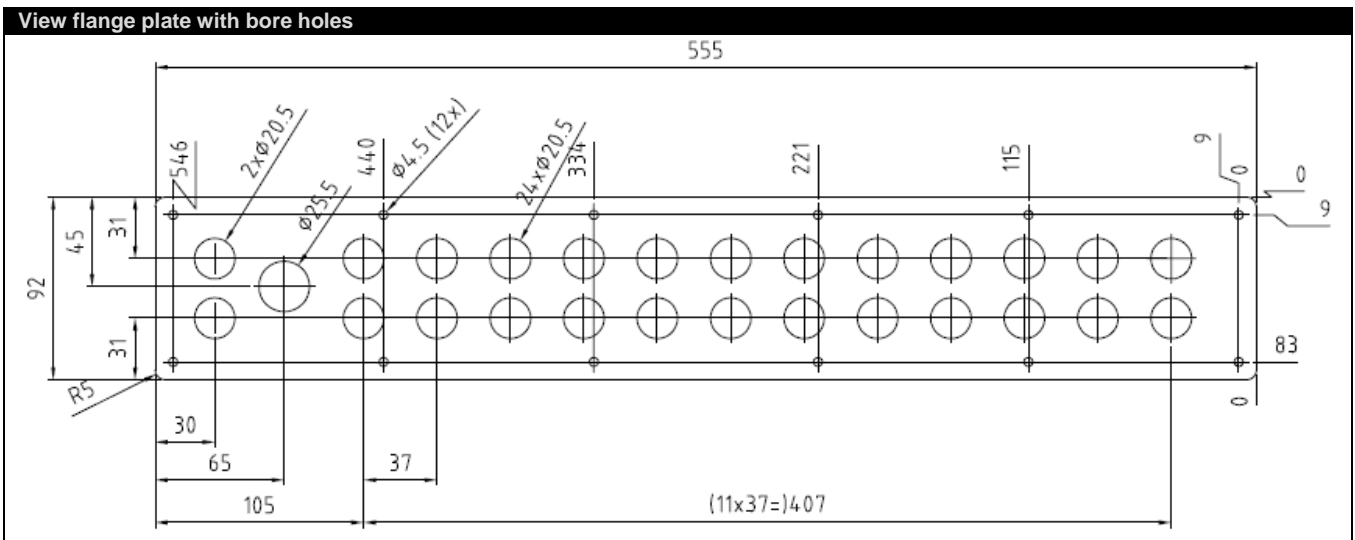

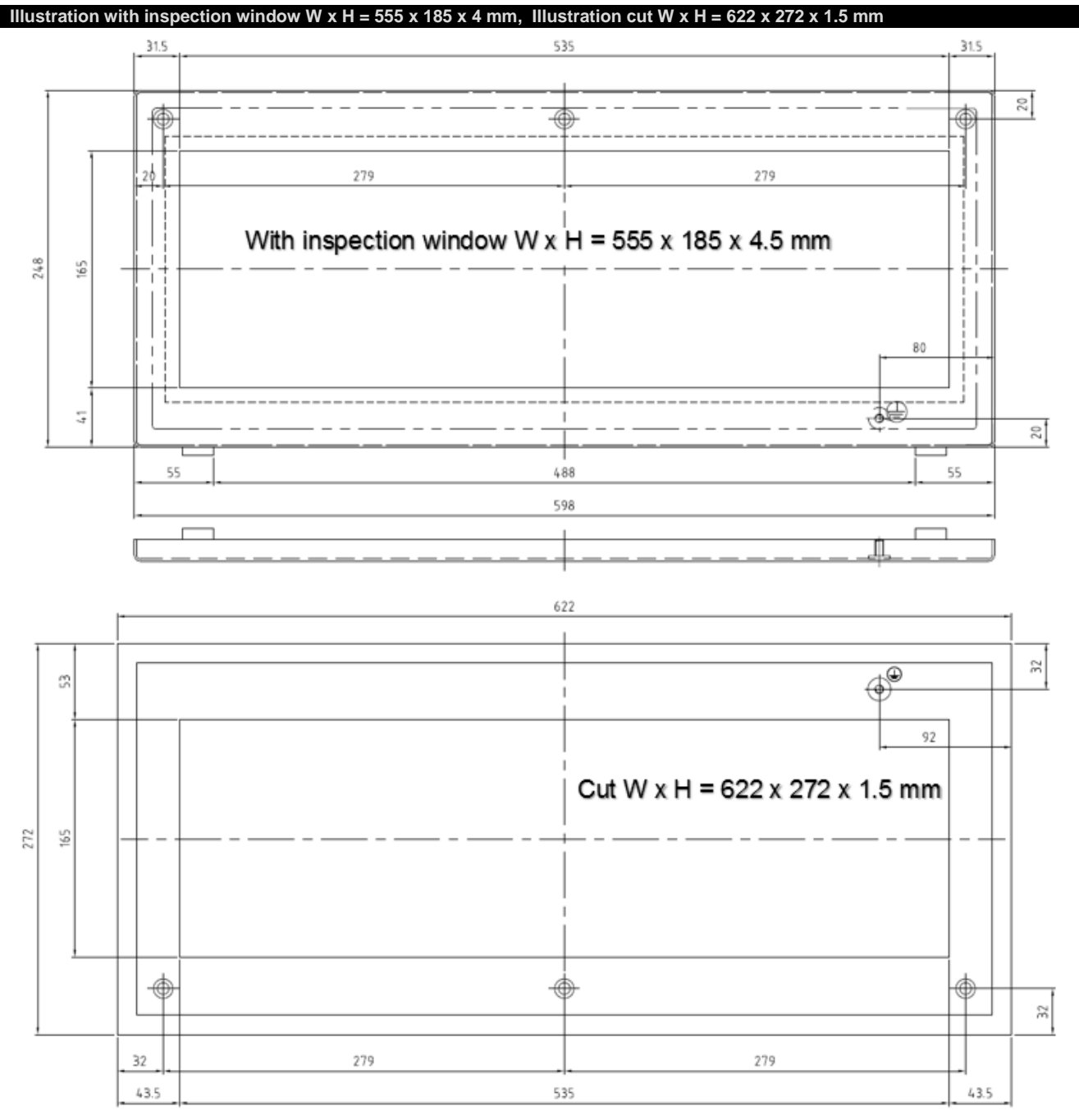

With 3 x fixing angle at top, earthing bolt and enclosed support rail SZ35 / 15 x 587 mm lg.

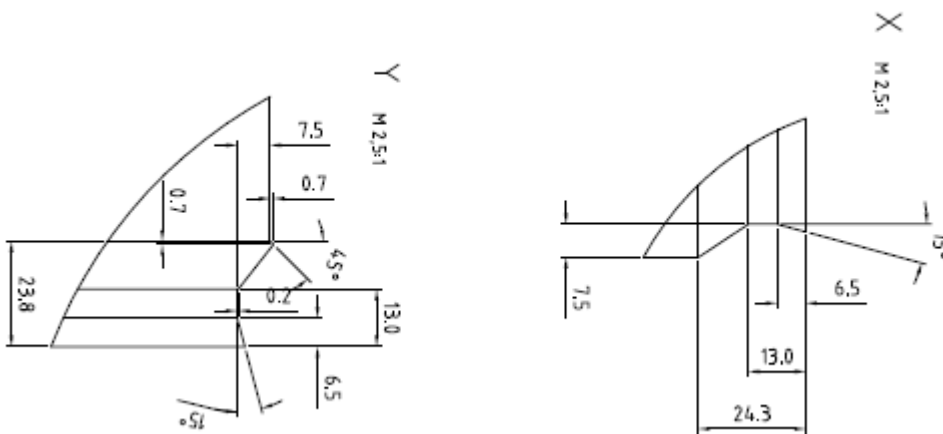
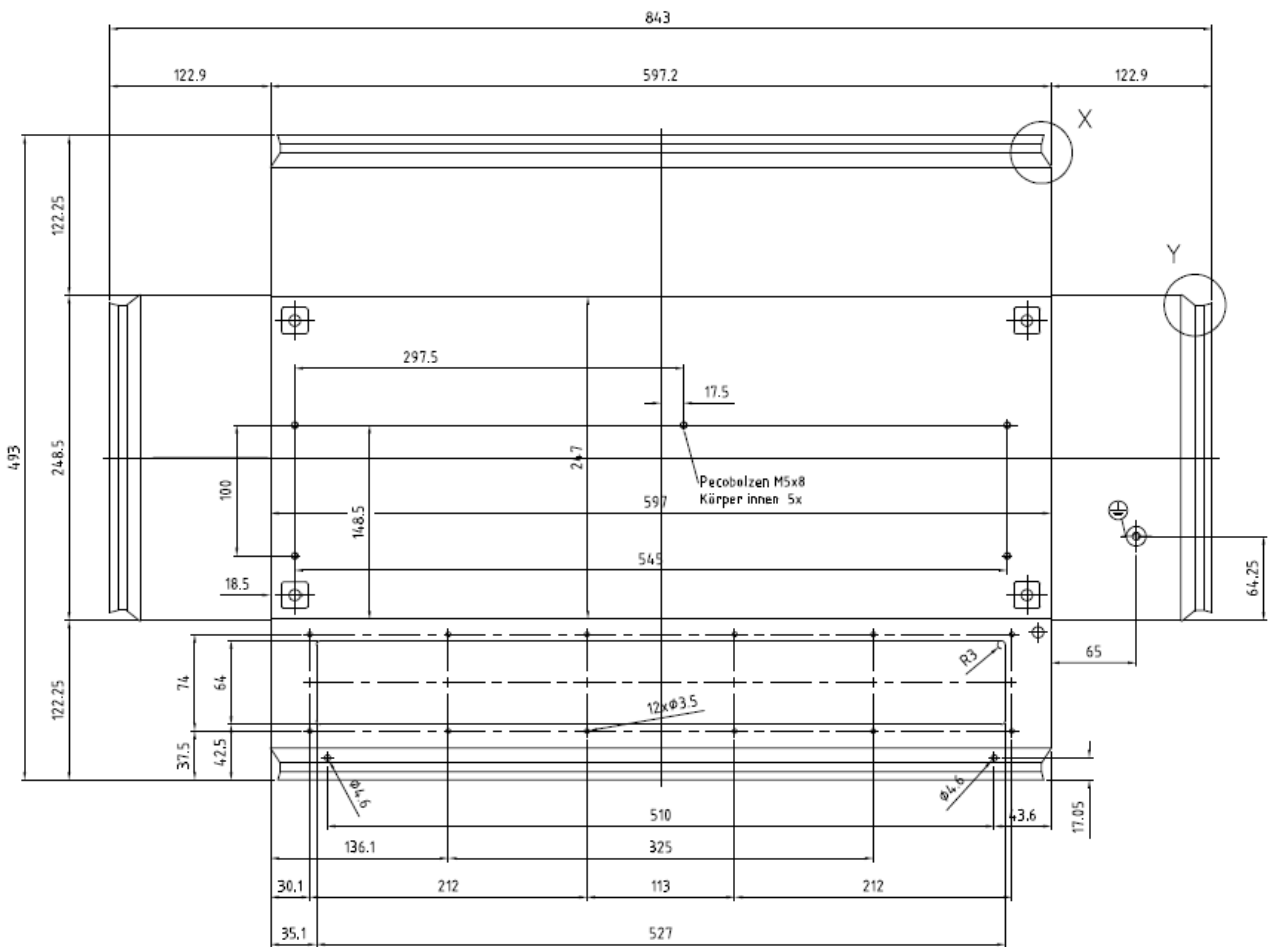

Dimensions	
Width	600.00 mm
Heigh	250.00 mm
Length	125.00 mm
Ordering information	
BG1569	Empty housing for bus terminals and EtherCAT terminals 600 mm x 250 mm x 120 mm (WxHxL) with inspection window with DIN rail, flange plate with bore holes