

Operating Instructions | EN

EL1918 and EL1918-2200

TwinSAFE Terminal with 8 digital fail-safe inputs



Table of contents

1	Notes on the documentation.....	5
1.1	Disclaimer.....	5
1.1.1	Trademarks.....	5
1.1.2	Patents.....	5
1.1.3	Limitation of liability.....	6
1.1.4	Copyright.....	6
1.2	Version numbers of the documentation.....	7
1.3	Version history of the TwinSAFE product.....	9
1.4	References.....	9
1.5	Staff qualification.....	10
1.6	Safety and instruction.....	11
1.7	Beckhoff Support and Service.....	12
2	For your safety.....	13
2.1	Duty of care.....	13
2.2	Safety image signs.....	14
2.3	General safety instructions.....	15
2.3.1	Before operation.....	15
2.3.2	During operation.....	16
2.3.3	After operation.....	16
3	System description.....	17
3.1	The Beckhoff EtherCAT Terminal system.....	17
3.1.1	EtherCAT Bus Coupler.....	18
3.1.2	EtherCAT Terminals.....	19
3.1.3	E-bus.....	20
3.1.4	Power contacts.....	20
3.2	TwinSAFE.....	20
3.2.1	The I/O construction kit is extended safely.....	20
3.2.2	Safety concept.....	20
3.2.3	The fail-safe principle (Fail Stop).....	21
4	Product description.....	22
4.1	EL1918 and EL1918-2200.....	22
4.2	Intended use.....	23
4.3	Technical data.....	25
4.4	Target failure measures.....	26
4.5	Safe input.....	26
4.6	Characteristic curve of the inputs.....	27
4.7	Dimensions.....	28
4.8	Lifetime.....	28
5	Operation.....	30
5.1	Environmental conditions.....	30
5.2	Installation.....	30
5.2.1	Safety instructions.....	30
5.2.2	Transport / storage.....	30

5.2.3	Mechanical installation	30
5.2.4	Electrical installation.....	36
5.3	Configuration of the terminal in TwinCAT	41
5.3.1	Inserting a Bus Coupler.....	41
5.3.2	Inserting a Bus Terminal	41
5.3.3	Adding an EL1918.....	41
5.3.4	Address settings on TwinSAFE terminals with 1023 possible addresses.....	42
5.3.5	Alias devices	43
5.3.6	EL1918 parameters in TwinCAT	44
5.3.7	Process image of the EL1918	46
5.3.8	EL1918: using the integrated TwinSAFE Logic functions	47
5.4	TwinSAFE reaction times.....	48
5.4.1	Typical response time	48
5.4.2	Worst case response time.....	50
5.5	Diagnosis	51
5.5.1	Status LEDs	51
5.5.2	Diagnostic LEDs.....	51
5.5.3	Flash code display	52
5.5.4	Diagnosis History	52
5.5.5	Diag History tab.....	54
5.6	Maintenance.....	56
6	Maintenance and cleaning	57
6.1	Disassembly	57
7	Decommissioning	59
7.1	Disposal	59
7.1.1	Returning to the vendor.....	59
8	Appendix	60
8.1	Volatility.....	60
8.2	Focus of certificates	61

1 Notes on the documentation

1.1 Disclaimer

Beckhoff products are subject to continuous further development. We reserve the right to revise the operating instructions at any time and without prior announcement. No claims for the modification of products that have already been supplied may be made on the basis of the data, diagrams and descriptions in these operating instructions.

In these operating instructions we define all permissible use cases whose properties and operating conditions we can guarantee. The use cases we define are fully tested and certified. Use cases beyond this, which are not described in these operating instructions, require the approval of Beckhoff Automation GmbH & Co KG.

1.1.1 Trademarks

Beckhoff®, TwinCAT®, EtherCAT®, EtherCAT G®, EtherCAT G10®, EtherCAT P®, Safety over EtherCAT®, TwinSAFE®, XFC®, XTS® and XPlanar® are registered and licensed trademarks of Beckhoff Automation GmbH.

The use of other brand names or designations by third parties may lead to an infringement of the rights of the owners of the corresponding designations.

1.1.2 Patents

The EtherCAT technology is protected by patent rights through the following registrations and patents with corresponding applications and registrations in various other countries:

- EP1590927
- EP1789857
- EP1456722
- EP2137893
- DE102015105702



EtherCAT® is a registered trademark and patented technology, licensed by Beckhoff Automation GmbH.



Safety over EtherCAT® is a registered trademark and patented technology, licensed by Beckhoff Automation GmbH.

1.1.3 Limitation of liability

All components in this product as described in the operating instructions are delivered in a specific configuration of hardware and software, depending on the application regulations. Modifications and changes to the hardware and/or software configuration that go beyond the documented options are prohibited and nullify the liability of Beckhoff Automation GmbH & Co. KG.

The following is excluded from the liability:

- Failure to observe these operating instructions
- Improper use
- Use of untrained personnel
- Use of unauthorized spare parts

1.1.4 Copyright

© Beckhoff Automation GmbH & Co. KG, Germany.

The distribution and reproduction of this document as well as the use and communication of its contents without express authorization are prohibited.

Offenders will be held liable for the payment of damages. All rights reserved in the event of the grant of a patent, utility model or design.

1.2 Version numbers of the documentation

Version	Comment
2.2.2	<ul style="list-style-type: none"> • New fonts undone
2.2.1	<ul style="list-style-type: none"> • Chapter "Due diligence" extended • Chapter "Service life" moved • Designation "Safety parameters" changed to "Target failure measures" • "Service life" changed to "Lifetime" • Chapter renamed to "Version numbers of the documentation" • New fonts • Corrections
2.2.0	<ul style="list-style-type: none"> • Operating temperature extended in chapter "Technical data"
2.1.0	<ul style="list-style-type: none"> • Chapter "Safety and instruction" revised • In chapter "Technical data" corrosive gas test and footnote for corrosive environment added • Warning added to chapter "Mounting rail installation" • Chapter "Service life" revised • Certificate removed
2.0.0	<ul style="list-style-type: none"> • Foreword changed to "Documentation notes" and "For your safety" • "Maintenance and cleaning" and "Decommissioning" adapted • Appendix adapted and extended
1.3.1	<ul style="list-style-type: none"> • Corrections
1.3.0	<ul style="list-style-type: none"> • Firmware 02 added to chapter "Version history of the TwinSAFE product" • Added a link to certificate download page in chapter "Technical data" • Chapter "Firmware update of TwinSAFE products" removed • I/O component EL1918-2200 added as variant of EL1918 • Chapter "Pin assignment" renamed • Chapter "Project design limits of the EL1918" moved
1.2.0	<ul style="list-style-type: none"> • Project design limits added
1.1.0	<ul style="list-style-type: none"> • Restrictions on channel use amended • Note on commissioning added
1.0.0	<ul style="list-style-type: none"> • Certificate added • Connection added • First released version
0.0.3	<ul style="list-style-type: none"> • System limits added • Description of <i>Module Fault Link active</i> parameter added. • Version history updated • References added • Description of local logic function added • Foreword updated • Safety instructions adapted to IEC 82079-1.
0.0.2	<ul style="list-style-type: none"> • Update after review
0.0.1	<ul style="list-style-type: none"> • First draft

Currentness

Please check whether you are using the current and valid version of this document. The current version can be downloaded from the Beckhoff homepage at <http://www.beckhoff.com/twinsafe>. In case of doubt, please contact Technical Support (see [Beckhoff Support and Service \[► 12\]](#)).

Origin of the document

The original documentation is written in German. All other languages are derived from the German original.

Product features

Only the product properties specified in the current operating instructions are valid. Further information given on the product pages of the Beckhoff homepage, in emails or in other publications is not authoritative.

1.3 Version history of the TwinSAFE product

This version history lists the software and hardware version numbers. A description of the changes compared to the previous version is also given.

i Updated hardware and software

TwinSAFE products are subject to a cyclical revision. We reserve the right to revise and change the TwinSAFE products at any time and without prior notice.

No claims for changes to products already delivered can be asserted from these hardware and/or software changes.

Date	Software version	Hardware version	Modifications
			First release of the EL1918-2200
2022-03-25	02	00	<ul style="list-style-type: none"> • New function blocks SBT and SLP • Prevention of unauthorized firmware downgrade • Updating the modules
2018-08-03	01	00	First release of the EL1918

1.4 References

No.	Version	Description
[1]	/	Not used.
[2]	/	Not used.
[3]	1.4.1 or newer	<p>Operating Manual for EL6910 TwinSAFE Logic Module</p> <p>The document contains a description of the logic functions of the EL6910 and its programming.</p>
[4]	3.1.0 or newer	<p>Dokumentation TwinSAFE-Logic-FB</p> <p>The document describes the safety-related function blocks that are available in the EL6910 and thus also in the TwinSAFE card and form the safety-related application.</p>
[5]	3.1.0 or newer	<p>TwinSAFE Application Guide</p> <p>The application guide provides the user with examples for the calculation of safety-related parameters for safety functions according to the standards DIN EN ISO 13849-1 and EN 62061 or EN 61508:2010, as they are typically used on machines.</p>
[6]	2006/42/EG	<p>Directive 2006/42/EC of the European Parliament and of the Council of 17 May 2006 on machinery and amending Directive 95/16/EC (recast) of 9.6.2006</p> <p>This directive, also known as the Machinery Directive, defines requirements for the placing on the market of machines and machine-like components, such as safety components.</p>

1.5 Staff qualification

These operating instructions are intended exclusively for trained specialists in control technology and automation with the relevant knowledge.

The trained specialist personnel must ensure that the applications and use of the described product meet all safety requirements. This includes all applicable and valid laws, regulations, provisions and standards.

Trained specialists

Trained specialists have extensive technical knowledge from studies, apprenticeships or technical training. Understanding of control technology and automation is available. Trained specialists can:

- Independently identify, avoid and eliminate sources of hazard.
- Apply relevant standards and directives.
- Implement specifications from accident prevention regulations.
- Evaluate, prepare and set up the workplaces.
- Evaluate, optimize and execute work independently.

1.6 Safety and instruction

Read the contents that refer to the activities you have to perform with the product. Always read the chapter [For your safety \[▶ 13\]](#) in the operating instructions.

Observe the warnings in the chapters so that you can handle and work with the product as intended and safely.

Explanation of symbols

Various symbols are used for a clear arrangement:

1. The numbering indicates an action that should be taken.
 - The bullet point indicates an enumeration.
- [...] The square brackets indicate cross-references to other text passages in the document.
- [1] The number in square brackets indicates the numbering of a referenced document.

The signal words used in the documentation are classified below.

Signal words

Warning of personal injuries

DANGER

Hazard with high risk of death or serious injury.

WARNING

Hazard with medium risk of death or serious injury.

CAUTION

There is a low-risk hazard that could result in medium or minor injury.

Warning of damage to property or environment

NOTICE

Notes

The environment, equipment, or data may be damaged.

Information on handling the product



This information includes, for example:
Recommendations for action, assistance or further information on the product.

1.7 Beckhoff Support and Service

Support

Beckhoff Support offers technical advice on the use of individual Beckhoff products and system planning. The employees support you in the programming and commissioning of sophisticated automation systems.

Hotline: +49 5246/963-157
E-mail: support@beckhoff.com
Web: www.beckhoff.com/support

Training

Training in Germany takes place in our training center at the Beckhoff headquarters in Verl, at subsidiaries or, by arrangement, at the customer's premises.

Hotline: +49 5246/963-5000
E-mail: training@beckhoff.com
Web: www.beckhoff.com/training

Service

The Beckhoff Service Center supports you with after-sales services such as on-site service, repair service or spare parts service.

Hotline: +49 5246/963-460
E-mail: service@beckhoff.com
Web: www.beckhoff.com/service

Download area

In the download area you can obtain product information, software updates, the TwinCAT automation software, documentation and much more.

Web: www.beckhoff.com/download

Headquarters

Beckhoff Automation GmbH & Co. KG
Hülshorstweg 20
33415 Verl
Germany

Phone: +49 5246/963-0
E-mail: info@beckhoff.com
Web: www.beckhoff.com

For the addresses of our worldwide locations, please visit our website at [Global Presence](#).

2 For your safety

Read this chapter containing general safety information. In addition, always observe the safety instructions and warnings in these operating instructions for your own safety, the safety of other persons and the safety of the product.

When working with control and automation products, many dangers can result from careless or incorrect use. Work particularly thoroughly, not under time pressure and responsibly towards other people.

2.1 Duty of care



Read entire documentation for TwinSAFE component

- TwinSAFE application manual
- EL6910 TwinSAFE logic terminal operating manual
- TwinSAFE Logic FB documentation manual

The operator must comply with all the requirements and notes specified in these operating instructions in order to fulfill his duty of care. This includes in particular that you

- comply with the provisions defined in the chapter [Limitation of liability](#) [▶ 6].
- only operate the TwinSAFE component when it is in perfect working order.
- provide the operating instructions in a legible condition and complete at the place of use of the TwinSAFE component.
- do not remove the safety markings attached to the TwinSAFE component and maintain their legibility.

The operator is also responsible for the safe operation of the system. This includes risk assessment. The following standards apply for risk assessment:

- EN ISO 12100:2010, Safety of machinery – General principles for design – Risk assessment and risk reduction
- ISO 13849-1, Safety of machinery – Safety-related parts of control systems – Part 1: General principles for design

Beckhoff is not responsible for the safe operation of the system.



No disposal in domestic waste

Products marked with a crossed-out waste bin must not be disposed of with domestic waste. The device is considered waste electrical and electronic equipment when it is disposed of. Observe the national regulations for the disposal of waste electrical and electronic equipment.

2.2 Safety image signs

Beckhoff products feature safety pictograms, either on stickers or printed, which vary depending on the product. They serve to protect people and to prevent damage to the products. Safety pictograms may not be removed and must be legible for the user.

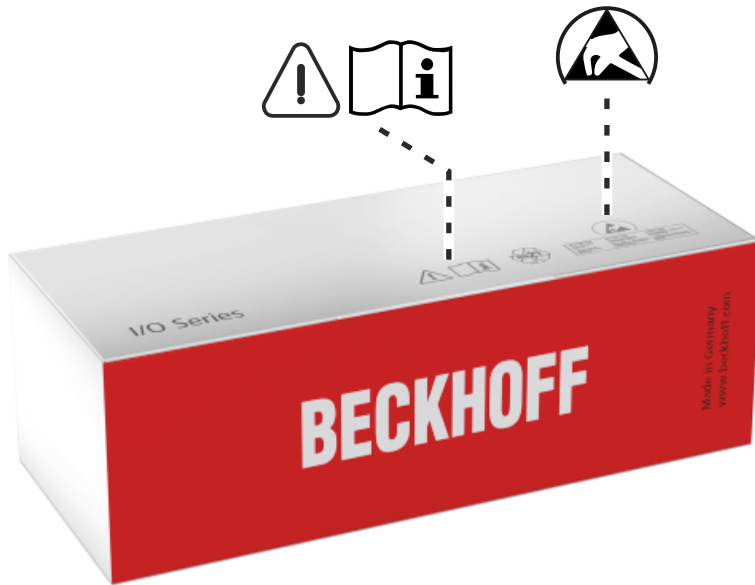

Read and observe the operating instructions

Commissioning is only permitted if the operating instructions have been read and understood beforehand. This applies in particular to the safety instructions and the warnings.



Electrostatic sensitive components

Work with and on the TwinSAFE component is only permitted at protected workplaces.

2.3 General safety instructions

This chapter contains safety instructions for handling the product. This product is a safety component as defined by the Machinery Directive. The product must be installed in a machine or system by the machine builder and is used to ensure the safety function. Safety components are not required for the functioning of a machine. However, a failure or malfunction of safety components will result in a hazard to personal safety. Read the documentation prepared by the machine builder.

2.3.1 Before operation

Use in machines according to the Machinery Directive

Only use the TwinSAFE component in machines that comply with the Machinery Directive. This is how you ensure safe operation.

For more information, see the document [6] at [References](#) [► 9].

Ensure traceability

Ensure the traceability of the TwinSAFE component via the serial number.

Use SELV/PELV power supply

Use a SELV/PELV power supply unit with an output-side voltage limit of $U_{\max} = 36 V_{\text{DC}}$ to supply the TwinSAFE component with $24 V_{\text{DC}}$.

Failure to observe this will endanger the safety function of the product. Depending on the machine, death and danger to life, serious physical injury and damage to the machine may result.

Carry out commissioning test

Before commissioning, wiring faults to the sensors must be excluded. Before commissioning, carry out a commissioning test. After a successful commissioning test, you can use the TwinSAFE component for the intended safety-related task.

In case of wiring errors, the safety function of the product is at risk. Depending on the machine, death and danger to life, serious bodily injury and damage to the machine may result.

Use of permissible engineering tools and procedures

The TÜV SÜD certificate applies to these TwinSAFE components, the function blocks available in it, the documentation and the engineering tool. *TwinCAT 3.1* and the *TwinSAFE Loader* are permitted as engineering tools.

Procedures or engineering tools that deviate from this are not covered by the certificate. This is especially true for externally generated xml files for the TwinSAFE import.

2.3.2 During operation

Interference due to emitted interference

Do not operate the following devices in the vicinity of the TwinSAFE component: for example, radio telephones, radios, transmitters or high-frequency systems.

TwinSAFE components comply with the requirements of the applicable electromagnetic compatibility standards with regard to interference emission and immunity. If you exceed the limits for emitted interference specified in the standards, the function of the TwinSAFE component may be impaired.

2.3.3 After operation

De-energize and switch off components before working on them

Check all safety-relevant equipment for functionality before working on the TwinSAFE component. Secure the working environment. Secure the machine or plant against being inadvertently started up. Observe the chapter [Decommissioning](#) [► 59].

3 System description

3.1 The Beckhoff EtherCAT Terminal system

The Beckhoff EtherCAT Terminal system is used for decentralized connection of sensors and actuators to a controller. The components of the Beckhoff EtherCAT Terminal system are mainly used in industrial automation and building management systems. As a minimum, a bus station consists of an EtherCAT Coupler and connected EtherCAT Terminals. The EtherCAT Coupler forms the communication interface to the higher-level controller, while the EtherCAT Terminals form the interface to the sensors and actuators. The whole bus station is clipped onto a 35 mm DIN mounting rail (EN 60715). The mechanical link of the bus station is established with a slot and key system on EtherCAT Couplers and EtherCAT Terminals.

The sensors and actuators are connected with the terminals via the screwless (spring-loaded) connection system.

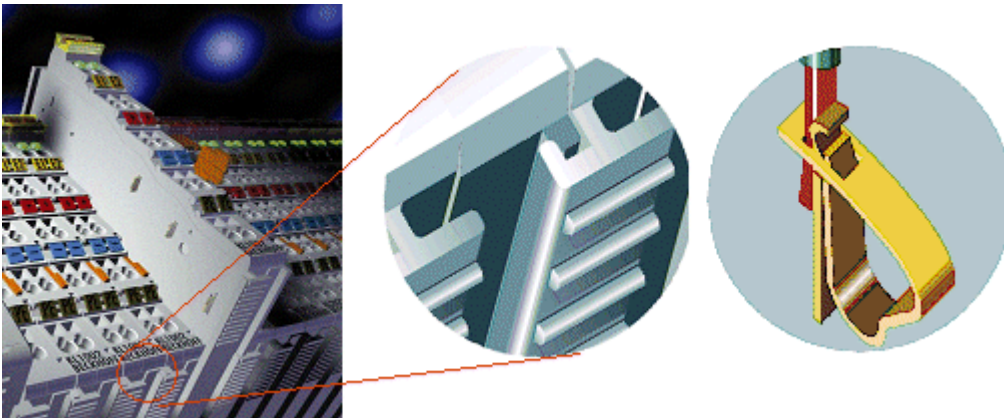

Fig. 1: Slot and key system and screwless (spring-loaded) connection system

3.1.1 EtherCAT Bus Coupler

Mechanical data	Bus Coupler
Material	polycarbonate, polyamide (PA6.6).
Dimensions (W x H x D)	44 mm x 100 mm x 68 mm
Mounting	on 35 mm mounting rail (EN 60715) with locking
Attachable by	double slot and key connection

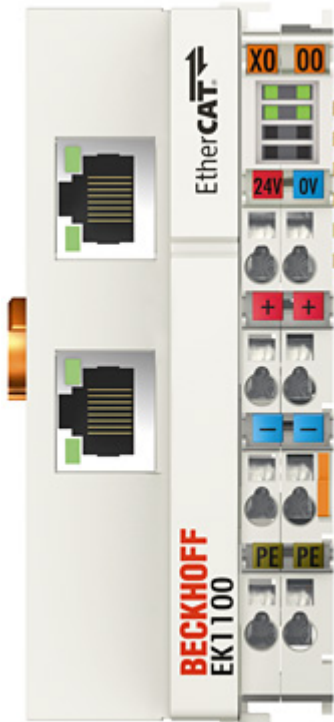

Fig. 2: Bus Coupler (EtherCAT)

Connection technology	Bus Coupler
Wiring	Spring-loaded system
Connection cross-section	0.08 mm ² ... 2.5 mm ² , stranded wire, solid wire
Fieldbus connection	EtherCAT
Power contacts	3 spring contacts
Current load	10 A
Nominal voltage	24 V _{DC}

3.1.2 EtherCAT Terminals

Mechanical data	Bus Terminal
Material	polycarbonate, polyamide (PA6.6).
Dimensions (W x H x D)	12 mm x 100 mm x 68 mm or 24 mm x 100 mm x 68 mm
Mounting	on 35 mm mounting rail (EN 60715) with locking
Attachable by	double slot and key connection

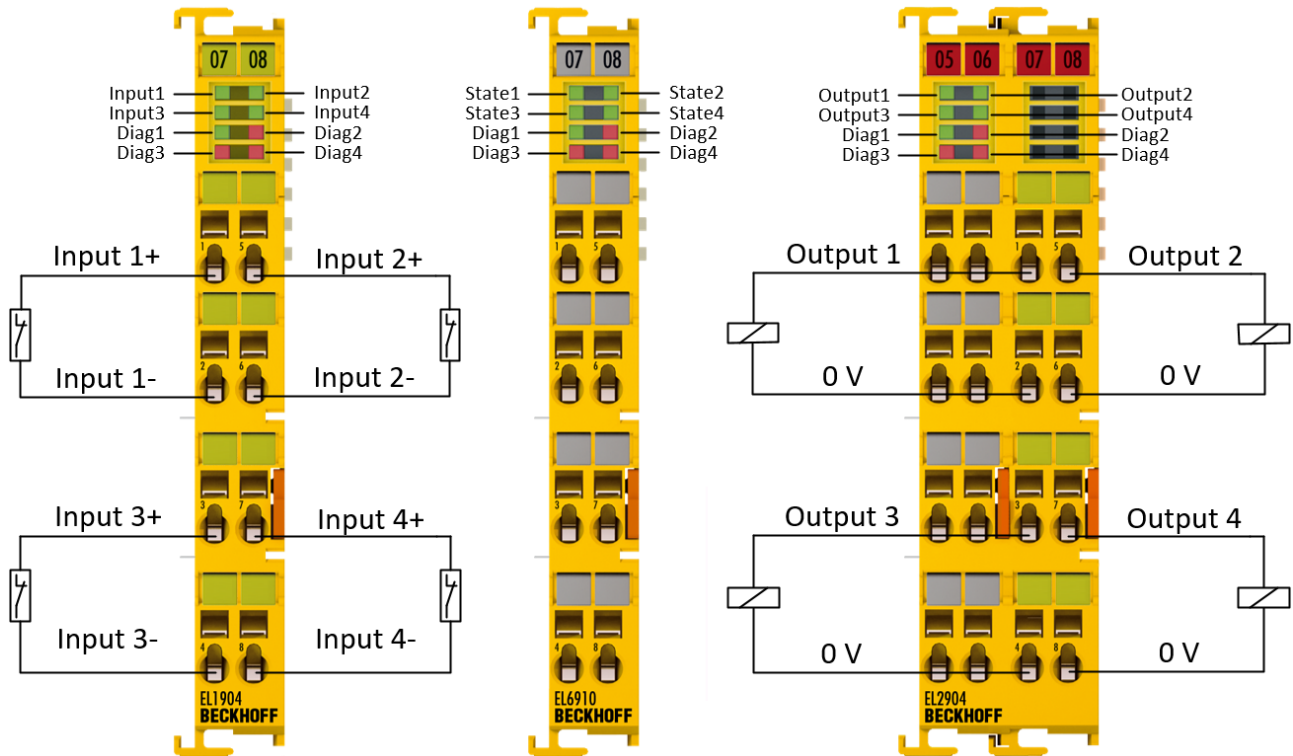

Fig. 3: Overview of EtherCAT Terminals

Connection technology	Bus Terminal
Wiring	Spring-loaded system
Connection cross-section	typically 0.08 mm ² – 2.5 mm ² , stranded wire, solid wire
Communication	E-bus
Power contacts	Up to 3 blade/spring contacts
Current load	10 A
Nominal voltage	Depending on terminal type (typically 24 V _{DC})

3.1.3 E-bus

The E-bus is the data path within a terminal strip. The E-bus is led through from the Bus Coupler through all the terminals via six contacts on the terminals' side walls.

3.1.4 Power contacts

The operating voltage is passed on to following terminals via three power contacts. Terminal strip can be split into galvanically isolated groups by means of potential supply terminals as required. The supply terminals play no part in the control of the terminals, and can be inserted at any locations within the terminal strip.

3.2 TwinSAFE

3.2.1 The I/O construction kit is extended safely

The integrated TwinSAFE safety solution is the logical continuation of the open, PC-based Beckhoff control philosophy. Due to their modularity and versatility, the TwinSAFE components fit seamlessly into the Beckhoff control system. The I/O components are available in the formats Bus Terminal, EtherCAT Terminal, EtherCAT plug-in module and EtherCAT Box.

Thanks to the fieldbus-neutral safety protocol (TwinSAFE/Safety-over-EtherCAT), TwinSAFE devices can be integrated into any fieldbus system. They are integrated into existing networks with K-bus or EtherCAT and can be used directly in the machine as IP 67 modules. These safety I/Os form the interfaces to the safety-relevant sensors and actuators.

The possibility to transmit the safety-relevant signals over a standard bus system gives rise to substantial advantages in terms of planning, installation, operation, maintenance, diagnostics and costs.

The safety application is configured or programmed respectively in the TwinCAT software. This application is then transferred via the bus to a TwinSAFE logic component. These form the heart of the TwinSAFE system. All safety devices in the system communicate with this logic component. Due to the enormous flexibility of the system, several TwinSAFE logic components can also be operated simultaneously in a network.

3.2.2 Safety concept

TwinSAFE: Safety and I/O technology in one system

- Extension of the familiar Beckhoff I/O system with TwinSAFE Terminals
- Freely selectable mix of safe and standard signals
- Logic link of the I/Os in the TwinSAFE logic component, e.g. EL6910
- Safety-relevant networking of machines via bus systems

TwinSAFE protocol (FSoE / Safety-over-EtherCAT)

- Transfer of safety-relevant data via any media ("genuine black channel")
- TwinSAFE communication via fieldbus systems such as EtherCAT, Lightbus, PROFIBUS or Ethernet
- IEC 61508:2010 SIL 3 compliant

TwinCAT software and TwinSAFE editor

- Safety application is configured or programmed in the TwinCAT software
- Certified function blocks such as emergency stop, operation mode, etc.
- simple handling
- Transfer of the application via the bus to the TwinSAFE logic component

TwinSAFE logic component, e.g. EL6910

- Processing of the safety-related application and communication with the TwinSAFE terminals
- No safety requirements for higher-level control system
- TwinSAFE enables a network with up to 65,535 TwinSAFE components.
- TwinSAFE logic component can establish up to 512 connections (TwinSAFE connections).
- Several TwinSAFE logic components can be operated in a network
- Suitable for applications up to SIL 3 according to IEC 61508:2010 and category 4 / PL e according to EN ISO 13849-1:2015.

TwinSAFE I/O components

- The TwinSAFE I/O components are available in the formats Bus Terminal, EtherCAT Terminal, EtherCAT plug-in module, EtherCAT Box and TwinSAFE Drive option card
- All common safety sensors and actuators can be connected
- Operation with a TwinSAFE logic component
- Typically meet the requirements of IEC 61508:2010 up to SIL 3 and EN ISO 13849-1:2015 up to Category 4, PL e. More detailed information can be found in the respective user documentation

3.2.3 The fail-safe principle (Fail Stop)

The basic rule for a safety system such as TwinSAFE is that failure of a part, a system component or the overall system must never lead to a dangerous condition.

⚠ CAUTION**Safe state!**

The safe state of the TwinSAFE system is always the **switched-off** and **de-energized** state.

4 Product description

4.1 EL1918 and EL1918-2200

The EL1918 is a digital input terminal for sensors with potential-free contacts for 24 V_{DC}. The TwinSAFE Terminal has 8 fail-safe inputs.

With a two-channel connection, the EL1918 meets the requirements of IEC 61508:2010 SIL 3 and EN ISO 13849-1:2015 (Cat 4, PL e). See chapter [Safe input \[► 26\]](#).

The TwinSAFE terminal has the typical design of an EtherCAT HD Terminal.

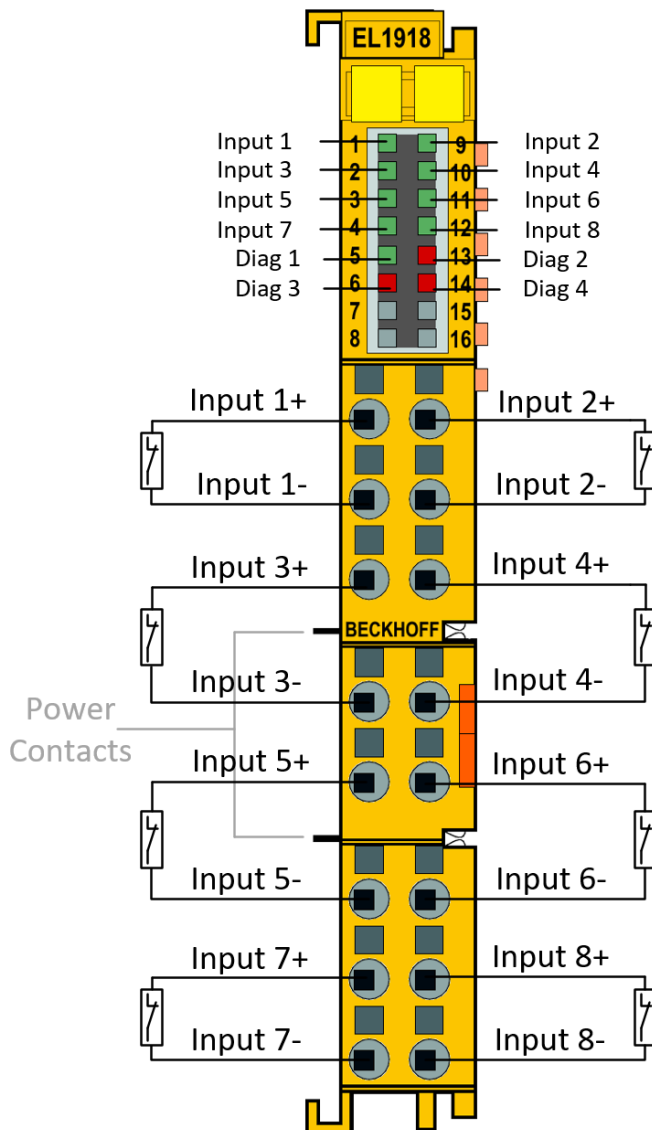

Fig. 4: EL1918 – TwinSAFE Terminal with 8 fail-safe inputs



EL1918 variants

The EL1918 has an integrated safety control that can be used for user-specific applications directly on the component. The variant EL1918-2200 does not have this functionality and represents a pure I/O component.

4.2 Intended use

⚠ WARNING

Caution - Risk of injury!

TwinSAFE components may only be used for the purposes described below!

The TwinSAFE Terminals expand the application area of Beckhoff Bus Terminal system with functions that enable them to be used for machine safety applications. The TwinSAFE Terminals are designed for machine safety functions and directly associated industrial automation tasks. They are therefore only approved for applications with a defined fail-safe state. This safe state is the switched-off and de-energized state. Fail-safety according to the relevant standards is required.

The TwinSAFE I/O components allow the connection of:

- 24 V_{DC} sensors such as emergency stop push-buttons, rope pull switches, position switches, two-hand switches, safety switching mats, light curtains, light barriers, laser scanners, etc.
- 24 V_{DC} actuators such as contactors, protective door switches with tumbler, signal lamps, servo drives, etc.

● Test pulses

i When selecting actuators please ensure that the test pulses of the TwinSAFE component do not lead to switching of the actuator or a diagnostic message of the TwinSAFE component.

The following TwinSAFE components were developed for these tasks:

- The EL1904 is an EtherCAT Terminal with 4 digital fail-safe inputs
- The EL2904 is an EtherCAT Terminal with 4 digital fail-safe outputs
- The EL6910 is an EtherCAT Terminal with integrated TwinSAFE logic

These TwinSAFE components are suitable for operation on the

- Beckhoff EKxxxx series Bus Couplers
- Beckhoff CXxxxx series Embedded PCs with E-bus connection

⚠ WARNING

System limits

The TÜV SÜD certificate applies to this TwinSAFE component, the function blocks available in it, the documentation and the engineering tool. *TwinCAT 3.1* and the *TwinSAFE Loader* are permitted as engineering tools. Any deviations from these procedures or tools, particularly externally generated xml files for TwinSAFE import or externally generated automatic project creation procedures, are not covered by the certificate.

⚠ WARNING

Power supply from SELV/PELV power supply unit!

The TwinSAFE components must be supplied with 24 V_{DC} by an SELV/PELV power supply unit with an output voltage limit U_{max} of 36 V_{DC}. Failure to observe this can result in a loss of safety.

⚠ WARNING

Commissioning test

Before the EL1918 can be used for safety-related tasks, a commissioning test must be carried out by the user so that faulty sensor wiring can be ruled out.

⚠ CAUTION

Follow the machinery directive!

The TwinSAFE components may only be used in machines as defined in the machinery directive.

⚠ CAUTION**Ensure traceability!**

The buyer has to ensure the traceability of the device via the serial number.

⚠ CAUTION**Note on approval according to EN 81-20, EN 81-22 and EN 81-50**

- The release does **not** apply to the EL1918-2200, EL2911-2200 and EP1957-2222 variants.
- The TwinSAFE components may only be used in machines that have been designed and installed in accordance with the requirements of the EN 60204-1 standard.
- Provide a surge filter for the supply voltage of the TwinSAFE components against overvoltages (reduction to overvoltage category II).
- EN 81 requires that in the case of devices with internal temperature monitoring, a stop must be reached in the event of an overtemperature. In this case, passengers must be able to disembark (see EN 81-20 chapter 5.10.4.3, for example). To ensure this, application measures are necessary. The internal terminal temperature of the TwinSAFE components can be read out by the user. A direct switch-off occurs at the maximum permissible temperature of the respective TwinSAFE component (see chapter Temperature measurement).
The user must select a temperature threshold below the maximum temperature such that a stop can be reached in all cases before the maximum temperature is reached. Information on the optimum terminal configuration can be found under Notes on the arrangement of TwinSAFE components and under Example configuration for temperature measurement.
- For the use of the TwinSAFE components according to EN 81-22 and EN 81-50, the conditions described in the manuals for achieving category 4 according to EN ISO 13849-1:2015 **must** be observed.
- The use of TwinSAFE components is limited to indoor applications.
- Basic protection against direct contact must be provided, either by fulfilling protection class IP2X or by installing the TwinSAFE components in a control cabinet which corresponds at least to protection class IP54 according to EN 60529.
- The ambient conditions regarding temperature, humidity, heat dissipation, EMC and vibrations, as specified in the operating instructions under technical data, must be observed.
- The operating conditions in potentially explosive atmospheres (ATEX) are specified in the operating instructions.
- The safe state (triggering) of the application must be the de-energized state. The safe state of the TwinSAFE components is always the de-energized, switched-off state, and this cannot be changed.
- The lifetime specified in the operating instructions must be observed.
- If the TwinSAFE component is operated outside the permissible temperature range, it changes to "Global Shutdown" state.
- The TwinSAFE components must be installed in a control cabinet with protection class IP54 according to EN 60529, so that the requirement for degree of pollution 3 according to EN 60664-1 can be reduced to level 2.
- The TwinSAFE components must be supplied by a SELV/PELV power supply unit with a maximum voltage of $U_{\max} \leq 36 V_{DC}$.

4.3 Technical data

The current certificates of all TwinSAFE products with the underlying standards and directives can be found at <https://www.beckhoff.com/en-en/support/download-finder/certificates-approvals/>.

Product designation	EL1918 and EL1918-2200
Number of inputs	8
Status display	12 (one green LED per input + 4 DIAG LEDs)
Response time (read input/write to E-bus)	typically: 4 ms, maximum: see fault reaction time
Fault reaction time	≤ watchdog time
Cable length between sensor and terminal	unshielded max. 100 m (with 0.75 or 1 mm ²) shielded max. 100 m (with 0.75 or 1 mm ²)
Output current of the clock outputs	typically 3 mA, max. 6.5 mA
Input process image	7 bytes
Output process image	6 bytes
Supply voltage of the EL1918 (PELV)	24 V _{DC} (-15% / +20%)
Signal voltage "0" inputs	-3 V ... 5 V (EN 61131-2, type 3) see chapter Characteristic curve of the inputs [▶ 27]
Signal voltage "1" inputs	11 V ... 30 V (EN 61131-2, type 3) see chapter Characteristic curve of the inputs [▶ 27]
Current consumption of the module electronics at 24 V (without current consumption of sensors)	8 channels occupied: typically 29.6 mA (@28.8 V _{DC}) 0 channels occupied: typically 2.27 mA (@28.8 V _{DC})
Current consumption via E-bus	8 channels occupied: approx. 165 mA
Power loss of the terminal	typically 1.6 W
Electrical isolation (between the channels)	No
Electrical isolation (between the channels and the E-bus)	Yes
Insulation voltage (between the channels and the E-bus, under common operating conditions)	Insulation tested with 500 V _{DC}
Dimensions (W x H x D)	12 mm x 100 mm x 68 mm
Weight	approx. 50 g
Permissible ambient temperature (operation)	-30°C to +55°C (observe the chapter Temperature measurement [▶ 32])
Permissible ambient temperature (transport/storage)	-40 °C to +70 °C
Permissible air humidity	5% to 95%, non-condensing
Permissible air pressure (operation/storage/transport)	750 hPa to 1100 hPa (this is equivalent to an altitude of approx. -690 m to 2450 m above sea level assuming an international standard atmosphere)
Climate category according to EN 60721-3-3	3K3 (the deviation from 3K3 is possible only with optimal environmental conditions and also applies only to the technical data which are specified differently in this documentation)
Permissible pollution degree according to EN 60664-1	Pollution degree 2 (please note the chapter Maintenance [▶ 56])
Inadmissible operating conditions	TwinSAFE terminals must not be used under the following operating conditions: <ul style="list-style-type: none"> • under the influence of ionizing radiation (exceeding the natural background radiation) • in corrosive environments¹ • in an environment that leads to unacceptable contamination of the TwinSAFE component
EMC immunity / emission	conforms to EN 61000-6-2 / EN 61000-6-4
Vibration / shock resistance	conforms to EN 60068-2-6 / EN 60068-2-27
Shocks	15 g with pulse duration 11 ms in all three axes
Corrosive gas test	Conforms to DIN EN 60068-2-60:2016-06, method 4 with increased concentrations according to ANSI/ISA 71.04:2013 Level GX Group A <ul style="list-style-type: none"> • Test duration: 21 days • Hydrogen sulfide: (50 ± 5) ppb • Nitrogen dioxide: (1250 ± 20) ppb • Chlorine: (10 ± 5) ppb • Sulfur dioxide: (300 ± 20) ppb

Product designation	EL1918 and EL1918-2200
Protection rating	IP20
Permitted operating environment	In the control cabinet or terminal box, with minimum protection rating IP54 according to IEC 60529
Permissible installation position	see chapter Installation position and minimum distances [► 31]
Approvals	CE, TÜV SÜD

¹ A corrosive environment exists when corrosion damage becomes apparent.

4.4 Target failure measures

Key data	EL1918 and EL1918-2200
Lifetime [a]	20
Proof test Interval [a]	not required ¹
PFH _D	3.00 E-09
PFD	4.90 E-05
MTTF _D	High
DC	High
Performance level	PL e
Category	4
HFT	1
Classification element ²	Type B

1. Special proof tests are not required during the entire lifetime of the EtherCAT Terminal.
2. Classification according to IEC 61508-2:2010 (chapter 7.4.4.1.2 and 7.4.4.1.3)

The EtherCAT Terminals can be used for safety-related applications within the meaning of IEC 61508:2010 up to SIL 3 and EN ISO 13849-1:2015 up to PL e (Cat4).

Further information on calculating or estimating the MTTF_D value from the PFH_D value can be found in the TwinSAFE Application Guide or in EN ISO 13849-1:2015, Table K.1.

Safety over EtherCAT communication is already included in the target failure measures with 1% of SIL 3 according to the protocol specification.

4.5 Safe input

The safe inputs and associated clock outputs are implemented as a single channel for each module. This has the advantage that any channels, e.g. for a two-channel safe sensor, can be combined and used. For error evaluation of these two channels, the *Module Fault Link active* parameter of the two modules involved must be set to TRUE. This is the default state of this parameter.

DANGER

Clocked signals inside a sheathed cable

If clocked signals (clock outputs for the safe inputs) of different modules are used within a sheathed cable, a fault of one module, such as cross-circuit or external feed, must lead to the disconnection of all of these modules. This is achieved by setting the *Module Fault Link active* parameter for all modules involved. This parameter is set to TRUE by default.

DANGER

Safe inputs in Kat.4 / PL e

If two safe input channels are to be used in a Category 4 structure, please ensure that you always combine an even and an odd channel number.

4.6 Characteristic curve of the inputs

The characteristic curve of the inputs is similar to type 3 according to EN 61131-2.

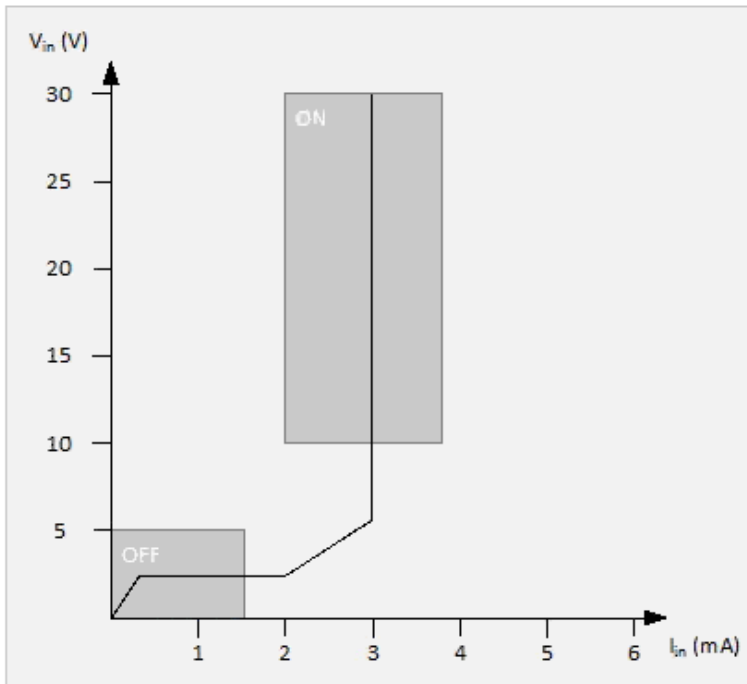

Fig. 5: Characteristic curve of the inputs

4.7 Dimensions

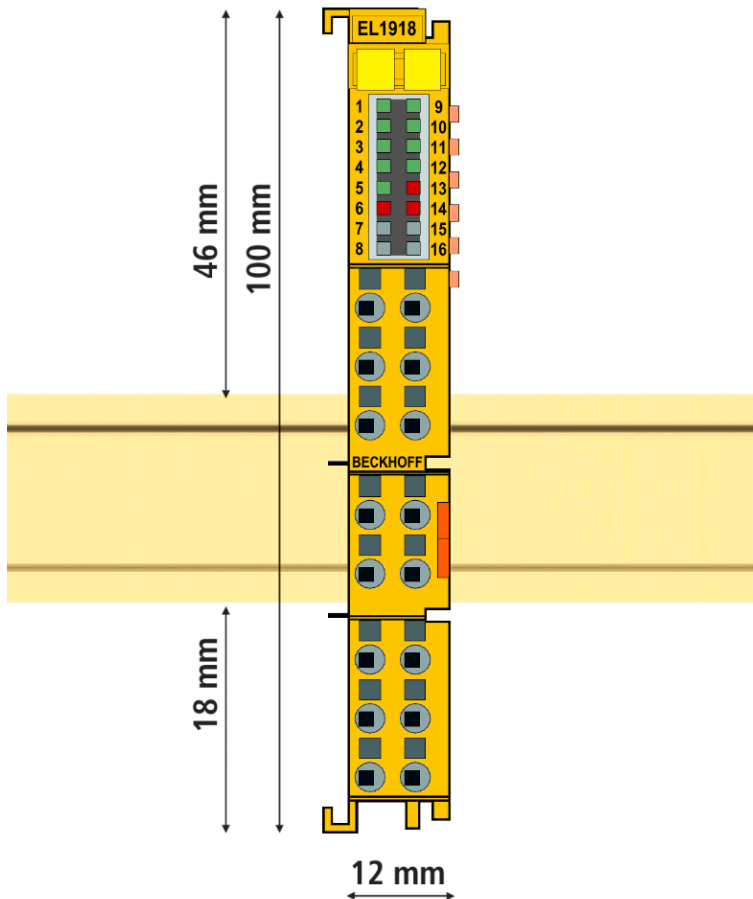

Fig. 6: EL1918 dimensions

Width: 12 mm (side-by-side installation)

Height: 100 mm

Depth: 68 mm

4.8 Lifetime

TwinSAFE components have a lifetime of 20 years, during which the target failure measures are guaranteed. For more information, see the chapter Target failure measures.

The lifetime starts from the date of manufacture according to the Date Code.

⚠ WARNING

Replace TwinSAFE component after 20 years

After a lifetime of 20 years, the target failure measures are no longer guaranteed.

Use beyond the lifetime may result in loss of safety.

Due to the high diagnostic coverage within the lifetime no special proof tests are required.

The TwinSAFE components bear a Date Code, which is composed as follows:

Date Code: CW YY SW HW

Legend:

CW: calendar week of manufacture

JJ: year of manufacture

SW: software version

HW: hardware version

Example: Date Code 17 11 05 00

Calendar week: 17

Year: 2011

Software version: 05

Hardware version: 00

In addition the TwinSAFE components bear a unique serial number.

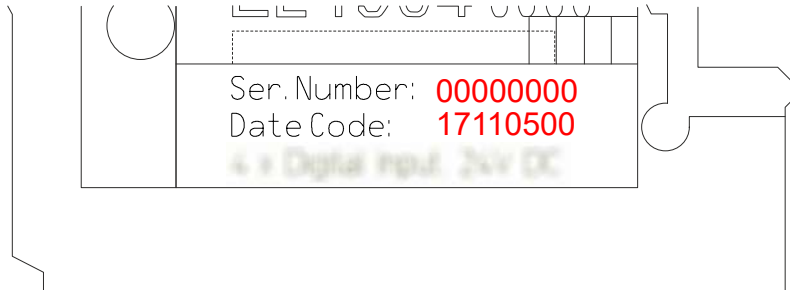

5 Operation

5.1 Environmental conditions

Please ensure that the TwinSAFE components are only transported, stored and operated under the specified conditions (see technical data)!

WARNING

Risk of injury!

The TwinSAFE components must not be used under the following operating conditions.

- under the influence of ionizing radiation (that exceeds the level of the natural environmental radiation)
- in corrosive environments
- in an environment that leads to unacceptable soiling of the TwinSAFE component

NOTICE

Electromagnetic compatibility

The TwinSAFE components comply with the current standards on electromagnetic compatibility with regard to spurious radiation and immunity to interference in particular.

However, in cases where devices such as mobile phones, radio equipment, transmitters or high-frequency systems that exceed the interference emissions limits specified in the standards are operated near TwinSAFE components, the function of the TwinSAFE components may be impaired.

5.2 Installation

5.2.1 Safety instructions

Before installing and commissioning the TwinSAFE components please read the safety instructions in the foreword of this documentation.

5.2.2 Transport / storage

Use the original packaging in which the components were delivered for transporting and storing the TwinSAFE components.

CAUTION

Note the specified environmental conditions

Please ensure that the digital TwinSAFE components are only transported and stored under the specified environmental conditions (see technical data).

5.2.3 Mechanical installation

WARNING

Risk of injury!

Bring the bus system into a safe, de-energized state before starting installation, disassembly or wiring of the devices!

5.2.3.1 Instructions for ESD protection

NOTICE



Devices can be destroyed by electrostatic charging!

The devices contain electrostatically sensitive components which can be damaged by improper handling.

- Please ensure you are electrostatically discharged when handling the components; also avoid touching the spring contacts directly (see illustration).
- Avoid contact with highly insulating materials (synthetic fibers, plastic films etc.)
- When handling the components, ensure good grounding of the environment (workplace, packaging and persons)
- Each bus station must be terminated on the right side with the [EL9011](#) or [EL9012](#) end cap to ensure the protection class and ESD protection.

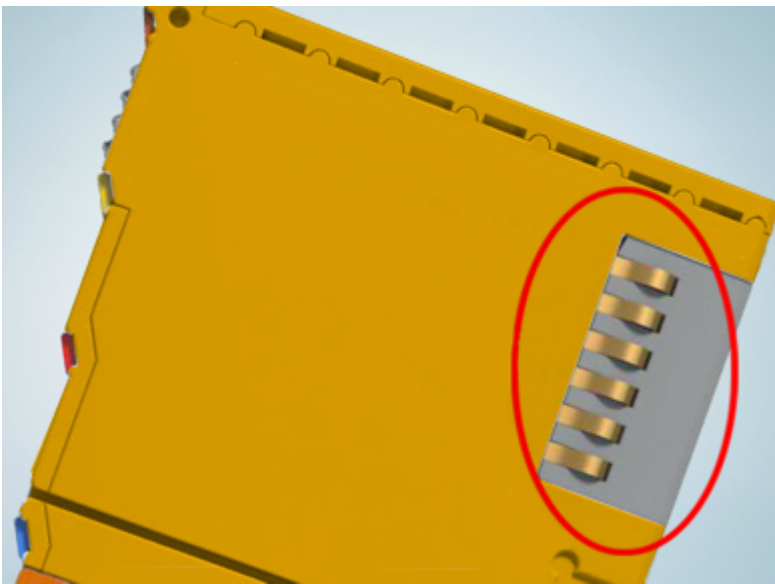

Fig. 7: Spring contacts of Beckhoff I/O components

5.2.3.2 Control cabinet / terminal box

The TwinSAFE terminals must be installed in a control cabinet or terminal box with IP54 protection class according to IEC 60529 as a minimum.

5.2.3.3 Installation position and minimum distances

For the prescribed installation position the mounting rail is installed horizontally and the mating surfaces of the EL/KL terminals point toward the front (see illustration below). The terminals are ventilated from below, which enables optimum cooling of the electronics through convection. The direction indication “down” corresponds to the direction of positive acceleration due to gravity.

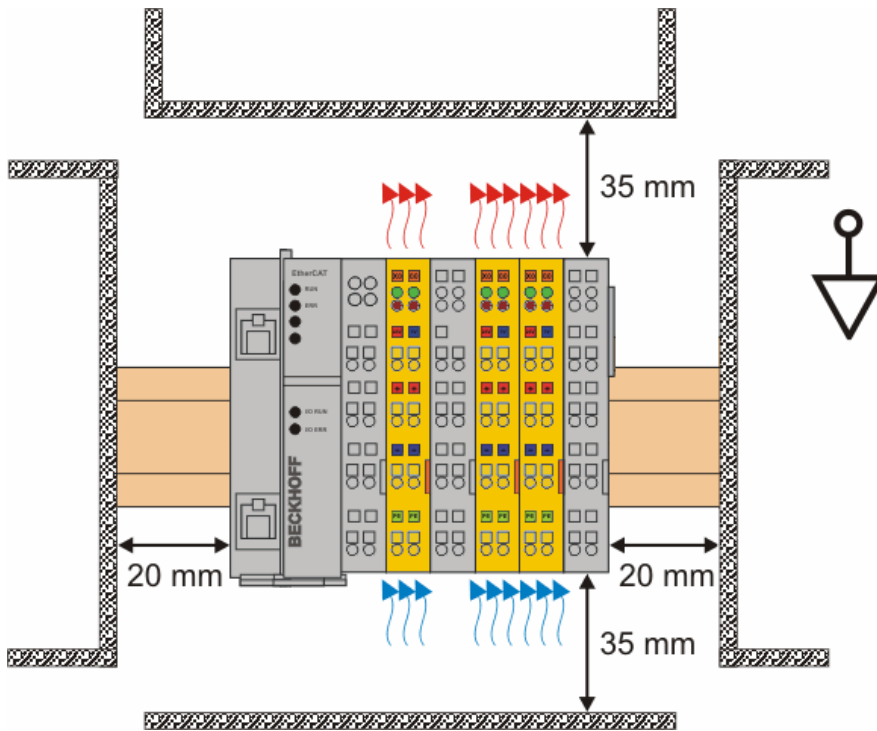

Fig. 8: Installation position and minimum distances

In order to ensure optimum convection cooling, the distances to neighboring devices and to control cabinet walls must not be smaller than those shown in the diagram.

5.2.3.4 Temperature measurement

The temperature measurement consists of an EK1100 EtherCAT Coupler, to which EtherCAT Terminals are attached, based on the typical distribution of digital and analog signal types at a machine. On the EL6910 a safety project is active, which reads safe inputs and enables safe outputs during the measurement.

NOTICE



External heat sources / radiant heat / impaired convection

The maximum permissible ambient temperature of 55°C was checked with the example configuration described above. Impaired convection, an unfavorable location near heat sources or an unfavorable configuration of the EtherCAT Terminals may result in overheating of the TwinSAFE components.

The key parameter is always the maximum permitted internally measured temperature of 110°C, above which the TwinSAFE components switch to safe state and report an error. The internal temperature can be read from the TwinSAFE components via CoE.

5.2.3.5 Notes on the arrangement of TwinSAFE components

The following notes illustrate favorable and unfavorable terminal arrangements from a thermal perspective.

Components with higher waste heat are identified with a red symbol , components with lower waste heat are identified with a blue symbol .

EK11xx EtherCAT Coupler and EL9410 power supply terminal

The more terminals are attached after an EtherCAT Coupler or a power supply terminal, the higher the E-bus current that their power supply units have to supply. With increasing current the waste heat from the power supply units also increases.

EL69x0

The EL69x0 emits a relatively high amount of waste heat, since it has a high internal clock rate and high logic performance.

EL2904, EL291x, EL291x-2200

The EL2904 emits a relatively high amount of waste heat due to the potentially high output current of the connected actuators.

EL1904

The EL1904 also emits a relatively high amount of waste heat, despite the fact that the external load due to clock outputs and safe inputs is relatively low.

Thermally unfavorable arrangement of the TwinSAFE terminals

The following arrangement is rather unfavorable, as terminals with relatively high waste heat are attached directly to the EtherCAT Coupler or the power supply terminal with high E-bus load. The additional external heating of the TwinSAFE terminals by the adjacent power supply units increases the internal terminal temperature, which can lead to the maximum permissible temperature being exceeded. This leads to the diagnosis message "Overtemperature".

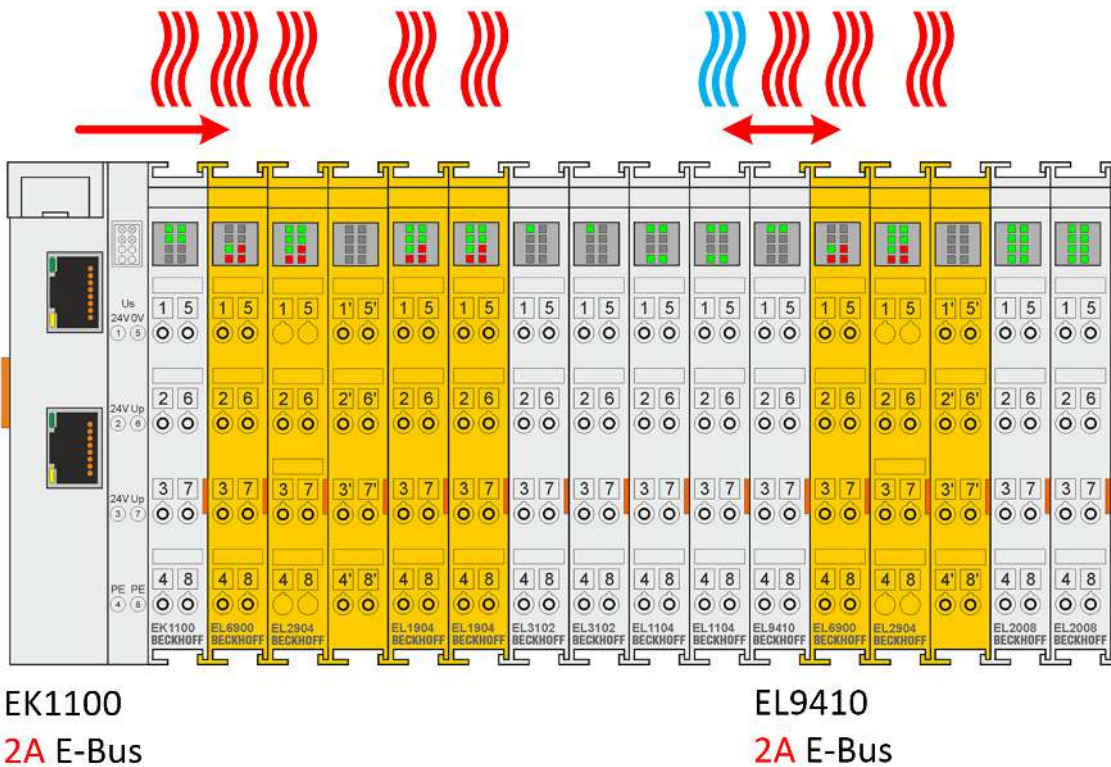

Fig. 9: Thermally unfavorable arrangement of the TwinSAFE terminals

Thermally favorable arrangement of the TwinSAFE terminals

The following arrangement is thermally optimized, as terminals with low current consumption and therefore low waste heat are attached between the EtherCAT Coupler/power supply terminal and terminals with higher waste heat.

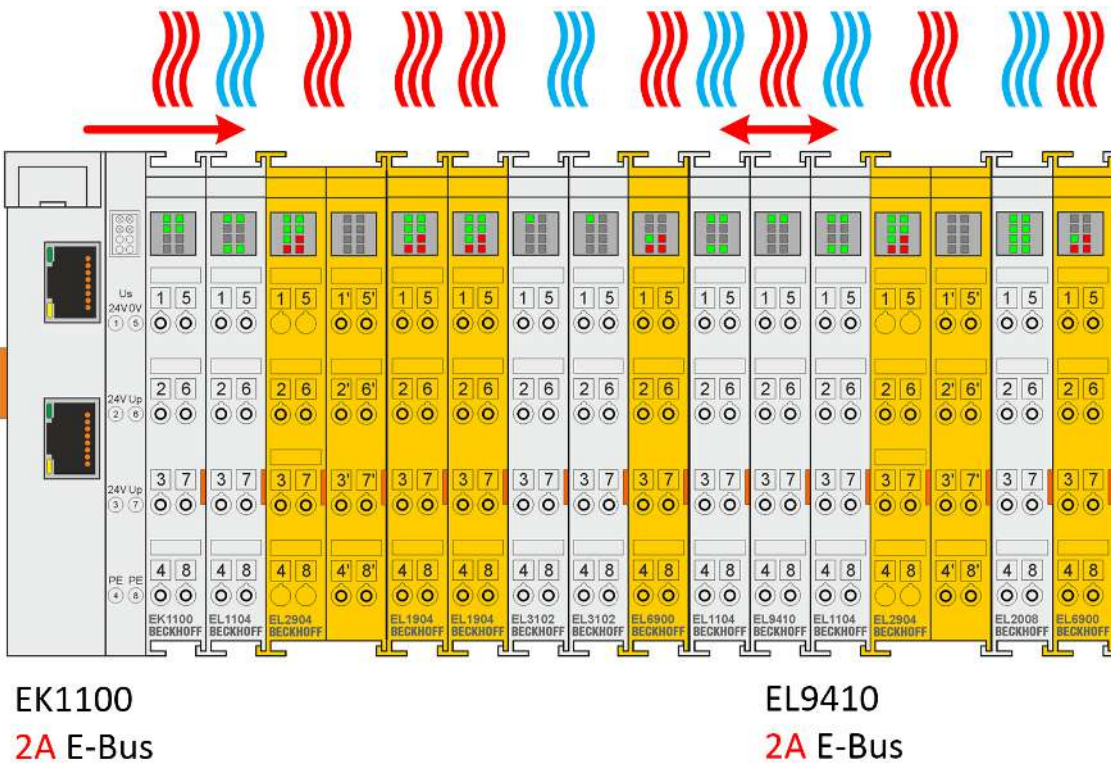

Fig. 10: Thermally favorable arrangement of the TwinSAFE terminals

5.2.3.6 Installation on mounting rails

⚠ WARNING

Risk of electric shock and damage of device!

Bring the bus terminal system into a safe, powered down state before starting installation, disassembly or wiring of the Bus Terminals!

Installation

NOTICE

Material damage due to improper installation

Pressing on the LED strip can damage the TwinSAFE component and impair the function of the LEDs.

- Do not press on the LED strip when pushing the TwinSAFE component against the mounting rail. Instead, grasp the TwinSAFE component at the top and bottom edge or at the height of the orange tab to slide it onto the mounting rail.

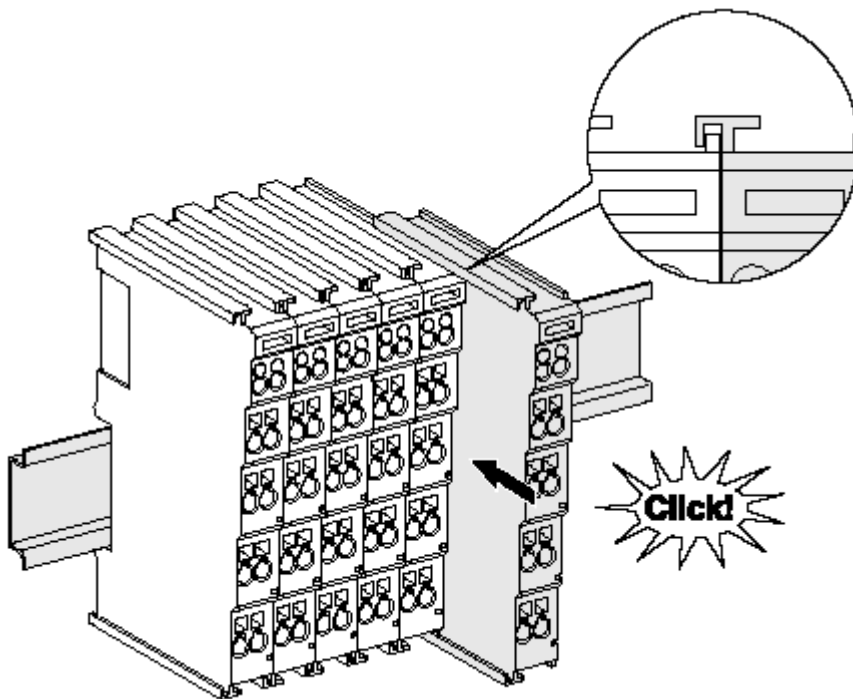

Fig. 11: Installation on the mounting rail

The bus couplers and bus terminals are attached to commercially available 35 mm mounting rails (DIN rail according to EN 60715) by applying slight pressure:

1. First attach the fieldbus coupler to the mounting rail.
2. The bus terminals are now attached on the right-hand side of the fieldbus coupler. To do this, plug the components together with tongue and groove and push the terminals against the mounting rail until the latch audibly engages on the mounting rail.

If you first snap the terminals onto the mounting rail and then push them next to each other without the tongue and groove interlocking, no functional connection will be established! When correctly assembled, no significant gap should be visible between the housings.

● Fastening of mounting rails

i The locking mechanism of the terminals and couplers protrudes into the profile of the mounting rail. When installing the components, make sure that the locking mechanism doesn't come into conflict with the fixing bolts of the mounting rail. For fastening mounting rails with a height of 7.5 mm under the terminals and couplers, use flat fastening components such as countersunk head screws or blind rivets.

Disassembly

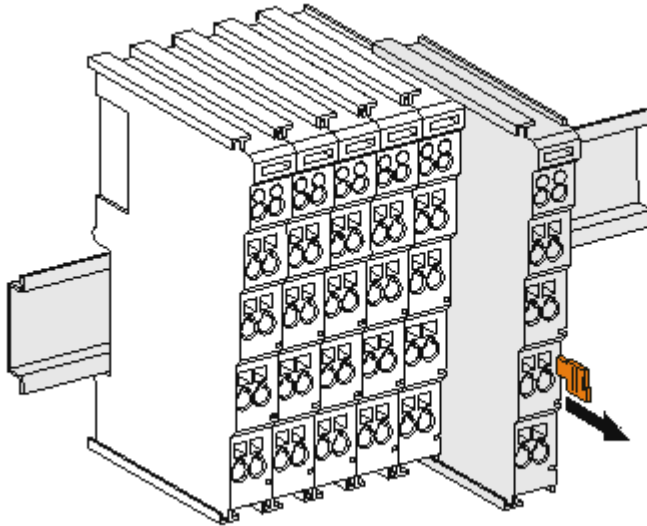

Fig. 12: Removal from mounting rail

Each terminal is secured by a lock on the mounting rail, which must be released for disassembly:

1. Pull down the terminal at its orange-colored straps from the mounting rail by approx. 1 cm. The rail locking of this terminal is automatically released, and you can now pull the terminal out of the Bus Terminal block with little effort.
2. To do this, grasp the unlocked terminal simultaneously at the top and bottom of the housing surfaces with your thumb and index finger and pull it out of the Bus Terminal block.

5.2.4 Electrical installation

5.2.4.1 Connections within a Bus Terminal block

The electric connections between the Bus Coupler and the Bus Terminals are automatically realized by joining the components:

Spring contacts (E-bus)

The six spring contacts of the E-bus deal with the transfer of the data and the supply of the Bus Terminal electronics.

NOTICE

Observe the E-bus current

Observe the maximum current that your Bus Coupler can supply to the E-bus! Use the EL9410 Power Supply Terminal if the current consumption of your terminals exceeds the maximum current that your Bus Coupler can feed to the E-bus supply.

Power contacts

The power contacts deal with the supply for the field electronics and thus represent a supply rail within the Bus Terminal block. The power contacts are supplied via terminals on the Bus Coupler.

● Note the connection of the power contacts

i During the design of a Bus Terminal block, the pin assignment of the individual Bus Terminals must be taken account of, since some types (e.g. analog Bus Terminals or digital 4-channel Bus Terminals) do not or not fully loop through the power contacts. Potential supply terminals (EL91xx, EL92xx) interrupt the power contacts and thus represent the start of a new supply rail.

PE power contact

The power contact labelled PE can be used as a protective earth. For safety reasons this contact mates first when plugging together, and can ground short-circuit currents of up to 125 A.

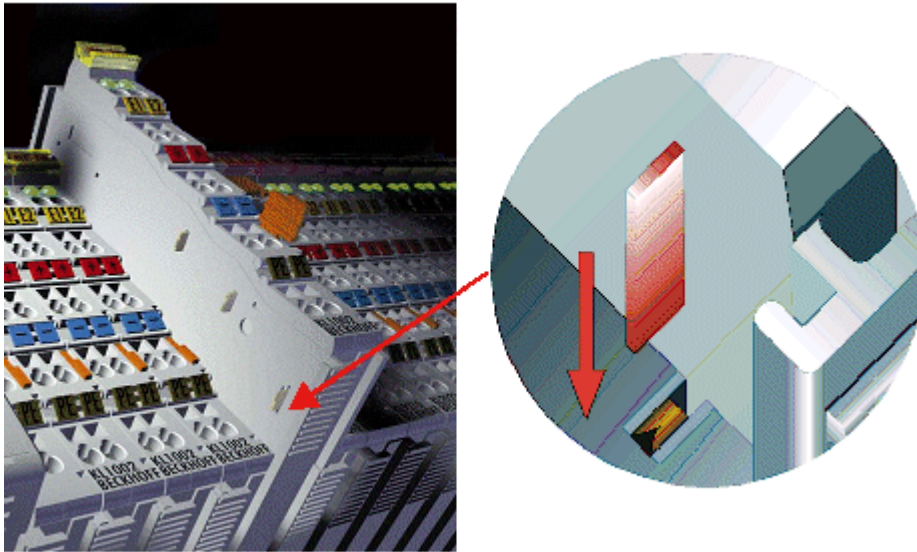

Fig. 13: PE power contact

⚠ CAUTION

Insulation tests

Note that, for reasons of electromagnetic compatibility, the PE contacts are capacitatively coupled to the mounting rail. This may lead to incorrect results during insulation testing or to damage on the terminal (e.g. disruptive discharge to the PE line during insulation testing of a consumer with a rated voltage of 230 V). For insulation testing, disconnect the PE supply line at the Bus Coupler or the Potential Supply Terminal! In order to decouple further feed points for testing, these Power Feed Terminals can be released and pulled at least 10 mm from the group of terminals.

⚠ DANGER

Serious risk of injury!

The PE power contact must not be used for other potentials!

5.2.4.2 Overvoltage protection

If protection against overvoltage is necessary in your plant, provide a surge filter for the voltage supply to the Bus Terminal blocks and the TwinSAFE terminals.

5.2.4.3 HD housing wiring

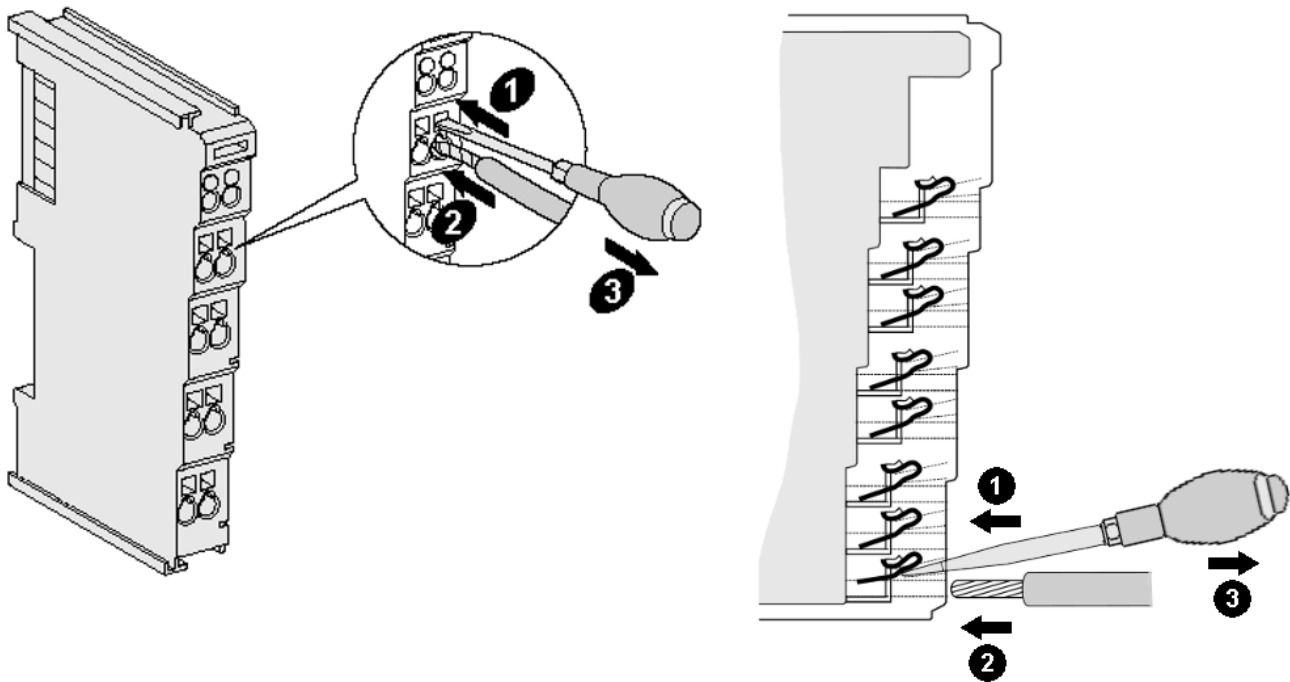

Fig. 14: Connection of a cable to a terminal point

Up to 16 terminal points enable the connection of solid or finely stranded wires to the EtherCAT Terminal. The terminal points are spring-loaded.

● Several conductors at one connection

i If it is necessary to connect several conductors to one connection, pre-connect them with terminal blocks, for example.

Solid and stranded wire conductors with ferrules can be inserted directly into the terminal point. This eliminates steps 1 and 3 in the above illustration. For all other conductor types, the terminal point must be opened with a screwdriver to establish the connection.

Connect the cables as follows:

1. Open a terminal point by pushing a screwdriver straight into the square opening above the terminal point as far as it will go. Do not turn or move the screwdriver back and forth (do not lever)
2. The wire can now be inserted into the round terminal opening without any force.
3. The terminal closes automatically when the pressure is released, holding the wire safely and permanently.

The permissible conductor cross-sections can be taken from the following table.

Wire cross-section (solid)	0.08 ... 1.5 mm ²
Wire cross-section (stranded wire)	0.25 ... 1.5 mm ²
Wire cross-section (core wire with ferrule)	0.14 ... 0.75 mm ²
Strip length	8 ... 9 mm

5.2.4.4 Connection

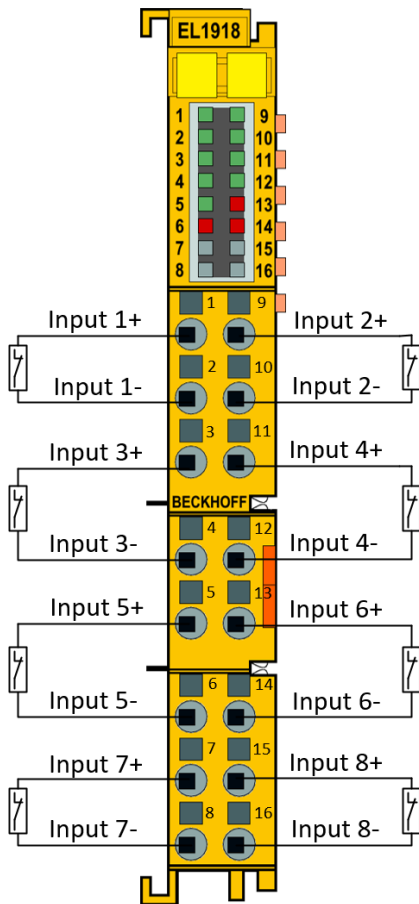

Fig. 15: EL1918 connection

Terminal point	Input	Signal
1	1	Input 1+ (clock output)
2		Input 1- (safe input)
3	3	Input 3+ (clock output)
4		Input 3- (safe input)
5	5	Input 5+ (clock output)
6		Input 5- (safe input)
7	7	Input 7+ (clock output)
8		Input 7- (safe input)
9	2	Input 2+ (clock output)
10		Input 2- (safe input)
11	4	Input 4+ (clock output)
12		Input 4- (safe input)
13	6	Input 6+ (clock output)
14		Input 6- (safe input)
15	8	Input 8+ (clock output)
16		Input 8- (safe input)

Configurable inputs

The inputs 1 to 8 can be occupied as you want with normally closed contacts or normally open contacts. The corresponding analysis is carried out in the safety PLC. The input labeled *Input x-* is used for connecting OSSD sensors (self-testing sensors).

5.2.4.5 Signal cables

Cable routing

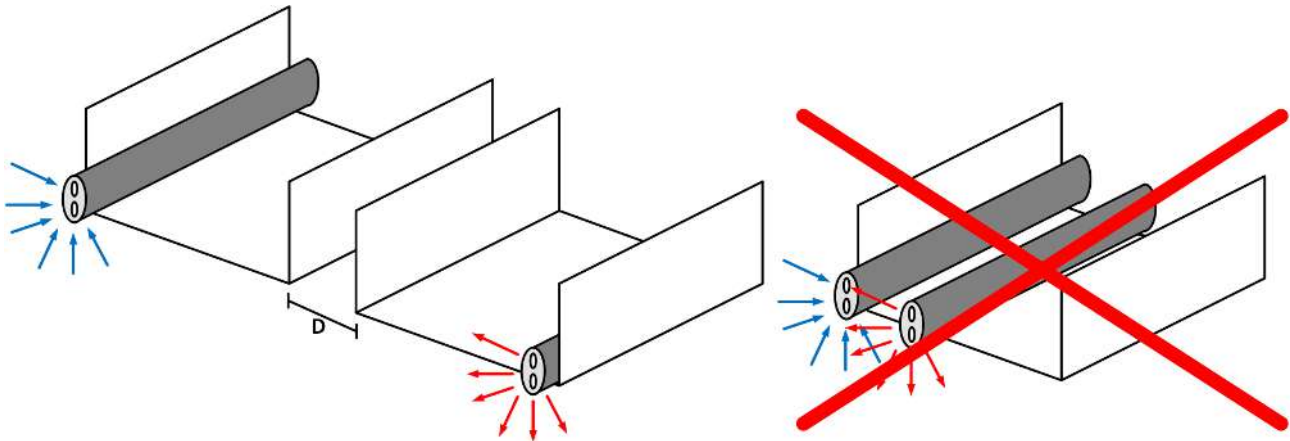

Fig. 16: Cable routing

NOTICE

Route the signal cable separately

The signal cable must be routed separately from potential sources of interference, such as motor supply cables, 230 V_{AC} power cables etc.!

Interference caused by cables routed in parallel can influence the signal form of the test pulses and thus cause diagnostic messages (e.g. sensor errors or OpenLoad errors).

D: Distance between the cable ducts should be as large as possible

blue arrows: signal line

red arrows: potential source of interference

The common routing of signals together with other clocked signals in a common cable also reduces the maximum propagation, since crosstalk of the signals can occur over long cable lengths and cause diagnostic messages.

5.3 Configuration of the terminal in TwinCAT



Identical configuration

The configuration of the terminal in TwinCAT is identical for the EL1918-2200 variant.

⚠ CAUTION

Do not change CoE objects!

Do not change any of the CoE objects in the TwinSAFE terminals. Any modifications (e.g. via TwinCAT) of the CoE objects will permanently set the terminals to the Fail-Stop state or lead to unexpected behavior of the terminals!

5.3.1 Inserting a Bus Coupler

See TwinCAT automation software documentation.

5.3.2 Inserting a Bus Terminal

See TwinCAT automation software documentation.

5.3.3 Adding an EL1918

An EL1918 is added in exactly the same way as any other Beckhoff EtherCAT Terminal. Open *TwinSAFE Terminals* item in the list and select the EL1918.

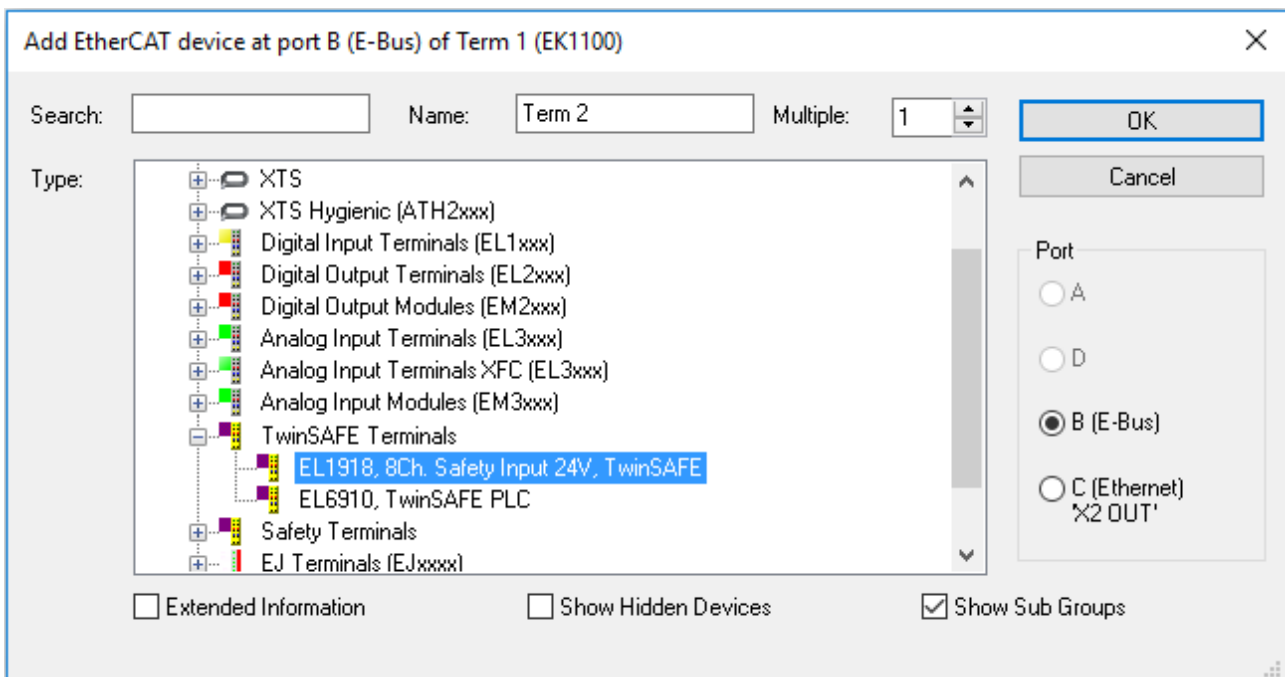

Fig. 17: Adding an EL1918

5.3.4 Address settings on TwinSAFE terminals with 1023 possible addresses

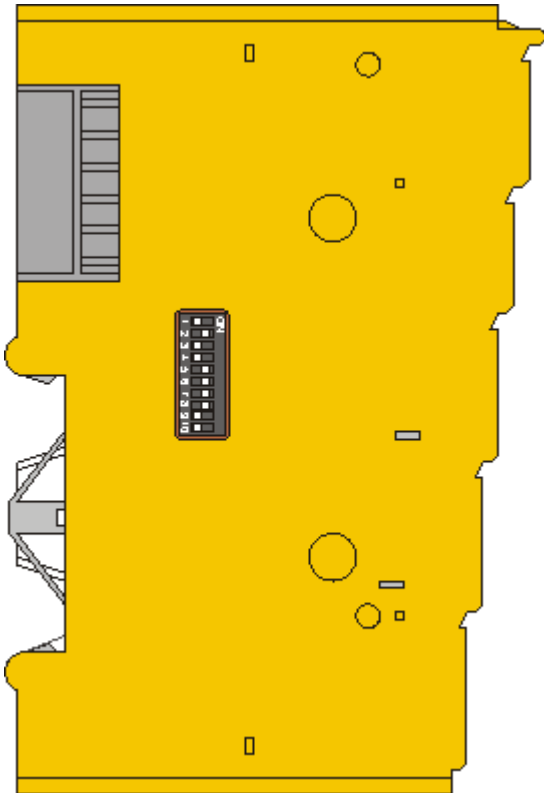

Fig. 18: Address settings on TwinSAFE terminals with 1023 possible addresses

The TwinSAFE address of the terminal is set via the 10-way DIP switch on the left-hand side of the TwinSAFE terminal. TwinSAFE addresses between 1 and 1023 are available.

DIP switch										Address
1	2	3	4	5	6	7	8	9	10	
ON	OFF	OFF	OFF	OFF	OFF	OFF	OFF	OFF	OFF	1
OFF	ON	OFF	OFF	OFF	OFF	OFF	OFF	OFF	OFF	2
ON	ON	OFF	OFF	OFF	OFF	OFF	OFF	OFF	OFF	3
OFF	OFF	ON	OFF	OFF	OFF	OFF	OFF	OFF	OFF	4
ON	OFF	ON	OFF	OFF	OFF	OFF	OFF	OFF	OFF	5
OFF	ON	ON	OFF	OFF	OFF	OFF	OFF	OFF	OFF	6
ON	ON	ON	OFF	OFF	OFF	OFF	OFF	OFF	OFF	7
...
ON	ON	ON	ON	ON	ON	ON	ON	ON	ON	1023

⚠ WARNING

TwinSAFE address

Each TwinSAFE address may only be used once within a network / a configuration!
The address 0 is not a valid TwinSAFE address!

5.3.5 Alias devices

The communication between the safety logic and the I/O level is realized via an alias level. At this alias level (sub-node *Alias Devices*) corresponding alias devices are created for all safe inputs and outputs, and also for standard signal types. For the safe inputs and outputs, this can be done automatically via the I/O configuration.

The connection- and device-specific parameters are set via the alias devices.

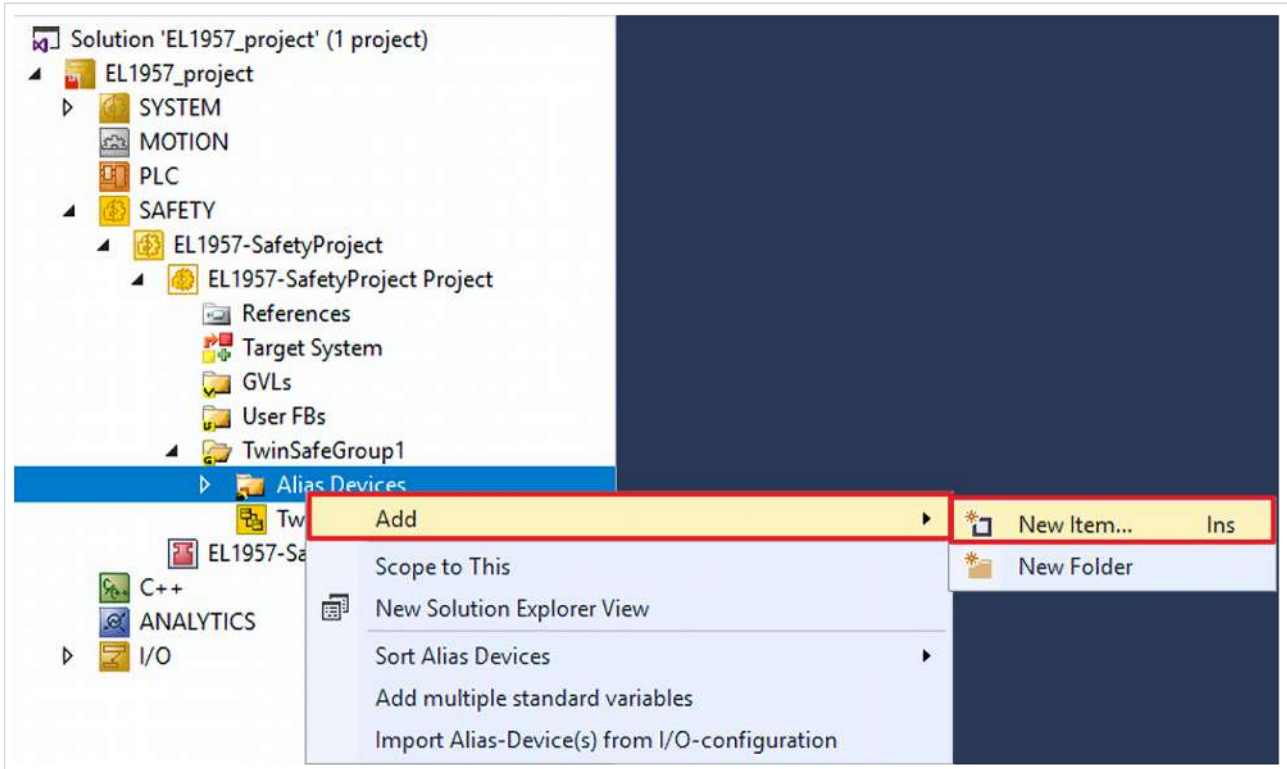

If the automatic import is started from the I/O configuration, a selection dialog opens, in which the individual terminals to be imported can be selected.

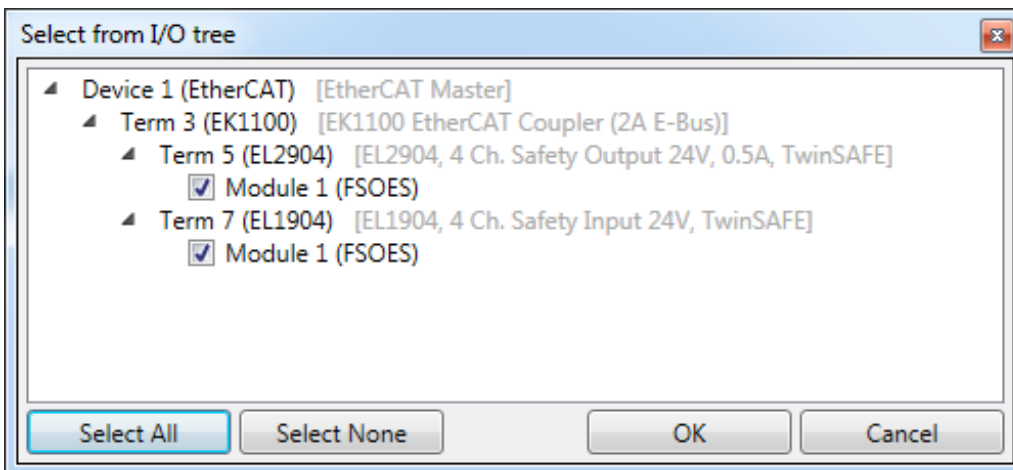

Fig. 19: Selection from the I/O tree

The alias devices are created in the safety project when the dialog is closed via OK.

Alternatively, the user can create the alias devices individually. To this end select *Add* and *New item* from the context menu, followed by the required device.

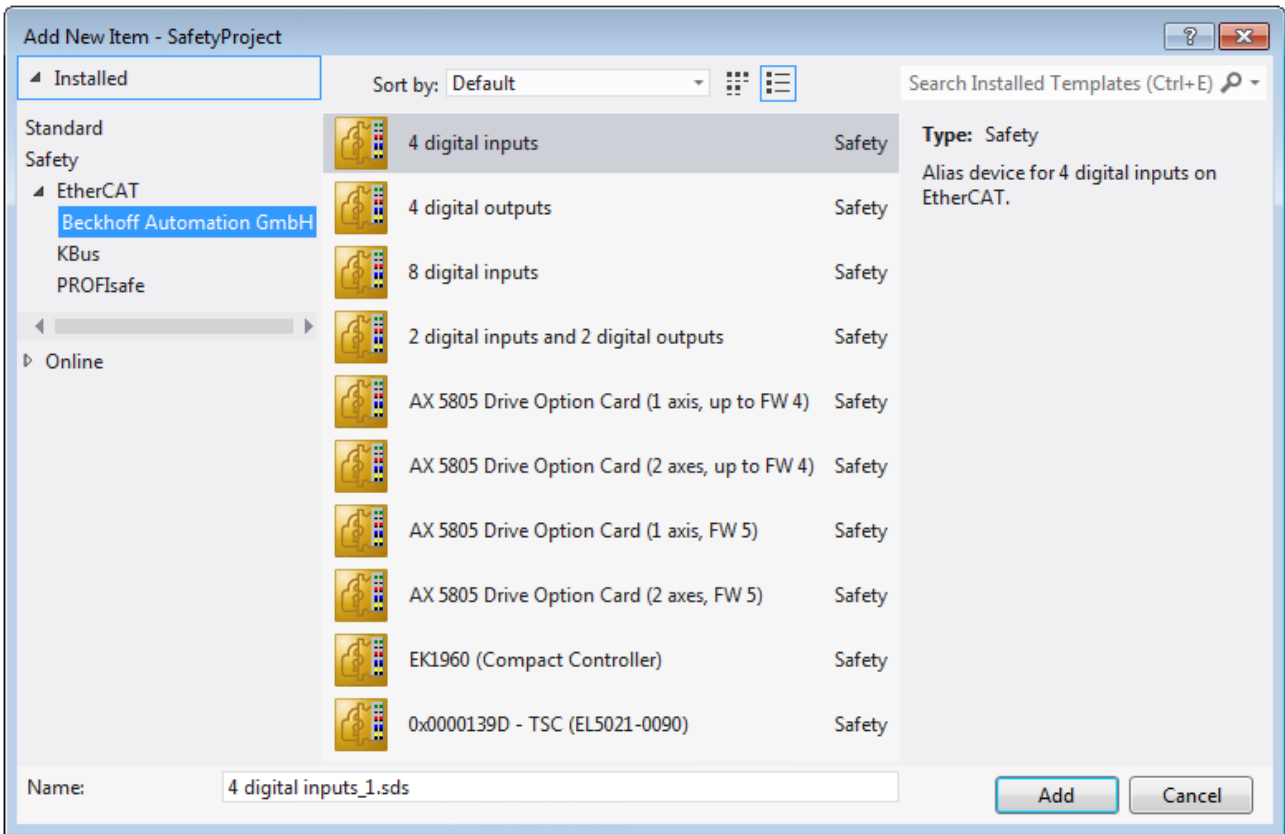

Fig. 20: Creating alias devices by the user

5.3.6 EL1918 parameters in TwinCAT

After creating the alias device, it can be parameterized according to the user specifications.

The FSoE address is set under the *Linking* tab, and the link to the physical device is created.

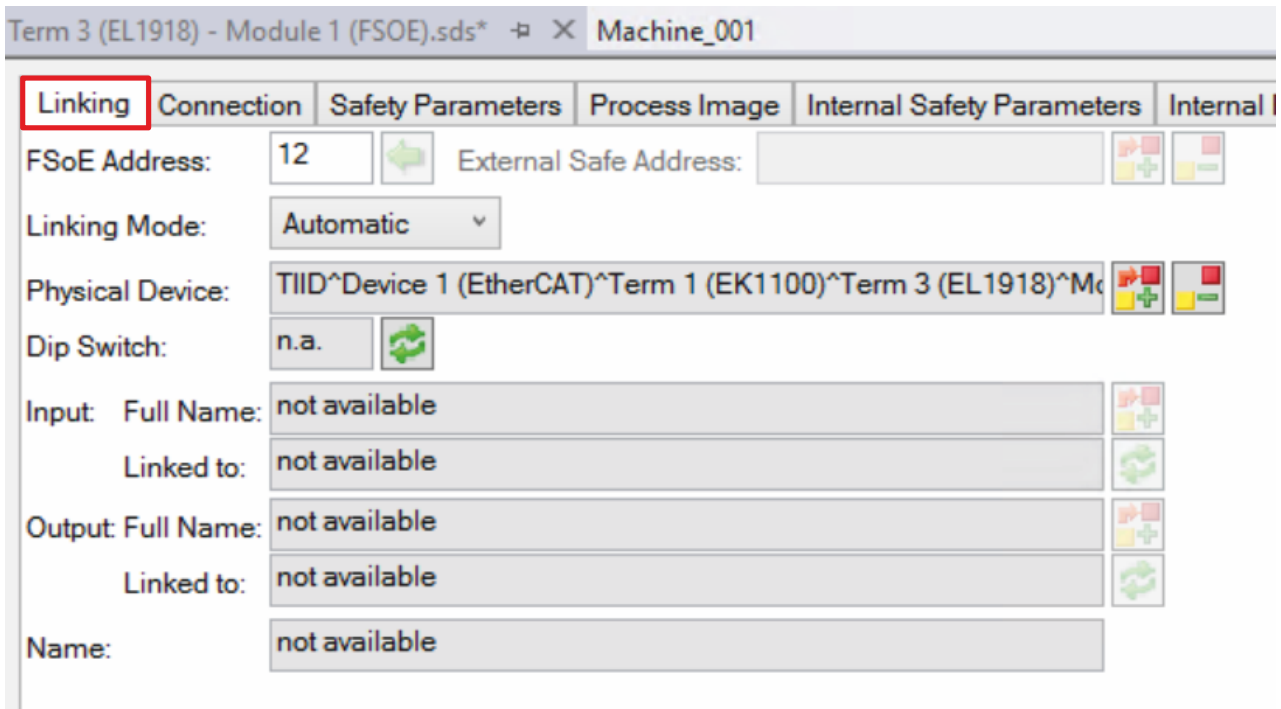

Fig. 21: Linking tab of the alias device

Under the *Connection* tab you can make further settings, e.g. the mapping of the info data or the behavior in case of a module error.

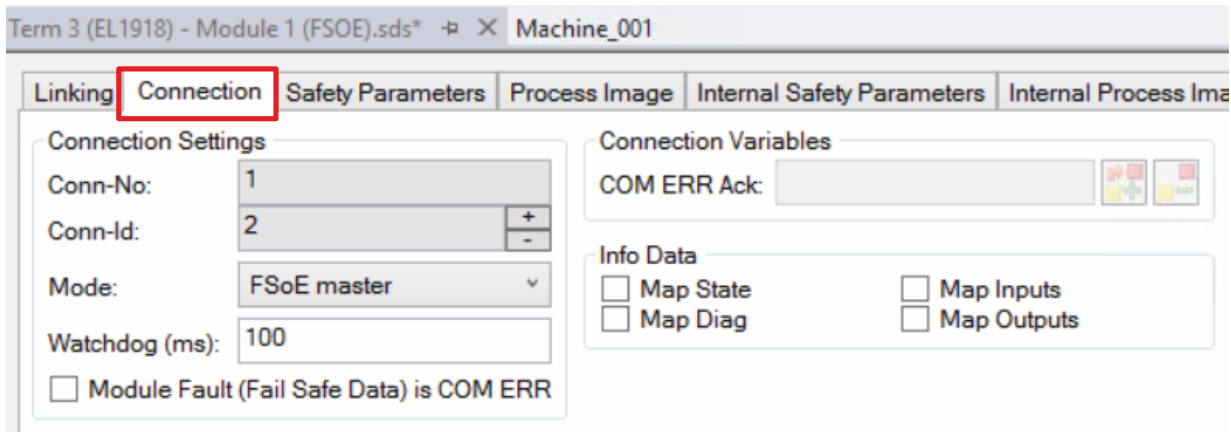

Fig. 22: Connection tab of the alias device

The *Safety Parameters* tab contains the parameters of the EL1918 to be set. The parameters are set separately for each input. Objects 0x8000 and 0x8001 are available for input 1. For all other inputs, the CoE index is increased by 10 hex each, so that objects 0x8070 and 0x8071 are available for input 8.

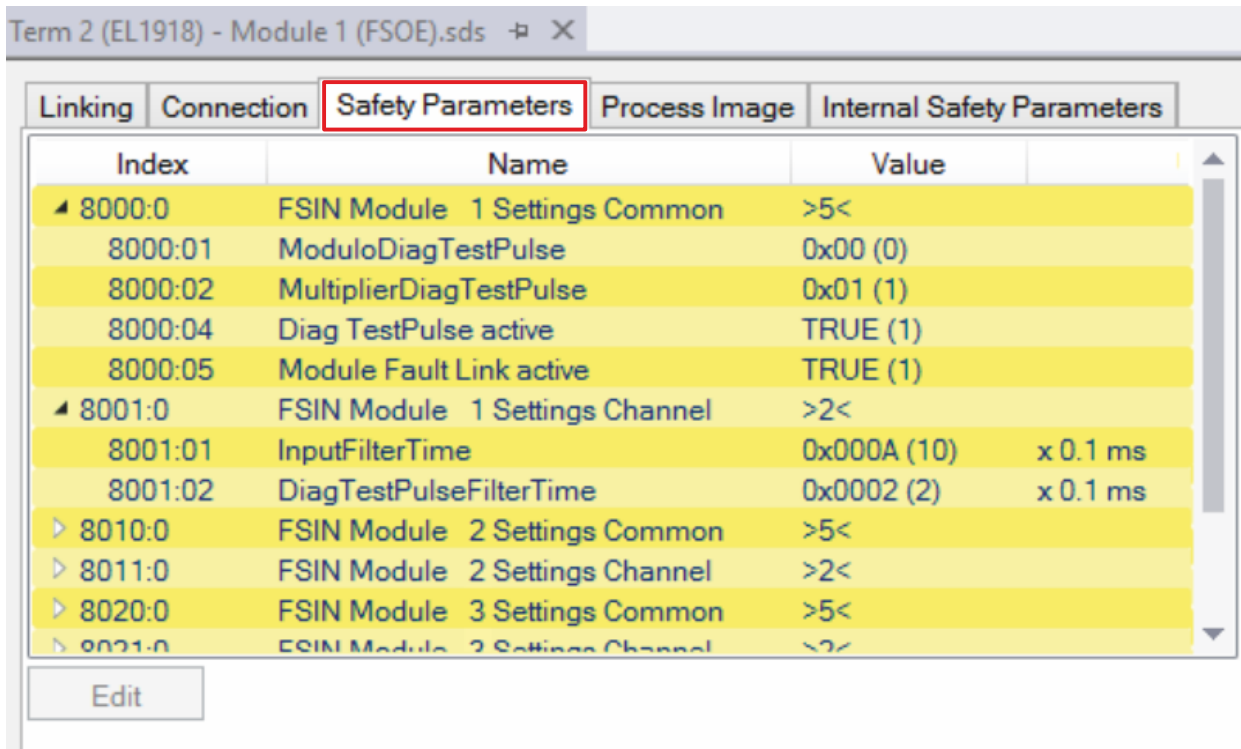

Fig. 23: EL1918 parameters

Index	Name	Default value/ unit	Description
80x0:01	ModuloDiagTestPulse	0x00 / integer	Modulo value for the frequency of generating a test pulse. 0 -> every time 1 -> every second time ...
80x0:02	MultiplierDiagTestPulse	0x01 / integer	Length of the test pulse in multiples of 400 µs

Index	Name	Default value/ unit	Description
80x0:04	Diag TestPulse active	TRUE / Boolean	Activation of test pulses for the corresponding input module
80x0:05	Module Fault Link active	TRUE / Boolean	If a module error occurs in this module, a module error is also set for all other modules of this TwinSAFE component for which this parameter is also set to TRUE.
80x1:01	InputFilterTime	0x000A / 0.1 ms	Input filter of the safe input. Following this time the internal input signal changes to the applied signal state.
80x1:02	DiagTestPulseFilterTime	0x0002 / 0.1 ms	Input filter for the test pulse signal

5.3.7 Process image of the EL1918

The process image of the EL1918 consists of 7 bytes process data in the input and 6 bytes process data in the output.

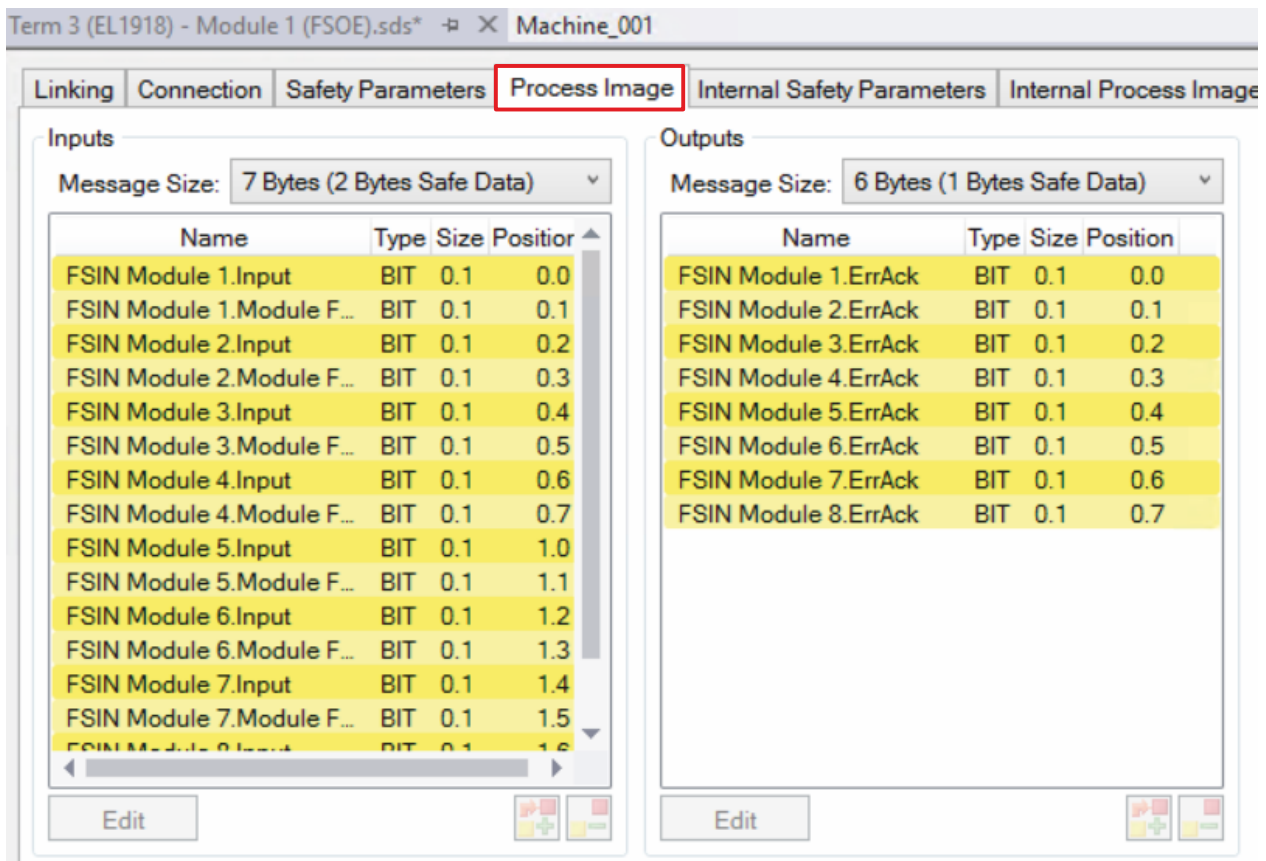

Fig. 24: Process image of the EL1918

The assignment of the individual signals in the safe data is listed in the following table.

Name	Process image	Bit position	Description
FSIN Module1.Input	IN	0.0	Safe input 1
FSIN Module1.Module Fault	IN	0.1	Module error information for input 1
FSIN Module2.Input	IN	0.2	Safe input 2
FSIN Module2.Module Fault	IN	0.3	Module error information for input 2
FSIN Module3.Input	IN	0.4	Safe input 3
FSIN Module3.Module Fault	IN	0.5	Module error information for input 3

Name	Process image	Bit position	Description
FSIN Module4.Input	IN	0.6	Safe input 4
FSIN Module4.Module Fault	IN	0.7	Module error information for input 4
FSIN Module5.Input	IN	1.0	Safe input 5
FSIN Module5.Module Fault	IN	1.1	Module error information for input 5
FSIN Module6.Input	IN	1.2	Safe input 6
FSIN Module6.Module Fault	IN	1.3	Module error information for input 6
FSIN Module7.Input	IN	1.4	Safe input 7
FSIN Module7.Module Fault	IN	1.5	Module error information for input 7
FSIN Module8.Input	IN	1.6	Safe input 8
FSIN Module8.Module Fault	IN	1.7	Module error information for input 8
FSIN Module 1.ErrAck	OUT	0.0	Error acknowledge for safe input 1
FSIN Module 2.ErrAck	OUT	0.1	Error acknowledge for safe input 2
FSIN Module 3.ErrAck	OUT	0.2	Error acknowledge for safe input 3
FSIN Module 4.ErrAck	OUT	0.3	Error acknowledge for safe input 4
FSIN Module 5.ErrAck	OUT	0.4	Error acknowledge for safe input 5
FSIN Module 6.ErrAck	OUT	0.5	Error acknowledge for safe input 6
FSIN Module 7.ErrAck	OUT	0.6	Error acknowledge for safe input 7
FSIN Module 8.ErrAck	OUT	0.7	Error acknowledge for safe input 8

5.3.8 EL1918: using the integrated TwinSAFE Logic functions

In addition to its standard function as a digital safe input terminal, the EL1918 TwinSAFE Terminal also supports the option of executing a local safety-related user program. To do this, select the EL1918 as the target system in the TwinCAT Safety Editor.

Information on creating a safety user program can be found in the documentation for the EL6910 (see References).

The default project, so that the EL1918 once again behaves as a safe input terminal, can be reactivated by deleting the safety-related user program from the TwinSAFE component. To do this, select the entry *Safe Logic, Mapping and Parameter Data* in the dialog for deleting the project. After switching the TwinSAFE component off and on, the default project is active again.

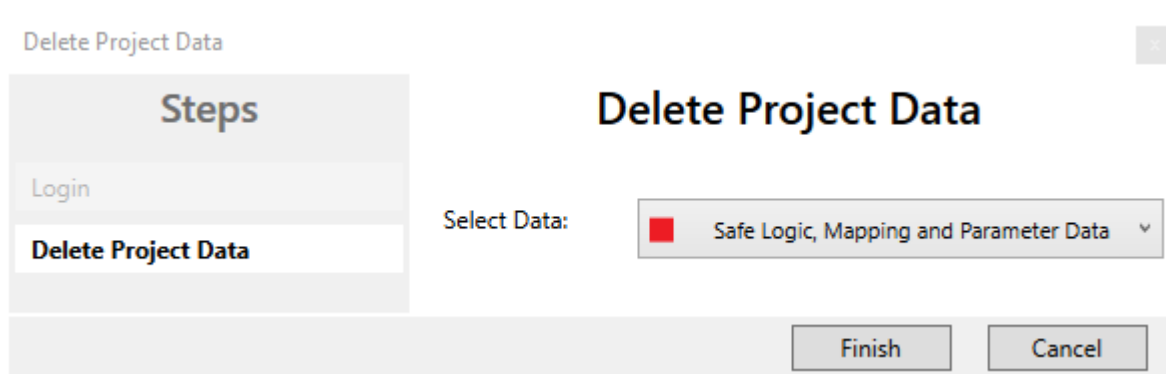

Fig. 25: Deleting the project data

5.3.8.1 Project design limits of EL1918

● Project design limits

I The maximum project design size for EL1918 is determined by the available memory. This is managed dynamically. The values specified in the following table are therefore only guide values and may differ from the actual values, depending on the safety project.

NOTICE

Execution time of the logic function
 The execution time of the logic program - with identical logic program - will typically be longer compared to the EL6910, since the safe I/O signals must be processed additionally. This also has a corresponding effect on the processing of the I/O signals, since with increasing project size these can only be evaluated with a lower frequency.

Process image size	max. 1486 byte per data direction (maximum memory size 0x1E00 for 3 buffers, ie with the same size of input and output process data, a maximum size of 1280 bytes per data direction is possible. Only straight start addresses are possible, so fill bytes must be taken into account)
TwinSAFE connections	128 max. (up to 255 CRCs in total; 1 CRC is required for a TwinSAFE connection with 1 or 2 byte safe data.)
Safe data per TwinSAFE connection	maximum 126 byte (telegram length 255 byte)
TwinSAFE blocks	maximum 512 (when using ESTOP function blocks with complete input and output mapping, other function blocks can lead to a smaller maximum number)
TwinSAFE groups	128 max.
TwinSAFE user	40 max.
Standard PLC inputs	dynamic (memory-dependent), max. 1484 byte
Standard PLC outputs	dynamic (memory-dependent), max. 1484 byte

NOTICE

Project development
 TwinCAT 3.1 Build 4022.25 or newer is required to use the internal logic functions. If the EL1918 is used as TwinSAFE slave with the default project, at least an EL6910, EK1960 or newer logic component is required as TwinSAFE master.

5.4 TwinSAFE reaction times

5.4.1 Typical response time

The typical reaction time is the time that is required to transmit information from the sensor to the actuator, if the overall system is working without error in normal operation.

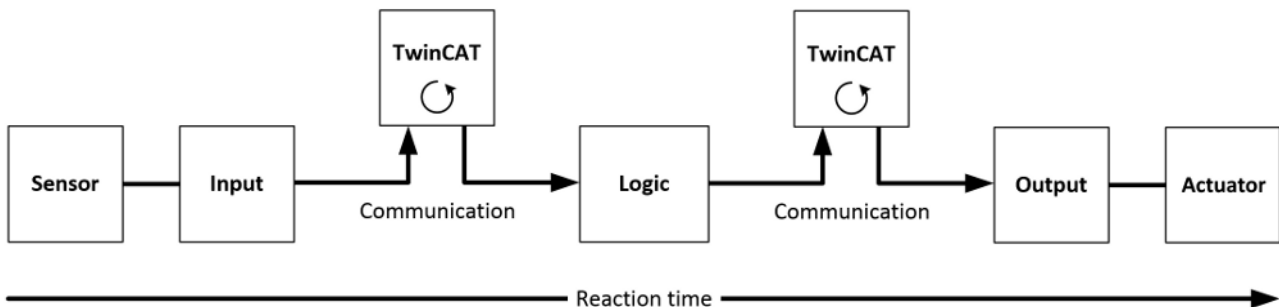

Fig. 26: Typical response time

Definition	Description
RTSensor	Response time of the sensor, until the signal is made available at the interface. Typically provided by the sensor manufacturer.

Definition	Description
RTInput	Response time of the safe input, e.g. EL1904 or EP1908. This time can be found in the technical data. In the case of the EL1904 it is 4 ms.
RTComm	Response time of the communication. This is typically 3 times the EtherCAT cycle time, since a new Safety-over-EtherCAT telegram has to be generated before new data can be sent. These times depend directly on the higher-level standard controller (cycle time of the PLC/NC).
RTLogic	Response time of the logic terminal. This is the cycle time of the logic terminal and typically ranges from 500 µs to 10 ms for the TwinSAFE logic terminal, depending on the size of the safety project. The actual cycle time can be read from the terminal.
RTOutput	Response time of the output terminal. This is typically between 2 and 3 ms.
RTActor	Response time of the actuator. This information is typically provided by the actuator manufacturer
WDComm	Watchdog time of the communication

The typical response time is based on the following formula:

$$ReactionTime_{typ} = RT_{Sensor} + RT_{Input} + 3 * RT_{Comm} + RT_{Logic} + 3 * RT_{Comm} + RT_{Output} + RT_{Actuator}$$

with

$$ReactionTime_{typ} = 5\text{ ms} + 4\text{ ms} + 3 * 1\text{ ms} + 10\text{ ms} + 3 * 1\text{ ms} + 3\text{ ms} + 20\text{ ms} = 48\text{ ms}$$

5.4.2 Worst case response time

The worst-case response time is the maximum time required for switching off the actuator in the event of an error.

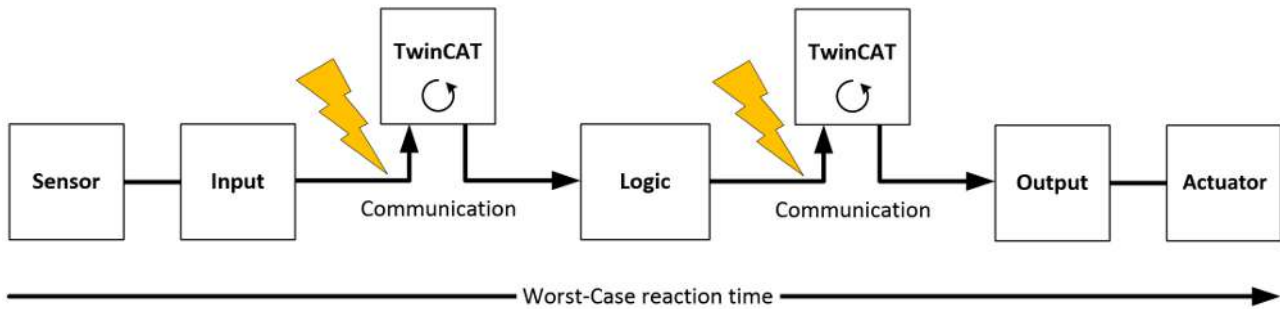

Fig. 27: Worst case response time

It is assumed that a signal change takes place at the sensor, and that this is passed to the input. A communication error occurs just at the moment when the signal is to be passed to the communication interface. This is detected by the logic once the watchdog time of the communication connection has elapsed. This information should then be passed on to the output, resulting in a further communication error. This fault is detected at the output once the watchdog time has elapsed, resulting in shutdown.

This results in the following formula for the worst-case response time:

$$ReactionTime_{max} = WD_{Comm} + WD_{Comm} + RT_{Actuator}$$

with

$$ReactionTime_{max} = 15\text{ ms} + 15\text{ ms} + 20\text{ ms} = 50\text{ ms}$$

5.5 Diagnosis

5.5.1 Status LEDs

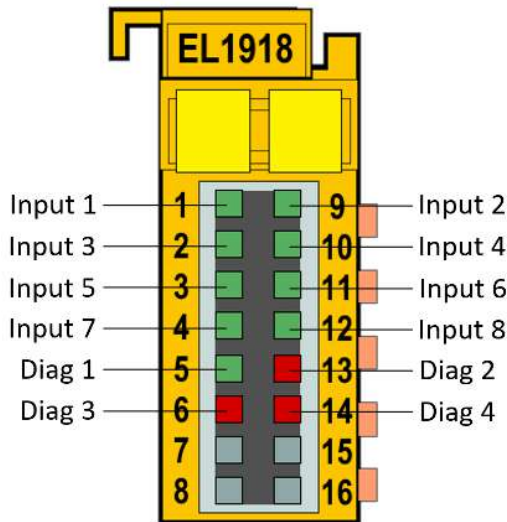

Fig. 28: Status LEDs

LED	Color	Description
Input 1	green	Status display for the respective input LED lights up: Input is set LED not lit: Input is not set
Input 2		
Input 3		
Input 4		
Input 5		
Input 6		
Input 7		
Input 8		

5.5.2 Diagnostic LEDs

Diagnostic LEDs

LED	lit	flashing	off
Diag 1 (green)	Environment variables, operating voltage and internal tests are in the valid range • If Diag 2 flashes, a logic error code applies	-	Environment variables, operating voltage and internal tests are outside the valid range • If Diag 2 flashes, an environment error code applies
Diag 2 (red)	Together with Diag 3 and 4: Global shutdown ¹⁾ has occurred. (see diag history of the TwinSAFE components)	Logic or environment error code according to Diag1 and tables below is output	Together with Diag 3 and 4: Global fault ¹⁾ has occurred. (see diag history of the TwinSAFE components)
Diag 3 (red)	Global fault or global shutdown on $\mu C1^{1)}$	-	No global fault or global shutdown on $\mu C1^{1)}$
Diag 4 (red)	Global fault or global shutdown on $\mu C2^{1)}$	-	No global fault or global shutdown on $\mu C2^{1)}$

1. A global fault permanently disables the TwinSAFE component, so that it has to be replaced. A global shutdown temporarily disables the TwinSAFE component. The error can be reset by switching off and back on again.



Logic error codes of LED Diag 2 (if LED Diag 1 is lit)

Flashing Code	Description
1	Function block error in one of the TwinSAFE groups
2	Communication error in one of the TwinSAFE groups
3	Error combination: Function block and communication
4	General error in one of the TwinSAFE groups
5	Error combination: General and function block
6	Error combination: General and communication
7	Error combination: General, function block and communication

Environment error codes of LED Diag 2 (if LED Diag 1 is off)

Flashing Code	Description
1	Maximum supply voltage μC1 exceeded
2	Supply voltage μC1 below minimum value
3	Maximum supply voltage μC2 exceeded
4	Supply voltage μC2 below minimum value
5	Maximum internal temperature exceeded
6	Internal temperature below minimum value
7	Valid temperature difference between μC1 and μC2 exceeded
8	not used
9	not used
10	General error

5.5.3 Flash code display

LED	Display	Description
flashing		400 ms ON / 400 ms OFF 1 second pause between the flash codes
flickering		50 ms ON / 50 ms OFF

5.5.4 Diagnosis History

The diagnostic history of the TwinSAFE devices that support this function is implemented in accordance with the ETG guideline ETG.1020 Chapter 13 "Diagnosis Handling". The diagnostic messages are saved by the TwinSAFE device in a dedicated CoE object under 0x10F3 and can be read out by the application or by TwinCAT.

Both the control entries and the history itself can be found in the CoE object 0x10F3. The entry Newest Message (0x10F3:02) contains the subindex of 0x10F3, which contains the latest diagnostic message, e.g. 0x06 for diagnostic message 1.

Index 10F3_{hex} Diagnosis History

Index (hex)	Name	Meaning	Data type	Flags	Default
10F3:0	Diagnosis History				

Index (hex)	Name	Meaning	Data type	Flags	Default
10F3:01	Maximum Messages	Maximum number of stored messages. A maximum of 64 messages can be stored. After that the respective oldest messages are overwritten.	UINT8	RO	0x40 (64 _{dec})
10F3:02	Newest Message	Subindex of the latest message	UINT8	RO	0x00 (0 _{dec})
10F3:03	Newest Acknowledged Message	Subindex of the last confirmed message	UINT8	RW	0x00 (0 _{dec})
10F3:04	New Messages Available	Indicates that a new message is available	BOOLEAN	RO	0x00 (0 _{dec})
10F3:05	Flags	Set via the startup list. If set to 0x0001, the diagnostic messages are additionally sent by emergency to the EtherCAT master	UINT16	RW	0x0000 (0 _{dec})
10F3:06	Diagnosis Message 001	Diagnostic message 1	BYTE[32]	RO	{0}
...
10F3:45	Diagnosis Message 064	Diagnostic message 64	BYTE[32]	RO	{0}

Structure of the diagnostic messages

- DiagCode (4 bytes) – in this case always 0x 0000 E000
- Flags (2 bytes) - diagnosis type (info, warning or error), timestamp and number of parameters contained (see the following table)
- Text ID (2 bytes) – ID of the diagnostic message as a reference to the message text from the ESI/XML
- Timestamp (8 bytes) – local slave time in ns since switching on the TwinSAFE device
- dynamic parameters (16 bytes) – parameters that can be inserted in the message text (see following table)

Flags in diagnostic messages

Data type	Offset	Description	
UINT16	Bits 0 to 3	DiagType (value)	
		0	Info message
		1	Warning message
		2	Error message
	3...15	reserved	
	Bit 4	If the bit = 1, the timestamp contained in the message is the local timestamp of the TwinSAFE device. The age of the diagnostic message can be deduced by calculation with the current timestamp from the CoE object 0x10F8.	
	Bits 5 to 7	reserved	
	Bits 8 to 15	Number of parameters in this diagnostic message	

Dynamic parameters in the diagnostic messages

Type	Data type	Description
Flags parameter 1	UINT16	Describes the type of parameter 1
		Bits 12 to 15 = 0 Bits 0 to 11 = data type of parameter 1 0x0001 - BOOLEAN 0x0002 - INT8 0x0003 - INT16 0x0004 - INT32 0x0005 - UINT8

Type	Data type	Description
		0x0006 - UINT16 0x0007 - UINT32 0x0008 - REAL32 0x0011 - REAL64 0x0015 - INT64 0x001B - UINT64 Text parameters and formats are specified in ETG.2000.
Parameter 1	Data type in accordance with flags	Value of parameter 1
Flags parameter 2	UINT16	see Flags parameter 1
Parameter 2	Data type in accordance with flags	Value of parameter 2
...		

The diagnostic messages are saved in text form in the ESI/XML file belonging to the TwinSAFE device. On the basis of the Text ID contained in the diagnostic message, the corresponding plain text message can be found in the respective languages. The parameters can be inserted in the appropriate positions. In the following example, %x is used for a hexadecimal representation of the parameters.



Fig. 29: ESI/XML message text

Via the entry *New Messages Available* the user receives information that new messages are available. The messages can be read out via CompleteAccess (a CoE read command for the complete CoE object 0x10F3). The *New Messages Available* bit is reset after reading the messages.

The sending of emergency messages to the EtherCAT master is activated by adding the CoE object 0x10F3:05 to the startup list (Transition IP, value 0x0001). If new diagnostic messages arrive, they are entered in object 0x10F3 and additionally sent by emergency to the EtherCAT master.

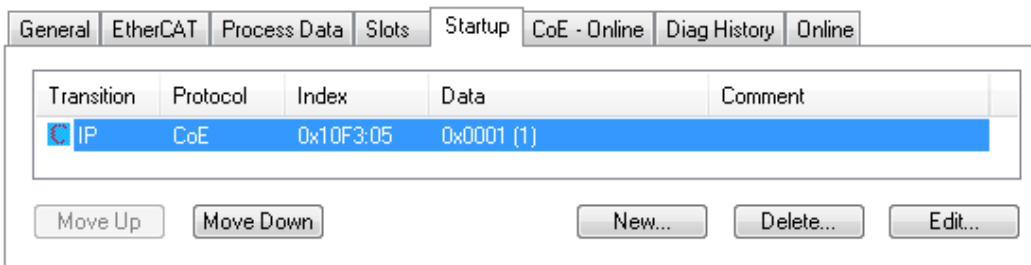

Fig. 30: Startup list

5.5.5 Diag History tab

All errors occurring within the TwinSAFE components are stored in their diag history. The diag history can be viewed by selecting the corresponding TwinSAFE component in the I/O tree structure and then selecting the *Diag History* tab. Use the *Update History* button to fetch the current data from the TwinSAFE component. Errors within the logic, the function blocks, the connections or the component itself are stored with a corresponding time stamp.

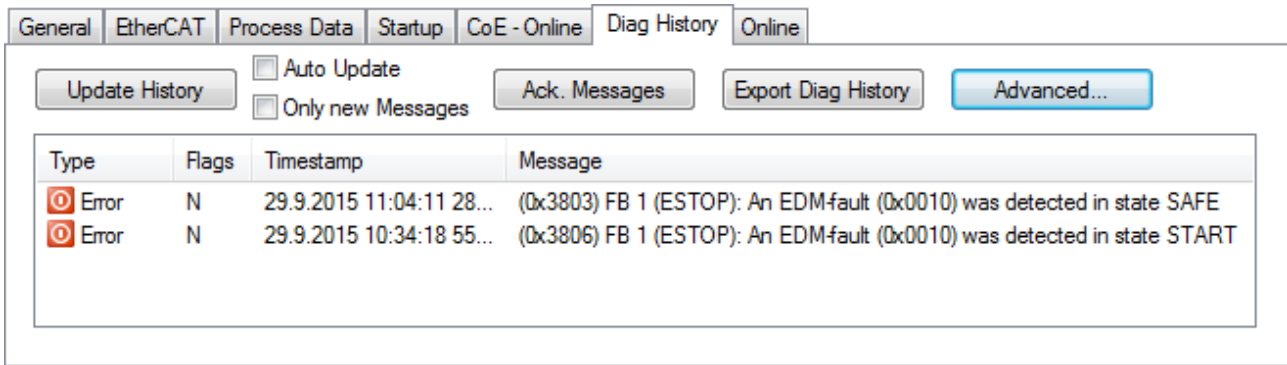

Fig. 31: Diag history

Use the *Advanced...* button to open the advanced settings. Here, the user can customize the behavior of the diag history.

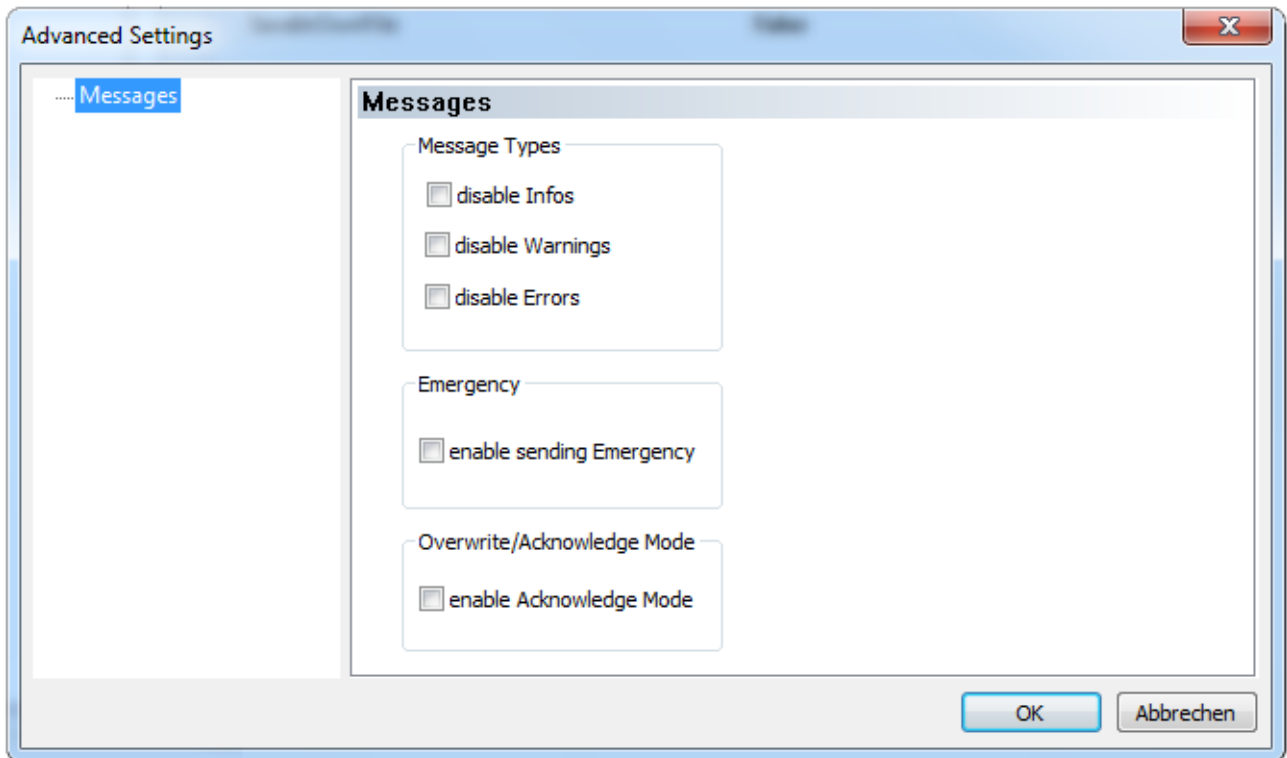

Fig. 32: Diag history – advanced settings

Advanced Settings

Setting	Description
Message Types	<ul style="list-style-type: none"> • disable Info Messages with the <i>Info</i> status are not saved in the diag history • disable Warnings Messages with the <i>Warning</i> status are not saved in the diag history • disable Errors Messages with the <i>Error</i> status are not saved in the diag history
Emergency	In addition to saving the message in the diag history, an emergency object is also sent and displayed in the TwinCAT logger window.
Overwrite / Acknowledge Mode	This setting is currently not supported.

5.6 Maintenance

Maintenance

The TwinSAFE components are maintenance-free!

Environmental conditions

⚠ WARNING

Observe the specified environmental conditions!

Please ensure that the TwinSAFE components are only stored and operated under the specified conditions (see technical data).

If the TwinSAFE component is operated outside the permitted temperature range it will switch to *Global Shutdown* state.

Cleaning

Protect the TwinSAFE component from unacceptable soiling during operation and storage!

If the TwinSAFE component was subjected to unacceptable soiling it may no longer be operated!

⚠ WARNING

Have soiled terminals checked!

Cleaning of the TwinSAFE component by the user is not permitted!
Please send soiled terminals to the manufacturer for inspection and cleaning!

6 Maintenance and cleaning

i Cleaning by the manufacturer only

Do not operate the TwinSAFE component if it is unacceptably dirty. Refer to the technical data for the protection class.

Send unacceptably dirty TwinSAFE component to the manufacturer for cleaning.

TwinSAFE components are basically maintenance-free.

6.1 Disassembly

Each TwinSAFE component is secured by a lock on the mounting rail.

To remove the TwinSAFE component, release the lock as follows:

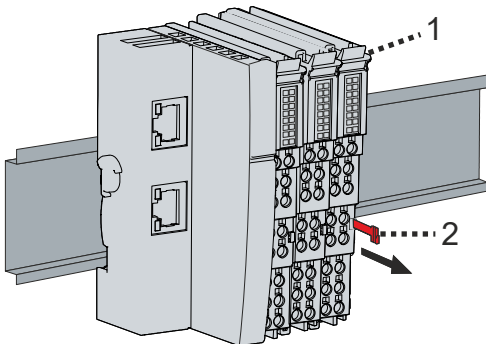

1. Pull the orange strap [2] approx. 1 cm out of the TwinSAFE component [1]

The mounting rail lock of the TwinSAFE component releases automatically.

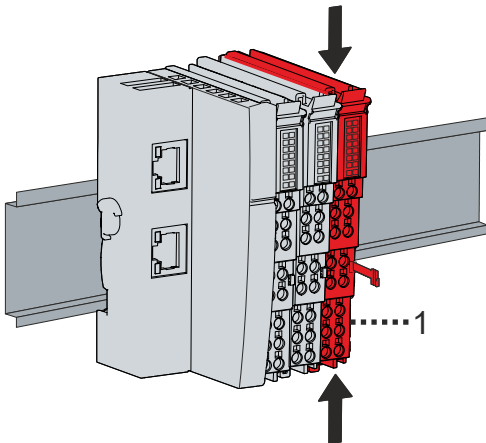

2. Use your thumb and index finger to grip the unlocked TwinSAFE component [1] simultaneously at the top and bottom of the housing surfaces

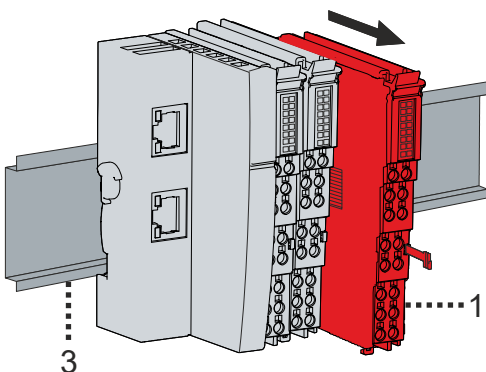

3. Pull the TwinSAFE component [1] out of the bus terminal block from the mounting rail [3] with little effort

7 Decommissioning

7.1 Disposal

NOTICE

Correct disposal

Observe the applicable national laws and guidelines for disposal.
Incorrect disposal may result in environmental damage.

Remove the TwinSAFE component for disposal.

Depending on your application and the products used, make sure that the respective components are disposed of properly:

Cast iron and metal

Hand over cast iron and metal parts to scrap metal recycling.

Cardboard, wood and polystyrene

Dispose of packaging materials made of cardboard, wood or Styrofoam in accordance with regulations.

Plastic and hard plastic

You can recycle parts made of plastic and hard plastic via the waste management center or reuse them in accordance with the component regulations and markings.

Oils and lubricants

Dispose of oils and lubricants in separate containers. Hand over containers to the waste oil collection point.

Batteries and accumulators

Batteries and accumulators may also be marked with the crossed-out wheeled garbage can symbol. You must separate these components from waste. You are legally obliged to return used batteries and accumulators within the EU. Outside the validity of the EU Directive 2006/66/EC, observe the respective regulations.

7.1.1 Returning to the vendor

In accordance with the WEEE-2012/19/EU directives, you can return used devices and accessories for professional disposal. The transport costs are borne by the sender.

Send the used devices with the note "For disposal" to:

Beckhoff Automation GmbH & Co. KG
Gebäude „Service“
Stahlstraße 31
D-33415 Verl

In addition, you have the option to contact a local certified specialist company for the disposal of used electrical and electronic appliances. Dispose of the old components in accordance with the regulations applicable in your country.

8 Appendix

8.1 Volatility

If there are requirements concerning the volatility of products in your application, for example of the U.S. Department of Defense or similar authorities or security organizations, the following process applies:

The product has both volatile and non-volatile components. Volatile components lose their data immediately after removing power. Non-volatile components keep the data even after loss of power.

If there is customer specific data saved on the product, it cannot be ensured that this data might not be restored through for example forensic measures, even after the data is deleted through the provided tool chain. If this data is confidential, the scrapping of the product after usage is recommended to protect this data.

8.2 Focus of certificates

The most decisive document for certified components of the TwinSAFE department is the EC type examination certificate. The document contains both the test coverage and the regarded component and component family.

The current certificates of all TwinSAFE components with the underlying standards and directives can be found at <https://www.beckhoff.com/en-en/support/download-finder/certificates-approvals/>.

If the document refers only to the first four figures of a product (ELxxxx), the certificate is valid for all available variants of the component (ELxxxx-abcd). This is applicable for all components like EtherCAT Terminals, EtherCAT Boxes, EtherCAT plug-in modules and Bus Terminals.

CERTIFICADO ◆ CERTIFICADO ◆ CERTIFICADO ◆ CERTIFICADO ◆



EC-Type Examination Certificate

No. M6A 062386 0055 Rev. 01

Holder of Certificate:	Beckhoff Automation GmbH & Co. KG Hülshorstweg 20 33415 Verl GERMANY
Product:	Safety components
Model(s):	EL1918
Parameters:	Supply voltage: 24VDC (-15%/+20%) Ambient temperature: -25°C...+55°C Protection class: IP20

This EC Type Examination Certificate is issued according to Article 12(3) b or 12(4) a of Council Directive 2006/42/EC relating to machinery. It confirms that the listed Annex-IV equipment complies with the principal protection requirements of the directive. It refers only to the sample submitted to TÜV SÜD Product Service GmbH for testing and certification. For details see: www.tuvsud.com/ps-cert

Test report no.:	BV99670C
-------------------------	-----------------

◆ CERTИФИКАТ ◆ CERTИФИКАТ ◆ CERTИФИКАТ ◆ CERTИФИКАТ ◆



If you regard the example EL1918 in the picture, the certificate is valid for both the EL1918 and the available variant EL1918-2200.

List of figures

Fig. 1	Slot and key system and screwless (spring-loaded) connection system	17
Fig. 2	Bus Coupler (EtherCAT)	18
Fig. 3	Overview of EtherCAT Terminals.....	19
Fig. 4	EL1918 – TwinSAFE Terminal with 8 fail-safe inputs	22
Fig. 5	Characteristic curve of the inputs.....	27
Fig. 6	EL1918 dimensions.....	28
Fig. 7	Spring contacts of Beckhoff I/O components.....	31
Fig. 8	Installation position and minimum distances.....	32
Fig. 9	Thermally unfavorable arrangement of the TwinSAFE terminals.....	34
Fig. 10	Thermally favorable arrangement of the TwinSAFE terminals.....	34
Fig. 11	Installation on the mounting rail	35
Fig. 12	Removal from mounting rail	36
Fig. 13	PE power contact.....	37
Fig. 14	Connection of a cable to a terminal point.....	38
Fig. 15	EL1918 connection	39
Fig. 16	Cable routing.....	40
Fig. 17	Adding an EL1918.....	41
Fig. 18	Address settings on TwinSAFE terminals with 1023 possible addresses.....	42
Fig. 19	Selection from the I/O tree	43
Fig. 20	Creating alias devices by the user	44
Fig. 21	Linking tab of the alias device	44
Fig. 22	Connection tab of the alias device	45
Fig. 23	EL1918 parameters.....	45
Fig. 24	Process image of the EL1918	46
Fig. 25	Deleting the project data	47
Fig. 26	Typical response time	48
Fig. 27	Worst case response time.....	50
Fig. 28	Status LEDs	51
Fig. 29	ESI/XML message text.....	54
Fig. 30	Startup list	54
Fig. 31	Diag history	55
Fig. 32	Diag history – advanced settings	55

More Information:
www.beckhoff.com/EL1918

Beckhoff Automation GmbH & Co. KG
Hülshorstweg 20
33415 Verl
Germany
Phone: +49 5246 9630
info@beckhoff.com
www.beckhoff.com

