







GFX

HEPCO GUIDANCE SYSTEM FOR BECKHOFF XTS

GFX – HEPSCO GUIDANCE SYSTEM FOR BECKHOFF XTS

-  Speeds: up to 4m/s
-  Low maintenance
-  Unlimited lengths
-  Long system life
-  Works in dirty environments
-  Quiet and smooth running

Hepco's GFX Guidance System for Beckhoff XTS meets the needs of higher duty cycle XTS applications, providing a precise, robust and durable guidance solution.

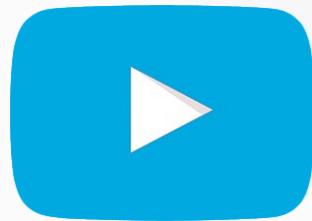
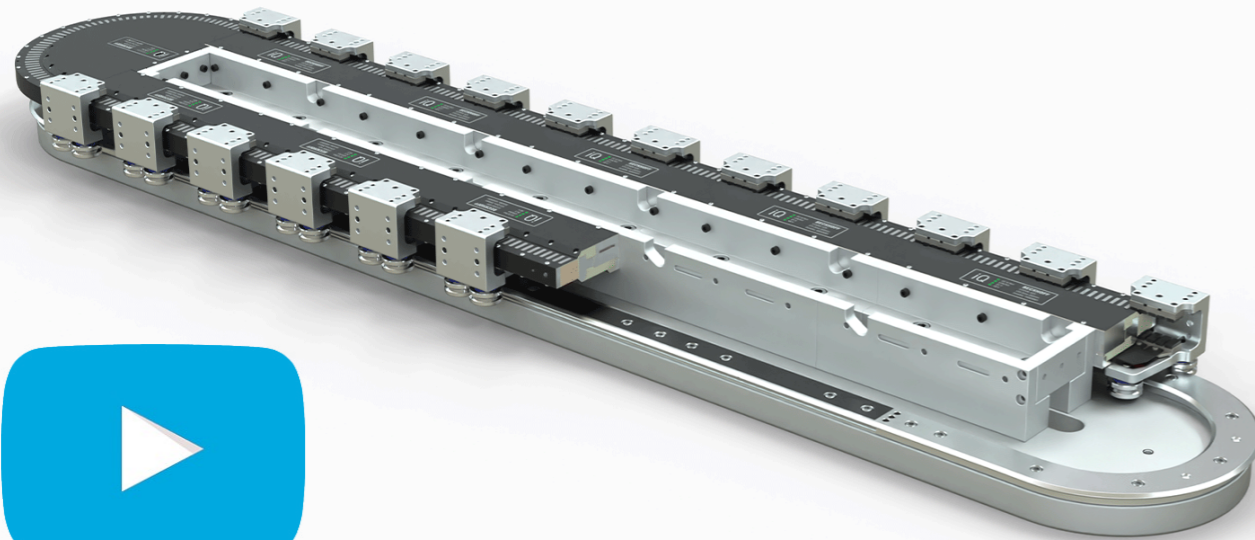

Contents

Introduction	1
GFX 1TL System Composition	3
GFX PRT2 System Composition	4
Application Examples	5-6
GFX Product Family	7-10
Technical Data	11-12
System and Component Specification	13-16

HepcoMotion and Beckhoff – HepcoMotion works in partnership with Beckhoff to create the GFX system, a high-end track system that provides the support and rigidity required for precise XTS applications.

Flexible – The Beckhoff XTS Transport System uses linear motor technology to independently drive movers around a track. This allows work processes of different duration to be combined, on the fly product changes, and the addition or removal of work stations as needed.

Precise and reliable – GFX provides the transport path and mechanically guides the movers along the motor modules at the defined speed, with great precision, ensuring accurate alignment and resistance to deflection.

Long system life – GFX is designed to accommodate complex, high-speed motion profiles requiring extended duty cycles.

Increased Load Capacity – GFX Strong Mover designed to accommodate press load applications.



GFX 1TL System Composition

GFX 1TL Systems

GFX 1-Trak Lite is a spacer slide version of Hepco's 1-Trak guidance system, including a patented curved track form, providing the minimum acceleration path around a tight curve of the 180° motor modules. The track system is mounted on an aluminium baseplate along with a set of motor support brackets, or can be supplied as a track system only for custom installation. Its length is only limited by the number of motors and movers supported by a Beckhoff control system. Please see page 11 or contact Beckhoff for information on these limitations.

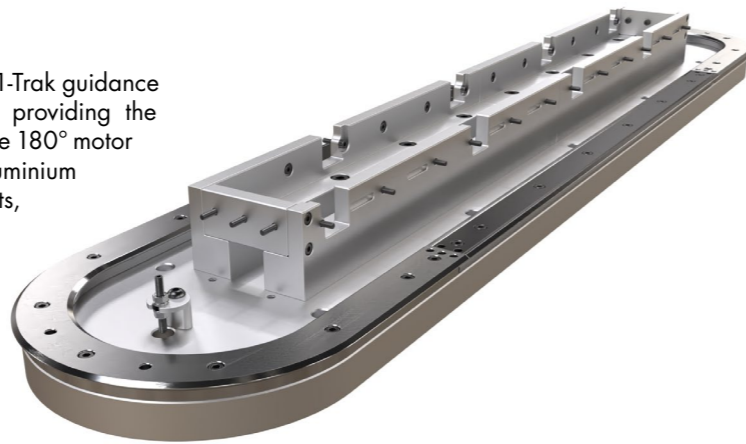

1-Trak Lite systems use three-bearing mover designs.

- 25mm outer bearings
- Most compact mover
- Lowest mover mass
- Suitable for light moment loads
- Available in standard lengths: 54mm and 74mm



- 34mm outer bearings
- Compact mover
- Low mover mass
- Suitable for medium moment loads
- Available in standard lengths: 72mm and 82mm

On request Hepco guidance systems can be supplied fully assembled with Beckhoff motor modules, mover magnets and mover encoder flags. Please speak to Hepco's technical department to discuss your requirement.

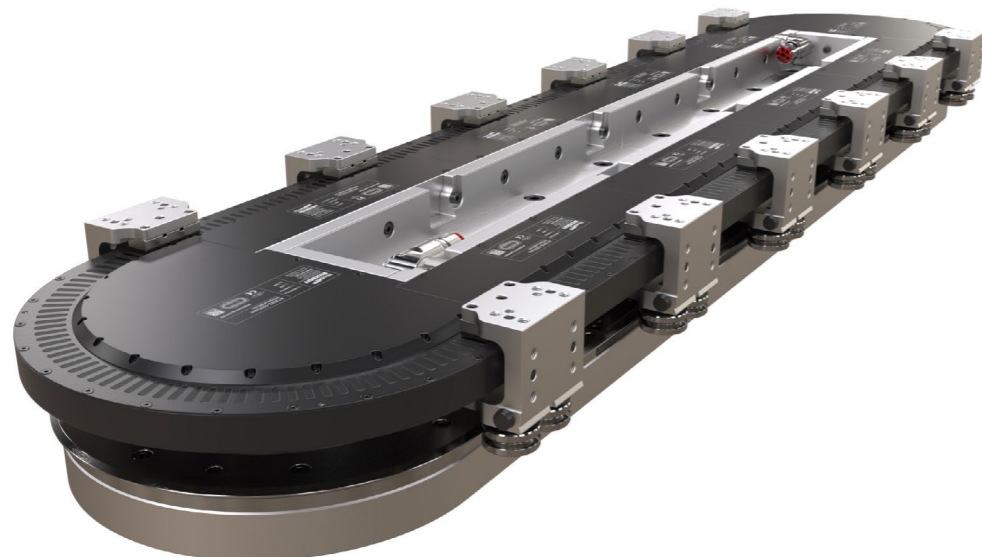
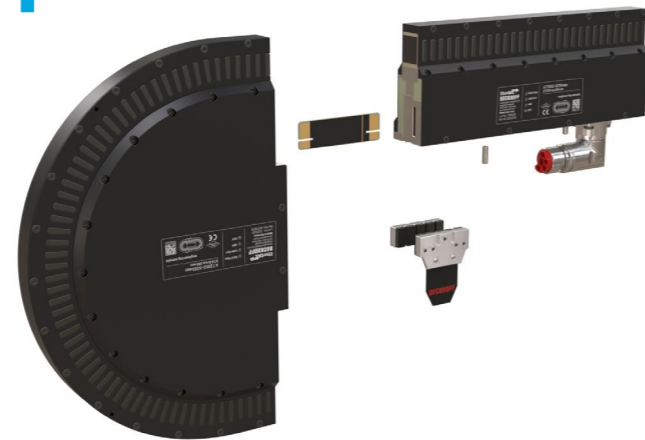

GFX PRT2 System Composition

PRT2 Ring and Track Systems

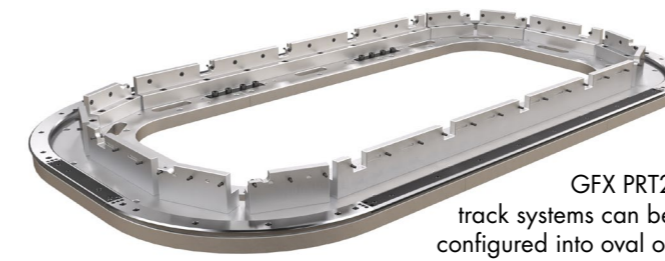

GFX PRT2 track systems can be configured into oval or rectangular systems.

PRT2 Ring Systems



GFX PRT2 ring and track systems use four-bearing fixed centre movers.



- All 25mm bearings
- Compact high moment mover
- Low mover mass
- Suitable for medium loads
- 52mm long as standard

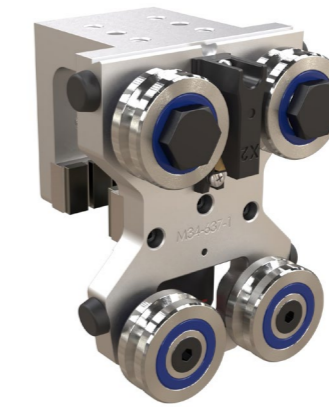

- All 34mm bearings
- Longer bearing life
- Lubricator option
- Suitable for heavier loads
- 80mm long as standard



- **NEW** Strong Mover
- 34mm or 40mm bearings
- Longer bearing life
- Suitable for very heavy loads
- 100mm long as standard



On request Hepco guidance systems can be supplied fully assembled with Beckhoff motor modules, mover magnets and mover encoder flags. Please speak to Hepco's technical department to discuss your requirement.

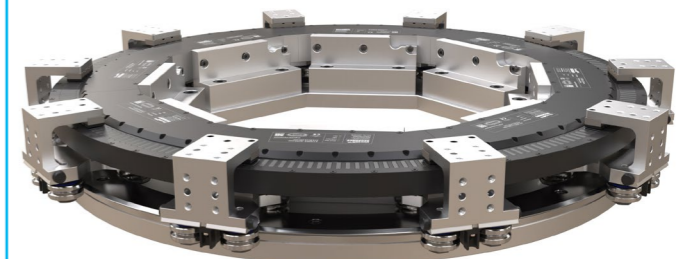
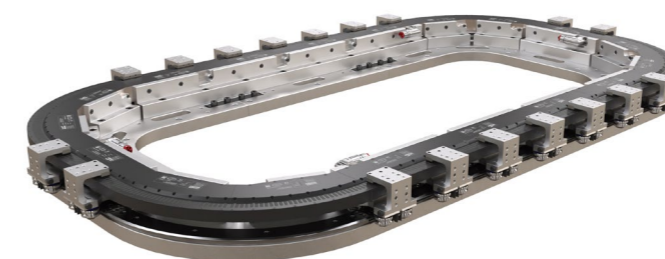

Application Examples - Features and Benefits

High Speed Lane Divider

This example shows a vertically mounted, lightly loaded, high speed and high duty GFX 1-Trak system being used to sort randomly positioned items into two separate lanes.

- High rigidity
- Positional repeatability
- Durable - hardened guidance system
- Low maintenance - integrated bleed lubrication
- Standard configuration

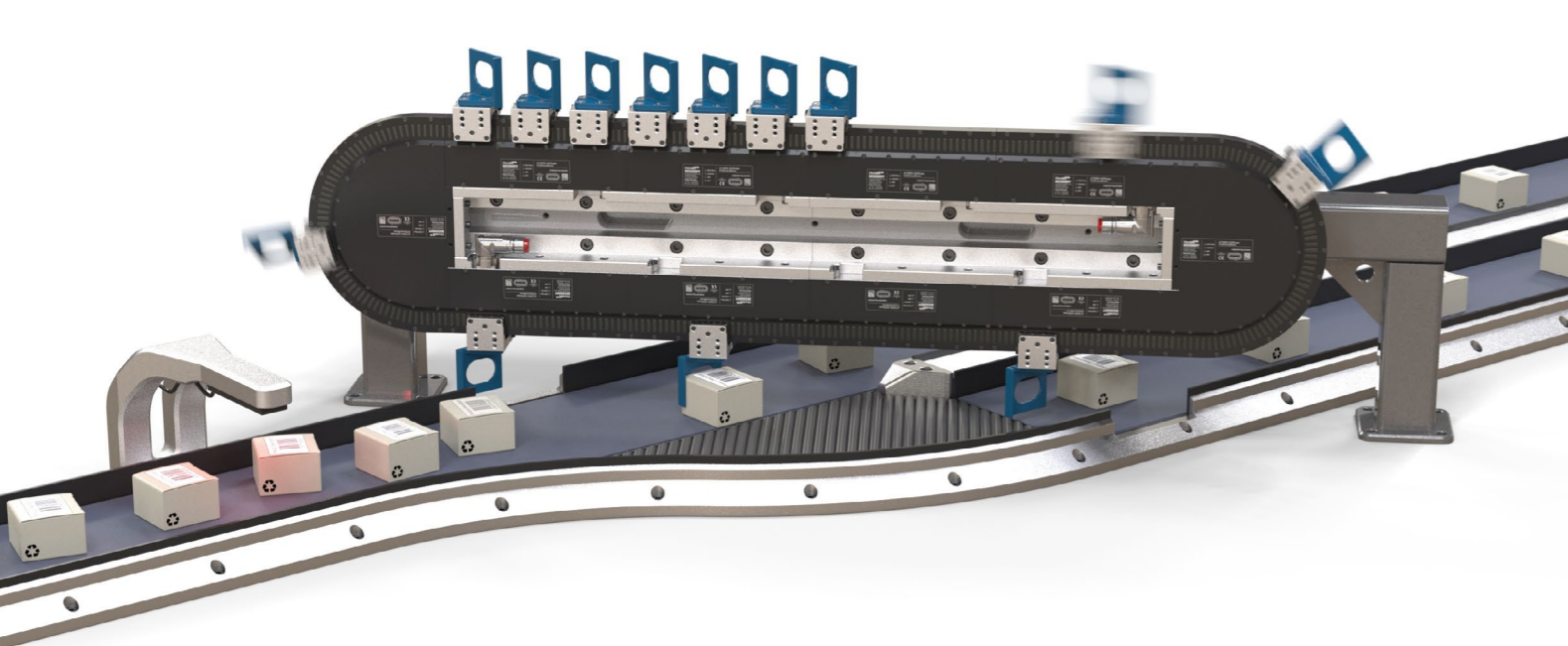

Double Sided System

Two GFX 1-Trak systems manufactured with a single 'back to back' base provides a precision assembly and accurate parallelism for applications where the relevant positions on track systems must be closely controlled.

- High rigidity
- Excellent parallelism
- Positional accuracy
- Compact
- Customisable - designed to suit a specific application

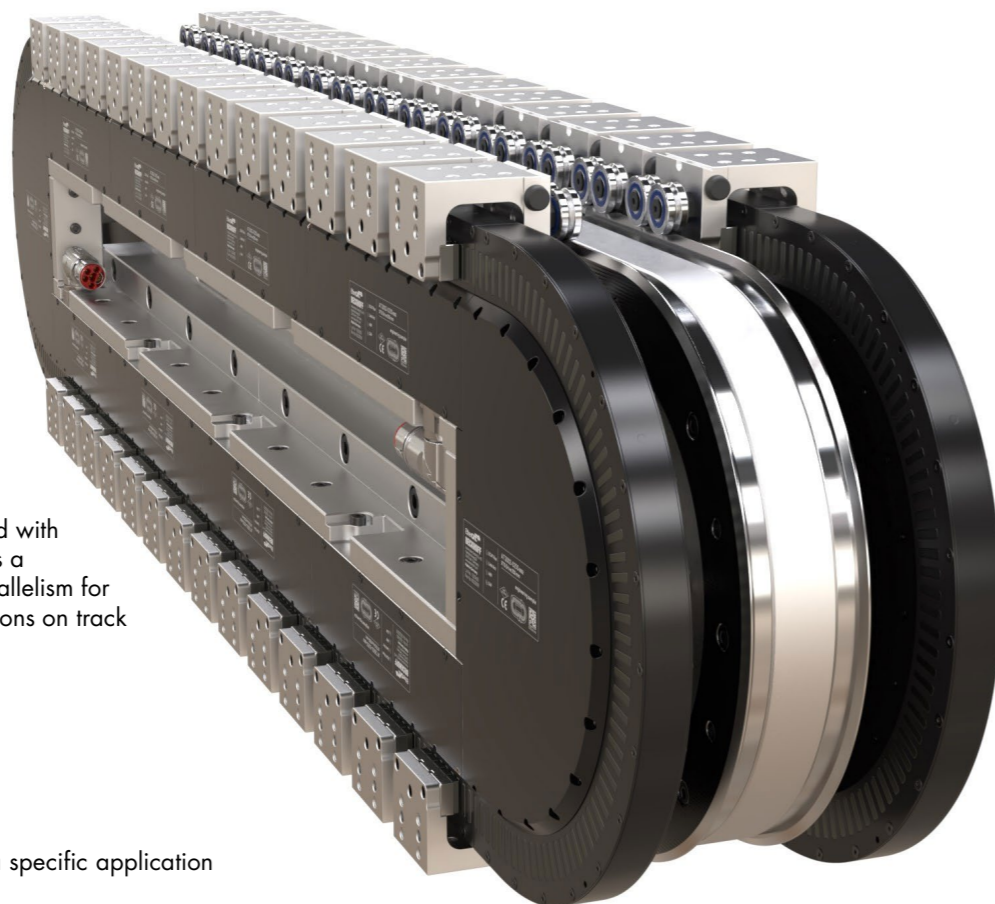

Application Examples - Features and Benefits

Multi-Operation and Variable Speed Application

The horizontally mounted system shown below comprises of a GFX PRT2 track system used in a multi operation application.

- Durability - hardened guidance system
- High moment capacity - for higher process forces
- Low maintenance - integrated bleed lubrication
- Machine integration - Hepco MCS support structure
- Precision ring and track technology (PRT2)
- Standard configuration

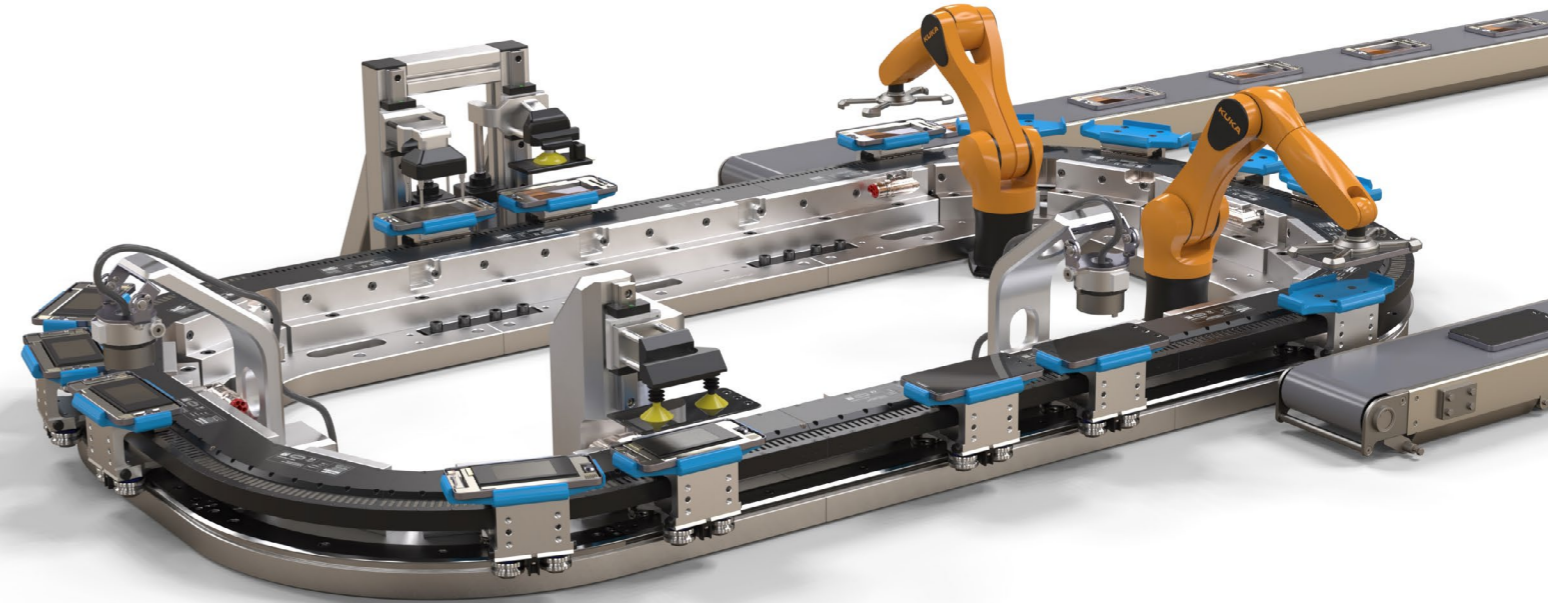

Multidirectional Bend

This application utilises 180° end modules, plus internal and external 22.5° curved Beckhoff modules, creating an 'S' bend system layout, with a GFX 1-Trak Lite track system.

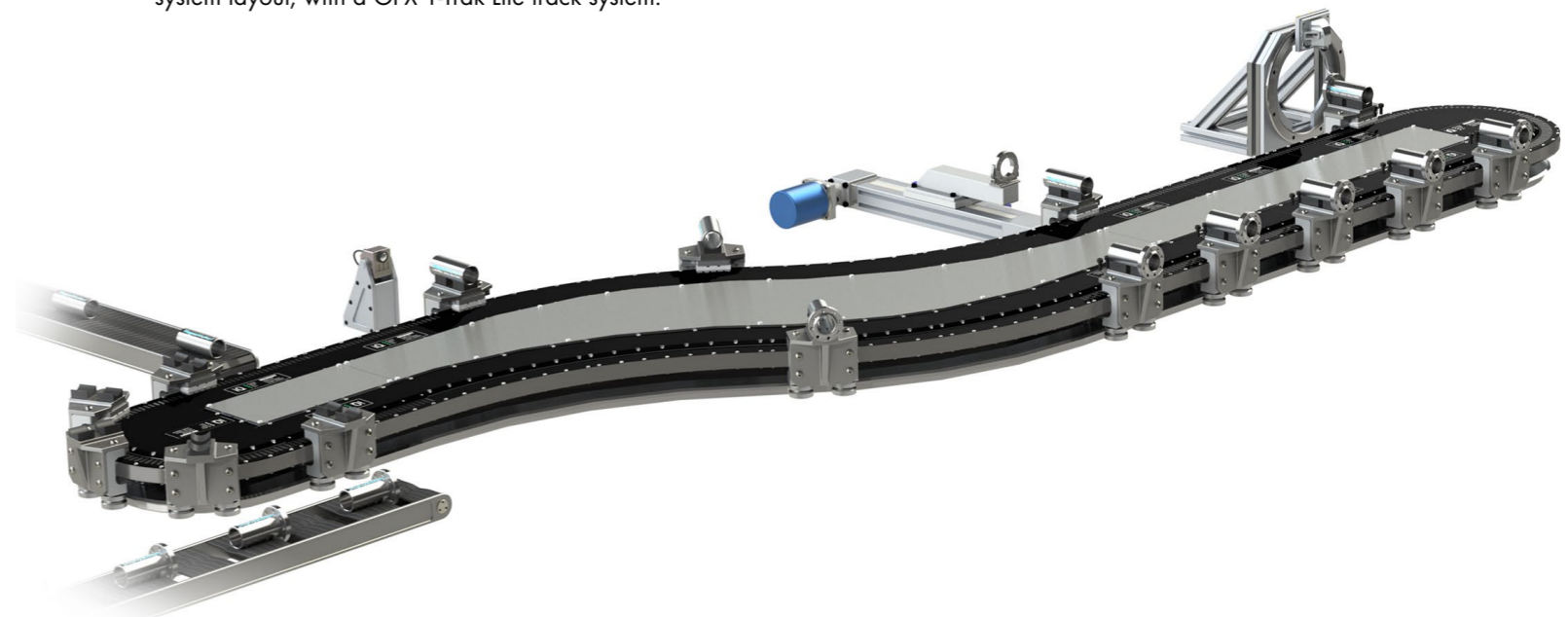

- Long and more complex systems available
- High load capacity
- Positional repeatability
- Flexible layout - patented track geometry
- Customisable - designed to suit a specific application

GFX-a ↓

GFX Agile is a low mass variant of the standard GFX track system for Beckhoff XTS products. It is specified for overall payloads (product and tooling combined) of less than 250g, with little or no process loading. It is capable of a maximum velocity of 4m/s and acceleration in excess of 100m/s². It offers very high throughput rates in excess of 700ppm.

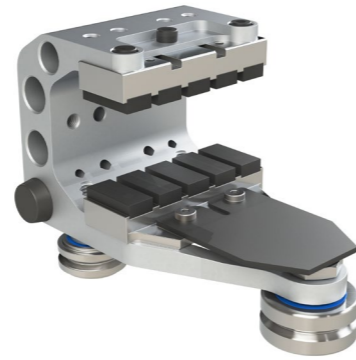

GFX Strong Mover ↓

GFX Strong Movers are exclusively designed for the GFX-PRT2 ring and track systems for use with 45° and 22.5° XTS motors. They accept press loads and robotic assembly forces up to 2500N. This is 10 times higher than the standard mover.

This increase in press load capacity is at minimal cost to the dynamic capability of the XTS drive system. Dynamic payload capacity (tooling and payload) is around twice that of the standard mover.



GFX TMS - Track Management System ↓

GFX Track Management (TMS) facilitates the transition of movers between GFX systems whether they are open or complete circuits. Track Management can be utilised in many ways to increase system functionality, including the removal of movers for maintenance, system re-configuration or for the transfer of movers between systems to accommodate extra processes.

The precision ballscrew driven transfer slide section can achieve cycle times as quick as 0.4 seconds to micron precision. The TMS assembly is designed to be integrated into standard 1-Trak and PRT2 assemblies. TMS Systems require rigid support structures which will be tailored to suit specific customer applications.

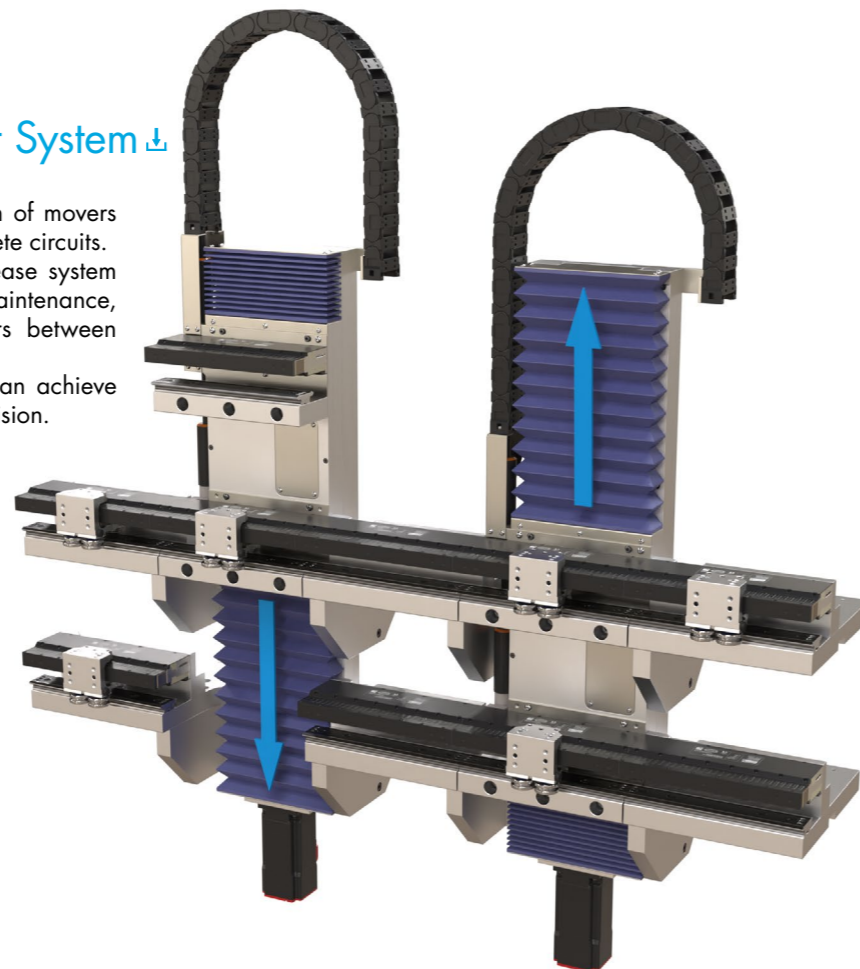

GFX-h ↓

GFX Hygienic Design comprises track system variations that are suitable for use with the Beckhoff "HD" hygienic design XTS motors and magnets. There are three systems which are applicable to differing customer needs:

GFX-hw Washdown

Designed for cleaning in place (CIP) operations that include foaming agents, hot washing and pressure washing. The construction allows complete access to all surfaces, pooling traps are removed, joints between all components are sealed and the bearings are protected against lubricant egress and "flushing" with a solid cover and labyrinth seals. All fasteners are sealed and designed to ease cleaning processes.

GFX-hc Cleandown

Suitable for "wet" cleaning and uses a structure that is very similar to a standard GFX, but modified to fit the HD (Hygienic Design) motors. Ideally suited for applications in pharmaceutical, food and other processes that require wet cleaning with benign liquids or wet wipes to remove surface contamination. Fasteners are grade A2 stainless steel.

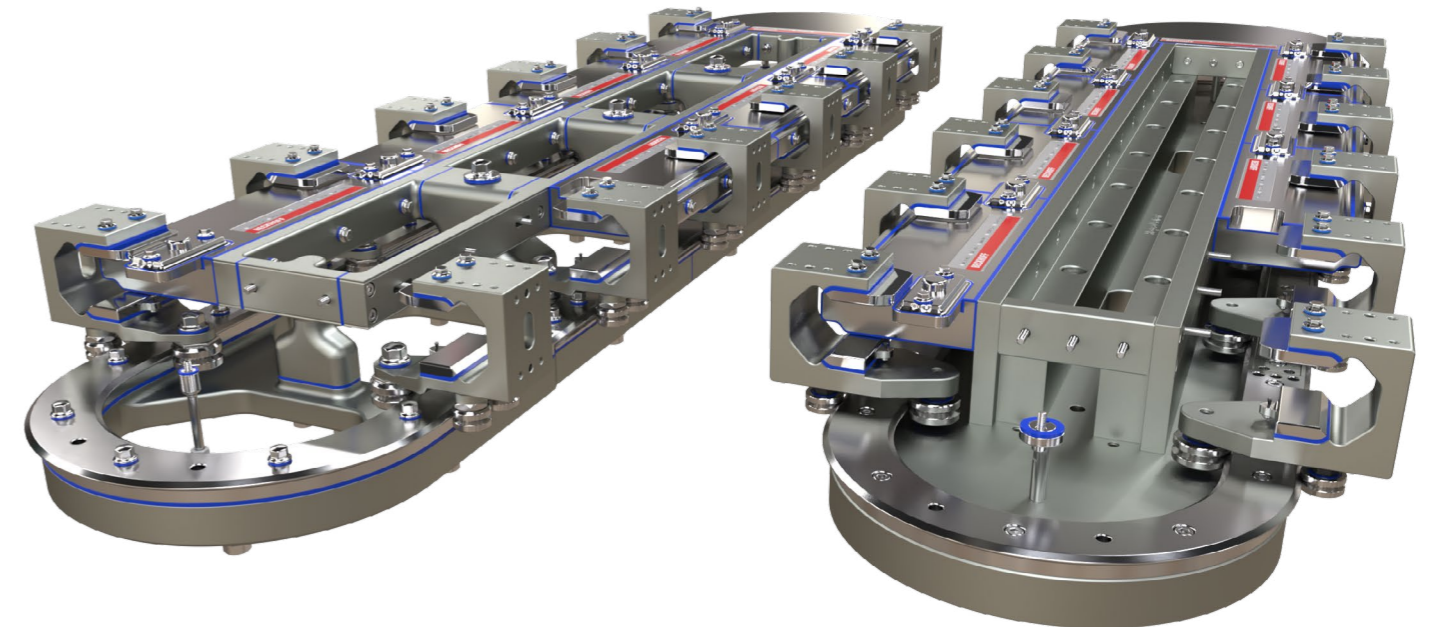

GFX-ha Aseptic

Fully stainless steel construction, has applications in pharmaceutical and other processes where aggressive cleaning chemicals are used.

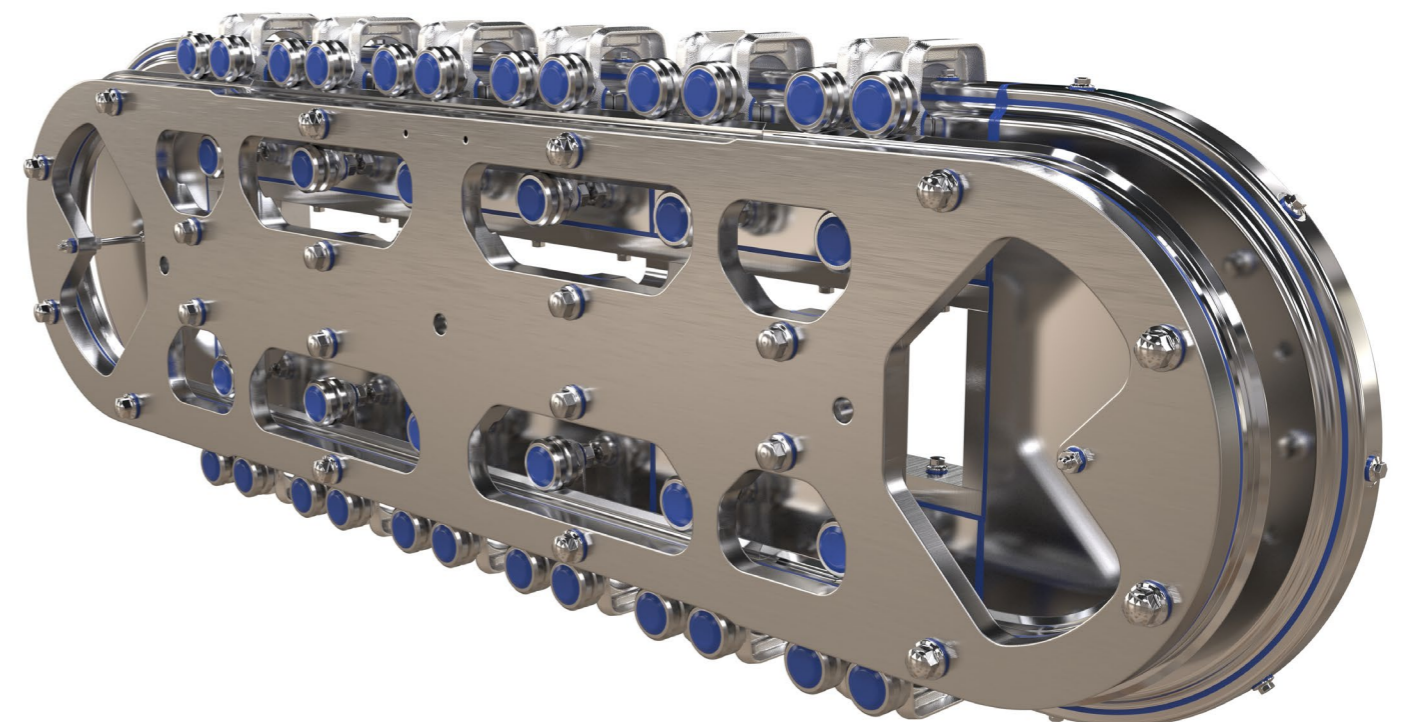

GFX-r ↓

GFX-r provides the hardware for machine movements in rectangular paths. The absence of curved motor sections allows movers to be much stronger, more powerful and with a larger mounting platform, while maintaining accuracy, durability and agility. Mover speeds of 4m/s, payloads up to 100kg and press loads up to 7200N are possible. Movers with longer magnet arrays can also reduce heating losses by up to 60%.

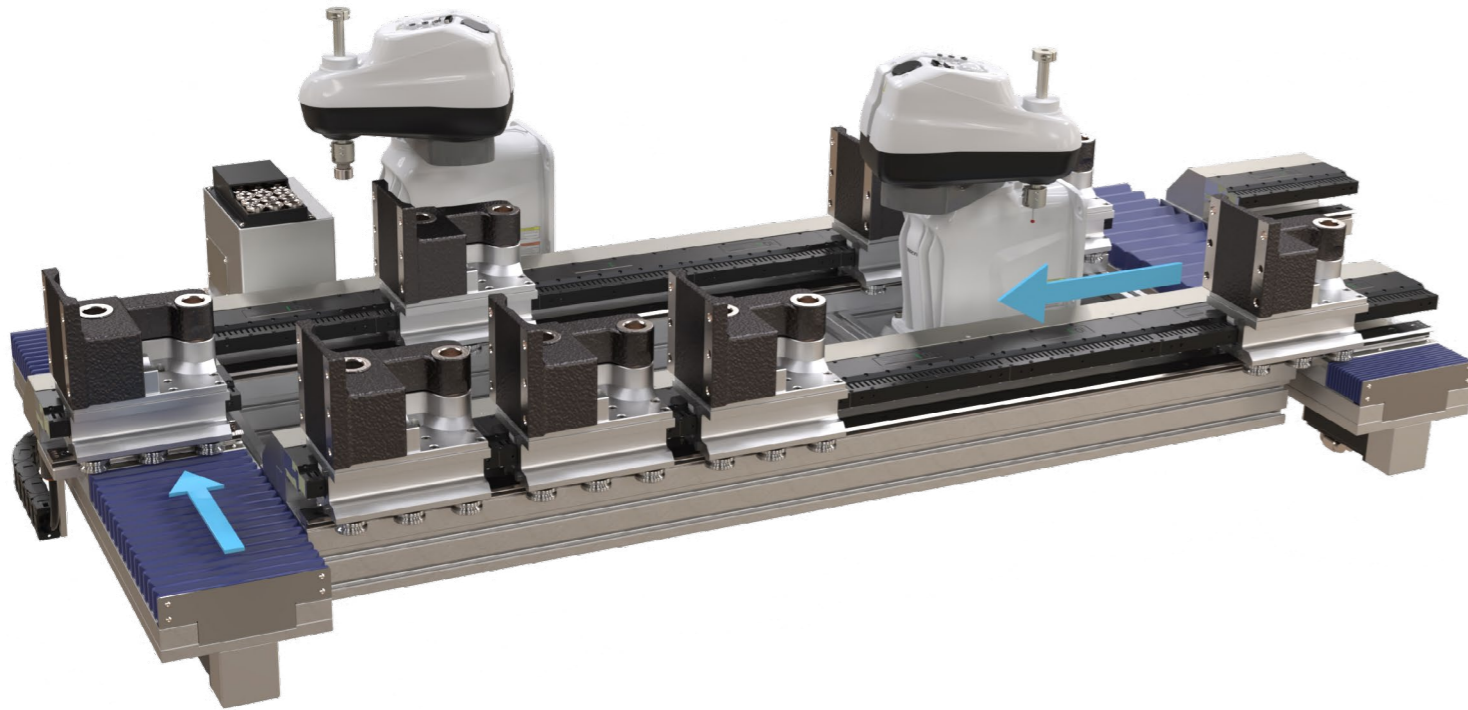

GFX-r systems will often be used in machine cells incorporating robots, power tools and sensors for automated assembly and inspection systems. The illustration below shows an example application to give an idea of what can be achieved

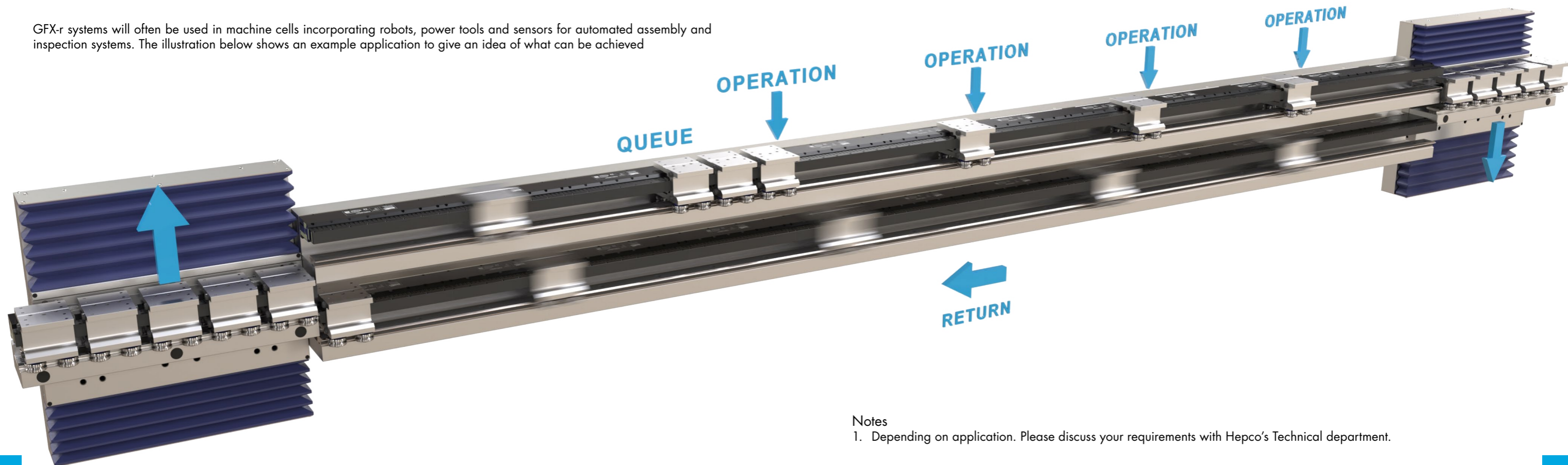

GFX-r is available with a range of mover sizes. These are tailored to a specific range of payloads from 10kg up to 100kg*1. 4 or 6 bearing movers available for increased strength and stability.

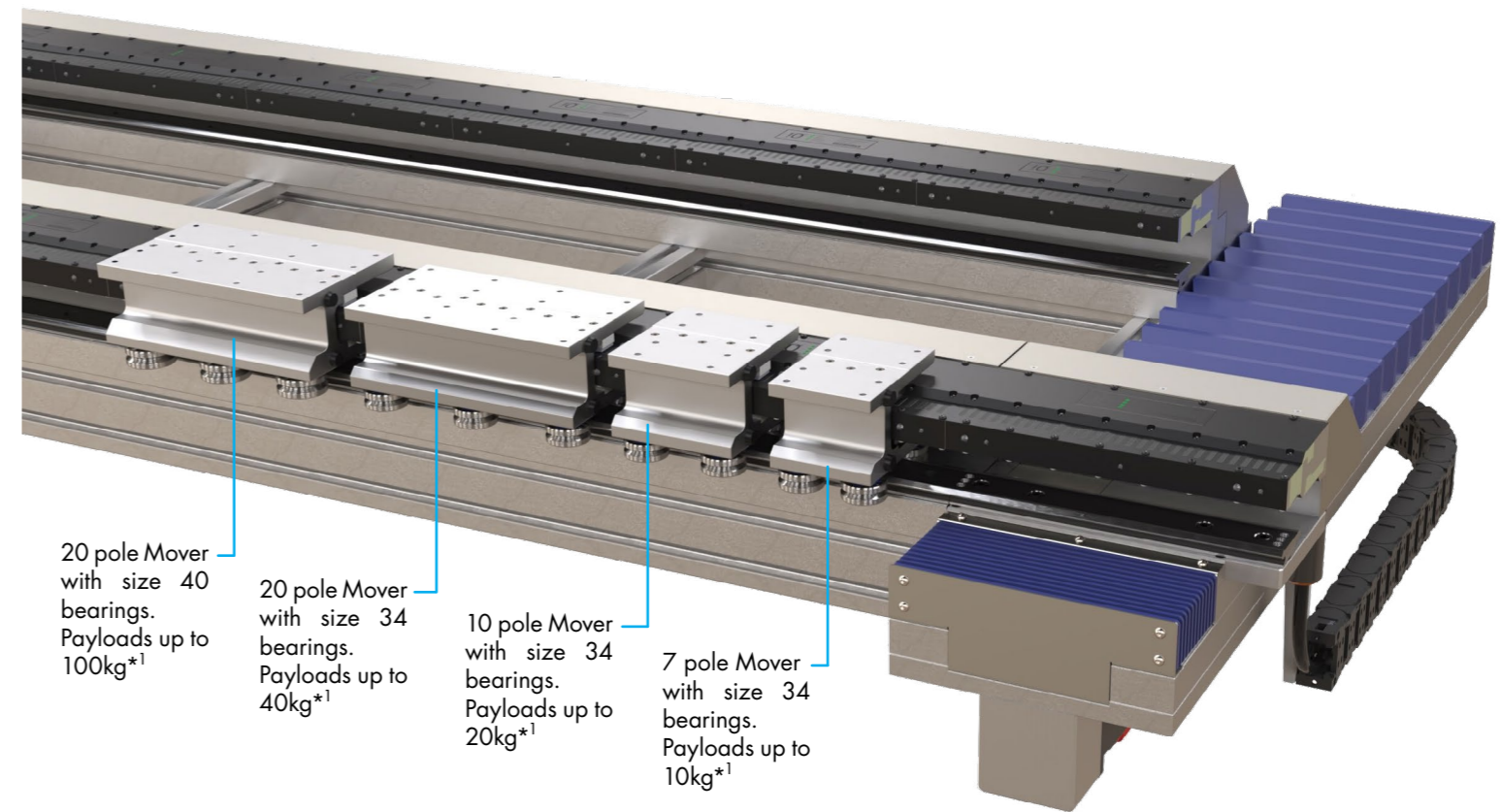

20 pole Mover with size 40 bearings. Payloads up to 100kg*1

20 pole Mover with size 34 bearings. Payloads up to 40kg*1

10 pole Mover with size 34 bearings. Payloads up to 20kg*1

7 pole Mover with size 34 bearings. Payloads up to 10kg*1

Notes

1. Depending on application. Please discuss your requirements with Hepco's Technical department.

System and Component Specification - GFX 1-Trak Systems

GFX 1-Trak Systems

Corrosion resistant systems use all stainless steel track components.

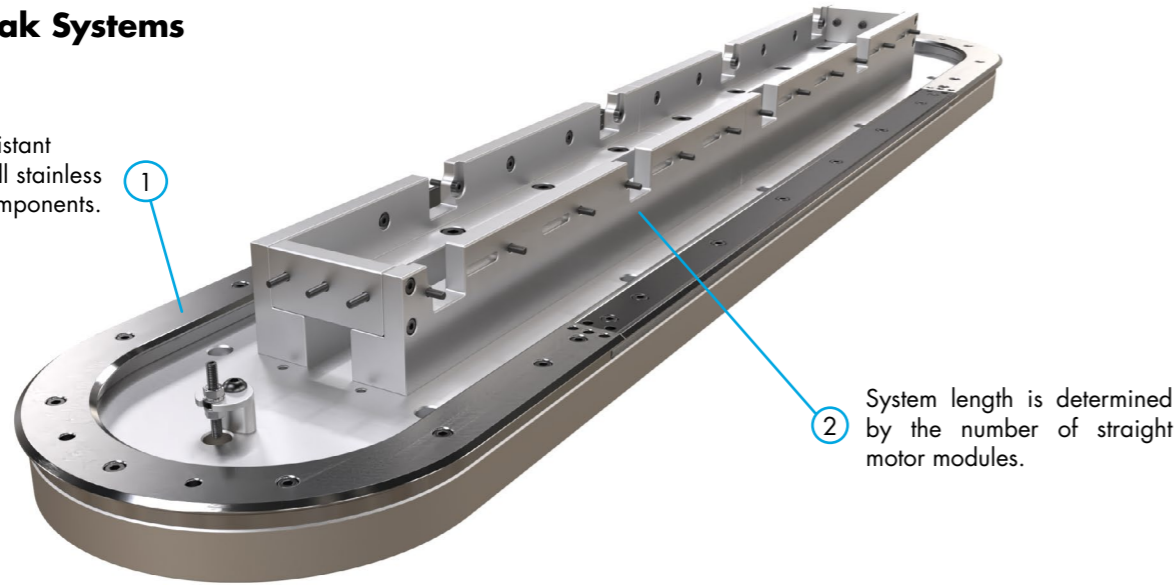

2 System length is determined by the number of straight motor modules.

Product GFX
Corrosion Resistant Option (1)
System Type ITL - 1-Trak Lite (See page 3)
System Length (2)
Product Code: GFX - (CR) - ITL - 4M - B

Movers

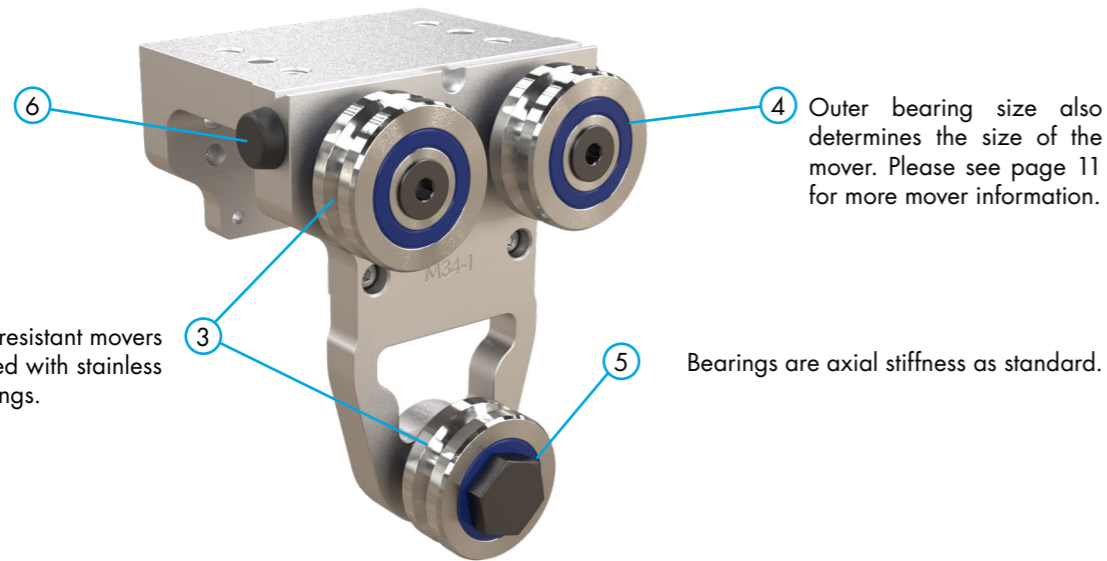

4 Outer bearing size also determines the size of the mover. Please see page 11 for more mover information.

5 Bearings are axial stiffness as standard.

Corrosion resistant movers are supplied with stainless steel bearings.

Product GFX
Corrosion Resistant Option^{*3} (3)
Mover Type ITC - 1-Trak Mover
Mover Size (4)
No Cable Technology^{*3,5} NCT - Holes to fit No Cable Technology
Collision Mitigation^{*3} CM - Buffers Fitted
Bearing Type AS - Axial Stiffness
Magnet Pole Size 7P - M34 only
Product Code: 10 x GFX2 - (CR) - ITC - M34 - 7P - AS - (CM) - (NCT)

System and Component Specification - GFX PRT2 Systems

GFX PRT2 Track Systems

Corrosion resistant systems use all stainless steel track components.

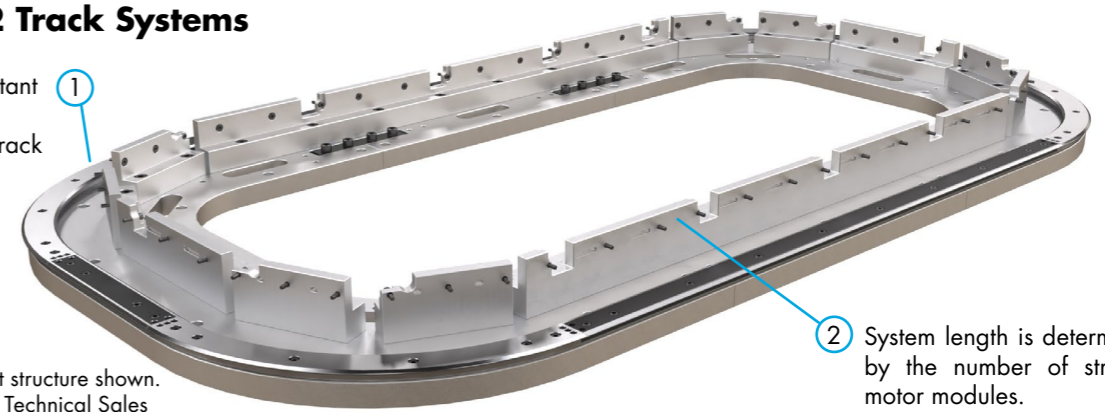

2 System length is determined by the number of straight motor modules.

Optional support structure shown. Contact Hepco's Technical Sales Department for more information.

Product GFX
Corrosion Resistant Option (1) (Leave blank if not required)
System Size (See page 12)
Segment Diameter
Product Code: GFX - (CR) - 637 - OVAL-4M - B

Movers

Corrosion resistant movers are supplied with stainless steel bearings.

Bearings are axial stiffness as standard.

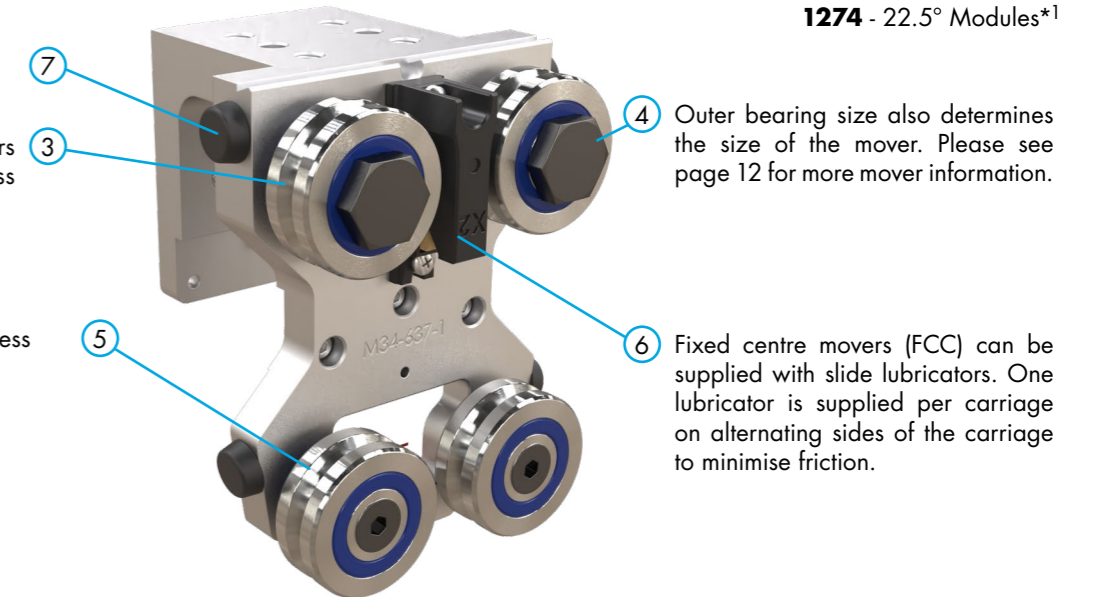

4 Outer bearing size also determines the size of the mover. Please see page 12 for more mover information.

6 Fixed centre movers (FCC) can be supplied with slide lubricators. One lubricator is supplied per carriage on alternating sides of the carriage to minimise friction.

Product GFX
Corrosion Resistant Option^{*3} (3)
Mover Type FCC - Fixed centre (PRT2)
Segment Diameter
Mover Size (4)
No Cable Technology^{*3,5} NCT - Holes to fit No Cable Technology
Collision Mitigation^{*3} CM - Buffers Fitted
Additional Options^{*3} LB - Slide lubricators
Bearing Type AS - Axial Stiffness
Magnet Pole Size
Product Code: 20 x GFX2 - (CR) - FCC - 637 - M34 - 7P - AS - (LB) - (CM) - (NCT)

Notes

- 360° GFX ring systems using 22.5° motor modules and 1274mm diameter rings require 16 motor modules.
- All movers are supplied fully assembled and adjusted to a system, unless requested otherwise.
- Leave blank if not required.
- Corrosion resistant version not available on M40 bearing option.
- Please see page 15 for more details on NCT.

NCT - No Cable Technology

NCT enables contactless, continuous power and data transmissions to the GFX mover (with NCT fitted). This allows functions to take place directly on the mover, for example scanning bar codes, measurements of weights, stacking options as shown below. Please discuss with Beckhoff XTS-Support@beckhoff.com before ordering to check it is compatible with your application.

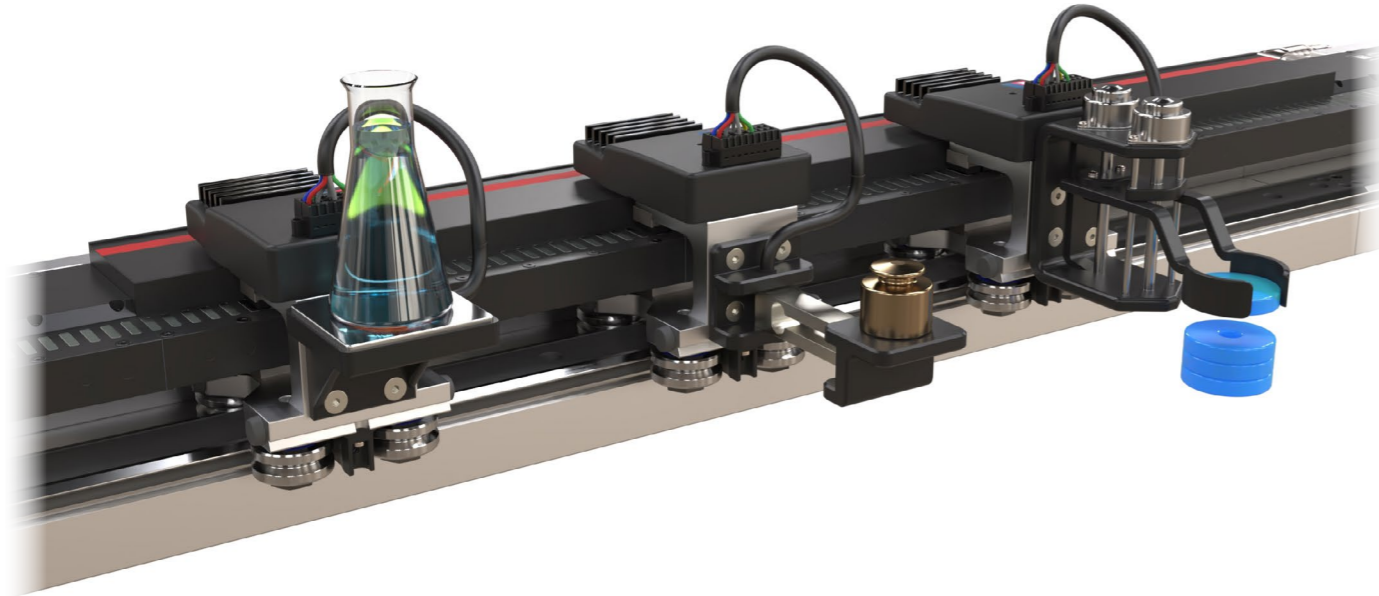

Bleed Lubrication

Sufficient lubrication is essential for all Hepco guidance systems for Beckhoff XTS. All systems incorporate a bleed lubrication facility, which channels lubricant directly to the V faces of the slide.

Lubricant is then distributed around the system by the movers. This process can be aided with lubricators mounted on movers (PRT2 systems only).

It is highly recommended that lubrication ports are situated approximately every 3 metres of track. For more information on lubrication requirements, flow rates and food grade lubricants, please see the [GFX Lubrication datasheet](#).

For more information please contact Hepco's technical department.

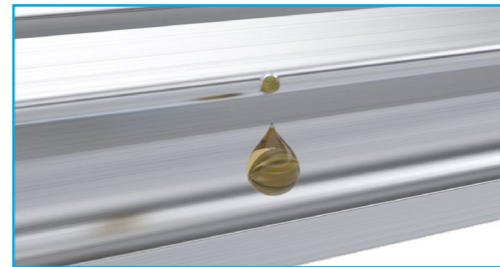

System Loading

Fundamental GFX mover geometry determines the life of the system. The loads applied both directly (L1 & L2), size and position of the payload combined with the acceleration (M, Ms & Mv) allow for an accurate and reliable life calculation to be obtained.

Please contact Hepco's technical department for more detailed information on system loading to suit a specific application.

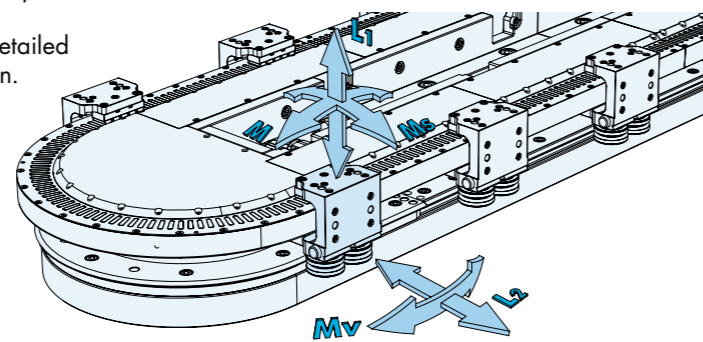

Further Information

Please visit hepcotion.com to access more information on the GFX product range or alternatively contact Hepco's technical department who will be happy to discuss your requirement.



Ring Slides & Segments

Material and finish: **Standard version:** High carbon steel, hardened on V faces. Ground on all main surfaces to N5 finish.
Stainless steel version: Special martensitic stainless steel generally conforming to 420 series, hardened on V faces. Ground on all main surfaces to N5 finish.

Track System Slides

Material and finish: **Standard version:** High carbon-chromium steel, hardened on V faces. Ground on all main surfaces to N5 finish, other faces chemically blacked.
Stainless steel version: Special martensitic stainless steel generally conforming to 420 series, hardened on V faces. Ground on all main surfaces to N5 finish.

Bearings

Bearing rings, balls, rollers: **Standard version:** Bearing steel AISI 52100 hardened and tempered.
Stainless steel version: AISI 440C stainless bearing steel, hardened and tempered.
Seals: **Standard version:** Nitrile rubber.
Hygienic hW &hA: FKM (Flouroelastomer)
Cages: Plastic.
Studs: **Standard version:** High tensile steel with chemical black finish.
Stainless steel version: AISI 303 series stainless steel.

Movers & Support Structures

Material: High strength aluminium alloy
Finish: Clear anodised

Lubricators

Material: Impact resistant plastic with felt wiper.

Frictional Resistance for 'V' Slide Systems

Coefficient of friction (without Lubricators) = 0.02
Lubricators add friction as follows:
One Lubricator per Carriage, SSLB34 = 1.5N.

External Lubrication

Lubricators should be oiled using 68 cSt viscosity or similar oil. Food compatible lubricants can also be used.

CATALOGUE No. GFX Hepco Guidance System for Beckhoff XTS 06.4 UK © 2024 Hepco Slide Systems Ltd. Reproduction in whole or part without prior authorisation from Hepco is prohibited. Although every effort has been made to ensure the accuracy of the information in this catalogue, Hepco cannot accept liability for any omissions or errors. Hepco reserves the right to make alterations to the product resulting from technical developments. Many Hepco products are protected by: Patents, Copyright, Design Right or Registered Design. Infringement is strictly prohibited and may be challenged in law. The Customer's attention is drawn to the following clause in Hepco's conditions of sale: 'It shall be the Customer's sole responsibility to ensure that goods supplied by Hepco will be suitable or fit for any particular application or purpose of the Customer, whether or not such application or purpose is known to Hepco. The Customer will be solely responsible for any errors in, or omissions from, any specifications or information the Customer provides. Hepco will not be obliged to verify whether any such specifications or information are correct or sufficient for any application or purpose.' Hepco's full conditions of sale are available on request and will apply to all quotations and contracts for the supply of items detailed in this catalogue. HepcoMotion is the trading name of Hepco Slide Systems Ltd.



GV3 - SimpleSelect®
Linear Guidance and Transmission System



HDS2
Heavy Duty Slide System

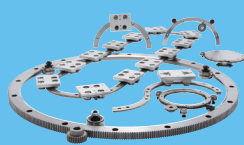

PRT2
Ring Slides and Track System



HDRT
Heavy Duty Ring Slides and Track System



SL2
Stainless Steel Based Slide System

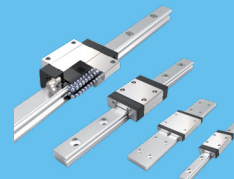

HLG
Hepco Ball Guides

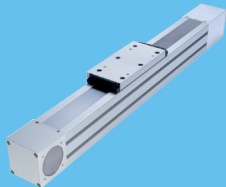

SBD
Sealed Belt Drive

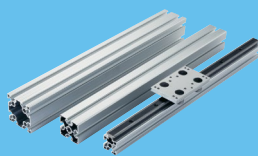

MCS
Aluminium Frame and Machine Construction System

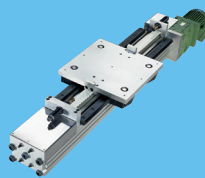

HDLS
Heavy Duty Driven Linear System



DLS
Linear Transmission and Positioning System

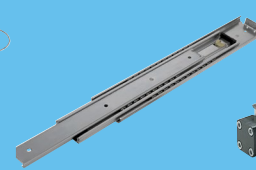

HTS
Telescopic Ball Bearing Slides



HPS
Powerslide-2 Guided Rodless Cylinder

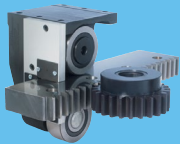

MHD
Heavy Duty Track Roller Guidance System

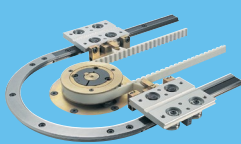

DTS
Driven Track System



Hepco Ball Screws

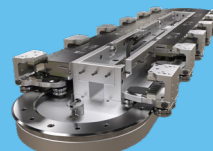

GFX
Guidance for Beckhoff XTS



PDU2
Profile Driven Unit

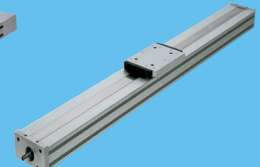

PSD120
Profile Screw Driven Unit



Shaft
Precision Steel and Aluminium Shaft

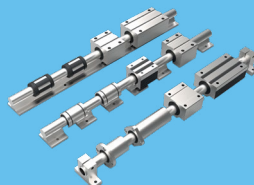

Ball Bushings
Linear Bearing System

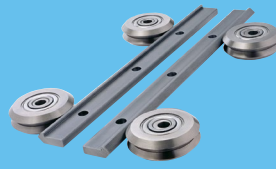

DUALVEE®
Single Edge Slide System

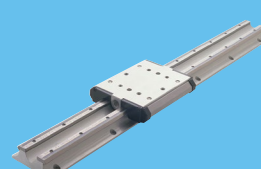

LoPro®
Aluminium Based Slide System



UtiliTrak®
Lightweight U Channel Guideway

For further information on HepcoMotion® products and details of worldwide representation, please visit:

HepcoMotion.com

HepcoMotion
Group Headquarters
www.hepcotion.com
Lower Moor Business Park
Tiverton Way, Tiverton
EX16 6TG
England

Tel: +44 (0)1884 257000
E-mail: sales@hepcotion.com

HepcoMotion Germany
(Also covering Austria &
German-speaking Switzerland)
www.hepcotion.com/de
Tel: +49 (0) 9128 92710
Email: info.de@hepcotion.com

HepcoMotion Spain
www.hepcotion.com/es
Tel: +34 93 607 22 55
Email: info.es@hepcotion.com

HepcoMotion France
(Also covering
French-speaking Switzerland)
www.hepcotion.com/fr
Tel: +33 (0) 1 34 64 30 44
Email: info.fr@hepcotion.com

HepcoMotion South Korea
www.hepcotion.co.kr
Tel: +82 (0) 31 352 7783
Email: sales.korea@hepcotion.com

HepcoMotion Benelux
(Covering Belgium,
Luxembourg & Netherlands)
www.hepcotion.com/nl
Tel: +31 (0) 492 551290
Email: info.nl@hepcotion.com

HepcoMotion China
www.hepcotion.com.cn
Tel: +86 21 5648 9055
Email: sales.china@hepcotion.com



Certification Number 14479
ISO 9001