

Documentation | EN

PS2001-2405-0000

Power supply 24 V DC, 5 A, 1-phase, AC 100-240 V



Table of contents

1 Overview	5
2 Foreword	6
2.1 Notes on the documentation	6
2.2 Safety instructions	7
2.3 Terminology and abbreviations	10
3 Technical data, mounting, wiring	11
3.1 AC input	11
3.2 DC input	13
3.3 Input inrush current	14
3.4 Output	15
3.5 Hold-up time	16
3.6 DC-OK relay contact	17
3.7 Efficiency and losses	18
3.8 Lifetime expectancy	19
3.9 MTBF	19
3.10 Terminals and wiring	20
3.11 Functional wiring diagram	21
3.12 Front side and operating elements	22
3.13 EMC	23
3.14 Environment	24
3.15 Protective functions	25
3.16 Safety features	25
3.17 Dielectric strength	26
3.18 Declaration of conformity and approvals	27
3.19 Dimensions and weight	28
4 Application notes	29
4.1 Peak current capability	29
4.2 Charging batteries	30
4.3 Series connection	31
4.4 Parallel use to increase power	32
4.5 Parallel use for redundancy	33
4.5.1 1+1 Redundancy	33
4.5.2 N+1 Redundancy	34
4.6 Operation on two phases	35
4.7 Use in a tightly sealed enclosure	35
4.8 Installation positions	35
5 Disposal	37
6 Appendix	38
6.1 Accessories	38
6.1.1 Redundancy and buffer modules	38
6.1.2 UPS- component	39
6.1.3 Accessories for mounting	40
6.2 Documentation issue status	41

6.3 Support and Service..... 42

1 Overview

PS2001-2405-0000 | Power supply 24V, 5A, 1 phase, Extra Power



- AC 100-240V wide-range input
- Width only 32mm
- Efficiency of up to 94.3%
- Excellent part-load efficiency
- 120% peak power, 144W
- Precise triggering of fuses through high overload / peak current
- Safe hiccup overload mode
- Active Power Factor Correction (PFC)
- Minimum inrush current surge
- Full output between -25°C and +60°C
- DC-OK relay contact

The power supply PS2001-2405-0000 is a single-phase, 24 V DC power supply with an output current of 5 A and an output power of 120 W.

On the input side, the device features a wide-range input, active Power Factor Correction (PFC) and inrush current limiting.

The output operates according to the UI characteristic curve and switches to the safe hiccup mode in case of overload/short-circuit. The PS2001-2405-0000 features extra power with a continuous maximum output power of 120% and can precisely trigger fuses with a short peak current.

The power supply unit is part of the PS2000 family and has a width of 32 mm. A DC-OK LED and a potential-free relay contact monitor the status of the output voltage. The power supply unit has ATEX, IECEx and Class I Div2 approval as well as SEMI-F47 certification to meet the requirements of the semiconductor industry.

Overview of technical data *)

Overview of technical data	PS2001-2405-0000
Output voltage	DC 24V (Nominal factory setting 24.1V)
Adjustment range	24 - 28V
Output current	6.0-5.1A (amb. below +45°C) 5.0-4.3A (amb. at +60°C) 3.8-3.2A (amb. at +70°C) Linear load reduction between +45°C and +70°C
Input voltage AC	AC 100-240V -15%/+10%
Mains frequency	50-60Hz ±6%
Input current AC	1.09 / 0.6A at 120 / 230Vac
Input voltage DC	DC 110-150V ±20%
Efficiency	93.6 / 94.3% at 120 / 230Vac
Temperature range	-25°C to +70°C
Size (W x H x D)	32 x 124 x 102mm (without DIN rail)
Weight	440 g
Approvals/markings	CE, EAC, UKCA cULus Class I Div2 ATEX/IECEX SEMI F47

*) All values typical for 24V, 5A, 230Vac, 50Hz, +25°C ambient temperature and after a warm-up period of five minutes, unless otherwise stated.

2 Foreword

2.1 Notes on the documentation

Copyright

© Beckhoff Automation GmbH & Co. KG, Germany.

The reproduction, distribution and utilization of this document as well as the communication of its contents to others without express authorization are prohibited.

Offenders will be held liable for the payment of damages. All rights reserved in the event of the grant of a patent, utility model or design.

Disclaimer

The documentation has been prepared with care. The products described are, however, constantly under development.

We reserve the right to revise and change the documentation at any time and without prior announcement.

No claims for the modification of products that have already been supplied may be made on the basis of the data, diagrams and descriptions in this documentation.

Trademarks

Beckhoff®, TwinCAT®, TwinCAT/BSD®, TC/BSD®, EtherCAT®, EtherCAT G®, EtherCAT G10®, EtherCAT P®, Safety over EtherCAT®, TwinSAFE®, XFC®, XTS® and XPlanar® are registered trademarks of and licensed by Beckhoff Automation GmbH. Other designations used in this publication may be trademarks whose use by third parties for their own purposes could violate the rights of the owners.

Patent Pending

The EtherCAT Technology is covered, including but not limited to the following patent applications and patents: EP1590927, EP1789857, EP1456722, EP2137893, DE102015105702 with corresponding applications or registrations in various other countries.

Intended audience

This description is only intended for the use of trained specialists in control and automation engineering who are familiar with the applicable national standards.

It is essential that the documentation and the following notes and explanations are followed when installing and commissioning these components.

The qualified personnel is obliged to always use the currently valid documentation.

The responsible staff must ensure that the application or use of the products described satisfy all the requirements for safety, including all the relevant laws, regulations, guidelines and standards.

2.2 Safety instructions

Description of instructions

In this documentation the following instructions are used.
These instructions must be read carefully and followed without fail!

DANGER

Serious risk of injury!

Failure to follow this safety instruction directly endangers the life and health of persons.

WARNING

Risk of injury!

Failure to follow this safety instruction endangers the life and health of persons.

CAUTION

Personal injuries!

Failure to follow this safety instruction can lead to injuries to persons.

NOTICE

Damage to environment/equipment or data loss

Failure to follow this instruction can lead to environmental damage, equipment damage or data loss.



Tip or pointer

This symbol indicates information that contributes to better understanding.

Intended use

This device is designed for installation in a housing and is intended for general professional use, for example in industrial control systems or office, communication and measuring equipment.

Do not use this power supply in installations where a malfunction could cause serious injury or danger to human life.

If this device is used in a manner that is outside its specifications, the protection provided by the device may be impaired.

Exclusion of liability

All the components are supplied in particular hardware and software configurations appropriate for the application. Modifications to hardware or software configurations other than those described in the documentation are not permitted, and nullify the liability of Beckhoff Automation GmbH & Co. KG.

Personnel qualification

This description is only intended for trained specialists in control, automation and drive engineering who are familiar with the applicable national standards.

Safety regulations

Please note the following safety instructions and explanations!

Product-specific safety instructions can be found on following pages or in the areas mounting, wiring, commissioning etc.

Safety instructions and installation requirements for PS2001-2405-0000 power supply unit**⚠ DANGER****Danger of electric shock, fire, injuries, injuries resulting in death!**

- Do not use the power supply without proper earthing (protective conductor). Use the terminal at the input terminal strip for the earth connection, not one of the screws on the housing.
- Switch off the power supply before working on the device. Provide protection against unintentional reconnection.
- Ensure proper wiring by following all local and national regulations.
- Do not modify or attempt to repair the device.
- Do not open the device, as high voltages are present inside.
- Avoid foreign bodies entering the housing.
- Do not use the device in damp locations or in areas where moisture or condensation is likely to occur.
- Do not touch the device when it is switched on or immediately after it has been switched off. Hot surfaces can cause burns.

⚠ WARNING**Explosion hazard warning!**

Use only in standard vertical mounting orientation with the input terminals at the bottom of the device.

Replacement of components may affect the suitability for this environment.

Do not disconnect the device from the mains and do not operate the voltage adjustment unless the power is switched off or the environment can be considered safe.

For the end product a suitable housing must be provided, which has a minimum protection class of IP54 and meets the requirements of EN 60079-0.

NOTICE**Instructions for use in potentially explosive atmospheres**

The device is suitable for use in the following areas:

Class I Division 2 Groups A, B, C, D

and for use in Group II environments of Category 3 (Zone 2).



Classification:

ATEX: EPS 19 ATEX 1 201 X, II 3G EX ec nC IIC T4 Gc / IECEx EPS 20.0045X.

i Further notes on installation requirements

- This device contains no parts that require maintenance. If an internal fuse trips, this is due to an internal defect.
 - If any damage or malfunction occurs during installation or operation, turn off the power immediately and return the device to the factory for inspection.
 - Install the device on a DIN rail according to EN 60715, with the input terminals at the bottom of the device. Other mounting positions require a reduction of the output current.
 - Make sure that the wiring is correct. Make sure that all individual wires of a strand enter the terminal connection.
 - Use ferrules for wires at the input terminals. Unused screw terminals should be tightened firmly.
 - The device is designed for areas with contamination level 2 in controlled environments. No condensation or frost is allowed.
 - The device housing offers IP20 protection.
 - The device insulation is designed to withstand pulse voltages of overvoltage category III according to IEC 60664-1.
 - The device is designed to meet the requirements of protection class I according to IEC 61140. Do not use the device without a proper PE connection (protective earth).
 - The device is suitable for supply from TN, TT or IT networks. The continuous voltage between the input terminal and the PE potential must not exceed 300Vac.
 - The input can also be powered from batteries or similar DC power sources. The continuous voltage between the supply voltage and the PE/ground potential must not exceed 360Vdc.
 - An isolating device must be provided for the device input.
 - This device is designed for convection cooling and does not require an external fan. Do not obstruct the air circulation. No more than 15% of the ventilation grille may be covered (e.g. by cable ducts)!
 - The device is designed for altitudes up to 5000m (16400ft). Above 2000m (6560ft) a reduction of the output current and overvoltage category is required.
 - Maintain the following installation distances: 40 mm at the top, 20 mm at the bottom and 5 mm on the left and right are recommended if the device continuously runs at more than 50% of the rated output. Increase this distance to 15 mm if the adjacent device is a heat source (e.g. another power supply unit). If the device continuously runs at less than 50%, the 5 mm distance can be reduced to zero.
 - The device is designed, tested and approved for branch-circuit currents up to 32 A (IEC) and 30 A (UL) without additional protection. If an external fuse is used, do not use circuit breakers smaller than 6A (B or C characteristic) to avoid unwanted tripping of the circuit breaker.
 - The maximum ambient air temperature is +70°C (+158°F). The operating temperature corresponds to the ambient or ambient air temperature, per definition at 2 cm below the device.
 - The device is designed for operation in the relative humidity range between 5% and 95%.
-

2.3 Terminology and abbreviations

PE and the earthing symbol 	PE is the abbreviation for "protective earth" and has the same meaning as the earthing symbol 
Earth, ground	This document uses the term "earth" which is the same as the U.S. term "ground".
T.b.d.	Still to be defined, value or description will follow in due course.
AC 230 V	A value preceded by "AC" or "DC" represents a nominal voltage or a nominal voltage range. The nominal voltage or the nominal voltage range may be provided with tolerances. (e.g. AC 230 V \pm 10%). The calculated total range then indicates the working range of the device. Example: DC 12 V refers to a 12 V battery, regardless of whether it is fully charged (13.7 Vdc) or discharged (10 Vdc).
230 Vac	A value followed by the unit Vac or Vdc is an instantaneous value that does not contain any additional tolerances.
50 Hz vs. 60 Hz	Unless otherwise specified, AC 100 V and AC 230 V parameters are valid at a mains frequency of 50 Hz. AC 120 V parameters are valid for a mains frequency of 60 Hz.
may	A keyword indicating a choice without implied preference.
shall	A keyword indicating a mandatory requirement.
should	A keyword indicating a choice with a clearly preferred method of implementation.

3 Technical data, mounting, wiring

3.1 AC input

AC input			
AC input	Nom.	AC 100-240V	Suitable for TN, TT and IT networks
AC input range	Min.	85-264Vac	Continuous operation
	Min.	264-300Vac	For up to 500ms max.
Permissible voltage L or N to earth	Max.	300Vac	Continuous according to IEC 60664-1
Input frequency	Nom.	50-60Hz	±6%
Turn-on voltage	Typ.	80Vac	Static, see Fig. <i>Input voltage range; switch-on behavior definitions</i>
Shut-down voltage	Typ.	74Vac	Static, see Fig. <i>Input voltage range; switch-on behavior definitions</i>

AC input		AC100V	AC120V	AC230V	
Input current	Typ.	1.30A	1.09A	0.60A	At 24 V, 5 A, see Fig. <i>Input current over output current; power factor over output current</i>
Power factor*)	Typ.	0.99	0.98	0.91	At 24 V, 5 A, see Fig. <i>Input current over output current; power factor over output current</i>
Peak factor**)	Typ.	1.7	1.8	2.2	At 24V, 5A
Start-up delay	Typ.	420ms	380ms	385ms	See Fig. <i>Input voltage range; switch-on behavior definitions</i>
Rise time	Typ.	80ms	80ms	80ms	At 24 V, 5 A constant current load, 0 mF load capacity, see Fig. <i>Input voltage range; switch-on behavior definitions</i>
	Typ.	100ms	100ms	10ms	At 24 V, 5 A constant current load, 5 mF load capacity, see Fig. <i>Input voltage range; switch-on behavior definitions</i>
Turn-on overshoot	Max.	200 mV	200 mV	200 mV	See Fig. <i>Input voltage range; switch-on behavior definitions</i>

*) The power factor is the ratio of real (or active) power to apparent power in an AC circuit.

***) The peak factor is the mathematical ratio of the peak value to the RMS value of the input current waveform.

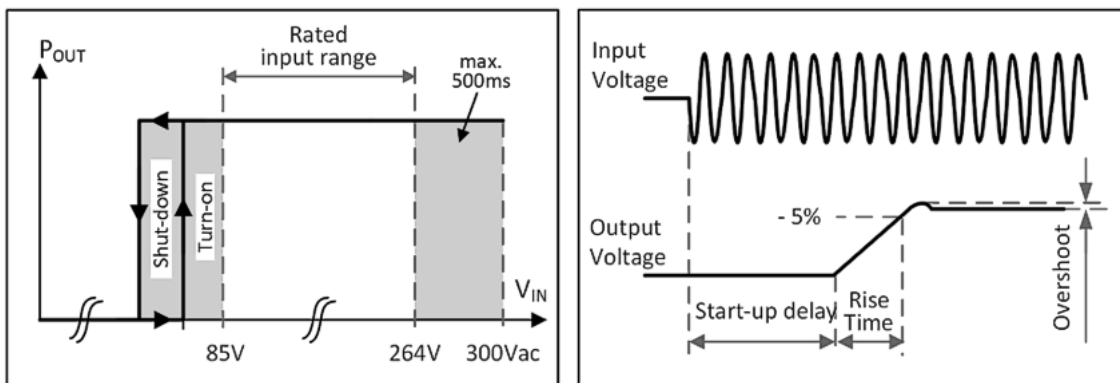

Fig. 1: Input voltage range; switch-on behavior definitions

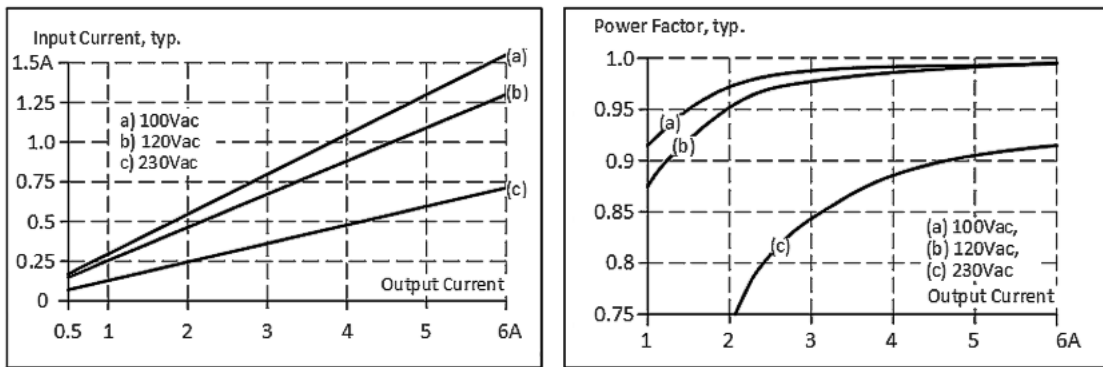

Fig. 2: Input current over output current; power factor over output current

3.2 DC input

DC input			
DC input	Nom.	DC 110-150V	±20%
DC input range	Min.	88-180Vdc	Continuous operation
DC input current	Typ.	1.21A	at 110Vdc, at 24V, 5A
DC input current	Typ.	0.43A	at 300Vdc, at 24V, 5A
Permissible voltage L or N to earth	Max.	360 Vdc	Continuous according to IEC 60644-1
Turn-on voltage	Typ.	74 Vdc	static
Shut-down voltage	Typ.	67 Vdc	static

Instructions for DC operation

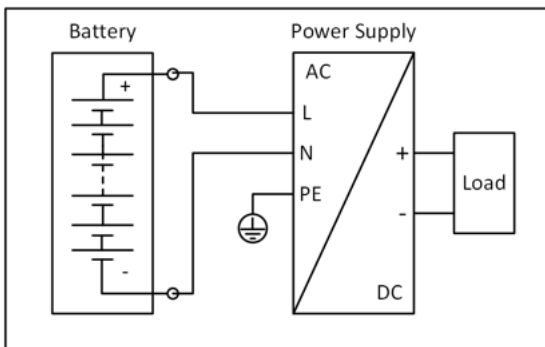

Fig. 3: Wiring for DC input

- Use a battery or a comparable DC source. Operation on the DC link of frequency converters is not recommended and may lead to defects or malfunctions.
- Connect the positive pole to L and the negative pole to N.
- Connect the PE terminal to the protective conductor or machine ground.

3.3 Input inrush current

Active inrush current limitation (NTCs that are bridged by a relay contact) limits the inrush current after the input voltage is switched on.

The charge current of the interference suppression capacitors during the first few microseconds after switching on is not taken into account.

		AC 100V	AC 120V	AC 230V	
Input inrush current	Max.	8A _{peak}	7A _{peak}	7A _{peak}	At +40°C, cold start
	Typ.	5A _{peak}	4A _{peak}	4A _{peak}	At +25°C, cold start
	Typ.	5A _{peak}	5A _{peak}	6A _{peak}	At +40°C, cold start
Switch-on energy	Max.	0.4A ² s	0.5A ² s	1A ² s	At +40°C, cold start

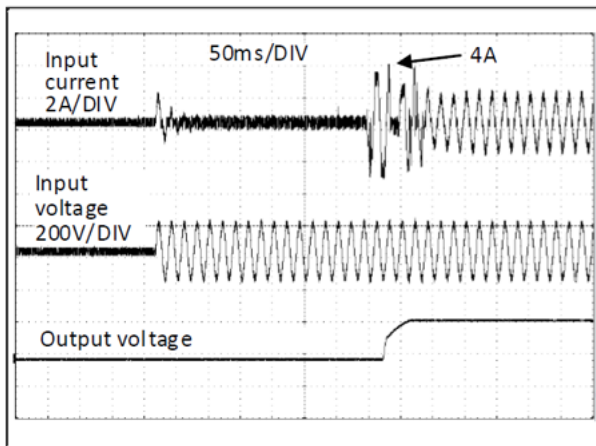

Fig. 4: Typical switch-on behavior at nominal load, 120Vac input voltage and 25°C ambient temperature

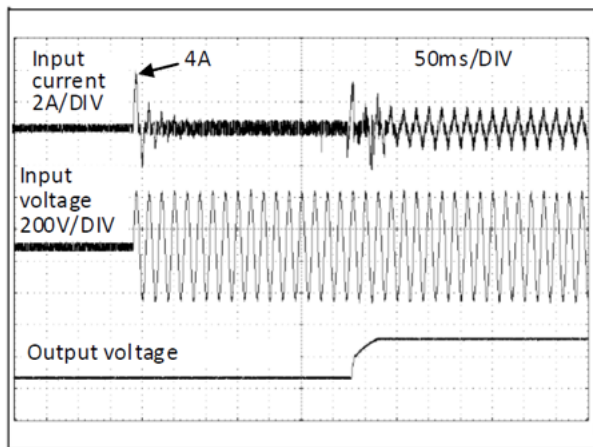

Fig. 5: Typical switch-on behavior at nominal load, 230Vac input voltage and 25°C ambient temperature

3.4 Output

The output provides an SELV/PELV nominal voltage that is electrically isolated from the input voltage.

The output is designed to supply any type of load, including capacitive and inductive loads. If very large capacitors, such as EDLCs (electrical double-layer capacitors or "UltraCaps") with a capacitance > 0.3F are connected to the output, the device can charge the capacitor intermittently.

The output is electronically protected against overload, no-load and short circuit. In the event of a protection event, audible noises may occur.

Output voltage	Nom.	24V	
Adjustment range	Min.	24-28V	Guaranteed value
	Max.	30.0V	This is the maximum output voltage that can occur in the end position of the potentiometer in clockwise direction due to tolerances. It is not a guaranteed value that can be achieved.
Factory settings	Typ.	24.1V	±0.2% at full load (cold device)
Line regulation	Max.	10 mV	Between 85 and 300Vac
Load regulation	Max.	50 mV	Between 0 and 6A, static value, see Fig. <i>Output voltage over output current, typ.</i>
Residual ripple and ripple voltage	Max.	50mV _{ss}	Load >0.2A, bandwidth 20Hz to 20MHz, 50Ohm
	Max.	200mV _{ss}	Load <0.2A, bandwidth 20Hz to 20MHz, 50Ohm
Output current	Nom.	6A ¹⁾	At 24V and an ambient temperature below 45°C, see Fig. <i>Output current over ambient temperature</i>
	Nom.	5A	At 24V and 60°C ambient temperature, see Fig. <i>Output voltage over output current, typ.</i>
	Nom.	3.8A	At 24V and 70°C ambient temperature, see Fig. <i>Output current over ambient temperature</i>
	Nom.	5.1 A ¹⁾	At 28V and an ambient temperature below 45°C, see Fig. <i>Output current over ambient temperature</i>
	Nom.	4.3A	At 28V and 60°C ambient temperature, see Fig. <i>Output voltage over output current, typ.</i>
	Nom.	3.2A	At 28V and 70°C ambient temperature, see Fig. <i>Output current over ambient temperature</i>
Safety switch-off current	Typ.	15A	For at least 12ms once every five seconds, see Fig. <i>Dynamic output current capacity, typ.</i> The fuse switch-off current is an increased transient current that contributes to the tripping of fuses on faulty output branches. The output voltage remains above 20V.
Overload behavior		Continuous current	Output voltage > 13Vdc, see Fig. <i>Output voltage over output current, typ.</i>
		Hiccup mode ²⁾	Output voltage < 13Vdc, see Fig. <i>Output voltage over output current, typ.</i>
Short circuit current	Max.	7.2A	Continuous current, see Fig. <i>Output voltage over output current, typ.</i>
	Typ.	9A	Intermittent current peak value for typ. 1s Load impedance 50mOhm, see Fig. <i>Short circuit at the output,</i> The discharge current of the output capacitors is not included.
	Max.	3.5A	RMS value of current, load impedance 50mOhm, see Fig. <i>Short-circuit at output</i>
Output capacity	Typ.	1800µF	Included in the power supply
Load feedback	Max.	35V	The device is resistant to load feedback and will not indicate a malfunction if a load is feeding voltage back into the power supply. It does not matter whether the power supply is switched on or off. The absorbed energy can be determined by means of the built-in large-size output capacitor.

¹⁾ Up to +70°C this power / current can be called up for a duty cycle of 10%, i.e. no longer than 1 minute every 10 minutes.

²⁾ In the event of heavy overload (when the output voltage drops below 13V), the power supply provides continuous output current for 1s. The output is then switched off for about 9 seconds before a new switch-on attempt is automatically made. This cycle is repeated as long as the overload persists. After the overload has been rectified, the device will operate normally. See Fig. *Short circuit at output*

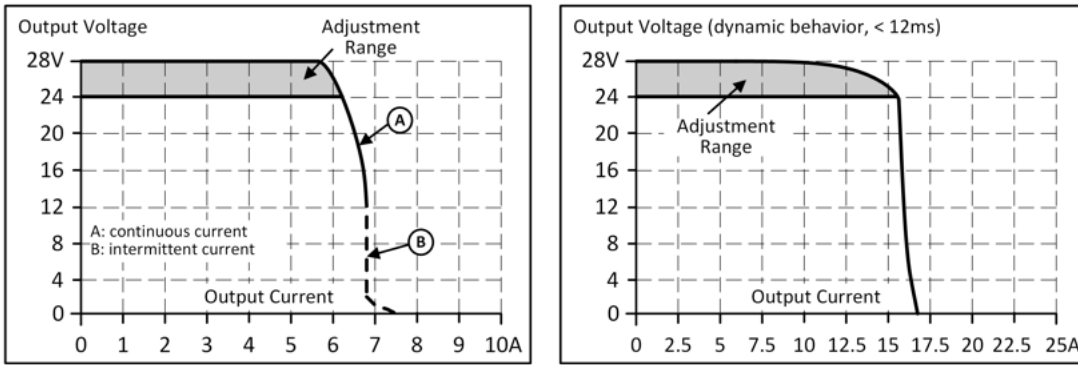

Fig. 6: Output voltage over output current, typ.; Dynamic output current capacity, typ.

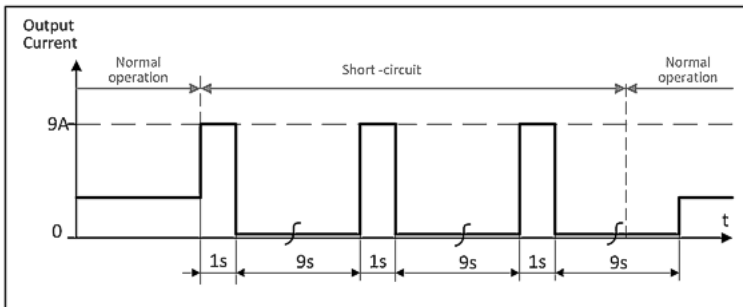

Fig. 7: Short circuit at output, hiccup mode typ.

3.5 Hold-up time

The hold-up time is the time during which the output voltage of a power supply unit remains within the specification after a loss of input power. The hold-up time depends on the output load. At no load the Hold-up time can be up to several seconds. The green DC-OK LED also lights up during this time.

		AC 100V	AC 120V	AC 230V	
Hold-up time	Typ.	70ms	70ms	70ms	At 24V, 2.5A, see Fig. <i>Hold-up time over input voltage</i>
	Min.	55ms	55ms	55ms	At 24V, 2.5A, see Fig. <i>Hold-up time over input voltage</i>
	Typ.	35ms	35ms	35ms	At 24V, 5A, see Fig. <i>Hold-up time over input voltage</i>
	Min.	27ms	27ms	27ms	At 24V, 5A, see Fig. <i>Hold-up time over input voltage</i>

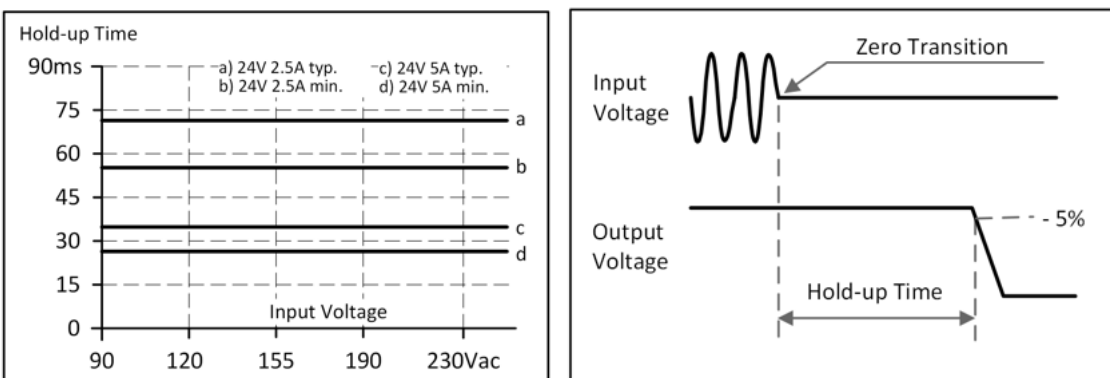

Fig. 8: Hold-up time over input voltage; switch-off behavior, definitions

3.6 DC-OK relay contact

This feature monitors the output voltage at the output terminals of an active power supply.

The contact closes	when the output voltage typically reaches 90% of the set output voltage.
The contact opens	when the output voltage drops more than 10% below the set output voltage. Short drops are extended to a signal length of 100ms. Drops that are shorter than 1ms are ignored.
Switching hysteresis	0.7 V typ.
Contact load capacity	Maximum 60Vdc 0.3A, 30Vdc 1A, 30Vac 0.5A, ohmic load
	Minimum permissible load: 1mA at 5Vdc
Insulation voltage	See the dielectric strength table in the chapter on Safety features [▶ 25]

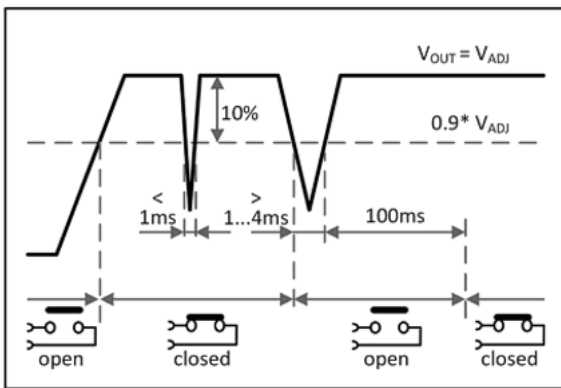

Fig. 9: Behavior of the DC-OK relay contact

3.7 Efficiency and losses

		AC 100V	AC 120V	AC 230V	
Efficiency	Typ.	92.9%	93.6%	94.3%	At 24V, 5A
	Typ.	92.7%	93.5%	94.5%	At 24V, 6A (Extra Power)
Average efficiency ^{*)}	Typ.	91.3%	91.7%	92.0%	25% at 1.25A, 25% at 2.5A, 25% at 3.75A. 25% at 5A
Losses	Typ.	1.3W	1.3W	1.4W	At 24V, 0A
	Typ.	4.6W	4.4W	4.1W	At 24V, 2.5A
	Typ.	9.2W	8.2W	7.3W	At 24V, 5A
	Typ.	11.3W	9.8W	8.4W	At 24V, 6A (Extra Power)

^{*)} The average efficiency is based on assumptions for a typical application with the power supply unit operating at 25% of the nominal load during 25% of the time, 50% of the nominal load during 25% of the time, 75% of the nominal load during 25% of the time and 100% of the nominal load during the remaining time.

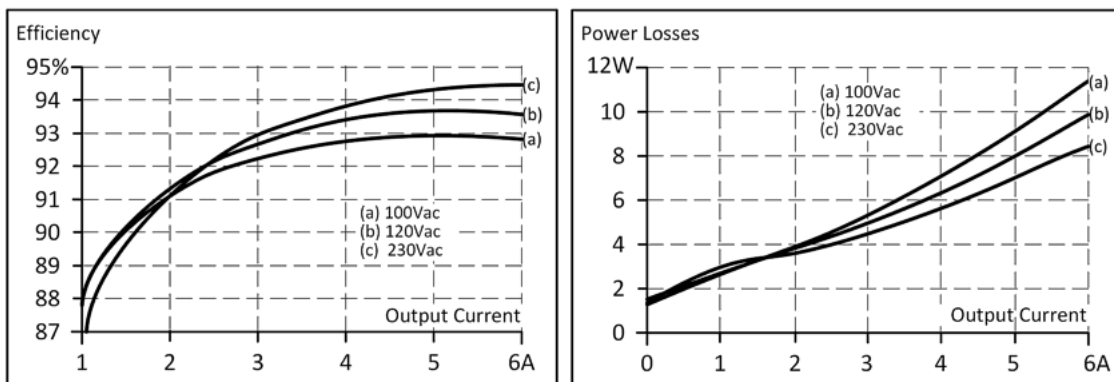

Fig. 10: Efficiency over output current; losses over output current

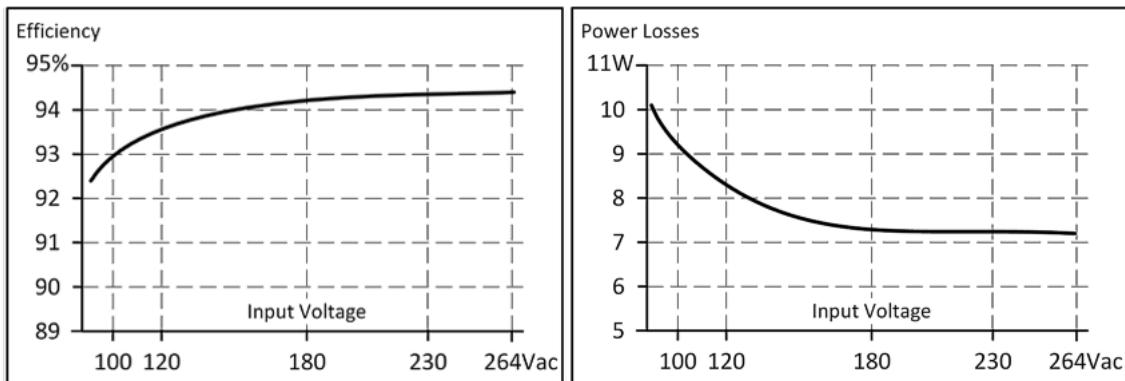

Fig. 11: Efficiency over input voltage; losses over input voltage

3.8 Lifetime expectancy

The lifetime expectancy shown in the table indicates the minimum number of operating hours (service life) and is determined by the lifetime expectancy of the built-in electrolytic capacitors. The lifetime expectancy is stated in operating hours and is calculated according to the specifications of the capacitor manufacturer. The manufacturer of the electrolytic capacitors only guarantees a maximum life of up to 15 years (131,400h). Any number exceeding this value represents a calculated theoretical lifetime which can be used to compare devices.

	AC 100V	AC 120V	AC 230V	
Lifetime expectancy	265,000h	270,000h	274,000h	At 24V, 2.5A and +40°C
	748,000h	764,000h	775,000h	At 24V, 2.5A and +25°C
	128,000h	143,000h	166,000h	At 24V, 5A and +40°C
	363,000h	405,000h	469,000h	At 24V, 5A and +25°C
	81,000h	96,000h	119,000h	At 24V, 6A and +40°C
	228,000h	271,000h	336,000h	At 24V, 6A and +25°C

3.9 MTBF

MTBF stands for **Mean Time Between Failure**, which is calculated from the statistical failure rate of the components and indicates the reliability of a device. It is a statistical representation of the probability of equipment failure and does not necessarily represent the service life of a product.

The MTBF number is a statistical representation of the probability of equipment failure. An MTBF number of 1,000,000h, for example, means that statistically, if there are 10,000 devices in use, one device will fail every 100 hours. However, it is not possible to say whether the failed device has been in operation for 50,000 hours or only 100 hours.

For these device types the MTTF value (**Mean Time To Failure**) is identical to the MTBF value.

	AC 100V	AC 120V	AC 230V	
MTBF SN 29500, IEC 61709	800,000h	807,000h	867,000h	At 24V, 5A and +40°C
	1,402,000h	1,414,000h	1,510,000h	At 24V, 5A and +25°C
MTBF MIL HDBK 217F	339,000h	343,000h	368,000h	At 24V, 5A and +40°C; Ground Benign GB40
	490,000h	496,000h	529,000h	At 24V, 5A and +25°C; Ground Benign GB25
	81,000h	83,000h	89,000h	At 24V, 5A and +40°C; Ground Fixed GF40
	109,000h	111,000h	119,000h	At 24V, 5A and +25°C; Ground Fixed GF25

3.10 Terminals and wiring

The terminals are designed to be finger-safe according to IP20 and are suitable for field or factory wiring.

Technical data	Input	Output	DC-OK signal
Connection cross-section	e*: max. 6mm ² f*: max. 4mm ² a*: max. 4mm ² (d<2.8mm)	e*: max. 6mm ² f*: max. 4mm ² a*: max 4mm ² (d<2.8mm)	e*: max. 1.5mm ² f*: max. 1.5mm ² a*: max. 1.5mm ² (d<1.6mm)
Connection cross section (AWG)	e*: AWG 20-10 f*: AWG 20-10 a* AWG 20-10 (d<2.8mm)	e*: AWG 20-10 f*: AWG 20-10 a* AWG 20-10 (d<2.8mm)	e*: AWG 24-16 f*: AWG 24-16 a*: AWG 24-16 (d<1.6mm)
Strip length	7mm / 0.28inch	7mm / 0.28inch	7mm / 0.28inch

e* = solid single wire
f* = stranded wire
a* = with ferrule

Wiring instructions:

- Use suitable copper cables that are designed for at least the following operating temperatures: +60°C for ambient temperatures up to +45°C, +75°C for ambient temperatures up to +60°C, and +90°C for ambient temperatures up to +70°C.
- Observe the national installation rules and regulations!
- Make sure that all single wires of a strand are connected to the terminal!
- Unused terminals should be tightened firmly.
- Ferrules are permitted.

Series connection of power supply units:

Power supply units may be connected in series.

Series connection (looping from one power supply output to the next) is permitted as long as the average output current flowing through a connection pin does not exceed 25 A. For higher currents please use a separate distributor terminal strip as shown in Fig. *Using distribution terminals*.

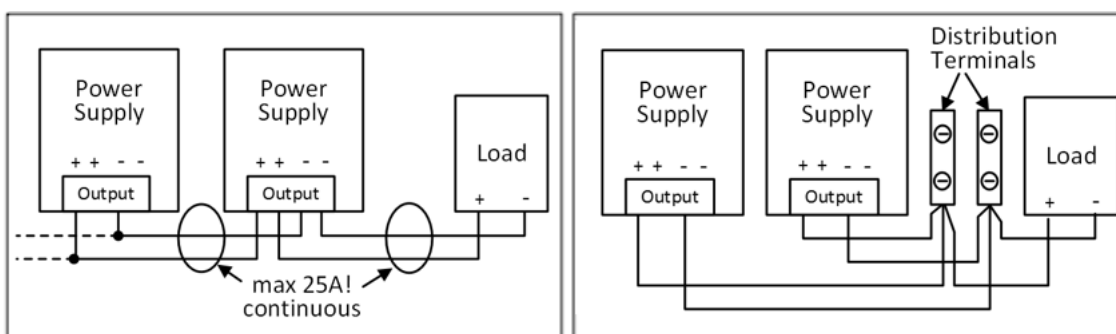

Fig. 12: Series connection of outputs; use of distribution terminals

3.11 Functional wiring diagram

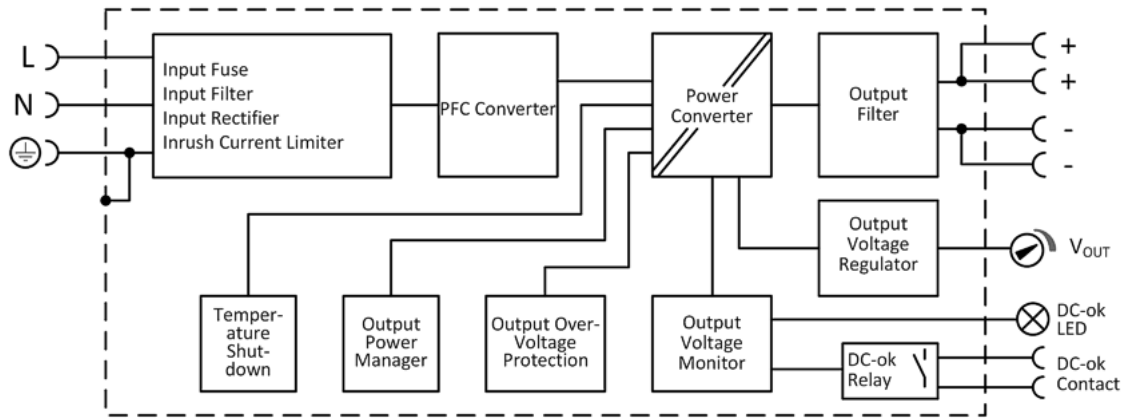



Fig. 13: Functional wiring diagram

3.12 Front side and operating elements



Fig. 14: Front PS2001-2405-0000

Input terminals (screw terminals)

Designation (A)	Description
N	Mains input N
L	Mains input L
	PE input (protective conductor)

Output terminals (screw terminals)

Designation (B)	Description
+	two identical positive poles, positive output
-	two identical negative poles, negative output

Potentiometer for the output voltage

Designation (C)	Description
Potentiometer	Factory setting: 24.1V, adjustable +24V..+28V

DC-OK LED

Designation (D)	Description
LED green	Lights up when the output voltage is within the expected range and the DC OK contact is closed.

DC-OK relay contact

Designation (E)	Description
Push-in terminals 13 / 14	Monitors the output voltage of the active power supply. See chapter on DC OK relay contact [▶ 17] for more information.

3.13 EMC

The power supply is suitable for application in industrial environments as well as in residential, commercial and light industrial areas and small businesses.

The device was tested according to EN 61000-6-1, EN 61000-6-2, EN 61000-6-3 and EN 61000-6-4.

EMC interference immunity			
Strong transients	VDE 0160	Over the entire load range	750V, 0.3ms

EMC interference emission		
Cable-related interference emission, input lines	EN 55011, EN 55015, EN 55022, FCC Part 15, CISPR 11, CISPR 22	Class B
Cable-related interference emission output lines	IEC/CISPR 16-1-2, IEC/CISPR 16-2-1	Limit values for the DC current connection according to EN 61000-6-3 are met
Interference emission	EN 55011, EN 55022	Class B
Harmonic input current	EN 61000-3-2	Class A
Voltage fluctuations, flicker	EN 61000-3-3	Requirements met ¹⁾

This device complies with FCC Part 15.

Operation is subject to the following two conditions: (1) This device may not cause harmful interference, and (2) this device must be able to deal with any interference received, including interference that may cause undesired operation.

Switching frequencies		
PFC converter	30kHz to 140kHz	Input voltage and output load dependent
Main converter	60kHz to 140kHz	Output load dependent
Auxiliary converter	30kHz to 60kHz	Output load dependent

3.14 Environment

Environment		
Operating temperature ¹⁾	-25°C to +70°C	Reduction of the output power according to Fig. <i>Output current over ambient temperature</i>
Storage temperature	-40°C to +85°C	For storage and transport
Output load reduction (derating)	1.6W/°C 3W/°C	+45°C to +60°C / +60°C to +70°C
	0.33A/1000m or 5°C/1000m	For altitudes >2000m (6560ft), see Fig. <i>Output current over installation altitude</i>
	The derating is not hardware-controlled. The user must take this into account in order to stay below the reduced current limits, so that device overload is avoided.	
Moisture	5 to 95% r.h.	According to IEC 60068-2-30 Do not energize if there is condensation.
Oscillation, sinusoidal ²⁾	2–17.8Hz: ±1.6mm; 17.8-500Hz: 2g 2 hours/axis	According to IEC 60068-2-6
Impacts ²⁾	30g 6ms, 20g 11ms 3 impacts / direction, 18 impacts in total	According to IEC 60068-2-27
Atmospheric pressure	110-54kPa	see Fig. <i>Output current over installation altitude</i>
Installation altitude	up to 5000m	see Fig. <i>Output current over installation altitude</i>
Overvoltage category	III	According to IEC 60664 -1, installation altitudes up to 2000m
	II	According to IEC 60664 -1, installation altitudes above 2000m
Degree of pollution	2	According to IEC 62477-1, non-conductive
LABS-free	The device does not release any silicones or other paint-wetting impairment substances and is suitable for use in paint shops.	
Corrosive gas	Tested according to ISA-71.04-1985, Severity Level G3, IEC 60068-2-60 Test Ke Method 4 for a service life of at least 10 years in these environments.	
Audible noises	In the event of no-load, overload or short circuit, the power supply unit emits audible noises.	

¹⁾ The working temperature is identical to the room temperature or the ambient temperature and is defined as the air temperature 2cm below the device.

²⁾ Tested in conjunction with DIN rails according to EN 60715 with a height of 15mm and a thickness of 1.3mm and standard mounting position.

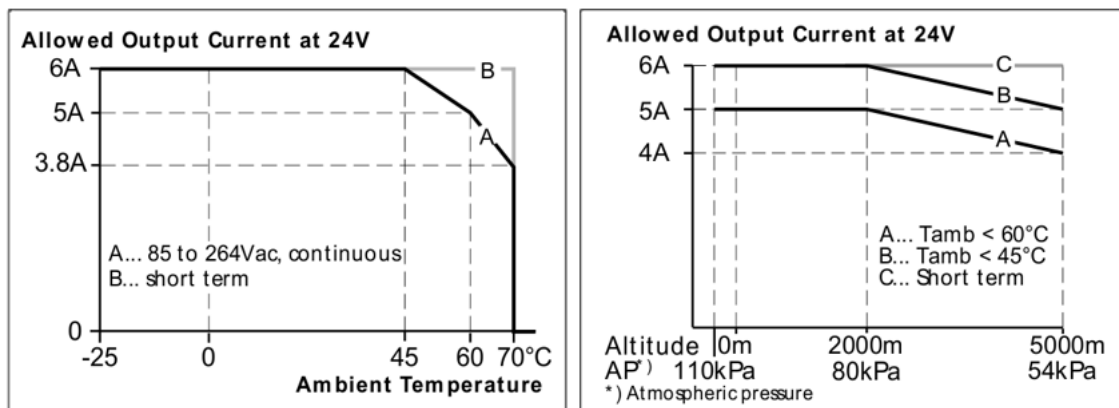

Fig. 15: Output current over ambient temperature; output current over installation altitude

3.15 Protective functions

Protective functions		
Output overvoltage protection	Typ. 30.5Vdc Max. 32Vdc	In the event of an internal power supply fault, a redundant circuit limits the maximum output voltage. The output switches off and automatically tries to switch on again.
Protection class	IP 20	EN/IEC 60529
Overtemperature protection	Yes	Output shutdown with automatic restart. The temperature sensor is installed at critical components within the device and switches off the device in safety-critical situations (e.g. load reduction requirements not met, excessive ambient temperature, ventilation blocked or load reduction not observed if the mounting direction is different). There is no correlation between the operating temperature and the switch-off temperature, since the latter depends on the input voltage, the load and the installation type.
Protection against input transients	MOV (metal oxide varistor)	For further information see EMC chapter [▶ 23]
Input fuse	Included	Non-replaceable slow-blow fuse with high load capacity

3.16 Safety features

Safety features		
Protection class	I	According to IEC61140 PE (protective conductor) connection required
Insulation resistance	> 500MΩ	In the delivery state between input and output, measured with 500Vdc
	> 500MΩ	In the delivery state between input and protective conductor, measured with 500Vdc
	> 500MΩ	In the delivery state between output and protective conductor, measured with 500Vdc
	> 500MΩ	In the delivery state between output and DC OK contacts, measured with 500Vdc
PE resistance	< 0.1Ω	Resistance between the protective conductor connection and the housing near the DIN rail mounting bracket.
Leakage current	Typ. 0.10mA / 0.27mA	At 100Vac, 50Hz, TN, TT / IT network
	Typ. 0.13mA / 0.38mA	At 120Vac, 60Hz, TN, TT / IT network
	Typ. 0.20mA / 0.60mA	At 230Vac, 50Hz, TN, TT / IT network
	Max. 0.13mA / 0.35mA	At 110Vac, 50Hz, TN, TT / IT network
	Max. 0.17mA / 0.51mA	At 132Vac, 60Hz, TN, TT / IT network
	Max. 0.27mA / 0.81mA	At 264Vac, 50Hz, TN, TT / IT network

3.17 Dielectric strength

The output voltage is earth-free and has no ohmic connection to earth.
The output is isolated from the input by double or reinforced insulation.

Type and component tests are carried out by the manufacturer. Field tests can be performed in the field using suitable test equipment that ramps up the voltage with a slow ramp (2s rising and 2s falling). Connect all input terminals and all output poles to each other before performing the tests. During the test, set the cut-off current to the value shown in the table below.

We recommend connecting either the positive pole, the negative pole or another part of the output circuit to the protective conductor system. This avoids situations in which the load starts unexpectedly or cannot be disconnected if an unnoticed earth leakage occurs.

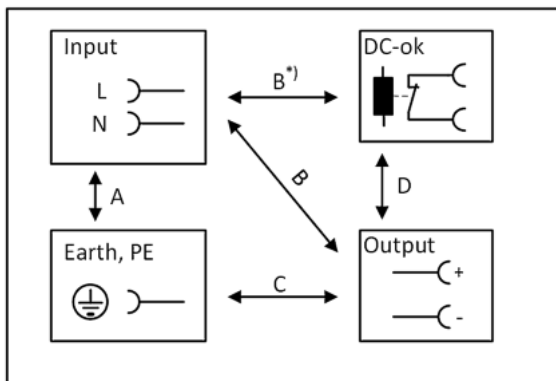









Fig. 16: Dielectric strength

B^{*)} When checking the input to DC-OK, make sure that the maximum voltage between DC-OK and the output is not exceeded (column D). When performing the test, we recommend connecting the DC OK contact pins and the output contact pins.

		A	B	C	D
Type test	60s	2500Vac	3000Vac	1000Vac	500Vac
Component test	5s	2500Vac	2500Vac	500Vac	500Vac
Field test	5s	2000Vac	2000Vac	500Vac	500Vac
Setting the cut-off current		>10mA	> 10mA	> 20mA	> 1mA

3.18 Declaration of conformity and approvals

	<p>EU declaration of conformity</p>
	<p>UK Declaration of Conformity Trade conformity assessment for England, Scotland and Wales The UKCA mark indicates conformity with the UK Statutory Instruments 2016 No. 1101 (LVD) 2016 No. 1091 (EMC) and 2012 No. 3032 (RoHS)</p>
	<p>Registration for the Eurasian Customs Union market (Russia, Kazakhstan and Belarus)</p>
	<p>UL Certificate: UL 61010-1/2-201, Applicable for US and Canada</p>
	<p>UL Certificate: Class I Division 2, Groups A,B,C,D location and for use in Group II, Category 3 (Zone 2) environments Applicable for US and Canada</p>
	<p>Classification: ATEX: EPS 19 ATEX 1 201 X, II 3G EX ec nC IIC T4 Gc</p>
	<p>Classification: IECEx EPS 20.0045X</p>

3.19 Dimensions and weight

Dimensions and weight	
Overall width	32mm
Height	124mm
Depth	102mm The height of the DIN rails must be added to the depth of the device to calculate the total installation depth required
Weight	440 g
DIN rail	Use 35 mm DIN rails according to EN 60715 or EN 50022 with a height of 7.5 or 15mm.
Housing material	Housing: Aluminum alloy Cover: Galvanized steel
Installation clearances	See chapter on Safety instructions and installation requirements [► 9]
Ingress protection	Small parts such as screws, nuts, etc. with a diameter greater than 3.5 mm

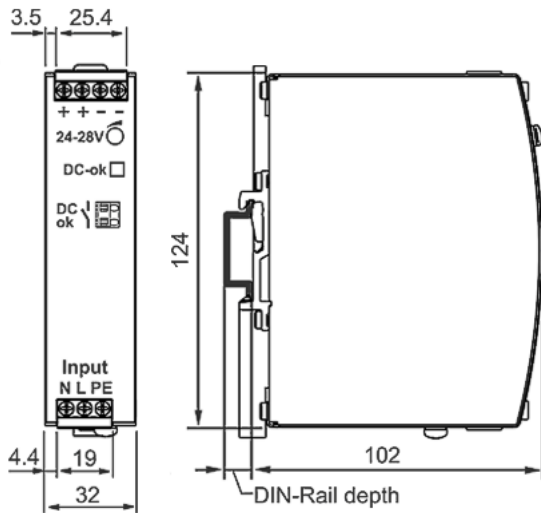

Fig. 17: Front/side view PS2001-2405-0000, all specifications in mm

4 Application notes

4.1 Peak current capability

The device can deliver peak currents (for up to several milliseconds) that are higher than the specified short-term currents.

This helps when starting loads with high current intensity. Magnetic coils, contactors and pneumatic modules often have a stationary coil and a pick-up coil. The inrush current requirement of the pick-up coil is several times higher than the stationary current and usually exceeds the rated output current (including extra power). The situation is exactly the same when starting a capacitive load.

The peak current capability also ensures safe operation of downstream circuit breakers of load circuits. The load circuits are often individually fused with circuit breakers or fuses. In the event of a short circuit or overload in a circuit, the fuse or circuit breaker needs a certain amount of overcurrent to open in time. This prevents a voltage drop in adjacent circuits.

The additional current (peak current) is supplied by the power converter and the built-in large-size output capacitors of the power supply unit. The capacitors are discharged during such an event, which leads to a voltage drop at the output. The following two examples show typical voltage drops for ohmic loads:

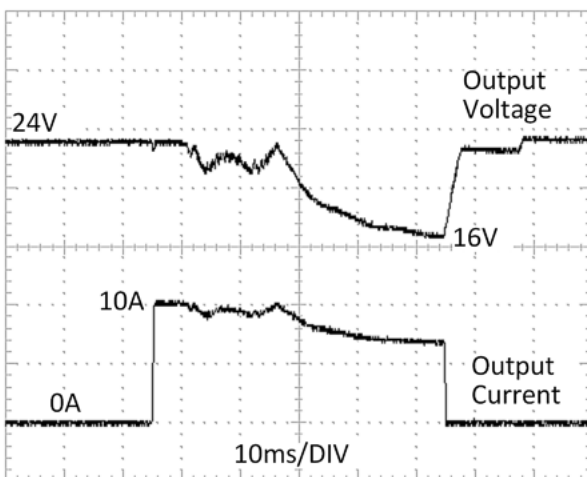

Fig. 18: 10A peak current for 50ms, typ. (2x nominal current)

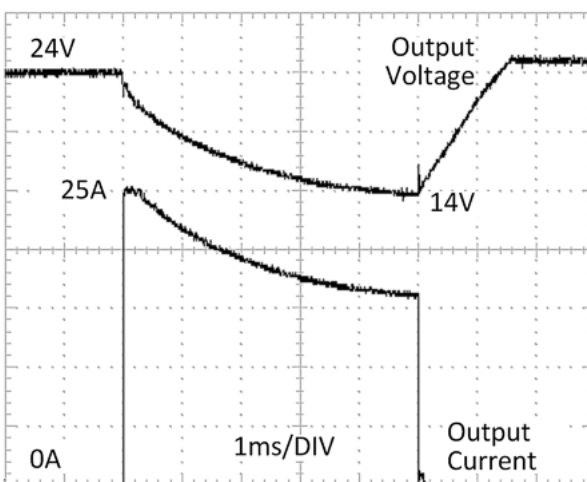

Fig. 19: 25A peak current for 5ms, typ. (5x nominal current)

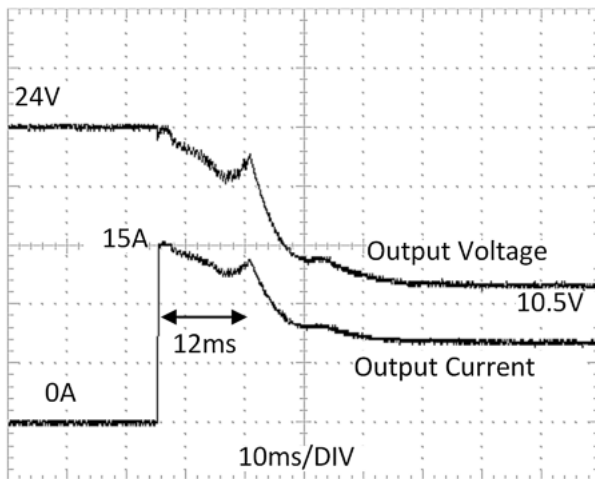

Fig. 20: 15A peak current for 12ms, typ. (3x nominal current)



Control of DC-OK relay

Please note: The DC-OK relay is activated if the voltage drops by more than 10% for more than 1ms.

Peak current voltage drops	
Typically from 24V to 16V	At 10A for 50ms, ohmic load
Typically from 24V to 16.5V	At 25A for 2ms, ohmic load
Typically from 24V to 14V	At 25A for 5ms, ohmic load

4.2 Charging batteries

The power supply can be used to charge lead-acid batteries or maintenance-free batteries (SLA or VRLA batteries). Two 12V batteries connected in series are required.

Instructions for charging batteries:

- Only use matched batteries when connecting 12V types in series.
- Make sure that the ambient temperature of the power supply remains below 40°C.
- Use a 10A protective circuit breaker or a decoupling diode between the power supply and the battery.
- Make sure that the output current of the power supply is below the permissible charging current of the battery.
- The reverse current to the power supply is typically 8mA. This reverse current can discharge the battery when the power supply is switched off, unless a decoupling diode is used.
- Adjust the output voltage, measured at no load and at the battery end of the cable, very precisely to the end-of-charge voltage. The voltage should be set to 27.8V at 10°C, 27.5V at 20°C, 27.15V at 30°C and 26.8V at 40°C ambient temperature.

4.3 Series connection

Power supplies of the same type can be connected in series to increase the output voltages. As many devices can be connected in series as necessary, as long as the sum of the output voltages does not exceed 150 Vdc. Voltages with a potential higher than 60 Vdc are no longer regarded as safety extra-low voltage and can be dangerous. Such voltages must be protected with a touch guard.

Grounding of the output is required if the sum of the output voltage is more than 60 Vdc.

Avoid application of return voltage (e.g. from a braking motor or battery) to the output terminals in a series connection.

Restrictions: Keep a mounting distance of 15 mm (left/right) between two power supplies and do not install the power supplies above each other. Power supplies connected in series should only be used in the standard installation position (terminals on the underside of the device).

Remember that leakage current, electromagnetic interference, inrush current and harmonics increase when using multiple power supplies.

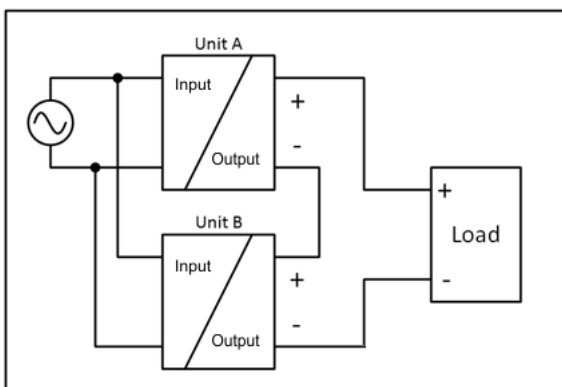

Fig. 21: Series connection

4.4 Parallel use to increase power

PS2001-2405-0000 power supplies can be connected in parallel to increase the output power. The output voltage of all power supplies must be set to the same value ($\pm 100\text{mV}$) and with the same load conditions on all devices, or the factory settings of the devices can be retained. The ambient temperature may not exceed $+40^\circ\text{C}$.

If more than three devices are connected in parallel, a fuse or circuit breaker with a rated current of 10A is required at each output. Alternatively a diode can be used.

Energize all devices simultaneously. It may also be necessary to ramp up and shut down the input power (turn off for at least five seconds) if the output was overloaded or short-circuited and the required output current is higher than the current of a device.

Restrictions: Keep a mounting distance of 15mm (left/right) between two power supplies and do not install the power supplies above each other. In parallel mode power supplies should only be used in the standard installation position (terminals on the underside of the device), not in other installation positions or under other conditions that require a reduction in the output current (e.g. installation altitude ...).

Remember that leakage current, electromagnetic interference, inrush current and harmonics increase when using multiple power supplies.

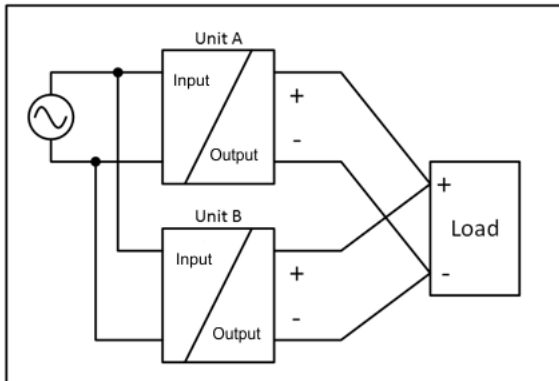

Fig. 22: Parallel connection

4.5 Parallel use for redundancy

Recommendations for the construction of redundant power supply systems:

- Power supplies that contain a DC-OK signal contact are best suited for the construction of redundant power supply systems.
 - Use this DC-OK signal contact to monitor the individual power supplies.
- Use separate grids for each power supply whenever possible.
- It is recommended to set the output voltages of all devices to the same value (± 100 mV) or to leave them at the factory setting.

4.5.1 1+1 Redundancy

It is possible to connect power supplies in parallel for redundancy operation in order to achieve better system availability. Redundant systems provide a certain amount of additional power to operate the load when a power supply unit fails. The simplest method is to connect two power supplies in parallel. This is called 1+1 redundancy. If one power supply fails, the other can automatically supply the load current without interruption.

The 1+1 redundancy allows ambient temperatures up to $+70^{\circ}\text{C}$.

i Notes on parallel use for 1+1 redundancy

- Be sure to use a redundancy module in order to decouple devices from one another. This prevents the defective device from becoming a load for the other device and the output voltage no longer being maintainable.
- Note that leakage current, EMI, input inrush current and harmonics increase when using multiple devices.

Wiring example:

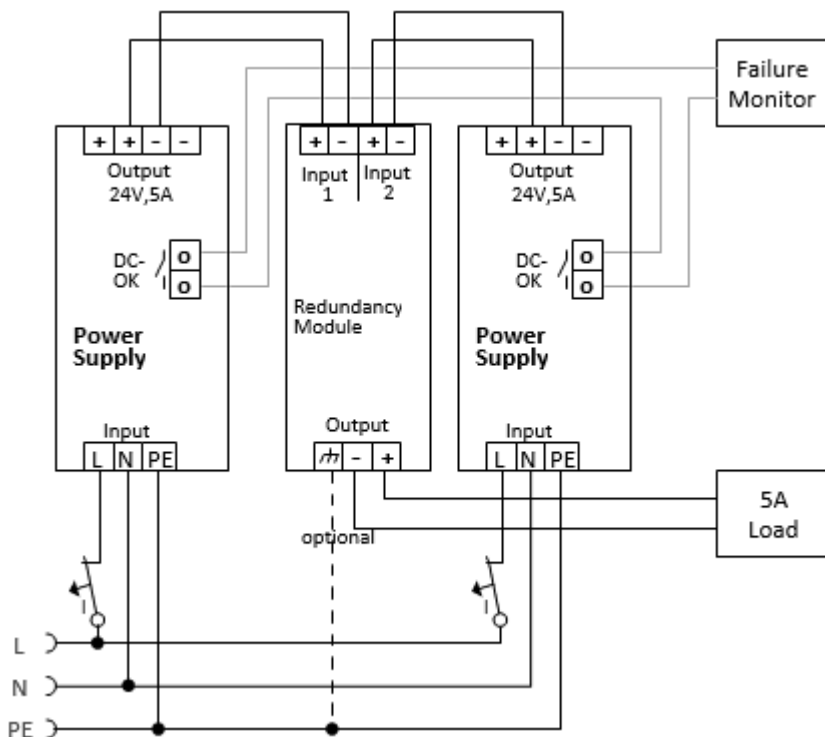

Fig. 23: Wiring for 1+1 - redundancy with one redundancy module PS9401-2420-0000

4.5.2 N+1 Redundancy

Notes on parallel use for N + 1 redundancy

- Note that leakage current, EMI, input inrush current and harmonics increase when using multiple devices.
- The ambient temperature may not exceed +60 °C for N + 1 redundancy systems.

Redundancy systems for higher power requirements are usually set up using the N + 1 method. For example, four devices with a nominal current of 5 A are connected in parallel for a 15 A redundancy system.

- Keep a mounting distance of 15 mm (left/right) between two power supplies.
- Do not install the power supplies above each other.
- Do not use power supplies connected in parallel in an installation position that deviates from the standard installation position (connection terminals on the underside of the device) or in a different state requiring a reduction in the output current.

Wiring example:

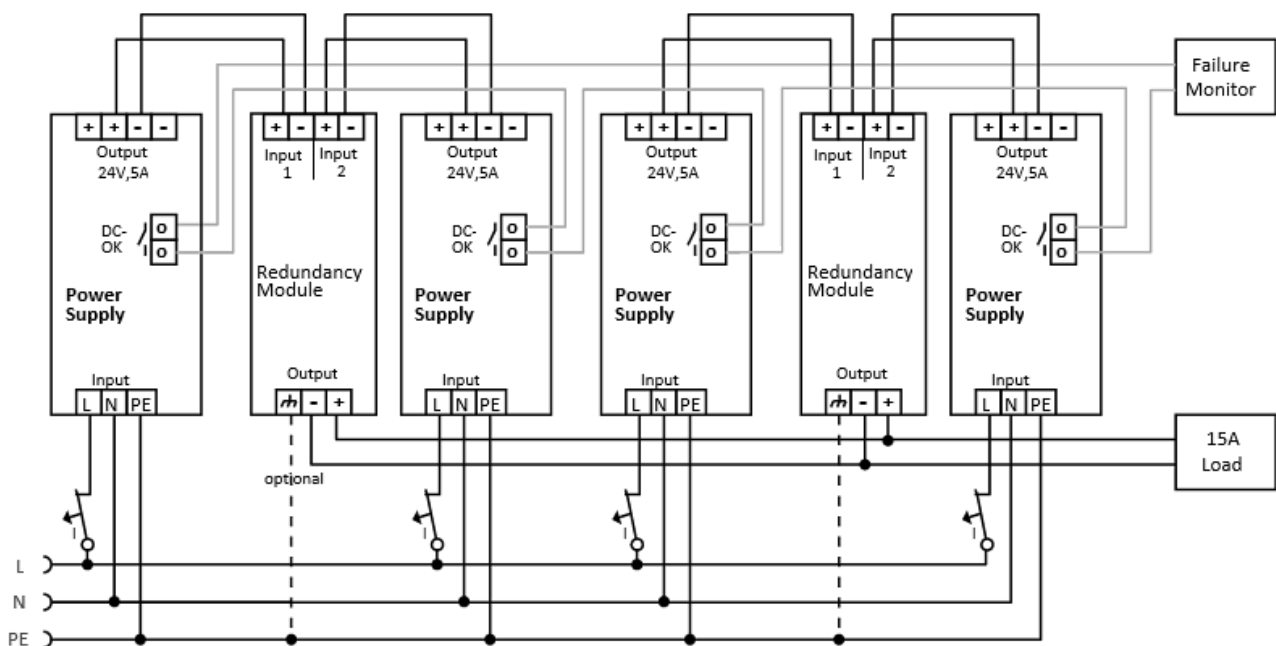

Fig. 24: Wiring for n+1 - redundancy with two redundancy modules PS9401-2420-0000

4.6 Operation on two phases

The power supply can also be used on two phases of a three-phase system. Such a phase-to-phase connection is permissible as long as the supply voltage is below 240V+10%.

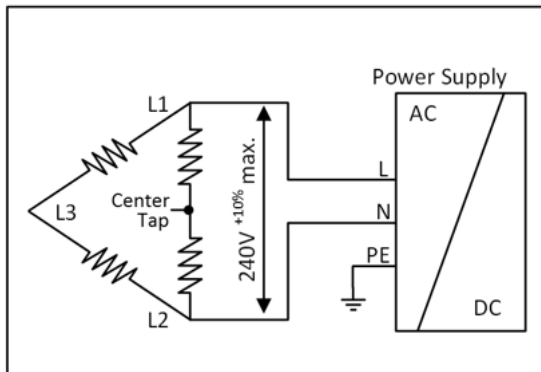

Fig. 25: Operation on two phases

Make sure that the connection cable connected to the N terminal is fused appropriately.

The maximum permissible voltage between one phase and the PE must be below 300Vac.

4.7 Use in a tightly sealed enclosure

When the power supply is installed in a tightly sealed enclosure, the temperature inside the housing is higher than outside. In this case, the temperature inside the housing is considered the ambient temperature for the power supply.

The following measurement results can be used as reference for estimating the temperature rise inside the housing.

The power supply is positioned at the center of the housing. There are no other heat-generating elements in the housing.

The temperature sensor in the housing is positioned at the center on the right side of the power supply with a distance of 1cm.

	Case A	Case B
Housing size	110x180x165mm Rittal housing, protection class IP66 PK 9516 100, plastic	110x180x165mm Rittal housing, protection class IP66 PK 9516 100, plastic
Input voltage	230Vac	230Vac
Load	24V, 4A; (=80%)	24V, 5A; (=100%)
Temperature inside the housing	38.3°C	39.6°C
Temperature outside the housing	26.1°C	25.5°C
Temperature increase	12.2K	14.1K

4.8 Installation positions

Installation positions other than the input connections at the bottom and the output at the top require a reduction of the continuous output power or a limitation of the maximum permissible ambient temperature.

The values for service life and MTBF given in this data sheet are only valid for the standard mounting orientation.

The following curves give an indication of permissible output currents for altitudes up to 2000m.

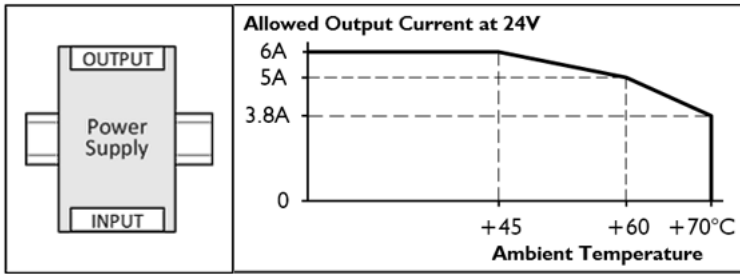

Fig. 26: Mounting position A (standard mounting position)

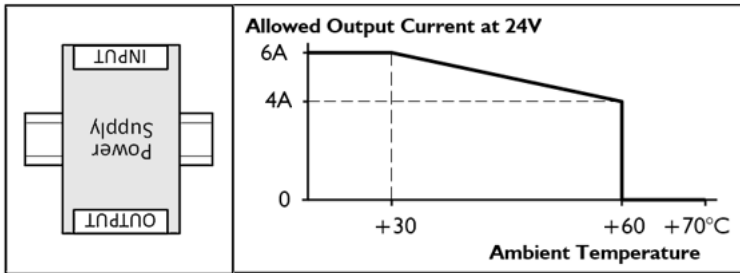

Fig. 27: Mounting position B (upside down)

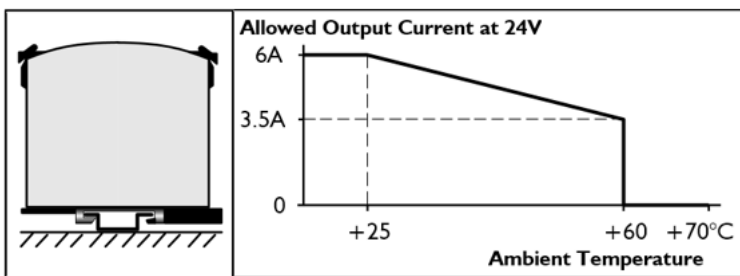

Fig. 28: Mounting position C (table mounting)

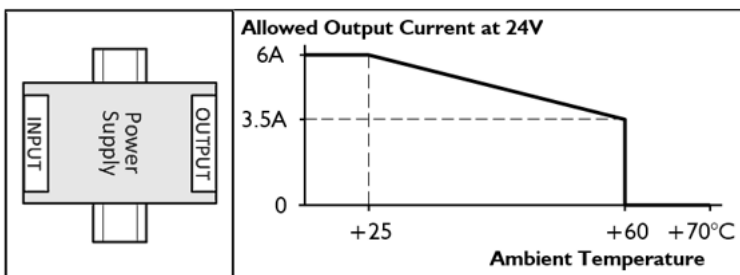

Fig. 29: Mounting position D (horizontal clockwise)

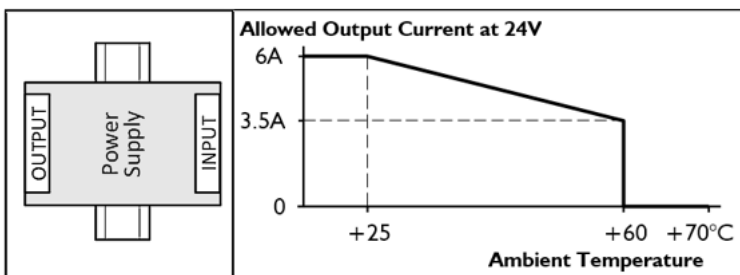

Fig. 30: Mounting position E (horizontal counterclockwise)

5 Disposal



Products marked with a crossed-out wheeled bin shall not be discarded with the normal waste stream. The device is considered as waste electrical and electronic equipment. The national regulations for the disposal of waste electrical and electronic equipment must be observed.

6 Appendix

6.1 Accessories

6.1.1 Redundancy and buffer modules

Power supply	Accessories	
	Redundancy module	Buffer module
PS2001-2405-000	PS9401-2420-0000	PS9011-2420-0001

PS9401-2420-0000 – Redundancy Module



The PS9401-2420-0000 is a redundancy module that can be used to construct 1+1 and N+1 redundant systems.

It has two input channels, to which power supplies with an output current of up to 12 A can be connected, and an output that can carry nominal currents up to 20 A. The output can also be operated with up to 24 A if the ambient temperature is $< +45^{\circ}\text{C}$.

The redundancy module uses MOSFET technology instead of diodes for decoupling the two input channels. This reduces the heat development and the voltage drop between input and output. Due to the low power loss, the device is very narrow and requires a width of just 32 mm on the DIN rail.

Large connection terminals enable secure and fast installation. The redundancy module requires no additional auxiliary voltage.

Due to the international approvals package, the device is suitable for virtually every application.

Observe the connection instructions in the chapter "[Parallel use for redundancy \[p. 33\]](#)"!

PS9011-2420-0001 – Buffer Module



The PS9011-2420-0001 buffer module is an additional device for 24 V DC power supply units. It supplies power to bridge typical mains power failures or extends the hold-up time after switching off the AC voltage.

If the power supply unit supplies sufficient voltage, the buffer module stores energy in the integrated electrolytic capacitors. In the event of a failure of the mains voltage, the stored energy is supplied to the DC bus in a controlled process.

The buffer module can be connected at any point in parallel with the load circuit and does not require any control wiring.

A buffer module can provide 20 A of additional power and can be added in parallel to increase the output current or hold-up time.

The PS9011-2440-0000 buffer module can optionally be used to achieve longer hold-up times.

6.1.2 UPS- component

CU8130-0xxx – UPS component



CU8130-0xxxs are battery-backed, uninterruptible power supplies (UPS). If the external 24 V DC input voltage is lost, the UPS takes over the supply of the devices connected to it thanks to its regulated and buffered 24 V DC output voltage.

The CU81xx UPS series is suitable for all Beckhoff components, particularly Industrial PCs, Embedded PCs, Panels and Panel PCs.

The main features of this UPS are:

- battery module based on NiMH cells
- mounting of the UPS on the DIN rail or on the rear panel of the control cabinet
- protocol-based communication with the Industrial PC either via OCT (**O**ne **C**able **T**echnology) or USB
- digital signals for communication with non-protocol-capable end devices
- TwinCAT PLC function blocks for querying the UPS operation

A special feature of the Beckhoff CU81xx devices is OCT (**O**ne **C**able **T**echnology) as communication technology between UPS and Industrial PC. This means that the two connecting lines (+24 V, 0 V) between Industrial PC and UPS are used not only to supply the Industrial PC, but also for bidirectional data transmission.

If both sides are OCT-capable, no further connection, e.g., via USB, is required.

Further information on UPS components can be found on the Beckhoff [homepage](#).

6.1.3 Accessories for mounting

ZS5301-0003 – Bracket for wall mounting

This bracket is used to mount the device on a level surface or panel without the use of a DIN rail. The bracket can be mounted without loosening the DIN rail brackets.

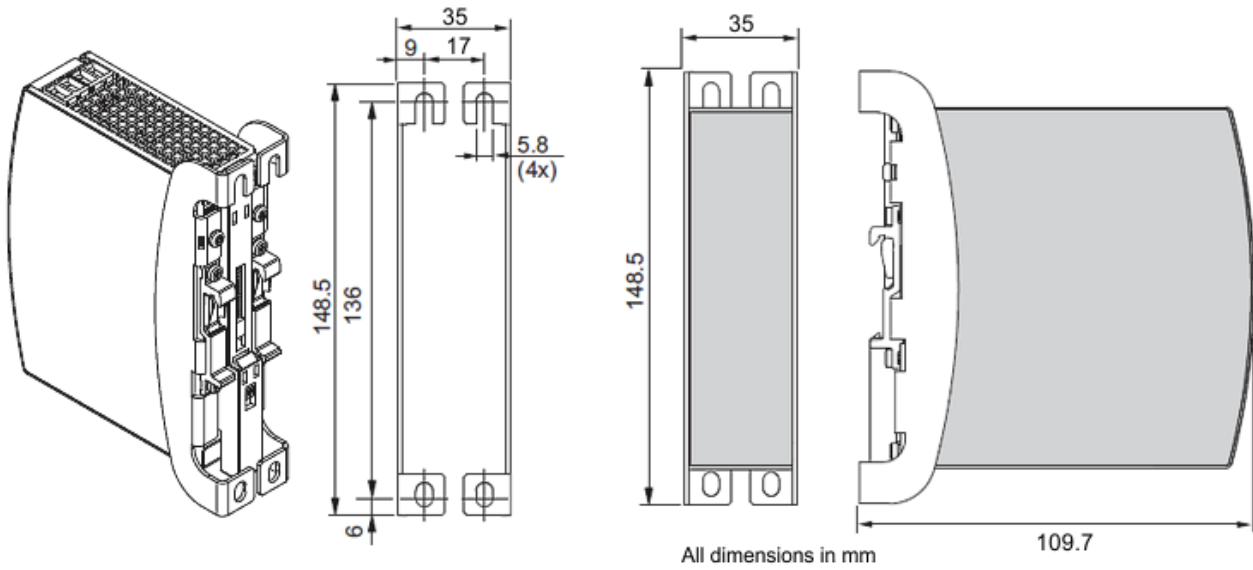

Fig. 31: Isometric view, installation dimensions bracket for wall mounting

6.2 Documentation issue status

Version	Comment
1.1	<ul style="list-style-type: none">- Chapter "Parallel use for redundancy" added- Chapter "Declaration of conformity and approvals" updated- Chapter "Accessories" updated- Chapter "Disposal" added- Update structure
1.0	<ul style="list-style-type: none">- First public issue
0.4	<ul style="list-style-type: none">- Complements, corrections
0.3	<ul style="list-style-type: none">- Complements, corrections
0.2	<ul style="list-style-type: none">- Complements, corrections
0.1	<ul style="list-style-type: none">- Preliminary documentation for PS2001-2405-0000

6.3 Support and Service

Beckhoff and their partners around the world offer comprehensive support and service, making available fast and competent assistance with all questions related to Beckhoff products and system solutions.

Beckhoff's branch offices and representatives

Please contact your Beckhoff branch office or representative for local support and service on Beckhoff products!

The addresses of Beckhoff's branch offices and representatives round the world can be found on her internet pages: www.beckhoff.com

You will also find further documentation for Beckhoff components there.

Support

The Beckhoff Support offers you comprehensive technical assistance, helping you not only with the application of individual Beckhoff products, but also with other, wide-ranging services:

- support
- design, programming and commissioning of complex automation systems
- and extensive training program for Beckhoff system components

Hotline: +49 5246 963 157
e-mail: support@beckhoff.com
web: www.beckhoff.com/support

Service

The Beckhoff Service Center supports you in all matters of after-sales service:

- on-site service
- repair service
- spare parts service
- hotline service

Hotline: +49 5246 963 460
e-mail: service@beckhoff.com
web: www.beckhoff.com/service

Headquarters Germany

Beckhoff Automation GmbH & Co. KG

Hülshorstweg 20
33415 Verl
Germany

Phone: +49 5246 963 0
e-mail: info@beckhoff.com
web: www.beckhoff.com

More Information:

www.beckhoff.com/ps2001-2405-0000

Beckhoff Automation GmbH & Co. KG
Hülshorstweg 20
33415 Verl
Germany
Phone: +49 5246 9630
info@beckhoff.com
www.beckhoff.com

