

Documentation | EN

PS9711-2410-0000

DC/DC Converter 24 V / 24 V, 10 A, 240 W



Table of contents

1 Overview	5
2 Foreword	6
2.1 Notes on the documentation	6
2.2 Safety instructions	7
2.3 Terminology and abbreviations	9
3 Technical data, mounting, wiring	10
3.1 DC input	10
3.2 Input inrush current	12
3.3 Soft-Start feature	13
3.4 Output	14
3.5 Hold-up time	15
3.6 Efficiency and losses	16
3.7 Lifetime expectancy	17
3.8 MTBF	17
3.9 Connection terminals	18
3.10 Functional wiring diagram	19
3.11 Front side and operating elements	20
3.12 EMC	21
3.13 Environment	22
3.14 Safety and protection features	23
3.15 Dielectric strength	24
3.16 Declaration of conformity and approvals	25
3.17 Dimensions and weight	26
4 Application notes	27
4.1 Peak current capability	27
4.2 Output circuit breakers	28
4.3 Charging batteries	29
4.4 Series operation	29
4.5 Parallel use to increase power	30
4.6 Parallel use for redundancy	30
4.7 Use in a tightly sealed enclosure	31
4.8 Mounting orientations	32
5 Disposal	34
6 Appendix	35
6.1 Accessories	35
6.1.1 Redundancy and Buffer Modules	35
6.1.2 Accessories for mounting	36
6.2 Documentation issue status	38
6.3 Support and Service	39

1 Overview

PS9711-2410-0000 | DC/DC converter 24V / 24V, 10A, 240W



- 24V DC-Input
- Isolated 24Vdc Output
- Efficiency 94.2%
- Width only 42mm
- 20% Output Power Reserves
- Full Power Between -25°C and +60°C
- Soft-start Function
- Minimal Inrush Current Surge
- Reverse Input Polarity Protection

The PS9711-2410-0000 is a DIN-rail mountable DC/DC converter with an input voltage of 18 to 35 V DC which provides a floating, stabilized and galvanically separated SELV/PELV output voltage of 24 V DC with 10A.

It contains various functions and can be used for the following purposes:

- Convert voltages to another voltage level
- refresh, amplify and stabilize voltages
- provide a galvanically isolated SELV/PELV voltage

The most outstanding features of PS9711-2410-0000 are the high efficiency, the small size, the extra Power reserves, and the wide operational temperature range.

The device has a power reserve of 20% included, which may even be used continuously at temperatures up to +45°C.

Overview of technical data ^{*)}

Overview of technical data	PS9711-2410-0000
Output voltage	DC 24V (nominal)
Adjustment range	24 - 28V (factory setting 24.1V)
Output current	12.0-10.3A (amb. below +45°C) 10.0-8.6A (amb. at +60°C) 7.5-6.5A (amb. at +70°C) Derate linearly between +45°C and +70°C
Input voltage	DC 24V -25%/+46%
Input current	10.5A
Input inrush current	8A peak, at 40°C, cold start
Efficiency	94.2%
Power losses	14.8W
Hold-up time	4ms
Temperature range	-25°C to +70°C
Size (W x H x D)	42 x 124 x 117mm (without DIN rail)
Weight	500 g
Approvals/markings	CE

^{*)} All values are typical figures specified at 24Vdc input voltage 24V, 10A output load, 25°C ambient and after a 5-minute run-in time unless otherwise noted.

2 Foreword

2.1 Notes on the documentation

Copyright

© Beckhoff Automation GmbH & Co. KG, Germany.

The reproduction, distribution and utilization of this document as well as the communication of its contents to others without express authorization are prohibited.

Offenders will be held liable for the payment of damages. All rights reserved in the event of the grant of a patent, utility model or design.

Disclaimer

The documentation has been prepared with care. The products described are, however, constantly under development.

We reserve the right to revise and change the documentation at any time and without prior announcement.

No claims for the modification of products that have already been supplied may be made on the basis of the data, diagrams and descriptions in this documentation.

Trademarks

Beckhoff®, TwinCAT®, TwinCAT/BSD®, TC/BSD®, EtherCAT®, EtherCAT G®, EtherCAT G10®, EtherCAT P®, Safety over EtherCAT®, TwinSAFE®, XFC®, XTS® and XPlanar® are registered trademarks of and licensed by Beckhoff Automation GmbH. Other designations used in this publication may be trademarks whose use by third parties for their own purposes could violate the rights of the owners.

Patent Pending

The EtherCAT Technology is covered, including but not limited to the following patent applications and patents: EP1590927, EP1789857, EP1456722, EP2137893, DE102015105702 with corresponding applications or registrations in various other countries.

Intended audience

This description is only intended for the use of trained specialists in control and automation engineering who are familiar with the applicable national standards.

It is essential that the documentation and the following notes and explanations are followed when installing and commissioning these components.

The qualified personnel is obliged to always use the currently valid documentation.

The responsible staff must ensure that the application or use of the products described satisfy all the requirements for safety, including all the relevant laws, regulations, guidelines and standards.

2.2 Safety instructions

Description of instructions

In this documentation the following instructions are used.
These instructions must be read carefully and followed without fail!

DANGER

Serious risk of injury!

Failure to follow this safety instruction directly endangers the life and health of persons.

WARNING

Risk of injury!

Failure to follow this safety instruction endangers the life and health of persons.

CAUTION

Personal injuries!

Failure to follow this safety instruction can lead to injuries to persons.

NOTICE

Damage to environment/equipment or data loss

Failure to follow this instruction can lead to environmental damage, equipment damage or data loss.



Tip or pointer

This symbol indicates information that contributes to better understanding.

Intended use

This device is designed for installation in a housing and is intended for general professional use, for example in industrial control systems or office, communication and measuring equipment.

Do not use this power supply in installations where a malfunction could cause serious injury or danger to human life.

Exclusion of liability

All the components are supplied in particular hardware and software configurations appropriate for the application. Modifications to hardware or software configurations other than those described in the documentation are not permitted, and nullify the liability of Beckhoff Automation GmbH & Co. KG.

Personnel qualification

This description is only intended for trained specialists in control, automation and drive engineering who are familiar with the applicable national standards.

Safety regulations

Please note the following safety instructions and explanations!
Product-specific safety instructions can be found on following pages or in the areas mounting, wiring, commissioning etc.



Safety instructions and installation requirements for PS9711-2410-0000 power supply unit**⚠ DANGER****Danger of electric shock, fire, injuries, injuries resulting in death!**

- Turn power off before working on the device. Protect against inadvertent re-powering.
- Do not modify or repair the device.
- Do not open the device, as high voltages are present inside.
- Use caution to prevent any foreign objects from entering the housing.
- Do not use in wet locations or in areas where moisture or condensation can be expected.
- Do not touch during power-on, and immediately after power-off. Hot surface may cause burns.

● Further notes on installation requirements**i**

- This device may only be installed and put into operation by qualified personnel.
- This device does not contain serviceable parts. The tripping of an internal fuse is caused by an internal defect.
- If damage or malfunction should occur during installation or operation, immediately turn power off and send unit to the factory for inspection.
- Install device in an enclosure providing protection against electrical, mechanical and fire hazards.
- Install the device onto a DIN-rail according to EN 60715 with the input terminals on the bottom of the device. Other mounting orientations require a reduction in output current.
- Make sure that the wiring is correct by following all local and national codes. Use appropriate copper cables that are designed for a minimum operating temperature of 60°C for ambient temperatures up to +45°C, 75°C for ambient temperatures up to +60°C and 90°C for ambient temperatures up to +70°C. Ensure that all strands of a stranded wire enter the terminal connection.
- Unused screw terminals should be securely tightened.
- The device is designed for pollution degree 2 areas in controlled environments. No condensation or frost allowed.
- The enclosure of the device provides a degree of protection of IP20.
- The input can be powered from batteries or similar DC sources. The voltage between the input terminals and ground must not exceed 60Vdc continuously.
- The input must be powered from a PELV or SELV source or an "Isolated Secondary Circuit" in order to maintain a SELV or PELV output.
- Check for correct input polarity. The device will not operate when the voltage is reversed.
- A disconnecting means shall be provided for the input of the device.
- The device is designed as "Class of Protection III" equipment according to IEC 61140.
- Do not use without a proper PE (Protective Earth) connection.
- The device is designed for convection cooling and does not require an external fan. Do not obstruct airflow and do not cover ventilation grid!
- The device is designed for altitudes up to 5000m. See additional requirements in this document for use above 2000m.
- Keep the following minimum installation clearances: 40mm on top, 20mm on the bottom, 5mm left and right side. Increase the 5mm to 15mm in case the adjacent device is a heat source. When the device is permanently loaded with less than 50%, the 5mm can be reduced to zero.
- The device is designed, tested and approved for branch circuits up to 50A without additional protection device. If an external fuse is utilized, do not use circuit breakers smaller than 20A B- or C-Characteristic to avoid a nuisance tripping of the circuit breaker.
- The maximum surrounding air temperature is +70°C. The operational temperature is the same as the ambient or surrounding air temperature and is defined 2cm below the device.
- The device is designed to operate in areas between 5% and 95% relative humidity.

2.3 Terminology and abbreviations

PE and the earthing symbol 	PE is the abbreviation for "protective earth" and has the same meaning as the earthing symbol 
Earth, ground	This document uses the term "earth" which is the same as the U.S. term "ground".
T.b.d.	Still to be defined, value or description will follow in due course.
DC 24 V	A figure displayed with the AC or DC before the value represents a nominal voltage with standard tolerances included. Example: DC 12 V refers to a 12 V battery, regardless of whether it is fully charged (13.7 Vdc) or discharged (10 Vdc).
24 Vdc	A value followed by the unit Vac or Vdc is an instantaneous value that does not contain any additional tolerances.
may	A keyword indicating a choice without implied preference.
shall	A keyword indicating a mandatory requirement.
should	A keyword indicating a choice with a clearly preferred method of implementation.

3 Technical data, mounting, wiring

3.1 DC input

The input can be powered from batteries or similar DC sources and must be a PELV or SELV source or an "Isolated Secondary Circuit" in order to maintain a SELV or PELV output.

DC input			
DC input	Nom.	DC 24V	-25%/+46%
DC input range		18.0-35.0Vdc	
Allowed voltage between input and earth/ground	Max.	60Vdc or 42.2Vac	according to IEC 62477-1
Allowed input ripple voltage	Max.	5Vpp	In the frequency range from 47 to 500Hz, the momentary input voltage must always be within the specified limits.
Turn-on voltage	Typ.	17.5Vdc	Steady-state value, see Fig. "Input voltage range"
Shut-down voltage	Typ.	15.5Vdc	Steady-state value, see Fig. "Input voltage range"
Input current	Typ.	10.5A	At 24Vdc input and 24V, 10A output load, see Fig. "Input current vs. output load"
		14.3A	At 18Vdc input and 24V, 10A output load, see Fig. "Input current vs. output load"
Start-up delay	Typ.	150ms	See Fig. "Input voltage range"
Rise time	Typ.	110ms	At 24V, 10A constant current load, 0mF load capacitance, see Fig. "Turn-on behavior, definitions"
		250ms	At 24V, 10A constant current load, 10mF load capacitance, see Fig. "Turn-on behavior, definitions"
Turn-on overshoot	Max.	250mV	See Fig. "Turn-on behavior, definitions"
Input capacitance	Typ.	4 300µF	Installed inside the device, external capacitors on the input are allowed without any limitations.
External input protection		Non-user replaceable slow blow, high breaking capacity fuse. See chapter "Further notes on installation requirements [▶ 8]"	

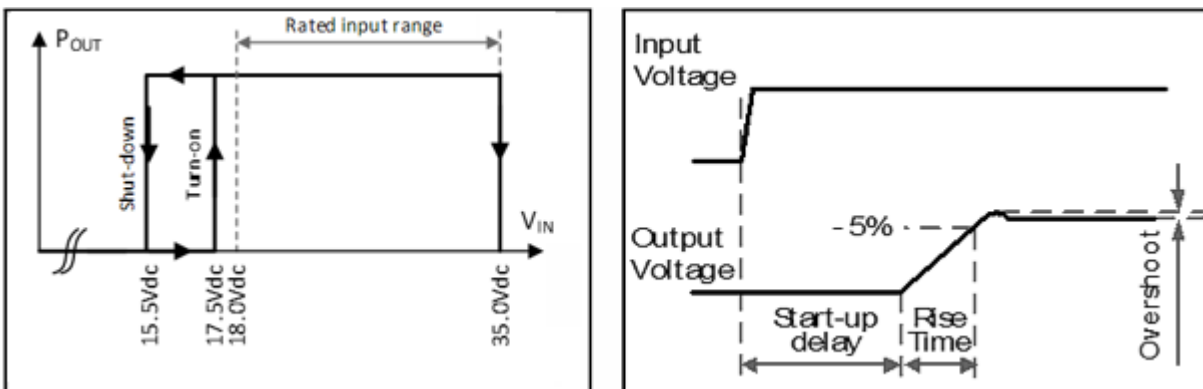

Fig. 1: Input voltage range, Turn-on behavior, definitions

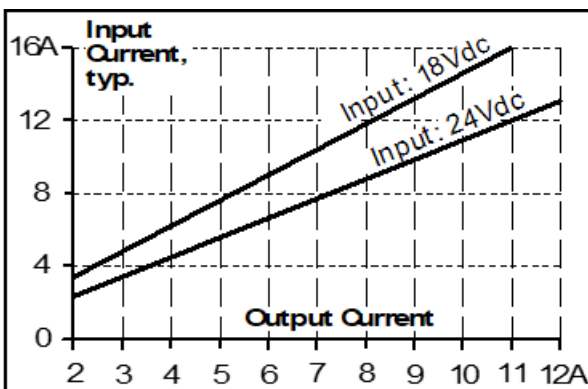

Fig. 2: Input current vs. output load

Requirements for the Supplying Source

In certain circumstances, the input filter of the DC/DC converter can show a resonant effect which is caused by the supplying network. Especially when additional external input filters are utilized, a superimposed AC voltage can be generated on the input terminals of the DC/DC converter which might cause a malfunction of the unit. Therefore, additional input filters are not recommended. To avoid the resonant effects, the minimal resistance of the supplying network which depends on the inductance of the input network, shall be above the boundary curve in Fig. "External input filter requirements to avoid filter instabilities".

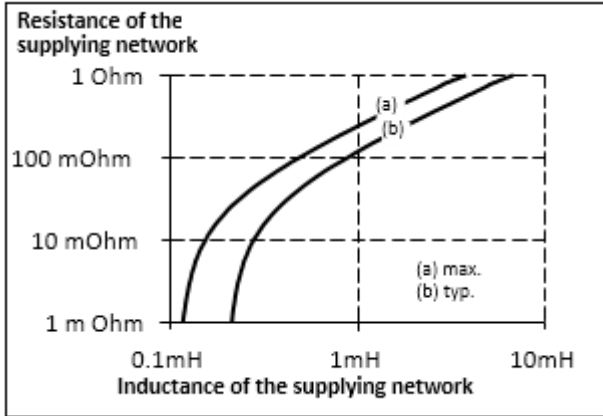

Fig. 3: External input filter requirements to avoid filter instabilities

3.2 Input inrush current

Active inrush current limitation (NTCs that are bridged by a MOSFET) limits the inrush current after the input voltage is switched on.

The charging current into EMI suppression capacitors is disregarded in the first microseconds after switch-on.

Input inrush current	Max.	8A	At +25°C ambient, cold start
	Max.	10A	At +40°C ambient, cold start
	Typ.	6A _{peak}	At +25°C ambient, cold start
	Typ.	8A _{peak}	At +40°C ambient, cold start
Inrush energy	Max.	1A ² s	At +40°C ambient, cold start

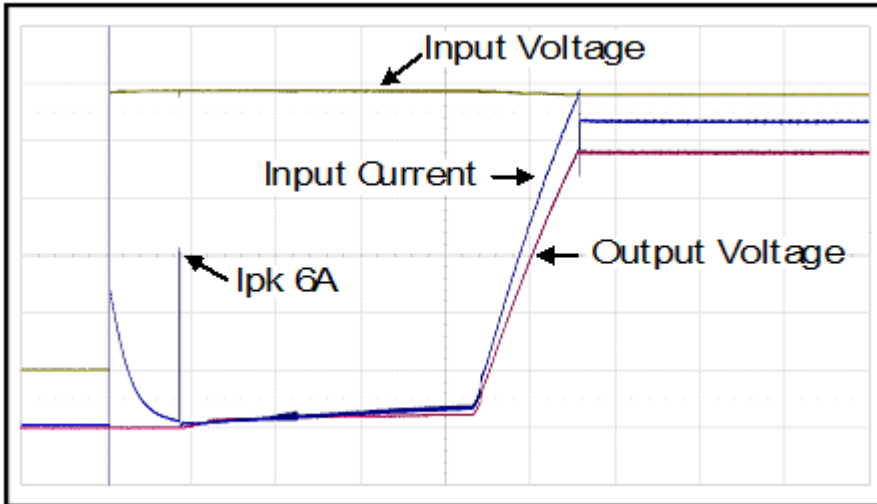

Fig. 4: Typical input inrush current behavior at nominal load and 25°C ambient

- Input: 24Vdc
- Output: 24V, 10A, constant current load
- Ambient: 25°C
- Input current: 2A / DIV
- Input voltage: 5V / DIV
- Output voltage: 5V / DIV
- Time basis: 100ms / DIV

3.3 Soft-Start feature

After the DC/DC converter is turned on, the internal output current rises slowly to its nominal value. This method charges the output capacitors (internal and external capacitors) slowly and avoids high input currents during turn-on.

High input currents can produce a high voltage drop on the input wiring (especially with long and thin cables) which reduces the terminal voltage on the DC/DC converter. If the terminal voltage is below the shut-down voltage, the DC/DC converter will turn-off and will make a new start-up attempt. This effect is avoided with the integrated soft-start function. Please note, that this function increases the rise time of the output voltage by a small amount.

3.4 Output

The output provides a SELV/PELV rated voltage, which is galvanically isolated from the input voltage and is designed to supply any kind of loads, including unlimited capacitive and inductive loads.

The output is electronically protected against overload, no-load and short-circuits. In case of a protection event, audible noise may occur.

Output voltage	Nom.	24V	
Adjustment range	Min.	24-28V	
	Max.	30V	This is the maximum output voltage which can occur at the clockwise end position of the potentiometer due to tolerances. It is not a guaranteed value which can be achieved.
Factory setting		24.1V	±0.2%, at full load, cold unit
Line regulation	Max.	25mV	Between 18 and 35Vdc input voltage variation
Load regulation	Max.	100mV	Between 0 and 10A load variation, static value
Ripple and noise voltage	Max.	50mVpp	Bandwidth 20Hz to 20MHz, 50Ohm
Output current	Nom.	12A	At 24V and an ambient temperature below 45°C
	Nom.	10A	At 24V and 60°C ambient temperature
	Nom.	7.5A	At 24V and 70°C ambient temperature
	Nom.	10.3A ¹⁾	At 28V and an ambient temperature below 45°C
	Nom.	8.6A	At 28V and 60°C ambient temperature
	Nom.	6.4A	At 28V and 70°C ambient temperature
Overload behavior		Continuous current	
Overload/ short-circuit current	Min.	15A	Continuous current Typ. Load impedance 100mOhm
Output capacity	Typ.	4 500µF	Included in the power supply
Back-feeding loads	Max.	35V	The unit is resistant and does not show malfunctioning when a load feeds back voltage to the power supply. It does not matter whether the power supply is on or off. The absorbing energy can be calculated according to the built-in large sized output capacitor.

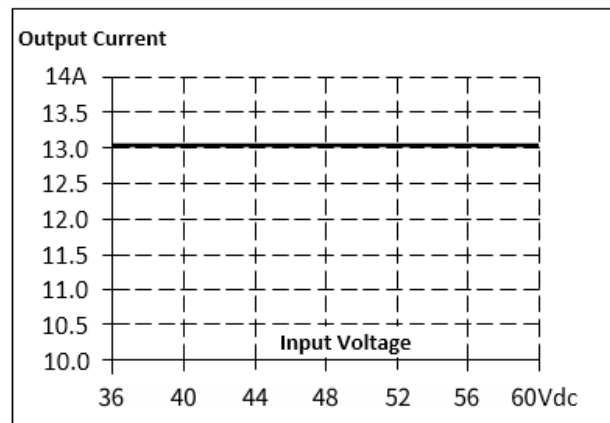
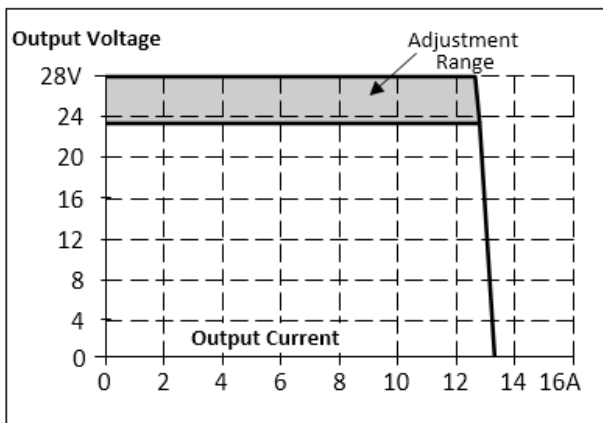

Fig. 5: Output voltage vs. output current at 24Vdc input voltage, typ., Current limitation vs. input voltage, (23V constant voltage load), typ.

3.5 Hold-up time

The input side of the DC/DC converter is equipped with a bulk capacitor which keeps the output voltage alive for a certain period of time when the input voltage dips or is removed. The bulk capacitor can be discharged by loading the DC/DC converter on the output side or through a load which is parallel to the input. There is no protection in the DC/DC converter which prevents current from flowing back to the input terminals. If prevention is needed, an external diode should be used.

At no load, the hold-up time can be up to several seconds. The green DC-OK LED is also on during this time.

Hold-up time	Typ.	8ms	At 24Vdc input voltage, 24V, 5A output, see Fig. Hold-up time vs. input voltage
	Min.	6.5ms	At 24Vdc input voltage, 24V, 5A output, see Fig. Hold-up time vs. input voltage
	Typ.	4ms	At 24Vdc input voltage, 24V, 10A output, see Fig. Hold-up time vs. input voltage
	Min.	3.2ms	At 24Vdc input voltage, 24V, 10A output, see Fig. Hold-up time vs. input voltage

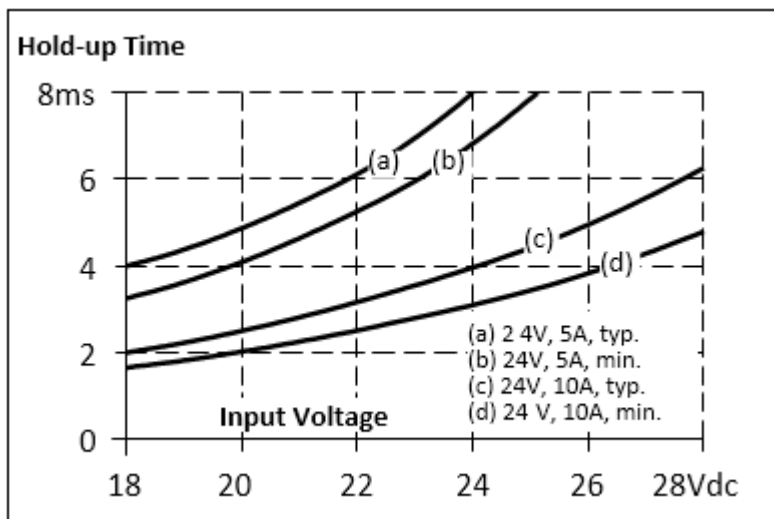

Fig. 6: Hold-up time vs. input voltage

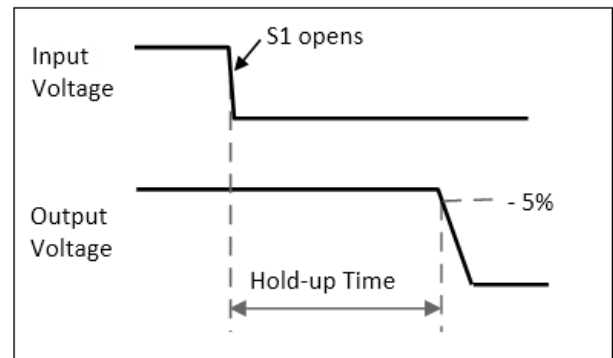
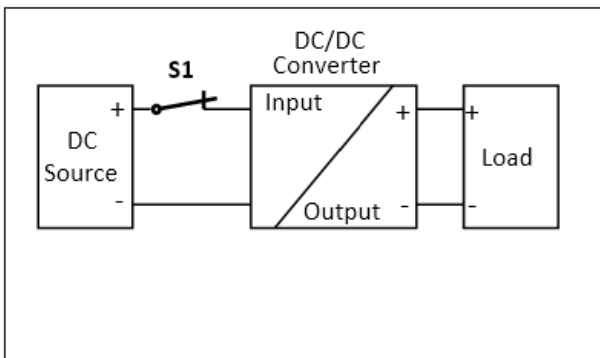

Fig. 7: Shut-down test setup; Shut-down behavior, definitions

3.6 Efficiency and losses

		Input 24Vdc	
Efficiency	Typ.	94.2%	At 24V, 10A
	Typ.	93.7%	At 24V, 12A (Extra Power)
Average efficiency ¹⁾	Typ.	94.3%	At 25% at 2.5A, 25% at 5A, 25% at 7.5A. 25% at 10A
Losses	Typ.	1.75W	At no output load
	Typ.	6.8W	At 24V, 5A
	Typ.	14.8W	At 24V, 10A
	Typ.	19.5W	At 24V, 12A

¹⁾ The average efficiency is an assumption for a typical application where the power supply is loaded with 25% of the nominal load for 25% of the time, 50% of the nominal load for another 25% of the time, 75% of the nominal load for another 25% of the time and with 100% of the nominal load for the rest of the time.

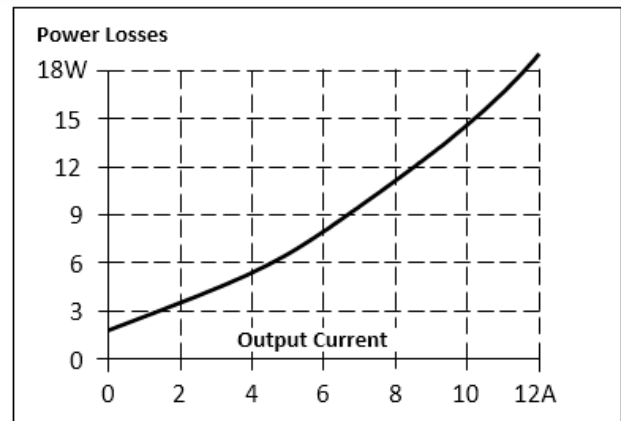
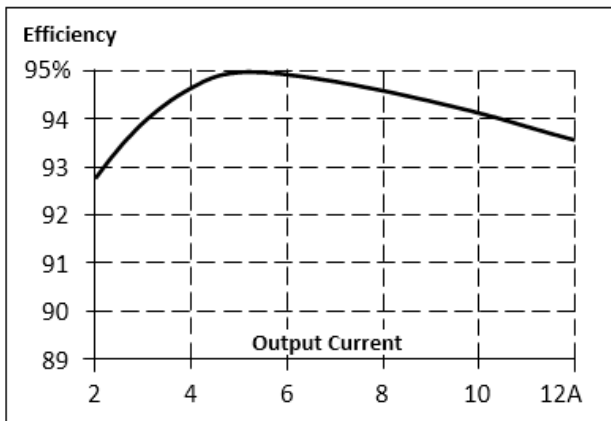

Fig. 8: Efficiency vs. output current at 24V output and 24Vdc input voltage, typ; Losses vs. output current at 24V output and 24Vdc input voltage, typ.

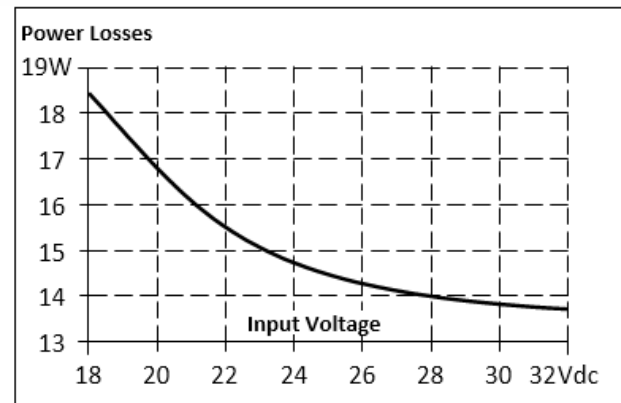
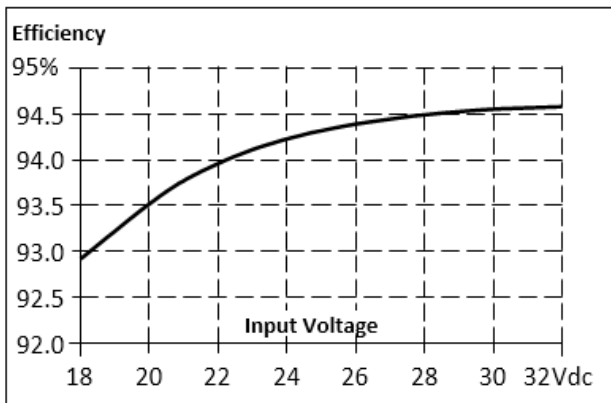

Fig. 9: Efficiency vs. input voltage at 24V, 10A, typ; Losses vs. input voltage at 24V, 10A, typ.

3.7 Lifetime expectancy

The lifetime expectancy shown in the table indicates the minimum number of operating hours (service life) and is determined by the lifetime expectancy of the built-in electrolytic capacitors. The lifetime expectancy is stated in operating hours and is calculated according to the specifications of the capacitor manufacturer. The manufacturer of the electrolytic capacitors only guarantees a maximum life of up to 15 years (131,400h).

Any number exceeding this value represents a calculated theoretical lifetime which can be used to compare devices.

	Input 24Vdc	
Lifetime expectancy	299 000h	At 24V, 5A and 40°C
	103 000h	At 24V, 10A and 40°C
	56 000h	At 24V, 12A and 40°C
	844 000h	At 24V, 5A and 25°C
	292 000h	At 24V, 10A and 25°C
	159 000h	At 24V, 12A and 25°C

3.8 MTBF

MTBF stands for **Mean Time Between Failure**, which is calculated according to statistical device failures, and indicates reliability of a device. It is the statistical representation of the likelihood of a unit to fail and does not necessarily represent the life of a product.

The MTBF figure is a statistical representation of the likelihood of a device to fail. A MTBF figure of e.g. 1 000 000h means that statistically one unit will fail every 100 hours if 10 000 units are installed in the field. However, it can not be determined if the failed unit has been running for 50 000h or only for 100h.

For these types of units the MTTF (**Mean Time To Failure**) value is the same value as the MTBF value.

	Input 24Vdc	
MTBF SN 29500, IEC 61709	731 000h	At 24V, 10A and 40°C
	1 321 000h	At 24V, 10A and 25°C
MTBF MIL HDBK 217F	267000h	At 10A and 40°C; Ground Benign GB40
	392000h	At 10A and 25°C; Ground Benign GB25
	64000h	At 10A and 40°C; Ground Fixed GF40
	86000h	At 10A and 25°C; Ground Fixed GF25

3.9 Connection terminals

The terminals are designed to be finger-safe according to IP20 and are suitable for field and factory wiring.

Technical data	Input	Output
Connection cross-section	e*: max. 6mm ² f*: max. 4mm ² a*: max. 4mm ² (d<2.8mm)	e*: max. 6mm ² f*: max. 4mm ² a*: max 4mm ² (d<2.8mm)
Connection cross section (AWG)	e*: AWG 20-10 f*: AWG 20-10 a* AWG 20-10 (d<2.8mm)	e*: AWG 20-10 f*: AWG 20-10 a* AWG 20-10 (d<2.8mm)
Strip length	7mm	7mm

e* = solid single wire

f* = stranded wire

a* = with ferrule

Wiring instructions:

- Use suitable copper cables that are designed for at least the following operating temperatures: +60°C for ambient temperatures up to +45°C, +75°C for ambient temperatures up to +60°C, and +90°C for ambient temperatures up to +70°C.
- Observe the national installation rules and regulations!
- Make sure that all single wires of a strand are connected to the terminal!
- Unused terminals should be tightened firmly.
- Ferrules are permitted.

Daisy chaining of outputs

Daisy chaining (jumping from one DC/DC converter output to the next) is allowed as long as the average output current through one terminal pin does not exceed 25A. If the current is higher, use a separate distribution terminal block.

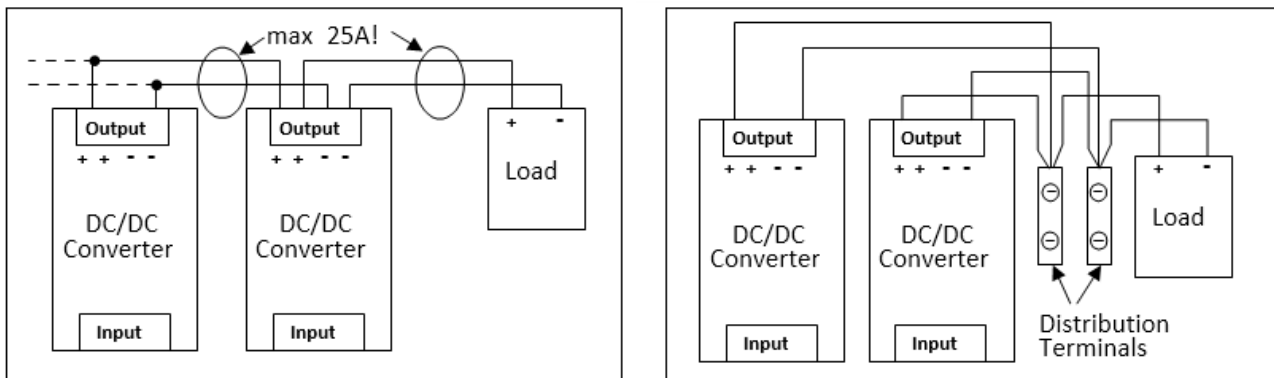

Fig. 10: Daisy chaining of outputs; Using distribution terminals

3.10 Functional wiring diagram

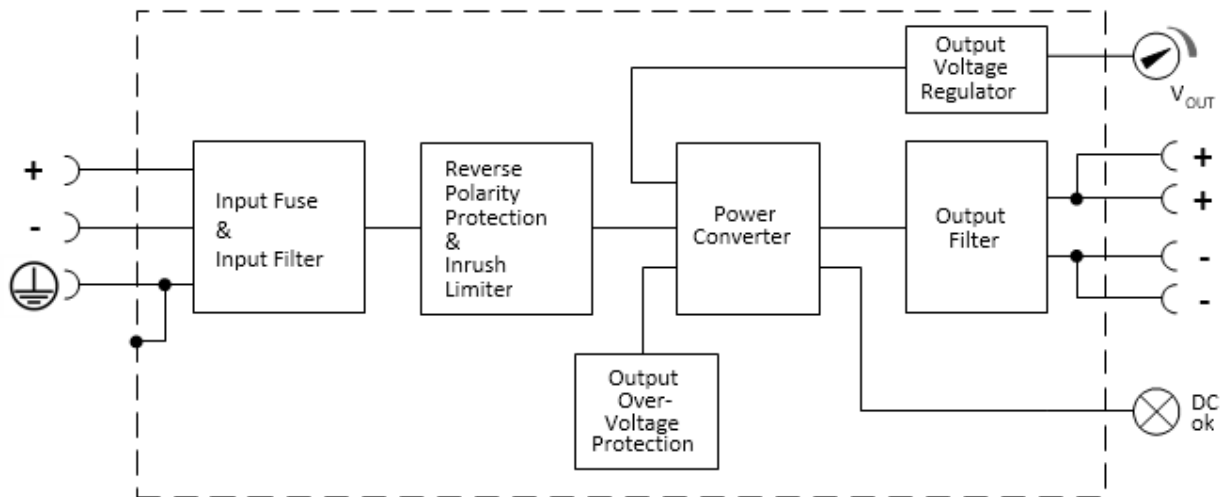



Fig. 11: Functional wiring diagram

3.11 Front side and operating elements



Fig. 12: Front PS9711-2410-0000

Input terminals (screw terminals)

Designation (A)	Description
+	positive input
-	negative input
	PE -> Protective Earth (Ground) connection

Output terminals (screw terminals)

Designation (B)	Description
+	positive output, two identical "+" poles
-	negative output, two identical "-" poles

Potentiometer for the output voltage

Designation (C)	Description
Potentiometer cover	Open the flap to adjust the output voltage. Factory setting: 24.1 V

DC-OK LED

Designation (D)	Description
LED green	DC-OK LED (green) On: voltage on the output terminals is > 21V

3.12 EMC

The EMC behavior of the device is designed for applications in industrial environment as well as in residential, commercial and light industry environments.

The device is investigated according to the generic standards EN 61000-6-1, EN 61000-6-2, EN 61000-6-3 and EN 61000-6-4.

EMC immunity				
Electrostatic discharge	EN 61000-4-2	Contact discharge	8kV	Criterion A
		Air discharge	15kV	Criterion A
Electromagnetic RF field	EN 61000-4-3	80MHz-2.7GHz	20V/m	Criterion A
	EN 61000-4-3	2.7GHz-6GHz	10V/m	Criterion A
Fast transients (Burst)	EN 61000-4-4	Input lines	4kV	Criterion A
		Output lines	2kV	Criterion A
Surge voltage on input	EN 61000-4-5	+ → -	1kV	Criterion A
		+/- → chassis ground	2kV	Criterion A
Surge voltage on output	EN 61000-4-5	+ → -	500V	Criterion A
		+ / - → chassis ground	1kV	Criterion A
Conducted disturbance	EN 61000-4-6	0.15-80MHz	20V	Criterion A

Criteria:

A: The device shows normal operation behavior within the defined limits.

EMC emission		
Conducted emission on input lines	IEC/CISPR 16-1-2, IEC/CISPR 16-2-1	Limits for DC power networks according to EN 61000-6-3 fulfilled
Conducted emission on output lines	IEC/CISPR 16-1-2, IEC/CISPR 16-2-1	Limits for DC power networks according to EN IEC 61000-6-8 fulfilled
Radiated emission	EN 55011, EN 55022	Class B
This device complies with FCC Part 15 rules.		
Operation is subjected to following two conditions: (1) this device may not cause harmful interference, and (2) this device must accept any interference received, including interference that may cause undesired operation.		

Switching frequencies		
Main converter	50kHz to 300kHz	Output load and input voltage dependent

3.13 Environment

Environment		
Operating temperature	-25°C to +70°C	The operational temperature is the ambient or surrounding temperature and is defined as the air temperature 2cm below the device.
Storage temperature	-40°C to +85°C	For storage and transport
Output derating	3.2W/°C 6W/°C 15W/1000m or 5K/1000m 9W/-5kPa or 3K/-5kPa	Between +45°C and +60°C Between +60°C and +70°C For altitudes >2000m see Fig. below For atmospheric pressures <80kPa, see Fig. below
	The derating is not hardware controlled. The customer must take care by himself to stay below the de-rated current limits in order not to overload the unit.	
Humidity	5 to 95% r.h.	According to IEC 60068-2-30
Atmospheric pressure	110-47kPa	See Fig. below for details
Altitude	Up to 5000m	See Fig. below for details
Degree of pollution	2	According to IEC 62477-1, not conductive
Vibration sinusoidal	2-17.8Hz: ±1.6mm; 17.8-500Hz: 2g 2 hours / axis	According to IEC 60068-2-6
Shock	30g 6ms, 20g 11ms 3 bumps / direction, 18 bumps in total	According to IEC 60068-2-27
	Shock and vibration is tested in combination with DIN-Rails according to EN 60715 with a height of 15mm and a thickness of 1.3mm and standard orientation.	
Audible noise	Some audible noise may be emitted from the power supply during no load, overload or short circuit.	

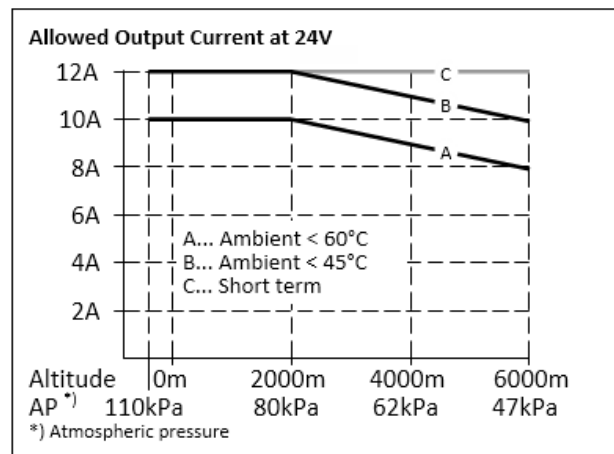
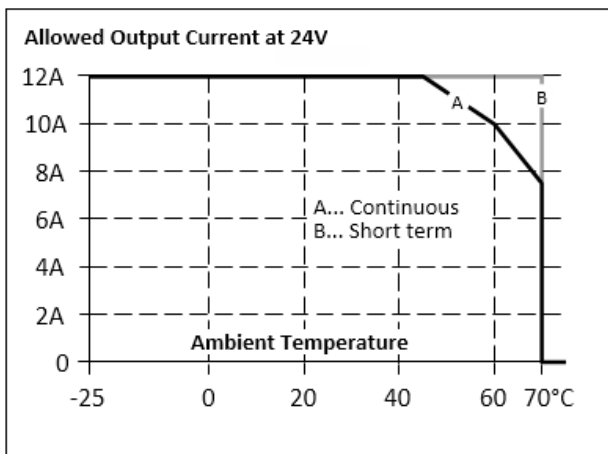

Fig. 13: Output current vs. ambient temp.; Output current vs. altitude at 24V

3.14 Safety and protection features

Insulation resistance	Min. 500MΩ	In the delivery state between input and output, measured with 500Vdc
	Min. 500MΩ	In the delivery state between input and Chassis Ground, measured with 500Vdc
	Min. 500MΩ	In the delivery state between output and Chassis Ground, measured with 500Vdc
PE resistance	Max. 0.1Ω	Resistance between PE terminal and the housing in the area of the DIN-rail mounting bracket.
Output overvoltage protection	Typ. 31Vdc Max. 32.5Vdc	In case of an internal defect, a redundant circuit limits the maximum output voltage. The output shuts down and automatically attempts to restart.
Class of protection	III	According to IEC 61140
Degree of protection	IP 20	According to EN/IEC 60529
Over-temperature protection	Not included	
Input transient protection	MOV (Metal Oxide Varistor)	For protection values see chapter "EMC [► 21]".
Internal input fuse	Included	Not user replaceable slow-blow high-braking capacity fuse
Touch current (leakage current)	The leakage current, which is produced by the DC/DC converter itself, depends on the input voltage ripple and need to be investigated in the final application. For a smooth DC input voltage, the produced leakage current is less than 100µA.	

3.15 Dielectric strength

The output voltage is floating and has no ohmic connection to the ground.

The output is insulated to the input by a double or reinforced insulation.

Type and routine tests are conducted by the manufacturer. Field tests may be conducted in the field using the appropriate test equipment which applies the voltage with a slow ramp (2s up and 2s down). Connect all input-terminals together as well as all output poles before conducting the test. When testing, set the cut-off current settings to the value in the table below.

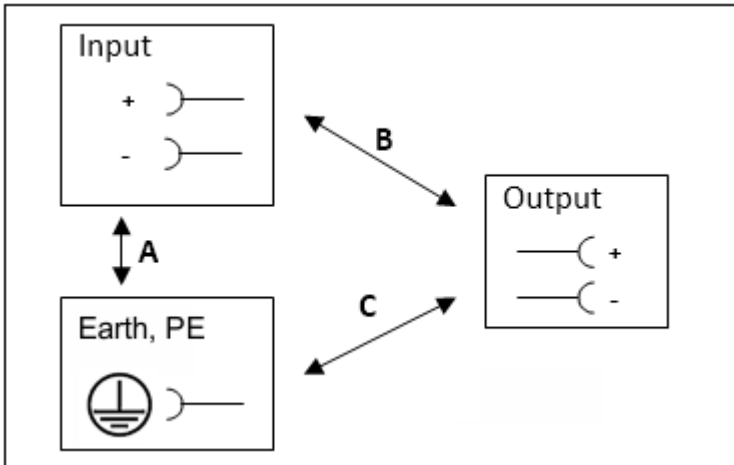



Fig. 14: Dielectric strength

		A	B	C
Type test	60s	1500Vac	1500Vac	500Vac
Routine test	5s	1500Vac	1500Vac	500Vac
Field test	5s	1000Vac	1000Vac	500Vac
Cut-off current setting		40mA	20mA	12mA

It is recommended that either the “+” pole, the “-“ pole or any other part of the output circuit shall be connected to the earth/ground system. This helps to avoid situations in which a load starts unexpectedly or cannot be switched off when unnoticed earth faults occur.

3.16 Declaration of conformity and approvals

	EU declaration of conformity
---	------------------------------

3.17 Dimensions and weight

Dimensions and weight	
Overall width	42mm
Height	124mm
Depth	117mm The height of the DIN rails must be added to the depth of the device to calculate the total installation depth required
DIN rail	Use 35 mm DIN rails according to EN 60715 or EN 50022 with a height of 7.5 or 15mm.
Weight	500 g
Housing material	Body: Aluminum alloy Cover: zinc-plated steel
Installation clearances	See chapter on Safety instructions and installation requirements
Penetration protection	Small parts like screws, nuts, etc. with a diameter larger than 3.5mm

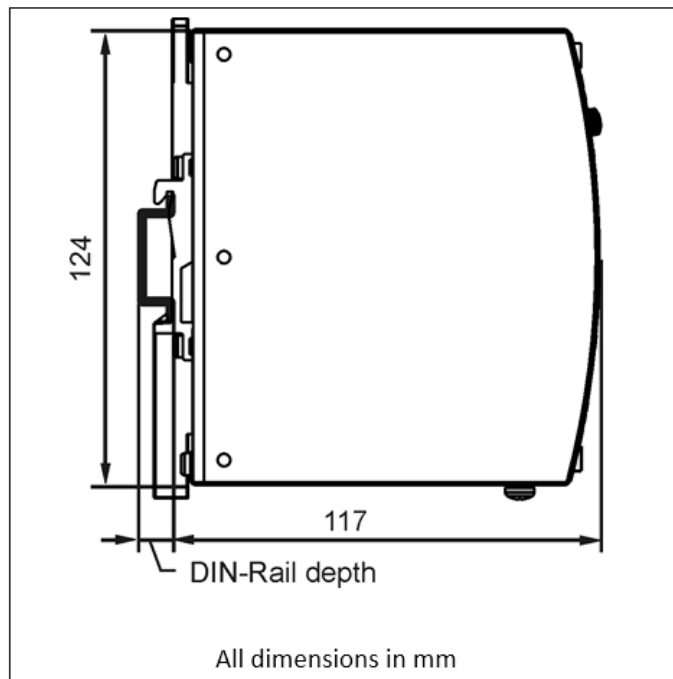
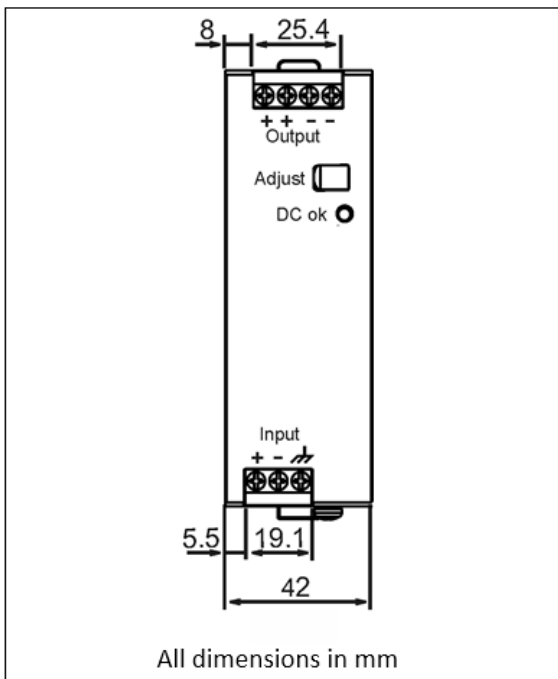

Fig. 15: Front/side view PS9711-2410-0000, all specifications in mm

4 Application notes

4.1 Peak current capability

The unit can deliver peak currents (up to several milliseconds) which are higher than the specified short-term currents.

This helps to start current demanding loads. Solenoids, contactors and pneumatic modules often have a steady state coil and a pick-up coil. The inrush current demand of the pick-up coil is several times higher than the steady-state current and usually exceeds the nominal output current. The same situation applies when starting a capacitive load.

The peak current capability also ensures the safe operation of subsequent circuit breakers of load circuits. The load branches are often individually protected with circuit breakers or fuses. In case of a short or an overload in one branch circuit, the fuse or circuit breaker need a certain amount of over-current to open in a timely manner. This avoids voltage loss in adjacent circuits.

The extra current (peak current) is supplied by the power converter and the built-in large sized output capacitors of the power supply. The capacitors get discharged during such an event, which causes a voltage dip on the output. The following two examples show typical voltage dips:

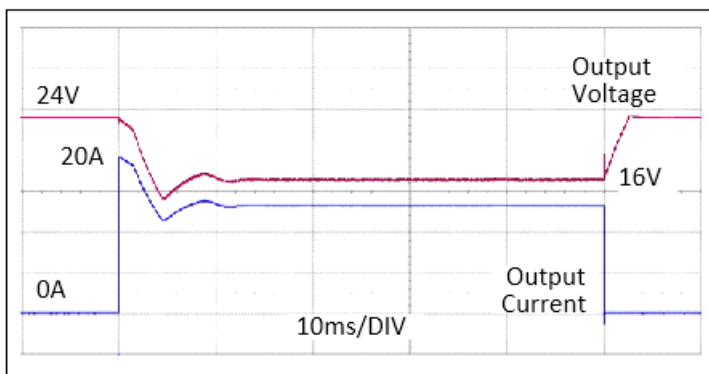

Fig. 16: Peak load 20A (resistive load) for 50ms; Output voltage dips from 24V to 16V

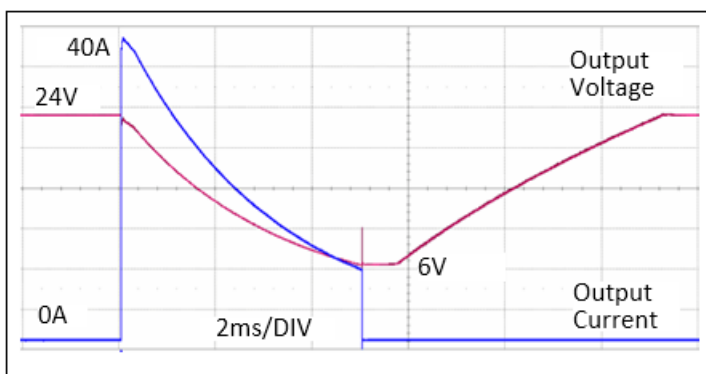

Fig. 17: Peak load 40A (resistive load) for 5ms; Output voltage dips from 24V to 6V

Peak current voltage dips	
Typ. from 24V to 16V	at 20A for 50ms, resistive load
Typ. from 24V to 12V	at 40A for 2ms, resistive load
Typ. from 24V to 6V	at 40A for 5ms, resistive load

4.2 Output circuit breakers

Standard miniature circuit breakers (MCB's or UL 1077 circuit breakers) are commonly used on AC power systems and may also be used on 24V branches.

MCBs are designed to protect wires and circuits. If the amperage and characteristics of the MCB are matched to the wire size being used, the wiring is considered thermally safe whether or not the MCB opens.

To avoid voltage dips and undervoltage situations in adjacent 24V branches supplied by the same source, fast (magnetic) tripping of the MCB is desired. A fast shutdown within 10ms is required, which is approximately the cycle time of PLCs. This requires power supplies with high current reserves and large output capacitors. In addition, the impedance of the faulty branch must be low enough for the current to actually flow. The best current reserve in the power supply will not help if Ohm's law does not allow current to flow. The following table provides typical test results showing which MCBs with B and C characteristics magnetically trip depending on wire size and length.

The following test results indicate the maximum wire length for magnetic (fast) tripping. The wire length is always two times the distance to the load (+ and - wires).

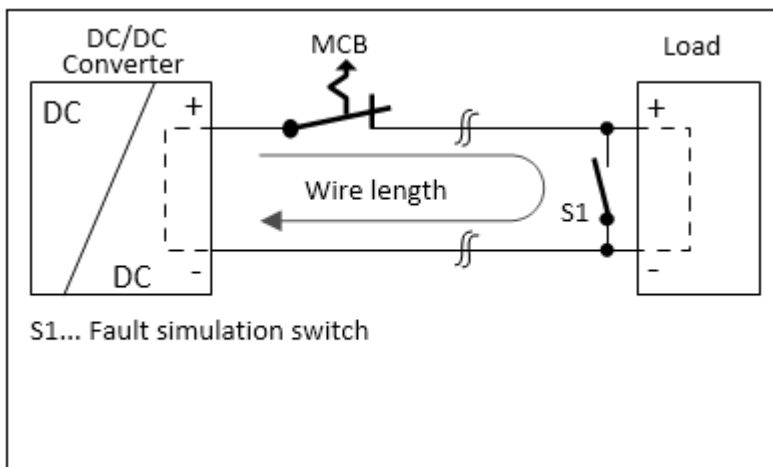

Fig. 18: Test circuit for maximum wire length

Test results for maximum wire length:

	0.75mm ²	1.0mm ²	1.5mm ²	2.5mm ²
C-2A	23m	25m	41m	71m
C-3A	13m	15m	23m	33m
C-4A	4m	6m	8m	13m
C-6A	1m	2m	2m	5m

	0.75mm ²	1.0mm ²	1.5mm ²	2.5mm ²
B-6A	8m	10m	14m	23m
B-10A	1m	2m	2m	3m
B-13A		1m	2m	3m

4.3 Charging batteries

The device can be used to charge lead-acid or maintenance free batteries. Two 12V SLA or VLRA batteries are needed in series connection.

Instructions for charging batteries:

- Ensure that the ambient temperature of the device is below 45°C.
- Set the output voltage (measured at no load and at the end of the battery cable) very precisely to the end-of-charge voltage.

End-of-charge voltage	27.8V	27.5V	27.15V	26.8V
Battery temperature	10°C	20°C	30°C	40°C

- Use a 16A circuit breaker or blocking diode between the device and the battery.
- Ensure that the output current of the device is below the allowed charging current of the battery.
- Use only matched batteries when putting 12V types in series.
- The return current to the device (battery discharge current) is typ. 10mA when the device is switched off except in case a blocking diode is utilized.
- Do not use the devices for battery charging in mounting orientations other than the standard mounting orientation or in any other condition where a reduction of the output current is required (e.g., altitude).

4.4 Series operation

Devices of the same type PS9711-2410-0000 can be connected in series for higher output voltages. It is possible to connect as many units in series as needed, providing the sum of the output voltage does not exceed 150Vdc. Voltages with a potential above 60Vdc must be installed with a protection against touching.

Avoid return voltage (e.g. from a decelerating motor or battery) which is applied to the output terminals.

Keep an installation clearance of 15mm (left / right) between two power supplies and avoid installing the power supplies on top of each other. Do not use power supplies in series in mounting orientations other than the standard mounting orientation.

Pay attention that EMI and inrush current will increase when using multiple devices.

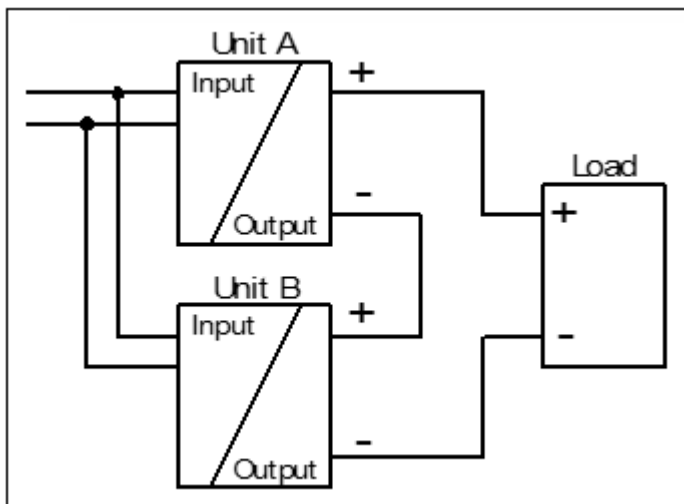

Fig. 19: Series operation

4.5 Parallel use to increase power

Devices of the same type PS9711-2410-0000 can be paralleled to increase the output power. The output voltage shall be adjusted to the same value ($\pm 100\text{mV}$) with the same load conditions on all devices, or the devices can be left with the factory settings.

The ambient temperature is not allowed to exceed $+45^\circ\text{C}$.

If more than three devices are connected in parallel, a fuse or circuit breaker with a rating of 15A or 16A is required on each output. Alternatively, a diode or redundancy module can also be utilized.

Keep an installation clearance of 15mm (left / right) between two devices and avoid installing devices on top of each other. Do not use devices in parallel in mounting orientations other than the standard mounting orientation or in any other condition where a reduction of the output current is required (e.g., altitude).

Pay attention that EMI and inrush current will increase when using multiple devices.

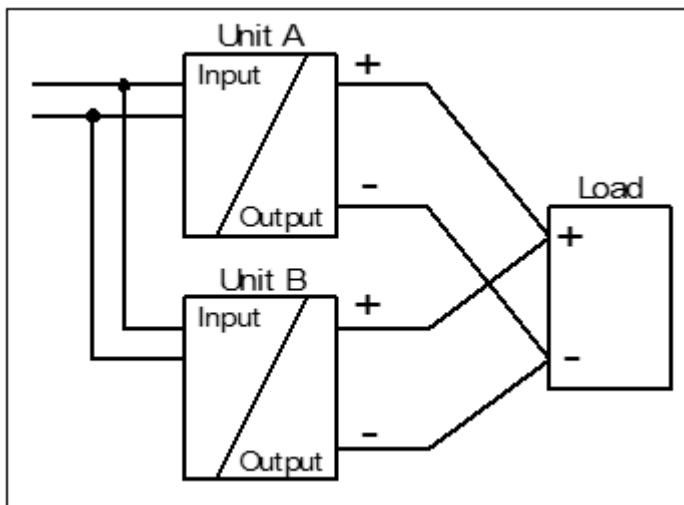

Fig. 20: Parallel connection

4.6 Parallel use for redundancy

1+1 Redundancy

Devices of the same type PS9711-2410-0000 can be paralleled for redundancy to gain higher system availability. Redundant systems require a certain amount of extra power to support the load in case one device fails. The simplest way is to put two devices in parallel. This is called a 1+1 redundancy. In case one device fails, the other one is automatically able to support the load current without any interruption. It is essential to use a redundancy module to decouple devices from each other. This prevents that the defective unit becomes a load for the other device and the output voltage cannot be maintained any more.

1+1 redundancy allows ambient temperatures up to $+70^\circ\text{C}$.

Pay attention that EMI and inrush current will increase when using multiple devices.

Recommendations for building redundant power systems:

- Use separate input fuses for each device.
- Use separate supply systems for each device whenever it is possible.
- It is desirable to set the output voltages of all devices to the same value ($\pm 100\text{mV}$) or leave it at the factory setting.

N+1 Redundancy

Redundant systems for a higher power demand are usually built in a N+1 method. E.g. four devices, each rated for 10A are paralleled to build a 30A redundant system.

Pay attention that EMI and inrush current will increase when using multiple devices.

Keep an installation clearance of 15mm (left / right) between two devices and avoid installing the devices on top of each other.

Do not use devices in parallel in mounting orientations other than the standard mounting orientation or in any other condition, where a reduction of the output current is required.

For N+1 redundancy the ambient temperature is not allowed to exceed +45°C.

Wiring example:

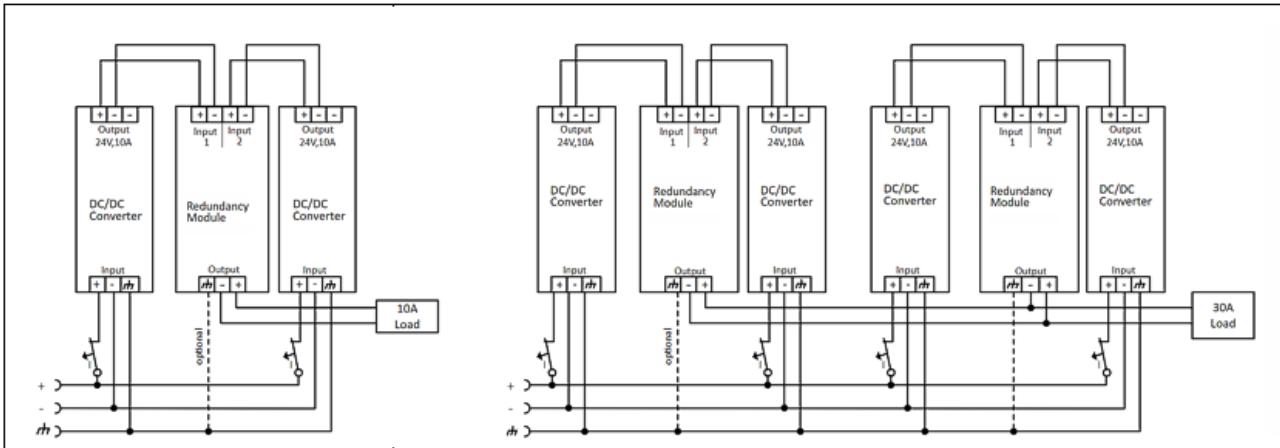

Fig. 21: 1+1 Redundant configuration for 10A load current; N+1 Redundant configuration for 30A load current with multiple DC/DC converters and redundancy module

4.7 Use in a tightly sealed enclosure

When the device is installed in a tightly sealed enclosure, the temperature inside the enclosure will be higher than outside. In such situations, the inside temperature defines the ambient temperature for the device.

In the following test setup, the device is placed in the middle of the enclosure; no other heat producing items are inside the enclosure. The load is placed outside the enclosure.

The temperature sensor inside the enclosure is placed in the middle of the right side of the device with a distance of 1cm.

The following measurement results can be used as a reference to estimate the temperature rise inside the enclosure.

	Case A	Case B
Enclosure size	110x180x165mm Rittal Typ IP66 Box PK 9516 100, plastic	110x180x165mm Rittal Typ IP66 Box PK 9516 100, plastic
Input voltage	24Vdc	24Vdc
Load	24V, 8A; (=80%)	24V, 10A; (=100%)
Temperature inside the box	52.2°C	59.3°C
Temperature outside the box	31.0°C	31.4°C
Temperature rise	21.2K	27.9K

4.8 Mounting orientations

Mounting orientations other than input terminals on the bottom and output on the top require a reduction in continuous output power or a limitation in the maximum allowed ambient temperature.

The listed lifetime and MTBF values from this datasheet apply only for the standard mounting orientation.

The following curves give an indication for allowed output currents for altitudes up to 2000m.

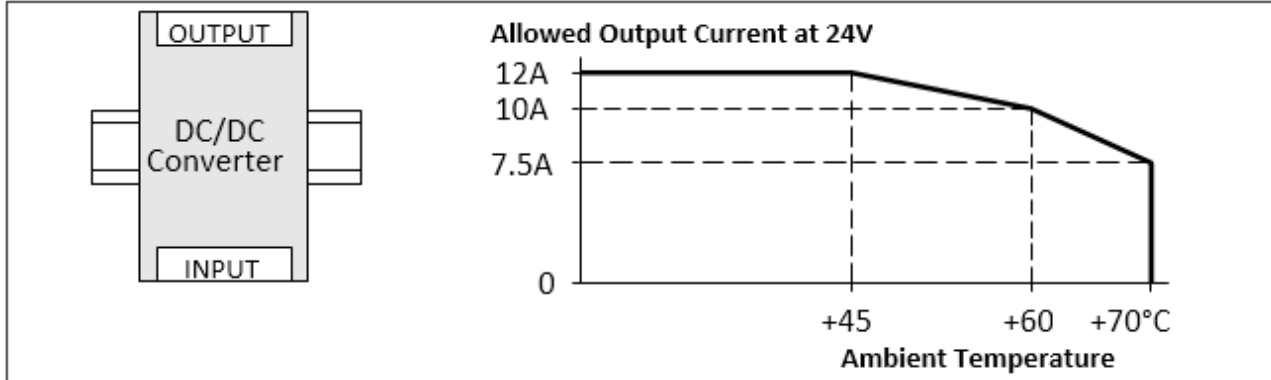

Fig. 22: Mounting position A (standard mounting position)

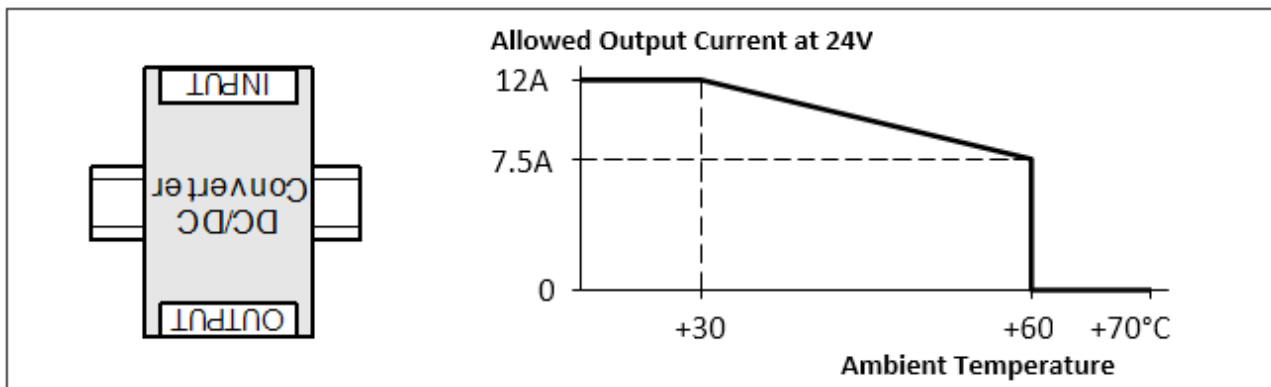

Fig. 23: Mounting position B (upside down)

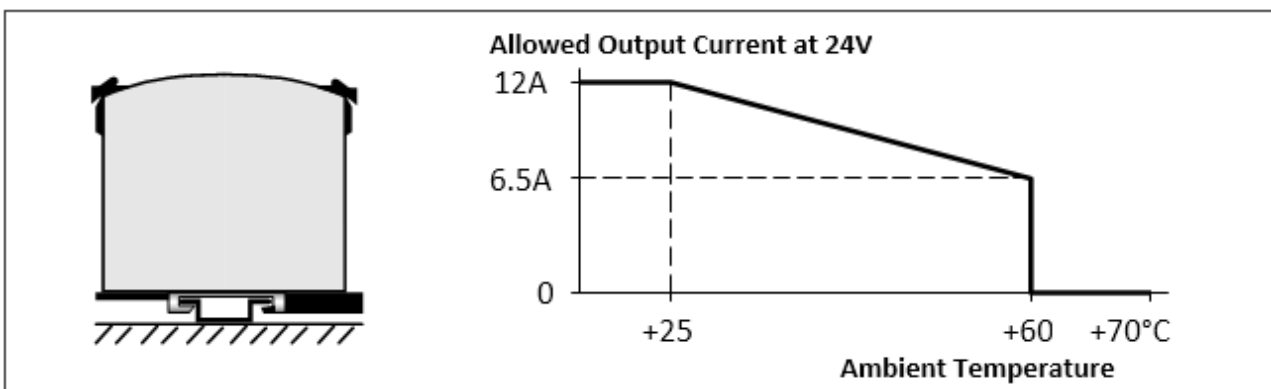

Fig. 24: Mounting position C (table-top mounting)

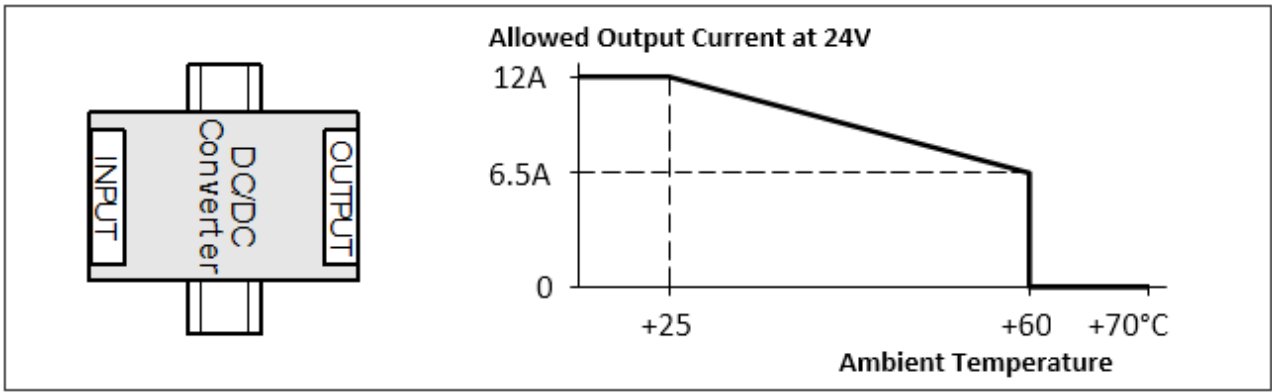

Fig. 25: Mounting position D (horizontal clockwise)

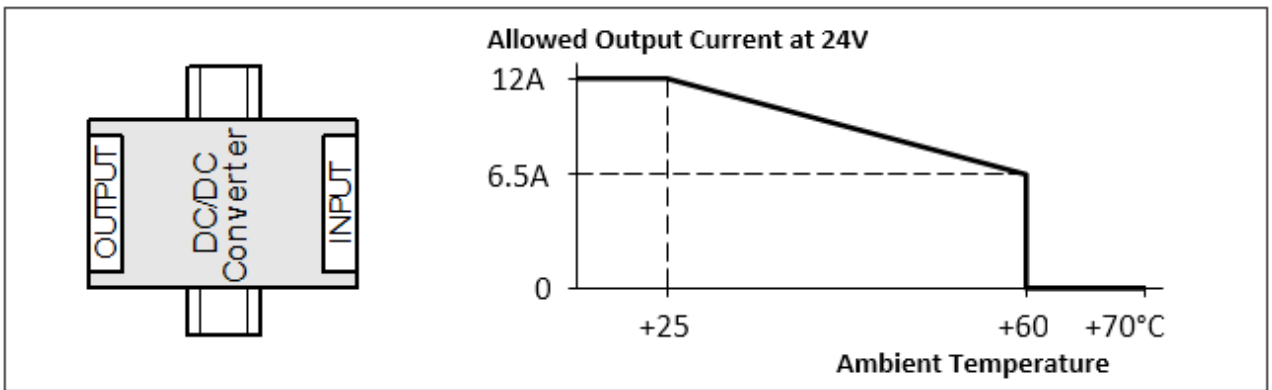

Fig. 26: Mounting position E (horizontal counterclockwise)

5 Disposal



Products marked with a crossed-out wheeled bin shall not be discarded with the normal waste stream. The device is considered as waste electrical and electronic equipment. The national regulations for the disposal of waste electrical and electronic equipment must be observed.

6 Appendix

6.1 Accessories

6.1.1 Redundancy and Buffer Modules

DC/DC converter	Accessories	
	Redundancy module	Buffer module
PS9711-2410-0000	PS9401-2440-0000	PS9011-2420-0001

PS9401-2440-0000– Redundancy Module



The PS9401-2440-0000 is a redundancy module that can be used for the construction of 1+1 and N+1 redundancy systems.

It has two input channels, to which power supplies with output currents of up to 20 A can be connected, and one output that can carry nominal currents of up to 40 A.

The redundancy module uses MOSFET technology instead of diodes for decoupling the two input channels. This reduces the heat development and the voltage drop between input and output. Due to the low power loss, the device is very narrow and requires a width of just 36 mm on the DIN rail. Large connection terminals enable secure and fast installation. The redundancy module requires no additional auxiliary voltage.

Due to the international approvals package, the device is suitable for virtually every application.

Observe the connection instructions in the chapter "[Parallel use for redundancy \[► 30\]](#)"!

PS9011-2420-0001 – Buffer Module



The PS9011-2420-0001 buffer module is an additional device for 24 V DC power supply units. It supplies power to bridge typical mains power failures or extends the hold-up time after switching off the AC voltage.

If the power supply unit supplies sufficient voltage, the buffer module stores energy in the integrated electrolytic capacitors. In the event of a failure of the mains voltage, the stored energy is supplied to the DC bus in a controlled process.

The buffer module can be connected at any point in parallel with the load circuit and does not require any control wiring.

A buffer module can provide 20 A of additional power and can be added in parallel to increase the output current or hold-up time.

The PS9011-2420-0001 buffer module can optionally be used to achieve longer hold-up times.

6.1.2 Accessories for mounting

ZS5301-0002 – Bracket for wall mounting

These brackets are used to mount the device on a flat surface or panel without utilizing a DIN-rail. The brackets can be mounted without detaching the DIN-rail brackets. The order number ZS5301-0002 contains two brackets needed for one device.

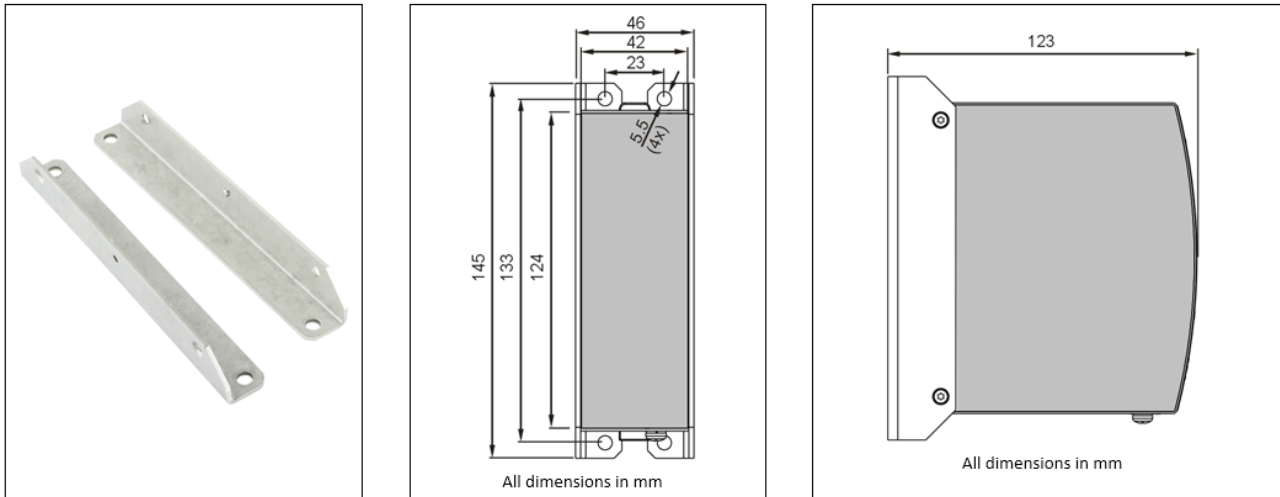

Fig. 27: ZS5301-0002; Hole pattern; Side view

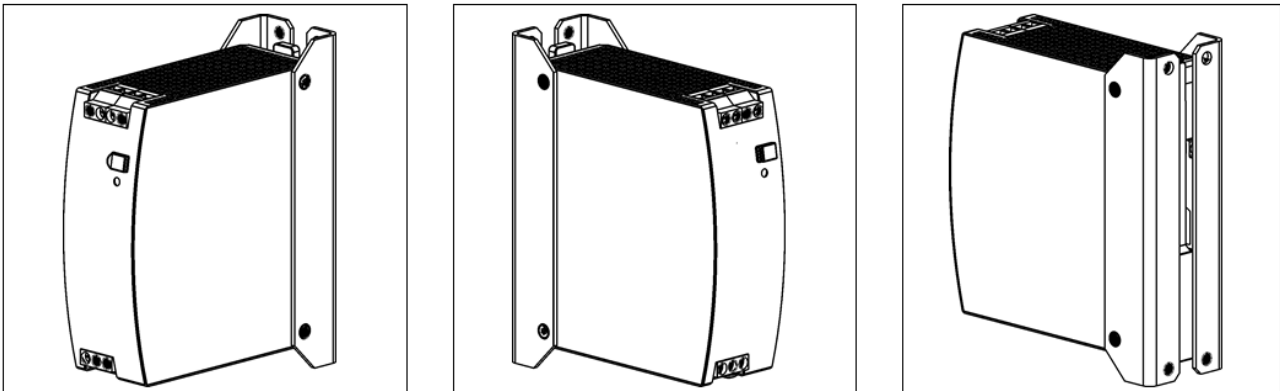

Fig. 28: Isometric view

ZS5301-0005 – Bracket for side mounting

This ZS5301-0005 bracket is used to mount the device sideways with or without utilizing a DIN-rail to save installation depth.

The two aluminum brackets and the black plastic slider of the unit have to be detached, so that the ZS5301-0005 steel bracket can be mounted.

For sideways DIN-rail mounting, the removed aluminum brackets and the black plastic slider need to be mounted on the ZS5301-0005 steel bracket.

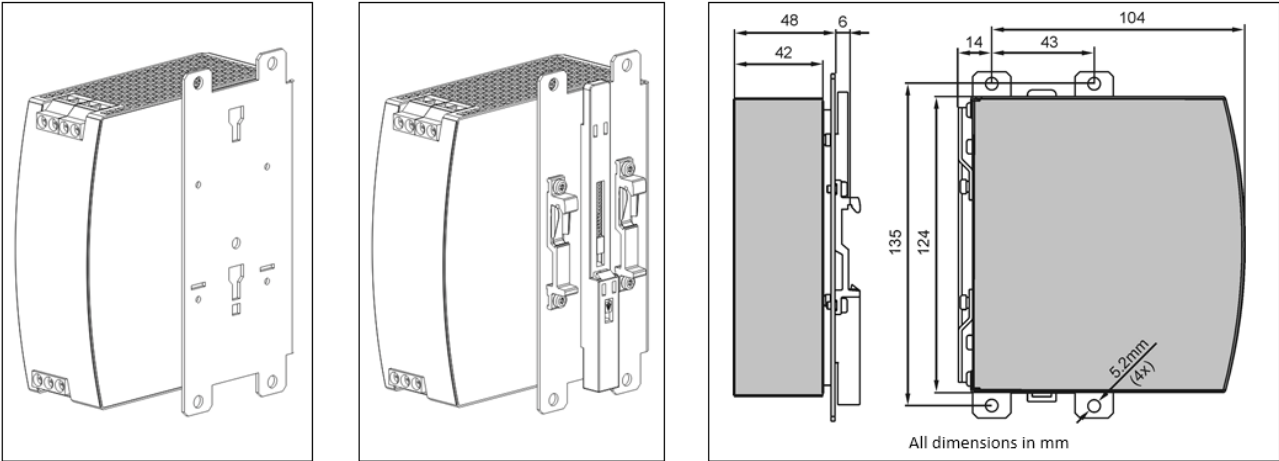

Side mounting without/with DIN-rail brackets; Hole pattern

6.2 Documentation issue status

Version	Comment
1.0	- 1 st public issue
0.1 – 0.6	- Preliminary documentation for PS9711-2410-0000

6.3 Support and Service

Beckhoff and their partners around the world offer comprehensive support and service, making available fast and competent assistance with all questions related to Beckhoff products and system solutions.

Beckhoff's branch offices and representatives

Please contact your Beckhoff branch office or representative for local support and service on Beckhoff products!

The addresses of Beckhoff's branch offices and representatives round the world can be found on her internet pages: www.beckhoff.com

You will also find further documentation for Beckhoff components there.

Support

The Beckhoff Support offers you comprehensive technical assistance, helping you not only with the application of individual Beckhoff products, but also with other, wide-ranging services:

- support
- design, programming and commissioning of complex automation systems
- and extensive training program for Beckhoff system components

Hotline: +49 5246 963 157
e-mail: support@beckhoff.com
web: www.beckhoff.com/support

Service

The Beckhoff Service Center supports you in all matters of after-sales service:

- on-site service
- repair service
- spare parts service
- hotline service

Hotline: +49 5246 963 460
e-mail: service@beckhoff.com
web: www.beckhoff.com/service

Headquarters Germany

Beckhoff Automation GmbH & Co. KG

Hülshorstweg 20
33415 Verl
Germany

Phone: +49 5246 963 0
e-mail: info@beckhoff.com
web: www.beckhoff.com

More Information:

www.beckhoff.com/ps9711-2410-0000

Beckhoff Automation GmbH & Co. KG
Hülshorstweg 20
33415 Verl
Germany
Phone: +49 5246 9630
info@beckhoff.com
www.beckhoff.com

