

M1600 Parallel Input / Output

Technical Documentation

BECKHOFF

INDUSTRIE ELEKTRONIK

Eiserstraße 5 phone 05246/709-0
33415 Verl fax 05246/70980

Table of Contents

1. Function Description Hardware.....	3
2. Function Description Software	5
3. Technical Data.....	6
4. Installation.....	7
5. Table of Connections	11

1. Function Description Hardware

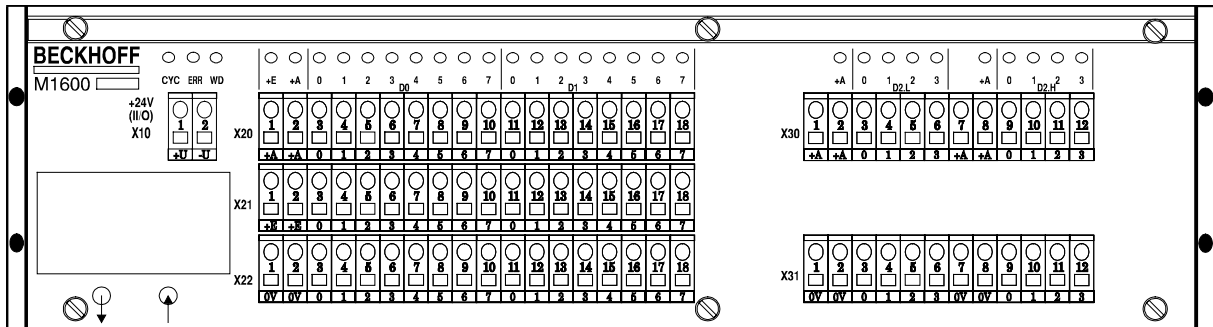

M1600

About the Hardware

The parallel module M1600 is an input / output module used in the II/O system. There are 16 Standard 24 V inputs / outputs and 8 high current outputs, which achieve 3 ports of 8 bit each.

These 3 ports (D0..D2) correspond to the data bytes in the FO transmissions protocol and according to the way they are to be used, the ports D0 and D1 can be configured as input or output.

Each input / output has an LED, that indicates the current state. Furthermore there are three LED's installed used for diagnosis of the II/O fibre optical ring:

- LD1** The green 'CYCLE' LED is switched on by each start bit of a telegram and is switched off again by the stop bit.
- LD2** The red 'ERROR' LED is switched on after the recognition of a bad telegram (checksum, frame). After a sequence of three correct telegrams (checksum, frame) were processed it is switched off again.
- LD3** The green LED 'WATCHDOG' is switched on by a valid writing telegram with matching address. If no telegram with the properties defined above is recognised for the next 100 ms a special unit of the module switches off all outputs.

In case an error is detected, all outputs are reset.

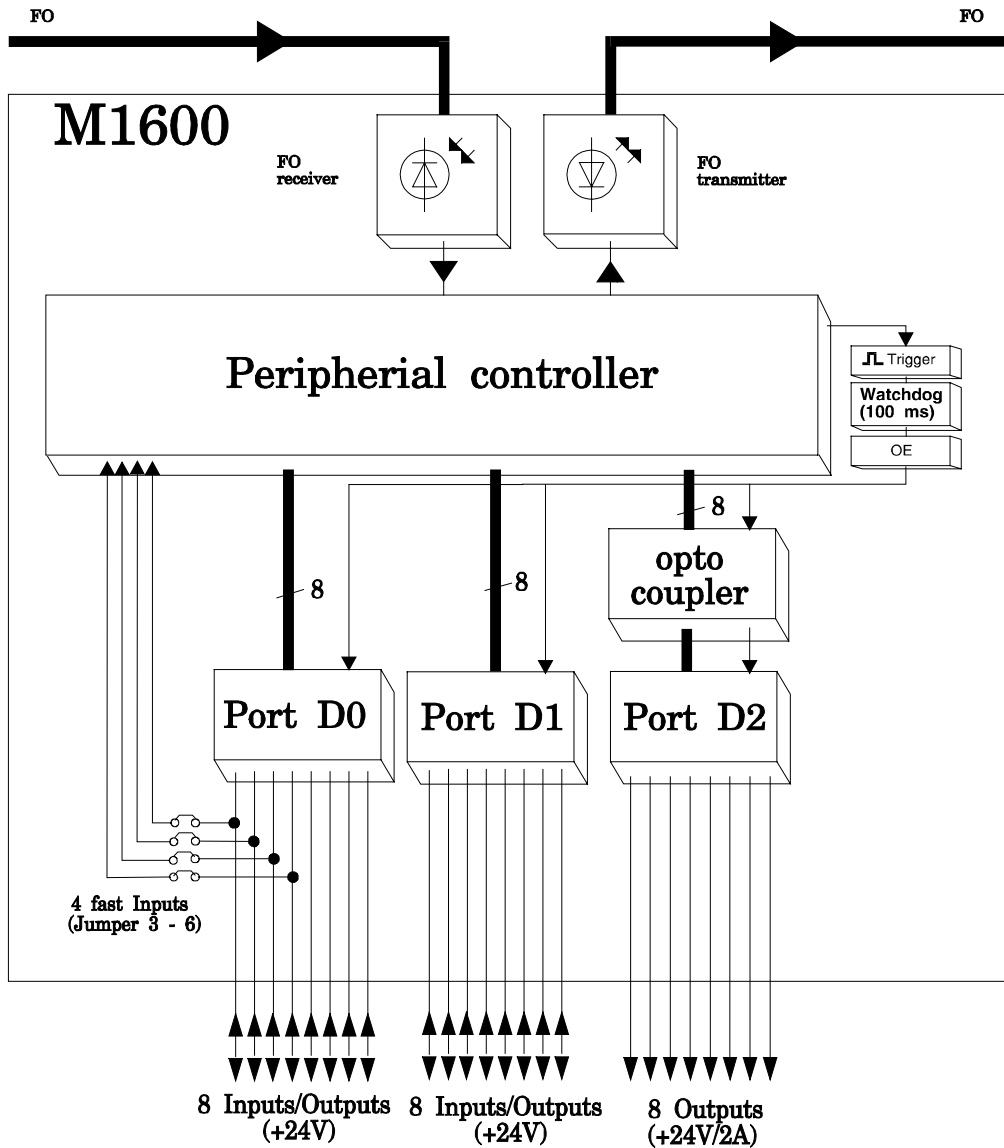

Basic Circuit Diagram

2. Function Description Software

3. Technical Data

Inputs / Outputs	16, can be configured for each port; 8 high current outputs LED shows state of all inputs / outputs
input specifications	24 VDC, 10 mA, digital filter
input switching voltages	0 - 8V = LOW 15 - 24V = HIGH
input delay	0,7 ms RC network 6,8 ms input latch
Output specifications	normal i/o : 24 VDC, max. 500 mA, short circuit proof High current : 24 VDC, max. 2 A, short circuit proof
Output check	watchdog system 100ms
Connections	can be connected for 16 I/O; +,-,signal and 8 high current outputs, +,-
Data connection	fibre optic II/O system
transmission rate	2,5 MBaud, 25 µs for 32 Bit
Supply Voltage	24 VDC (± 10%)
Input Current	0,1 A (without load and input currents)
Cartridge	closed, can be installed to cartridge carrier according to DIN EN 50022, 50035
Size (B * W * D)	270 * 76 * 68 mm
Weight	about 1100 g
Working Temperature	±0..+55 °C
Storage Temperature	-20..+70 °C

4. Installation

The M1600 is connected to the fibre optic ring using fibre optic connections (Toshiba). The maximum length of the FO cable, leading to the neighbouring boxes, should not be more than 600m for glass fibre or 45 meters for other fibres. These values are only valid if for bending the cable a radius of at least 30 mm is used. If there are no glass fibres used, no special tools are needed for installation of the plugs.

Common actors and sensor are connected directly to the inputs / outputs (using "+,-,signal").

The M1600 is installed at the machine or simply by installing it to a cartridge carrier according to DIN EN 50022 or DIN EN 50035.

Configuration

Each I/O port of the M1600 can be configured as input or as output. This does not depend on the configuration of the other ports. There are DIP switches under the XILINX board of the M1600. In order to change the state of the switches the module's cartridge has to be opened..

The DIP switches are assigned as follows:

switch 1	=>	port D0
switch 2	=>	port D1
switch 3	=>	port D2 must always be 'ON'
switch 4	NC,	set to 'ON'

It depends on the state of the switch whether a port is an output or an input :

'ON'	=>	port is output
'OFF'	=>	port is input

ATTENTION:

Configuring a port as input (switch "OFF") all of the eight output controller ICs of the port concerned have to be removed.

If the ICs are not removed the port is not functional as input, but the module remains undamaged.

configuration switch S

- 1 : ON = Port D0 is Output OFF = Port D0 is Input
- 2 : ON = Port D1 is Output OFF = Port D1 is Input
- 3 : ON must always be 'ON'**
- 4 : NC, set to 'ON'

Attention ! If a port is configured as an input the output driver ICs have to be removed.

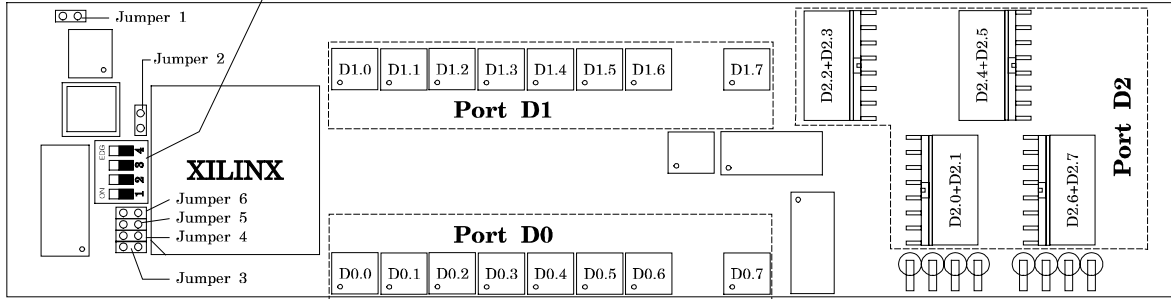

View under the M1600 XILINX board

The following module configuration is possible by setting jumpers 1 to 2 :

Jumper 1	<i>Watchdog on / off for Port D0 and D1</i>
	If this jumper is set the 'Watchdog' function is switched off. This means if an error is detected the outputs of Port D0 and D1 are not switched off. The security function for the high current outputs can not be disabled
Jumper 2	<i>Latch on / off</i>
	standard configuration is jumper 'set' inputs are latched in intervals of 6,8 ms otherwise inputs are latched permanently

The following modul configuration is possible by setting jumpers 3 to 6 :

	<i>Fast Inputs M1600 (Interrupt Inputs)</i>
Jumper 3	Fast input II3 : If jumper connection between port D0.3 and XILINX II3 is established Fast input is activated
Jumper 4	Fast input II2 : If jumper connection between port D0.2 and XILINX II3 is established Fast input is activated
Jumper 5	Fast input II1 : If jumper connection between port D0.1 and XILINX II3 is established Fast input is activated
Jumper 6	Fast input II0 : If jumper connection between port D0.0 and XILINX II3 is established Fast input is activated

Power Supply

There are the following connections for power supply :

- (1) two pole plug connection for the controller (X10 Pin1+2)
- (2) two pole plug connection for outputs (X20 Pin1+2)
(16 outputs)
- (3) two pole plug connection for inputs (X21 Pin1+2)
(16 inputs)
- (4) two pole plug connection for ground (X22 Pin1+2)
- (5) 2x two pole plug connection for 4 high current outputs (X30 Pin1+2 and Pin 7+8)
- (6) 2x two pole plug connection for 4 high current outputs (X31 Pin1+2 and Pin 7+8)

The power supply of the 8 high current channels is potential separated from the control logic unit. Thus the +24VDC lines and the 0V lines are connected separately.

The +24 VDC supply is established by two two-pin connections.

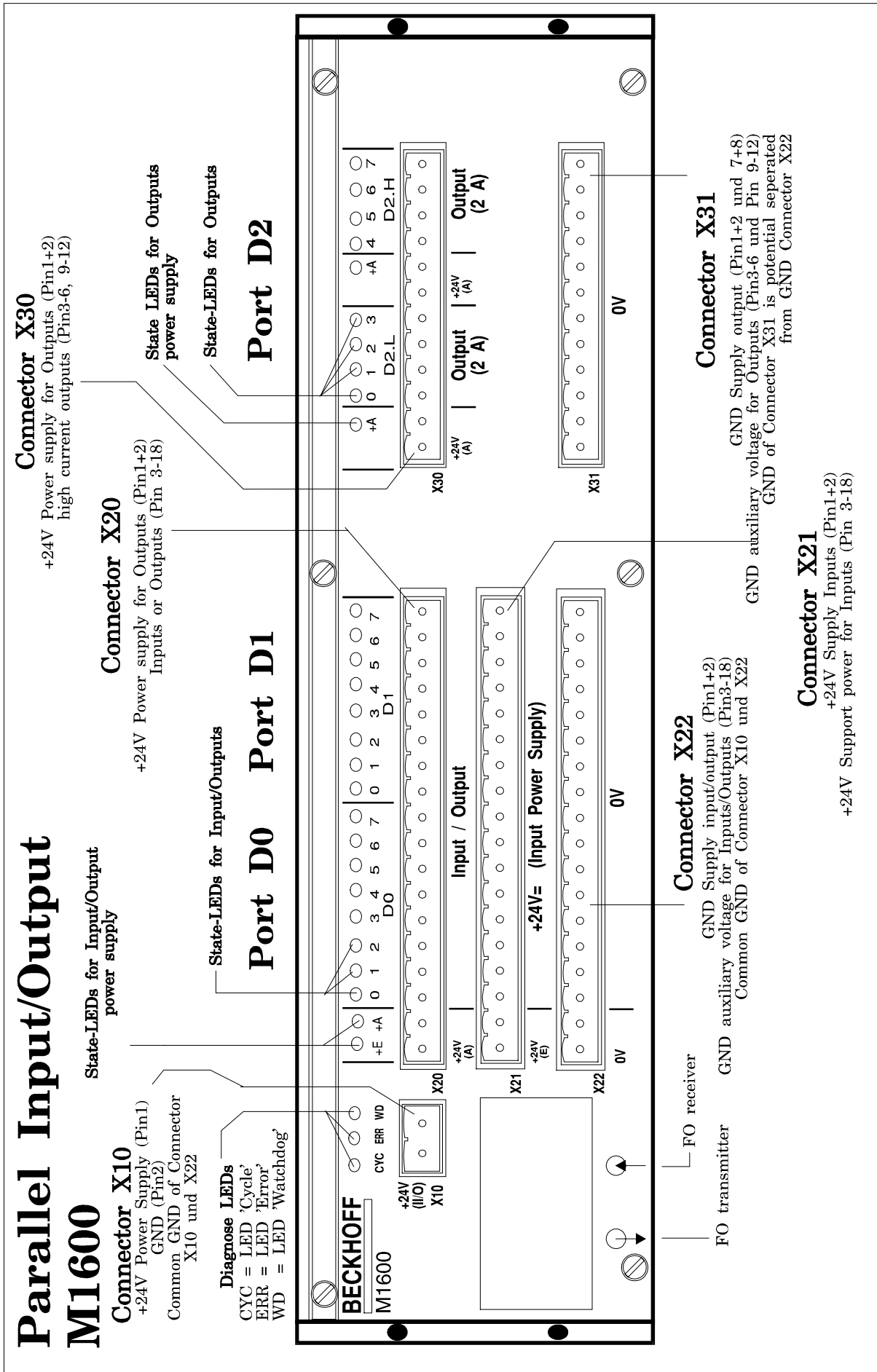

5. Table of Connections

Connector pin assignment with Signal Description

CONNECTOR X10

Connector	Pin	Signal	Description
X10	1	+U	+24V control power supply
X10	2	-U	GND ground

CONNECTOR X20

Connector	Pin	Signal	Description
X20	1	+A	+24V supply for output
X20	2	+A	+24V supply for output
X20	3	D0.0	Bit 0 of Data byte 0 D0.0 is output, if DIL switch S1 = ON D0.0 is input, if DIL switch S1 = OFF
X20	4	D0.1	Bit 1 of Data byte 0 D0.1 is output, if DIL switch S1 = ON D0.1 is input, if DIL-switch S1 = OFF
X20	5	D0.2	Bit 2 of Data byte 0 D0.2 is output, if DIL switch S1 = ON D0.2 is input, if DIL switch S1 = OFF
X20	6	D0.3	Bit 3 of Data byte 0 D0.3 is output, if DIL-switch S1 = ON D0.3 is input, if DIL switch S1 = OFF
X20	7	D0.4	Bit 4 of Data byte 0 D0.4 is output, if DIL switch S1 = ON D0.4 is input, of DIL switch S1 = OFF
X20	8	D0.5	Bit 5 of Data byte 0 D0.5 is output, if DIL switch S1 = ON D0.5 is input, if DIL switch S1 = OFF

continuation connector X20:

Connector	Pin	Signal	Description
X20	9	D0.6	Bit 6 of Data byte 0 D0.6 is output, if DIL switch S1 = ON D0.6 is input, if DIL switch S1 = OFF
X20	10	D0.7	Bit 7 of Data byte 0 D0.7 is output, if DIL switch S1 = ON D0.7 is input, if DIL switch S1 = OFF
X20	11	D1.0	Bit 0 of Data byte 1 D1.0 is output, if DIL switch S1 = ON D1.0 is input, if DIL switch S1 = OFF
X20	12	D1.1	Bit 1 of Data byte 1 D1.1 is output, if DIL switch S1 = ON D1.1 is input, if DIL switch S1 = OFF
X20	13	D1.2	Bit 2 of Data byte 1 D1.2 is output, if DIL switch S1 = ON D1.2 is input, if DIL switch S1 = OFF
X20	14	D1.3	Bit 3 of Data byte 1 D1.3 is output, if DIL switch S1 = ON D1.3 is input, if DIL switch S1 = OFF
X20	15	D1.4	Bit 4 of Data byte 1 D1.4 is output, if DIL switch S1 = ON D1.4 is input, if DIL switch S1 = OFF
X20	16	D1.5	Bit 5 of Data byte 1 D1.5 is output, if DIL switch S1 = ON D1.5 is input, if DIL switch S1 = OFF
X20	17	D1.6	Bit 6 of Data byte 1 D1.6 is output, if DIL switch S1 = ON D1.6 is input, if DIL switch S1 = OFF
X20	18	D1.7	Bit 7 of Data byte 1 D1.7 is output, if DIL switch S1 = ON D1.7 is input, if DIL switch S1 = OFF

CONNECTOR X21

Connector	Pin	Signal	Description
X21	1	+E	+24V supply inputs
X21	2	+E	+24V supply inputs
X21	3	+24V	+24V power supply for input 0.0
X21	4	+24V	+24V power supply for input 0.1
X21	5	+24V	+24V power supply for input 0.2
X21	6	+24V	+24V power supply for input 0.3
X21	7	+24V	+24V power supply for input 0.4
X21	8	+24V	+24V power supply for input 0.5
X21	9	+24V	+24V power supply for input 0.6
X21	10	+24V	+24V power supply for input 0.7
X21	11	+24V	+24V power supply for input 1.0
X21	12	+24V	+24V power supply for input 1.1
X21	13	+24V	+24V power supply for input 1.2
X21	14	+24V	+24V power supply for input 1.3
X21	15	+24V	+24V power supply for input 1.4
X21	16	+24V	+24V power supply for input 1.5
X21	17	+24V	+24V power supply for input 1.6
X21	18	+24V	+24V power supply for input 1.7

CONNECTOR X22

Connector	Pin	Signal	Description
X22	1	0V	GND Supply input/output
X22	2	0V	GND Supply input/output
X22	3	0V	GND Input/output D0.0
X22	4	0V	GND Input/output D0.1
X22	5	0V	GND Input/output D0.2
X22	6	0V	GND Input/output D0.3
X22	7	0V	GND Input/output D0.4
X22	8	0V	GND Input/output D0.5
X22	9	0V	GND Input/output D0.6
X22	10	0V	GND Input/output D0.7
X22	11	0V	GND Input/output D1.0
X22	12	0V	GND Input/output D1.1
X22	13	0V	GND Input/output D1.2
X22	14	0V	GND Input/output D1.3
X22	15	0V	GND Input/output D1.4
X22	16	0V	GND Input/output D1.5
X22	17	0V	GND Input/output D1.6
X22	18	0V	GND Input/output D1.7

CONNECTOR X30

Connector	Pin	Signal	Description
X30	1	+A	+24V supply for output
X30	2	+A	+24V supply for output
X30	3	D2.0	high current output Bit 0 of Data byte 2
X30	4	D2.1	high current output Bit 1 of Data byte 2
X30	5	D2.2	high current output Bit 2 of Data byte 2
X30	6	D2.3	high current output Bit 3 of Data byte 2
X30	7	+A	+24V supply for output
X30	8	+A	+24V supply for output
X30	9	D2.4	high current output Bit 4 of Data byte 2
X30	10	D2.5	high current output Bit 5 of Data byte 2
X30	11	D2.6	high current output Bit 6 of Data byte 2
X30	12	D2.7	high current output Bit 7 of Data byte 2

CONNECTOR X31

Connector	Pin	Signal	Description
X31	1	0V	GND Supply high current outputs
X31	2	0V	GND Supply high current outputs
X31	3	0V	GND high current output D2.0
X31	4	0V	GND high current output D2.1
X31	5	0V	GND high current output D2.2
X31	6	0V	GND high current output D2.3
X31	7	0V	GND Supply high current outputs
X31	8	0V	GND Supply high current outputs
X31	9	0V	GND high current output D2.4
X31	10	0V	GND high current output D2.5
X31	11	0V	GND high current output D2.6
X31	12	0V	GND high current output D2.7

Common GND of Connector X10 Pin 2 and Connector X22 Pin 1 to 18.

GND (Connector X31 Pin 1 to 12) is potential separated from GND (Connector X22 Pin 1 to 18).