

# M1410 Parallel Input / Output

## Technical Documentation

# **BECKHOFF**

**INDUSTRIE ELEKTRONIK**

Eiserstraße 5      phone 05246/709-0  
33415 Verl          fax 05246/70980

## Table of Contents

<b>1. Function Description Hardware.....</b>	<b>3</b>
<b>2. Function Description Software .....</b>	<b>5</b>
<b>3. Technical Data.....</b>	<b>6</b>
<b>4. Installation.....</b>	<b>7</b>
<b>5. Table of Connections .....</b>	<b>11</b>

## 1. Function Description Hardware

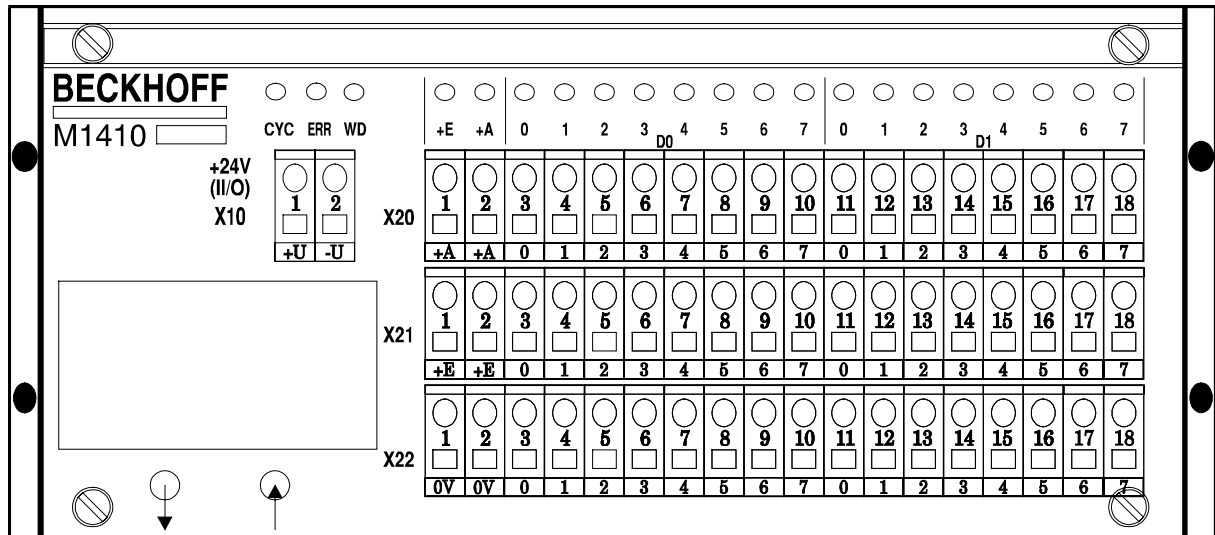

*M1410*

### About the Hardware

The parallel module M1410 is an input / output module used in the II/O system. There are 16 Standard 24 V inputs / outputs, which achieve 2 ports of 8 bit each.

These 2 ports ( D0,D1 ) correspond to the data bytes in the FO transmissions protocol and according to the way they are to be used, they can be configured as input or output.

Each input / output has an LED, that indicates the current state. Furthermore there are three LED's installed used for diagnosis of the II/O fibre optical ring:

- LD1** The green 'CYCLE' LED is switched on by each start bit of a telegram and is switched off again by the stop bit.
- LD2** The red 'ERROR' LED is switched on after the recognition of a bad telegram (checksum, frame). After a sequence of three correct telegrams (checksum, frame) were processed it is switched off again.
- LD3** The green LED 'WATCHDOG' is switched on by a valid writing telegram with matching address. If no telegram with the properties defined above is recognised for the next 100 ms a special unit of the module switches off all outputs.

In case an error is detected, all outputs are reset.

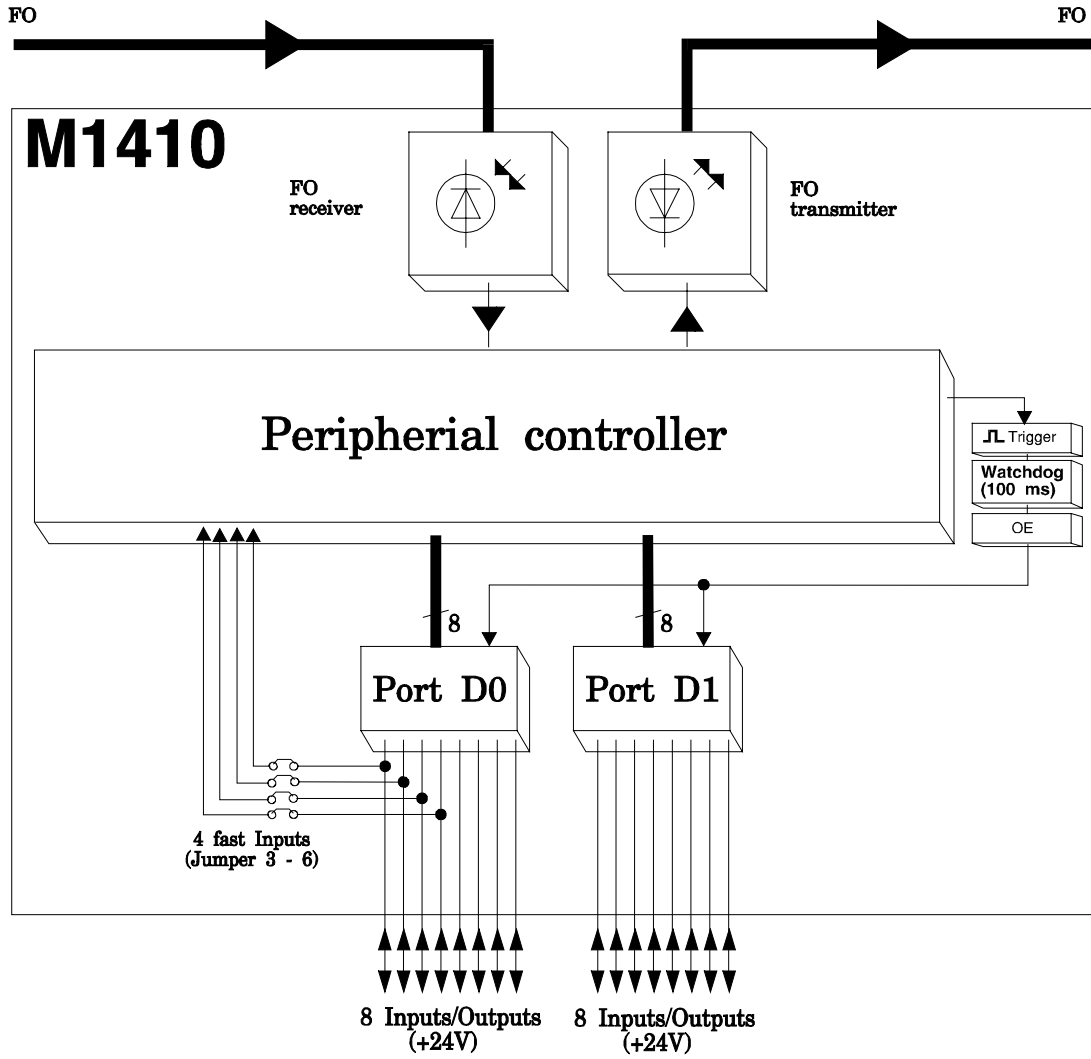

*Basic Circuit Diagram*

## **2. Function Description Software**

### 3. Technical Data

<b>Inputs / Outputs</b>	16, can be configured for each port; LED shows state of all inputs / outputs
<b>Input Specifications</b>	24 VDC, 10 mA, digital filter
<b>input switching voltages</b>	0 - 8V = LOW 15 - 24V = HIGH
<b>input delay</b>	0,7 ms RC network 6,8 ms input latch
<b>Output Specifications</b>	24 VDC, max. 500 mA, short circuit proof
<b>Output check</b>	watchdog system 100ms
<b>Connections</b>	can be connected for 16 I/O; +,-,signal
<b>Data Connection</b>	fibre optic II/O system
<b>Transmission Rate</b>	2,5 MBaud, 25 µs for 32 Bit
<b>Supply Voltage</b>	24 VDC (± 10%)
<b>Input Current</b>	0,1 A (without load and input currents)
<b>Cartridge</b>	closed, can be installed to cartridge carrier according to DIN EN 50022, 50035
<b>Size (B * W * D)</b>	170 * 76 * 68 mm
<b>Weight</b>	about 700 g
<b>Working Temperature</b>	±0..+55 °C
<b>Storage Temperature</b>	-20..+70 °C

## 4. Installation

The M1410 is connected to the fibre optic ring using fibre optic connections (Toshiba). The maximum length of the FO cable, leading to the neighbouring boxes, should not be more than 600m for glass fibre or 45 meters for other fibres. These values are only valid, if for bending the cable a radius of at least 30 mm is used. If there are no glass fibres used, no special tools are needed for installation of the plugs.

Common actors and sensor are connected directly to the inputs / outputs (using "+,-,signal" ).

The M1410 is installed at the machine or simply by installing it to a cartridge carrier according to DIN EN 50022 or DIN EN 50035.

## Configuration

Each I/O port of the M1410 can be configured as input or as output. This does not depend on the configuration of the other ports. There are DIP switches under the XILINX board of the M1410. In order to change the state of the switches the module's cartridge has to be opened..

The DIP switches are assigned as follows:

switch 1	=>	port D0
switch 2	=>	port D1
switch 3	NC,	no connectet, set to 'ON'
switch 3	NC,	no connectet, set to 'ON'

It depends on the state of the switch whether a port is output or input :

- 'ON' => port is output
- 'OFF' => port is input

**ATTENTION:**  
**Configuring a port as input ( switch "OFF") all of the eight output controller ICs of the port concerned have to be removed.**  
 If the ICs are not removed the port is not functional as input, but the module remains undamaged.

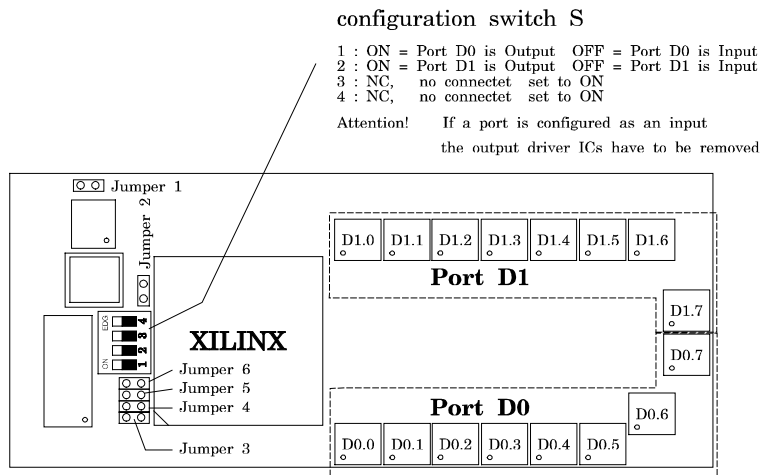

*View the M1410 XILINX board*

The following module configuration is possible by setting jumpers 1 to 2:

Jumper 1	<b><i>Watchdog on / off for Port D0 and D1</i></b>
	If this jumper is set the 'Watchdog' function is switched off. This means if an error is detected the outputs set of Port D0 and D1 are not switched off.
Jumper 2	<b><i>Latch on / off</i></b>
	standard configuration is jumper 'set' input are latched in intervals of 6,8 ms otherwise inputs are latched permanently



The following module configuration is possible by setting jumpers 3 to 6:

	<b><i>Fast Inputs M1410</i></b> (Interrupt Inputs)
Jumper 3	Fast input II3 : If jumper connection between port D0.3 and XILINX II3 is established Fast input is activated
Jumper 4	Fast input II2 : If jumper connection between port D0.2 and XILINX II3 is established Fast input is activated
Jumper 5	Fast input II1 : If jumper connection between port D0.1 and XILINX II3 is established Fast input is activated
Jumper 6	Fast input II0 : If jumper connection between port D0.0 and XILINX II3 is established Fast input is activated

## Power Supply

There are the following connections for power Supply :

- (1) two pole plug connection for the controller (X10 Pin1+2)
- (2) two pole plug connection for outputs (X20 Pin1+2)  
( 16 outputs )
- (3) two pole plug connection for inputs X21 Pin1+2)  
(16 inputs)
- (4) two pole plug connection for ground (X22 Pin1+2)

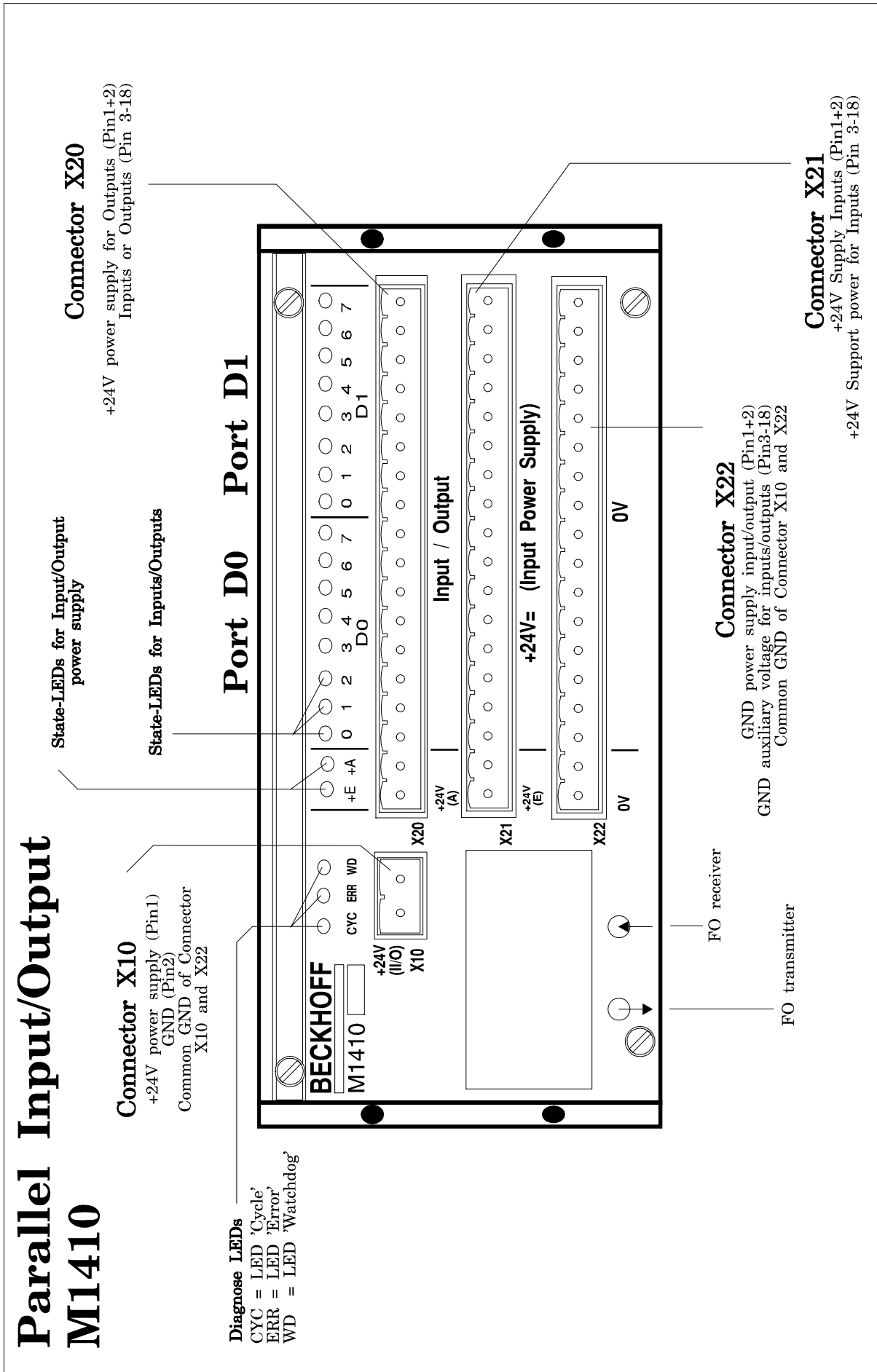

## 5. Table of Connections

### Connector pin assignment with Signal Description

#### CONNECTOR X10

Connector	Pin	Signal	Description
X10	1	+U	+24V control power supply
X10	2	-U	GND ground

#### CONNECTOR X20

Connector	Pin	Signal	Description
X20	1	+A	+24V supply for output
X20	2	+A	+24V supply for output
X20	3	D0.0	Bit 0 of Data byte 0 D0.0 is output, if DIL switch S1 = ON D0.0 is input, if DIL switch S1 = OFF
X20	4	D0.1	Bit 1 of Data byte 0 D0.1 is output, if DIL switch S1 = ON D0.1 is input, if DIL-switch S1 = OFF
X20	5	D0.2	Bit 2 of Data byte 0 D0.2 is output, if DIL switch S1 = ON D0.2 is input, if DIL switch S1 = OFF
X20	6	D0.3	Bit 3 of Data byte 0 D0.3 is output, if DIL-switch S1 = ON D0.3 is input, if DIL switch S1 = OFF
X20	7	D0.4	Bit 4 of Data byte 0 D0.4 is output, if DIL switch S1 = ON D0.4 is input, of DIL switch S1 = OFF
X20	8	D0.5	Bit 5 of Data byte 0 D0.5 is output, if DIL switch S1 = ON D0.5 is input, if DIL switch S1 = OFF

continuation connector X20:

Connector	Pin	Signal	Description
X20	9	D0.6	Bit 6 of Data byte 0 D0.6 is output, if DIL switch S1 = ON D0.6 is input, if DIL switch S1 = OFF
X20	10	D0.7	Bit 7 of Data byte 0 D0.7 is output, if DIL switch S1 = ON D0.7 is input, if DIL switch S1 = OFF
X20	11	D1.0	Bit 0 of Data byte 1 D1.0 is output, if DIL switch S1 = ON D1.0 is input, if DIL switch S1 = OFF
X20	12	D1.1	Bit 1 of Data byte 1 D1.1 is output, if DIL switch S1 = ON D1.1 is input, if DIL switch S1 = OFF
X20	13	D1.2	Bit 2 of Data byte 1 D1.2 is output, if DIL switch S1 = ON D1.2 is input, if DIL switch S1 = OFF
X20	14	D1.3	Bit 3 of Data byte 1 D1.3 is output, if DIL switch S1 = ON D1.3 is input, if DIL switch S1 = OFF
X20	15	D1.4	Bit 4 of Data byte 1 D1.4 is output, if DIL switch S1 = ON D1.4 is input, if DIL switch S1 = OFF
X20	16	D1.5	Bit 5 of Data byte 1 D1.5 is output, if DIL switch S1 = ON D1.5 is input, if DIL switch S1 = OFF
X20	17	D1.6	Bit 6 of Data byte 1 D1.6 is output, if DIL switch S1 = ON D1.6 is input, if DIL switch S1 = OFF
X20	18	D1.7	Bit 7 of Data byte 1 D1.7 is output, if DIL switch S1 = ON D1.7 is input, if DIL switch S1 = OFF

**CONNECTOR X21**

Connector	Pin	Signal	Description
X21	1	+E	+24V supply inputs
X21	2	+E	+24V supply inputs
X21	3	+24V	+24V power supply for input 0.0
X21	4	+24V	+24V power supply for input 0.1
X21	5	+24V	+24V power supply for input 0.2
X21	6	+24V	+24V power supply for input 0.3
X21	7	+24V	+24V power supply for input 0.4
X21	8	+24V	+24V power supply for input 0.5
X21	9	+24V	+24V power supply for input 0.6
X21	10	+24V	+24V power supply for input 0.7
X21	11	+24V	+24V power supply for input 1.0
X21	12	+24V	+24V power supply for input 1.1
X21	13	+24V	+24V power supply for input 1.2
X21	14	+24V	+24V power supply for input 1.3
X21	15	+24V	+24V power supply for input 1.4
X21	16	+24V	+24V power supply for input 1.5
X21	17	+24V	+24V power supply for input 1.6
X21	18	+24V	+24V power supply for input 1.7

**CONNECTOR X22**

Connector	Pin	Signal	Description
X22	1	0V	GND Supply input/output
X22	2	0V	GND Supply input/output
X22	3	0V	GND Input/output D0.0
X22	4	0V	GND Input/output D0.1
X22	5	0V	GND Input/output D0.2
X22	6	0V	GND Input/output D0.3
X22	7	0V	GND Input/output D0.4
X22	8	0V	GND Input/output D0.5
X22	9	0V	GND Input/output D0.6
X22	10	0V	GND Input/output D0.7
X22	11	0V	GND Input/output D1.0
X22	12	0V	GND Input/output D1.1
X22	13	0V	GND Input/output D1.2
X22	14	0V	GND Input/output D1.3
X22	15	0V	GND Input/output D1.4
X22	16	0V	GND Input/output D1.5
X22	17	0V	GND Input/output D1.6
X22	18	0V	GND Input/output D1.7

