

Operating instructions for

# KL3311, KL3312, KL3314 and KL3302

Single-, Two- and Four-Channel Analog Input Terminals  
for Thermocouples

Version: 3.4  
Date: 2008-05-19

**BECKHOFF**

# Table of contents

<b>1. Foreword</b>	<b>1</b>
Notes on the documentation	1
Safety Instructions	2
<b>2. Technical data</b>	<b>3</b>
<b>3. Connection</b>	<b>3</b>
KL3311	3
KL3312 (KL3302)	4
KL3314	4
<b>4. Functional description</b>	<b>5</b>
<b>5. Terminal configuration</b>	<b>8</b>
<b>6. Register Description</b>	<b>9</b>
General Description of Registers	9
Terminal-specific register description	12
Control and Status byte	14
Register communication	15
<b>7. Appendix</b>	<b>17</b>
Mapping	17
Register Table	20
Support and Service	21

# Foreword

## Notes on the documentation

This description is only intended for the use of trained specialists in control and automation engineering who are familiar with the applicable national standards. It is essential that the following notes and explanations are followed when installing and commissioning these components.

### Liability Conditions

The responsible staff must ensure that the application or use of the products described satisfy all the requirements for safety, including all the relevant laws, regulations, guidelines and standards.

The documentation has been prepared with care. The products described are, however, constantly under development. For that reason the documentation is not in every case checked for consistency with performance data, standards or other characteristics. None of the statements of this manual represents a guarantee (Garantie) in the meaning of § 443 BGB of the German Civil Code or a statement about the contractually expected fitness for a particular purpose in the meaning of § 434 par. 1 sentence 1 BGB. In the event that it contains technical or editorial errors, we retain the right to make alterations at any time and without warning. No claims for the modification of products that have already been supplied may be made on the basis of the data, diagrams and descriptions in this documentation.

### Delivery conditions

In addition, the general delivery conditions of the company Beckhoff Automation GmbH apply.

### Copyright

© This documentation is copyrighted. Any reproduction or third party use of this publication, whether in whole or in part, without the written permission of Beckhoff Automation GmbH, is forbidden.

# Safety Instructions

## State at Delivery

All the components are supplied in particular hardware and software configurations appropriate for the application. Modifications to hardware or software configurations other than those described in the documentation are not permitted, and nullify the liability of Beckhoff Automation GmbH.

## Description of safety symbols

The following safety symbols are used in this documentation. They are intended to alert the reader to the associated safety instructions..



**Danger**

This symbol is intended to highlight risks for the life or health of personnel.



**Attention**

This symbol is intended to highlight risks for equipment, materials or the environment.



**Note**

This symbol indicates information that contributes to better understanding.

# Technical data

Technical data	KL3311	KL3302*	KL3312	KL3314
Number of inputs	1	2	2	4
Power supply	via the K-Bus			
Thermocouple sensor type	Types J, K, L, B, E, N, R, S, T, U (default setting type K), mV measurement			
Connection	2 wire			
Temperature range	within the respective defined range of the sensor (Default: type K; -100° ... 1370°C)			
Resolution	0.1°C per digit			
Broken lead detection	yes	no	yes	yes
Conversion time	~ 200 ms	~ 250 ms		
Meas. error (total meas. range)	< ± 0.5% (of the full scale value)			
Electrical isolation	500 V <sub>rms</sub> (K-Bus/signal voltage)			
Current consumption from K-Bus	typically 65 mA			
Bits width in process image	Input: 1 x 16 bits of data (1 x 8 bits control/status optional)	Input: 2 x 16 bits of data (2 x 8 bits control/status optional)	Input: 4 x 16 bits of data (4 x 8 bits control/status optional)	
Configuration	no address setting, configuration via bus coupler or controller			
Weight	approx. 70 g			
Operating temperature	0°C ... +55°C			
Storage temperature	-25°C ... +85°C			
Relative humidity	95 % no condensation			
Vibration / shock resistance	according to EN 60068-2-6 / EN 60068-2-27, EN 60068-2-29			
EMC resistance burst / ESD	according to EN 61000-6-2 / EN 61000-6-4			
Installation position	any			
Protection class	IP20			

\*) KL3302 is no longer available and was replaced with KL3312.

## Connection KL3311

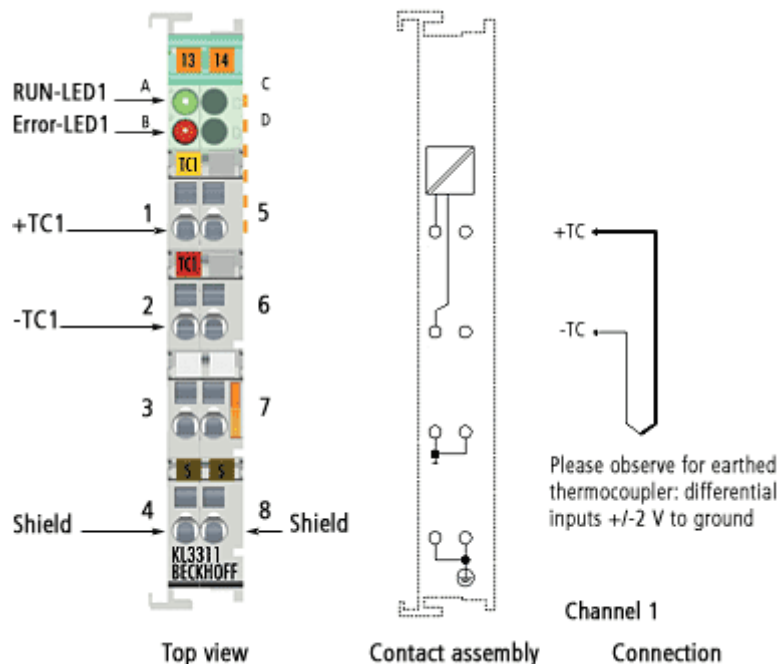

## KL3312 (KL3302)

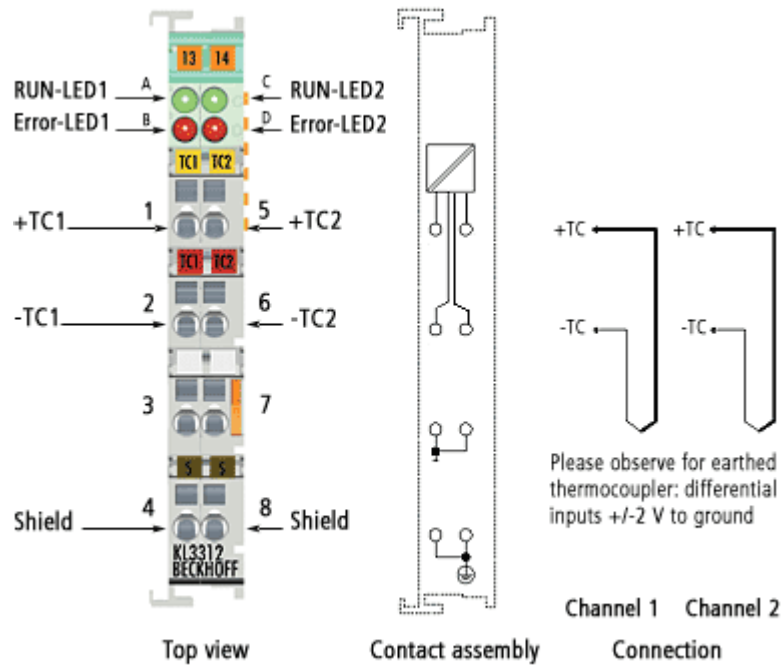

## KL3314

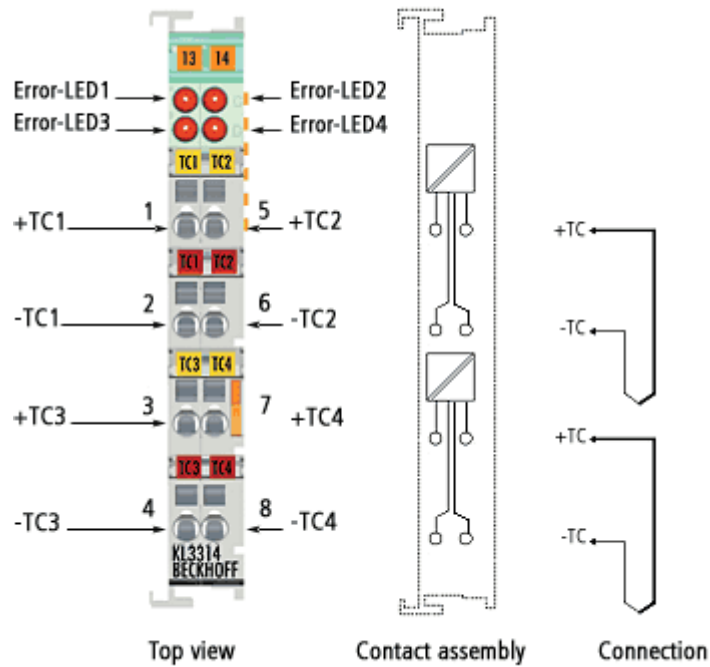

## Functional description

The thermocouple terminals KL3311, KL3302 (without broken wire detection), KL3312 and KL3314 can evaluate type J, K, B, E, N, R, S, T, U and L thermocouples. The characteristic curves are linearized and the reference temperature determined directly within the terminal. Temperatures are output in 1/10°C. The terminal is fully configurable via the Bus Coupler or the control. Different output formats may be selected or own scaling activated. In addition, linearization of the characteristic curve and determination and calculation of the reference temperature (temperature at the terminal connection contacts) can be switched off.

### Functioning

Thermocouples can be classified as active measuring sensors. They exploit the thermo-electric effect (Seebeck, Peltier, Thomson). Where two electrical conductors of different materials (e.g. iron and constantan) make contact, charge is transferred across the contact surface. A contact potential develops, and is strongly dependent on temperature. The thermally generated voltage is both a function of the temperature being measured,  $T$ , and of the reference temperature,  $T_v$ , at the point where contact is made with the thermocouple. Since the coefficients are determined at a reference temperature of 0°C, it is necessary to compensate for the effect of the reference temperature. This is done by converting the reference temperature into a reference voltage that depends on the type of thermocouple, and adding this to the measured thermal voltage. The temperature is found from the resulting voltage and the corresponding curve.

$$U_k = U_{\text{meas}} + U_{\text{ref}}$$

$$T_{\text{aus}} = f(U_k)$$

### Process data output format

In the delivery state, the measured value is displayed in increments of 1/10 °C in two's complement format (integer). Other display types can be selected via the feature register (e.g. sign/amount representation, Siemens output format).

Measured value	Hexadecimal output	Signed integer output
-200.0°C	0xF830	-2000
-100.0°C	0xFC18	-1000
-0.1°C	0xFFFF	-1
0.0°C	0x0000	0
0.1°C	0x0001	1
100.0°C	0x03E8	1000
200.0°C	0x07D0	2000
500.0°C	0x1388	5000
850.0°C	0x2134	8500
1,000.0°C	0x2710	10000

### Voltage limits

$U_k > U_{k\text{max}}$ : Bits 1 and 6 (over range and error bits) in the status byte are set. The linearization of the characteristic curve is continued with the coefficients of the upper range limit up to the limit stop of the A/D converter or to the maximum value of 0x7FFF.

$U_k < U_{kmin}$ : Bits 0 and 6 (under range and error bits) in the status byte are set. The linearization of the characteristic curve is continued with the coefficients of the lower range limit up to the limit stop of the A/D converter or to the minimum value of 0x8000.

For over range or under range the red error LED is switched on.

## LED display

The four LEDs indicate the operating state of the associated terminal channels.

Green LEDs: RUN (not applicable for KL3314)

- On: normal operation
- Off: Watchdog-timer overflow has occurred. If no process data are transmitted by the Bus Coupler for 100 ms, the green LEDs go out.

Red LEDs: ERROR

- On: Wire breakage. The resistance is in the invalid range of the characteristic curve of the respective thermocouple.
- Off: The resistance is in the valid range of the characteristic curve.

## Process data

The process data that are transferred to the terminal bus are calculated using the following equations:

$X_{ref}$ :	ADC value of the reference point
$T_{ref}$ :	Temperature of the reference point
$U_{ref}$ :	Voltage value of the reference point
$X_R$ :	ADC value of the temperature sensor
$U_{m1}$ :	Voltage value of the temperature sensor
$A_a, B_a$ :	Manufacturer gain and offset compensation (R17, R18)
$A_h, B_h$ :	Manufacturer scaling
$A_w, B_w$ :	User scaling
$U_k$ :	Sum of $U_{ref}$ and $U_{m1}$
$T$ :	Measured temperature in 1/16 °C
$T_h$ :	Temperature after manufacturer scaling (1/10 °C)
$T_a$ :	Temperature after user scaling
$T_{AUS}$ :	Process data to PLC

a) Voltage value of the reference point:

$$T_{ref} = A_{00} * X_{ref} \quad (1.0)$$

$$U_{ref} = a_1 * T_{ref}^2 + b_1 * T_{ref} + c_1 \quad (1.1)$$

b) Measured temperature in 1/16°C:

$$U_{m1} = A_a * X_m + B_a \quad (1.2)$$

$$U_k = U_{ref} + U_{m1} \quad (1.3)$$

$$T = a_0 * U_k^2 + b_0 * U_k + c_0 \quad (1.4)$$

c) Neither user nor manufacturer scaling are active:

$$T_{AUS} = T \quad (1.5)$$

d) Manufacturer scaling active (factory setting):

$$T_h = A_h * T + B_h \quad (1.6)$$

$$Y_{AUS} = T_h$$

e) User scaling active:

$$T_a = A_w * T + B_w \quad (1.7)$$

$$Y_{AUS} = T_a$$

f) Manufacturer and user scaling active: (1.8)

$$Y_1 = A_h * T + B_h$$

$$Y_2 = A_w * Y_1 + B_w$$

$$Y_{AUS} = Y_2$$



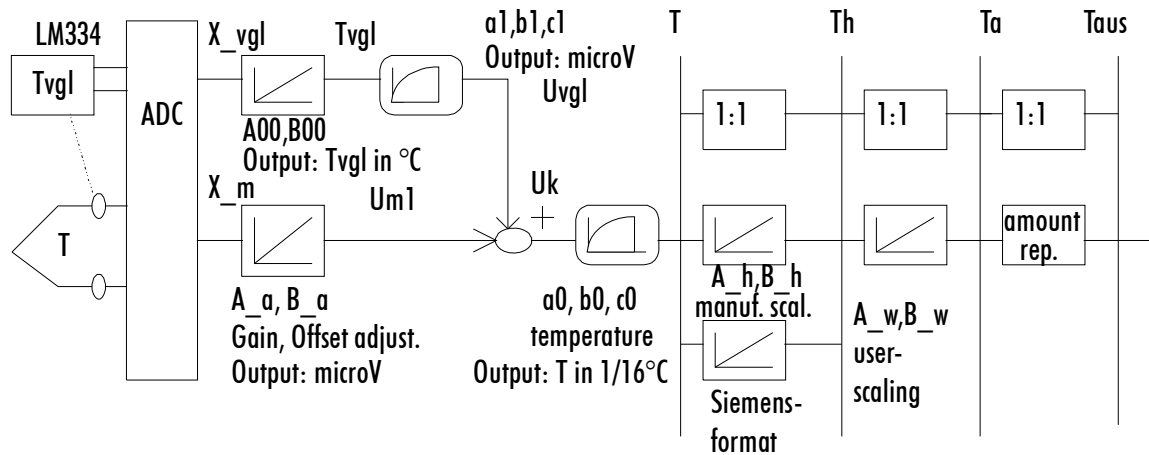

Connection

Due to the differential inputs of the terminals, different connection types are recommended depending on the type of thermocouple used. For earthed thermocouples, ground is connected to the screen. If the thermocouple has no earth connection, the ground, screen and -TC1 or -TC2 contacts are connected with each other.

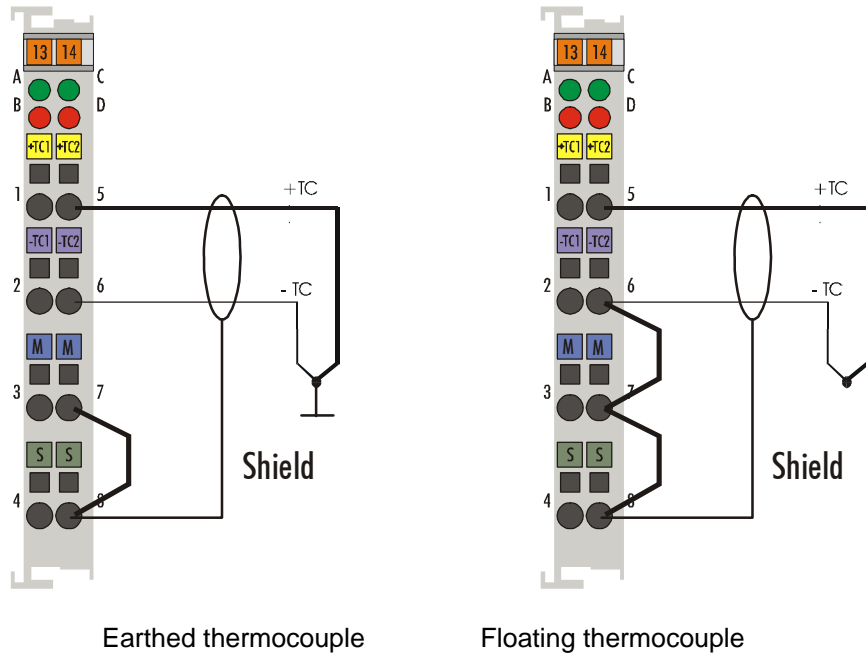

The examples show the situation for KL3312. For the KL3314, the screen should be connected to an additional screen terminal (KL9195).

# Terminal configuration

The terminals can be configured and parameterized via the internal register structure. Each terminal channel is mapped in the Bus Coupler. Depending on the type of the Bus Coupler and the mapping configuration (e.g. Motorola/Intel format, word alignment etc.) the terminal data are mapped in different ways to the Bus Coupler memory. For parameterizing a terminal, the control and status byte also has to be mapped.

## BK2000 Lightbus Coupler

In the BK2000 Lightbus coupler, the control and status byte is mapped in addition to the data bytes. This is always located in the low byte at the offset address of the terminal channel.

Example for KL3312 (KL3302):

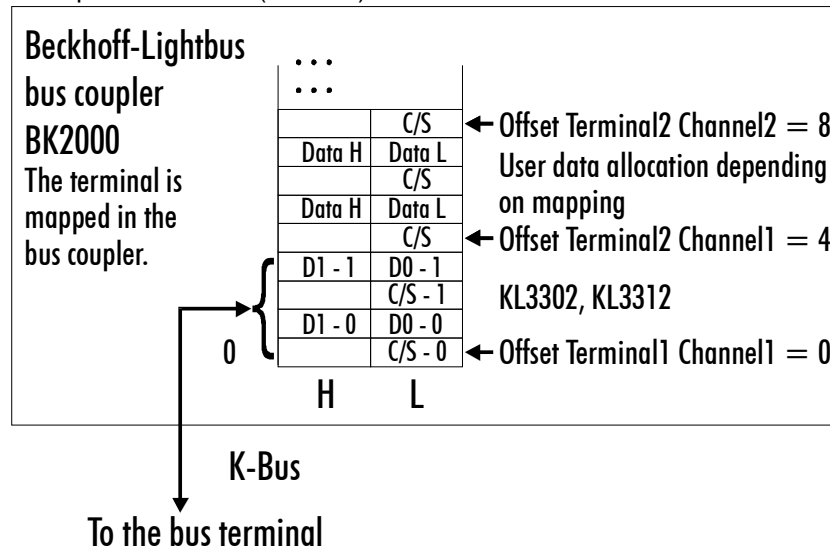

## BK3000 PROFIBUS coupler

For the BK3000 PROFIBUS coupler, the master configuration should specify for which terminal channels the control and status byte is to be inserted. If the control and status byte are not evaluated, the terminals occupy 2 bytes per channel:

- KL3311: 2 bytes of input data
- KL3312 (KL3302): 4 bytes of input data
- KL3314: 8 bytes of input data

Example for KL3312 (KL3302):

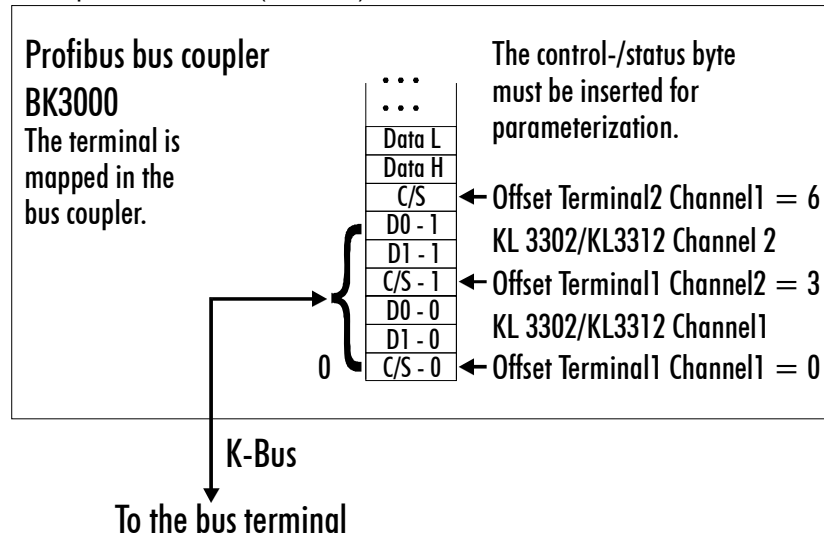

BK4000 Interbus Coupler

The BK4000 Interbus Coupler maps the terminals in the delivery state with 2 bytes per channel:

- KL3311: 2 bytes of input data
- KL3312 (KL3302): 4 bytes of input data
- KL3314: 8 bytes of input data

Parameterization via the fieldbus is not possible. If the control and status byte is to be used, the KS2000 configuration software is required.

Example for KL3312 (KL3302):

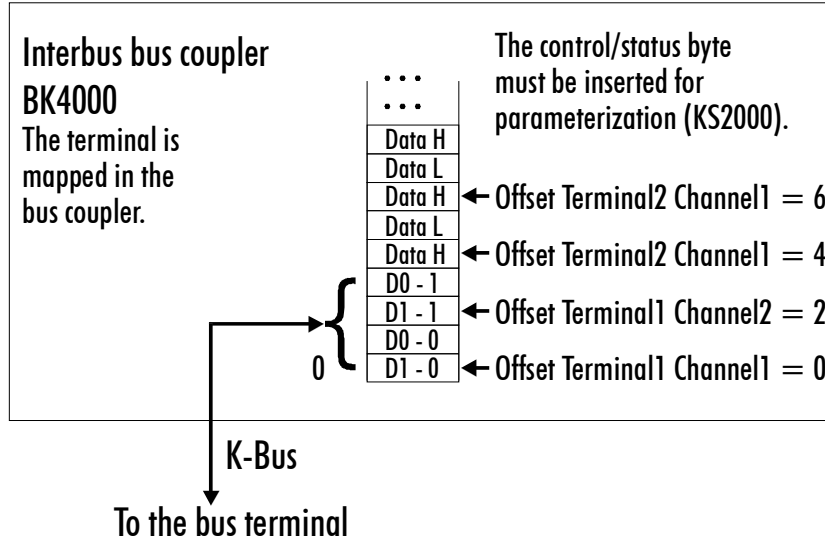

Other Bus Couplers and further information

Further information about the mapping configuration of Bus Couplers can be found in the Appendix of the respective Bus Coupler manual under *Master configuration*.



Note

Parameterization with KS2000

The Appendix contains an overview of possible mapping configurations depending on the parameters that can be set.

The parameterizations can be carried out independently of the fieldbus system with the KS2000 configuration software via the serial configuration interface in the Bus Coupler.

## Register Description

Different operating modes or functionalities may be set for the complex terminals. The *General Description of Registers* explains those register contents that are the same for all complex terminals.

The terminal-specific registers are explained in the following section.

Access to the internal terminal registers is described in the *Register Communication* section.

### General Description of Registers

Complex terminals that possess a processor are able to exchange data bi-directionally with the higher-level controller. These terminals are referred to below as intelligent Bus Terminals. These include analog inputs, analog outputs, serial interface terminals (RS485, RS232, TTY etc.), counter terminals, encoder interface, SSI interface, PWM terminal and all other parameterizable terminals.

The main features of the internal data structure are the same for all the intelligent terminals. This data area is organized as words and comprises 64 registers. The important data and parameters of the terminal can be read and set through this structure. It is also possible for functions to be called by means of corresponding parameters. Each logical channel in an intelligent terminal has such a structure (4-channel analog terminals therefore have 4 sets of registers).

This structure is divided into the following areas:  
(A detailed list of all registers can be found in the Appendix.)

Register	Application
0 to 7	Process variables
8 to 15	Type register
16 to 30	Manufacturer parameters
31 to 47	User parameters
48 to 63	Extended user area

#### Process variables

### **R0 to R7: Registers in the internal RAM of the terminal**

The process variables can be used in addition to the actual process image. Their function is specific to the terminal.

#### **R0 to R5: Terminal-specific registers**

The function of these registers depends on the respective terminal type (see terminal-specific register description).

#### **R6: Diagnostic register**

The diagnostic register can contain additional diagnostic information. Parity errors, for instance, that occur in serial interface terminals during data transmission are indicated here.

#### **R7: Command register**

High-Byte\_Write = function parameter

Low-Byte\_Write = function number

High-Byte\_Read = function result

Low-Byte\_Read = function number

#### Type register

### **R8 to R15: Registers in the internal ROM of the terminal**

The type and system parameters are hard programmed by the manufacturer, and the user can read them but cannot change them.

#### **R8: Terminal type**

The terminal type in register R8 is needed to identify the terminal.

#### **R9: Software version (X.y)**

The software version can be read as a string of ASCII characters.

#### **R10: Data length**

R10 contains the number of multiplexed shift registers and their length in bits.

The Bus Coupler sees this structure.

#### **R11: Signal channels**

Related to R10, this contains the number of channels that are logically present. Thus for example a shift register that is physically present can perfectly well consist of several signal channels.

#### **R12: Minimum data length**

The particular byte contains the minimum data length for a channel that is to be transferred. If the MSB is set, the control and status byte is not necessarily required for the terminal function and is not transferred to the control, if the Bus Coupler is configured accordingly.

**R13: Data type register**

Data type register	
<b>0x00</b>	Terminal with no valid data type
<b>0x01</b>	Byte array
<b>0x02</b>	Structure 1 byte n bytes
<b>0x03</b>	Word array
<b>0x04</b>	Structure 1 byte n words
<b>0x05</b>	Double word array
<b>0x06</b>	Structure 1 byte n double words
<b>0x07</b>	Structure 1 byte 1 double word
<b>0x08</b>	Structure 1 byte 1 double word
<b>0x11</b>	Byte array with variable logical channel length
<b>0x12</b>	Structure 1 byte n bytes with variable logical channel length (e.g. 60xx)
<b>0x13</b>	Word array with variable logical channel length
<b>0x14</b>	Structure 1 byte n words with variable logical channel length
<b>0x15</b>	Double word array with variable logical channel length
<b>0x16</b>	Structure 1 byte n double words with variable logical channel length

**R14: Reserved****R15: Alignment bits (RAM)**

The alignment bits are used to place the analog terminal in the Bus Coupler on a byte boundary.

Manufacturer parameters

**R16 to R30: Manufacturer parameter area (SEEPROM)**

The manufacturer parameters are specific for each type of terminal. They are programmed by the manufacturer, but can also be modified by the controller. The manufacturer parameters are stored in a serial EEPROM in the terminal, and are retained in the event of voltage drop-out. These registers can only be altered after a code-word has been set in R31.

User parameters

**R31 to R47: User parameter area (SEEPROM)**

The application parameters are specific for each type of terminal. They can be modified by the programmer. The application parameters are stored in a serial EEPROM in the terminal, and are retained in the event of voltage drop-out. The user area is write-protected by a code-word.



Note

**R31: Code-word register in RAM**

The code-word **0x1235** must be entered here so that parameters in the user area can be modified. If any other value is entered into this register, the write-protection is active. When write protection is not active, the code word is returned when the register is read. If the write protection is active, the register contains a zero value.

**R32: Feature register**

This register specifies the terminal's operating modes. Thus, for instance, a user-specific scaling can be activated for the analog I/Os.

**R33 to R47 Terminal-specific Registers**

The function of these registers depends on the respective terminal type (see terminal-specific register description).

Extended application region

**R47 to R63**

Extended registers with additional functions.

## Terminal-specific register description

### Process variables

**R0: Raw ADC value (X\_R)**

This register contains the unfiltered ADC value of the connected element according to (Eq. 0.1)  
(0x0000 corresponds to approx. -125mV, 0x8000 to approx. 0V, 0xFFFF to approx. 125 mV, i.e. gain and offset errors are present)

**R1 to R5: Reserved****R6: Diagnostic register**

High byte: reserved  
Low byte: status byte

### Manufacturer parameters

**R17: Hardware compensation - offset (B\_a)**

16 bit signed integer

This register is used for offset compensation of the terminal (Eq. 1.2).  
Register value approx. 0x0000

**R18: Hardware compensation - gain (A\_a)**

This register is used for gain compensation of the terminal (Eq. 1.2).  
Register value approx. 0x3D4X

**R19: Manufacturer scaling - offset (B\_h)**

16 bit signed integer [0x0000]

This register contains the offset of the manufacturer's equation of the straight line (1.6). The straight-line equation is activated via register R32.

**R20: Manufacturer scaling - gain (A\_h)**

16 bits signed integer  $\cdot 2^{-8}$  [0x00A0]

This register contains the scale factor of the manufacturer's equation of the straight line (1.6). The straight-line equation is activated via register R32.

**R21: Manufacturer gain compensation for reference voltage**

[approx. 0x01XX]

User parameters

**R32: Feature register**

[0x1006]

The feature register specifies the terminal's operating mode.

Feature bit no.		Description of the operating mode
Bit 0	1	User scaling (R33, R44) active [0]
Bit 1	1	Manufacturer scaling (R19, R20) active [1]
Bit 2	1	Watchdog timer active [1] In the delivery state, the watchdog timer is switched on.
Bit 3	1	Sign / amount representation [0] Sign / amount representation is active instead of two's-complement representation. (-1 = 0x8001)
Bit 4	1	Siemens output format [0] This bit is used for inserting status information on the lowest 3 bits (see below).
Bit 5	1	Activates filter constant in R37 [0]
Bit 6	1	Deactivates the measuring current for broken wire detection
Bit 7	-	reserved, do not change!
Bit 8	1	Reference temperature off [0]
Bit 9	-	reserved, do not change!
Bit 10	1	Checking of the lower measuring range limit not applicable. [0]
<b>Bit 15,14,13,12</b>	<b>Element</b>	<b>Valid measuring range</b>
0 0 0 0	Type: L	-25°C to 900°C
0 0 0 1	Type: K	-100°C to 1,370°C
0 0 1 0	Type: J	-100°C to 1,200°C
0 0 1 1	Type: E	-100°C to 1,000°C
0 1 0 0	Type: T	-100°C to 400°C
0 1 0 1	Type: N	-100°C to 1,300°C
0 1 1 0	Type: U	-25°C to 600°C
0 1 1 1	Type: B	600°C to 1,800°C
1 0 0 0	Type: R	0°C to 1,700°C
1 0 0 1	Type: S	0°C to 1,700°C
	<b>Output in <math>\mu</math>V resolution</b>	<b>Valid measuring range</b>
1 1 0 1	1 $\mu$ V*    1.6 $\mu$ V**	$\pm$ 30 mV
1 1 1 0	2 $\mu$ V*    3.2 $\mu$ V**	$\pm$ 60 mV
1 1 1 1	4 $\mu$ V*    6.4 $\mu$ V**	$\pm$ 120 mV ( $\pm$ 80 mV for KL3314)

\*) no scaling active

\*\*) only manufacturer scaling active

Examples

Bit 15 to 12: 1111, no scaling active:

The output format is as follows: 1 digit corresponds to 1/16 °C or to 4  $\mu$ V

Bit 15 to 12: 1111, manufacturer scaling activated via bit 1 of the feature register:

The output format is as follows: 1 digit corresponds to 1/10 °C or to 6.4  $\mu$ V

If the Siemens output format is selected, the lowest three bits are used to assess the status. The process data is represented in bits 3 to 15, with bit 15 representing the sign bit. Scaling of the measurement reading according to the Siemens standard has to be done via user scaling.

Measured value	Bit 15 ... 3	Bit 2 X	Bit 1 Error	Bit 0 Overflow
out of range		0	0	1
in range	Process data	0	0	0

### R33: User scaling - offset (B\_w)

16 bit signed integer

This register contains the offset of the user straight-line equation (1.7). The straight-line equation is activated via register R32.

### R34: User scaling - gain (A\_w)

16 bits signed integer\*  $2^{-8}$

This register contains the scale factor of the user straight-line equation (1.7). The straight-line equation is activated via register R32.

**R35 and R36: reserved**

### R37: Filter constant

[0x0000]



Note

This documentation applies to all terminals from software version 3x. The version number can be found within the serial number on the right-hand side face of the terminal: xxxx3xxx

Example: 5298**3A**2A ⇒ The firmware version is **3A**.

Filter constants:	First notch [Hz]	Conversion time [ms]
0x0000	25	250
0x50	100	65
0xA0	50	125
0x140	25	250
0x280	12.5	500

## Control and Status byte

Control byte for process data exchange

The control byte is transmitted from the controller to the terminal. The control byte is not used for KL331x and KL3302.

Status byte for process data exchange

The status byte is transmitted from the terminal to the controller. The status byte contains various status bits for the analog input channel:

status byte:

Bit 7 =  $0_{\text{bin}}$

Bit 6 =  $1_{\text{bin}}$ : ERROR - general error bit

Bit 5 to bit 2: reserved

Bit 1 =  $1_{\text{bin}}$ : Over range

Bit 0 =  $1_{\text{bin}}$ : Under range

Compensation

The terminals are compensated when delivered.

In order to compensate tolerances of the external components, gain and offset registers for compensating the thermocouple voltage are implemented for each channel, i.e. R17 (thermocouple voltage offset) and R18 (thermocouple voltage gain). For compensating the reference point temperature (temperature at the transition between the thermocouple and



the terminal contacts), a gain register (R21) is implemented, which is identical for both sets of registers.

Compensation can be carried out as follows:

First, the offset is carried out with 0V input voltage, reference temperature deactivated and linearization switched off. 0xF100 is entered in the feature register. This is followed by gain compensation with a maximum voltage of 125 mV (typical value: 70 mV). For this terminal setting with deactivated manufacturer scaling, the voltage is displayed with 4 µV per digit. Gain and offset compensation of the thermocouple voltage is carried out separately for each channel.

In the next step, the temperature of the reference point is compensated. To this end, a thermocouple has to be selected via the feature register, and reference point temperature compensation must be active (R32 0x1006 type K). With short-circuited inputs (0 V), the temperature of the terminal contacts is determined, and the temperature output by the terminal (measured via an internal temperature sensor) is set accordingly (via R21).

The reference point temperature only has to be calibrated once for each terminal, i.e. R21 is identical for both channels.

## Register communication

Register access via process data exchange  
Bit 7=1<sub>bin</sub>: Register mode

If bit 7 of the control byte is set, then the first two bytes of the user data are not used for exchanging process data, but are written into or read from the terminal's register set.

Bit 6=0<sub>bin</sub>: read  
Bit 6=1<sub>bin</sub>: write

Bit 6 of the control byte specifies whether a register should be read or written. If bit 6 is not set, then a register is read out without modifying it. The value can then be taken from the input process image.

If bit 6 is set, then the user data is written into a register. As soon as the status byte has supplied an acknowledgement in the input process image, the procedure is completed (see example).

Bit 0 to 5: Address

The address of the register that is to be addressed is entered into bits 0 to 5 of the control byte.

Control byte in register mode

MSB

REG=1	W/R	A5	A4	A3	A2	A1	A0
-------	-----	----	----	----	----	----	----

REG = 0<sub>bin</sub>: Process data exchange

REG = 1<sub>bin</sub>: Access to register structure

W/R = 0<sub>bin</sub>: Read register

W/R = 1<sub>bin</sub>: Write register

A5...A0 = register address

Address bits A5 to A0 can be used to address a total of 64 registers.

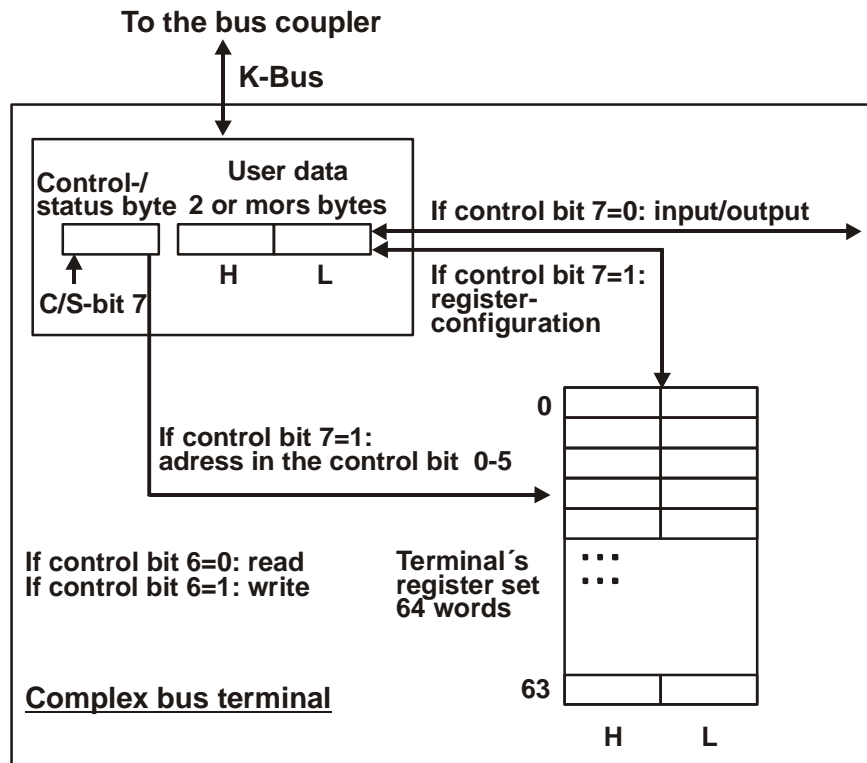

The control or status byte occupies the lowest address of a logical channel. The corresponding register values are located in the following 2 data bytes. (The BK2000 is an exception: here, an unused (reserved) data byte is automatically inserted after the control or status byte, and the register value is therefore placed on a word boundary).

Example 1

Reading of register 8 in the BK2000 with a KL3312 and the end terminal:  
If the following bytes are transferred from the control to the terminal,

Byte	Byte 3	Byte 2	Byte 1	Byte 0
Name	DataOUT 1	DataOUT 0	Not used	Control byte
Value	0xXX	0xXX	0xXX	0x88

the terminal returns the following type identifier (0x0CF0 corresponds to unsigned integer 3312).

Byte	Byte 3	Byte 2	Byte 1	Byte 0
Name	DataIN 1	DataIN 0	Not used	Status byte
Value	0x0C	0xF0	0x00	0x88

Example 2

Writing of register 31 in the BK2000 with an intelligent terminal and the end terminal:  
If the following bytes (code word) are transferred from the control to the terminal,

Byte	Byte 3	Byte 2	Byte 1	Byte 0
Name	DataOUT 1	DataOUT 0	Not used	Control byte
Value	0x12	0x35	0xXX	0xDF

the code word is set, and the terminal returns the register address with bit 7 for register access as acknowledgement.

Byte	Byte 3	Byte 2	Byte 1	Byte 0
Name	DataIN 1	DataIN 0	Not used	Status byte
Value	0x00	0x00	0x00	0x9F

# Appendix

## Mapping

As already described in the *Terminal Configuration* section, each Bus Terminal is mapped in the Bus Coupler. In the delivery state, this mapping occurs with the default settings of the Bus Coupler for this terminal. The default setting can be changed with the KS2000 configuration software or with a master configuration software (e.g. TwinCAT System Manager or ComProfibus).

If the terminals are fully evaluated, they occupy memory space in the input and output process image.

The following tables provide information about the terminal mapping, depending on the conditions set in the Bus Coupler.

### KL3311

Default mapping for:  
CANopen, CANCEL,  
DeviceNet, ControlNet,  
Modbus, RS232, RS485

Conditions	Word offset	High byte	Low byte
Complete evaluation: no	0	Ch0 D1	Ch0 D0
Motorola format: no	1	-	-
Word alignment: any	2	-	-
	3	-	-

Default mapping for:  
PROFIBUS, Interbus

Conditions	Word offset	High byte	Low byte
Complete evaluation: no	0	Ch0 D0	Ch0 D1
Motorola format: yes	1	-	-
Word alignment: any	2	-	-
	3	-	-

Conditions	Word offset	High byte	Low byte
Complete evaluation: yes	0	Ch0 D0	Ch0 CB/SB
Motorola format: no	1	-	Ch0 D1
Word alignment: no	2	-	-
	3	-	-

Conditions	Word offset	High byte	Low byte
Complete evaluation: yes	0	Ch0 D1	Ch0 CB/SB
Motorola format: yes	1	-	Ch0 D0
Word alignment: no	2	-	-
	3	-	-

Default mapping for:  
Lightbus, Ethernet,  
EtherCAT and  
Bus Terminal Controller  
(BCxxxx, BXxxxx)

Conditions	Word offset	High byte	Low byte
Complete evaluation: yes	0	res.	Ch0 CB/SB
Motorola format: no	1	Ch0 D1	Ch0 D0
Word alignment: yes	2	-	-
	3	-	-

Conditions	Word offset	High byte	Low byte
Complete evaluation: yes	0	res.	Ch0 CB/SB
Motorola format: yes	1	Ch0 D0	Ch0 D1
Word alignment: yes	2	-	-
	3	-	-

Legend

See KL3312 mapping.

**KL3312 (KL3302)**

Default mapping for:  
CANopen, CANCAL,  
DeviceNet, ControlNet,  
Modbus, RS232, RS485

Conditions	Word offset	High byte	Low byte
Complete evaluation: no	0	Ch0 D1	Ch0 D0
Motorola format: no	1	Ch1 D1	Ch1 D0
Word alignment: any	2	-	-
	3	-	-

Default mapping for:  
PROFIBUS, Interbus

Conditions	Word offset	High byte	Low byte
Complete evaluation: no	0	Ch0 D0	Ch0 D1
Motorola format: yes	1	Ch1 D0	Ch1 D1
Word alignment: any	2	-	-
	3	-	-

Conditions	Word offset	High byte	Low byte
Complete evaluation: yes	0	Ch0 D0	Ch0 CB/SB
Motorola format: no	1	Ch1 CB/SB	Ch0 D1
Word alignment: no	2	Ch1 D1	Ch1 D0
	3	-	-

Conditions	Word offset	High byte	Low byte
Complete evaluation: yes	0	Ch0 D1	Ch0 CB/SB
Motorola format: yes	1	Ch1 CB/SB	Ch0 D0
Word alignment: no	2	Ch1 D0	Ch1 D1
	3	-	-

Default mapping for:  
Lightbus, Ethernet,  
EtherCAT and  
Bus Terminal Controller  
(BCxxxx, BXxxxx)

Conditions	Word offset	High byte	Low byte
Complete evaluation: yes	0	res.	Ch0 CB/SB
Motorola format: no	1	Ch0 D1	Ch0 D0
Word alignment: yes	2	res.	Ch1 CB/SB
	3	Ch1 D1	Ch1 D0

Conditions	Word offset	High byte	Low byte
Complete evaluation: yes	0	res.	Ch0 CB/SB
Motorola format: yes	1	Ch0 D0	Ch0 D1
Word alignment: yes	2	res.	Ch1 CB/SB
	3	Ch1 D0	Ch1 D1

**Legend**

**Complete evaluation:**

The terminal is mapped with control and status byte.

**Motorola format:**

Motorola or Intel format can be set.

**Word alignment:**

The terminal is at word limit in the Bus Coupler.

Ch n SB: status byte for channel n (appears in the input process image).

Ch n CB: control byte for channel n (appears in the output process image).

Ch n D0: channel n, data byte 0 (byte with the lowest value)

Ch n D1: channel n, data byte 1 (byte with the highest value)

"-": This byte is not used or occupied by the terminal.

res.: reserved:

This byte occupies process data memory, although it is not used.

### KL3314

Default mapping for:  
CANopen, CANCAL,  
DeviceNet, ControlNet,  
Modbus, RS232, RS485

Conditions	Word offset	High byte	Low byte
Complete evaluation: no	0	Ch0 D1	Ch0 D0
Motorola format: no	1	Ch1 D1	Ch1 D0
Word alignment: any	2	Ch2 D1	Ch2 D0
	3	Ch3 D1	Ch3 D0

Default mapping for:  
PROFIBUS, Interbus

Conditions	Word offset	High byte	Low byte
Complete evaluation: no	0	Ch0 D0	Ch0 D1
Motorola format: yes	1	Ch1 D0	Ch1 D1
Word alignment: any	2	Ch2 D0	Ch2 D1
	3	Ch3 D0	Ch3 D1

Conditions	Word offset	High byte	Low byte
Complete evaluation: yes	0	Ch0 D0	Ch0 CB/SB
Motorola format: no	1	Ch1 CB/SB	Ch0 D1
Word alignment: no	2	Ch1 D1	Ch1 D0
	3	Ch2 D0	Ch2 CB/SB
	4	Ch3 CB/SB	Ch2 D1
	5	Ch3 D1	Ch3 D0

Conditions	Word offset	High byte	Low byte
Complete evaluation: yes	0	Ch0 D1	Ch0 CB/SB
Motorola format: yes	1	Ch1 CB/SB	Ch0 D0
Word alignment: no	2	Ch1 D0	Ch1 D1
	3	Ch2 D1	Ch2 CB/SB
	4	Ch3 CB/SB	Ch2 D0
	5	Ch3 D0	Ch3 D1

Default mapping for:  
Lightbus, Ethernet,  
EtherCAT and  
Bus Terminal Controller  
(BCxxxx, BXxxxx)

Conditions	Word offset	High byte	Low byte
Complete evaluation: yes	0	res.	Ch0 CB/SB
Motorola format: no	1	Ch0 D1	Ch0 D0
Word alignment: yes	2	res.	Ch1 CB/SB
	3	Ch1 D1	Ch1 D0
	4	res.	Ch2 CB/SB
	5	Ch2 D1	Ch2 D0
	6	res.	Ch3 CB/SB
	7	Ch3 D1	Ch3 D0

Conditions	Word offset	High byte	Low byte
Complete evaluation: yes	0	res.	Ch0 CB/SB
Motorola format: yes	1	Ch0 D0	Ch0 D1
Word alignment: yes	2	res.	Ch1 CB/SB
	3	Ch1 D0	Ch1 D1
	4	res.	Ch2 CB/SB
	5	Ch2 D0	Ch2 D1
	6	res.	Ch3 CB/SB
	7	Ch3 D0	Ch3 D1

Legend

See KL3312 mapping.

## Register Table

These registers exist once for each channel.

Address	Denomination	Default value	R/W	Storage medium
R0	Raw ADC value	variable	R	RAM
R1	reserved	0x0000	R	
...	...	...	...	
R5	reserved	0x0000	R	
R6	Diagnostic register	variable	R	RAM
R7	Command register not used	0x0000	R	
R8	Terminal type	3302/3312	R	ROM
R9	Software version number	0x????	R	ROM
R10	Multiplex shift register	0x0218/0130	R	ROM
R11	Signal channels	0x0218	R	ROM
R12	Minimum data length	0x0098	R	ROM
R13	Data structure	0x0000	R	ROM
R14	reserved	0x0000	R	
R15	Alignment register	variable	R/W	RAM
R16	Hardware version number	0x????	R/W	SEEROM
R17	Hardware compensation: Offset	specific	R/W	SEEROM
R18	Hardware compensation: Gain	specific	R/W	SEEROM
R19	Manufacturer scaling: Offset	0x0000	R/W	SEEROM
R20	Manufacturer scaling: Gain	0x00A0	R/W	SEEROM
R21	Hardware compensation: Reference temperature	specific	R/W	SEEROM
R22	reserved	0x0000	R/W	SEEROM
...	...	...	...	...
R30	reserved	0x0000	R/W	SEEROM
R31	Code word register	variable	R/W	RAM
R32	Feature register	0x1006	R/W	SEEROM
R33	User scaling: Offset	0x0000	R/W	SEEROM
R34	User scaling: Gain	0x0100	R/W	SEEROM
R35	reserved	0x0000	R/W	SEEROM
R36	reserved	0x0000	R/W	SEEROM
R37	reserved	0x0138	R/W	SEEROM
...	...	...	...	...
R63	reserved	0x0000	R/W	SEEROM

## Support and Service

Beckhoff and their partners around the world offer comprehensive service and support, making available fast and competent assistance with all questions related to Beckhoff products and system solutions.

### Beckhoff's branch offices and representatives

Please contact your Beckhoff branch office or representative for local support and service on Beckhoff products!

The addresses of Beckhoff's branch offices and representatives round the world can be found on her internet pages: <http://www.beckhoff.com>

You will also find further documentation for Beckhoff components there.

### Beckhoff company headquarters

Beckhoff Automation GmbH  
Eiserstr. 5  
D-33415 Verl  
Germany

Phone: +49(0)5246/963-0  
Fax: +49(0)5246/963-198  
e-mail: [info@beckhoff.com](mailto:info@beckhoff.com)  
web: <http://www.beckhoff.com>

### Beckhoff Support

Support offers you comprehensive technical assistance, helping you not only with the application of individual Beckhoff products, but also with other, wide-ranging services:

- world-wide support
- design, programming and commissioning of complex automation systems
- and extensive training program for Beckhoff system components

Hotline: +49(0)5246/963-157  
Fax: +49(0)5246/963-9157  
e-mail: [support@beckhoff.com](mailto:support@beckhoff.com)

### Beckhoff Service

The Beckhoff Service Centre supports you in all matters of after-sales service:

- on-site service
- repair service
- spare parts service
- hotline service

Hotline: +49(0)5246/963-460  
Fax: +49(0)5246/963-479  
e-mail: [service@beckhoff.com](mailto:service@beckhoff.com)