

InterBus Coupler BK4000

valid for all BK4xxx bus coupler

Technical Documentation

**Version 1.3
2006-10-24**

BECKHOFF

Contents

1. Foreword	3
Notes on the documentation	3
Liability Conditions	3
Delivery conditions	3
Copyright	3
Safety Instructions	4
State at Delivery	4
Description of safety symbols	4
2. Basic information	5
The Beckhoff bus terminal system	5
The interfaces	7
Power supply	7
Power supply to the power contacts	7
Power contacts	7
Field bus connection	7
Configuration interface	8
K-bus contacts	8
Supply isolation	8
The operating modes of the bus coupler	9
Mechanical construction	10
Electrical data	12
The peripheral data in the process image	13
Starting operation and diagnostics	16
ID code and ID length	17
Run times and reaction times	19
3. InterBus coupler BK4000 in InterBus S	21
Presentation of the system	21
The medium: connector and cable	21
Configuration of masters	23
4. Annex	24
Example: combination of a process image in the bus coupler	24
Representation of analog signals in the process image	26
5. Support and Service	28
Beckhoff's branch offices and representatives	28
Beckhoff Headquarters	28
Beckhoff Support	28
Beckhoff Service	28

Foreword

Notes on the documentation

This description is only intended for the use of trained specialists in control and automation engineering who are familiar with the applicable national standards. It is essential that the following notes and explanations are followed when installing and commissioning these components.

Liability Conditions

The responsible staff must ensure that the application or use of the products described satisfy all the requirements for safety, including all the relevant laws, regulations, guidelines and standards.

The documentation has been prepared with care. The products described are, however, constantly under development. For that reason the documentation is not in every case checked for consistency with performance data, standards or other characteristics. None of the statements of this manual represents a guarantee (Garantie) in the meaning of § 443 BGB of the German Civil Code or a statement about the contractually expected fitness for a particular purpose in the meaning of § 434 par. 1 sentence 1 BGB. In the event that it contains technical or editorial errors, we retain the right to make alterations at any time and without warning. No claims for the modification of products that have already been supplied may be made on the basis of the data, diagrams and descriptions in this documentation.

Delivery conditions

In addition, the general delivery conditions of the company Beckhoff Automation GmbH apply.

Copyright

© This documentation is copyrighted. Any reproduction or third party use of this publication, whether in whole or in part, without the written permission of Beckhoff Automation GmbH, is forbidden.

Safety Instructions

State at Delivery

All the components are supplied in particular hardware and software configurations appropriate for the application. Modifications to hardware or software configurations other than those described in the documentation are not permitted, and nullify the liability of Beckhoff Automation GmbH.

Description of safety symbols

The following safety symbols are used in this documentation. They are intended to alert the reader to the associated safety instructions..



Danger

This symbol is intended to highlight risks for the life or health of personnel.



Attention

This symbol is intended to highlight risks for equipment, materials or the environment.



Note

This symbol indicates information that contributes to better understanding.

Basic information

The Beckhoff bus terminal system

Up to 64 bus terminals

*each with 2 I/O channels
for any form of signal*

*Decentralized wiring of
the I/O level*

IPC as control unit

*Bus couplers for all current
bus systems*

Standard C rail assembly

Modularity

Display of channel status

The K-bus

End terminal

The bus terminal system is the universal connecting link between a fieldbus system and the sensor/actor level. A unit consists of a bus coupler, which is the interface to the fieldbus, and up to 64 electronic terminals, of which the last is an end terminal. Terminals, each with two I/O channels, are available for any form of technical signal and can be combined as desired. The various types of terminal are all constructed in the same way, so that the planning costs are kept extremely low. The height and depth of the construction are calculated for compact terminal cabinets.

Fieldbus technology makes it possible to use compact control architectures. The I/O level does not need to be taken right up to the control unit. Sensors and actors can be connected decentrally with minimal lengths of cable. You can position the control unit at any convenient location in the installation. Using an industrial PC as control unit makes it possible to implement the operating and monitoring element as part of the control hardware, so the control unit can be located on an operating desk, control point or similar. The bus terminals constitute the decentralized input/output level of the control unit in the switch cabinet and its subordinate terminal cabinets. As well as the sensor/actor level, the power unit of the equipment is also controlled via the bus system. The bus terminal replaces a conventional terminal as the cabling level in the switch cabinet; the switch cabinet can be made smaller.

The Beckhoff bus terminal system combines the advantages of a bus system with the functionality of compact terminals. Bus terminals can be used on all current bus systems and serve to reduce the diversity of parts in the control unit, while behaving like the conventional standard units for the relevant bus system and supporting the entire range of functionality of the bus system.

The simple and compact assembly on a standard C rail, and the direct cabling of actors and sensors without cross connections between the terminals, serve to standardize the installation, as does the uniformly designed labeling.

The small size and great flexibility of the bus terminal system mean that you can use it anywhere that you could use a terminal and use any type of connection – analog, digital, serial or direct sensors.

The modular construction of the terminal row, using bus terminals with various functions, limits the number of unused channels to at most one per function. Two channels to a terminal is the optimum solution for the number of unused channels and the cost per channel. The possibility of using power input terminals to provide separate power supplies also helps to minimize the number of unused channels.

The integrated light-emitting diodes close to the sensor/actor indicate the status of each channel.

The K-bus is the path taken by data within the terminal row. The bus coupler carries the K-bus through all the terminals by means of six contacts on the side walls of the terminals, and the end terminal terminates the K-bus. The user does not need to know anything about the function of the K-bus or the internal operation of terminals and bus couplers. There are numerous software tools available which provide for convenient planning, configuration and operation.

Power input terminals for separately powered groups

Three power contacts pass the operating power to the following terminals. You can use power input terminals to subdivide the terminal row as desired into groups, each with a separate power supply. These power input terminals are not taken into account for addressing the terminals, you can insert them at any position along the terminal row. You can install up to 64 terminals on a terminal row, including power input terminals and the end terminal.

The principle of the bus terminal

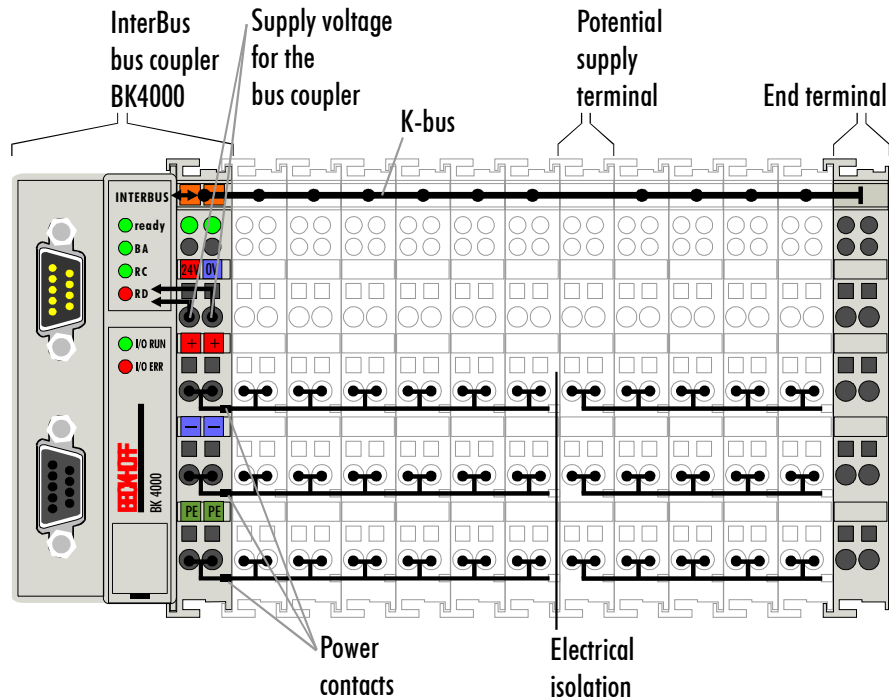

Bus couplers for various fieldbus systems

You can use a variety of bus couplers to attach the electronic terminal row quickly and easily to the various fieldbus systems, and you can also subsequently convert to a different fieldbus system. The bus coupler deals with all the necessary monitoring and control tasks for operating the attached bus terminals, indeed all the operation and configuration of the bus terminals is carried out via the bus coupler. The fieldbus, K-bus and I/O level are electrically isolated.

If the exchange of data across the fieldbus is temporarily interrupted, logic states are preserved, digital outputs are cleared and analog outputs revert to a reset value which can be individually configured for each output when the equipment is set up.

The interfaces

There are six ways of making a connection to a bus coupler. These interfaces are designed as plug connections and spring terminals.

The InterBus-coupler
BK4000

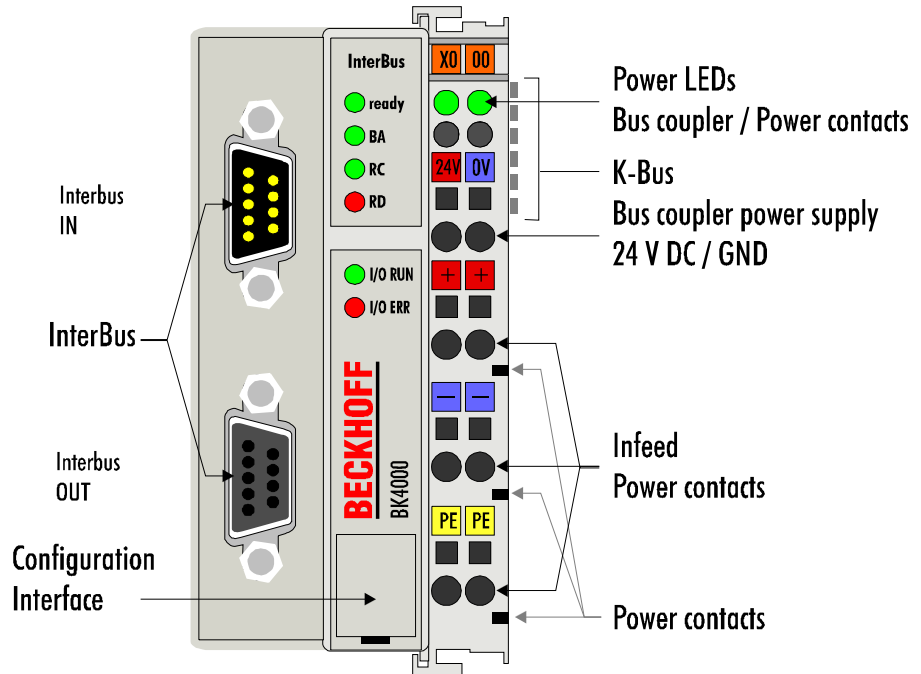

24 V DC on the topmost terminals "24 V" and "0 V"

Power supply

The bus couplers need an operating power of 24 V DC which is connected via the topmost spring terminals, labeled "24 V" and "0 V". This power supply serves not only the electronic components of the bus coupler but (via the K-bus) also the bus terminals. The power supply of the bus coupler circuitry and that of the K-bus are electrically isolated from the voltage of the field level.

Lower 3 terminal pairs for power input

Power supply to the power contacts

The six lower connections with spring terminals can be used to supply power to the peripherals. The spring terminals are connected in pairs to the power contacts. The power supply to the power contacts has no connection to the power supply of the bus couplers. The power input is designed to permit voltages up to 24 V. The pair-wise arrangement and the electrical connection between the feed terminal contacts makes it possible to loop through the wires connecting to different terminal points. The load on the power contact may not continuously exceed 10 A. The current capacity between two spring terminals is the same as the capacity of the connecting wires.

maximum 24 V

maximum 10 A

Spring contacts at the side

Power contacts

On the right-hand side face of the bus coupler are three spring contacts which are the power connections. The spring contacts are recessed in slots to prevent them from being touched. When a bus terminal is connected, the blade contacts on the left-hand side of the bus terminal are connected to the spring contacts. The slot and key guides at the top and bottom of the bus couplers and bus terminals ensure reliable location of the power contacts.

9 pin Sub-D female connector

9 pin Sub-D male connector

Field bus connection

There is a recessed front surface on the left-hand side. The typical Interbus connectors can be inserted here. You will find a detailed description of the field bus interfaces in the Chapter entitled „The medium: connector and cable“.

Configuration interface

Serial interface under the front flap

On the lower part of the front face you will find the standbus couplers which are fitted with an RS232 interface. The miniature plug can be attached to a PC by means of a connection cable and the configuration software KS2000. This interface enables you to configure the analog channels. You can also access the functionality of the configuration interface via the fieldbus by means of the PLC-Interface. The PLC interface consists of two additional bytes that are also inserted in the process data.

K-bus contacts

6 contacts at the side

The connections between the bus coupler and the bus terminals are effected by gold contacts at the right-hand side of the bus coupler. When the bus terminals are plugged together, these gold contacts automatically complete the connection to the bus terminals. The K-bus is responsible for the power supply to the electronic components of the K-bus in the bus terminals, and for the exchange of data between the bus coupler and the bus terminals. Part of the data exchange takes place via a ring structure within the K-bus. Disengaging the K-bus, for example by pulling on one the bus terminals, will break this circuit so that data can no longer be exchanged. However, there are mechanisms in place which enable the bus coupler to locate the interruption and report it.

Supply isolation

*3 supply groups:
fieldbus
K-bus
peripheral level*

The bus couplers operate with three independent supplies. The input power supplies the electrically isolated K-bus circuitry in the bus coupler and the K-bus itself. The power supply is also used to generate the operating power for the fieldbus.

Note: All the bus terminals are electrically isolated from the K-bus, so that the K-bus is completely electrically isolated.

Setting up the power levels in the bus terminal system

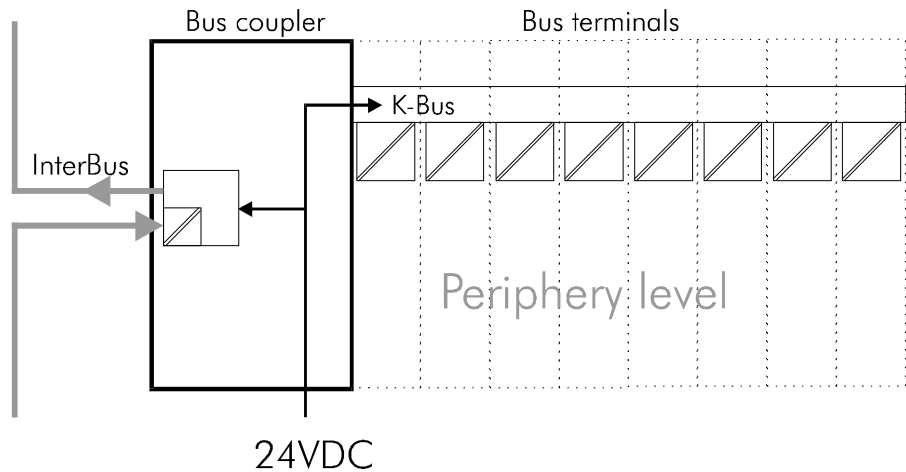

The operating modes of the bus coupler

When it is first switched on the bus coupler carries out a self-test to check the functions of its components and the communications of the K-bus, and while this is going on the red I/O LED will flash. When the self-test has been completed successfully, the bus coupler will begin to test the attached bus terminals (the "bus terminal test") and read in the configuration from which it constructs an internal structure list, which is not accessible from outside. If an error occurs the bus coupler will enter the operating mode "STOP". If the start-up sequence is completed without errors the bus coupler will enter the mode "fieldbus start". The I/O RUN LED is lightening.

Start-up behavior of the bus coupler

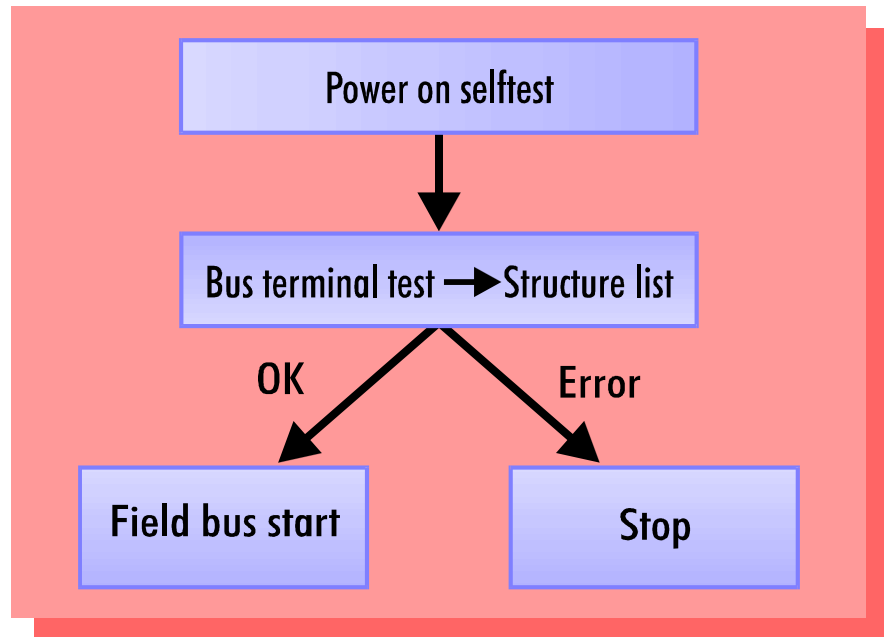

After troubleshooting, the bus coupler can only be brought to the normal operating state by switching on again or by means of a field bus reset (triggered automatically by the master).

Mechanical construction

The Beckhoff bus terminal system is distinguished by its small volume and its high modularity. For project planning, one bus coupler and a number of bus terminals must be planned. The bus coupler's installation dimensions are independent of the field bus system. The total height of the housings may be exceeded if larger connectors are used, for example in the case of some high bus connectors for the InterBus.

Dimensions of a bus coupler

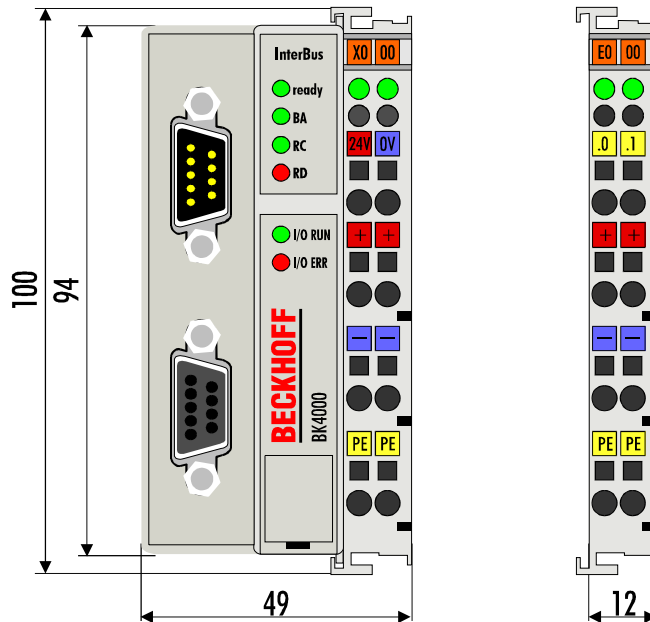

The overall width of the construction is the width of the bus coupler, including the bus end terminal, plus the width of the installed bus terminals. The bus terminals are 12 mm or 24 mm wide, depending on their function. Depending on the gauge of cables used the overall height of 68 mm may be overstepped by about 5 mm to 10 mm by the cables at the front.

Assembly and connections

It takes only a slight pressure to latch the bus coupler and the various bus terminals onto a supporting 35 mm C rail and a locking mechanism then prevents the individual housings from being removed. You can remove them without effort if you first release the latching mechanism by pulling the orange tab. You should carry out work on the bus terminals and the bus coupler only while they are switched off: if you plug or unplug components while the power is on you may briefly provoke some undefined state (and, for instance, reset the bus coupler).

You can attach up to 64 bus terminals in series on the right-hand side of the bus coupler. When you assemble the components, make sure that you mount the housings so that each slot comes together with the corresponding key. You cannot make any functional connections merely by pushing the housings together along the supporting track. When they are correctly mounted there should be no appreciable gap between the adjacent housings.

The right-hand side of a bus coupler is mechanically similar to a bus terminal. There are eight connections on the top which can be used to connect to thick-wire or thin-wire lines. The connection terminals are spring loaded. You open a spring terminal by applying a slight pressure with a screwdriver or other pointed tool in the opening above the terminal and you can then insert the wire into the terminal without any obstruction. When you release the pressure the terminal will automatically close and hold the wire secure-

ly and permanently.

The connection between bus couplers and bus terminals is automatically effected by latching the components together. The K-bus is responsible for passing data and power to the electronic components of the bus terminals. In the case of digital bus terminals, the field logic receives power via the power contacts. Latching the components together has the effect that the series of power contacts constitutes a continuous power track. Please refer to the circuit diagrams of the bus terminals: some bus terminals do not loop these power contacts through, or not completely (e.g. analog bus terminals or 4-channel digital bus terminals). Each power input terminal interrupts the series of power contacts and constitutes the beginning of a new track. The bus coupler can also be used to supply power to the power contacts.

Insulation test

The power contact labeled "PE" can be used as protective earth or ground. This contact stands proud for safety reasons and can carry short-circuit currents of up to 125A. Note that in the interests of electromagnetic compatibility the PE contacts are capacitively connected to the supporting track. This may lead to spurious results and even damage to the terminal when you test the insulation (e.g. insulation test for breakdown using a 230V mains supply to the PE line). You should therefore disconnect the PE line on the bus coupler while you carry out insulation tests. You can disconnect other power supply points for the duration of the test by drawing the power supply terminals out from the remaining row of terminals by at least 10mm. If you do this, there will be no need to disconnect the PE connections.

PE power contacts

The protective earth power contact ("PE") may not be used for any other connections.

Electrical data

The InterBus couplers differ by virtue of their capacity levels. The electrical data specific to the field bus is listed in this chapter. The following data differs depending on whether a standard or an economy variant is meant (BK4000, BK4500 and BK4010). Contrary to the standard variant, the economy variant limits the number of I/O points. Thus, there is no possibility of connecting inputs and outputs other than digital inputs and outputs.

Technical data	InterBus-coupler BK4000/BK4500	Economy -coupler BK4010
Power supply	24 V, - 15% + 20%	
Input current	105 mA typ. (30 digital inputs- / 20 outputs) 900 mA max.	85 mA typ. 300 mA max.
K-Bus output current	1750 mA max.	500 mA max.
Potential isolation	500 Vrms (K-bus / power supply to periphery)	
Number of bus terminals	64 including potential feed terminals and end terminal	
Digital peripheral signals	256 inputs and outputs	256 inputs and outputs
Analog peripheral signals	32 inputs and outputs#1	--
Peripheral bytes	64 input bytes and 64 output bytes	32 input and 32 output bytes
Configuration interface	available for KS2000	
Baud rates	500 KBaud in conformity with the standard	
Power contact voltage	24V DC / AC	
Power contact current load	10 A	
Dielectric strength	500 Vrms (Power contact / InterBus signal voltage), incoming interface	
Typical weight	170g	
Operating temperature	0°C ... +55°C	
Storage temperature	-20°C ... +85°C	
Relative humidity	95%, no condensation	
Vibration / shock strength	in conformity with IEC 68-2-6 / IEC 68-2-27	
EMC strength, Burst / ESD	in conformity with EN 61000-4-4/ EN 61000-4, limit EN 50082-2-4	
Installation position	any	
Type of protection	IP20	

Current consumption on the K-Bus

For operation of the K-Bus electronics, the bus terminals require power from the K-Bus which the bus coupler supplies. Refer to the catalog or the corresponding data sheets of the bus terminals for details of the current consumption of the K-Bus. At the same time, pay attention to the maximum output current of the bus coupler that is available for powering the bus terminals. By means of a special power supply terminal, an infeed into the K-Bus is possible at any point. Please consult Beckhoff's technical support for details of how to use a power supply terminal.

The peripheral data in the process image

After power on, the bus coupler determines the configuration of the inserted input/output terminals. The bus coupler automatically assigns the affiliations between the physical slots of the input/output channels and the addresses of the process image.

The bus coupler generates an internal allocation list in which the input/output channels have a specific position in the process image. Here, a distinction is made according to inputs and outputs and according to bit-oriented (digital) and byte-oriented (analog or complex) signal processing.

Two groups with only inputs or outputs each are formed. In one group, the byte-oriented channels are at the least significant address in ascending order. This block is followed by the bit-oriented channels.

Digital signals (bit-oriented)

Digital signals are bit-oriented. This means that one bit of the process image is assigned to each digital channel. The bus coupler sets up a block of memory containing the current input bits and arranges to immediately write out the bits from a second block of memory which belongs to the output channels.

The precise assignment of the input and output channels to the process image of the control unit is explained in detail in the Appendix by means of an example.

Analog signals (byte-oriented)

Processing of the analog signals is fundamentally byte-oriented. The analog input and output values are stored in the memory in a two-byte notation. The values are represented as "SIGNED INTEGER". The numeric value "0" stands for the input/output value "0V", "0mA" or "4mA". In the default setting, the maximum value of the input/output value is represented by "7FFF" hex. The intermediate values are accordingly proportional with respect to one another. The area with a resolution of 15 bits is not realized with every input or output stage. In the event of an actual resolution of 12 bits, the last three bits are of no effect for outputs and, for inputs, they are read as "0". Each channel also has a control and status byte. The control and status byte is the most significant byte in the most significant word. An analog channel is represented with four bytes in the process image, three bytes of which are used. (In the BK3000 and BK4000, only two bytes are occupied for each analog channel in the process image of the corresponding bus system. The control and status bytes of the bus terminals can also be inserted by reconfiguration in the bus coupler and in the bus terminals.)

Special signals and interface

The BK4000 supports bus terminals with further interfaces such as RS232, RS485, incremental encoders or others. These signals can be controlled just like the above-mentioned analog signals. To some extent, a bit width of 16 does not suffice for the special signals. The bus coupler is capable of supporting any byte width. The effective byte length of the bus terminals can be preset with the KS2000 software.

Default assignment of inputs and outputs to the process image

When the bus coupler is first switched on it determines the number of attached bus terminals and sets up a list of assignments. This list distinguishes between analog channels and digital channels and between input and output; which are grouped separately. The assignments begin immediately to the left of the bus coupler. The software in the bus coupler creates the assignment list by collecting the entries for the individual channels one at a time, counting from left to right.

These assignments distinguish four groups:

	Function type of the channel	Assignment level
1.	Analog outputs	byte-wise assignment
2.	Digital outputs	bit-wise assignment
3.	Analog inputs	byte-wise assignment
4.	Digital inputs	bit-wise assignment

Analog inputs/outputs are representative of other complex multi-byte signal bus terminals. The byte length of these terminals can be adjusted with the KS2000 software.

Overview of the breakdown of the process image in the bus coupler:
 The „x“ variable represents the number of analog channels. By default, one channel has one word with 16 bits. The „y“ variable represents the number of words with digital data. It is calculated on the basis of:
 $y = (\text{integral result (number of digital channels / 16)} + 1)$

Output data in the bus coupler

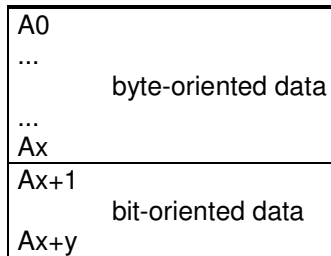

Input data in the bus coupler

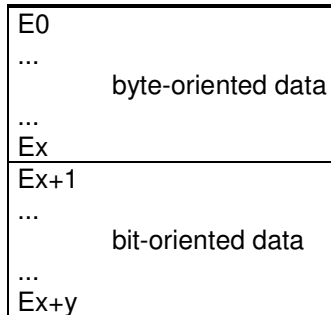

The path from the I/Os to the process image in the InterBus

The bus coupler automatically assigns the I/Os of the terminals to the process image in the Interbus protocol. The figure symbolically shows an allocation list. In special applications, the allocation list can be modified to suit requirements by using the KS2000 configuration software.

The allocation list in the master has the same effect. Byte-by-byte allocation is possible with the Phoenix Contact Firmware version 4.0 and higher. The master software CMD version 4.0 and higher is needed for this purpose. Setting via FB in the PLC is possible, but is not advisable owing to its great complexity.

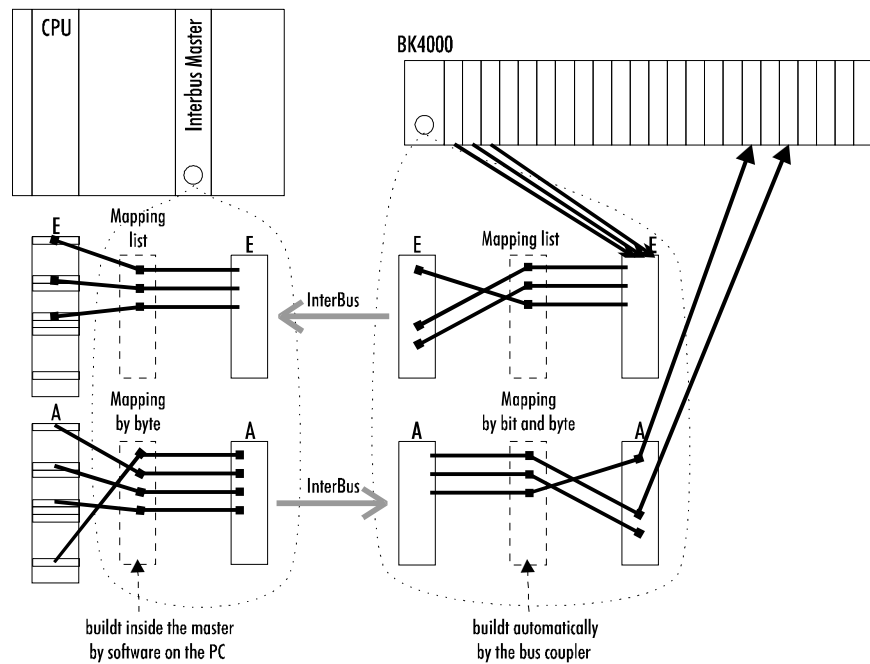

Data consistency

Data is described as being consistent if its contents fit together. The following contents belong together:

1. the high and low bytes of an analog value (word consistency).
2. The control/status byte and the affiliated parameter word for access to the registers (e.g. 3-byte input/output for an analog channel).

In the interplay of the peripherals and the controller, data consistency is fundamentally initially only ensured for one byte (for most IBS masters, consistency exists for one word). That is to say, the bits of one byte are read in together or are output together. The InterBus transports all data of all inputs and outputs in one cycle. After an error-free transfer, the data is available for the controller. In practical terms, the master realises the „making available“ by switching over from the old data block to the one that is now the current one. If the controller accesses the data area at the time of changeover, it reads a portion of the old data and a portion of the new data. As the controllers only access the memory word by word or even only byte by byte, the corresponding data consistency is produced. For processing of digital signals, byte consistency is sufficient. In cases when values with a length of more than 8 bits are transferred, e.g. in the case of analog values, the consistency must be extended. Attention must be paid to the correct method of acceptance by the controller of the consistent data from the bus system’s master. Refer to the corresponding operating manual of the master system for a detailed description of the correct procedure.

Complex signal processing

All byte-oriented signal channels such as RS232, RS485 or incremental encoders partly operate with byte lengths of more than two bytes. With the exception of the length difference, handling of these is always comparable to that of analog signals.

Calculating the effective length

The greater number of inputs or outputs defines the effective length in the InterBus system. If the number of inputs and outputs does not correspond, remaining words are inserted in the process image as „blank words“. These words are read with the contents „0000hex“ and writing to these addresses has no effect (but the data is transferred and is stored in the bus coupler’s memory).

Starting operation and diagnostics

After power-on, the bus coupler immediately checks the connected configuration. Error-free startup is signalled by extinguishing of the red „I/O ERR“ LED. Flashing of the „I/O ERR“ LED indicates an error in the area of the terminals. The error code can be determined by the frequency and quantity of flashing. This enables swift troubleshooting.

The diagnostic LEDs

The bus coupler has two groups of LEDs to provide a status indication. The top group with four LEDs indicates the status of the respective InterBus system. The meanings of the „Field bus status LEDs“ are explained in the corresponding chapters of this manual. These correspond to the usual field bus displays.

There are two further green LEDs on the top right hand side of the bus coupler to indicate the supply voltage. The left LED indicates the 24V power supply of the bus coupler. The right LED signals the supply to the Power contacts.

Local errors

Two LEDs, the „I/O-LEDs“, in the area under the aforementioned field bus status LEDs, serve to indicate the operating states of the bus terminals and connection to these bus terminals. The green LED lights up to indicate error-free operation. Error-free means that communication with the field bus system is also running without errors. To indicate errors, the red LED flashes at two different frequencies. Errors are coded in the flashing code as follows:

Flashing code

fast flashing	Start of the error code
first slow sequence	Error code
second slow sequence	Error argument

Errors

Error code	Error argument	Description
1 pulse	0	EEPROM checks on error
	1	Inline code buffer overflow
	2	Unknown data type
2 pulses	0	Programmed configuration Invalid table entry / bus coupler
	n (n > 0)	Table comparison (terminal n) invalid
3 pulses	0	Terminal bus command error
4 pulses	0	Terminal bus data error
	n	Breakage after terminal n (0: coupler)
5 pulses	n	Terminal bus error during register communication with terminal n
6 pulses	0	More than 32 words data width fitted on the bus coupler
	n (n > 0)	

Error location

The number of pulses in the error segment indicates the position of the last bus terminal before the error. Passive bus terminals such as a supply terminal without diagnostics are not counted.

The bus coupler does not end the flashing sequence when the error is remedied. The bus coupler's operating state is still „Stop“. The bus coupler can only be restarted by switching off and switching on the supply voltage.

It is only permitted to remove and insert bus terminals from the network in the deactivated state. The electronic circuitry of the bus terminals and of the bus coupler is largely protected against destruction, but malfunctions and damage cannot be ruled out when they are plugged together under voltage.

Field bus error

The top four LEDs indicate the operating states of InterBus communication. The bottom two LEDs indicate local communication between the bus coupler and bus terminals (as explained above).

*Default setting
Observe modification by
KS2000*

However, there is a relationship between the bottom green I/O RUN-LED and the field bus when the bus coupler is switched to the „SYNCHRO-NOUS“ mode. Then the I/O RUN-LED only lights up in connection with access on the internal K-Bus. That is to say, the green I/O RUN-LED does not light up until data exchange via the field bus is commenced. This means that the field bus must access the bus coupler. This relationship does not apply in the bus coupler’s default setting (FREERUN). In this state, the I/O RUN - LED is independent of the InterBus status.

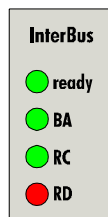

The fieldbus status LEDs indicate the operating states of the field bus. The functions of the InterBus system are indicated by the „ready“, „BA“, „RC“ and „RD“ LEDs.

The meanings of the LEDs on the BK4000					
ready	BA	RC	RD	Meaning	Remedy
lit	off	off	off	The bus coupler is ready	
lit	lit	lit	off	Remote bus active Data transfer with Master running	
lit	off	lit	off	Incoming field bus connection has been established, no connection	
lit	lit	off	lit	Continuing remote bus is off, owing to a cable fault or deactivated by the Master	Search for a cable discontinuity or a short-circuit of the master.
off	off	off	off	No function, power failure	

The green I/O LED lights up in connection with access to the internal K-Bus. However, the bus coupler interrogates the configuration of the bus terminals after power on and does not perform a data exchange with the terminals. That is to say, the red I/O LED goes off after an error-free start up without the green I/O LED having to light up. The green I/O LED does not light up until data exchange is begun (see above).

ID code and ID length

ID code and ID length

In the ID cycle, which is run through to initialise the InterBus system, the connected stations inform each other of their functions and their byte lengths. After switching on, the InterBus coupler determines its length in the InterBus during the initialisation phases of the bus terminals and generates a corresponding ID code. The InterBus coupler reports as a digital or analog „external coupler“ of variable length. The length results from the nature and number of fitted bus terminals.

Structure of the InterBus ID code

The InterBus ID code consists of 2 bytes. The MSB describes the length of the data words that are transferred. Bits 13, 14 and 15 can transfer messages. The LSB describes the type of the bus station in relation to the signal type and other features such as remote bus / peripheral bus station, PPC, ENCOM or DRIVECOM. The InterBus coupler BK4000 uses six IDs for inputs / outputs, inputs and outputs (x1hex, x2hex, x3hex). The IDs are

used depending on the type of the bus terminals, i.e. analog or digital (3xhex, 0xhex). These are the identifiers for remote bus stations from third-party manufacturers.

If there are analog and digital terminals on one BK4000, the bus coupler uses the analog identifier 3xhex. The following table shows an overview.

Signal type	Signal direction	HEX-Value
Digital	INPUTS	02
Digital	OUTPUTS	01
Digital	INPUTS/OUTPUTS	03
Analog	INPUTS	32
Analog	OUTPUTS	31
Analog	INPUTS/OUTPUTS	33

The length information is coded automatically from 0 to 32 words. A standard length of up to 9 words is supported by every bus master. The length up to 32 words is only supported from firmware version 3.2 and higher. Please pay attention to lengths greater than 10 words.

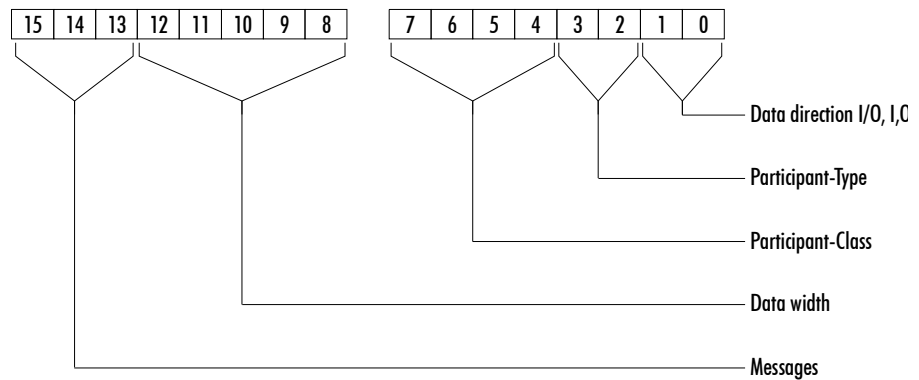

Depending on the configuration software for the InterBus master interfaces, the length and the ID code are entered separately or as a value in „16-bit hex format“.

Most configuration programs permit reading of the actual configuration by the master. The following table shows the possibilities of the length code.

Length of fitted periphery	Register width in the ID code
0	0
1 Word	1 Word
2 Words	2 Words
3 Words	3 Words
4 Words	4 Words
5 Words	5 Words
6 Words	6 Words 1)
7 Words	7 Words 1)
8 Words	8 Words
9 Words	9 Words
10 Words	10 Words 1)
11 - 12 Words	12 Words 1)
13 - 14 Words	14 Words 1)
15 - 16 Words	16 Words 1)
17 - 24 Words	24 Words 1)
25 - 32 Words	32 Words 1)

1) The data widths are only supported from Firmware version 3.20 and higher by the interfaces of the PLC and from driver version 2.0 by the PC card.

Remark:

In InterBus master interfaces with firmware versions less than 4.0, the peripheral data block of a bus coupler can only be placed in the process image as a coherent block with one base address. All following data of the block is assigned to the subsequent addresses.

Register expansion

The differing length of the bus coupler is realised by a register expansion. The number of additional registers is switched by the internal micro processor. The length is determined after power-on or after a reset and is written into a register expansion module as a numeric value. A change in the length is not possible without interrupting the exchange of data on the InterBus. The BK4000 must be restarted by means of a reset. The master must be reconfigured to the new length. In the auto configuration mode of some InterBus masters, the master starts even after the length of individual slaves has been modified if this does not result in any overlapping of addresses.

Run times and reaction times

Transfer of the signals from the input into the controller and from the controller to the outputs requires a run time. This is composed of various portions, i.e. transfer from the controller to the master; transfer via the InterBus and transfer from the bus coupler to the outputs. It applies conversly in the return direction.

Controller / master

Refer to the master manufacturer's data for details of the reaction time from the controller to the Master. The newly transferred data does not acquire validity until one cycle has been transferred completely.

The reaction time TIBS on the InterBus is composed of the following. The constants SW, M, N and TBIT constitute the sum of the cycle time in ms. In the worst case, the reaction time is 2 x cycle time because the data does not acquire validity until after the end of the cycle.

$$\text{TIBS} = (\text{SW} + (13 * (6 + \text{N}) + 1,5 * \text{M}) * \text{TBIT}) * 2$$

SW = 0.2 ms
M = Number of bus couplers
N = Number of effective byte lengths
TBIT = 0.002 ms

Pay attention to the number of bytes and not the word length in the calculation of the times.

Note:

Pay attention to particular delays in the event of transmission errors. The InterBus requires 5 cycle times until the next valid data can be exchanged.

K-Bus reaction time

The reaction time on the K-Bus is determined by shifting / reading and saving of the data. The following table contains measured values for typical setups. It is possible to extrapolate to larger figures.

Terminals fitted on the bus coupler			Run time on the K-Bus
Digital OUT	Digital IN	Analog IN/OUT	T_cycle (us)
4	0	0	150
8	0	0	170
12	0	0	170
16	0	0	200
20	0	0	200
24	0	0	220
28	0	0	220
32	0	0	245
0	4	0	150
0	8	0	180
0	12	0	180
0	16	0	200
0	20	0	200
0	24	0	230
0	28	0	230
0	32	0	250
4	4	0	170
8	8	0	195
12	12	0	220
16	16	0	250
20	20	0	275
24	24	0	300
28	28	0	325
32	32	0	350
4	4	1 (KL3202)	630
4	4	2 (KL3202)	700

InterBus coupler BK4000 in InterBus S

Presentation of the system

The InterBus system is structured as a data ring based on a central master/slave access method. It has the structure of a spacially distributed shift register. With its registers of differing length, each unit is part of this shift register ring, through which the master shifts the data serially.

Use of the ring structure offers the possibility of synchronous sending and receiving of data. The two data directions of the ring are accommodated in one cable.

Each station in the InterBus system has an ID register (identification register). This register contains information about the module type, the number of input and output registers and status and error states.

The InterBus system basically has two operating modes:

- The ID cycle, which is run through to initialise the InterBus system and whenever requested. In the ID cycle, the interface module reads the ID registers out of all devices on the bus system and builds up the process image on the basis of this information.
- The data cycle, the actual work cycle, which handles data transfer. In the data cycle, the input data from all devices is transferred out of the registers into the interface module and output data is transferred from the interface module to the devices.

System configurations and device types

The InterBus Club carries a large number of different ID codes. Except for 6 ID codes, these ID codes are used up for couplers of digital and analog peripherals from Phoenix Contact. Therefore, manufacturer identification via the ID code is not possible. (Refer to the chapter entitled „ID code and ID length“ for detailed explanations). Handling of the InterBus BK4000 does not differ from the units from other manufacturers.

The medium: connector and cable

Remote bus connection

The InterBus distinguishes between the remote bus, the peripheral bus and the installation remote bus. The InterBus coupler is equipped with the remote bus interface. The Interbus coupler has an incoming and outgoing interface on the basis of a D-SUB connector and coupling.

Assignments on the connector and coupling of the remote bus cable

Outgoing remote bus,
9-pole D-SUB connector

Cable

Incoming remote bus,
9-pole D-SUB coupling

/DO	6	green
DO	1	yellow
/DI	7	pink
DI	2	grey
COM	3	brown
	5	Jumper
	9	Jumper

6	/DO
1	DO
7	/DI
2	DI
3	COM

BK4500 InterBus Coupler and fibre optic connection

Fibre optic conductor: the InterBus Club elaborated the specification of a transmission technology based on fibre optic conductors for applications in highly interference-prone environments and also to increase the range. For the Beckhoff InterBus bus coupler with fibre optic connection (BK4500) use is made of F-SMA connectors and, in this case, the length between two stations is 1-40 m. Attention must be paid to ensuring that the slide switch for activating and deactivating the continuing interface is set to the corresponding position. If the BK4500 is the last InterBus station in the ring, the switch must be set to the OFF/END position. It must be set to the ON/NEXT position if the BK4500 is in a position in the ring.

BK4500

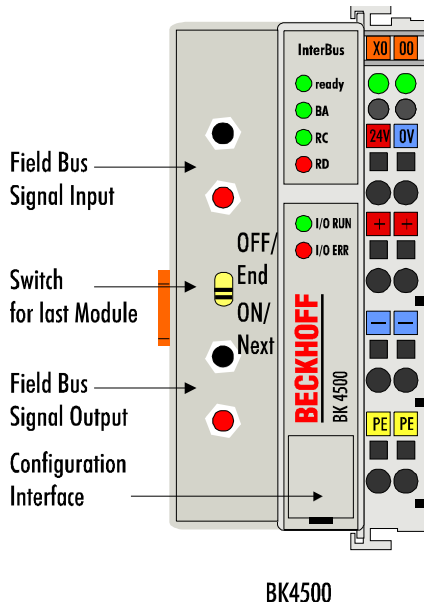

RS-422 transfer in accordance with the InterBus standard

Fundamental characteristics	
Network topology	Ring with integrated return line
Medium	Shielded twisted-pair cable, 3x twisted-pair with shield
Number of modules between two stations	256
between two stations	400 m
Total length	12.8 km
Data transfer rate	500 Kbits/s
Connector	9-Pin D-Sub plug connector and 9-pin D-Sub socket

Wiring for InterBus

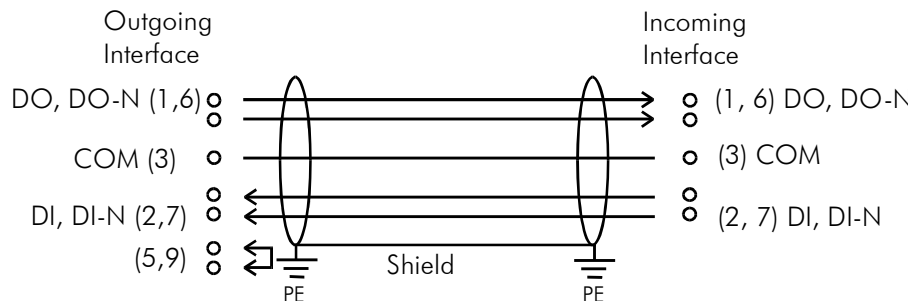

In systems with more than two modules, all modules are wired in succession. The ends of the bus cable must be terminated with resistors, which are located in each module. A jumper in the connector of the continuing interface signals to the bus coupler that a further modules follows.

To be able to realise uninterrupted operation, none of the connectors must be withdrawn and all modules in the ring must be operable.

Configuration of masters

As already explained above, the InterBus coupler creates a data area with input and output bytes. The affiliations between channels of the bus terminal and the bits and bytes of the process image are set by the bus coupler.

The InterBus master exchanges a coherent input and output data block with each InterBus coupler. The affiliations of the bytes from this data block to the addresses of the process image are established via data blocks of the PLC or the IBS SYS SWT or IBS CMD SWT G3 and G4 configuration software from Phoenix Contact. For other masters, use the manufacturer's corresponding tools.

Master configuration software

Master / software	Configuration software	Manufacturer
PLC-Interfaces versions < 4	IBS SYS SWT	Phoenix Contact
	IBS CMD SWT G3	
PC interface version < 4	IBS SYS SWT	Phoenix Contact
	IBS CMD SWT G3	
PLC-interfaces versions >4	IBS CMD SWT G4	Phoenix Contact
PC interfaces versions >4	IBS CMD SWT G4	Phoenix Contact

Ensuring data consistency

Consistency of a station's data is ensured by the data transfer protocol of the InterBus. Consistency throughout the entire process image is ensured by synchronous sampling.

Asynchronous access by the controller's CPU (mostly PLC) to the data area of the InterBus master may lead to inconsistencies. Most InterBus masters ensure access to 16-bit words and, to some extent, also to 32-bit double words. Please refer to the corresponding manufacturer's manuals for further details of special access methods relating to the master interfaces.

The S5 modules IBS S5 DCB and IBS S5 DSC as InterBus masters are common PLC interfaces.

The masters featuring firmware version 4.0 are particularly convenient to operate. The CMD configuration software allows users to define the settings under Windows. Byte-by-byte and also bit-by-bit allocation of the peripheral data in the controller's address area is possible. Data consistencies can be selected in groups.

Conformity with the InterBus standard

The BK4xxx operate with the SUP1 3 (Serial Universal Peripheral Interface) protocol chip. The SUP1 3 protocol chip handles the complete InterBus protocol. In comparison with the predecessor versions (SUP1 2), the SUP1 3 offers extended diagnostic and error management. Please refer to the manuals of the Interbus masters used for details of the supported functionalities of the SUP1 3 chips.

Annex

Example: combination of a process image in the bus coupler

An example explains the affiliations of the input and output channels to the process image. Our example setup should consist of the following bus terminal modules:

In this configuration, the bus coupler creates the allocation list that follows below

Position	Function module on the busbar
POS00	Bus coupler
POS01	Digital inputs, 2 channels
POS02	Digital inputs, 2 channels
POS03	Digital inputs, 2 channels
POS04	Digital inputs, 2 channels
POS05	Digital inputs, 2 channels
POS06	Digital inputs, 2 channels
POS07	Digital outputs, 2 channels
POS08	Digital outputs, 2 channels
POS09	Digital outputs, 2 channels
POS10	Analog inputs, 2 channels
POS11	Analog outputs, 2 channels
POS12	Analog outputs, 2 channels
POS13	Analog inputs, 2 channels
POS14	Infeed terminal
POS15	Digital inputs, 2 channels
POS16	Digital inputs, 2 channels
POS17	Digital inputs, 2 channels
POS18	Digital outputs, 2 channels
POS19	Digital outputs, 2 channels
POS20	Analog outputs, 2 channels
POS21	End terminal

By default, InterBus, DeviceNet and Profibus couplers only map signal channels of 16-bits width. The CONTROL/STATUS BYTE is not available. That is to say, an analog input terminal with 2 channels, for example, appears in the process image with 2 x 16 bits. The figures showing the byte addresses and the affiliations differ correspondingly when CONTROL/STATUS is activated.

Part for byte-oriented data, analog outputs

relative byte address	Bit position	Process image in the controller	Position in the block
0, 1	none	A0, A1	POS11
2, 3	none	A2, A3	POS11
4, 5	none	A4, A5	POS12
6, 7,	none	A6, A7	POS12
8, 9	none	A8, A9	POS20
10, 11	none	A10, A11	POS20

Part for bit-oriented, data, digital outputs

relative byte address	Bit position	Process image in the controller	Position in the block
12	0	A12	POS07
12	1	A12	POS07
12	2	A12	POS08
12	3	A12	POS08
12	4	A12	POS09
12	5	A12	POS09
12	6	A12	POS18
12	7	A12	POS18
13	0	A13	POS19
13	1	A13	POS19

Part for byte-oriented data, analog inputs

relative byte address	Bit position	Process image in the controller	Position in the block
0, 1	none	E0, E1	POS10
2, 3	none	E2, E3	POS10
4, 5	none	E4, E5	POS13
6, 7	none	E6, E7	POS13

Part for bit-oriented data, digital input

relative byte address	Bit position	Process image in the controller	Position in the block
8	0	E8	POS01
8	1	E8	POS01
8	2	E8	POS02
8	3	E8	POS02
8	4	E8	POS03
8	5	E8	POS03
8	6	E8	POS04
8	7	E8	POS04
9	0	E9	POS05
9	1	E9	POS05
9	2	E9	POS06
9	3	E9	POS06
9	4	E9	POS15
9	5	E9	POS15
9	6	E9	POS16
9	7	E9	POS16
10	0	E10	POS17
10	1	E10	POS17

Positions POS14 and POS21 are not relevant with regard to data transfer. They do not appear in the list. If a byte is not used completely, e.g. E8, the bus coupler pads the remaining bits of the byte with zeros.

Overview of the process image breakdown in the bus coupler:

Output data in the bus coupler

A0	byte oriented data
...	
A11	
A12	bit oriented data
A13	

Input data in the bus coupler

E0	byte oriented data
...	
E7	
E8	bit oriented data
...	
E10	

The base addresses E0 and A0 listed here apply as relative addresses or addresses in the bus coupler. In the bus master software, a base peripheral address may be assigned to the base address of the bus coupler. All following addresses are automatically assigned the successive addresses depending on the length of the actual data words.

Firmware version 4.0 and higher of the InterBus interfaces:

The bus master may place the addresses in a freely chosen location in the controller's process image. The masters's configuration software enables any chosen assignment of the bytes to the addresses of the process image in the controller.

Representation of analog signals in the process image

Each analog channel consists of three input bytes and three output bytes. In the standard case, however, an analog channel only requires one data word in the process image. These two bytes represent the value as a signed integer, i.e. 15 bits with sign. The data format is used regardless of the actual resolution. For example: in the case of a resolution of 12 bits, the four least significant bits are of no relevance. By means of the KS2000 configuration software, the third byte can be inserted in the process image for any channels. The least significant byte has control and status functions. Various operating modes can be set with the control byte. The six least significant bits can be used as addressing bits. Addressing serves to read and write a register set. The register set has 64 registers and allows setting of different operating parameters, for example selection of a thermocouple type or representation of a value in a different numerical format.

I/O bytes of an analog channel in the process image

Output byte 1	Output byte 0	Control byte
Input byte 1	Input byte 0	Status byte

Significance of the control/status byte for access to the register model

BIT 7	0 = NORMALMODE, 1 = CONTROL MODE
BIT 6	0 = READ, 1 = WRITE
BIT 5	Register address, MSB
BIT 4	Register address
BIT 3	Register address
BIT 2	Register address
BIT 1	Register address
BIT 0	Register address, LSB

Register set of an analog channel

63			
47			
31			
	15		User area
	0		
16	OFF	SET	Manufacturer settings
	GA	IN	
		Software Vers.	Type
0	Length	Typ	Auxiliary process image

This representation is not accessible in the bus coupler's default. The KS2000 software is needed.

The meanings of the registers and of the status bytes are explained in the bus terminal's corresponding data sheets. As far as its structure is concerned, the module is identical for all bus terminals that enable more extensive signal processing.

Support and Service

Beckhoff and their partners around the world offer comprehensive support and service, making available fast and competent assistance with all questions related to Beckhoff products and system solutions.

Beckhoff's branch offices and representatives

Please contact your Beckhoff branch office or representative for local support and service on Beckhoff products!

The addresses of Beckhoff's branch offices and representatives round the world can be found on her internet pages: <http://www.beckhoff.com>

You will also find further documentation for Beckhoff components there.

Beckhoff Headquarters

Beckhoff Automation GmbH

Eiserstr. 5

33415 Verl

Germany

phone: + 49 (0) 5246/963-0

fax: + 49 (0) 5246/963-198

e-mail: info@beckhoff.com

web: www.beckhoff.com

Beckhoff Support

Support offers you comprehensive technical assistance, helping you not only with the application of individual Beckhoff products, but also with other, wide-ranging services:

- support
- design, programming and commissioning of complex automation systems
- and extensive training program for Beckhoff system components

hotline: + 49 (0) 5246/963-157

fax: + 49 (0) 5246/963-9157

e-mail: support@beckhoff.com

Beckhoff Service

The Beckhoff Service Center supports you in all matters of after-sales service:

- on-site service
- repair service
- spare parts service
- hotline service

hotline: + 49 (0) 5246/963-460

fax: + 49 (0) 5246/963-479

e-mail: service@beckhoff.com