

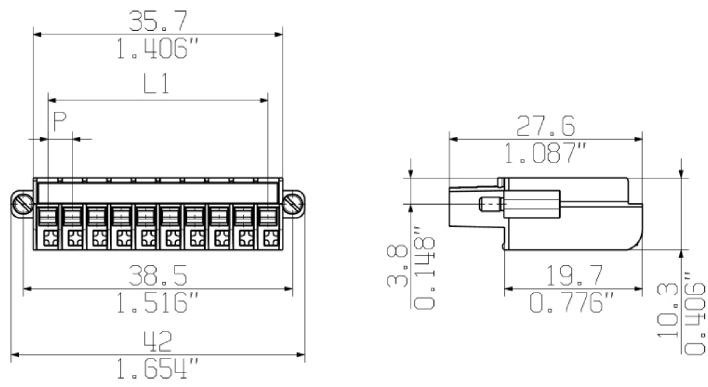

ZS2001-0005 | female header with spring connection as IP 20 plug-in connection level for KM or EM modules, EP2316-0003, EPP2316-0003 and IE2403, 1 x 10-pin, without LED, labeling 1...10

female, 10-pin

Electrical data	
Rated voltage	50 V
Rated current	2 A at 20 °C (according to IEC 60664-1, IEC 61984)
Shielding	no
Insulation resistance	1 GΩ
Mechanical data	
Contact type	female
Number of positions (face)	10-pin
Wire termination	Clamping yoke connection
Mating cycles	25
Insertion force	8 N / pol
Weight per piece	0.023 kg (0.0507 lb)
Body colour	grey
Contact carrier material	PBT
Contact material	CuZn
Max. wire cross section	AWG 24...AWG16 (0.2 mm ² ...1.5 mm ²)
Environmental data	
Special features	with labeling 1...10
Protection class	IP 20
Pollution level	3
Approvals	UL



Notes

- Illustrations similar

Ordering information	
ZS2001-0005	female header with spring connection as IP 20 plug-in connection level, for KM or EM modules, EPxxx-0003, EPPxxx-0003 and IE2403, 1 x 10-pin, without LED, labelling 1...10

Beckhoff®, TwinCAT®, EtherCAT®, EtherCAT G®, EtherCAT G10®, EtherCAT P®, Safety over EtherCAT®, TwinSAFE®, XFC®, XTS® and XPlanar® are registered trademarks of and licensed by Beckhoff Automation GmbH. Other designations used in this publication may be trademarks whose use by third parties for their own purposes could violate the rights of the owners.

© Beckhoff Automation GmbH & Co. KG 05/2020

The information provided in this brochure contains merely general descriptions or characteristics of performance which in case of actual application do not always apply as described or which may change as a result of further development of the products. An obligation to provide the respective characteristics shall only exist if expressly agreed in the terms of contract.