

# Montageanleitung B12 Hybrid

konfektionierbares Steckergehäuse mit Crimpanschluss, axial,  
2x0,75mm<sup>2</sup> + 4xAWG22, ENP: Powerbuchse / Datenstift

## Stückliste

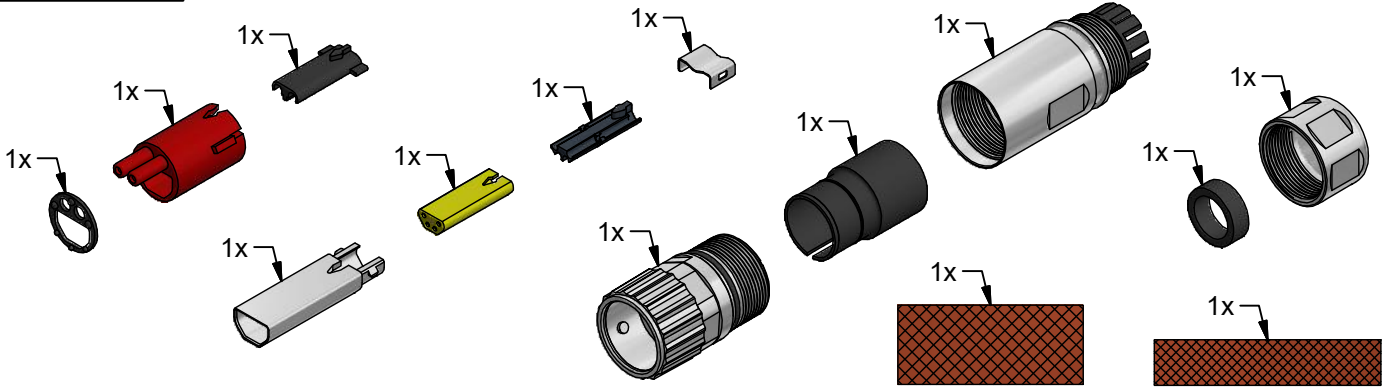

1 Einzelteile auf Leitung schieben

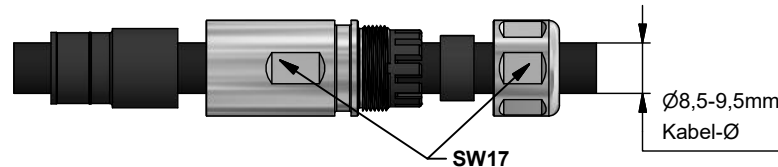

**Laufrichtung beachten!**

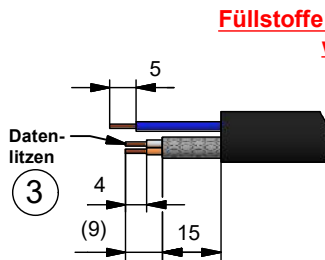
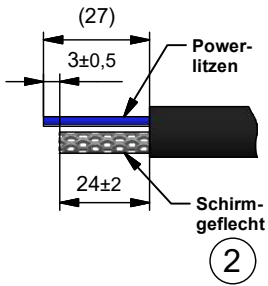

**Füllstoffe bündig mit Kabelmantel wegschneiden!**

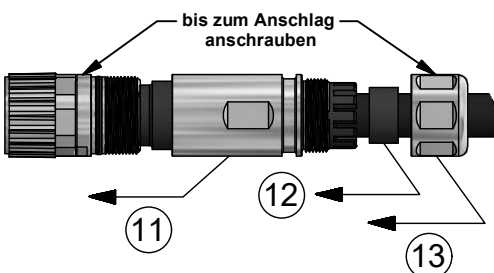
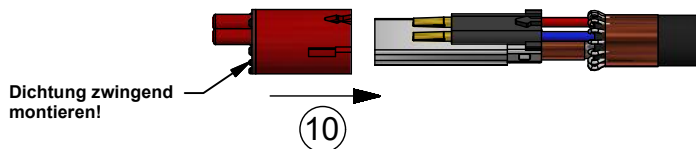
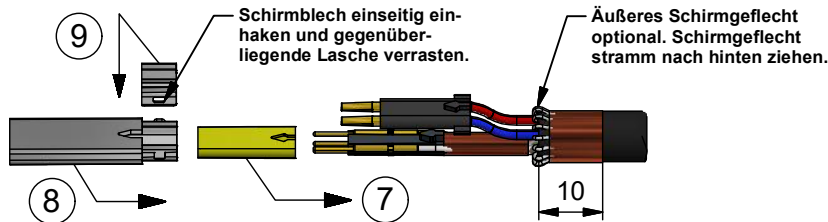
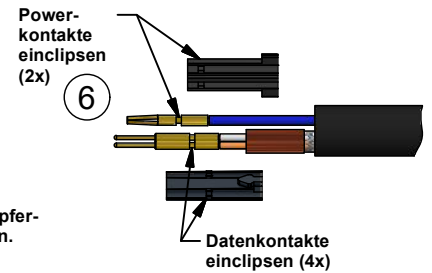
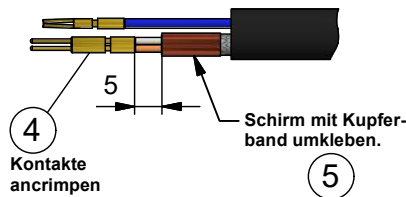

Farbring optional  
ZS7100-B006 (gelb)  
ZS7100-B008 (grün)

**Achtung: Ansicht von Kabelausgang dargestellt! Auf richtige Farbwahl achten!**

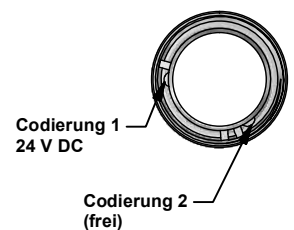
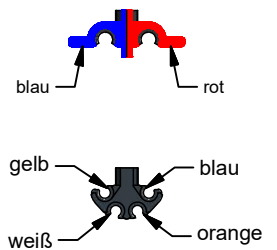

### Werkzeug / Zubehör

Crimpzange	Crimpeinsatz / Locator
ZB8810-0000	ZB8810-0001

**BECKHOFF**

790-944600 / 7901A071 Rev. b  
Beckhoff Art.-Nr.: ZS7100 - A002

# Assembly instruction B12 hybrid

field attachable plug housing with crimp connection, axial,  
 2x0.75mm<sup>2</sup> + 4xAWG22, ENP: power (female) / data (male)

## parts list

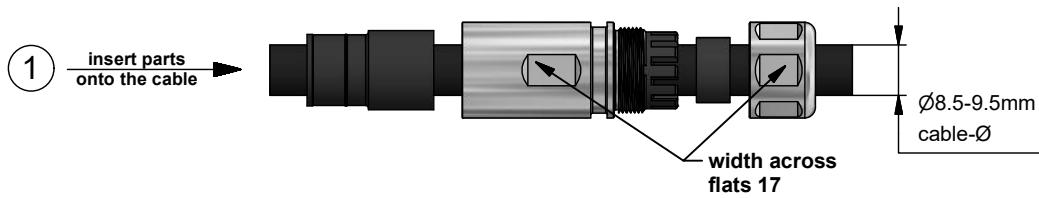
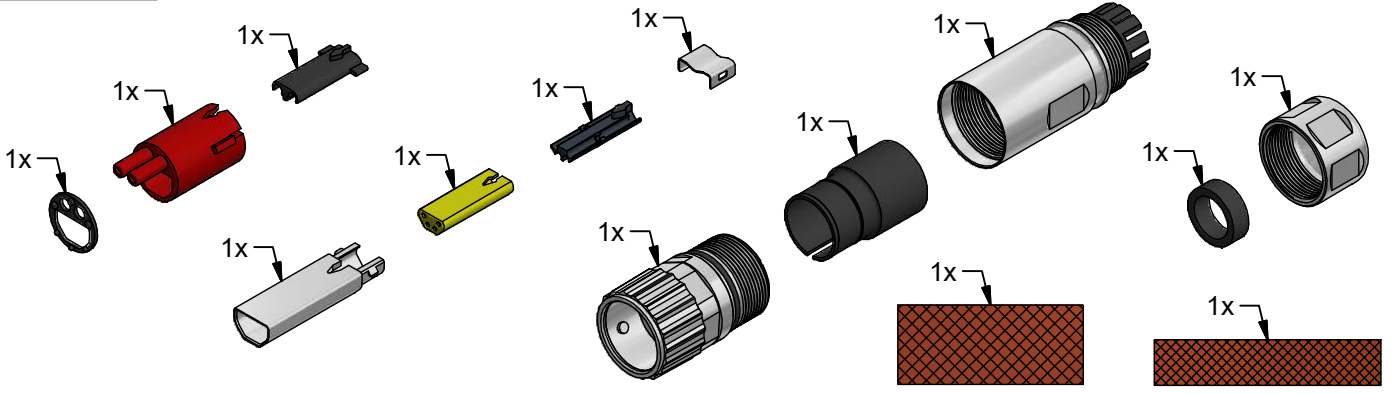

Please consider the cable direction!

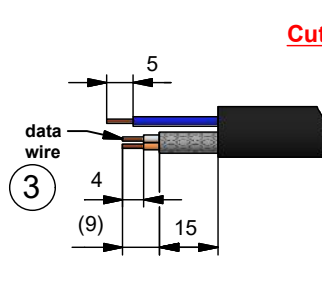
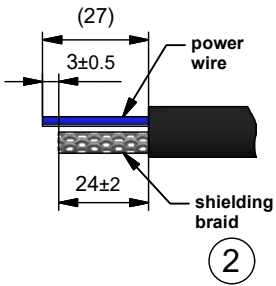

Cut off the fillers!

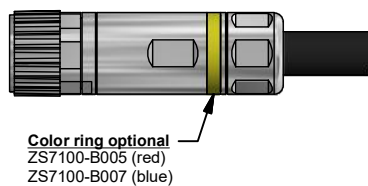
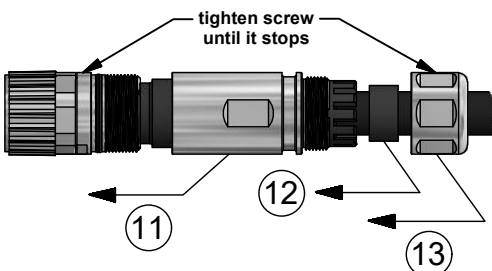
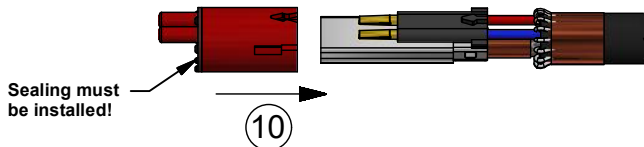
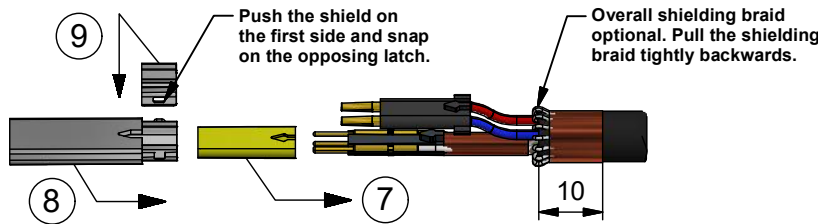
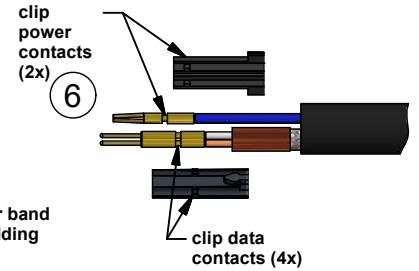
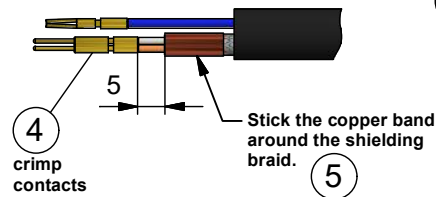

Attention: View from cable outlet!  
 Consider the right choice of colors!

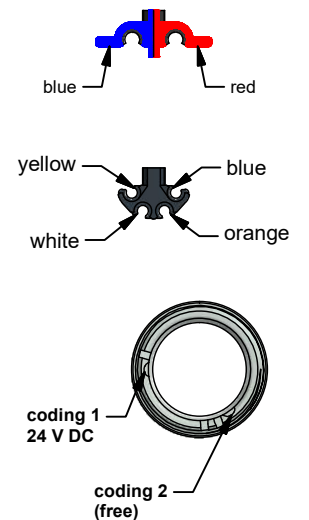

## tools / accessory parts

crimping tool	crimping insert / locator
ZB8810-0000	ZB8810-0001

**BECKHOFF**

790-944600 / 7901A071 Rev. b  
 Beckhoff art.-no.: ZS7100 - A002