

# Operating Manual

## **Crimp system tool for B12 / B17 / B23 and M8 P-coded connector series**



## Table of contents

1.	General	3
2.	Intended use	3
3.	Description	3
4.	Changing die sets/crimping procedure	4
4.1.	Changing the die set/installing the locator and wire stop	4
4.2.	Crimping procedure	4
5.	Emergency release of force lock	5
6.	Setting the crimp height	5
7.	Guarantee	6
8.	Service and maintenance	6

### **Beckhoff Automation GmbH & Co. KG**

Hülshorstweg 20

33415 Verl

Germany

Fon: + 49 (0) 52 46 / 9 63 - 0

Fax: + 49 (0) 52 46 / 9 63 - 1 98

[info@beckhoff.de](mailto:info@beckhoff.de)

[www.beckhoff.de](http://www.beckhoff.de)

Beckhoff®, TwinCAT®, EtherCAT®, EtherCAT P®, Safety over EtherCAT®, TwinSAFE®, XFC® and XTS® are registered trademarks of and licensed by Beckhoff Automation GmbH. Other designations used in this publication may be trademarks whose use by third parties for their own purposes could violate the rights of the owners.

© Beckhoff Automation GmbH & Co. KG 08/2016

The information provided in this brochure contains merely general descriptions or characteristics of performance which in case of actual application do not always apply as described or which may change as a result of further development of the products. An obligation to provide the respective characteristics shall only exist if expressly agreed in the terms of contract.

## 1. General

Keep the Operating Instructions with the crimp system tool at all times. This crimp system tool features state-of-the-art technology and complies with recognised safety regulations. The Crimping tool may be used only in a technically fault-free condition, in a safety-conscious manner with consideration given to potential hazards, and may be used only for the purpose described in the Operating Instructions.

Attention

**The manufacturer is not liable for any damages that occur as a result of unauthorized modifications made to the hand crimping tool or its improper use. Always isolate wires from the power supply!**

## 2. Intended use

- Crimping of pin and socket contacts
- Use of different die sets enables a broad range of applications

## 3. Description

The crimp system tool consists of a set of pliers (1) with a setting dial (2) and emergency release (3), a split crimping die (4), two fixing bolts (5) for the upper and lower die and (if required) a positioning guide (6, locator). Positioning guides can be retrofitted to match the connector type. The crimping force can be adjusted (see also section "Setting the crimping height"). The crimp system tool utilises a ratchet mechanism. The crimper opens automatically only after passing the last ratchet pawl (force operation to complete). In the event of a faulty crimp, the emergency release can be used to open the crimper early, so as to avoid damaging the crimping die or the connector.



## 4. Changing die sets/crimping procedure

### 4.1. Changing the die set/installing the locator and wire stop

- A die set consists of an upper (3) and lower (4) die
- Remove bolts 1 and 2
- Remove the upper (3) and lower (4) die
- Insert new upper (3) and lower (4) die
- Close the tool until the upper (3) and lower (4) die can centre themselves
- Tighten bolts 1 and 2
- To install an optional locator, replace bolt 2 on the lower die with bolt M 4x15
- Screw the locator (5) onto the tool and, depending on the locator type, secure using an Allen key or open-ended wrench
- To install an optional wire stop (7), replace bolt 1 on the upper die with bolt M 4x25
- Holding the wire stop (7) against the tool, thread bolt 8 through the upper die (4) and secure using the nut supplied

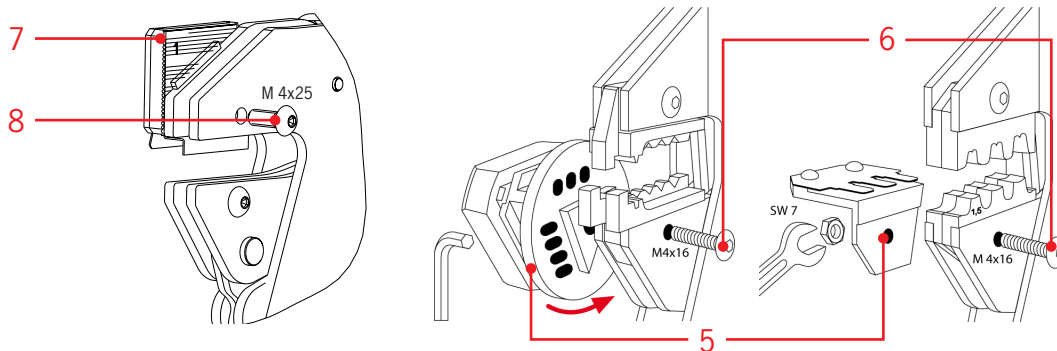
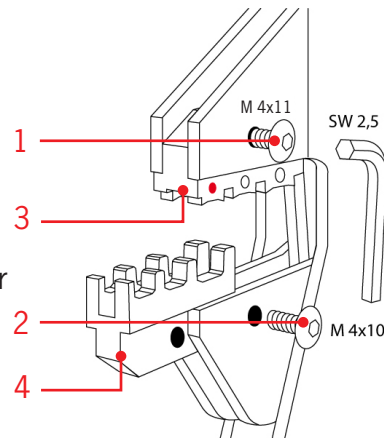

### 4.2. Crimping procedure

1. Install the die set and any accessories (see 4.1)
2. Strip the cable to a suitable length (observe manufacturer's instructions)
3. Depending on cross-section, place the connector in the die set or the appropriate place in the locator and use the tool to hold in place. Insert cable into connector.
4. Close the crimper and open after passing the last ratchet pawl (force lock)

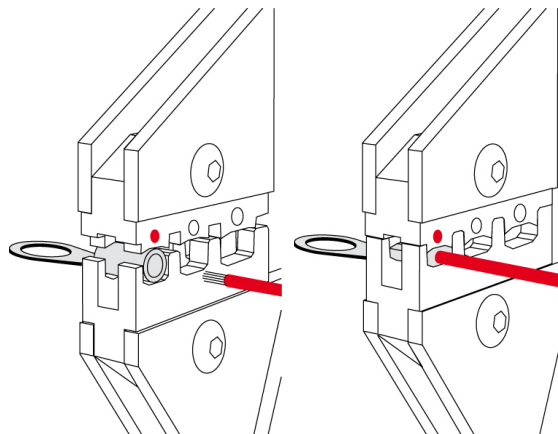

## 5. Emergency release of force lock

The force lock opens automatically if the crimp procedure completes in full. In case the crimp procedure needs to be interrupted, the force lock can be released by pressing the shanks together slightly, then unlocking the emergency release by using the included allen key with handle.

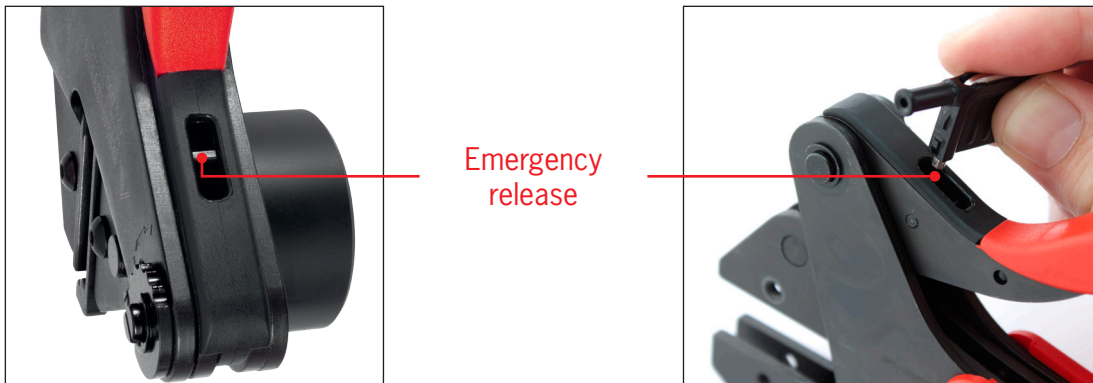

## 6. Setting the crimp height

The crimping force applied by the tool is set at the factory. The manual force applied when the tool is empty is 130–180 N. The crimping dies and hand tool are matched to one another to ensure this force produces an optimum crimp. If the results of crimping do not meet the specifications set by the connector manufacturer (crimp height, extraction force), this may have the following causes:

Error	Possible cause	Solution
Crimping results do not meet specifications set by the connector manufacturer	Wrong die set or wrong crimp nest	Install the die set appropriate to the application and ensure you work with the correct crimp nest
	Wrong cable	Use cable as specified by the connector manufacturer
	Wear to the tool as a result of normal use	Recalibrate the crimping force
	Wear to the die set	Replace die set to avoid damage

**Attention**

**The crimp height should be checked regularly by qualified personnel from quality control and recalibrated as required using the method described below.**

1. Using a screwdriver, remove the slotted headless screw **1**.
2. If the setting dial **2** is rotated counter-clockwise (+), this configures a stronger crimp force and a smaller crimp height.
3. If the setting dial is rotated clockwise (-), this configures a weaker crimp force and thus a greater crimp height. Regulation of the hand force should not exceed 180 N.
4. If bolt aperture **3** is used, it becomes possible to alter the crimp force by only half a notch. This enables very fine-grained adjustments to be made to the crimp force.
5. Replace the slotted headless screw
6. Prior to using the crimper, it must be ensured that the adjusting disc is properly secured with the slotted headless screw.

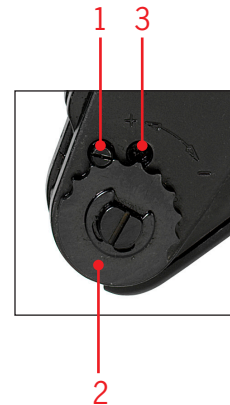

---

## 7. Guarantee

The crimp system tool is subjected to a thorough quality control process. General warranty conditions apply.

---

## 8. Service and maintenance

Before starting work, ensure that the crimp system tool is clean and in proper working order. Crimping residue must be removed. Joints should be regularly oiled with a light mineral oil and protected against contamination. It must be ensured that all bolts are secured by means of securing rings. Check that the setting dial is secured tightly by the slotted headless screw. Maintenance of the crimper should be performed by the manufacturer.

---