

Documentation | EN

PS1011-2410-0000

Power supply 24 V DC, 10 A, 1-phase, AC 100-240 V



Table of contents

1 Overview	5
2 Foreword	6
2.1 Notes on the documentation	6
2.2 Terminology and abbreviations	7
2.3 Safety instructions	8
3 Technical data, mounting, wiring	10
3.1 AC input	10
3.2 DC input	11
3.3 Input inrush current	12
3.4 Output	13
3.5 Hold-up time	14
3.6 DC-OK relay contact	15
3.7 Efficiency and losses	16
3.8 Lifetime expectancy and MTBF	17
3.9 Terminals and wiring	18
3.10 Functional wiring diagram	19
3.11 Front side and operating elements	20
3.12 EMC	21
3.13 Environment	22
3.14 Protective functions and safety features	23
3.15 Dielectric strength	24
3.16 Declaration of conformity and approvals	25
3.17 Dimensions and weight	26
4 Application notes	27
4.1 Peak current capability	27
4.2 Back-feeding loads	28
4.3 External input protection	28
4.4 Parallel use to increase power	28
4.5 Parallel use for 1+1 redundancy	29
4.6 Series connection	30
4.7 Inductive and capacitive loads	30
4.8 Charging batteries	30
4.9 Operation on two phases	30
4.10 Use in a tightly sealed enclosure	31
5 Disposal	32
6 Appendix	33
6.1 Accessories	33
6.2 Documentation issue status	35
6.3 Support and Service	36

1 Overview

PS1011-2410-0000 | Power supply 24 V, 10 A, 1-phase



- AC 100-240V wide-range input
- Active power factor correction PFC
- Width only 49mm
- Efficiency of up to 95.2%
- Full power between -25°C and +55°C
- DC-OK relay contact

The PS1011-2410-0000 is a 1-phase 24 V power supply with an output current of 10 A and an output power of 240 W.

On the input side, the device features a wide-range input, active power factor correction (PFC) and inrush current limiting.

The output operates according to the UI characteristic curve and switches to the safe hiccup mode in case of overload/short-circuit.

The power supply is part of the PS1000 family and has a width of 49 mm. A DC OK LED and a potential-free relay contact monitor the status of the output voltage.

Overview of technical data ^{*)}

Overview of technical data	PS1011-2410-0000
Output voltage	DC 24V
Adjustment range	24 - 28V
Output current	10A (at 24V, amb.< +55°C) 6.25A (at 24V, amb.< +70°C) 8.6A (at 28V, amb.< +55°C) 5.4A (at 28V, amb.< +70°C)
Output power	240W (amb.< +55°C) 150W (amb.< +70°C)
Input voltage AC	AC 100-240V ±10%
Mains frequency	50-60Hz ±6%
Input current AC	2.17 / 1.18A at 120 / 230Vac
Power factor	0.98 / 0.93 at 120 / 230 Vac
Efficiency	94.0 / 95.2% at 120 / 230Vac
Temperature range	-25°C to +70°C
Dimensions (W x H x D)	49 x 124 x 124 mm (without DIN rail)
Weight	540 g
Approvals/markings	cULus CE, EAC, UKCA

*) All values typical for 24V, 10A, 230Vac, 50Hz, +25°C ambient temperature and after a warm-up time of five minutes, unless otherwise stated.

2 Foreword

2.1 Notes on the documentation

Copyright

© Beckhoff Automation GmbH & Co. KG, Germany.

The reproduction, distribution and utilization of this document as well as the communication of its contents to others without express authorization are prohibited.

Offenders will be held liable for the payment of damages. All rights reserved in the event of the grant of a patent, utility model or design.

Disclaimer

The documentation has been prepared with care. The products described are, however, constantly under development.

We reserve the right to revise and change the documentation at any time and without prior announcement.

No claims for the modification of products that have already been supplied may be made on the basis of the data, diagrams and descriptions in this documentation.

Trademarks

Beckhoff®, TwinCAT®, TwinCAT/BSD®, TC/BSD®, EtherCAT®, EtherCAT G®, EtherCAT G10®, EtherCAT P®, Safety over EtherCAT®, TwinSAFE®, XFC®, XTS® and XPlanar® are registered trademarks of and licensed by Beckhoff Automation GmbH. Other designations used in this publication may be trademarks whose use by third parties for their own purposes could violate the rights of the owners.

Patent Pending

The EtherCAT Technology is covered, including but not limited to the following patent applications and patents: EP1590927, EP1789857, EP1456722, EP2137893, DE102015105702 with corresponding applications or registrations in various other countries.

Intended audience



This description is only intended for the use of trained specialists in control and automation engineering who are familiar with the applicable national standards.

It is essential that the documentation and the following notes and explanations are followed when installing and commissioning these components.

The qualified personnel is obliged to always use the currently valid documentation.

The responsible staff must ensure that the application or use of the products described satisfy all the requirements for safety, including all the relevant laws, regulations, guidelines and standards.

2.2 Terminology and abbreviations

PE and the earthing symbol 	PE is the abbreviation for "protective earth" and has the same meaning as the earthing symbol 
Earth, ground	This document uses the term "earth" which is the same as the U.S. term "ground".
T.b.d.	Still to be defined, value or description will follow in due course.
AC 230 V	A value preceded by "AC" or "DC" represents a nominal voltage or a nominal voltage range. The nominal voltage or the nominal voltage range may be provided with tolerances. (e.g. AC 230 V \pm 10%). The calculated total range then indicates the working range of the device. Example: DC 12 V refers to a 12 V battery, regardless of whether it is fully charged (13.7 Vdc) or discharged (10 Vdc).
230 Vac	A value followed by the unit Vac or Vdc is an instantaneous value that does not contain any additional tolerances.
50 Hz vs. 60 Hz	Unless otherwise specified, AC 100 V and AC 230 V parameters are valid at a mains frequency of 50 Hz. AC 120 V parameters are valid for a mains frequency of 60 Hz.
may	A keyword indicating a choice without implied preference.
shall	A keyword indicating a mandatory requirement.
should	A keyword indicating a choice with a clearly preferred method of implementation.

2.3 Safety instructions

Description of instructions

In this documentation the following instructions are used.
These instructions must be read carefully and followed without fail!

DANGER

Serious risk of injury!

Failure to follow this safety instruction directly endangers the life and health of persons.

WARNING

Risk of injury!

Failure to follow this safety instruction endangers the life and health of persons.

CAUTION

Personal injuries!

Failure to follow this safety instruction can lead to injuries to persons.

NOTICE

Damage to environment/equipment or data loss

Failure to follow this instruction can lead to environmental damage, equipment damage or data loss.



Tip or pointer

This symbol indicates information that contributes to better understanding.

Intended use

This device is designed for installation in a housing and is intended for general professional use, for example in industrial control systems or office, communication and measuring equipment.

Do not use this power supply in installations where a malfunction could cause serious injury or danger to human life.

Exclusion of liability

All the components are supplied in particular hardware and software configurations appropriate for the application. Modifications to hardware or software configurations other than those described in the documentation are not permitted, and nullify the liability of Beckhoff Automation GmbH & Co. KG.

Personnel qualification

This description is only intended for trained specialists in control, automation and drive engineering who are familiar with the applicable national standards.

Safety regulations

Please note the following safety instructions and explanations!
Product-specific safety instructions can be found on following pages or in the areas mounting, wiring, commissioning etc.

Safety instructions and installation requirements for the PS1011-2410-0000 power supply**⚠ DANGER****Danger of electric shock, fire, injuries, injuries resulting in death!**

- Do not use the power supply without proper grounding (protective conductor). Use the terminal at the input terminal strip for the earth connection, not one of the screws on the housing.
- Switch off the power supply before working on the device. Provide protection against unintentional reconnection.
- Ensure proper wiring by following all local and national regulations.
- Do not modify or attempt to repair the device.
- Do not open the device, as high voltages are present inside.
- Avoid foreign bodies entering the housing.
- Do not use the device in damp locations or in areas where moisture or condensation is likely to occur.
- Do not touch the device when it is switched on or immediately after it has been switched off. Hot surfaces can cause burns.

● Further notes on installation requirements**i**

- This device contains no parts that require maintenance. If an internal fuse trips, this is due to an internal defect.
- If any damage or malfunction occurs during installation or operation, turn off the power supply immediately and return the device to the factory for inspection.
- Install the device on a DIN rail according to EN 60715, with the input terminals at the bottom of the device.
- This device is designed for convection cooling and does not require an external fan. Do not obstruct the air circulation. No more than 15% of the ventilation grille may be covered (e.g. by cable ducts)!
- Maintain the following installation distances: 40 mm at the top, 20 mm at the bottom and 5 mm on the left and right are recommended if the device continuously runs at more than 50% of the rated output. Increase this distance to 15 mm if the adjacent device is a heat source (e.g. another power supply).

3 Technical data, mounting, wiring

3.1 AC input

AC input			
AC input	Nom.	AC 100-240V	Suitable for TN, TT and IT networks with alternating voltage
AC input range	Min.	90-264Vac	Continuous operation
	Min.	264-300Vac	For up to 500 ms max.
Permissible voltage L or N to earth	Max.	300Vac	Continuous according to IEC 62477-1
Input frequency	Nom.	50-60Hz	±6%
Turn-on voltage	typ.	81Vac	Static, see Fig. <i>Input voltage range</i>
Shut-down voltage	typ.	63Vac/71Vac	At zero load / nominal load, static value, see Fig. <i>Input voltage range</i>
External input protection	See recommendations in chapter External input protection [► 28]		

AC input		AC100V	AC120V	AC230V	
Input current	typ.	2.60A	2.17A	1.18A	At 24V, 10A, see Fig. <i>Input current over output current</i>
Power factor ¹⁾	typ.	0.99	0.98	0.93	At 24V, 10A, see Fig. <i>Power factor over output current</i>
Crest factor ²⁾	typ.	1.6	1.7	2.0	At 24V, 10A
Start-up delay	typ.	360ms	260ms	200ms	See Fig. <i>Switch-on behavior definitions</i>
Rise time	typ.	60ms	60ms	60ms	At 24V, 10A constant current load, 0mF load capacity, see Fig. <i>Switch-on behavior definitions</i>
	typ.	230ms	230ms	230ms	At 24V, 10A constant current load, 10mF load capacity, see Fig. <i>Switch-on behavior definitions</i>
Turn-on overshoot	Max.	200 mV	200 mV	200 mV	See Fig. <i>Switch-on behavior definitions</i>

¹⁾ The power factor is the ratio of real (or active) power to apparent power in an AC circuit.

²⁾ The crest factor is the mathematical ratio of the peak value over the RMS value of the input current waveform.

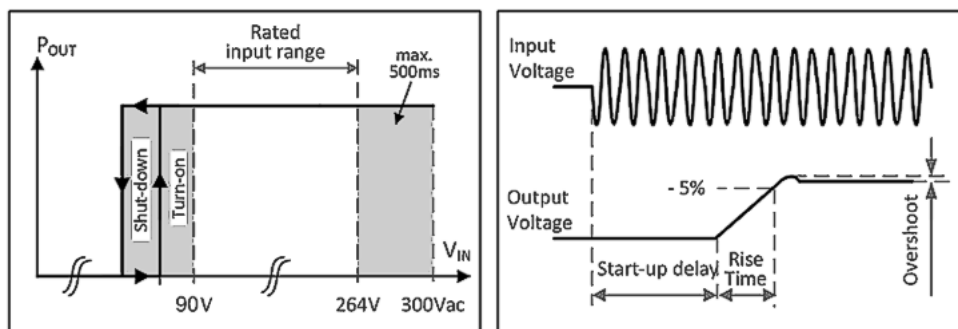

Fig. 1: Input voltage range; switch-on behavior definitions

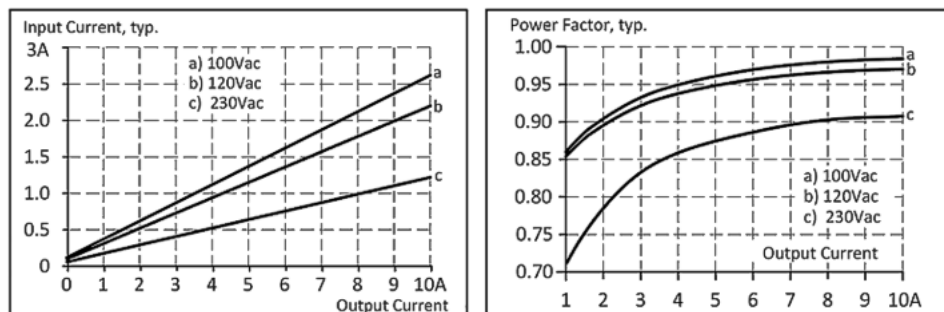

Fig. 2: Input current over output current; power factor over output current

3.2 DC input

Do not operate this power supply with DC input voltage!

3.3 Input inrush current

Active input inrush current limitation (NTCs that are bridged by a relay contact) limits the input inrush current after the input voltage is switched on.

		AC 100V	AC 120V	AC 230V	
Input inrush current ^{*)}	Max.	14.5A _{peak}	17A _{peak}	32A _{peak}	At +40°C, cold start
	typ.	7A _{peak}	8.5A _{peak}	16A _{peak}	At +25°C, cold start
	typ.	11.5A _{peak}	14A _{peak}	26A _{peak}	At +40°C, cold start
Inrush energy	Max.	0.2A ² s	0.3A ² s	1A ² s	At +40°C, cold start

^{*)} The charge current of the interference suppression capacitors during the first few microseconds after switching on is not taken into account.

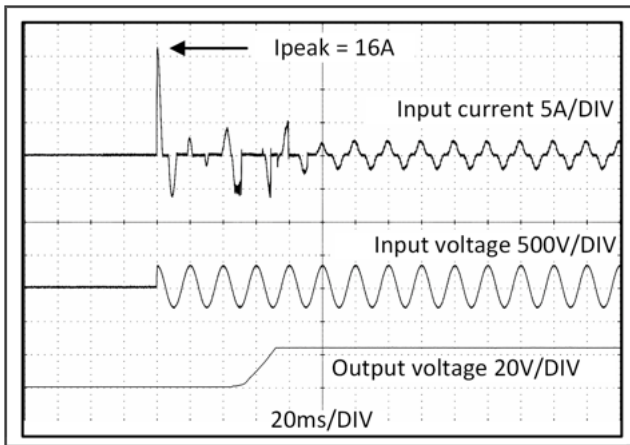

Fig. 3: Input inrush current surge, typical behavior, 230Vac input, 24V/10A output, 25°C ambient temperature

3.4 Output

Output voltage	Nom.	DC 24V	
Adjustment range	Min.	24-28V	Guaranteed value
	Max.	30V ²⁾	In end position of the potentiometer, clockwise.
Factory settings	typ.	24.1V	±0.2%, at full load (cold device)
Line regulation	Max.	5 mV	Between 90 and 264Vac
Load regulation	Max.	100 mV	Between 0 and 10A, static value, see Fig. <i>Output voltage over output current, typ.</i>
Residual ripple and ripple voltage	Max.	100mVpp	Bandwidth 20 Hz to 20 MHz, 50 Ohm
Output current	Nom.	10A	At 24V and an ambient temperature below 55°C, see Fig. <i>Output current over ambient temperature</i>
	Nom.	6.25A	At 24V and an ambient temperature below 70°C, see Fig. <i>Output voltage over output current, typ.</i>
	Nom.	8.6A	At 28V and an ambient temperature below 55°C, see Fig. <i>Output current over ambient temperature</i>
	Nom.	5.4A	At 28V and an ambient temperature below 70°C, see Fig. <i>Output voltage over output current, typ.</i>
Output power	Nom.	240W	Ambient temperature below 55°C
	Nom.	150W	Ambient temperature below 70°C
Overload characteristics		Continuous current	Output voltage > 13Vdc, see Fig. <i>Output voltage over output current, typ.</i>
		Hiccup mode ¹⁾	Output voltage < 13Vdc, see Fig. <i>Output voltage over output current, typ.</i>
Short circuit current	Min.	11A	Load impedance 50mOhm, see Fig. <i>Output voltage over output current, typ.</i> The discharge current of the output capacitors is not included.
	Max.	15A	Load impedance 50mOhm, see Fig. <i>Output voltage over output current, typ.</i> The discharge current of the output capacitors is not included.
	typ.	4.8A	Average current (rms), load impedance 50mOhm, see Fig. <i>Output voltage over output current, typ.</i>
Output capacity	typ.	2,850µF	Included in the power supply

¹⁾ **Hiccup mode**

In case of severe overload (when the output voltage drops below 13V) the power supply delivers a continuous output current for 2-5 seconds. The output is then switched off for approx. 1 second before a new start attempt is automatically made for 1 second. This cycle is repeated as long as the overload exists. The device starts operating normally again once the overload has been rectified.

²⁾ This is the maximum output voltage that can occur in the end position of the potentiometer in clockwise direction due to tolerances. It is not a guaranteed value that can be achieved. A typical value is 28.5V.

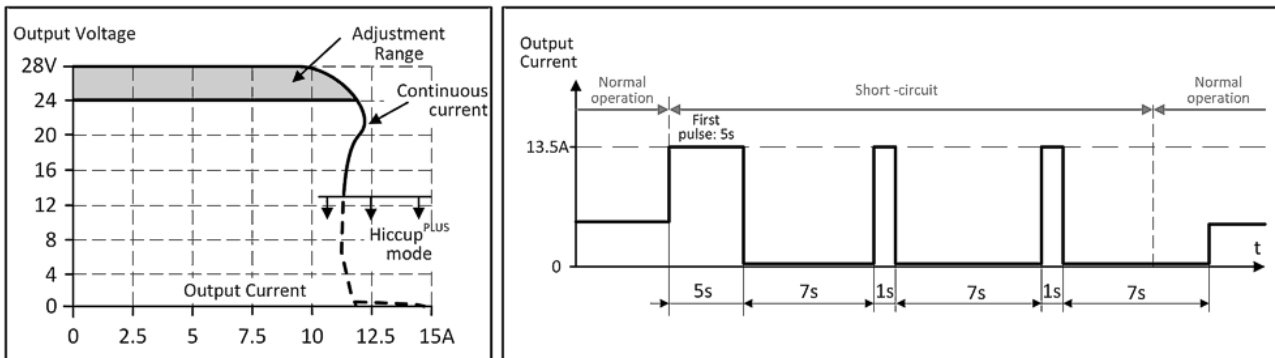

Fig. 4: Output voltage over output current, typ.; short circuit at output, hiccup mode

3.5 Hold-up time

		AC 100V	AC 120V	AC 230V	
Hold-up time	typ.	65ms	65ms	65ms	At 24V, 5A, see Fig. <i>Hold-up time over input voltage</i>
	Min.	53ms	53ms	53ms	At 24V, 5A, see Fig. <i>Hold-up time over input voltage</i>
	typ.	32ms	32ms	32ms	At 24V, 10A, see Fig. <i>Hold-up time over input voltage</i>
	Min.	26ms	26ms	26ms	At 24V, 10A, see Fig. <i>Hold-up time over input voltage</i>

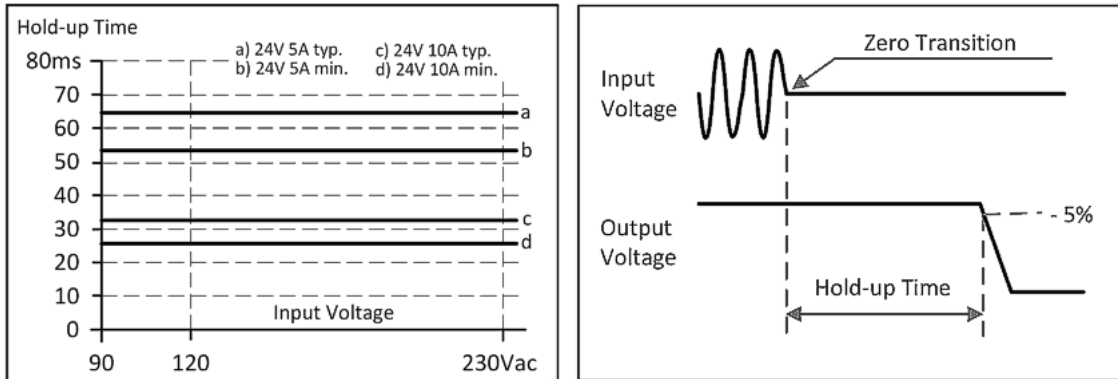

Fig. 5: Hold-up time over input voltage; switch-off behavior, definitions

3.6 DC-OK relay contact

This feature monitors the output voltage at the output terminals of an active power supply.

Threshold voltage	typ. 21.8V (fixed)
The contact closes	When the output voltage reaches 21.8V.
The contact opens	When the output voltage falls below 21.7V.
Contact load capacity	Maximum 60Vdc 0.3A, 30Vdc 1A, 30Vac 0.5A, ohmic load
	Minimum permissible load: 1mA at 5Vdc
Insulation voltage	See the dielectric strength table in the chapter on Safety features [▶ 23]

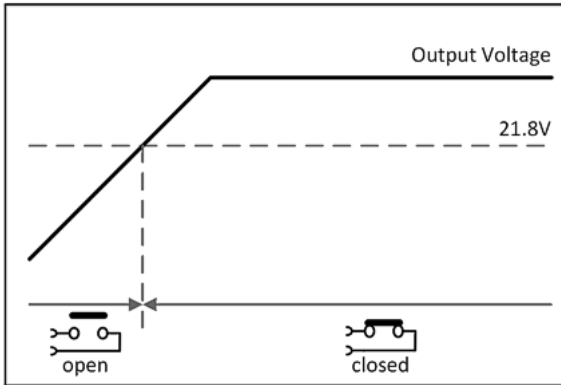

Fig. 6: Behavior of the DC-OK relay contact

3.7 Efficiency and losses

		AC 100V	AC 120V	AC 230V	
Efficiency	typ.	93.2%	94.0%	95.2%	At 24V, 10A, full load
Average efficiency ^{*)}	typ.	92.7%	93.1%	93.9%	25% at 2.5A, 25% at 5A, 25% at 7.5A. 25% at 10A
Losses	typ.	4.0W	4.0W	3.4W	At 24V, 0A (no load)
	typ.	9.0W	8.5W	7.5W	At 24V, 5A (half load)
	typ.	17.5W	15.3W	12.1W	At 24V, 10A (full load)

^{*)} The average efficiency is based on assumptions for a typical application with the power supply unit operating at 25% of the nominal load during 25% of the time, 50% of the nominal load during 25% of the time, 75% of the nominal load during 25% of the time and 100% of the nominal load during the remaining time.

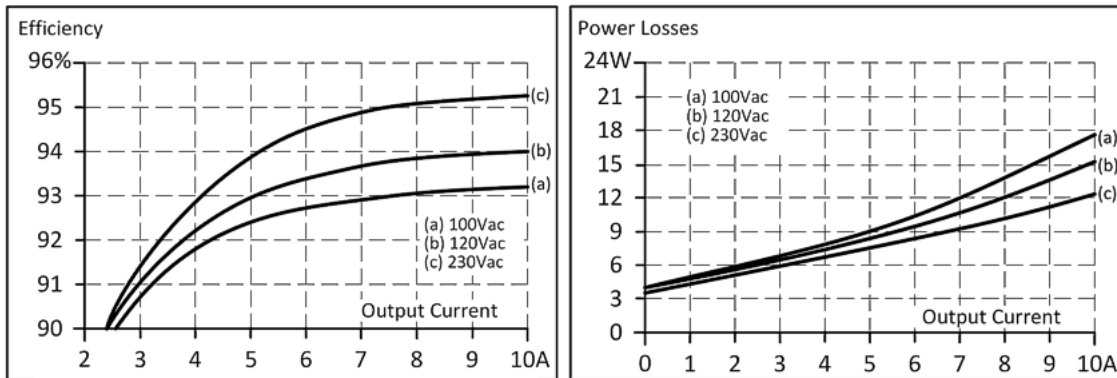

Fig. 7: Efficiency over output current; losses over output current

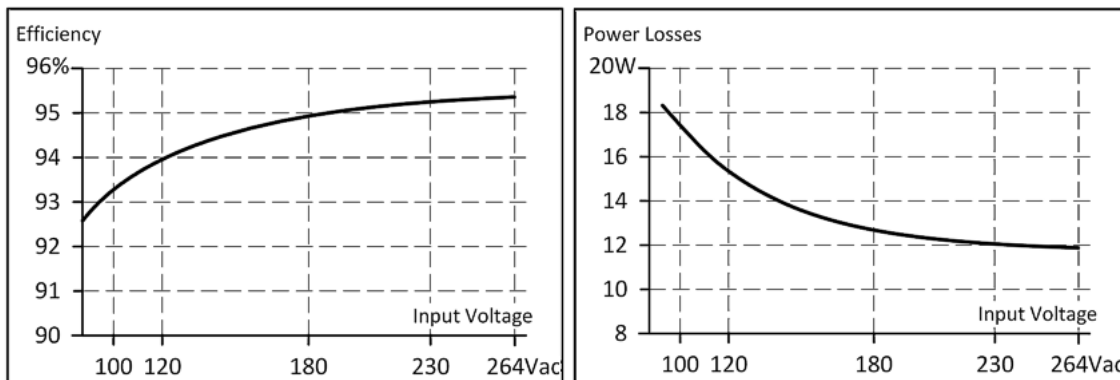

Fig. 8: Efficiency over input voltage; losses over input voltage

3.8 Lifetime expectancy and MTBF

The lifetime expectancy shown in the table indicates the minimum number of operating hours (service life) and is determined by the lifetime expectancy of the built-in electrolytic capacitors. The lifetime expectancy is stated in operating hours and is calculated according to the specifications of the capacitor manufacturer.

The manufacturer of the electrolytic capacitors only guarantees a maximum life of up to 15 years (131,400h). Any number exceeding this value represents a calculated theoretical lifetime which can be used to compare devices.

	AC 100V	AC 120V	AC 230V	
Lifetime expectancy	89,000h	93,000h	103,000h	At 24V, 5A and +40°C
	252,000h	262,000h	291,000h	At 24V, 5A and +25°C
	47,000h	55,000h	74,000h	At 24V, 10A and +40°C
	133,000h	156,000h	209,000h	At 24V, 10A and +25°C

MTBF stands for **Mean Time Between Failure**, which is calculated from the statistical failure rate of the components and indicates the reliability of a device. It is a statistical representation of the probability of equipment failure and does not necessarily represent the service life of a product.

The MTBF number is a statistical representation of the probability of equipment failure. An MTBF number of 1,000,000h, for example, means that statistically, if there are 10,000 devices in use, one device will fail every 100 hours. However, it is not possible to say whether the failed device has been in operation for 50,000 hours or only 100 hours.

	AC 100V	AC 120V	AC 230V	
MTBF SN 29500, IEC 61709	655,000h	736,000h	822,000h	At 24V, 10A and 40°C
	1,149,000h	1,267,000h	1,391,000h	At 24V, 10A and +25°C
MTBF MIL HDBK 217F	323,000h	345,000h	374,000h	At 24V, 10A and 40°C; Ground Benign GB40
	441,000h	471,000h	508,000h	At 24V, 10A and 25°C; Ground Benign GB25
	72,000h	78,000h	85,000h	At 24V, 10A and 40°C; Ground Fixed GF40
	94,000h	101,000h	111,000h	At 24V, 10A and 25°C; Ground Fixed GF25

3.9 Terminals and wiring

The terminals are designed to be finger-safe according to IP20 and are suitable for field or factory wiring.

Technical data	Input	Output	DC-OK signal
Connection cross-section	e*: max. 6mm ² f*: max. 4mm ² a*: max. 4mm ² (d<2.8mm)	e*: max. 6mm ² f*: max. 4mm ² a*: max 4mm ² (d<2.8mm)	e*: max. 1.5mm ² f*: max. 1.5mm ² a*: max. 1.5mm ² (d<1.6mm)
Connection cross section (AWG)	e*: AWG 20-10 f*: AWG 20-10 a* AWG 20-10 (d<2.8mm)	e*: AWG 20-10 f*: AWG 20-10 a* AWG 20-10 (d<2.8mm)	e*: AWG 28-16 f*: AWG 28-16 a*: AWG 28-16 (d<1.6 mm)
Strip length	7mm / 0.28inch	7mm / 0.28inch	7mm / 0.28inch

e* = solid wire
f* = stranded wire
a* = with ferrule

Instructions

- Use suitable copper cables that are designed for a minimum operating temperature of:
 - 75°C for ambient temperatures up to 55°C and
 - 90°C for ambient temperatures up to at least 70°C.
- Observe national installation rules and regulations!
- Make sure all individual wires of a strand enter the terminal connection!
- Do not use the device without PE connection.
- Unused terminal spaces should be tightened securely.
- Ferrules are permissible.

3.10 Functional wiring diagram

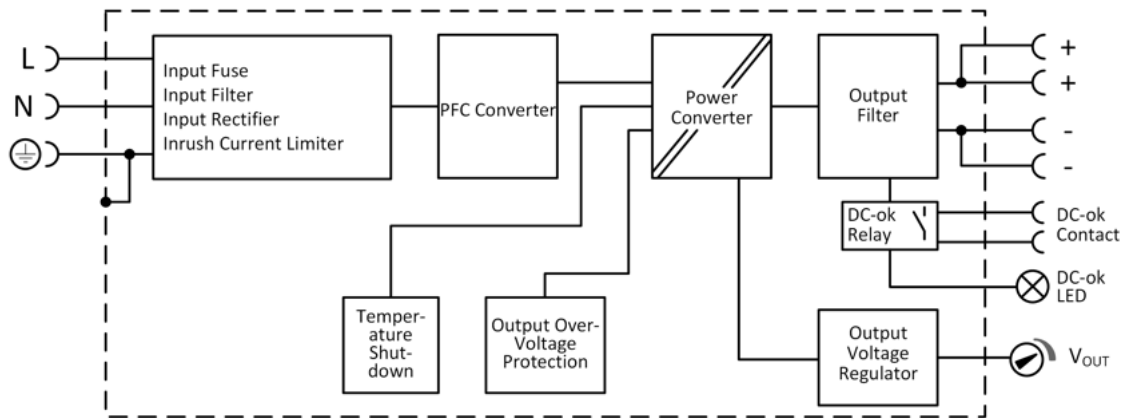

Fig. 9: Functional wiring diagram

3.11 Front side and operating elements

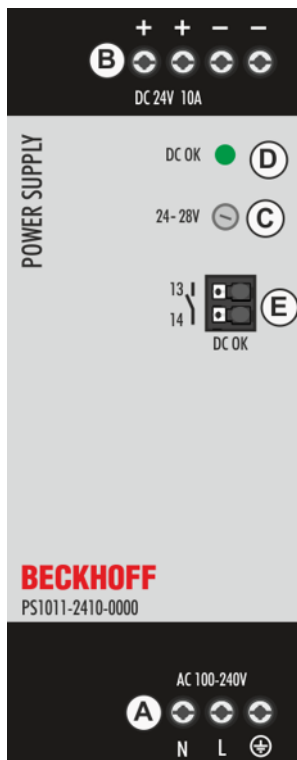



Fig. 10: Front PS1011-2410-0000

Input terminals (screw terminals)

Designation (A)	Description
N	Mains input N
L	Mains input L
	Protective conductor, PE

Output terminals (screw terminals)

Designation (B)	Description
+	two identical positive poles, positive output
-	two identical negative poles, negative output

Potentiometer for the output voltage

Designation (C)	Description
Potentiometer	Guaranteed adjustment range: 24-28V Factory setting: 24.1 V

DC-OK LED

Designation (D)	Description
LED green	Lights up when the output voltage is above 18V.

DC-OK relay contact (push-in terminals)

Designation (E)	Description
Terminals 13 / 14	See chapter DC-OK relay contact [▶ 15] for details.

3.12 EMC

The power supply is suitable for application in industrial environments as well as in residential, commercial and light industrial areas and small businesses.

EMC interference immunity			
Strong transients	VDE 0160	Over the entire load range	750V, 0.3ms

EMC interference emission	According to generic standards: EN 61000-6-4	
Conducted interference emission, input lines	EN 55011, EN 55015, EN 55022, FCC Part 15, CISPR 11, CISPR 22	Class B
Conducted interference emission, output lines ¹⁾	IEC/CISPR 16-1-2, IEC/CISPR 16-2-1	Limit values for the DC power connection according to EN 61000-6-3 not met
Interference emission	EN 55011, EN 55022	Class B
Harmonic input current	EN 61000-3-2	Met, class A limits
Voltage fluctuations, flicker	EN 61000-3-3	Met, tested with non-pulsating constant current loads.

This device complies with FCC Part 15.

Operation is subject to the following two conditions: (1) This device may not cause harmful interference, and (2) this device must be able to deal with any interference received, including interference that may cause undesired operation.

¹⁾ for information only, not mandatory for EN 61000-6-3

Switching frequencies		
PFC converter	60kHz to 140kHz	Input load and output voltage dependent
Main converter	65kHz to 150kHz	Output voltage and output load dependent

3.13 Environment

Environment		
Operating temperature ¹⁾	-25°C to +70°C	Reduction of the output power according to Fig. <i>Output current over ambient temperature</i>
Storage temperature	-40°C to +85°C	For storage and transport
Output load reduction	6W/°C	Between +55°C and +70°C
Humidity ²⁾	5 to 95% r.h.	According to IEC 60068-2-30
Oscillation, sinusoidal ³⁾	2–17.8Hz: ±1.6mm; 17.8-500Hz: 2g 2 hours/axis	According to IEC 60068-2-6
Impacts ³⁾	30g 6ms, 20g 11ms 3 impacts/ direction, 18 impacts in total	According to IEC 60068-2-27
Installation altitude	0 to 2000m	Without restrictions
	2000 to 6000m	Reduce output power or ambient temperature, see Fig. <i>Output current over installation altitude</i> IEC 62477-1, overvoltage category II
Load reduction due to installation altitude	15W/1000m or 5°C/1000m	Above 2000m, see Fig. <i>Output current over installation altitude</i>
Overvoltage category	III	According to IEC 62477-1, for altitudes up to 5000m
	II	Altitudes from 2000m to 6000m
Degree of pollution	2	According to IEC 62477-1, non-conductive
LABS-free	The device does not release any silicones or other paint-wetting impairment substances and is suitable for use in paint shops.	

¹⁾ The working temperature is identical to the room temperature or the ambient temperature and is defined as the air temperature 2cm below the device.

²⁾ Do not energize when condensation is present

³⁾ Tested in conjunction with DIN rails according to EN 60715 with a height of 15mm and a thickness of 1.3mm and standard mounting position.

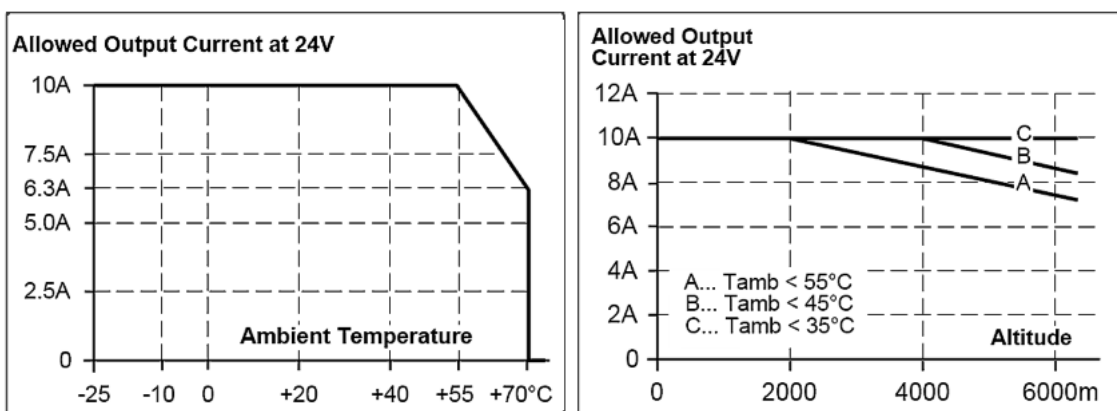

Fig. 11: Output current over ambient temperature; output current over installation altitude

3.14 Protective functions and safety features

Protective functions		
Output protection	Electronically protected against overload, no load and short circuit. Audible noises may occur in the event of a protection event.	
Output overvoltage protection	Typ. 30.5Vdc Max. 32Vdc	In the event of an internal power supply fault, a redundant circuit limits the maximum output voltage. The output switches off and automatically tries to switch on again.
Protection class	IP 20	According to EN/IEC 60529 Caution: For use in a controlled environment in accordance with CSA 22.2 No. 107.1-01.
Overtemperature protection	yes	Output shutdown with automatic restart.
Protection against input transients	MOV (metal oxide varistor)	For further information see EMC chapter [▶ 21]
Input fuse	yes	Fuse cannot be replaced by the user.

Safety features		
Input/output isolation	SELV	IEC/EN 60950-1
	PELV double or reinforced insulation	IEC/EN 60204-1, IEC 62477-1, IEC 60364-4-41
Protection class	I	A PE connection (protective earth) is required.
Insulation resistance	> 5MΩ	Input over output, 500Vdc
Touch current (leakage current)	typ. 0.30mA / 0.79mA	At 100Vac, 50Hz, TN, TT / IT network
	typ. 0.42mA / 1.1mA	At 120Vac, 60Hz, TN, TT / IT network
	typ. 0.67mA / 1.7mA	At 230Vac, 50Hz, TN, TT / IT network
	max. 0.37mA / 0.94mA	At 110Vac, 50Hz, TN, TT / IT network
	max. 0.54mA / 1.33mA	At 132Vac, 60Hz, TN, TT / IT network
	max. 0.88mA / 2.18mA	At 264Vac, 50Hz, TN, TT / IT network

3.15 Dielectric strength

The output voltage is earth-free and has no ohmic connection to earth.

Type and component tests are carried out by the manufacturer. Field tests can be performed in the field using suitable test equipment that ramps up the voltage with a slow ramp (2s rising and 2s falling). Connect all input terminals and all output poles to each other before performing the tests. During the test, set the cut-off current to the value shown in the table below.

To meet the PELV requirements according to EN60204-1 section 6.4.1, we recommend that either the positive pole, the negative pole or any other part of the output circuit is connected to the protective earthing system. This helps to avoid situations where a load starts unexpectedly or cannot be disconnected if an unnoticed earth leakage occurs.

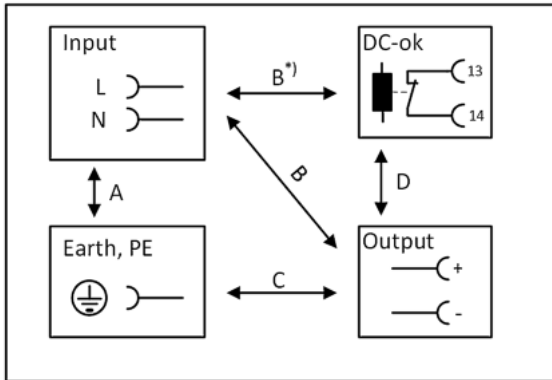

Fig. 12: Dielectric strength

B^{*)} When checking the input to DC-OK, make sure that the maximum voltage between DC-OK and the output is not exceeded (column D). We recommend connecting the DC-OK pins and the output pins when performing the test.

		A	B	C	D
Type test	60s	2500Vac	3000Vac	1000Vac	500Vac
Component test	5s	2500Vac	2500Vac	500Vac	500Vac
Field test	5s	2000Vac	2000Vac	500Vac	500Vac
Setting the cut-off current		> 15mA	> 15mA	> 20mA	> 1mA

3.16 Declaration of conformity and approvals

	<p>EU declaration of conformity</p>
	<p>UK Declaration of Conformity Trade conformity assessment for England, Scotland and Wales The UKCA mark indicates conformity with the UK Statutory Instruments 2016 No. 1101 (LVD) 2016 No. 1091 (EMC) and 2012 No. 3032 (RoHS)</p>
	<p>Registration for the Eurasian Customs Union market (Russia, Kazakhstan and Belarus)</p>
	<p>UL Certificate: UL 61010-1/2-201 Applicable for US and Canada</p>

3.17 Dimensions and weight

Dimensions and weight	
Overall width	49mm
Height	124mm
Depth	124mm The height of the DIN rails must be added to the depth of the device to calculate the total installation depth required
DIN rail	Use 35 mm DIN rails according to EN 60715 or EN 50022 with a height of 7.5 or 15mm.
Weight	540g
Plastic material of the housing	Flame retardant polycarbonate (PC) - UL94-V0 Vicat softening temperature specified at 149°C according to ASTM D1525
Installation clearances	See chapter on Safety instructions and installation requirements [► 9]

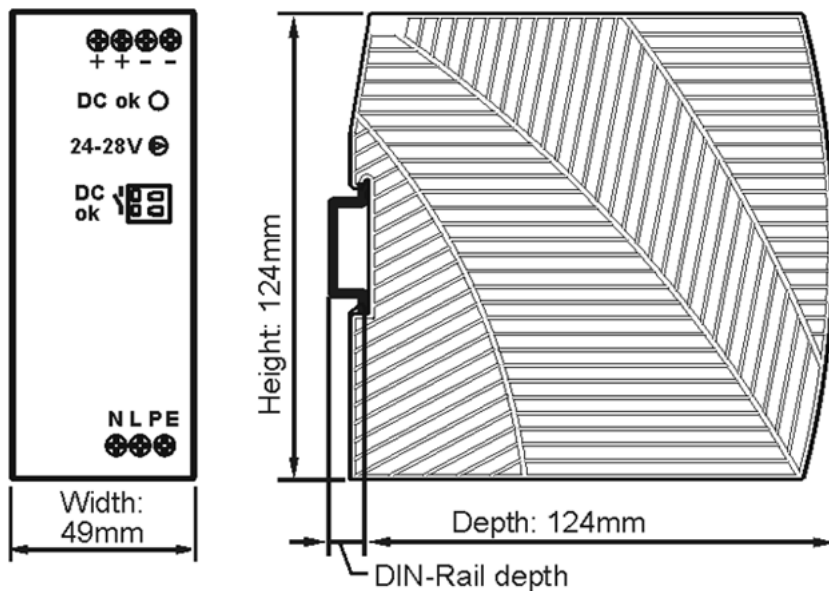

Fig. 13: Front/side view PS2001-2410-0000

4 Application notes

4.1 Peak current capability

The device can deliver peak currents (for up to several milliseconds) that are higher than the specified short-term currents.

This helps when starting loads with high current intensity. Magnetic coils, contactors and pneumatic modules often have a stationary coil and a pick-up coil. The input inrush current requirement of the pick-up coil is several times higher than the steady-state current and usually exceeds the rated output current. The situation is exactly the same when starting a capacitive load.

The peak current capability also ensures safe operation of downstream circuit breakers of load circuits. The load circuits are often individually fused with circuit breakers or fuses. In the event of a short circuit or overload in a circuit, the fuse or circuit breaker needs a certain amount of overcurrent to open in time. This prevents a voltage drop in adjacent circuits.

The additional current (peak current) is supplied by the power converter and the built-in large-size output capacitors of the power supply. The capacitors are discharged during such an event, which leads to a voltage drop at the output. The following two examples show typical voltage drops for ohmic loads:

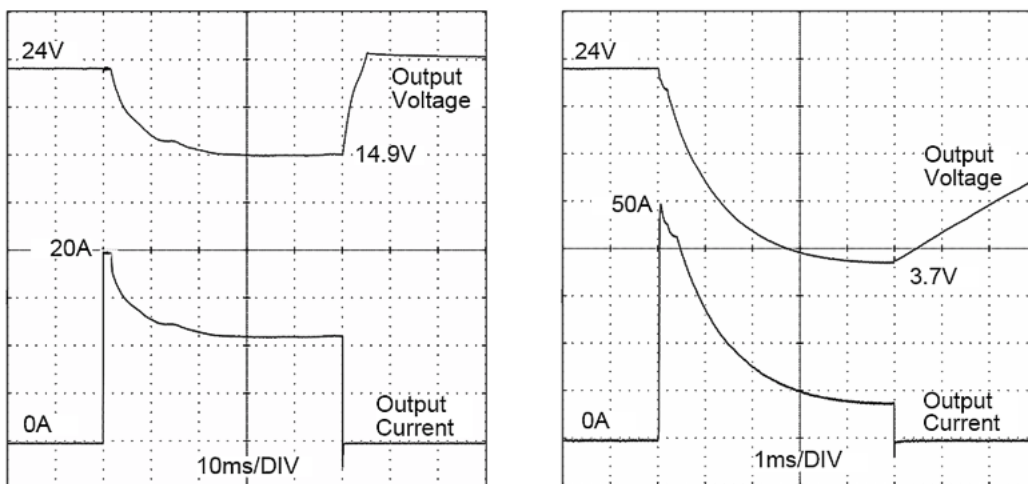

Fig. 14:
 20A peak load (ohmic load) for 50ms output voltage drops from 24V to 14.9V;
 50A peak load (ohmic load) for 5ms output voltage drops from 24V to 3.7V

Peak current voltage drops	
Typically from 24V to 14.9V	At 20A for 50ms, ohmic load
Typically from 24V to 7.1V	At 50A for 2ms, ohmic load
Typically from 24V to 3.7V	At 50A for 5ms, ohmic load

4.2 Back-feeding loads

Loads such as braking motors or inductors can feed back voltage to the power supply. This feature is also known as back EMF. (**E**lectro **M**agnetic **F**orce).

This power supply is stable and will not malfunction if a load is feeding back voltage to the power supply. It is irrelevant whether the power supply is switched on or off.

The maximum permissible feed-back voltage is 35Vdc. The absorbing energy can be calculated according to the large built-in output capacitor indicated in the [output data](#) [► 13].

4.3 External input protection

The device is tested and approved for circuits that are fused up to 30A (UL) and 32A (IEC). External protection is only required if the supply line has a protection that is higher than this.

Also check the local regulations and requirements. Local regulations may apply in some countries.

If an external fuse is required or used, minimum requirements must be taken into account to avoid false tripping of the circuit breaker. A circuit breaker with a minimum value of 10A with B characteristic or 6A with C characteristic should be used.

4.4 Parallel use to increase power

Do not connect devices for higher output currents in parallel.

4.5 Parallel use for 1+1 redundancy

It is possible to connect power supplies in parallel for redundancy operation in order to achieve better system availability. Redundant systems provide a certain amount of additional power to operate the load when a power supply unit fails. The simplest method is to connect two power supplies in parallel. This is called 1+1 redundancy. If one power supply fails, the other can automatically supply the load current without interruption.

The 1+1 redundancy allows ambient temperatures up to +70°C.

i Notes on parallel use for 1+1 redundancy

- Be sure to use a redundancy module in order to decouple devices from one another. This prevents the defective device from becoming a load for the other device and the output voltage no longer being maintainable.
- Note that leakage current, EMI, input inrush current and harmonics increase when using multiple devices.

Recommendations for the construction of redundant power supply systems:

- Power supplies that contain a DC-OK signal contact are best suited for the construction of redundant power supply systems.
 - Use this DC-OK signal contact to monitor the individual power supplies.
- Use separate grids for each power supply whenever possible.
- It is recommended to set the output voltages of all devices to the same value (± 100 mV) or to leave them at the factory setting.

Wiring example:

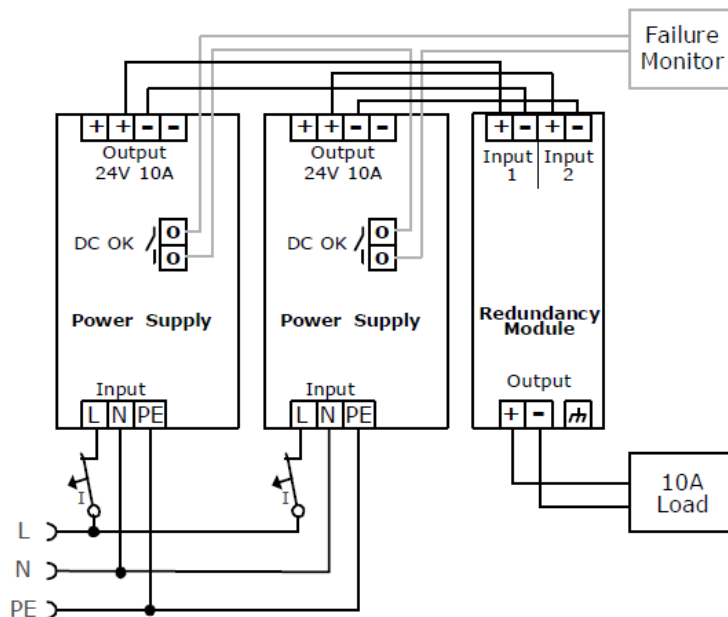

Fig. 15: Wiring for 1+1 redundancy with a PS9401-2440-0000 redundancy module

4.6 Series connection

Power supplies of the same type can be connected in series to increase the output voltages. As many devices can be connected in series as necessary, as long as the sum of the output voltages does not exceed 150Vdc. Voltages with a potential above 60Vdc are no longer defined as safety extra-low voltage (SELV) and can be dangerous. Such voltages must be protected with a contact hazard protection.

Grounding of the output is required if the sum of the output voltage exceeds 60Vdc.

Avoid application of return voltage (e.g., from a braking motor or battery) to the output terminals.

Keep an mounting distance of 15 mm (left / right) between two power supplies and avoid installing the power supplies on top of each other.

Remember that leakage current, electromagnetic interference, input inrush current and harmonics increase when using multiple power supplies.

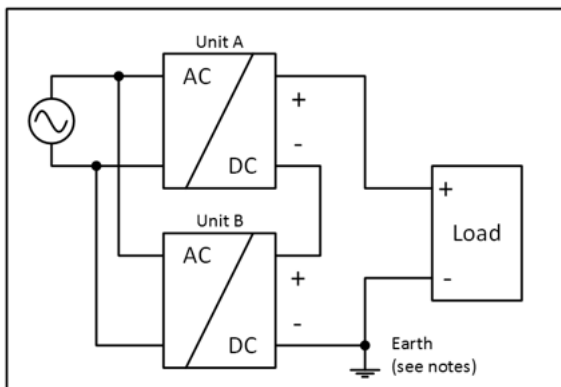

Fig. 16: Series connection

4.7 Inductive and capacitive loads

The device is designed to supply all load types, including capacitive and inductive loads. If very large capacitors such as EDLCs (electric double-layer capacitors or "UltraCaps") with a capacitance of more than 2.0 F are connected to the output, the device charges the capacitor in hiccup mode if necessary (see [Output \[13\]](#) chapter).

4.8 Charging batteries

Do not use the power supply to charge batteries.

4.9 Operation on two phases

The power supply can also be used on two phases of a three-phase system. Such a phase-to-phase connection is permissible as long as the supply voltage is below $240V+10\%$.

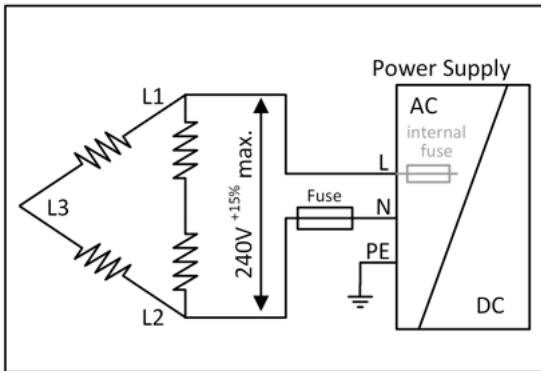

Fig. 17: Operation on two phases

Make sure that the conductor connected to the N terminal is appropriately fused.

4.10 Use in a tightly sealed enclosure

When the power supply is installed in a tightly sealed enclosure, the temperature inside the housing is higher than outside. In this case, the temperature inside the housing is considered the ambient temperature for the power supply.

The power supply is positioned at the center of the housing. There are no other heat-generating elements in the housing

The temperature sensor in the housing is positioned at the center on the right side of the power supply with a distance of 1cm.

The following measurement results can be used as reference for estimating the temperature rise inside the housing.

	Case A	Case B
Housing size	180x180x165mm Rittal housing, protection class IP66 PK 9519 100, plastic	180x180x165mm Rittal housing, protection class IP66 PK 9519 100, plastic
Input voltage	230Vac	230Vac
Load	24V, 8A; (=80%)	24V, 10A; (=100%)
Temperature inside the housing	43.7°C	48,6°C
Temperature outside the housing	24.9°C	24.9°C
Temperature increase	18.8K	23.7K

5 Disposal



Products marked with a crossed-out wheeled bin shall not be discarded with the normal waste stream. The device is considered as waste electrical and electronic equipment. The national regulations for the disposal of waste electrical and electronic equipment must be observed.

6 Appendix

6.1 Accessories

Power supply	Accessories		
	Redundancy module	Buffer module	UPS component
PS1011-2410-0000	PS9401-2420-0000	PS9011-2420-0001	CU8130-0xxx

PS9401-2420-0000 – Redundancy Module



The PS9401-2420-0000 is a redundancy module that can be used to construct 1+1 and N+1 redundant systems.

It has two input channels, to which power supplies with an output current of up to 12 A can be connected, and an output that can carry nominal currents up to 20 A. The output can also be operated with up to 24 A if the ambient temperature is < +45°C.

The redundancy module uses MOSFET technology instead of diodes for decoupling the two input channels. This reduces the heat development and the voltage drop between input and output. Due to the low power loss, the device is very narrow and requires a width of just 32 mm on the DIN rail.

Large connection terminals enable secure and fast installation. The redundancy module requires no additional auxiliary voltage.

Due to the international approvals package, the device is suitable for virtually every application.

Observe the connection instructions in the chapter "[Parallel use for redundancy](#)"!

PS9011-2420-0001 – Buffer Module



The PS9011-2420-0001 buffer module is an additional device for 24 V DC power supply units. It supplies power to bridge typical mains power failures or extends the hold-up time after switching off the AC voltage.

If the power supply unit supplies sufficient voltage, the buffer module stores energy in the integrated electrolytic capacitors. In the event of a failure of the mains voltage, the stored energy is supplied to the DC bus in a controlled process.

The buffer module can be connected at any point in parallel with the load circuit and does not require any control wiring.

A buffer module can provide 20 A of additional power and can be added in parallel to increase the output current or hold-up time.

The PS9011-2440-0000 buffer module can optionally be used to achieve longer hold-up times.

CU8130-0xxx – UPS component



CU8130-0xxxx are battery-backed, uninterruptible power supplies (UPS). If the external 24 V DC input voltage is lost, the UPS takes over the supply of the devices connected to it thanks to its regulated and buffered 24 V DC output voltage.

The CU81xx UPS series is suitable for all Beckhoff components, particularly Industrial PCs, Embedded PCs, Panels and Panel PCs.

The main features of this UPS are:

- battery module based on NiMH cells
- mounting of the UPS on the DIN rail or on the rear panel of the control cabinet
- protocol-based communication with the Industrial PC either via OCT (**O**ne **C**able **T**echnology) or USB
- digital signals for communication with non-protocol-capable end devices
- TwinCAT PLC function blocks for querying the UPS operation

A special feature of the Beckhoff CU81xx devices is OCT (**O**ne **C**able **T**echnology) as communication technology between UPS and Industrial PC. This means that the two connecting lines (+24 V, 0 V) between Industrial PC and UPS are used not only to supply the Industrial PC, but also for bidirectional data transmission.

If both sides are OCT-capable, no further connection, e.g., via USB, is required.

Further information on UPS components can be found on the Beckhoff [homepage](#).

6.2 Documentation issue status

Version	Comment
1.1	<ul style="list-style-type: none">- Chapter "Parallel operation for 1+1 redundancy" added- Chapter "Accessories" added- Update structure
1.0	<ul style="list-style-type: none">- First public issue- Addenda & corrections
0.1	<ul style="list-style-type: none">- Preliminary documentation for PS1011-2410-0000

6.3 Support and Service

Beckhoff and their partners around the world offer comprehensive support and service, making available fast and competent assistance with all questions related to Beckhoff products and system solutions.

Beckhoff's branch offices and representatives

Please contact your Beckhoff branch office or representative for local support and service on Beckhoff products!

The addresses of Beckhoff's branch offices and representatives round the world can be found on her internet pages: www.beckhoff.com

You will also find further documentation for Beckhoff components there.

Support

The Beckhoff Support offers you comprehensive technical assistance, helping you not only with the application of individual Beckhoff products, but also with other, wide-ranging services:

- support
- design, programming and commissioning of complex automation systems
- and extensive training program for Beckhoff system components

Hotline: +49 5246 963 157
e-mail: support@beckhoff.com
web: www.beckhoff.com/support

Service

The Beckhoff Service Center supports you in all matters of after-sales service:

- on-site service
- repair service
- spare parts service
- hotline service

Hotline: +49 5246 963 460
e-mail: service@beckhoff.com
web: www.beckhoff.com/service

Headquarters Germany

Beckhoff Automation GmbH & Co. KG

Hülshorstweg 20
33415 Verl
Germany

Phone: +49 5246 963 0
e-mail: info@beckhoff.com
web: www.beckhoff.com

More Information:

www.beckhoff.com/ps1011-2410-0000

Beckhoff Automation GmbH & Co. KG
Hülshorstweg 20
33415 Verl
Germany
Phone: +49 5246 9630
info@beckhoff.com
www.beckhoff.com

