

Montageanleitung B17 Hybrid

konfektionierbares Kupplungsgehäuse mit Crimpanschluss, axial,
5x1,5mm² + 4xAWG22, ECP: Powerstift / Datenstift

Stückliste

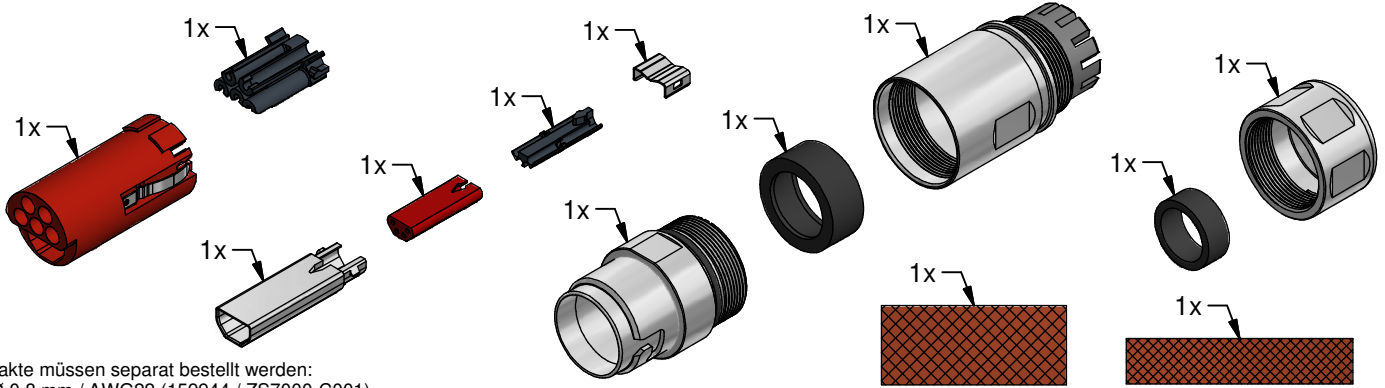

Kontakte müssen separat bestellt werden:
4 x Ø 0,8 mm / AWG22 (159944 / ZS7000-C001)
5 x Ø 1,5 mm / 1,5 mm² (159951 / ZS7000-C005)

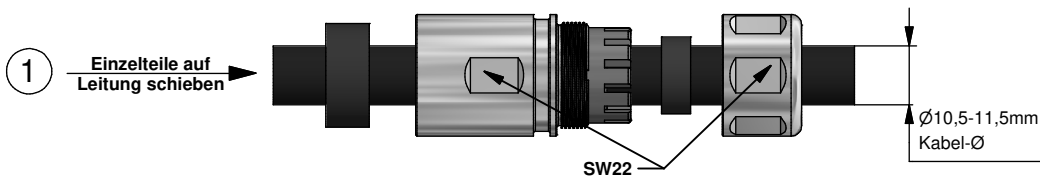

Laufrichtung beachten!

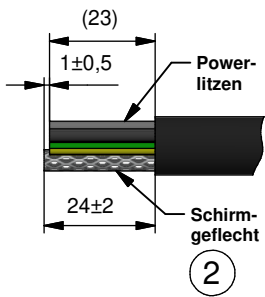

Füllstoffe bündig mit Kabelmantel wegschneiden!

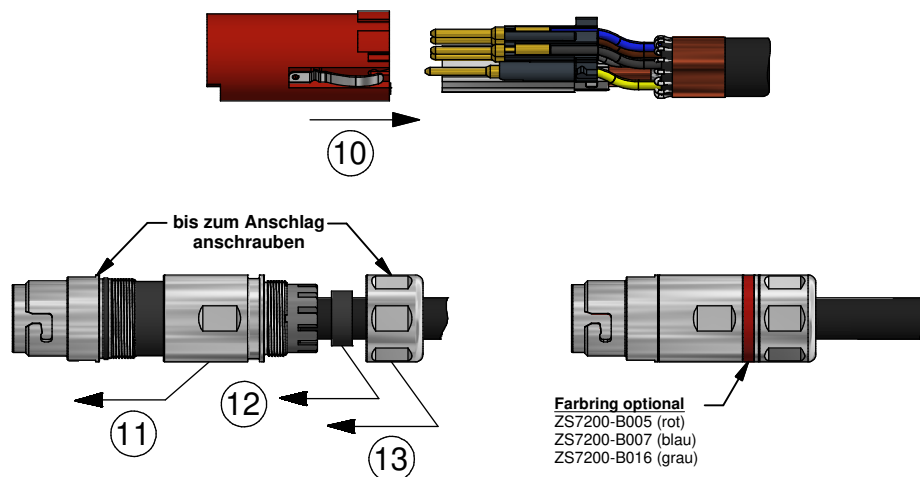
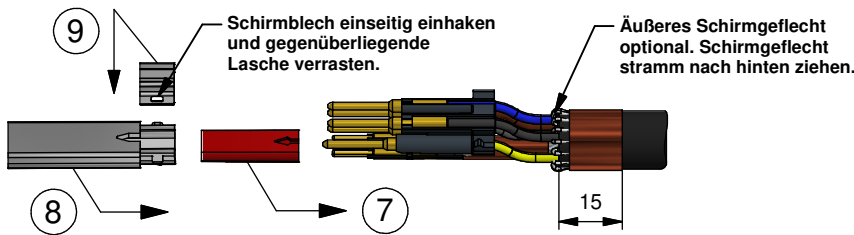
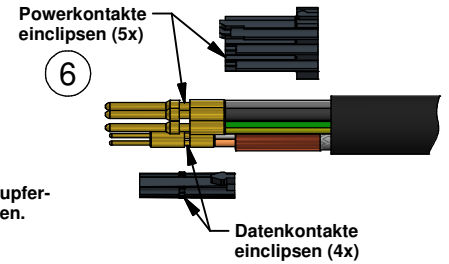
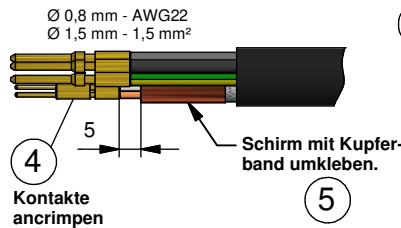
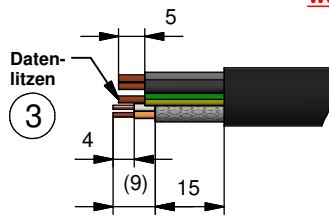

Achtung: Ansicht von Kabelausgang dargestellt! Auf richtige Farbwahl achten!

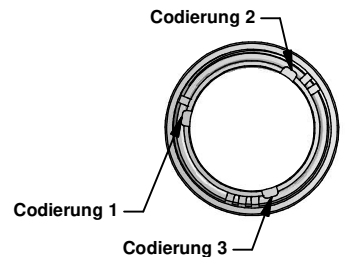
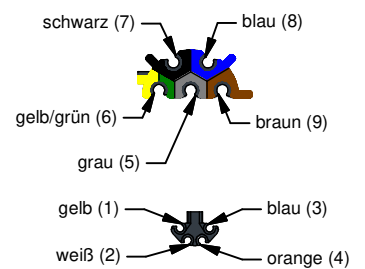

Nur eine Codierung montierbar!

Werkzeug / Zubehör

Crimpzange	Crimpeinsatz / Locator
ZB8810-0000	ZB8810-0001

Beckhoff®, TwinCAT®, EtherCAT®, EtherCAT P®, Safety over EtherCAT®, TwinSAFE®, XFC® und XTS® sind eingetragene und lizenzierte Marken der Beckhoff Automation GmbH.
Die Verwendung anderer in dieser Dokumentation enthaltenen Marken oder Kennzeichen durch Dritte kann zu einer Verletzung von Rechten der Inhaber der entsprechenden Kennzeichen führen.

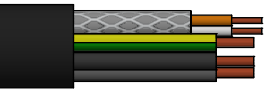

Assembly instruction B17 hybrid

field attachable coupling housing with crimp connection, axial,
 5x1.5mm² + 4xAWG22, ECP: power (male) / data (male)

parts list

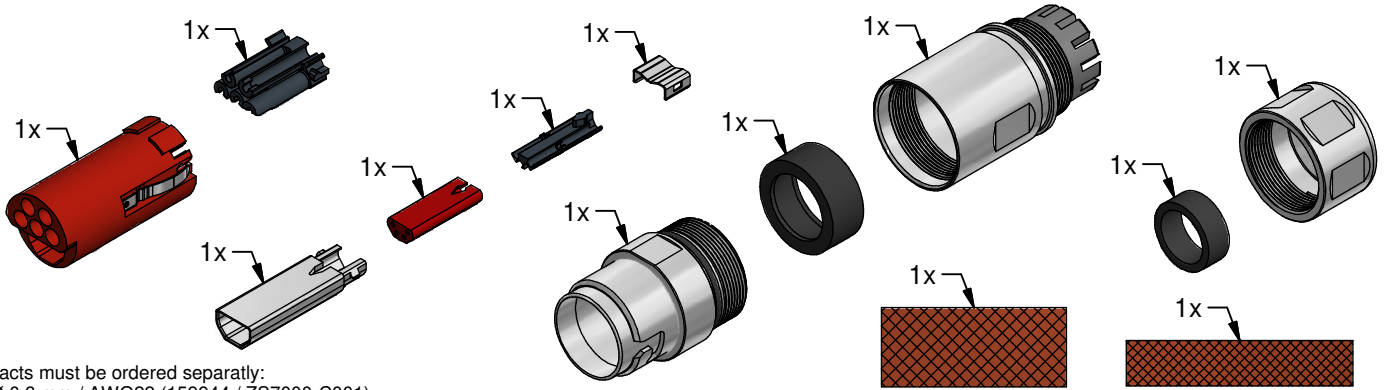

Contacts must be ordered separately:
 4 x Ø 0.8 mm / AWG22 (159944 / ZS7000-C001)
 5 x Ø 1.5 mm / 1.5 mm² (159951 / ZS7000-C005)

Please consider the cable direction!

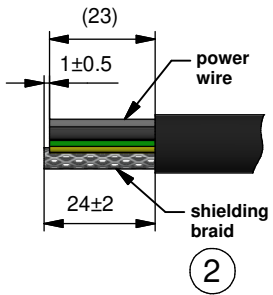
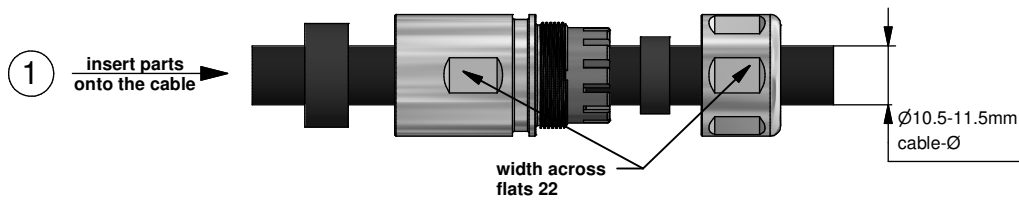

Cut off the fillers!

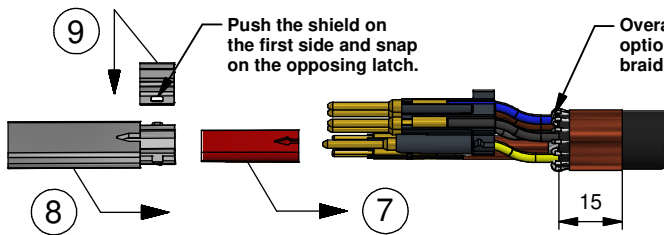
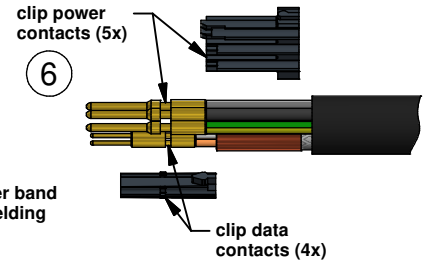
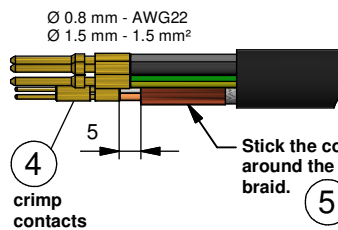
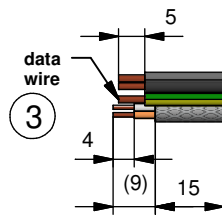

Overall shielding braid optional. Pull the shielding braid tightly backwards.

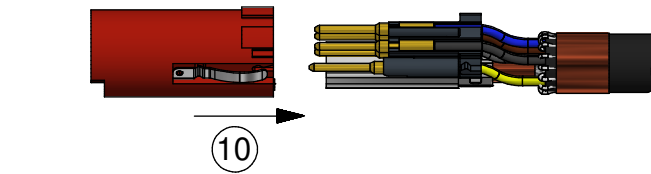

Attention: View from cable outlet!
 Consider the right choice of colors!

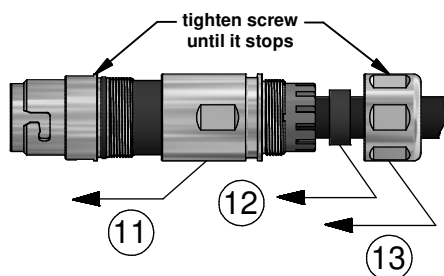
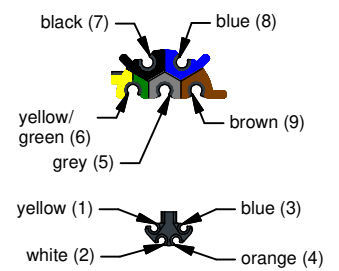

color ring optional
 ZS7200-B005 (red)
 ZS7200-B007 (blue)
 ZS7200-B016 (grey)

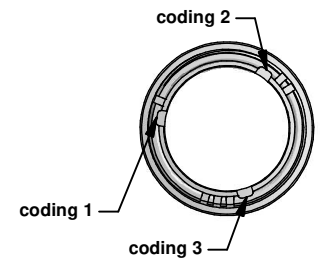

Only one coding mountable!

Beckhoff®, TwinCAT®, EtherCAT®, EtherCAT P®, Safety over EtherCAT®, TwinSAFE®, XFC® and XTS® are registered trademarks of and licensed by Beckhoff Automation GmbH. Other designations used in this publication may be trademarks whose use by third parties for their own purposes could violate the rights of the owners.

© Beckhoff Automation GmbH & Co. KG 08/2016

The information provided in this brochure contains merely general descriptions or characteristics of performance which in case of actual application do not always apply as described or which may change as a result of further development of the products. An obligation to provide the respective characteristics shall only exist if expressly agreed in the terms of contract.

tools / accessory parts

crimping tool	crimping insert / locator
ZB8810-0000	ZB8810-0001

BECKHOFF

790-954400 / 7901A167 Rev. a
 Beckhoff art.-no.: ZS7200 - 0010