

# **Beckhoff** Drive Technology

## **Designing your Application with AL2000**

Last change: 08.11.2001

**BECKHOFF**



# Contents

## Designing your Application with AL2000

<b>1. Introduction</b>	<b>5</b>
<b>2. System considerations</b>	<b>6</b>
Power Supply	6
Protective Earth	7
Heat dissipation	8
Mounting frame: solidity and stability	9
Positioning	10
Measurement unit	11
Servo-controller	12
Accuracy	13
Braking	14
Contamination	15
Cables	16
Bearings	17
Vertical applications	18
Coupling of Coil Units	19
<b>3. Linear motor dimensioning</b>	<b>20</b>
Introduction	20
Physical background	21
Used symbols	22
Used formulas	23
The case	25
Dimensioning force and speed	26
Step 1: Worst case cycle	26
Step 2: Kinematic analysis	28
Step 3: Force analysis	29
Step 4: Motor sizing	30
Step 5: Amplifier sizing	31
<b>4. Appendix</b>	<b>32</b>
Heat transfer and temperature	32
Influences of accuracy	34
<b>5. Technical data</b>	<b>35</b>
List of specifications AL series	35

<b>Peak force - velocity diagrams</b>	<b>36</b>
<b>DC link diagram</b>	<b>38</b>
<b>Technical data of some optical linear rulers</b>	<b>39</b>

# 1. Introduction

With the series AL2000 Beckhoff Industrie Elektronik introduced a wide, standard range of high quality linear motors. Due to a far-reaching standardization it is possible for designers to select the linear motors themselves. However specialized knowledge is required for making the right design decisions. This knowledge is provided here step by step departing from a practical case.

A linear motor of Beckhoff Industrie Elektronik is not a system in itself. Usually a linear motor is build within a total machine concept or a working unit. Depending on the application choices have to be made concerning the specifications and the sizing of the motorsystem. To assure a faultless operation all the components of the motorsystem must comply to strict requirements. In this document the relevant choices and requirements are discussed step by step.

Several stages can be distinguished in a motor system analysis and design proces. In this leaflet you will be guided through these stages. First of all some system considerations have to be made. These considerations will provide you with relevant practical information, for instance about the powersupply, heat dissipation, stability, accuracy and braking. As a designer of linear motor systems one should be familiar with some theoretical physical laws and formulas. This information will be provided together with the step by step analysis and design proces. Special attention is given to mechanics.

This leaflet is the second of a series of three, concerning Beckhoff Industrie Elektronik AL2000 series Linear Motors. The series consists of the following titles:

1. A Primer of Linear Motors
2. Designing your Application with AL2000 series Linear Motors
3. Installing AL2000 series Linear Motors

## 2. System considerations

### Power Supply

The performance of a linear motor is depending on the powersupply. Therefore a linear motor is specified for an appropriate voltage. The motor's servo-amplifier can be connected to different voltage power supplies: 230 to 480V, one- or three phase. By means of capacitors and a rectifier bridge the power is transformed in a DC voltage link. For high forces and velocities a DC link is required of at least 560 V. For limited forces and velocities a 310 V DC link will do. For more information about the DC voltage link and the powersupply - motorforce relation, please see the appendix - 'Peak force - velocity diagrams' and - 'DC Link diagram'

## Protective Earth (PE)

To prevent hazardous situations in case of an electrical failure, all metal components must be earthed. The coilunit housing and ironcore are earthened by the PE of the motor's power cable. The cable shield is connected to the housing but is not appropriate as PE. Earthen the cable shield on the servo-amplifier to prevent EMC problems. Follow instructions of the servo-amplifier.

The magnet plates which are bolted to the frame, have to be electrically connected to the frame through the bolts. The stainless cover of the magnetplate is earthened through the magnetplates. The earthing has to be checked according to demands with respect to electrical machine safety.

## Heat dissipation

Heat dissipation is a very important but difficult item. Every linear motor produces heat. The heat will mainly be dissipated in the coil unit. There are two aspects to consider:

1. This heat must flow away to ambient. If possible, the route of the heat conduction should be traced.
2. Heat generation causes temperature differences. That can be unacceptable for accuracy or other reasons. For your system, especially for the coil unit, the allowed temperature increase should be determined.

The coil unit is fitted with a temperature sensor. In some designs the coil unit is not capable enough of transferring the heat to the surrounding air. This counts especially for heavy loaded motors with a high ratio between motorforce and coil unit size. Also when the motor is thermally isolated or when ventilation is prevented by a hood. In these cases active cooling, like water cooling, is needed.

Without cooling an unacceptable heat up of the coil unit could occur. This could result in lower performance, thermic safety stops and even damage to your motor system. Water-cooling of the motor is very effective to reduce the heatflow and to obtain a constant temperature of the body. Water-cooling requires a water conditioning unit containing at least a pump and a cooler. Beware of leaking. The temperature sensor can be used to detect failures of a watercooling system. An additional flow-sensor for controlling the cooling is strictly not necessary, but yields extra safety and system information. If heat up of particular parts of the system is critical, a thermal insulation between the coil unit and the critical parts of the slide can be considered. This can reduce, but not nullify, the temperature rise. Sometimes small heat up also takes place in the magnet plates.

## Mounting frame: solidity and stability

The propelling forces of a linear motor are relatively high. Therefore the frame needs sufficient dynamic stiffness. Because of the required accuracy the frame should be insensible to shocks and vibrations.

A linear motor system gains its accuracy by means of a high bandwidth feedback control loop. In this loop all mechanical parts such as load, frame and mountings are involved as well as the characteristics of the servo-controller and the linear encoder. The loop can be compromised by the characteristics of the construction. A bad construction can even cause total loss of control of the linear motor system.

Attention should be paid to the machine's natural frequencies. Especially vibrations between 50 - 500 Hz in driving direction can be harmful for accuracy. To meet main problems a rule of thumb is: the motorsystem should be rigidly connected to a massive and rigid body of at least 3 times the mass of the accelerated load.

## Positioning

LM applications require a sophisticated position and velocity feedback. A linear encoder and a servocontroller are taken up in the positioning system. The position of the slide is detected by a measurement unit, a ruler-probe combination. The unit's linear encoder returns the information to the servocontroller. The accuracy of the motor system depends strongly on this positioning system.

Most measurement units return incremental position information. So the linear motor has to do without the absolute position of the slide. Especially when starting a motor operation this could be problematical. Herefore the slide is activated to some minimal testmovement. This 'magnetic alignment' supplies the positioning system with the required information.

## Measurement unit

The series AL2000 motors use a wireless linear encoder for communication, speed and position control. The performance of the linear motor depends on the characteristics of the applied linear encoder. The use of an encoder system with a wire is not possible due to the bad dynamic characteristics. The unit is to be connected and shielded with care. Any disturbance of the positioning signal could lead to positioning failures and system oscillations.

Several types of measurement units can be applied, such as encoder kits by Heidenhain, Renishaw, Siko and Numerik Jena. Mostly the resolution should lie between 0.1 and 5  $\mu\text{m}$ . The accuracy of the measurement unit must at least be better than the required accuracy of the motor system. Depending on the dynamics of the application it can be a factor 2 to 10.

The position of a moving body is measured with respect to the frame. Depending on its stiffness the frame acts more or less as a reaction force body. In the measurement appearing rotations or vibrations should be disregarded. Therefore the mounting of the measurement unit is critical. The probe should be mounted as close as possible to the mass centre of the complete moving unit (slide + load), whereas the ruler needs to be placed near the centroid of the frame. The presence of rotations or vibrations is surmountable but their measurement and feed back should be avoided.

In exceptional cases stick or slip effects are present. If so the measurement can be placed best between the bodies between that cause these effects.

## Servo-controller

The position information as well as the current in the coils is fed back to a servocontroller. Here the information is processed and translated into a proper input signal for the linear motor. Because the linear motor needs a powerful input the signal is provided by a servo-amplifier.

The slide's movement is directed by a three phase voltage pulse to the coil unit. The phase depends on the actual and the desired position of the slide. Hereby the motion's directing quantity is the pulse width. In fact the servo-amplifier is a pulse width modulation amplifier with a fixed voltage and a fixed switching frequency.

AL2000 linear motors can ideally be combined with our servo-controller series AX2000. With prepared motor-, feedback- and thermal protection cables we offer a complete and flexible linear motor system.

## Accuracy

Generally the accuracy of the motor system is influenced by

- the accuracy of the error detection and positioning system,
- the static stiffness of the system,
- the dynamic stiffness of the system

The main restriction for the accuracy arises from the lack of stability of the mounting frame, as discussed before. Here we discuss the restrictions of the linear motor system.

The linear motor itself is an electromagnetic device. It deals with resistance and selfinductance. This implies that the current in the coils always lags behind the provided voltage signal. Since the magnetic force is directly linked to the current this means that the motorforce also lags behind.

With a static load (constant velocity) the positioning error will be small. Static disturbance arises from cogging at stand-still or friction. Only a constant force has to be compensated. The system must react with an appropriate constant force to the disturbance. Generally this is done by an integrator action of the position controller. This action takes some settling time. The more accurate the positioning, the higher the settling time. An accurate positioning typically requires a settling time of 5 to 25 ms.

With a dynamic load (accelerating or decelerating) the system shouldn't just react appropriately but also rapidly. Now the disturbance is dynamic. It arises from cogging during move, acceleration forces, vibrations and contact forces (for instance when milling). Depending on the stiffness of the whole system the accuracy can deteriorate because of this. As a motor system can be considered as a kind of mass-spring system, it is obvious that the accuracy is worsened most by disturbances at the system's natural frequency.

By the servo controller the returned information of the position, the velocity and the current is processed and translated into an appropriate voltage signal to the linear motor. The controller has to deal with some delay because of processor and update times. For a schematic overview, see the appendix 'Influences on accuracy'.

The voltage signal to the linear motor is provided as pulses with a fixed switching frequency. Here the pulse width is the parameter to be regulated. Accuracy is limited by the fixed pulse frequency and the fixed pulse voltage.

Needless to say that the accuracy of the positioning system also depends on the accuracy of the linear encoder and the thermal stability of the system's components.

## Braking

A controlled stop by the servocontroller is recommended, especially with short runouts. The Servocontroller stops the motor as quick as possible using the maximum force of the motor. This action has to be activated by a signal from the position controlling system. Herefore power up is required. In addition there should be no error status in the servocontroller.

Usually a linear motor's braking depends on the power supply and position information. Without additive measurements this could result in an uncontrolled rollout to the end of the track in case of power loss or measurement and controlling errors. All active solutions need to be activated by the loss of power or control. This means that a normal, free motion of the slide is only made possible by one or more unlocked or unbolted braking systems. Suitable is the use of relais.

Risky situations by uncontrolled roll out can be prevented in several ways, such as

1. The use of pneumatic rail guide brakes. This establishes a short runout. Some rail guide suppliers offer brakes that are released by air pressure. These can be very useful for vertical applications and for some safety situations.
2. Short-circuiting of the motor coils. This results in a moderate runout. A braking force is generated when the coils are short circuited. There are standard relais for this action. The braking energy is dissipated in the coil unit. Requirements for relay: current similar to  $I_{peak}$ , contact resistance below 0.5 Ohms, switching time according to application requirements.
3. The use of mechanical end stops. Mechanical end stops check the slide at the end of the track. So there is a maximum run out. Non-flexible end stops are not suitable. Hydraulic or pneumatic dampers absorb the energy of the movement and stop the slide. Springs cause the slide to be returned, but can be combined with damping by short circuiting. Requirements: no damage/danger by uncontrolled movement possible
4. a combination of the mentioned measurements.

Which methods are useful depends on the application. For design, consider at least the following worst case situations:

- Safety violation detected by sensors (linear motor must stop immediatly).
- Programming error, (uncontrolled movement at maximum speed).
- Overtemperature in motor, (linear notor must stop within seconds).
- Fatal error in the Servocontroller (uncontrolled movement).
- Main Power loss (loss of motor control and force).
- DC control Power loss (loss of motor control and force).
- Failure of end of track detector, (hitting end of track).
- Air pressure loss.

## Contamination

As a standard Beckhoff Industrie Elektronik offers a stainless steel cover that can be placed over the magnet plates. Objects falling on the cover might get jammed causing damage to the system. Particularly small metal parts such as bolts residing on the cover can be quite harmful.

## Cables

Linear motors have moving cables. In case of watercooling the coolant lines move as well. Take care of mechanical support of the cables and lines. Make moving parts replaceable.

## Bearings

To assure a free movement the slide should be provided with robust bearings that run smoothly on two rails. The rails are mounted aside the magnetplate. This construction ensures the right airgap between the coil unit and the magnet plate. For the sideward positioning of the coil unit to the magnetplates a small tolerance is acceptable.

The coil unit contains iron parts which are strongly attracted by the permanent magnets of the magnet plate whether or not the motor is electrically propelled. This attraction force should continuously be beared by the linear bearings. Therefore it is important to take the attraction force into account when dimensioning the bearings.

## Vertical applications

Linear motors in vertical applications often require a counterbalance mechanism to prevent dropping the load in the event of power interruption. The counterbalance neutralizes the gravitational force, making an additional continuous force of the linear motor superfluous. The inertia of the motorsystem though could increase. For counterbalance mechanisms can be thought of springs, pneumatic cylinders or counterweights.

When the moving mass is small, especially when the gravitational force is significantly smaller than the continuous attraction force, the application could do without a counterbalance mechanism.

## Coupling of Coil Units

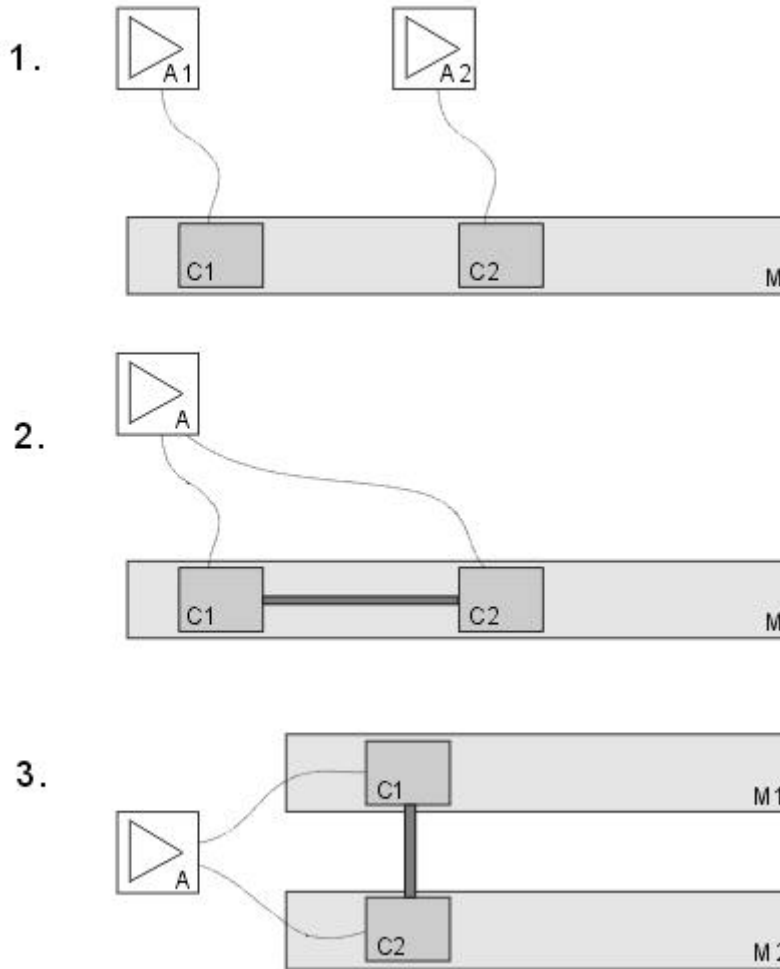

A magnettrack can be shared by more than one slide. A servocontroller can be shared as well. The following combinations can be distinguished (see figure).

1. Two (or more) coil units share a magnettrack, each of them directed by its own amplifier.
2. Two coil units are coupled (rigidly connected), sharing one amplifier and one magnettrack.
3. Two coil units are coupled, sharing one amplifier. They are running on different parallel tracks.

When two linear motors share one amplifier, they are connected in parallel. For motor sizing objectives the currents of both motors should be added up. It is not possible to mount motors in series. Use one of the temperature sensors. Use the sensor of the coil unit which is expected to have the worst cooling and also to reach the highest temperature.

## 3. Linear motor dimensioning

### Introduction

The choice for the right linear motor size depends on the requirements of your positioning application, especially the worst case requirements. These requirements can be modelled and translated in some characteristic parameters, such as time, maximum speed, mass of load, inertia and friction. By means of a kinematic and force analysis these parameters can be linked to typical motor parameters, like peak force and continuous force. On base of the calculated values an appropriate motor size is to be selected. In addition the appropriate servo-amplifier can be chosen.

Below a case is worked out as a kind of finger exercise. Understanding this case requires basic knowledge of some physical laws and principles, especially kinematics and dynamics.

## Physical background

Usually a linear motor's motion can be distinguished in 3 stages:

1. acceleration
2. constant (or maximum) velocity
3. deceleration

Below this is represented in a velocity-time diagram.

### Velocity-time diagram for a combined or ' long motion'

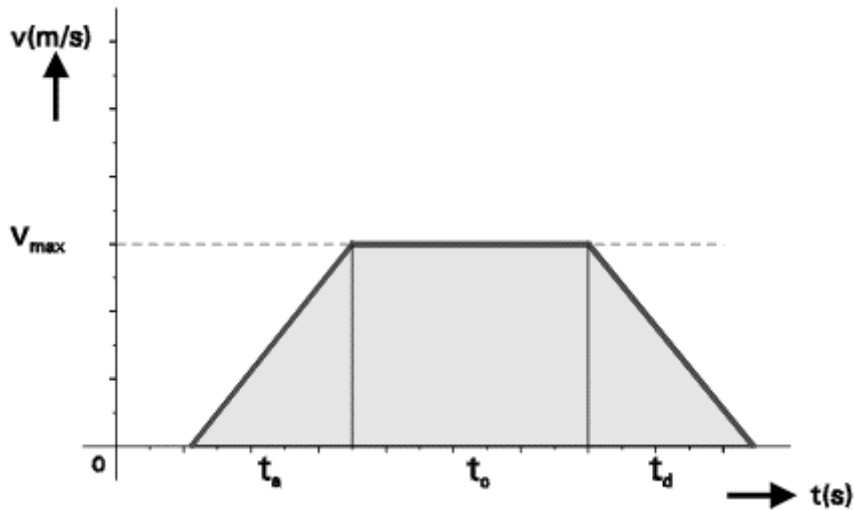

During  $t_a$  the acceleration takes place and during  $t_c$  the velocity is constant at its maximum. The deceleration to stand still takes place in  $t_d$ . The total distance covered by the motion equals the area under the graphical drawing.

During acceleration and deceleration the largest forces are displayed while the movement at constant speed only requires the force needed to overcome friction. A linear motor that is constantly moving to and fro without reaching its maximum velocity is thus loaded upmost. In the diagram below this situation is sketched.

### Velocity-time diagram for a combined or ' short motion'

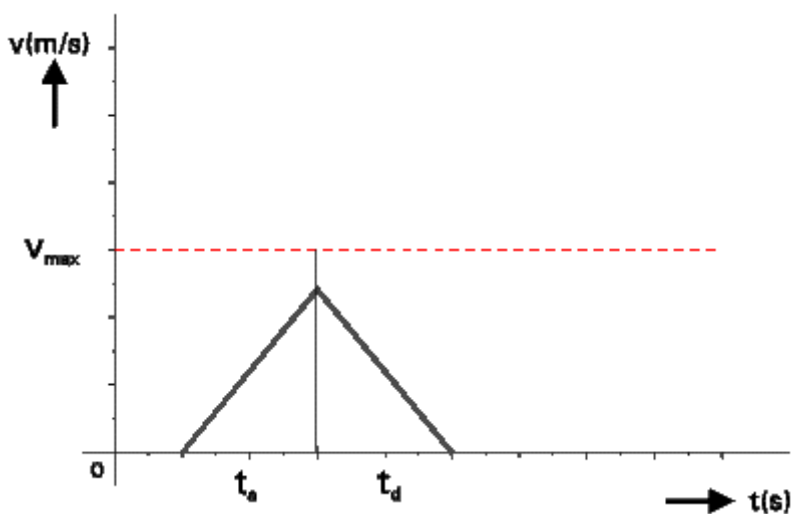

## Used symbols

symbol	unit	description
t	s	time
$t_a, t_d, t_{ad}$		time needed for acceleration, deceleration or both
$t_c$		time needed to cover a distance at constant speed
Dt		small time difference
T		total time
v	m/s	velocity
$v_a$		velocity after acceleration from stand still
$v_{max}$		maximum velocity
a	m/s <sup>2</sup>	acceleration
x	m	distance
$x_a, x_d, x_c$		distance covered by acceleration, deceleration or constant speed
X		total distance of a combined movement ( $t_a + t_c + t_d$ )
F	N	force
$F_a, F_d, F_{ad}$		force needed for acceleration and/or deceleration
$F_l$		force applied by the load (like processing contact forces)
$F_{peak}$		motor's peak force
$F_{cont}$		motor's continuous force
$F_f$		friction force
$F_{rms}$		mean force over a longer period (root mean square)
M	kg	mass of the load
Q	W	dissipated power
$S_{25}$	N <sup>2</sup> /W	motor constant (slope) at 25°C
$S_{TW}$		motor constant at working temperature
K	N/A	motor force constant
$K_{rms}$		mean motor force constant (depending on the current)
I	A	current
$I_{peak}$		motor's peak current
$I_{cont}$		motor's continuous current
$R_{th}$	°C/W	thermal resistance
$T_w$	°C	working temperature

## Used formulas

### Kinematics

$$v_a = a \cdot t_a$$

$$x_{a,d} = \frac{1}{2} a \cdot t_{a,d}^2$$

$$x_c = v_{\max} \cdot t_c \quad \Rightarrow \quad t_c = \frac{x_c}{v_{\max}} = \frac{X - x_a - x_d}{v_{\max}}$$

From these formulas two practical estimations can be derived.

1. Estimated time of a 'short motion' when  $v_{\max}$  is not reached (see 'Velocity-time diagram for a 'short motion'):

$$t_{ad} = \sqrt{\left(4 \cdot \frac{x_{ad}}{a}\right)}$$

2. Estimated time of a 'long motion' when  $v_{\max}$  is reached (see 'Velocity-time diagram for a combined or 'long motion'):

$$t_{acd} = \frac{X}{v_{\max}} + \frac{v_{\max}}{a}$$

### Dynamics

$$F_{a,d} = M \cdot a$$

$$\overline{F}_l = \overline{F}_{a,d} + \overline{F}_f$$

$$F_{a,d} = 0 \quad \Rightarrow \quad (F_l = F_f)$$

$$F_{rms} = \sqrt{\frac{\sum_i (\Delta t_i \cdot F_{fi}^2)}{T}} = \sqrt{\frac{\sum_i (\Delta t_1 \cdot F_{f1}^2 + \Delta t_2 \cdot F_{f2}^2 + \Delta t_3 \cdot F_{f3}^2 + \dots)}{T}}$$

3. Once you know the mass of the load and having chosen a linear motor type, an estimation of the acceleration can be made by

$$a \approx \frac{3}{4} \cdot \frac{F_{peak}}{M}$$

## Other Formulas

The dissipated power by the linear motor:

$$Q = 1,3 \cdot \frac{F_{rms}^2}{S_{25}}$$

The mean motor force constant:

$$K_{rms} = \frac{F_{rms}}{I_{cont}}$$

Estimated maximum needed current:

$$I_{peak} = 1,1 \cdot \frac{\max[F_{tot}]}{K_{rms}}$$

## The case

A gripper places components and moves to and fro continuously:  $X = 0.8$  m. The duration of a single movement of 0.8 m can ultimately be 0.4 s. On both sides of the movement 0.5 s is needed for settling and gripper action.

Other parameters are:

- The mass of the load:  $M = 20$  kg.
- Friction:  $F_f = 30$  N.
- Slide air cooled, large cooling surface.
- Accuracy approximately 0.02 mm.
- Maximum speed:  $v_{\max} = 3$  m/s

## Dimensioning force and speed

### Step 1: Worst case cycle

Look for the severest job-cycle your application meets. Worst cases happen generally in two situations. First when the motor produces a high holding force and second where the motor is accelerating and deceleration continuously (short moves) with little standstill time. Now determine the quantities during the severest job-cycle. In the case there is only one job-cycle. First let's choose the type AL2006 motor.

- Calculate the acceleration of this motor:

$$a = \frac{3}{4} \cdot \frac{F_{peak}}{M} = \frac{3}{4} \cdot \frac{400}{20} = 15 \text{ m/s}^2$$

Note: The value of  $F_{peak}$  is can be found on the AL2000 series specification sheet.

- The formula to calculate the required time to cover the distance depends on whether the linear motor reaches its maximum velocity  $v_{max}$  during the movement.
  - In the case of a short move ( $v_{max}$  not reached):

$$t_{ad} = \sqrt{\left(\frac{4x_{ad}}{a}\right)} = \sqrt{\frac{4 \cdot 0,8}{15}} = 0,462 \text{ m/s}^2$$

- In this case the velocity after  $t_a$  is:

$$v_a = \frac{a \cdot t_{ad}}{2} = \frac{15 \cdot 0,46}{2} = 3,45 \text{ m/s}$$

This calculated velocity  $v_a$  exceeds the maximum velocity required for this application ( $v_{max} = 3 \text{ m/s}$ ). It is obvious that the chosen linear motor reaches the maximum velocity somewhere during the motion. In this case we will have to calculate the required time using the formula for long moves.

$$t_{acd} = \frac{X}{v_{max}} + \frac{v_{max}}{a} = \frac{0,8}{3} + \frac{3}{15} = 0,467 \text{ (s)}$$

Notice that this calculated time exceeds the required travelling time for this application (0,4 s). Therefore a more heavy type motor like the AL2012 needs to be selected.

So let's choose the type AL2012 and repeat the calculations.

- Acceleration:

$$a = \frac{3}{4} \cdot \frac{F_{peak}}{M} = \frac{3}{4} \cdot \frac{800}{20} = 30 \text{ m/s}^2$$

- Required time using the formula for short moves ( $v_{max}$  not reached):

$$t_{ad} = \sqrt{\left(\frac{4x_{ad}}{a}\right)} = \sqrt{\frac{4 \cdot 0,8}{30}} = 0,327 \text{ s}$$

- Maximum velocity during acceleration:

$$v_a = \frac{a \cdot t_{ad}}{2} = \frac{30 \cdot 0,327}{2} = 4,899 \text{ m/s}$$

Once again this velocity exceeds  $v_{\max}$  therefore the actual velocity is to be calculated using the formula for long moves ( $v_{\max}$  reached):

$$t_{acd} = \frac{X}{v_{\max}} + \frac{v_{\max}}{a} = \frac{0,8}{3} + \frac{3}{30} = 0,367 \text{ s}$$

This time is in accordance with the requirements. So the AL2012 seems to be the right choice

## Step 2: Kinematic analysis

Sketch a velocity-time diagram for the worst case cycle of your application. Mark the acceleration and deceleration time and the maximum speed. Take 20-40ms extra settlingtime when exact positioning is required.

Case kinematic analysis:

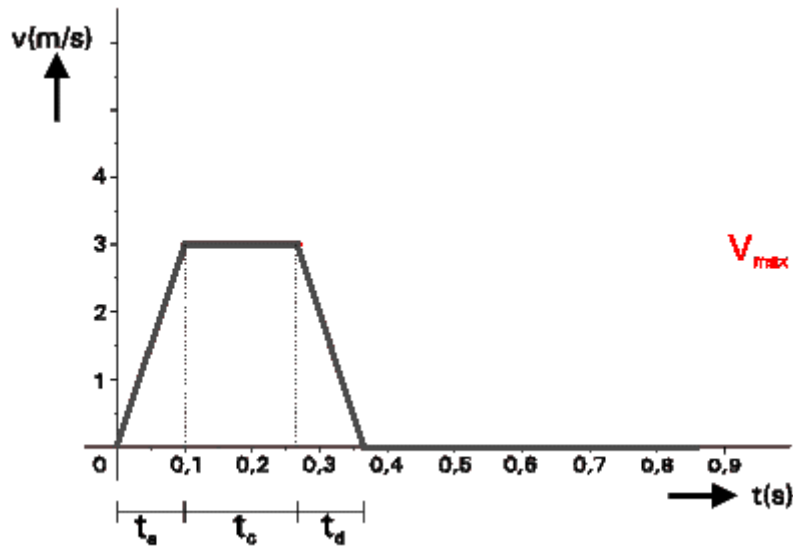

Acceleration and deceleration time and distance:

$$t_{a,d} = \frac{v_{\max}}{a} = \frac{3}{30} = 0,1 \text{ s}$$

$$x_{ad} = \frac{1}{2} a \cdot t^2 = \frac{1}{2} \cdot 30 \cdot 0,1^2 = 0,15 \text{ m}$$

In this case for acceleration and deceleration the same time and distance are needed. The time needed to cover the distance of the constant movement ( $t_c = 0,167 \text{ s}$ ) follows directly from the total time  $t_{\text{acc}}$  calculated before.

### Step 3: Force analysis

Sketch a motorforce-time diagram. The motorforce depends on:

- Required acceleration and deceleration forces.
- Friction forces.
- Processing contact forces (for instance when using bits or cutters).
- For vertical applications: the gravitational forces

The maximum force  $F_{max}$  is the overall maximum force, driving or braking. The motor's peak force should meet this. Consider the square time average force  $F_{rms}$ . This force should remain below the motor's continuous force.

Case force analysis: motorforce versus time diagram:

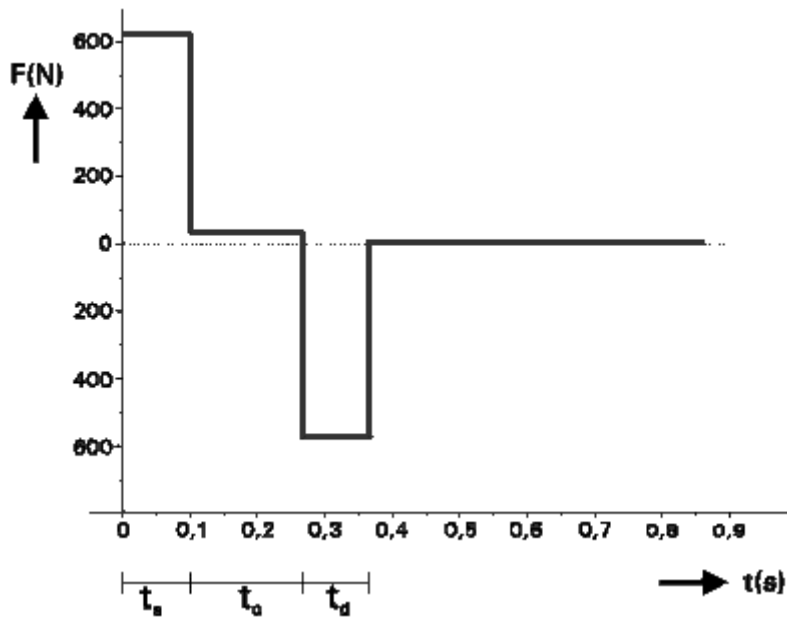

In the case we get the following results.

Parameter	Acceleration phase ( $t_a$ )	Maximum velocity phase ( $t_c$ )	Deceleration phase ( $t_d$ )	Settling and gripper action phase
Dt(s)	0,1	0,167	0,1	0,5
a(m/s <sup>2</sup> )	30	0	-30	0
F <sub>a,c,d</sub> (N)	600	0	-600	0
F <sub>f</sub> (N)	30	30	30	0
F <sub>tot</sub> (N)	630	30	-570	0

The mean force during the cycle:

$$F_{rms} = \sqrt{\left( \frac{0,1 \cdot 630^2 + 0,167 \cdot 30^2 + 0,1 \cdot 570^2 + 0,5 \cdot 0}{0,867} \right)} = 289 \text{ N}$$

## Step 4: Motor sizing

Two main criteria for the motor's thrust force should be kept in mind:

1. A linear motor's peak force is depending on the velocity of the coil unit. This can be seen in the linear motor Specification Diagrams.

### Peak force versus velocity (velocity and force in the same direction)

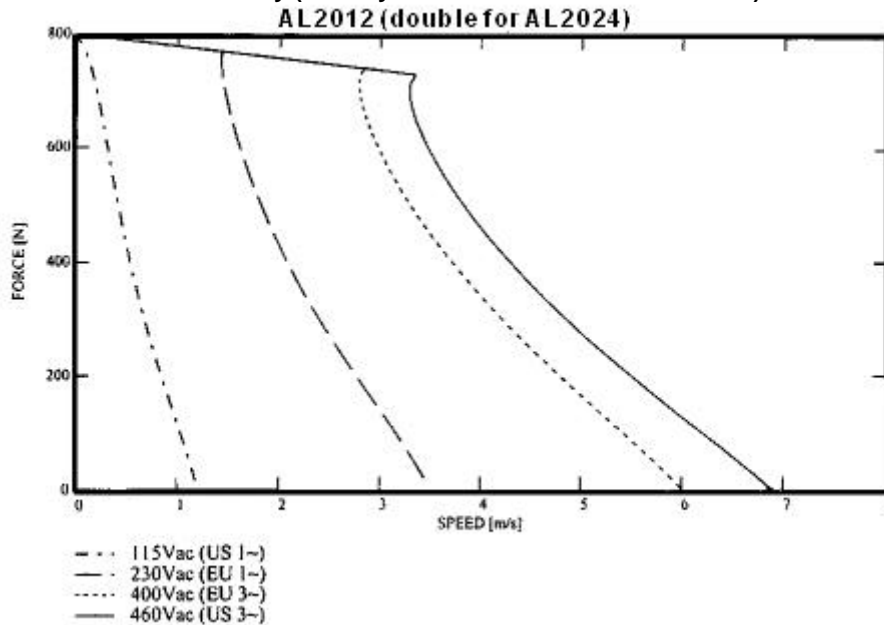

As shown in the diagram this effect depends on the power supply. The speed at  $F=0$  is the limit. For more diagrams see the appendix - 'Peak force - velocity diagrams'.

2.  $F_{rms}$  must remain below the motor's specified continuous force  $F_{cont}$ . The continuous force is a measure for the thermal load of the linear motor. Amongst others it depends on the cooling conditions. For watercooling,  $F_{cont}$  is specified. Without cooling,  $F_{cont}$  is to be estimated. For more information, see the appendix 'Heat transfer and Temperature'.

Choose a linear motor which meets both criteria.

From the calculated mean force and the specified motorconstant the dissipated power is obtained.

$$Q = 1,3 \cdot \frac{F_{rms}^2}{S_{25}} = 103 \cdot \frac{289^2}{740} = 147W$$

This power equals the heat production in the coil unit. It has to be conducted to ambient.

## Step 5: Amplifier sizing

For most servocontrollers the duration of the peakcurrent is limited from 0.25 to several seconds. If the current exceeds the continuous current during a period, longer than this specified time, the required continuous current must be raised to this higher level. So check whether in long periods the required current is over the continuous current. Choose a servocontroller which can deliver the required  $I_{cont}$  and  $I_{peak}$ .

Here, from the specified  $K_{rms}$  and the calculated  $F_{rms}$  we obtain

$$I_{cont} = \frac{289}{93} = 3,1 A$$

The maximum force during the cycle is 630N, so the servo-amplifier has to generate a maximum current

$$I_{peak} = 1,1 \cdot \frac{630}{93} = 7,5 A$$

Since the periods of  $I > I_{cont}$  are no longer than 5 seconds the AX2006 is fulfilling the requirements.

For braking heavy loads from high speeds (for example 100 kg at 4 m/s) the motor feeds back the electrical power into the servo-amplifier. Most of it is dissipated in a braking resistor. Of course this resistor should be of sufficient power, especially when such situations occur frequently (for instance in short repeated moves).

## 4. Appendix

### Heat transfer and temperature

The dissipated power in the coil unit causes a heatflow to the ambient. The resulting temperature rise of the coils is determined by the thermal resistance of the heat conducting route. The coil unit is fitted with a temperature sensor of the PTC 1kOhm type. This sensor detects overtemperature of the coil unit. The servocontroller should check overtemperature at a level of 1000 Ohms

The water-cooling unit can be connected serial as well as parallel. Parallel connection demands a good flow through the T-connection pieces. The watercooling lines are linked to the coil unit by means of standard M5 connections. Haake or Julabo cooling system are compliant with Beckhoff Industrie Elektronik linear motors. Please contact Beckhoff Industrie Elektronik for more information.

As noticed before the linear motor's continuous force is a measure for the thermal load.  $F_{cont}$  depends on the motor constant  $S_{TW}$  and is limited by the allowed working temperature. For watercooling,  $F_{cont}$  is specified. In that case the thermal resistance of both motor and water can be determined. The heat flow results in a limited rise of the temperature.  $T_{coils}$  can be kept controlled beneath the allowed working temperature.

$$\Delta T = Q \cdot R_{th}$$

#### Heatflow and watercooling

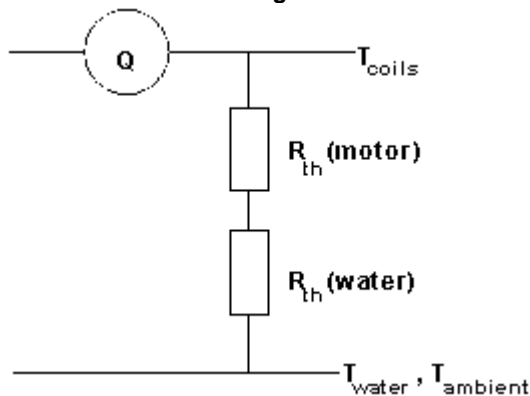

The motor constant depends on the temperature.

$$S_{TW} = \frac{S_{25}}{1 + 0,004(T_W - 25)} \Rightarrow S_{100} = 0,77 \cdot S_{25}$$

This means that the motor's continuous force decreases at high temperatures. When no water cooling is applied, the heat flow usually results in a significant rise of the temperature. The amount depends on the situation. Sometimes it is not so easy to keep  $T_{coils}$  controlled beneath the allowed working temperature.

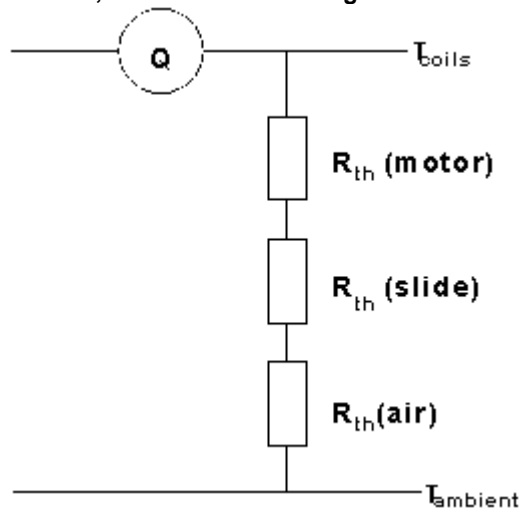
**Heatflow, without water cooling**

Now the heat conducting route and the thermal resistance are much harder to determine. The continuous force has to be estimated. The lower value is specified in the following case:

- A mounting surface about two times the motor dimension.
- Air temperature up to 45°C under a closed hood.
- Stationary or short moves.

The high value can be taken for a large surface (f.i. cooling ribs), forced convection and regulated air temperature below 30°C. For all other situations, estimate a value in between.

## Influences on accuracy

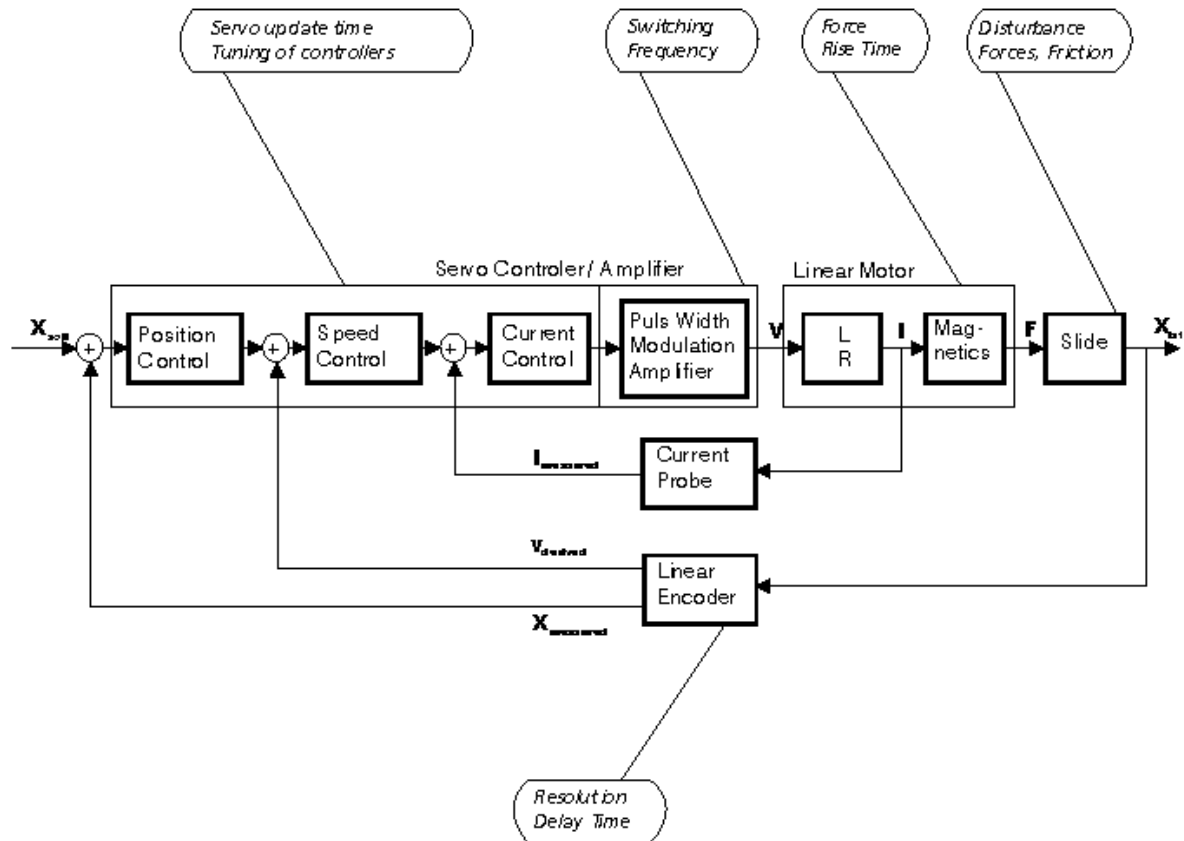

Index:	
	<b>X</b> - position
	<b>v</b> - velocity
	<b>V</b> - voltage
	<b>I</b> - electric current
	<b>F</b> - force
	<b>L</b> - electric self-inductance
	<b>R</b> - electric resistance

## 5. Technical data

### List of specifications AL2000 series

Specifications	Coils/Current	Symbol	Unit	AL2003	AL2006	AL2012	AL2015	AL2024	AL2030
<b>Motortype</b>			3-phase synchronuos						
<b>Peak force 3 minutes<sup>1</sup></b>	magnet@25°C	F <sub>p</sub>	N	200	400	800	1000	1600	2000
<b>Peak current</b>		I <sub>p</sub>	Arms	5	5	10	10	20	20
<b>Continuous Force water-cooled</b>	@100°C	F <sub>cw</sub>	N	105	210	420	525	840	1050
<b>Continuous Force air-cooled<sup>1</sup></b>	@100°C	F <sub>ca</sub>	N	50... 100	100... 200	200... 400	250... 500	400.. 800	500.. 1000
<b>Continuous Power loss</b>	all coils	P <sub>c</sub>	W	80	155	310	370	620	740
<b>Maximum speed<sup>2</sup></b>		V <sub>max</sub>	m/s	6.0	6.0	6.0	6.0	6.0	6.0
<b>Motor force constant</b>	< 0.6I <sub>p</sub>	K	N/Arms	46	93	93	112	93	112
<b>Motor constant</b>	@25°C	S	N <sup>2</sup> /W	185	370	740	970	1480	1940
<b>Magnet Pitch NN</b>		t	mm	24	24	24	24	24	24
<b>Resistance per phase</b>	@25°C	R <sub>f</sub>	Ω	3.9	7.8	3.9	4.3	1.9	2.2
<b>Induction per phase</b>	<0.6I <sub>p</sub>	L <sub>f</sub>	mH	30	60	30	35	15	17.5
<b>Electrical time constant</b>	@25°C	&tau; <sub>e</sub>	ms	8	8	8	8	8	8
<b>Thermal Resistance</b>		R <sub>th</sub>	°C/W	0.96	0.48	0.24	0.20	0.12	0.10
<b>Motor Attraction Force</b>		F <sub>a</sub>	N	500	900	1700	2000	3400	4000
<b>Weight of Coil unit</b>		M <sub>c</sub>	kg	0.9	1.5	2.6	3.2	5.1	6.3
<b>Temperature Sensor</b>	PTC 1 kΩ								

<sup>1</sup> Depends on application: cooling surface, air speed and ambient temperature

<sup>2</sup> Depends on available voltage and required force

## Peak force - velocity diagrams

Velocity diagram AL2003

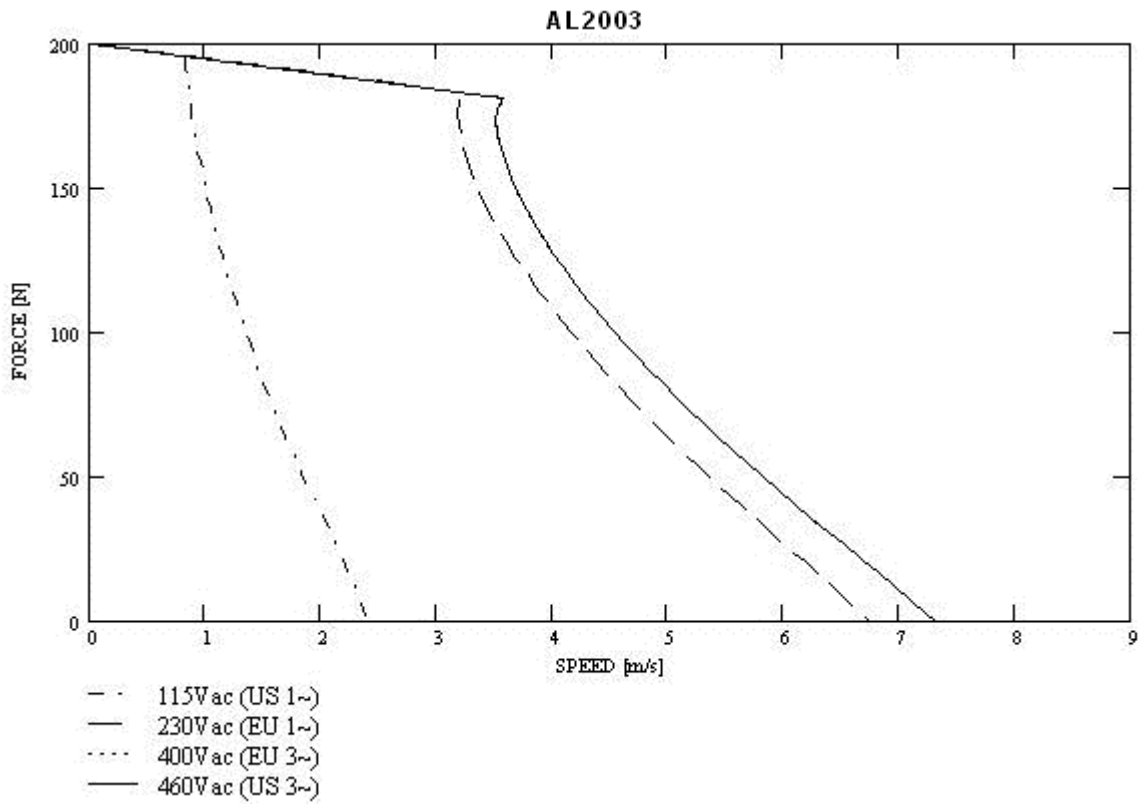

Velocity diagram AL2006

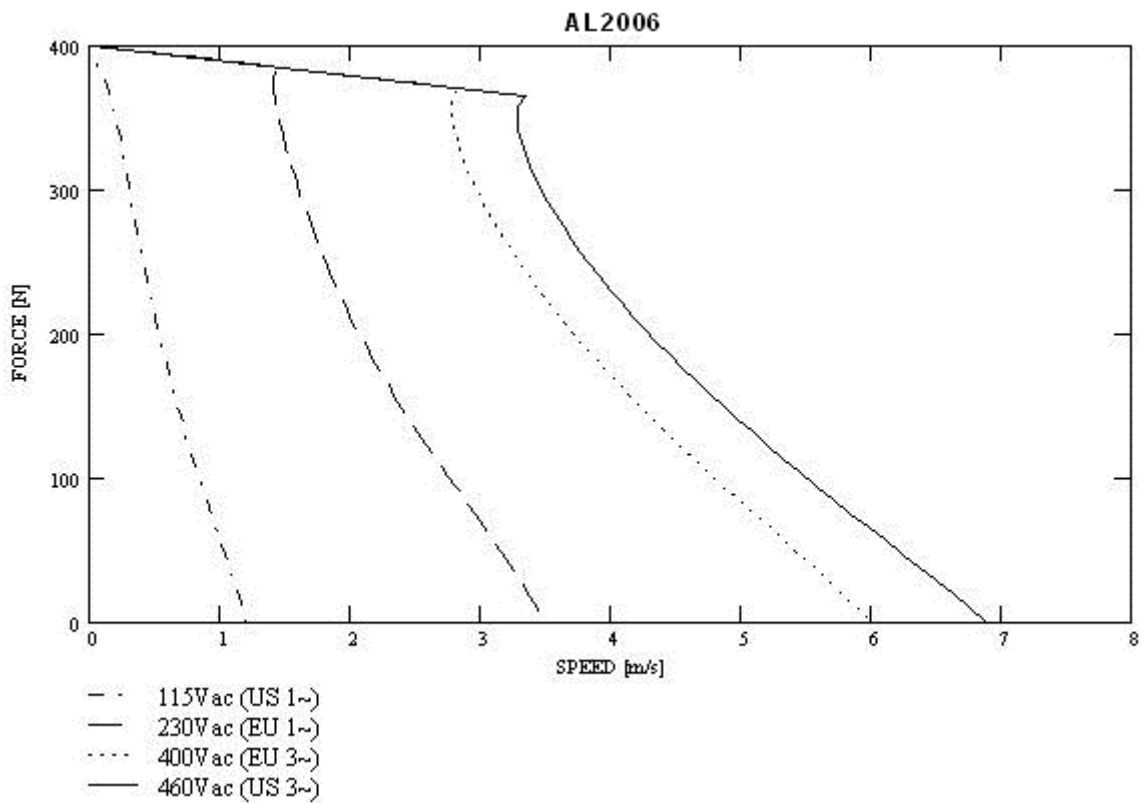

**Velocity diagram AL2012**

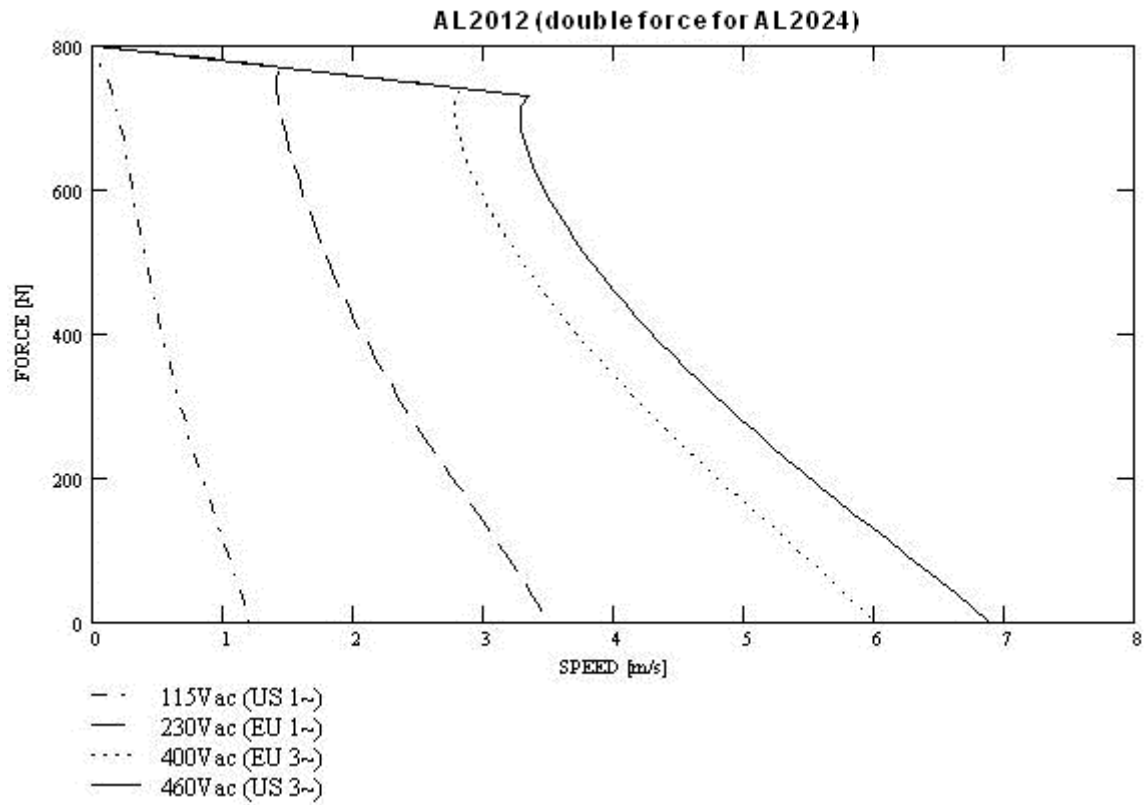

**Velocity diagram AL2015**

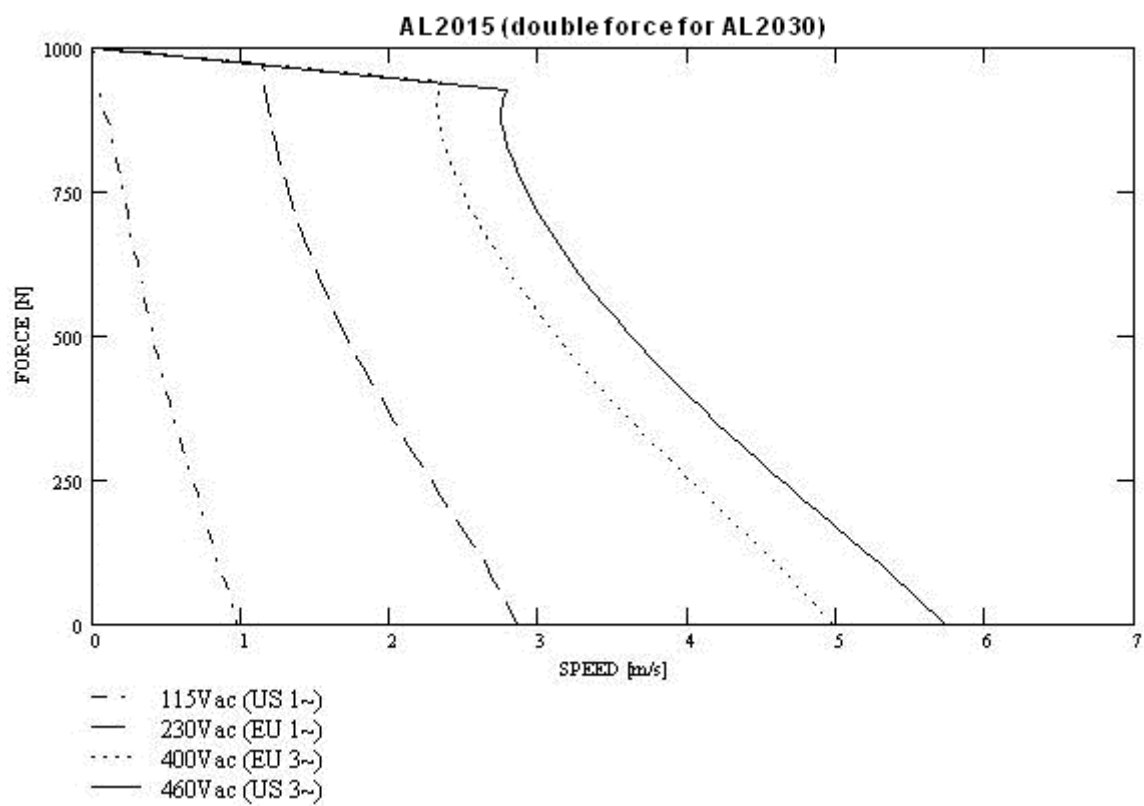

## DC link diagram

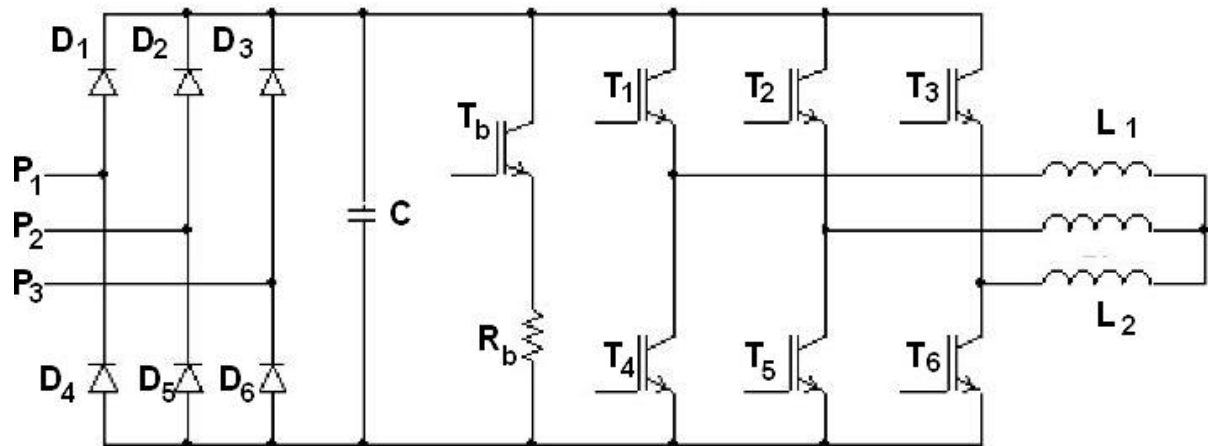

P1, P2 and P3: the three phases of the AC power supply.

- D1 ... D6: these diodes are part of the 3 phase diode bridge.
- C: the DC link capacitor.
- Tb: the activating transistor of the braking resistor.
- Rb: the braking resistor.
- T1 ... T6: transistors of the PWM amplifier stage.
- L1, L2 and L3: The coils of the motor.

## Technical data of some optical linear rulers

Manufacturer type	Encoder period	Stability	Repaetability	Accuracy	Maximum speed	Interface
Heidenhain LIP481	2µm	<2nm	<10nm	± 0.1, 0.2, 0.5 or 1µm/m	5m/s	
Heidenhain LIF181 (C)	4µm	<10nm	<25nm	± 3 or 5µm/m	1m/s	1Vpp
Heidenhain LIDA181 (C)	40µm	<80nm	<200nm	± 5µm/m	8m/s	1Vpp
Heidenhain LIDA185(C)	40µm	<80nm	<200nm	± 3 or 5µm/m	8m/s	1Vpp
Heidenhain LS485	20µm	<40nm	<100nm	± 5µm/m	8 m/s	1Vpp
Heidenhain LS486(C)	20µm	<100nm	<500nm	± 3 or 5µm/m	1 m/s	
Litton/Zeiss LIE5-1PC-FA	20µm	<50nm	<100nm	± 5µm/m	8m/s	
Renishaw RGH-2XR	20µm	<50nm	<100nm	± 3µm/m	4m/s	1Vpp TTL